



FCC TEST REPORT

REPORT NO.: RF950516H01D

MODEL NO.: DWL-2700AP

RECEIVED: June 13, 2008

TESTED: Aug. 01 to Sep. 23, 2008

ISSUED: Sep. 23, 2008

APPLICANT: D-Link Co.

ADDRESS: No.289, Shinhu 3rd Rd., Neihu District, Taipei City
114, Taiwan, R.O.C.

ISSUED BY: Advance Data Technology Corporation

LAB LOCATION: No. 81-1, Lu Liao Keng, 9 Ling, Wu Lung Tsuen,
Chiung Lin Hsiang, Hsin Chu Hsien 307,
Taiwan, R.O.C.

This test report consists of 85 pages in total. It may be duplicated completely for legal use with the approval of the applicant. It should not be reproduced except in full, without the written approval of our laboratory. The client should not use it to claim product endorsement by TAF or any government agencies. The test results in the report only apply to the tested sample.



Table of Contents

1	CERTIFICATION	4
2	SUMMARY OF TEST RESULTS	5
2.1	MEASUREMENT UNCERTAINTY	5
3	GENERAL INFORMATION	6
3.1	GENERAL DESCRIPTION OF EUT	6
3.2	DESCRIPTION OF TEST MODES	9
3.3	TEST MODE APPLICABILITY AND TESTED CHANNEL DETAIL:.....	10
3.4	GENERAL DESCRIPTION OF APPLIED STANDARDS	12
3.5	DESCRIPTION OF SUPPORT UNITS	13
3.6	CONFIGURATION OF SYSTEM UNDER TEST	14
4	TEST TYPES AND RESULTS	16
4.1	CONDUCTED EMISSION MEASUREMENT	16
4.1.1	LIMITS OF CONDUCTED EMISSION MEASUREMENT	16
4.1.2	TEST INSTRUMENTS	16
4.1.3	TEST PROCEDURES	17
4.1.4	TEST SETUP	17
4.1.5	EUT OPERATING CONDITIONS	18
4.1.6	TEST RESULTS	19
4.2	RADIATED EMISSION MEASUREMENT	21
4.2.1	LIMITS OF RADIATED EMISSION MEASUREMENT	21
4.2.2	TEST INSTRUMENTS	22
4.2.3	TEST PROCEDURES	23
4.2.4	TEST SETUP	24
4.2.5	EUT OPERATING CONDITIONS	24
4.2.6	TEST RESULTS – With Antenna 3	25
4.2.7	TEST RESULTS – With Antenna 4	40
4.3	6dB BANDWIDTH MEASUREMENT	55
4.3.1	LIMITS OF 6dB BANDWIDTH MEASUREMENT	55
4.3.2	TEST INSTRUMENTS	55
4.3.3	TEST PROCEDURE	56
4.3.4	TEST SETUP	56
4.3.5	EUT OPERATING CONDITIONS	56
4.3.6	TEST RESULTS	57
4.4	MAXIMUM PEAK OUTPUT POWER	63
4.4.1	LIMITS OF MAXIMUM PEAK OUTPUT POWER MEASUREMENT	63
4.4.2	TEST INSTRUMENTS	63
4.4.3	TEST PROCEDURES	64



4.4.4	TEST SETUP.....	64
4.4.5	EUT OPERATING CONDITIONS	64
4.4.6	TEST RESULTS - With antenna 3.....	65
4.4.7	TEST RESULTS - With antenna 4.....	67
4.5	POWER SPECTRAL DENSITY MEASUREMENT	69
4.5.1	LIMITS OF POWER SPECTRAL DENSITY MEASUREMENT	69
4.5.2	TEST INSTRUMENTS	69
4.5.3	TEST PROCEDURE	70
4.5.4	TEST SETUP.....	70
4.5.5	EUT OPERATING CONDITIONS	70
4.5.6	TEST RESULTS	71
4.6	CONDUCTED OUT-BAND EMISSION MEASUREMENT.....	77
4.6.1	LIMITS OF CONDUCTED OUT-BAND EMISSION MEASUREMENT.....	77
4.6.2	TEST INSTRUMENTS	77
4.6.3	TEST PROCEDURE	77
4.6.4	EUT OPERATING CONDITION.....	77
4.6.5	TEST RESULTS	78
4.7	ANTENNA REQUIREMENT	83
4.7.1	STANDARD APPLICABLE	83
4.7.2	ANTENNA CONNECTED CONSTRUCTION.....	83
5	INFORMATION ON THE TESTING LABORATORIES	84
6	APPENDIX A - MODIFICATIONS RECORDERS FOR ENGINEERING CHANGES TO THE EUT BY THE LAB.....	85



1 CERTIFICATION

PRODUCT : IEEE802.11g Outdoor Access Point
BRAND NAME : D-Link
MODEL NO. : DWL-2700AP
TESTED : Aug. 01 to Sep. 23, 2008
APPLICANT : D-Link Co.
TEST SAMPLE : ENGINEERING SAMPLE
STANDARDS : 47 CFR Part 15, Subpart C (Section 15.247)
ANSI C63.4-2003

The above equipment (Model: DWL-2700AP) has been tested by **Advance Data Technology Corporation**, and found compliance with the requirement of the above standards. The test record, data evaluation & Equipment Under Test (EUT) configurations represented herein are true and accurate accounts of the measurements of the sample's EMC characteristics under the conditions specified in this report.

PREPARED BY : Carol Liao , **DATE:** Sep. 23, 2008
(Carol Liao, Specialist)

TECHNICAL ACCEPTANCE : Hank Chung , **DATE:** Sep. 23, 2008
Responsible for RF (Hank Chung, Deputy Manager)

APPROVED BY : May Chen , **DATE:** Sep. 23, 2008
(May Chen, Deputy Manager)

2 SUMMARY OF TEST RESULTS

The EUT has been tested according to the following specifications:

APPLIED STANDARD: 47 CFR Part 15, Subpart C			
Standard Section	Test Type and Limit	Result	REMARK
15.207	AC Power Conducted Emission	PASS	Meet the requirement of limit Minimum passing margin is -7.92 dB at 0.150 MHz
15.247(a)(2)	Spectrum Bandwidth of a Direct Sequence Spread Spectrum System Limit: min. 500kHz	PASS	Meet the requirement of limit
15.247(b)	Maximum Peak Output Power Limit: max. 30dBm	PASS	Meet the requirement of limit
15.247(d)	Transmitter Radiated Emissions Limit: Table 15.209	PASS	Meet the requirement of limit Minimum passing margin is -0.8 dB at 2387.00 MHz and 2483.50 MHz
15.247(e)	Power Spectral Density Limit: max. 8dBm	PASS	Meet the requirement of limit
15.247(d)	Band Edge Measurement Limit: 20 dB less than the peak value of fundamental frequency	PASS	Meet the requirement of limit

2.1 MEASUREMENT UNCERTAINTY

Where relevant, the following measurement uncertainty levels have been estimated for tests performed on the EUT as specified in CISPR 16-4:

This uncertainty represents an expanded uncertainty expressed at approximately the 95% confidence level using a coverage factor of k=2.

Measurement	Value
Conducted emissions	2.45 dB
Radiated emissions (30MHz-1GHz)	3.94 dB
Radiated emissions (1GHz -18GHz)	2.33 dB
Radiated emissions (18GHz -40GHz)	2.55 dB

3 GENERAL INFORMATION

3.1 GENERAL DESCRIPTION OF EUT

PRODUCT	IEEE802.11g Outdoor Access Point
MODEL NO.	DWL-2700AP
FCC ID	KA2DWL2700APB1
POWER SUPPLY	DC 48V from POE (Power Over Ethernet)
MODULATION TYPE	CCK, DQPSK, DBPSK for DSSS 64QAM, 16QAM, QPSK, BPSK for OFDM
RADIO TECHNOLOGY	DSSS, OFDM
TRANSFER RATE	802.11b: 11/5.5/2/1Mbps 802.11g: 54/48/36/24/18/12/9/6Mbps
FREQUENCY RANGE	2412MHz ~ 2462MHz
NUMBER OF CHANNEL	11
CHANNEL SPACING	5MHz
OUTPUT POWER	802.11b: 239.883mW 802.11g: 354.813mW
ANTENNA TYPE	Please see note 1 (on next page)
DATA CABLE	NA
I/O PORT	RJ45 Port x 1
ASSOCIATED DEVICES	RJ45 cable x 1 (30 m, Shielded)

NOTE:

1. This report is prepared for FCC class II permissive change. The difference compared with the Report No.: RF950516H01 design are as the followings:

- u Adding two antennas.

Original						
No.	Antenna Type	Gain (dBi)	Cable lose(dB)	Arrester lose(dB)	Net Gain (dBi)	Antenna Connector
1	Monopole	5	0.8	0.8	3.4	RP-N Type Male
2	Dipole	4.5	0.8	0.8	2.9	RP-N plug
New						
No.	Antenna Type	Gain (dBi)	Cable lose(dB)	Arrester lose(dB)	Net Gain (dBi)	Antenna Connector
3	Dipole, Omni-Directional	12	7.6523	0.8	3.5477	N female
4	Yagi, directional	21	16.811	0.8	3.389	N female

From above antennas, antenna 3 and 4 were selected as representative antennas for the test.

- u Adding one adapter for model VEG40C-480-AA

Original	
Adapter 1:	
Brand:	LEAD YEAR ENT.
Model No.:	TG-6001-48V
Input power :	AC 100~240Vac/1.6A 50~60Hz
Output power :	DC 48.0V/1.1A
Adapter 2:	
Brand:	LEAD YEAR ENT.
Model No.:	TG-4201-48V-IV
Input power :	AC 100~240V/1.6A 50~60Hz
Output power :	DC 48.0V/0.875A
New	
Adapter 3:	
Brand:	D-Link
Model No.:	VEG40C-480-AA
Input power :	AC 100-240V, 50-60Hz, 0.8A max.
Output power :	DC +48V, 0.88A Power cord: 1.8m/ Non shielded/ With one core

2. The EUT was powered by following POE (Power Over Ethernet):

POE:	
Brand:	D-Link
Model No.:	EBU-101-T2 LF
Input power :	AC 100-240V~0.6A,50~60Hz
Output power :	DC 48V===0.4A

The POE can be powered with above power adapters.

3. The EUT operates in the 2.4GHz frequency spectrum with throughput of up to 54Mbps.
4. The EUT complies with IEEE 802.11g standards, and backwards compatible with IEEE 802.11b products.
5. The above EUT information was declared by the manufacturer and for more detailed features description, please refer to the manufacturer's specifications or User's Manual.

3.2 DESCRIPTION OF TEST MODES

Operated in 2400 ~ 2483.5MHz band:

For 802.11b/g normal mode: Eleven channels are provided to this EUT.

Channel	Frequency	Channel	Frequency
1	2412 MHz	7	2442 MHz
2	2417 MHz	8	2447 MHz
3	2422 MHz	9	2452 MHz
4	2427 MHz	10	2457 MHz
5	2432 MHz	11	2462 MHz
6	2437 MHz		

3.3 TEST MODE APPLICABILITY AND TESTED CHANNEL DETAIL:

EUT configure mode	Applicable to				Description
	PLC	RE<1G	RE≥1G	APCM	
-	√	√	√	√	NA

Where PLC: Power Line Conducted Emission RE<1G: Radiated Emission below 1GHz
 RE≥1G: Radiated Emission above 1GHz APCM: Antenna Port Conducted Measurement

Power Line Conducted Emission Test:

- Pre-Scan has been conducted to determine the worst-case mode from all possible combinations between available modulations, data rates and antenna ports (if EUT with antenna diversity architecture).
- Following channel(s) was (were) selected for the final test as listed below.

Mode	Available Channel	Tested Channel	Modulation Technology	Modulation Type	Data Rate (Mbps)
802.11b	1 to 11	1	DSSS	DBPSK	1

Radiated Emission Test (Below 1 GHz):

- Pre-Scan has been conducted to determine the worst-case mode from all possible combinations between available modulations, data rates and antenna ports (if EUT with antenna diversity architecture).
- Following channel(s) was (were) selected for the final test as listed below.

Mode	Available Channel	Tested Channel	Modulation Technology	Modulation Type	Data Rate (Mbps)
802.11b	1 to 11	1	DSSS	DBPSK	1

- The EUT was tested under the following test modes and its data were recorded in this report:

Test Mode	Description
Mode 1	With antenna 3
Mode 2	With antenna 4

Radiated Emission Test (Above 1 GHz):

- Pre-Scan has been conducted to determine the worst-case mode from all possible combinations between available modulations, data rates and antenna ports (if EUT with antenna diversity architecture).
- Following channel(s) was (were) selected for the final test as listed below.

Mode	Available Channel	Tested Channel	Modulation Technology	Modulation Type	Data Rate (Mbps)
802.11b	1 to 11	1, 6, 11	DSSS	DBPSK	1
802.11g	1 to 11	1, 6, 11	OFDM	BPSK	6

- The EUT was tested under the following test modes and its data were recorded in this report:

Test Mode	Description
Mode 1	With antenna 3
Mode 2	With antenna 4

Bandedge Measurement:

Pre-Scan has been conducted to determine the worst-case mode from all possible combinations between available modulations, data rates and antenna ports (if EUT with antenna diversity architecture).

Following channel(s) was (were) selected for the final test as listed below.

Mode	Available Channel	Tested Channel	Modulation Technology	Modulation Type	Data Rate (Mbps)
802.11b	1 to 11	1, 11	DSSS	DBPSK	1
802.11g	1 to 11	1, 11	OFDM	BPSK	6

The EUT was tested under the following test modes and its data were recorded in this report:

Test Mode	Description
Mode 1	With antenna 3
Mode 2	With antenna 4

Antenna Port Conducted Measurement:

Pre-Scan has been conducted to determine the worst-case mode from all possible combinations between available modulations, data rates and antenna ports (if EUT with antenna diversity architecture).

Following channel(s) was (were) selected for the final test as listed below.

Mode	Available Channel	Tested Channel	Modulation Technology	Modulation Type	Data Rate (Mbps)
802.11b	1 to 11	1, 6, 11	DSSS	DBPSK	1
802.11g	1 to 11	1, 6, 11	OFDM	BPSK	6

3.4 GENERAL DESCRIPTION OF APPLIED STANDARDS

The EUT is an IEEE802.11g Outdoor Access Point. According to the specifications of the manufacturer, it must comply with the requirements of the following standards:

47 CFR Part 15, Subpart C. (15.247)
ANSI C63.4 : 2003

All tests have been performed and recorded as per the above standards.

NOTE: The EUT is also considered as a kind of computer peripheral, because the connection to computer is necessary for typical use. It has been verified to comply with the requirements of 47 CFR Part 15, Subpart B, Class B (DoC). The test report has been issued separately.



3.5 DESCRIPTION OF SUPPORT UNITS

The EUT has been tested as an independent unit together with other necessary accessories or support units. The following support units or accessories were used to form a representative test configuration during the tests.

NO.	PRODUCT	BRAND	MODEL NO.	SERIAL NO.	FCC ID
1	NOTEBOOK COMPUTER	DELL	PP17L	CN-ONF743-48643- 7AV-0124	FCC DoC

NO.	SIGNAL CABLE DESCRIPTION OF THE ABOVE SUPPORT UNITS
1	NA

NOTE: All power cords of the above support units are non-shielded (1.8m).

3.6 CONFIGURATION OF SYSTEM UNDER TEST

For Conducted Emission test:

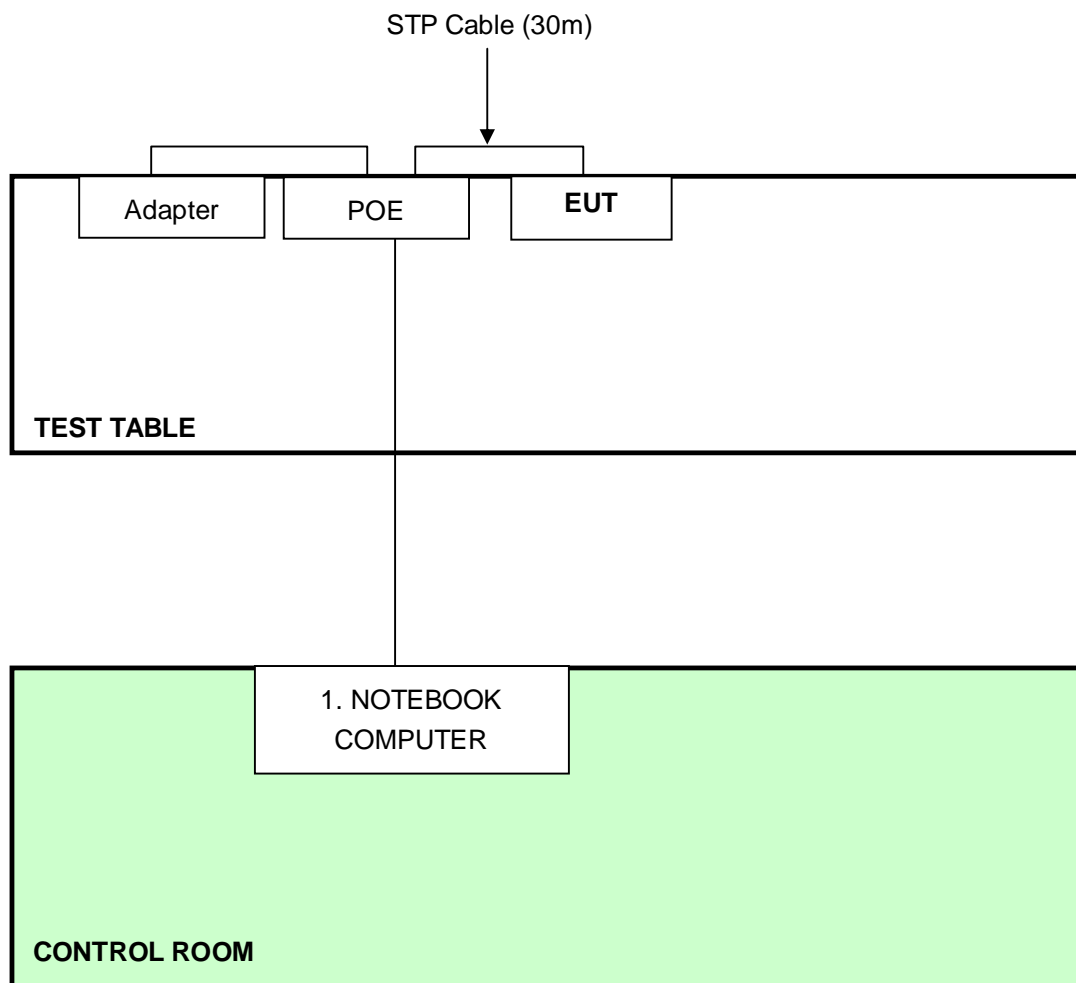

NOTE: 1. Support unit 1 was kept in the control room during the test.

For Radiated Emissions test:

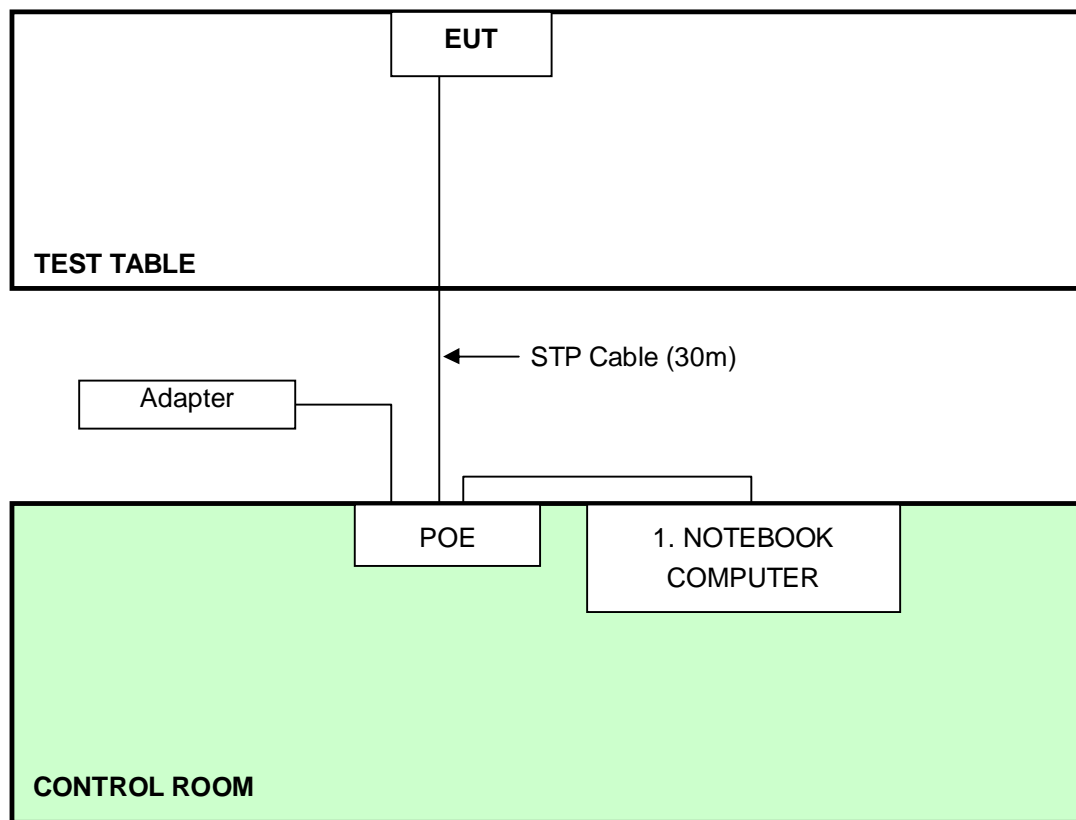

NOTE: 1. Support unit 1 was kept in the control room during the test.

4 TEST TYPES AND RESULTS

4.1 CONDUCTED EMISSION MEASUREMENT

4.1.1 LIMITS OF CONDUCTED EMISSION MEASUREMENT

FREQUENCY OF EMISSION (MHz)	CONDUCTED LIMIT (dB μ V)	
	Quasi-peak	Average
0.15-0.5	66 to 56	56 to 46
0.5-5	56	46
5-30	60	50

NOTE:

1. The lower limit shall apply at the transition frequencies.
2. All emanations from a class B digital device or system, including any network of conductors and apparatus connected thereto, shall not exceed the level of field strengths specified above.

4.1.2 TEST INSTRUMENTS

DESCRIPTION & MANUFACTURER	MODEL NO.	SERIAL NO.	CALIBRATED UNTIL
ROHDE & SCHWARZ Test Receiver	ESCS 30	100287	Mar. 10, 2009
Line-Impedance Stabilization Network(for EUT)	KNW-407	8-1395-12	May. 06, 2009
Line-Impedance Stabilization Network(for Peripheral)	ENV-216	100072	Jun. 12, 2009
RF Cable (JYEBAO)	5DFB	COACAB-001	Jul. 23, 2009
50 ohms Terminator	50	3	Nov. 15, 2008
Software	ADT_Cond_V7.3.2	NA	NA

- NOTE: 1. The calibration interval of the above test instruments is 12 months and the calibrations are traceable to NML/ROC and NIST/USA.
 2. The test was performed in ADT Shielded Room No. A.
 3. The VCCI Con A Registration No. is C-817.

4.1.3 TEST PROCEDURES

- a. The EUT/HOST was placed 0.4 meters from the conducting wall of the shielded room with EUT/HOST being connected to the power mains through a line impedance stabilization network (LISN). Other support units were connected to the power mains through another LISN. The two LISNs provide 50 ohm/ 50uH of coupling impedance for the measuring instrument.
- b. Both lines of the power mains connected to the EUT/HOST were checked for maximum conducted interference.
- c. The frequency range from 150 kHz to 30 MHz was searched. Emission levels over 10dB under the prescribed limits could not be reported

4.1.4 TEST SETUP

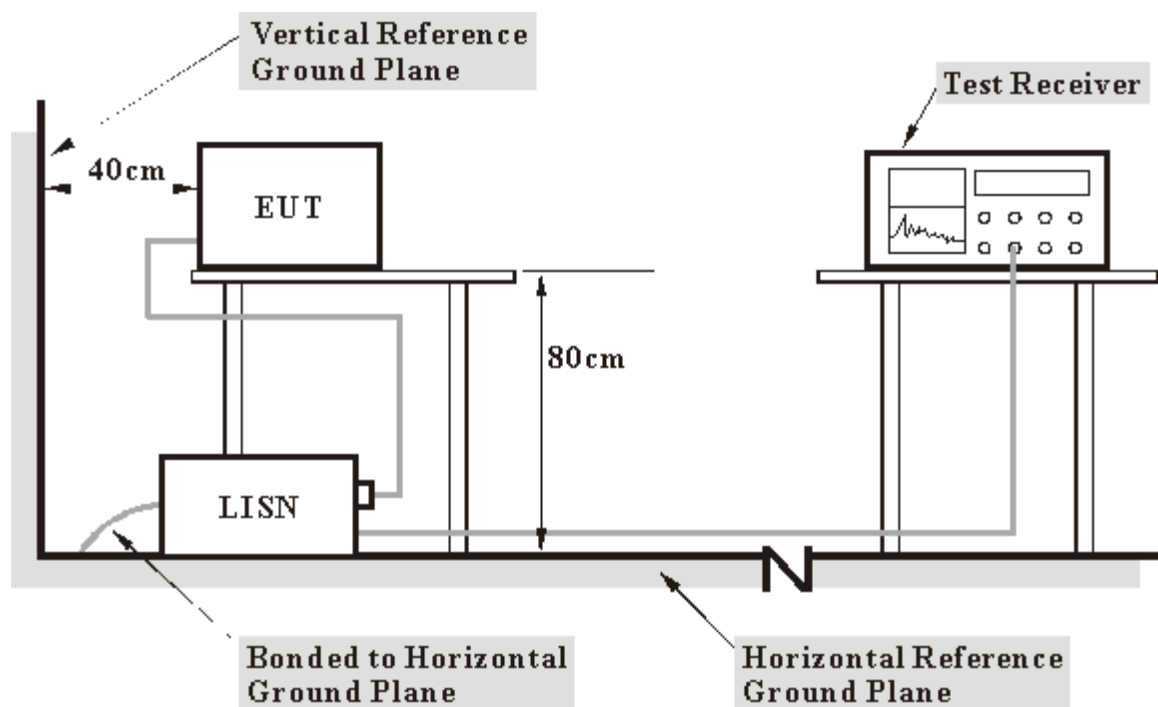

- Note:**
1. Support units were connected to second LISN.
 2. Both of LISNs (AMN) 80 cm from EUT and at the least 80 cm from other units and other metal planes support units.

For the actual test configuration, please refer to the related item – Photographs of the Test Configuration.

4.1.5 EUT OPERATING CONDITIONS

- a. Placed the EUT on the testing table.
- b. Prepared another computer system to act as a communication partner and placed it outside of testing area.
- c. The communication partner run “Art52 Build 58” test program to enable EUT under transmission/receiving condition continuously at specific channel frequency via STP cable.

4.1.6 TEST RESULTS

INPUT POWER	120Vac, 60 Hz	6dB BANDWIDTH	9 kHz
PHASE	Line (L)	TRANSFER RATE	1Mbps
ENVIRONMENTAL CONDITIONS	28deg. C, 60%RH, 965hPa	TESTED BY	Hart Chang

No	Freq. [MHz]	Corr. Factor (dB)	Reading Value		Emission Level		Limit		Margin	
			[dB (uV)]		[dB (uV)]		[dB (uV)]		(dB)	
			Q.P.	AV.	Q.P.	AV.	Q.P.	AV.	Q.P.	AV.
1	0.150	0.61	57.47	45.94	58.08	46.55	66.00	56.00	-7.92	-9.45
2	0.224	0.49	47.75	-	48.24	-	62.66	52.66	-14.42	-
3	0.302	0.45	40.34	-	40.79	-	60.18	50.18	-19.39	-
4	0.369	0.42	34.66	-	35.08	-	58.53	48.53	-23.45	-
5	9.430	0.62	37.39	-	38.01	-	60.00	50.00	-21.99	-
6	28.953	1.08	39.77	-	40.85	-	60.00	50.00	-19.15	-

- REMARKS:**
1. Q.P. and AV. are abbreviations of quasi-peak and average individually.
 2. "-": The Quasi-peak reading value also meets average limit and measurement with the average detector is unnecessary.
 3. The emission levels of other frequencies were very low against the limit.
 4. Margin value = Emission level - Limit value
 5. Correction factor = Insertion loss + Cable loss
 6. Emission Level = Correction Factor + Reading Value.

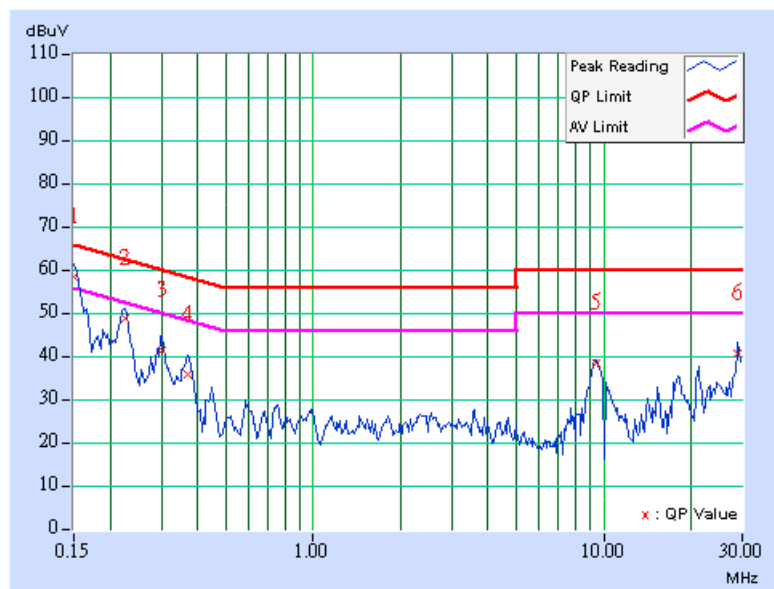

INPUT POWER	120Vac, 60 Hz	6dB BANDWIDTH	9 kHz
PHASE	Neutral (N)	TRANSFER RATE	1Mbps
ENVIRONMENTAL CONDITIONS	28deg. C, 60%RH, 965hPa	TESTED BY	Hart Chang

No	Freq. [MHz]	Corr. Factor (dB)	Reading Value		Emission Level		Limit		Margin	
			[dB (uV)]		[dB (uV)]		[dB (uV)]		(dB)	
			Q.P.	AV.	Q.P.	AV.	Q.P.	AV.	Q.P.	AV.
1	0.150	0.36	57.30	46.29	57.66	46.65	66.00	56.00	-8.34	-9.35
2	0.224	0.24	47.39	-	47.63	-	62.66	52.66	-15.03	-
3	0.302	0.21	40.77	-	40.98	-	60.18	50.18	-19.20	-
4	0.373	0.18	36.14	-	36.32	-	58.44	48.44	-22.12	-
5	9.300	0.41	37.51	-	37.92	-	60.00	50.00	-22.08	-
6	29.148	0.88	43.91	-	44.79	-	60.00	50.00	-15.21	-

- REMARKS:**
1. Q.P. and AV. are abbreviations of quasi-peak and average individually.
 2. "-": The Quasi-peak reading value also meets average limit and measurement with the average detector is unnecessary.
 3. The emission levels of other frequencies were very low against the limit.
 4. Margin value = Emission level - Limit value
 5. Correction factor = Insertion loss + Cable loss
 6. Emission Level = Correction Factor + Reading Value.

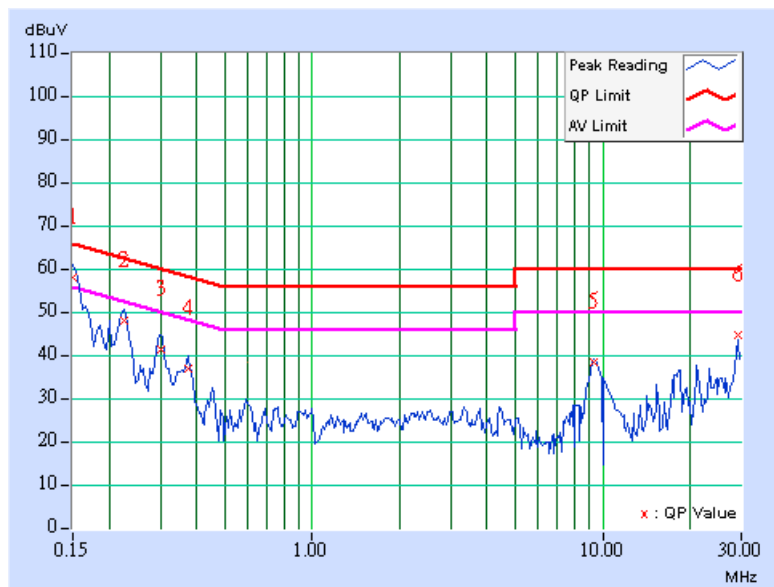

4.2 RADIATED EMISSION MEASUREMENT

4.2.1 LIMITS OF RADIATED EMISSION MEASUREMENT

Emissions radiated outside of the specified bands, shall be according to the general radiated limits in 15.209 as following:

Frequencies (MHz)	Field strength (microvolts/meter)	Measurement distance (meters)
0.009-0.490	2400/F(kHz)	300
0.490-1.705	24000/F(kHz)	30
1.705-30.0	30	30
30-88	100	3
88-216	150	3
216-960	200	3
Above 960	500	3

NOTE:

1. The lower limit shall apply at the transition frequencies.
2. Emission level (dBuV/m) = 20 log Emission level (uV/m).
3. As shown in 15.35(b), for frequencies above 1000MHz, the field strength limits are based on average detector, however, the peak field strength of any emission shall not exceed the maximum permitted average limits, specified above by more than 20dB under any condition of modulation.



4.2.2 TEST INSTRUMENTS

DESCRIPTION & MANUFACTURER	MODEL NO.	SERIAL NO.	CALIBRATED UNTIL
ADVANTEST Spectrum Analyzer	R3271A	85060311	July 15, 2009
HP Pre_Amplifier	8449B	3008A01922	Oct. 04, 2008
ROHDE & SCHWARZ Test Receiver	ESCS30	100375	Mar. 31, 2009
SCHWARZBECK TRILOG Broadband Antenna	VULB 9168	138	April 29, 2009
Schwarzbeck Horn_Antenna	BBHA9120	D124	Dec. 16, 2008
Schwarzbeck Horn_Antenna	BBHA 9170	BBHA9170153	Jan. 27, 2009
RF Switches (ARNITSU)	CS-201	1565157	Aug. 13, 2009
RF CABLE (Chaintek)	SF102	22054-2	Dec. 06. 2008
RF Cable	8DFB	STCCAB-30M-1 GHz	Oct. 09, 2008
Software	ADT_Radiated_V 7.6.15.8	NA	NA
CHANCE MOST Antenna Tower	AT-100	0203	NA
CHANCE MOST Turn Table	TT-100	0203	NA

- Note: 1. The calibration interval of the above test instruments is 12 months and the calibrations are traceable to NML/ROC and NIST/USA.
 2. The horn antenna, HP preamplifier (model: 8449B) and Spectrum Analyzer (model: R3271A) are used only for the measurement of emission frequency above 1GHz if tested.
 3. The test was performed in ADT Open Site No. C.
 4. The FCC Site Registration No. is 656396.
 5. The VCCI Site Registration No. is R-1626.
 6. The CANADA Site Registration No. is IC 3789C-3.

4.2.3 TEST PROCEDURES

- a. The EUT was placed on the top of a rotating table 0.8 meters above the ground at a 10 meter open area test site. The table was rotated 360 degrees to determine the position of the highest radiation.
- b. The EUT was set 3 meters away from the interference-receiving antenna, which was mounted on the top of a variable-height antenna tower.
- c. The antenna is a broadband antenna, and its height is varied from one meter to four meters above the ground to determine the maximum value of the field strength. Both horizontal and vertical polarizations of the antenna are set to make the measurement.
- d. For each suspected emission, the EUT was arranged to its worst case and then the antenna was tuned to heights from 1 meter to 4 meters and the rotatable table was turned from 0 degrees to 360 degrees to find the maximum reading.
- e. The test-receiver system was set to Peak Detect Function and Specified Bandwidth with Maximum Hold Mode.
- f. If the emission level of the EUT in peak mode was 10 dB lower than the limit specified, then testing could be stopped and the peak values of the EUT would be reported. Otherwise the emissions that did not have 10 dB margin would be re-tested one by one using peak, quasi-peak or average method as specified and then reported in a data sheet.

NOTE:

1. The resolution bandwidth and video bandwidth of test receiver/spectrum analyzer is 120kHz for Quasi-peak detection at frequency below 1GHz.
2. The resolution bandwidth is 1MHz and video bandwidth of test receiver/spectrum analyzer is 3MHz for Peak detection at frequency above 1GHz.
3. The resolution bandwidth of test receiver/spectrum analyzer is 1 MHz and the video bandwidth is 10 Hz for Average detection (AV) at frequency above 1GHz.

4.2.4 TEST SETUP

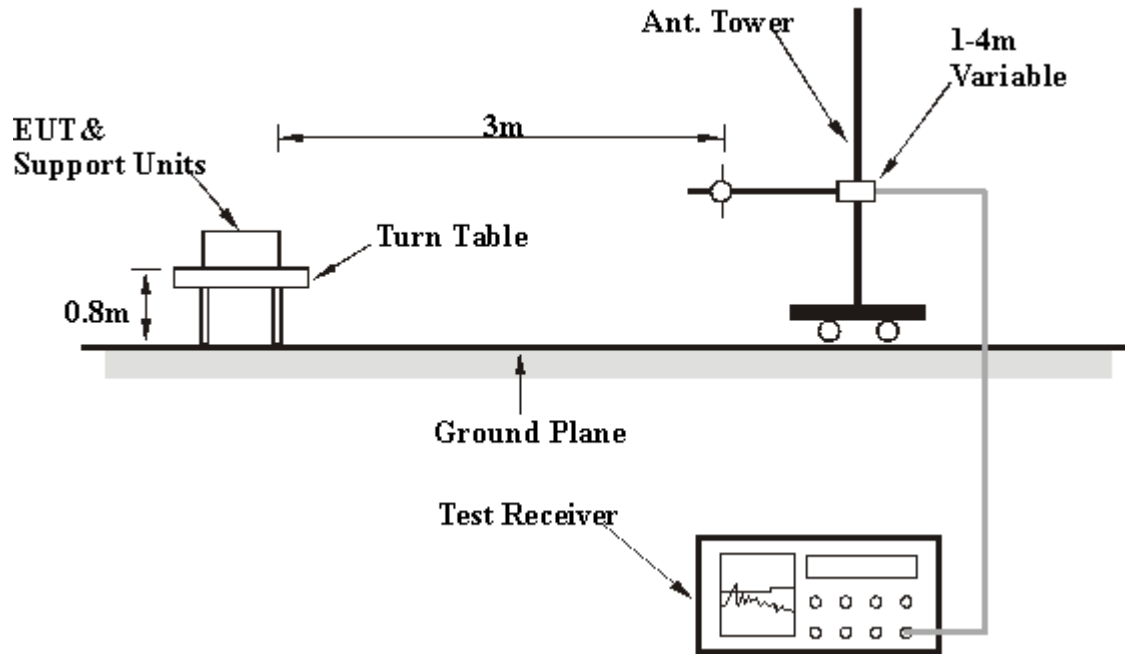

For the actual test configuration, please refer to the related item – Photographs of the Test Configuration.

4.2.5 EUT OPERATING CONDITIONS

Same as 4.1.5

4.2.6 TEST RESULTS – With Antenna 3

EUT TEST CONDITION		MEASUREMENT DETAIL	
CHANNEL	Channel 1	FREQUENCY RANGE	Below 1000MHz
INPUT POWER (SYSTEM)	120Vac, 60 Hz	DETECTOR FUNCTION	Quasi-Peak
ENVIRONMENTAL CONDITIONS	28deg. C, 60%RH 965hPa	TESTED BY	Frank Liu

ANTENNA POLARITY & TEST DISTANCE: HORIZONTAL AT 3 M								
NO.	FREQ. (MHz)	EMISSION LEVEL (dBuV/m)	LIMIT (dBuV/m)	MARGIN (dB)	ANTENNA HEIGHT (m)	TABLE ANGLE (Degree)	RAW VALUE (dBuV)	CORRECTION FACTOR (dB/m)
1	76.71	23.84 QP	40.00	-16.16	1.50 H	279	12.29	11.55
2	159.33	26.88 QP	43.50	-16.62	2.70 H	144	11.48	15.40
3	181.30	28.02 QP	43.50	-15.48	1.50 H	70	14.34	13.68
4	400.00	25.36 QP	46.00	-20.64	1.00 H	32	5.23	20.13
5	663.00	30.54 QP	46.00	-15.46	1.20 H	80	5.72	24.82
6	800.01	39.42 QP	46.00	-6.58	1.00 H	200	10.97	28.45
7	998.99	34.22 QP	54.00	-19.78	1.02 H	41	2.95	31.27
ANTENNA POLARITY & TEST DISTANCE: VERTICAL AT 3 M								
NO.	FREQ. (MHz)	EMISSION LEVEL (dBuV/m)	LIMIT (dBuV/m)	MARGIN (dB)	ANTENNA HEIGHT (m)	TABLE ANGLE (Degree)	RAW VALUE (dBuV)	CORRECTION FACTOR (dB/m)
1	45.22	37.25 QP	40.00	-2.75	1.00 V	314	24.19	13.06
2	160.02	33.49 QP	43.50	-10.01	1.05 V	77	18.10	15.39
3	250.00	31.86 QP	46.00	-14.14	1.05 V	198	17.36	14.50
4	500.00	26.34 QP	46.00	-19.66	1.09 V	20	5.03	21.31
5	627.22	31.08 QP	46.00	-14.92	1.20 V	81	7.11	23.97
6	800.01	33.43 QP	46.00	-12.57	1.40 V	28	4.98	28.45

- REMARKS:**
1. Emission level (dBuV/m) = Raw Value (dBuV) + Correction Factor (dB/m).
 2. Correction Factor (dB/m) = Antenna Factor (dB/m) + Cable Factor (dB).
 3. The other emission levels were very low against the limit.
 4. Margin value = Emission level – Limit value.

802.11b DSSS MODULATION

EUT TEST CONDITION		MEASUREMENT DETAIL	
CHANNEL	Channel 1	FREQUENCY RANGE	1 ~ 25GHz
INPUT POWER (SYSTEM)	120Vac, 60 Hz	DETECTOR FUNCTION	Peak (PK) Average (AV)
ENVIRONMENTAL CONDITIONS	28deg. C, 65%RH 965hPa	TESTED BY	Wen Yu

ANTENNA POLARITY & TEST DISTANCE: HORIZONTAL AT 3 M								
NO.	FREQ. (MHz)	EMISSION LEVEL (dBuV/m)	LIMIT (dBuV/m)	MARGIN (dB)	ANTENNA HEIGHT (m)	TABLE ANGLE (Degree)	RAW VALUE (dBuV)	CORRECTION FACTOR (dB/m)
1	2390.000	52.80 PK	74.00	-21.20	1.05 H	352	23.03	29.77
2	2390.000	43.20 AV	54.00	-10.80	1.05 H	352	13.43	29.77
3	*2412.000	99.13 PK			1.10 H	200	69.24	29.89
4	*2412.000	93.80 AV			1.10 H	200	63.91	29.89
5	4824.000	44.80 PK	74.00	-29.20	1.22 H	170	9.79	35.01
6	4824.000	36.20 AV	54.00	-17.80	1.22 H	170	1.19	35.01
7	7236.000	51.80 PK	74.00	-22.20	1.12 H	27	10.66	41.14
8	7236.000	38.80 AV	54.00	-15.20	1.12 H	27	-2.34	41.14
ANTENNA POLARITY & TEST DISTANCE: VERTICAL AT 3 M								
NO.	FREQ. (MHz)	EMISSION LEVEL (dBuV/m)	LIMIT (dBuV/m)	MARGIN (dB)	ANTENNA HEIGHT (m)	TABLE ANGLE (Degree)	RAW VALUE (dBuV)	CORRECTION FACTOR (dB/m)
1	2387.000	60.90 PK	74.00	-13.10	1.20 V	300	31.15	29.75
2	2387.000	53.20 AV	54.00	-0.80	1.20 V	300	23.45	29.75
3	2390.000	58.71 PK	74.00	-15.29	1.20 V	300	28.94	29.77
4	2390.000	48.22 AV	54.00	-5.78	1.20 V	300	18.45	29.77
5	*2412.000	112.80 PK			1.08 V	28	82.91	29.89
6	*2412.000	107.90 AV			1.08 V	28	78.01	29.89
7	4824.000	47.22 PK	74.00	-26.78	1.17 V	301	12.21	35.01
8	4824.000	39.83 AV	54.00	-14.17	1.17 V	301	4.82	35.01
9	7236.000	53.81 PK	74.00	-20.19	1.77 V	80	12.67	41.14
10	7236.000	39.44 AV	54.00	-14.56	1.77 V	80	-1.70	41.14

- REMARKS:**
1. Emission level (dBuV/m) = Raw Value (dBuV) + Correction Factor (dB/m).
 2. Correction Factor (dB/m) = Antenna Factor (dB/m) + Cable Factor (dB).
 3. The other emission levels were very low against the limit.
 4. Margin value = Emission level – Limit value.
 5. “ * ”: Fundamental frequency.

EUT TEST CONDITION		MEASUREMENT DETAIL	
CHANNEL	Channel 6	FREQUENCY RANGE	1 ~ 25GHz
INPUT POWER (SYSTEM)	120Vac, 60 Hz	DETECTOR FUNCTION	Peak (PK) Average (AV)
ENVIRONMENTAL CONDITIONS	28deg. C, 65%RH 965hPa	TESTED BY	Wen Yu

ANTENNA POLARITY & TEST DISTANCE: HORIZONTAL AT 3 M								
NO.	FREQ. (MHz)	EMISSION LEVEL (dBuV/m)	LIMIT (dBuV/m)	MARGIN (dB)	ANTENNA HEIGHT (m)	TABLE ANGLE (Degree)	RAW VALUE (dBuV)	CORRECTION FACTOR (dB/m)
1	2360.000	44.22 PK	74.00	-29.78	1.40 H	27	14.61	29.61
2	2360.000	33.18 AV	54.00	-20.82	1.40 H	27	3.57	29.61
3	*2437.000	102.30 PK			1.90 H	287	72.29	30.01
4	*2437.000	97.88 AV			1.90 H	287	67.87	30.01
5	4874.000	47.82 PK	74.00	-26.18	1.50 H	70	12.63	35.19
6	4874.000	37.90 AV	54.00	-16.10	1.50 H	70	2.71	35.19
7	7311.000	51.90 PK	74.00	-22.10	1.40 H	107	10.52	41.38
8	7311.000	39.22 AV	54.00	-14.78	1.40 H	107	-2.16	41.38
ANTENNA POLARITY & TEST DISTANCE: VERTICAL AT 3 M								
NO.	FREQ. (MHz)	EMISSION LEVEL (dBuV/m)	LIMIT (dBuV/m)	MARGIN (dB)	ANTENNA HEIGHT (m)	TABLE ANGLE (Degree)	RAW VALUE (dBuV)	CORRECTION FACTOR (dB/m)
1	2360.000	56.22 PK	74.00	-17.78	1.50 V	70	26.61	29.61
2	2360.000	47.30 AV	54.00	-6.70	1.50 V	70	17.69	29.61
3	*2437.000	115.90 PK			1.70 V	89	85.89	30.01
4	*2437.000	111.80 AV			1.70 V	89	81.79	30.01
5	4874.000	49.34 PK	74.00	-24.66	1.90 V	274	14.15	35.19
6	4874.000	42.50 AV	54.00	-11.50	1.90 V	274	7.31	35.19
7	7311.000	55.62 PK	74.00	-18.38	1.02 V	70	14.24	41.38
8	7311.000	44.83 AV	54.00	-9.17	1.02 V	70	3.45	41.38

- REMARKS:**
1. Emission level (dBuV/m) = Raw Value (dBuV) + Correction Factor (dB/m).
 2. Correction Factor (dB/m) = Antenna Factor (dB/m) + Cable Factor (dB).
 3. The other emission levels were very low against the limit.
 4. Margin value = Emission level – Limit value.
 5. “ * “: Fundamental frequency.

EUT TEST CONDITION		MEASUREMENT DETAIL	
CHANNEL	Channel 11	FREQUENCY RANGE	1 ~ 25GHz
INPUT POWER (SYSTEM)	120Vac, 60 Hz	DETECTOR FUNCTION	Peak (PK) Average (AV)
ENVIRONMENTAL CONDITIONS	28deg. C, 65%RH 965hPa	TESTED BY	Wen Yu

ANTENNA POLARITY & TEST DISTANCE: HORIZONTAL AT 3 M								
NO.	FREQ. (MHz)	EMISSION LEVEL (dBuV/m)	LIMIT (dBuV/m)	MARGIN (dB)	ANTENNA HEIGHT (m)	TABLE ANGLE (Degree)	RAW VALUE (dBuV)	CORRECTION FACTOR (dB/m)
1	*2462.000	97.11 PK			1.18 H	280	66.99	30.12
2	*2462.000	93.42 AV			1.18 H	280	63.30	30.12
3	2483.500	55.36 PK	74.00	-18.64	1.02 H	84	25.15	30.21
4	2483.500	45.68 AV	54.00	-8.32	1.02 H	84	15.47	30.21
5	2488.000	55.11 PK	74.00	-18.89	1.02 H	84	24.88	30.23
6	2488.000	45.83 AV	54.00	-8.17	1.02 H	84	15.60	30.23
7	4924.000	46.39 PK	74.00	-27.61	1.00 H	64	11.03	35.36
8	4924.000	37.51 AV	54.00	-16.49	1.00 H	64	2.15	35.36
9	7386.000	53.19 PK	74.00	-20.81	1.30 H	42	11.58	41.61
10	7386.000	40.38 AV	54.00	-13.62	1.30 H	42	-1.23	41.61
ANTENNA POLARITY & TEST DISTANCE: VERTICAL AT 3 M								
NO.	FREQ. (MHz)	EMISSION LEVEL (dBuV/m)	LIMIT (dBuV/m)	MARGIN (dB)	ANTENNA HEIGHT (m)	TABLE ANGLE (Degree)	RAW VALUE (dBuV)	CORRECTION FACTOR (dB/m)
1	*2462.000	112.69 PK			1.20 V	97	82.57	30.12
2	*2462.000	108.34 AV			1.20 V	97	78.22	30.12
3	2483.500	60.34 PK	74.00	-13.66	1.33 V	80	30.13	30.21
4	2483.500	51.20 AV	54.00	-2.80	1.33 V	80	20.99	30.21
5	2487.000	61.70 PK	74.00	-12.30	1.33 V	80	31.47	30.23
6	2487.000	51.80 AV	54.00	-2.20	1.33 V	80	21.57	30.23
7	4924.000	49.34 PK	74.00	-24.66	1.87 V	224	13.98	35.36
8	4924.000	39.90 AV	54.00	-14.10	1.87 V	224	4.54	35.36
9	7386.000	51.30 PK	74.00	-22.70	1.33 V	281	9.69	41.61
10	7386.000	40.10 AV	54.00	-13.90	1.33 V	281	-1.51	41.61

- REMARKS:**
1. Emission level (dBuV/m) = Raw Value (dBuV) + Correction Factor (dB/m).
 2. Correction Factor (dB/m) = Antenna Factor (dB/m) + Cable Factor (dB).
 3. The other emission levels were very low against the limit.
 4. Margin value = Emission level – Limit value.
 5. “ * “: Fundamental frequency.

RESTRICTED BANDEDGE (802.11b MODE, CH1, VERTICAL)

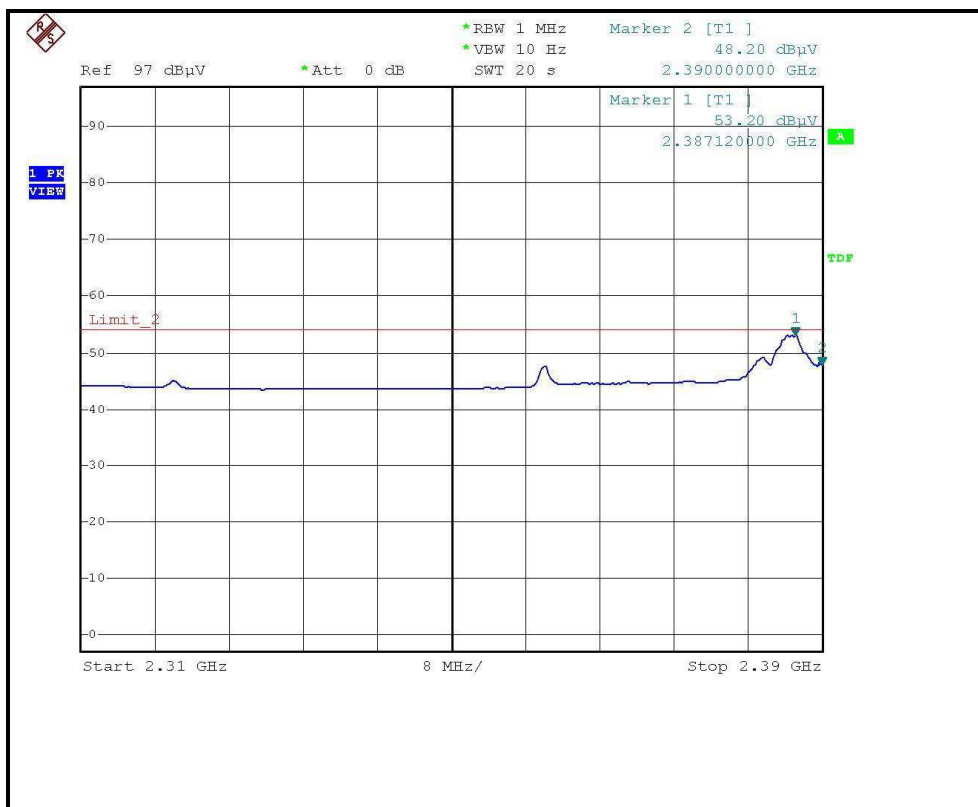
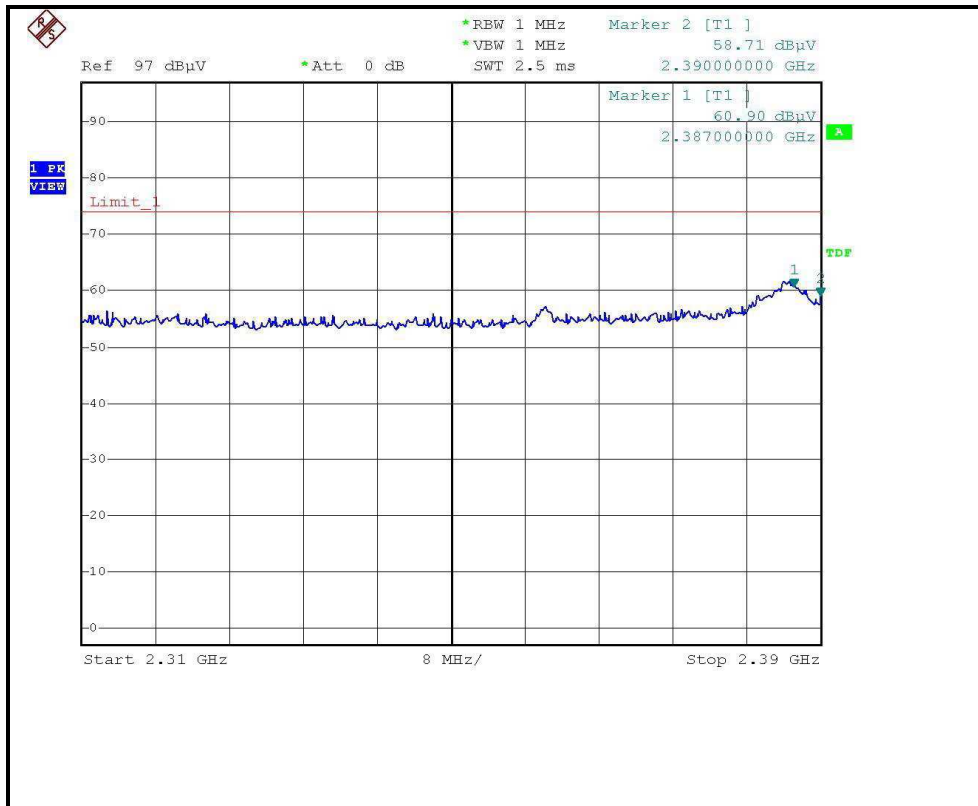

RESTRICTED BANDEDGE (802.11b MODE, CH11, VERTICAL)

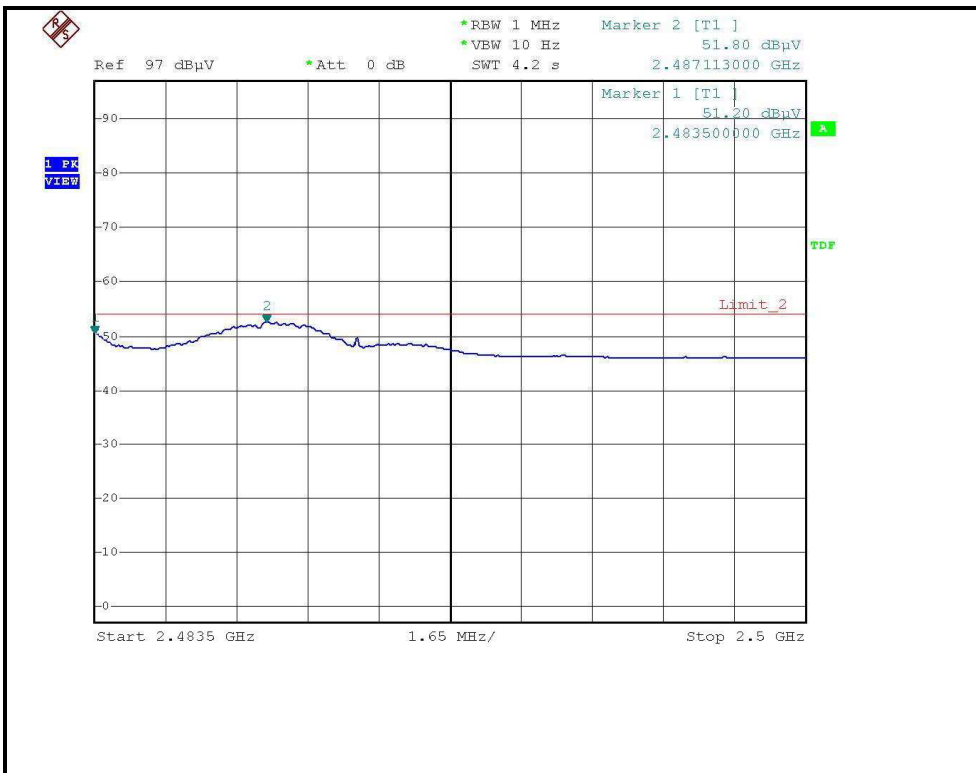
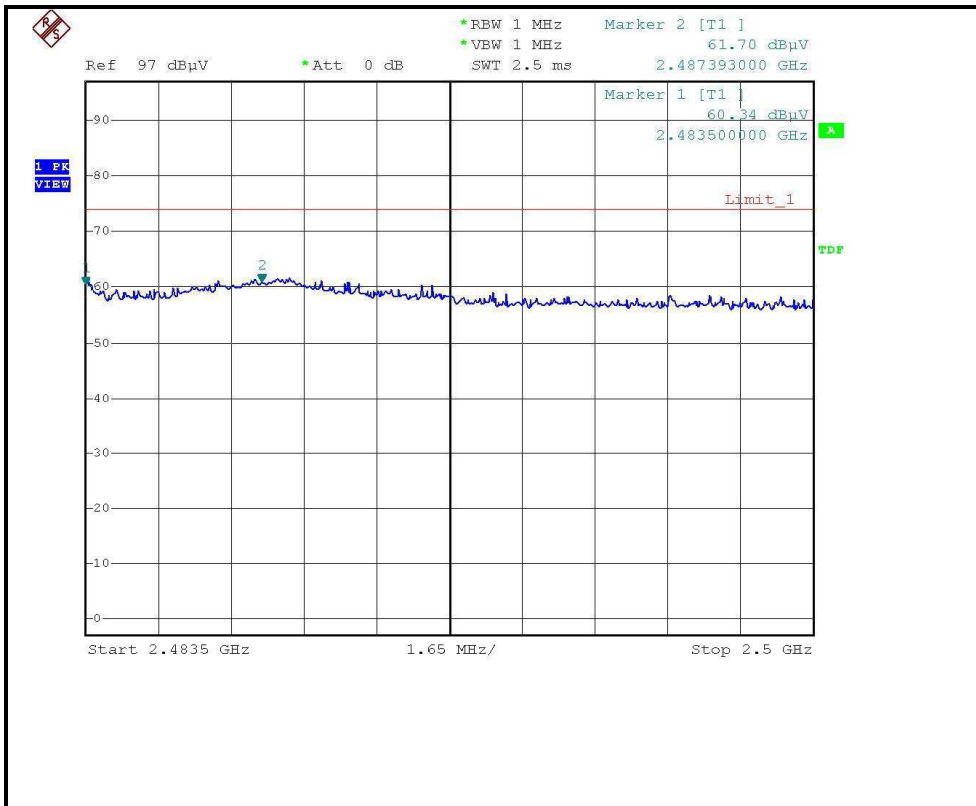

802.11g OFDM MODULATION

EUT TEST CONDITION		MEASUREMENT DETAIL	
CHANNEL	Channel 1	FREQUENCY RANGE	1 ~ 25GHz
INPUT POWER (SYSTEM)	120Vac, 60 Hz	DETECTOR FUNCTION	Peak (PK) Average (AV)
ENVIRONMENTAL CONDITIONS	28deg. C, 65%RH 965hPa	TESTED BY	Wen Yu

ANTENNA POLARITY & TEST DISTANCE: HORIZONTAL AT 3 M								
NO.	FREQ. (MHz)	EMISSION LEVEL (dBuV/m)	LIMIT (dBuV/m)	MARGIN (dB)	ANTENNA HEIGHT (m)	TABLE ANGLE (Degree)	RAW VALUE (dBuV)	CORRECTION FACTOR (dB/m)
1	2390.000	56.34 PK	74.00	-17.66	1.10 H	138	26.57	29.77
2	2390.000	45.70 AV	54.00	-8.30	1.10 H	138	15.93	29.77
3	*2412.000	100.70 PK			1.10 H	81	70.81	29.89
4	*2412.000	89.34 AV			1.10 H	81	59.45	29.89
5	4824.000	46.80 PK	74.00	-27.20	1.50 H	68	11.79	35.01
6	4824.000	32.20 AV	54.00	-21.80	1.50 H	68	-2.81	35.01
7	7236.000	50.20 PK	74.00	-23.80	1.00 H	80	9.06	41.14
8	7236.000	36.70 AV	54.00	-17.30	1.00 H	80	-4.44	41.14
ANTENNA POLARITY & TEST DISTANCE: VERTICAL AT 3 M								
NO.	FREQ. (MHz)	EMISSION LEVEL (dBuV/m)	LIMIT (dBuV/m)	MARGIN (dB)	ANTENNA HEIGHT (m)	TABLE ANGLE (Degree)	RAW VALUE (dBuV)	CORRECTION FACTOR (dB/m)
1	2390.000	68.30 PK	74.00	-5.70	1.09 V	300	38.53	29.77
2	2390.000	52.90 AV	54.00	-1.10	1.09 V	300	23.13	29.77
3	*2412.000	115.80 PK			1.08 V	230	85.91	29.89
4	*2412.000	101.90 AV			1.08 V	230	72.01	29.89
5	4824.000	46.83 PK	74.00	-27.17	1.44 V	44	11.82	35.01
6	4824.000	31.50 AV	54.00	-22.50	1.44 V	44	-3.51	35.01
7	7236.000	51.40 PK	74.00	-22.60	1.38 V	18	10.26	41.14
8	7236.000	40.30 AV	54.00	-13.70	1.38 V	18	-0.84	41.14

- REMARKS:**
1. Emission level (dBuV/m) = Raw Value (dBuV) + Correction Factor (dB/m).
 2. Correction Factor (dB/m) = Antenna Factor (dB/m) + Cable Factor (dB).
 3. The other emission levels were very low against the limit.
 4. Margin value = Emission level – Limit value.
 5. “ * “: Fundamental frequency.

EUT TEST CONDITION		MEASUREMENT DETAIL	
CHANNEL	Channel 6	FREQUENCY RANGE	1 ~ 25GHz
INPUT POWER (SYSTEM)	120Vac, 60 Hz	DETECTOR FUNCTION	Peak (PK) Average (AV)
ENVIRONMENTAL CONDITIONS	28deg. C, 65%RH 965hPa	TESTED BY	Wen Yu

ANTENNA POLARITY & TEST DISTANCE: HORIZONTAL AT 3 M								
NO.	FREQ. (MHz)	EMISSION LEVEL (dBuV/m)	LIMIT (dBuV/m)	MARGIN (dB)	ANTENNA HEIGHT (m)	TABLE ANGLE (Degree)	RAW VALUE (dBuV)	CORRECTION FACTOR (dB/m)
1	2360.000	45.27 PK	74.00	-28.73	1.40 H	29	15.66	29.61
2	2360.000	33.90 AV	54.00	-20.10	1.40 H	29	4.29	29.61
3	*2437.000	105.80 PK			1.10 H	80	75.79	30.01
4	*2437.000	96.70 AV			1.10 H	80	66.69	30.01
5	4874.000	44.90 PK	74.00	-29.10	1.57 H	33	9.71	35.19
6	4874.000	31.10 AV	54.00	-22.90	1.57 H	33	-4.09	35.19
7	7311.000	50.33 PK	74.00	-23.67	1.09 H	211	8.95	41.38
8	7311.000	35.21 AV	54.00	-18.79	1.09 H	211	-6.17	41.38
ANTENNA POLARITY & TEST DISTANCE: VERTICAL AT 3 M								
NO.	FREQ. (MHz)	EMISSION LEVEL (dBuV/m)	LIMIT (dBuV/m)	MARGIN (dB)	ANTENNA HEIGHT (m)	TABLE ANGLE (Degree)	RAW VALUE (dBuV)	CORRECTION FACTOR (dB/m)
1	2360.000	55.42 PK	74.00	-18.58	1.50 V	144	25.81	29.61
2	2360.000	45.10 AV	54.00	-8.90	1.50 V	144	15.49	29.61
3	*2437.000	114.80 PK			1.00 V	278	84.79	30.01
4	*2437.000	105.70 AV			1.00 V	278	75.69	30.01
5	4874.000	46.30 PK	74.00	-27.70	1.30 V	51	11.11	35.19
6	4874.000	32.80 AV	54.00	-21.20	1.30 V	51	-2.39	35.19
7	7311.000	51.80 PK	74.00	-22.20	1.49 V	150	10.42	41.38
8	7311.000	39.40 AV	54.00	-14.60	1.49 V	150	-1.98	41.38

- REMARKS:**
1. Emission level (dBuV/m) = Raw Value (dBuV) + Correction Factor (dB/m).
 2. Correction Factor (dB/m) = Antenna Factor (dB/m) + Cable Factor (dB).
 3. The other emission levels were very low against the limit.
 4. Margin value = Emission level – Limit value.
 5. “ * “: Fundamental frequency.



EUT TEST CONDITION		MEASUREMENT DETAIL	
CHANNEL	Channel 11	FREQUENCY RANGE	1 ~ 25GHz
INPUT POWER (SYSTEM)	120Vac, 60 Hz	DETECTOR FUNCTION	Peak (PK) Average (AV)
ENVIRONMENTAL CONDITIONS	28deg. C, 65%RH 965hPa	TESTED BY	Wen Yu

ANTENNA POLARITY & TEST DISTANCE: HORIZONTAL AT 3 M

NO.	FREQ. (MHz)	EMISSION LEVEL (dBuV/m)	LIMIT (dBuV/m)	MARGIN (dB)	ANTENNA HEIGHT (m)	TABLE ANGLE (Degree)	RAW VALUE (dBuV)	CORRECTION FACTOR (dB/m)
1	*2462.000	97.40 PK			1.07 H	188	67.28	30.12
2	*2462.000	85.20 AV			1.07 H	188	55.08	30.12
3	2483.500	54.90 PK	74.00	-19.10	1.00 H	277	24.69	30.21
4	2483.500	42.70 AV	54.00	-11.30	1.00 H	277	12.49	30.21
5	4924.000	45.30 PK	74.00	-28.70	1.22 H	20	9.94	35.36
6	4924.000	31.80 AV	54.00	-22.20	1.22 H	20	-3.56	35.36
7	7386.000	49.80 PK	74.00	-24.20	1.01 H	114	8.19	41.61
8	7386.000	35.43 AV	54.00	-18.57	1.01 H	114	-6.18	41.61

ANTENNA POLARITY & TEST DISTANCE: VERTICAL AT 3 M

NO.	FREQ. (MHz)	EMISSION LEVEL (dBuV/m)	LIMIT (dBuV/m)	MARGIN (dB)	ANTENNA HEIGHT (m)	TABLE ANGLE (Degree)	RAW VALUE (dBuV)	CORRECTION FACTOR (dB/m)
1	*2462.000	114.80 PK			1.05 V	22	84.68	30.12
2	*2462.000	102.70 AV			1.05 V	22	72.58	30.12
3	2483.500	68.40 PK	74.00	-5.60	1.00 V	30	38.19	30.21
4	2483.500	53.20 AV	54.00	-0.80	1.00 V	30	22.99	30.21
5	4924.000	47.88 PK	74.00	-26.12	1.40 V	251	12.52	35.36
6	4924.000	34.61 AV	54.00	-19.39	1.40 V	251	-0.75	35.36
7	7386.000	52.30 PK	74.00	-21.70	1.40 V	312	10.69	41.61
8	7386.000	40.50 AV	54.00	-13.50	1.40 V	312	-1.11	41.61

- REMARKS:**
1. Emission level (dBuV/m) = Raw Value (dBuV) + Correction Factor (dB/m).
 2. Correction Factor (dB/m) = Antenna Factor (dB/m) + Cable Factor (dB).
 3. The other emission levels were very low against the limit.
 4. Margin value = Emission level – Limit value.
 5. “ * “: Fundamental frequency.

RESTRICTED BANDEDGE (802.11g MODE, CH1, HORIZONTAL)

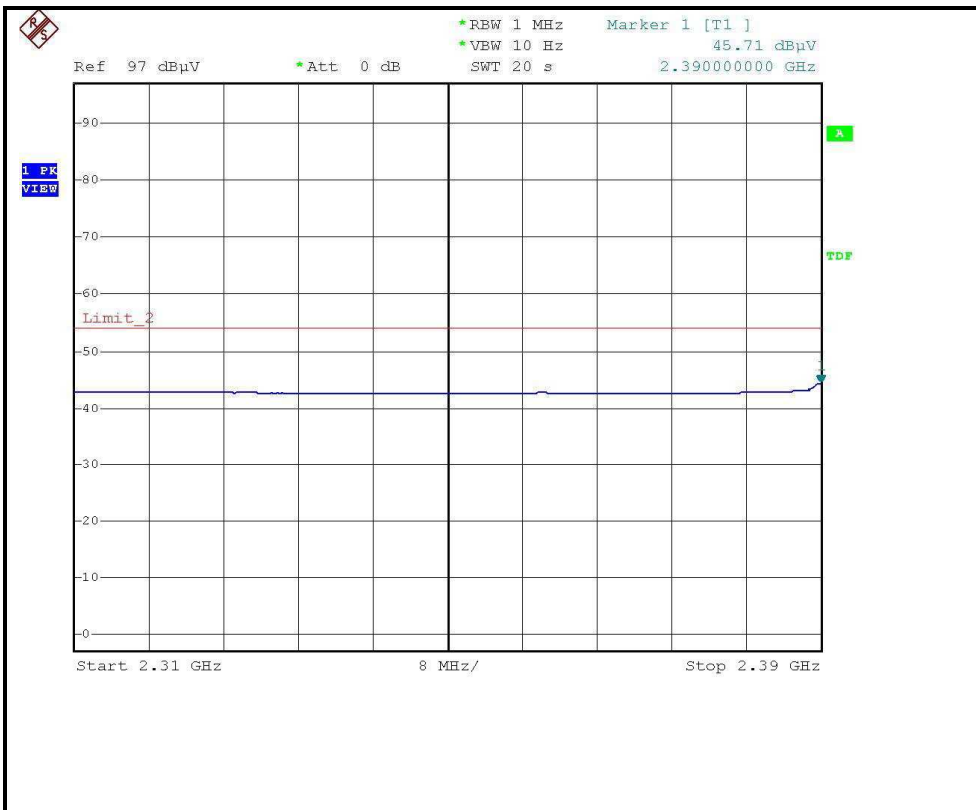
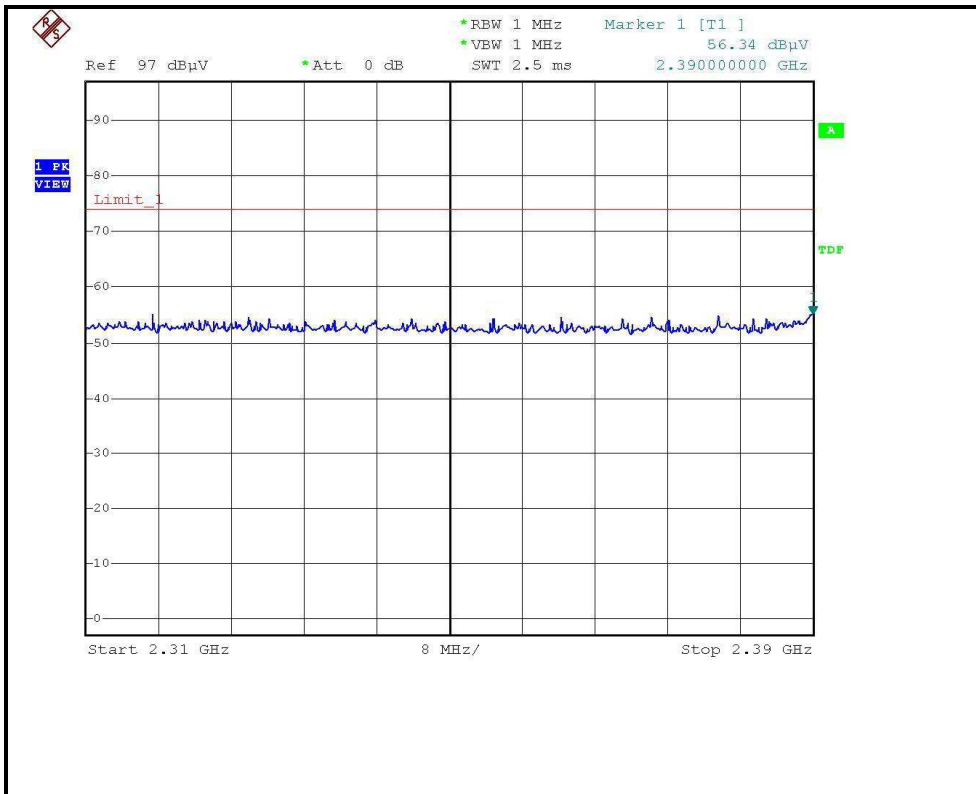

RESTRICTED BANDEDGE (802.11g MODE, CH11, VERTICAL)

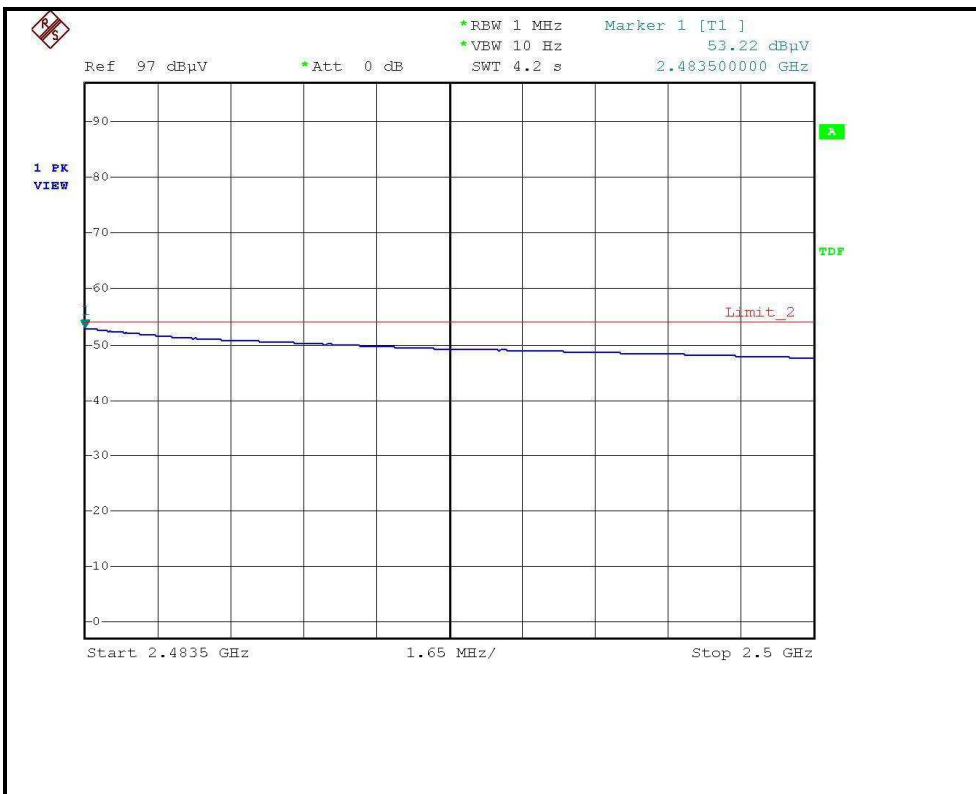
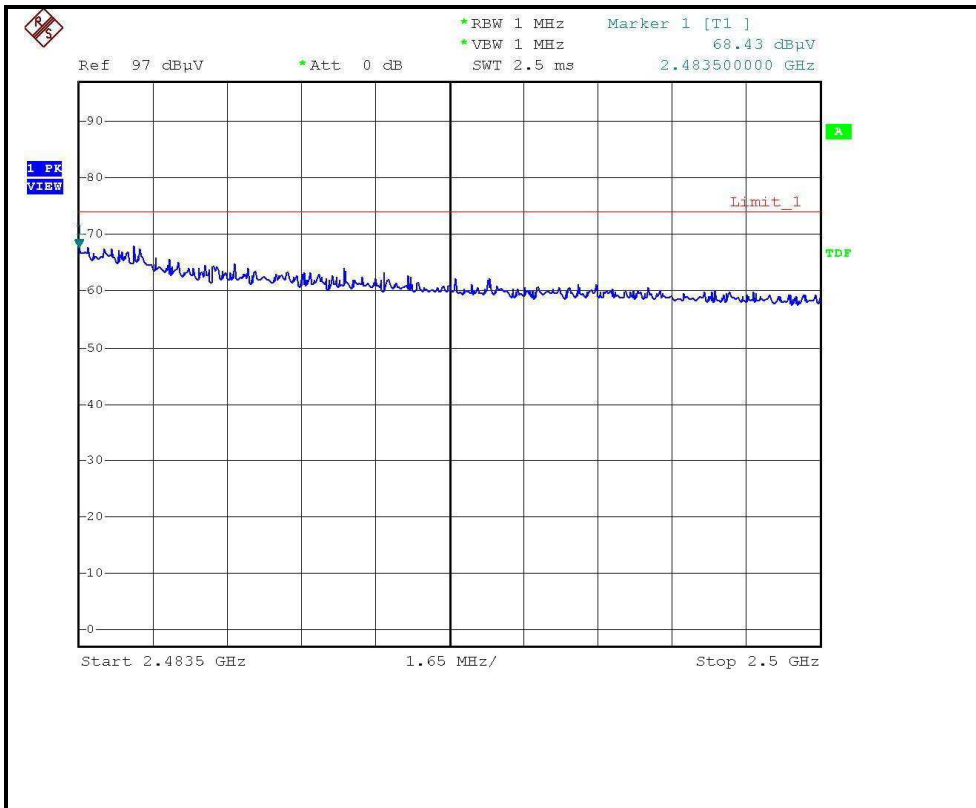

4.2.7 TEST RESULTS – With Antenna 4

EUT TEST CONDITION		MEASUREMENT DETAIL	
CHANNEL	Channel 1	FREQUENCY RANGE	Below 1000MHz
INPUT POWER (SYSTEM)	120Vac, 60 Hz	DETECTOR FUNCTION	Quasi-Peak
ENVIRONMENTAL CONDITIONS	28deg. C, 60%RH 965hPa	TESTED BY	Frank Liu

ANTENNA POLARITY & TEST DISTANCE: HORIZONTAL AT 3 M								
NO.	FREQ. (MHz)	EMISSION LEVEL (dBuV/m)	LIMIT (dBuV/m)	MARGIN (dB)	ANTENNA HEIGHT (m)	TABLE ANGLE (Degree)	RAW VALUE (dBuV)	CORRECTION FACTOR (dB/m)
1	75.69	21.60 QP	40.00	-18.40	1.55 H	115	9.94	11.66
2	113.19	21.08 QP	43.50	-22.42	1.62 H	251	9.05	12.03
3	158.15	25.22 QP	43.50	-18.28	2.20 H	102	9.79	15.43
4	181.72	27.74 QP	43.50	-15.76	1.24 H	247	14.09	13.65
5	250.00	23.42 QP	46.00	-22.58	1.34 H	1	8.92	14.50
6	400.00	24.39 QP	46.00	-21.61	1.00 H	201	4.26	20.13
7	663.00	29.81 QP	46.00	-16.19	1.24 H	92	4.99	24.82
8	799.91	38.74 QP	46.00	-7.26	1.00 H	159	10.29	28.45
9	1000.00	35.31 QP	54.00	-18.69	1.00 H	92	4.02	31.29
ANTENNA POLARITY & TEST DISTANCE: VERTICAL AT 3 M								
NO.	FREQ. (MHz)	EMISSION LEVEL (dBuV/m)	LIMIT (dBuV/m)	MARGIN (dB)	ANTENNA HEIGHT (m)	TABLE ANGLE (Degree)	RAW VALUE (dBuV)	CORRECTION FACTOR (dB/m)
1	43.53	35.84 QP	40.00	-4.16	1.00 V	338	22.95	12.89
2	158.03	32.59 QP	43.50	-10.91	1.00 V	79	17.16	15.43
3	161.85	25.94 QP	43.50	-17.56	1.00 V	271	10.74	15.20
4	250.00	30.97 QP	46.00	-15.03	1.00 V	258	16.47	14.50
5	266.98	30.38 QP	46.00	-15.62	1.08 V	244	15.24	15.14
6	500.00	25.96 QP	46.00	-20.04	1.00 V	288	4.65	21.31
7	627.25	32.04 QP	46.00	-13.96	1.17 V	9	8.07	23.97
8	799.92	33.17 QP	46.00	-12.83	1.38 V	21	4.72	28.45

- REMARKS:**
1. Emission level (dBuV/m) = Raw Value (dBuV) + Correction Factor (dB/m).
 2. Correction Factor (dB/m) = Antenna Factor (dB/m) + Cable Factor (dB).
 3. The other emission levels were very low against the limit.
 4. Margin value = Emission level – Limit value.

802.11b DSSS MODULATION

EUT TEST CONDITION		MEASUREMENT DETAIL	
CHANNEL	Channel 1	FREQUENCY RANGE	1 ~ 25GHz
INPUT POWER (SYSTEM)	120Vac, 60 Hz	DETECTOR FUNCTION	Peak (PK) Average (AV)
ENVIRONMENTAL CONDITIONS	28deg. C, 64%RH 965hPa	TESTED BY	Frank Liu

ANTENNA POLARITY & TEST DISTANCE: HORIZONTAL AT 3 M								
NO.	FREQ. (MHz)	EMISSION LEVEL (dBuV/m)	LIMIT (dBuV/m)	MARGIN (dB)	ANTENNA HEIGHT (m)	TABLE ANGLE (Degree)	RAW VALUE (dBuV)	CORRECTION FACTOR (dB/m)
1	2390.00	53.22 PK	74.00	-20.78	1.54 H	227	23.16	30.06
2	2390.00	43.03 AV	54.00	-10.97	1.54 H	227	12.97	30.06
3	*2412.00	90.30 PK			1.54 H	227	60.15	30.15
4	*2412.00	81.50 AV			1.54 H	227	51.35	30.15
5	4824.00	46.30 PK	74.00	-27.70	1.46 H	246	10.84	35.46
6	4824.00	34.20 AV	54.00	-19.80	1.46 H	246	-1.26	35.46
7	7236.00	51.80 PK	74.00	-22.20	1.46 H	233	9.95	41.85
8	7236.00	37.40 AV	54.00	-16.60	1.46 H	233	-4.45	41.85
ANTENNA POLARITY & TEST DISTANCE: VERTICAL AT 3 M								
NO.	FREQ. (MHz)	EMISSION LEVEL (dBuV/m)	LIMIT (dBuV/m)	MARGIN (dB)	ANTENNA HEIGHT (m)	TABLE ANGLE (Degree)	RAW VALUE (dBuV)	CORRECTION FACTOR (dB/m)
1	2386.40	59.01 PK	74.00	-14.99	1.18 V	9	28.96	30.05
2	2386.40	48.46 AV	54.00	-5.54	1.18 V	9	18.41	30.05
3	*2412.00	108.80 PK			1.17 V	5	78.65	30.15
4	*2412.00	103.10 AV			1.17 V	5	72.95	30.15
5	4824.00	46.60 PK	74.00	-27.40	1.16 V	114	11.14	35.46
6	4824.00	35.90 AV	54.00	-18.10	1.16 V	114	0.44	35.46
7	7236.00	51.90 PK	74.00	-22.10	1.00 V	126	10.05	41.85
8	7236.00	37.60 AV	54.00	-16.40	1.00 V	126	-4.25	41.85

- REMARKS:**
1. Emission level (dBuV/m) = Raw Value (dBuV) + Correction Factor (dB/m).
 2. Correction Factor (dB/m) = Antenna Factor (dB/m) + Cable Factor (dB).
 3. The other emission levels were very low against the limit.
 4. Margin value = Emission level – Limit value.
 5. “ * “: Fundamental frequency.

EUT TEST CONDITION		MEASUREMENT DETAIL	
CHANNEL	Channel 6	FREQUENCY RANGE	1 ~ 25GHz
INPUT POWER (SYSTEM)	120Vac, 60 Hz	DETECTOR FUNCTION	Peak (PK) Average (AV)
ENVIRONMENTAL CONDITIONS	28deg. C, 64%RH 965hPa	TESTED BY	Frank Liu

ANTENNA POLARITY & TEST DISTANCE: HORIZONTAL AT 3 M								
NO.	FREQ. (MHz)	EMISSION LEVEL (dBuV/m)	LIMIT (dBuV/m)	MARGIN (dB)	ANTENNA HEIGHT (m)	TABLE ANGLE (Degree)	RAW VALUE (dBuV)	CORRECTION FACTOR (dB/m)
1	*2437.00	89.00 PK			1.56 H	226	58.76	30.24
2	*2437.00	80.50 AV			1.56 H	226	50.26	30.24
3	4874.00	48.10 PK	74.00	-25.90	1.94 H	28	12.55	35.55
4	4874.00	38.20 AV	54.00	-15.80	1.94 H	28	2.65	35.55
5	7311.00	52.00 PK	74.00	-22.00	1.30 H	294	9.96	42.04
6	7311.00	39.00 AV	54.00	-15.00	1.30 H	294	-3.04	42.04
ANTENNA POLARITY & TEST DISTANCE: VERTICAL AT 3 M								
NO.	FREQ. (MHz)	EMISSION LEVEL (dBuV/m)	LIMIT (dBuV/m)	MARGIN (dB)	ANTENNA HEIGHT (m)	TABLE ANGLE (Degree)	RAW VALUE (dBuV)	CORRECTION FACTOR (dB/m)
1	*2437.00	109.30 PK			1.23 V	169	79.06	30.24
2	*2437.00	104.50 AV			1.23 V	169	74.26	30.24
3	4874.00	50.30 PK	74.00	-23.70	1.20 V	123	14.75	35.55
4	4874.00	44.00 AV	54.00	-10.00	1.20 V	123	8.45	35.55
5	7311.00	53.40 PK	74.00	-20.60	1.03 V	133	11.36	42.04
6	7311.00	40.30 AV	54.00	-13.70	1.03 V	133	-1.74	42.04

- REMARKS:**
1. Emission level (dBuV/m) = Raw Value (dBuV) + Correction Factor (dB/m).
 2. Correction Factor (dB/m) = Antenna Factor (dB/m) + Cable Factor (dB).
 3. The other emission levels were very low against the limit.
 4. Margin value = Emission level – Limit value.
 5. “ * “: Fundamental frequency.



EUT TEST CONDITION		MEASUREMENT DETAIL	
CHANNEL	Channel 11	FREQUENCY RANGE	1 ~ 25GHz
INPUT POWER (SYSTEM)	120Vac, 60 Hz	DETECTOR FUNCTION	Peak (PK) Average (AV)
ENVIRONMENTAL CONDITIONS	28deg. C, 64%RH 965hPa	TESTED BY	Frank Liu

ANTENNA POLARITY & TEST DISTANCE: HORIZONTAL AT 3 M

NO.	FREQ. (MHz)	EMISSION LEVEL (dBuV/m)	LIMIT (dBuV/m)	MARGIN (dB)	ANTENNA HEIGHT (m)	TABLE ANGLE (Degree)	RAW VALUE (dBuV)	CORRECTION FACTOR (dB/m)
1	*2462.00	90.30 PK			1.57 H	230	59.96	30.34
2	*2462.00	81.60 AV			1.57 H	230	51.26	30.34
3	2483.50	53.76 PK	74.00	-20.24	1.53 H	223	23.33	30.43
4	2483.50	43.89 AV	54.00	-10.11	1.53 H	223	13.46	30.43
5	4924.00	47.70 PK	74.00	-26.30	1.45 H	264	12.07	35.63
6	4924.00	40.10 AV	54.00	-13.90	1.45 H	264	4.47	35.63
7	7386.00	51.60 PK	74.00	-22.40	1.34 H	231	9.37	42.23
8	7386.00	38.20 AV	54.00	-15.80	1.34 H	231	-4.03	42.23

ANTENNA POLARITY & TEST DISTANCE: VERTICAL AT 3 M

NO.	FREQ. (MHz)	EMISSION LEVEL (dBuV/m)	LIMIT (dBuV/m)	MARGIN (dB)	ANTENNA HEIGHT (m)	TABLE ANGLE (Degree)	RAW VALUE (dBuV)	CORRECTION FACTOR (dB/m)
1	*2462.00	107.90 PK			1.24 V	1	77.56	30.34
2	*2462.00	104.30 AV			1.24 V	1	73.96	30.34
3	2487.40	58.61 PK	74.00	-15.39	1.05 V	359	28.17	30.44
4	2487.40	48.88 AV	54.00	-5.12	1.05 V	359	18.44	30.44
5	4924.00	47.20 PK	74.00	-26.80	1.16 V	120	11.57	35.63
6	4924.00	36.70 AV	54.00	-17.30	1.16 V	120	1.07	35.63
7	7386.00	54.20 PK	74.00	-19.80	1.00 V	126	11.97	42.23
8	7386.00	42.30 AV	54.00	-11.70	1.00 V	126	0.07	42.23

- REMARKS:**
1. Emission level (dBuV/m) = Raw Value (dBuV) + Correction Factor (dB/m).
 2. Correction Factor (dB/m) = Antenna Factor (dB/m) + Cable Factor (dB).
 3. The other emission levels were very low against the limit.
 4. Margin value = Emission level – Limit value.
 5. “ * “: Fundamental frequency.

RESTRICTED BANDEDGE (802.11b MODE, CH1, HORIZONTAL)

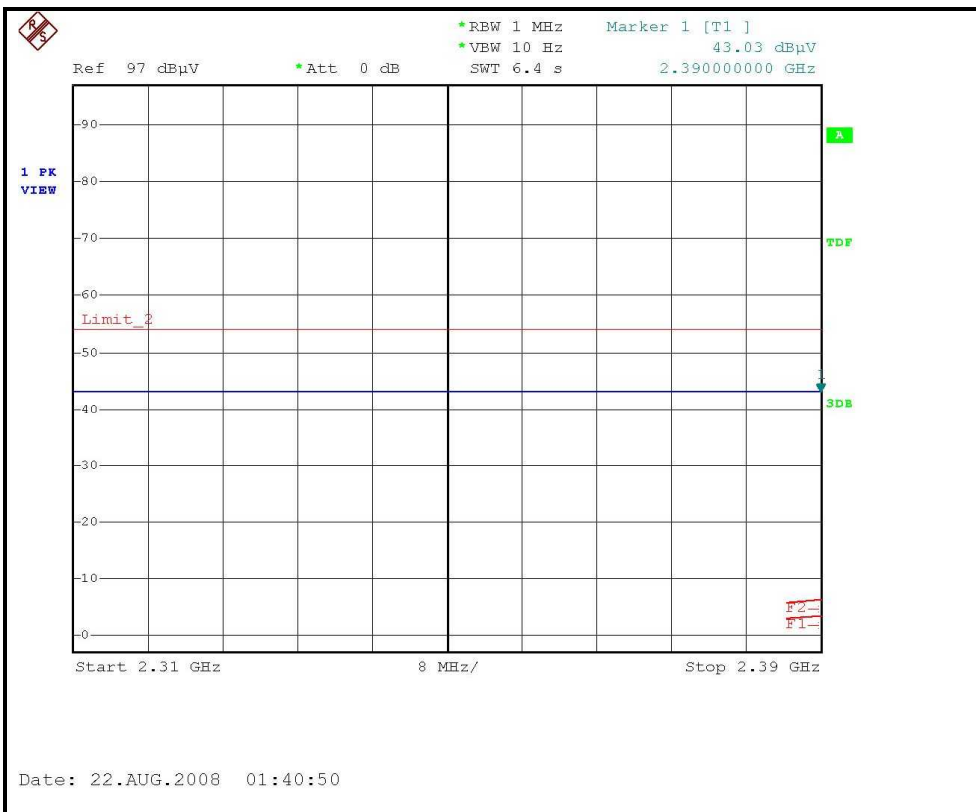
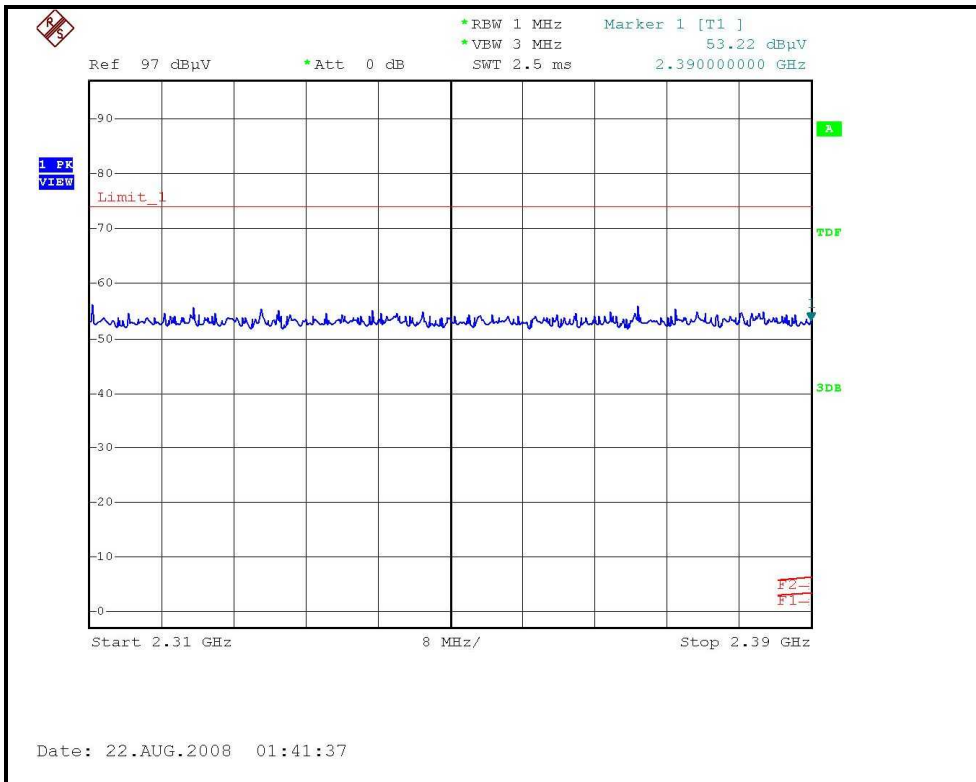

802.11g OFDM MODULATION

EUT TEST CONDITION		MEASUREMENT DETAIL	
CHANNEL	Channel 1	FREQUENCY RANGE	1 ~ 25GHz
INPUT POWER (SYSTEM)	120Vac, 60 Hz	DETECTOR FUNCTION	Peak (PK) Average (AV)
ENVIRONMENTAL CONDITIONS	28deg. C, 64%RH 965hPa	TESTED BY	Frank Liu

ANTENNA POLARITY & TEST DISTANCE: HORIZONTAL AT 3 M								
NO.	FREQ. (MHz)	EMISSION LEVEL (dBuV/m)	LIMIT (dBuV/m)	MARGIN (dB)	ANTENNA HEIGHT (m)	TABLE ANGLE (Degree)	RAW VALUE (dBuV)	CORRECTION FACTOR (dB/m)
1	2390.00	53.80 PK	74.00	-20.20	1.54 H	226	23.74	30.06
2	2390.00	43.36 AV	54.00	-10.64	1.54 H	226	13.30	30.06
3	*2412.00	88.30 PK			1.50 H	230	58.15	30.15
4	*2412.00	77.10 AV			1.50 H	230	46.95	30.15
5	4824.00	44.30 PK	74.00	-29.70	1.43 H	252	8.84	35.46
6	4824.00	32.30 AV	54.00	-21.70	1.43 H	252	-3.16	35.46
7	7236.00	50.60 PK	74.00	-23.40	1.52 H	237	8.75	41.85
8	7236.00	37.20 AV	54.00	-16.80	1.52 H	237	-4.65	41.85
ANTENNA POLARITY & TEST DISTANCE: VERTICAL AT 3 M								
NO.	FREQ. (MHz)	EMISSION LEVEL (dBuV/m)	LIMIT (dBuV/m)	MARGIN (dB)	ANTENNA HEIGHT (m)	TABLE ANGLE (Degree)	RAW VALUE (dBuV)	CORRECTION FACTOR (dB/m)
1	2390.00	65.90 PK	74.00	-8.10	1.18 V	360	35.84	30.06
2	2390.00	48.33 AV	54.00	-5.67	1.18 V	360	18.27	30.06
3	*2412.00	108.80 PK			1.17 V	5	78.65	30.15
4	*2412.00	103.10 AV			1.17 V	5	72.95	30.15
5	4824.00	46.60 PK	74.00	-27.40	1.16 V	114	11.14	35.46
6	4824.00	35.90 AV	54.00	-18.10	1.16 V	114	0.44	35.46
7	7236.00	51.90 PK	74.00	-22.10	1.00 V	126	10.05	41.85
8	7236.00	37.60 AV	54.00	-16.40	1.00 V	126	-4.25	41.85

- REMARKS:**
1. Emission level (dBuV/m) = Raw Value (dBuV) + Correction Factor (dB/m).
 2. Correction Factor (dB/m) = Antenna Factor (dB/m) + Cable Factor (dB).
 3. The other emission levels were very low against the limit.
 4. Margin value = Emission level – Limit value.
 5. “ * “: Fundamental frequency.

EUT TEST CONDITION		MEASUREMENT DETAIL	
CHANNEL	Channel 6	FREQUENCY RANGE	1 ~ 25GHz
INPUT POWER (SYSTEM)	120Vac, 60 Hz	DETECTOR FUNCTION	Peak (PK) Average (AV)
ENVIRONMENTAL CONDITIONS	28deg. C, 64%RH 965hPa	TESTED BY	Frank Liu

ANTENNA POLARITY & TEST DISTANCE: HORIZONTAL AT 3 M								
NO.	FREQ. (MHz)	EMISSION LEVEL (dBuV/m)	LIMIT (dBuV/m)	MARGIN (dB)	ANTENNA HEIGHT (m)	TABLE ANGLE (Degree)	RAW VALUE (dBuV)	CORRECTION FACTOR (dB/m)
1	*2437.00	90.10 PK			1.55 H	223	59.86	30.24
2	*2437.00	80.20 AV			1.55 H	223	49.96	30.24
3	4874.00	45.30 PK	74.00	-28.70	1.82 H	34	9.75	35.55
4	4874.00	33.60 AV	54.00	-20.40	1.82 H	34	-1.95	35.55
5	7311.00	51.20 PK	74.00	-22.80	1.42 H	302	9.16	42.04
6	7311.00	39.10 AV	54.00	-14.90	1.42 H	302	-2.94	42.04
ANTENNA POLARITY & TEST DISTANCE: VERTICAL AT 3 M								
NO.	FREQ. (MHz)	EMISSION LEVEL (dBuV/m)	LIMIT (dBuV/m)	MARGIN (dB)	ANTENNA HEIGHT (m)	TABLE ANGLE (Degree)	RAW VALUE (dBuV)	CORRECTION FACTOR (dB/m)
1	*2437.00	115.60 PK			1.20 V	168	85.36	30.24
2	*2437.00	101.40 AV			1.20 V	168	71.16	30.24
3	4874.00	46.30 PK	74.00	-27.70	1.20 V	139	10.75	35.55
4	4874.00	35.70 AV	54.00	-18.30	1.20 V	139	0.15	35.55
5	7311.00	53.40 PK	74.00	-20.60	1.00 V	125	11.36	42.04
6	7311.00	40.10 AV	54.00	-13.90	1.00 V	125	-1.94	42.04

- REMARKS:**
1. Emission level (dBuV/m) = Raw Value (dBuV) + Correction Factor (dB/m).
 2. Correction Factor (dB/m) = Antenna Factor (dB/m) + Cable Factor (dB).
 3. The other emission levels were very low against the limit.
 4. Margin value = Emission level – Limit value.
 5. “ * “: Fundamental frequency.



EUT TEST CONDITION		MEASUREMENT DETAIL	
CHANNEL	Channel 11	FREQUENCY RANGE	1 ~ 25GHz
INPUT POWER (SYSTEM)	120Vac, 60 Hz	DETECTOR FUNCTION	Peak (PK) Average (AV)
ENVIRONMENTAL CONDITIONS	28deg. C, 64%RH 965hPa	TESTED BY	Frank Liu

ANTENNA POLARITY & TEST DISTANCE: HORIZONTAL AT 3 M

NO.	FREQ. (MHz)	EMISSION LEVEL (dBuV/m)	LIMIT (dBuV/m)	MARGIN (dB)	ANTENNA HEIGHT (m)	TABLE ANGLE (Degree)	RAW VALUE (dBuV)	CORRECTION FACTOR (dB/m)
1	*2462.00	87.80 PK			1.54 H	226	57.46	30.34
2	*2462.00	76.60 AV			1.54 H	226	46.26	30.34
3	2483.50	53.34 PK	74.00	-20.66	1.54 H	226	22.91	30.43
4	2483.50	43.41 AV	54.00	-10.59	1.54 H	226	12.98	30.43
5	4924.00	42.30 PK	74.00	-31.70	1.53 H	270	6.67	35.63
6	4924.00	31.20 AV	54.00	-22.80	1.53 H	270	-4.43	35.63
7	7386.00	49.30 PK	74.00	-24.70	1.37 H	213	7.07	42.23
8	7386.00	36.80 AV	54.00	-17.20	1.37 H	213	-5.43	42.23

ANTENNA POLARITY & TEST DISTANCE: VERTICAL AT 3 M

NO.	FREQ. (MHz)	EMISSION LEVEL (dBuV/m)	LIMIT (dBuV/m)	MARGIN (dB)	ANTENNA HEIGHT (m)	TABLE ANGLE (Degree)	RAW VALUE (dBuV)	CORRECTION FACTOR (dB/m)
1	*2462.00	109.84 PK			1.22 V	357	79.50	30.34
2	*2462.00	98.00 AV			1.22 V	357	67.66	30.34
3	2483.50	68.97 PK	74.00	-5.03	1.25 V	357	38.54	30.43
4	2483.50	50.72 AV	54.00	-3.28	1.25 V	357	20.29	30.43
5	4924.00	43.10 PK	74.00	-30.90	1.10 V	137	7.47	35.63
6	4924.00	32.60 AV	54.00	-21.40	1.10 V	137	-3.03	35.63
7	7386.00	50.30 PK	74.00	-23.70	1.00 V	112	8.07	42.23
8	7386.00	37.20 AV	54.00	-16.80	1.00 V	112	-5.03	42.23

- REMARKS:**
1. Emission level (dBuV/m) = Raw Value (dBuV) + Correction Factor (dB/m).
 2. Correction Factor (dB/m) = Antenna Factor (dB/m) + Cable Factor (dB).
 3. The other emission levels were very low against the limit.
 4. Margin value = Emission level – Limit value.
 5. “ * “: Fundamental frequency.

4.3 6dB BANDWIDTH MEASUREMENT

4.3.1 LIMITS OF 6dB BANDWIDTH MEASUREMENT

The minimum of 6dB Bandwidth Measurement is 0.5 MHz.

4.3.2 TEST INSTRUMENTS

Description & Manufacturer	Model No.	Serial No.	Calibrated Until
R&S SPECTRUM ANALYZER	FSP40	100036	Dec. 17, 2008

NOTE:

- 1.The measurement uncertainty is less than +/- 2.6dB, which is calculated as per the NAMAS document NIS81.
- 2.The calibration interval of the above test instruments is 12 months and the calibrations are traceable to NML/ROC and NIST/USA.

4.3.3 TEST PROCEDURE

The transmitter output was connected to the spectrum analyzer through an attenuator. The bandwidth of the fundamental frequency was measured by spectrum analyzer with 100 kHz RBW and 100 kHz VBW. The 6 dB bandwidth is defined as the total spectrum the power of which is higher than peak power minus 6 dB.

4.3.4 TEST SETUP

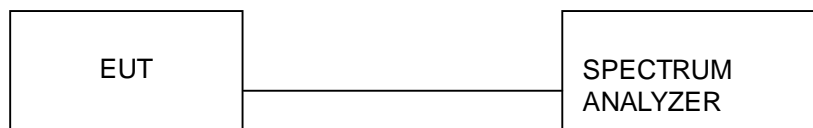

For the actual test configuration, please refer to the related Item – Photographs of the Test Configuration.

4.3.5 EUT OPERATING CONDITIONS

The software provided by client to enable the EUT under transmission condition continuously at lowest, middle and highest channel frequencies individually.



4.3.6 TEST RESULTS

802.11b DSSS modulation

MODULATION TYPE	DBPSK	TRANSFER RATE	1Mbps
INPUT POWER	120Vac, 60 Hz	ENVIRONMENTAL CONDITIONS	25deg. C, 60%RH, 965hPa
TESTED BY	Wen Yu		

CHANNEL	CHANNEL FREQUENCY (MHz)	6 dB BANDWIDTH (MHz)	MINIMUM LIMIT (MHz)	PASS/FAIL
1	2412	12.24	0.5	PASS
6	2437	11.42	0.5	PASS
11	2462	11.72	0.5	PASS

CH1

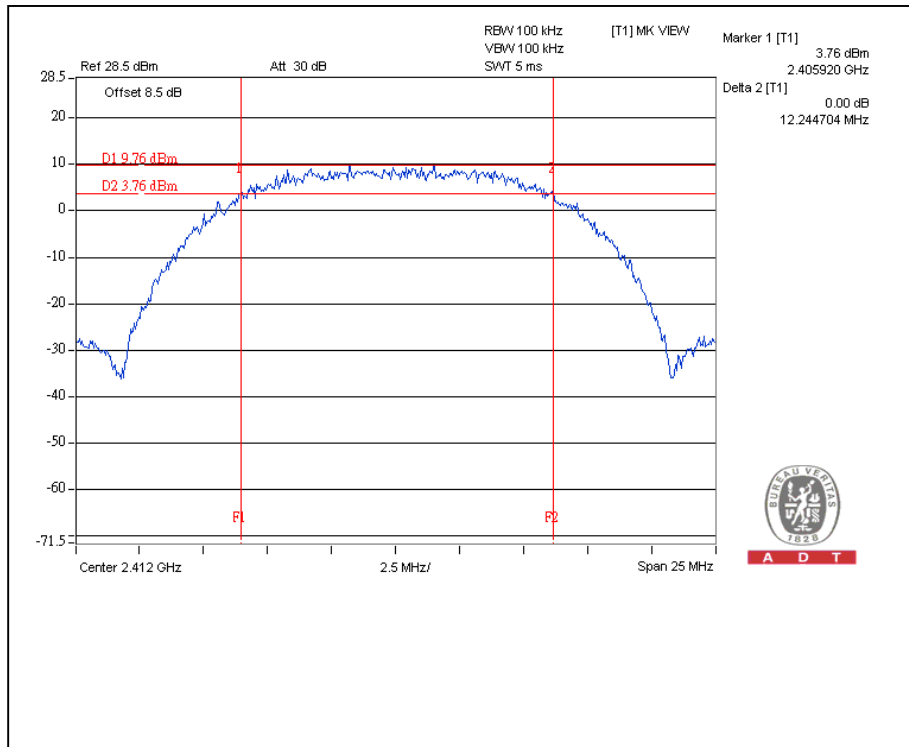

CH6

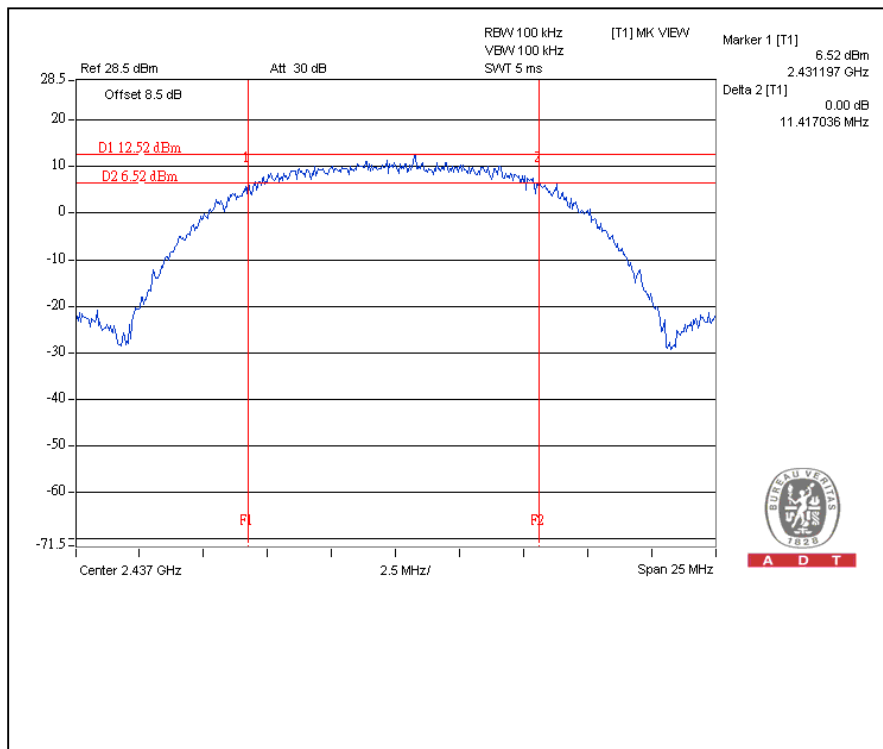

CH11

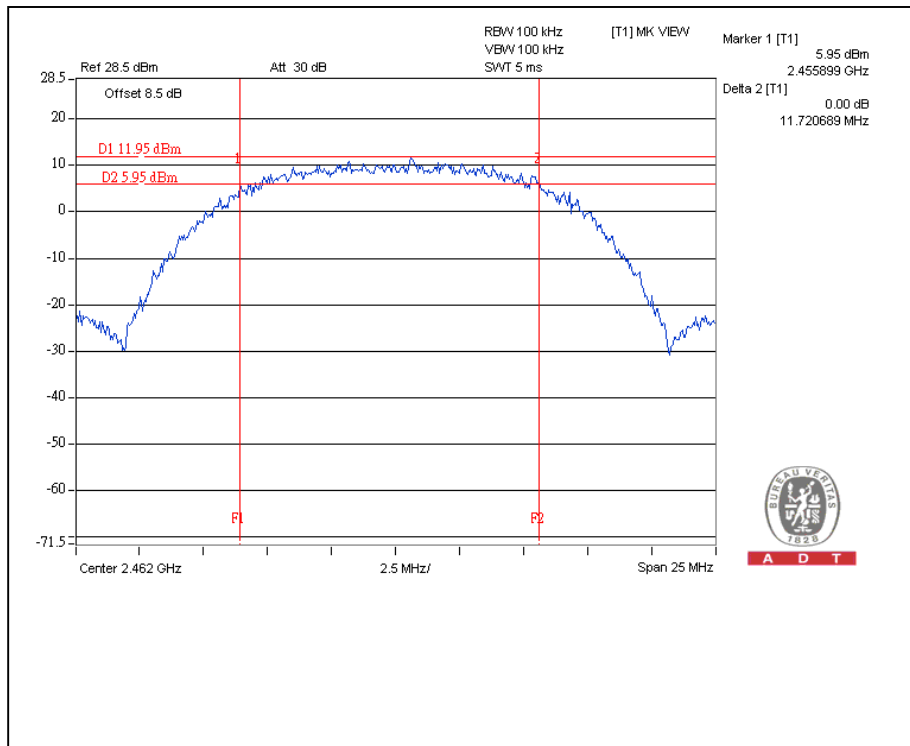



802.11g OFDM modulation

MODULATION TYPE	BPSK	TRANSFER RATE	6Mbps
INPUT POWER	120Vac, 60 Hz	ENVIRONMENTAL CONDITIONS	25deg. C, 60%RH, 965hPa
TESTED BY	Wen Yu		

CHANNEL	CHANNEL FREQUENCY (MHz)	6 dB BANDWIDTH (MHz)	MINIMUM LIMIT (MHz)	PASS/FAIL
1	2412	16.41	0.5	PASS
6	2437	16.38	0.5	PASS
11	2462	16.42	0.5	PASS

CH1

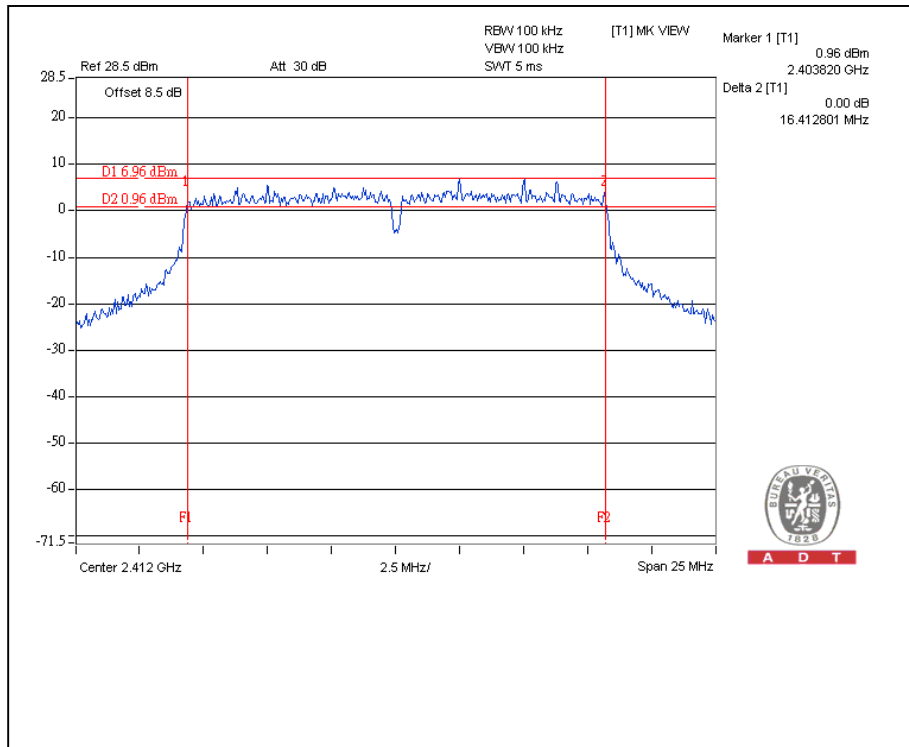

CH6

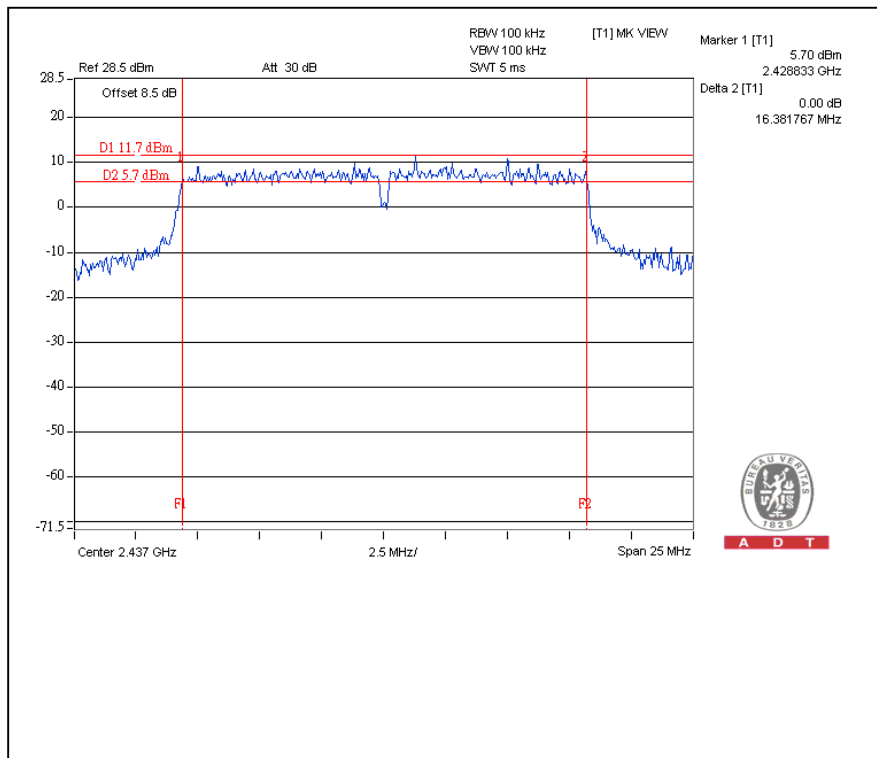

CH11

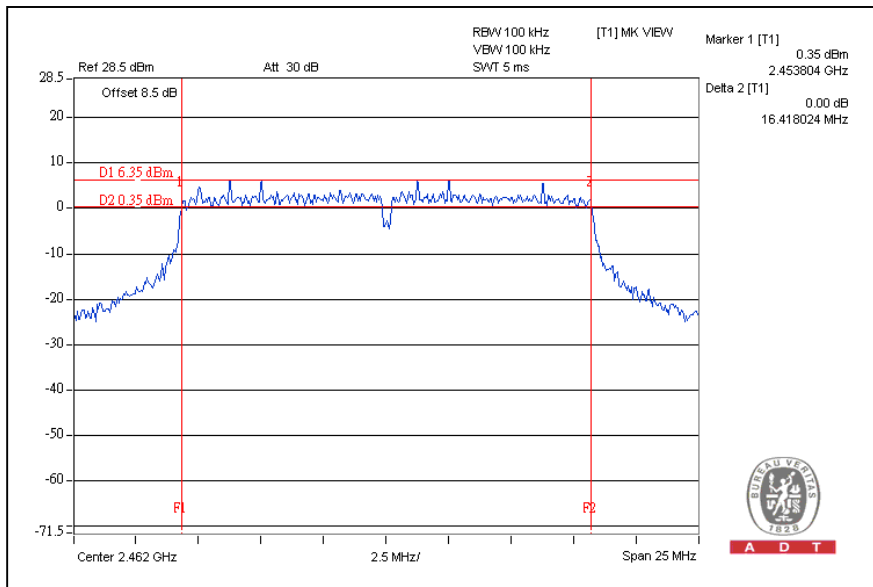

4.4 MAXIMUM PEAK OUTPUT POWER

4.4.1 LIMITS OF MAXIMUM PEAK OUTPUT POWER MEASUREMENT

The Maximum Peak Output Power Measurement is 30dBm.

4.4.2 TEST INSTRUMENTS

Description & Manufacturer	Model No.	Serial No.	Calibrated Until
R&S SPECTRUM ANALYZER	FSP40	100036	Dec. 17, 2008
Agilent SIGNAL GENERATOR	E8257C	MY43320668	Dec. 07, 2008
TEKTRONIX OSCILLOSCOPE	TDS380	B016335	July. 20, 2009
NARDA DETECTOR	4503A	FSCM99899	NA

NOTE:

The calibration interval of the above test instruments is 12 months and the calibrations are traceable to NML/ROC and NIST/USA.

4.4.3 TEST PROCEDURES

1. A detector was used on the output port of the EUT. An oscilloscope was used to read the peak response of the detector.
2. Replaced the EUT by the signal generator. The center frequency of the S.G was adjusted to the center frequency of the measured channel.
3. Adjusted the power to have the same peak reading on oscilloscope. Record the power level.

4.4.4 TEST SETUP

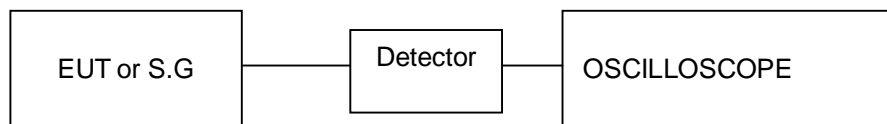

4.4.5 EUT OPERATING CONDITIONS

Same as Item 4.3.5



4.4.6 TEST RESULTS - With antenna 3

802.11b DSSS modulation

MODULATION TYPE	DBPSK	TRANSFER RATE	1Mbps
INPUT POWER	120Vac, 60Hz	ENVIRONMENTAL CONDITIONS	26deg. C, 64%RH, 965hPa
TESTED BY	Rex Huang		

CHANNEL	CHANNEL FREQUENCY (MHz)	PEAK POWER OUTPUT (mW)	PEAK POWER OUTPUT (dBm)	PEAK POWER LIMIT (dBm)	PASS/FAIL
1	2412	86.696	19.38	30	PASS
6	2437	223.872	23.50	30	PASS
11	2462	79.433	19.00	30	PASS



802.11g OFDM modulation

MODULATION TYPE	BPSK	TRANSFER RATE	6Mbps
INPUT POWER	120Vac, 60Hz	ENVIRONMENTAL CONDITIONS	26deg. C, 64%RH, 965hPa
TESTED BY	Rex Huang		

CHANNEL	CHANNEL FREQUENCY (MHz)	PEAK POWER OUTPUT (mW)	PEAK POWER OUTPUT (dBm)	PEAK POWER LIMIT (dBm)	PASS/FAIL
1	2412	115.611	20.63	30	PASS
6	2437	354.813	25.50	30	PASS
11	2462	100.000	20.00	30	PASS



4.4.7 TEST RESULTS - With antenna 4

802.11b DSSS modulation

MODULATION TYPE	DBPSK	TRANSFER RATE	1Mbps
INPUT POWER	120Vac, 60Hz	ENVIRONMENTAL CONDITIONS	25deg. C, 60%RH, 965hPa
TESTED BY	Wen Yu		

CHANNEL	CHANNEL FREQUENCY (MHz)	PEAK POWER OUTPUT (mW)	PEAK POWER OUTPUT (dBm)	PEAK POWER LIMIT (dBm)	PASS/FAIL
1	2412	169.824	22.30	30	PASS
6	2437	239.883	23.80	30	PASS
11	2462	223.872	23.50	30	PASS



802.11g OFDM modulation

MODULATION TYPE	BPSK	TRANSFER RATE	6Mbps
INPUT POWER	120Vac, 60Hz	ENVIRONMENTAL CONDITIONS	25deg. C, 60%RH, 965hPa
TESTED BY	Wen Yu		

CHANNEL	CHANNEL FREQUENCY (MHz)	PEAK POWER OUTPUT (mW)	PEAK POWER OUTPUT (dBm)	PEAK POWER LIMIT (dBm)	PASS/FAIL
1	2412	138.038	21.40	30	PASS
6	2437	208.930	23.20	30	PASS
11	2462	147.911	21.70	30	PASS

4.5 POWER SPECTRAL DENSITY MEASUREMENT

4.5.1 LIMITS OF POWER SPECTRAL DENSITY MEASUREMENT

The Maximum of Power Spectral Density Measurement is 8dBm.

4.5.2 TEST INSTRUMENTS

Description & Manufacturer	Model No.	Serial No.	Calibrated Until
R&S SPECTRUM ANALYZER	FSP40	100036	Dec. 17, 2008

NOTE:

- 1.The measurement uncertainty is less than +/- 2.6dB, which is calculated as per the NAMAS document NIS81.
- 2.The calibration interval of the above test instruments is 12 months and the calibrations are traceable to NML/ROC and NIST/USA.

4.5.3 TEST PROCEDURE

The transmitter output was connected to the spectrum analyzer through an attenuator, the bandwidth of the fundamental frequency was measured with the spectrum analyzer using 3 kHz RBW and 30 kHz VBW, set sweep time= $\text{span}/3\text{kHz}$. The power spectral density was measured and recorded. The sweep time is allowed to be longer than $\text{span}/3\text{kHz}$ for a full response of the mixer in the spectrum analyzer.

4.5.4 TEST SETUP

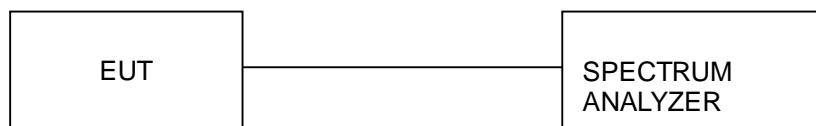

4.5.5 EUT OPERATING CONDITIONS

Same as 4.3.5



4.5.6 TEST RESULTS

802.11b DSSS modulation

MODULATION TYPE	DBPSK	TRANSFER RATE	1Mbps
INPUT POWER	120Vac, 60Hz	ENVIRONMENTAL CONDITIONS	25deg. C, 60%RH, 965hPa
TESTED BY	Wen Yu		

CHANNEL NUMBER	CHANNEL FREQUENCY (MHz)	RF POWER LEVEL IN 3 KHz BW (dBm)	MAXIMUM LIMIT (dBm)	PASS/FAIL
1	2412	-3.82	8	PASS
6	2437	2.17	8	PASS
11	2462	0.02	8	PASS

CH1

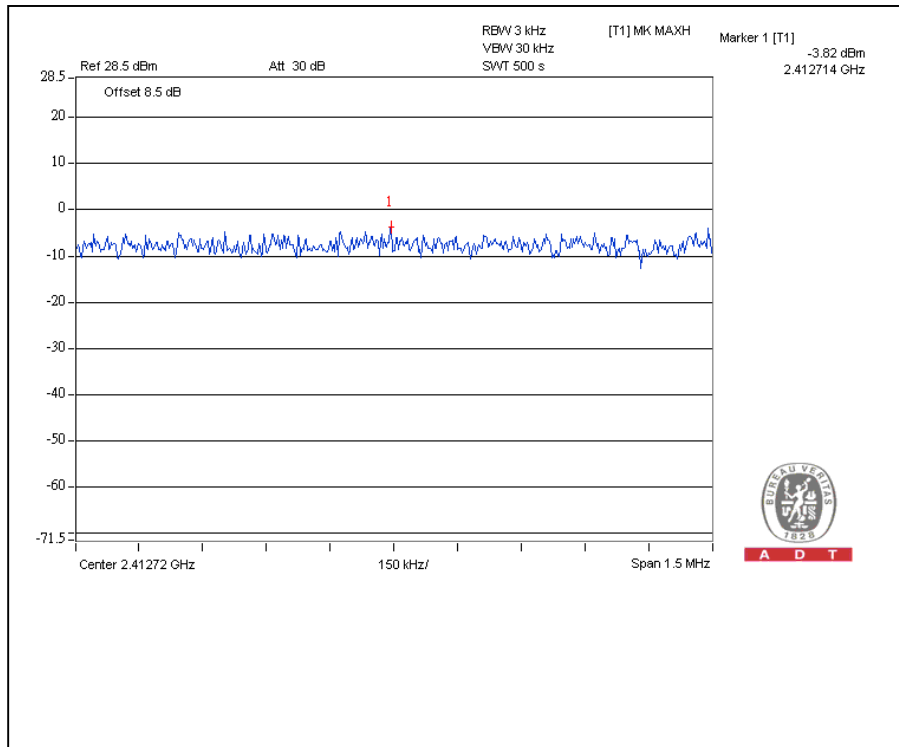

CH6

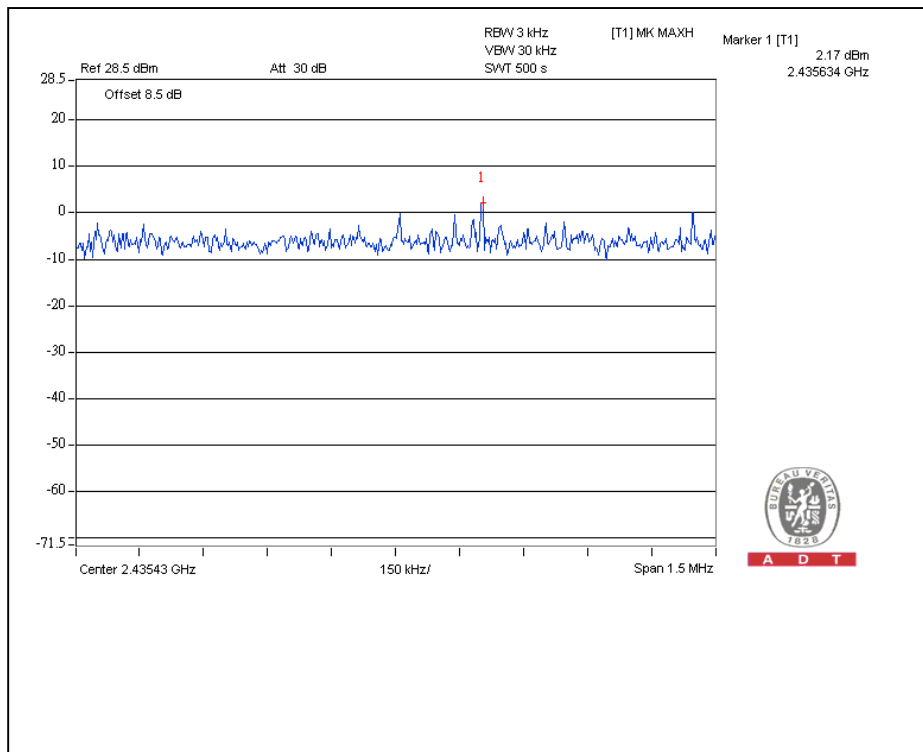

CH11

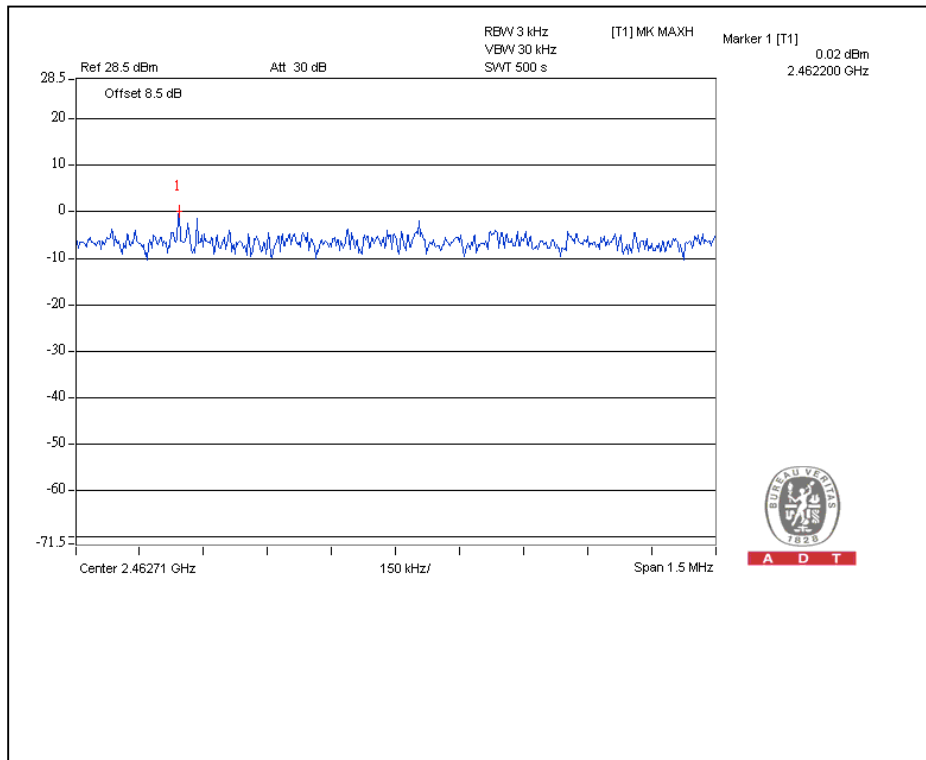



802.11g OFDM modulation

MODULATION TYPE	BPSK	TRANSFER RATE	6Mbps
INPUT POWER	120Vac, 60Hz	ENVIRONMENTAL CONDITIONS	25deg. C, 60%RH, 965hPa
TESTED BY	Wen Yu		

CHANNEL NUMBER	CHANNEL FREQUENCY (MHz)	RF POWER LEVEL IN 3 KHz BW (dBm)	MAXIMUM LIMIT (dBm)	PASS/FAIL
1	2412	-7.59	8	PASS
6	2437	-3.50	8	PASS
11	2462	-7.87	8	PASS

CH11

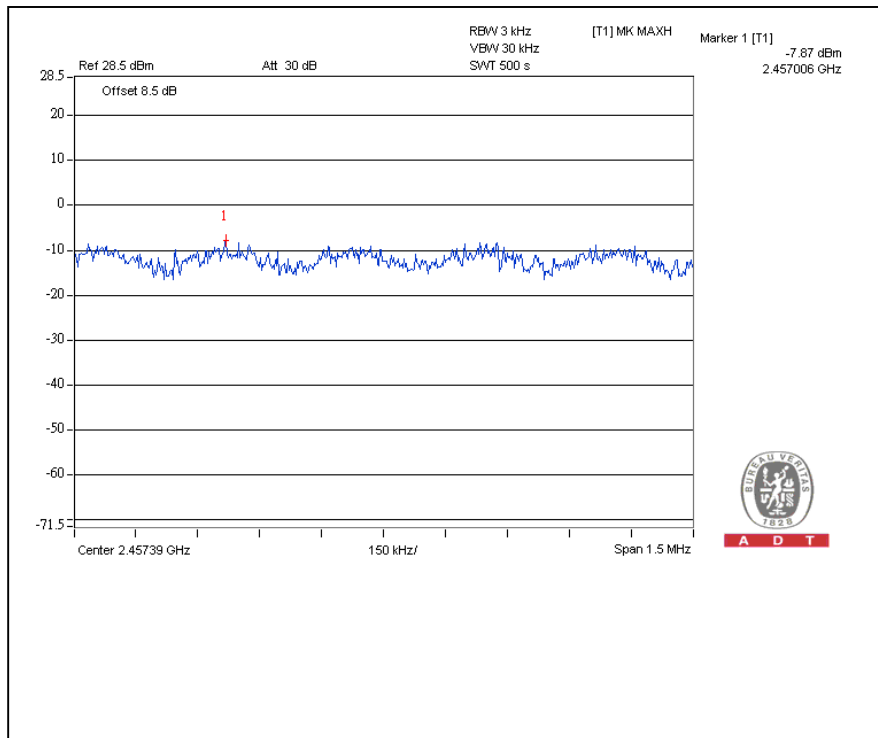

4.6 CONDUCTED OUT-BAND EMISSION MEASUREMENT

4.6.1 LIMITS OF CONDUCTED OUT-BAND EMISSION MEASUREMENT

Below -20dB of the highest emission level of operating band (in 100KHz Resolution Bandwidth).

4.6.2 TEST INSTRUMENTS

Description & Manufacturer	Model No.	Serial No.	Calibrated Until
R&S SPECTRUM ANALYZER	FSP40	100036	Dec. 17, 2008

NOTE:

- 1.The measurement uncertainty is less than $\pm 2.6\text{dB}$, which is calculated as per the NAMAS document NIS81.
- 2.The calibration interval of the above test instruments is 12 months and the calibrations are traceable to NML/ROC and NIST/USA.

4.6.3 TEST PROCEDURE

The transmitter output was connected to the spectrum analyzer via a low loss cable. Set RBW of spectrum analyzer to 100kHz and VBW of spectrum analyzer to 300kHz with suitable frequency span including 100 MHz bandwidth from band edge. The band edges was measured and recorded.

The spectrum plots (RBW =100kHz ; VBW = 300kHz) are attached on the following pages.

4.6.4 EUT OPERATING CONDITION

Same as Item 4.3.5



4.6.5 TEST RESULTS

The spectrum plots are attached on the following pages. D1 line indicates the highest level, and D2 line indicates the 20dB offset below D1. It shows compliance with the requirement in part 15.247(d).

**802.11b DSSS MODULATION:
CH1**

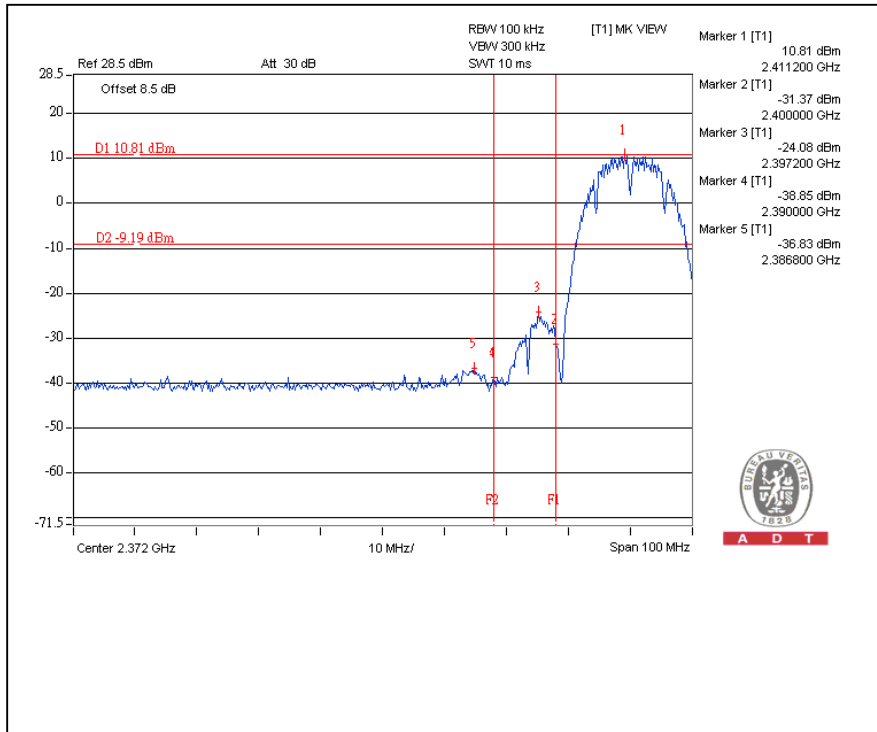

CH11

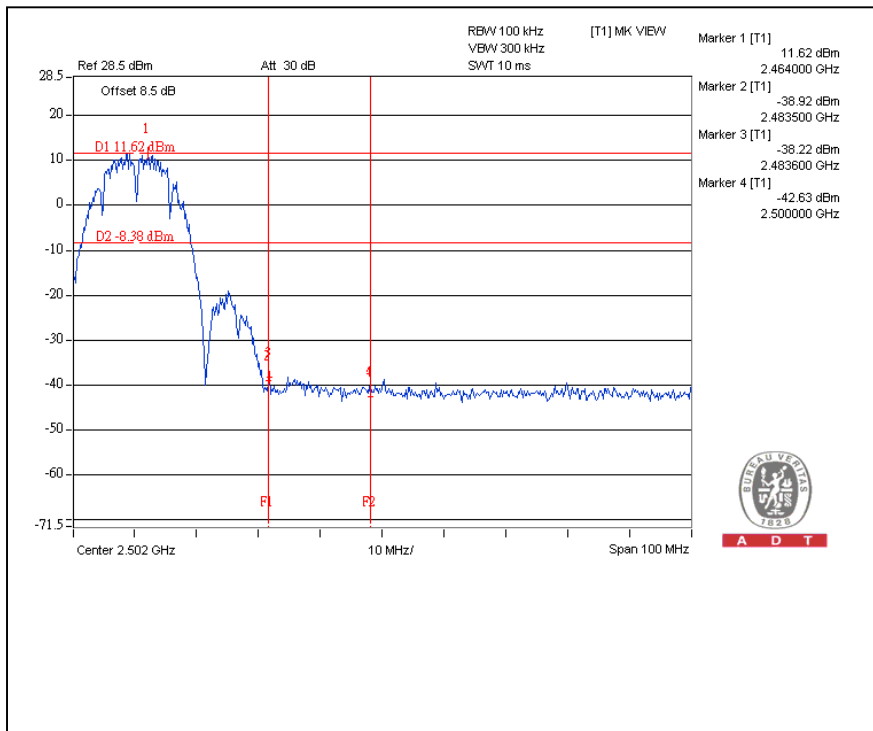

CH1

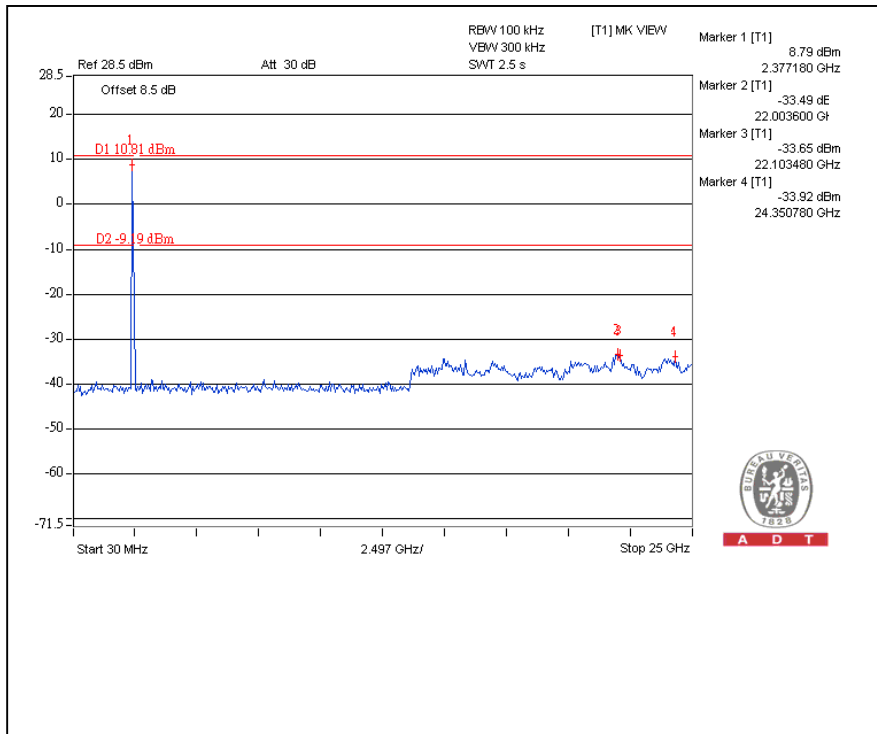

CH11

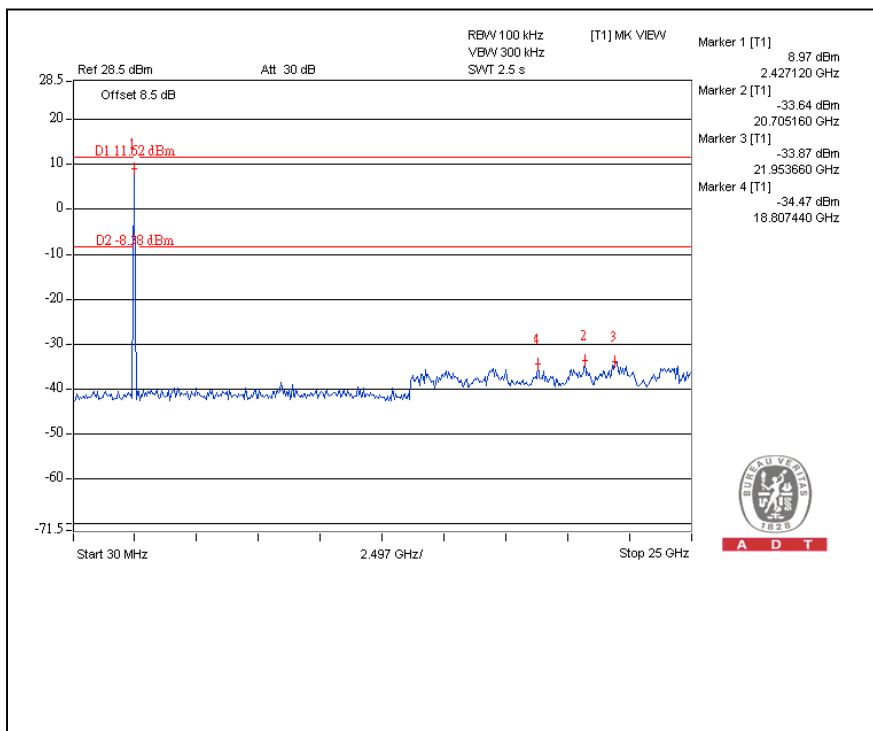

802.11g OFDM MODULATION: CH1

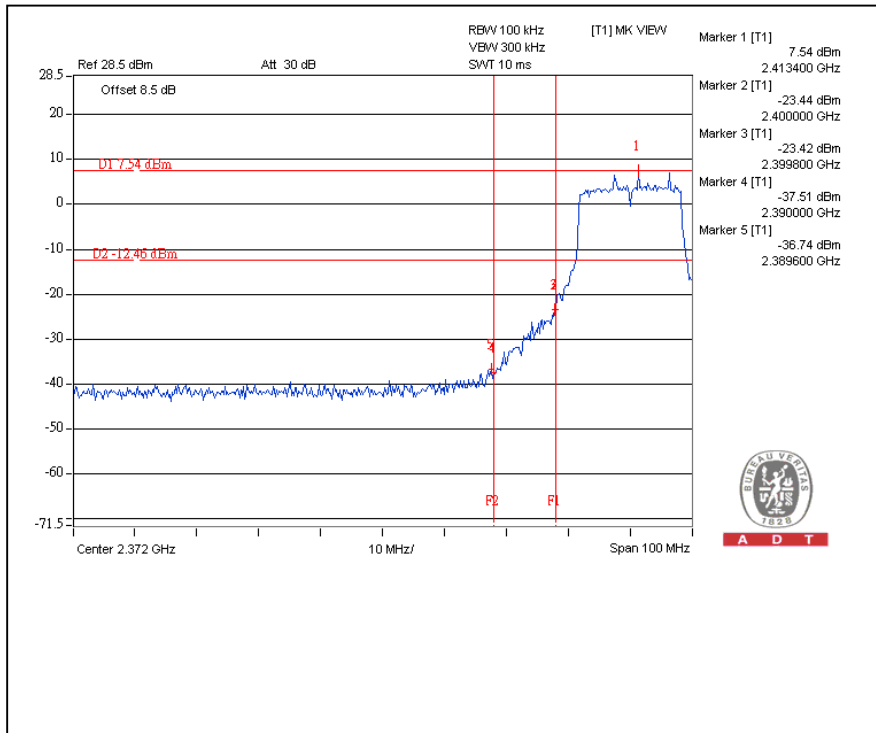

CH11

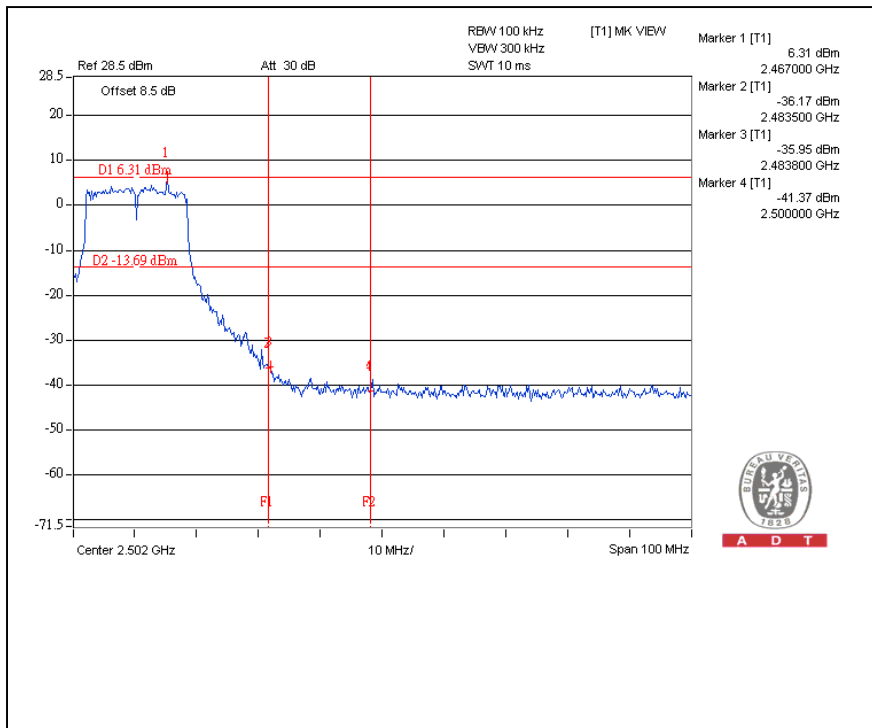

CH1

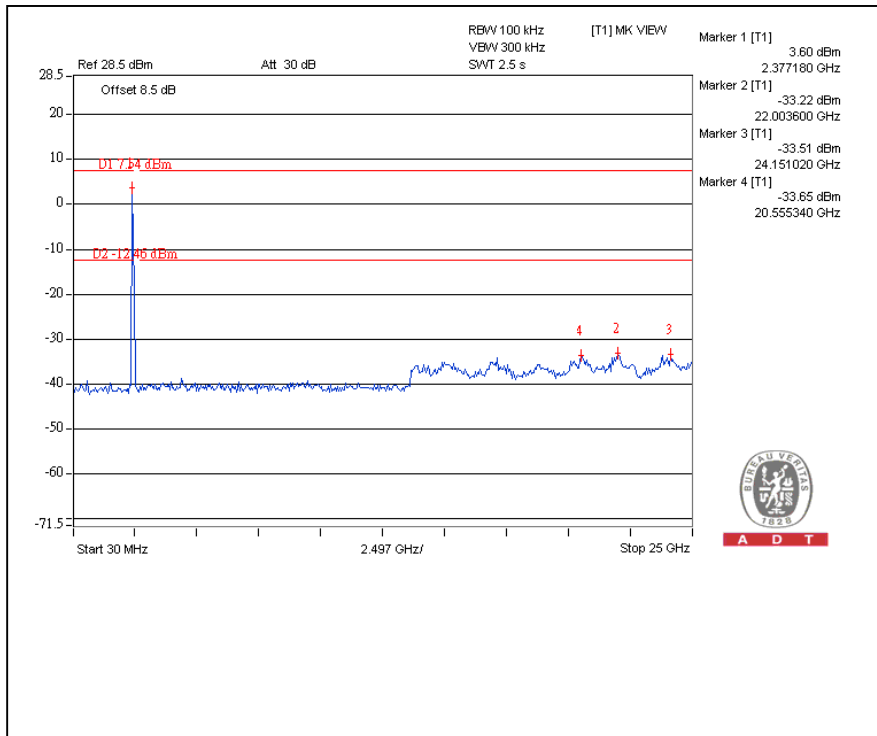

CH11

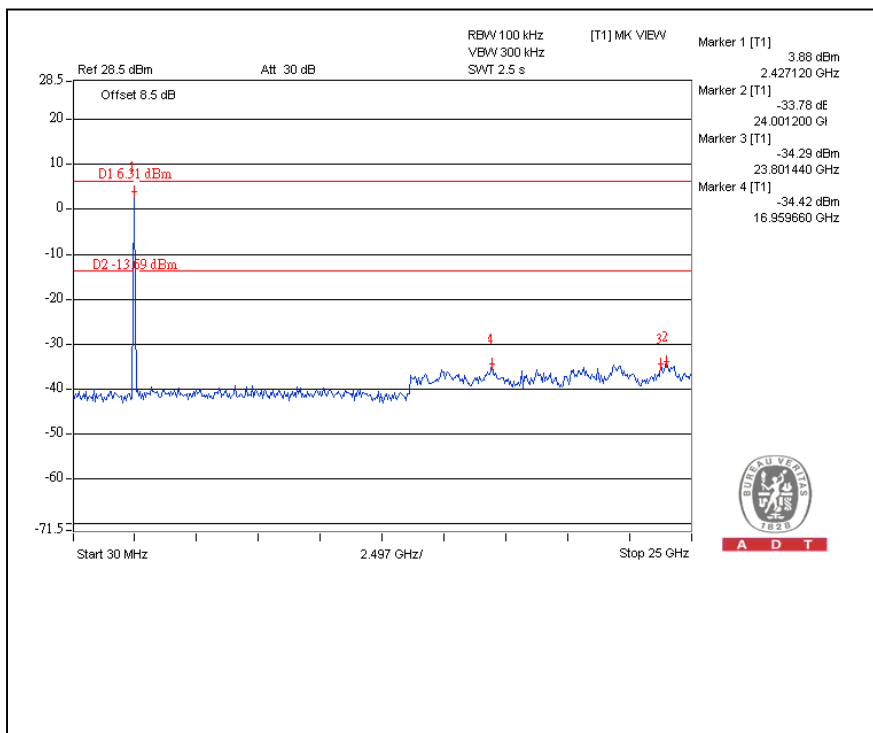

4.7 ANTENNA REQUIREMENT

4.7.1 STANDARD APPLICABLE

For intentional device, according to FCC 47 CFR Section 15.203, an intentional radiator shall be designed to ensure that no antenna other than that furnished by the responsible party shall be used with the device.

And according to FCC 47 CFR Section 15.247 (b), if transmitting antennas of directional gain greater than 6dBi are used, the power shall be reduced by the amount in dB that the directional gain of the antenna exceeds 6dBi.

4.7.2 ANTENNA CONNECTED CONSTRUCTION

The antennas used in this product are as below:

Antenna Type	Gain (dBi)	Cable lose(dB)	Arrester lose(dB)	Net Gain (dBi)	Antenna Connector
Dipole, Omni-Directional	12	7.6523	0.8	3.5477	N female
Yagi, directional	21	16.811	0.8	3.389	N female

5 INFORMATION ON THE TESTING LABORATORIES

We, ADT Corp., were founded in 1988 to provide our best service in EMC, Radio, Telecom and Safety consultation. Our laboratories are accredited and approved by the following approval agencies according to ISO/IEC 17025:

USA	FCC, UL
Germany	TUV Rheinland
Japan	VCCI
Norway	NEMKO
Canada	INDUSTRY CANADA, CSA
R.O.C.	TAF, BSMI, NCC
Netherlands	Telefication
Singapore	GOST-ASIA (MOU)
Russia	CERTIS (MOU)

Copies of accreditation certificates of our laboratories obtained from approval agencies can be downloaded from our web site: www.adt.com.tw/index.5/phtml.

If you have any comments, please feel free to contact us at the following:

Linko EMC/RF Lab:

Tel: 886-2-26052180

Fax: 886-2-26052943

Hsin Chu EMC/RF Lab:

Tel: 886-3-5935343

Fax: 886-3-5935342

Hwa Ya EMC/RF/Safety/Telecom Lab:

Tel: 886-3-3183232

Fax: 886-3-3185050

Email: service@adt.com.tw

Web Site: www.adt.com.tw

The address and road map of all our labs can be found in our web site also.

6 APPENDIX A - MODIFICATIONS RECORDERS FOR ENGINEERING CHANGES TO THE EUT BY THE LAB

No any modifications are made to the EUT by the lab during the test.

--- EMD ---