



# FCC TEST REPORT

**REPORT NO.:** RF950302L18A

**MODEL NO.:** DWA-642

**RECEIVED:** May 26, 2006

**TESTED:** Oct. 18 ~ 24, 2006

**ISSUED:** Nov. 08, 2006

**APPLICANT:** D-Link Corporation

**ADDRESS:** 17595 Mt. Herrmann, Fountain Valley, CA  
92708, U.S.A.

**ISSUED BY:** Advance Data Technology Corporation

**LAB ADDRESS:** 47 14<sup>th</sup> Lin, Chiapau Tsun, Linko, Taipei, Taiwan,  
R.O.C.

**TEST LOCATION:** No. 19, Hwa Ya 2<sup>nd</sup> Rd., Kueishan, Taoyuan,  
Taiwan, R.O.C.

This test report consists of 57 pages in total. It may be duplicated completely for legal use with the approval of the applicant. It should not be reproduced except in full, without the written approval of our laboratory. The client should not use it to claim product endorsement by CNLA, A2LA or any government agencies. The test results in the report only apply to the tested sample.



## TABLE OF CONTENTS

1.	CERTIFICATION .....	3
2.	SUMMARY OF TEST RESULTS .....	4
2.1	MEASUREMENT UNCERTAINTY .....	4
3.	GENERAL INFORMATION .....	5
3.1	GENERAL DESCRIPTION OF EUT .....	5
3.2	DESCRIPTION OF TEST MODES .....	6
3.2.1	CONFIGURATION OF SYSTEM UNDER TEST .....	6
3.2.2	TEST MODE APPLICABILITY AND TESTED CHANNEL DETAIL .....	7
3.3	GENERAL DESCRIPTION OF APPLIED STANDARDS .....	9
3.4	DESCRIPTION OF SUPPORT UNITS.....	10
4.	TEST TYPES AND RESULTS .....	11
4.1	CONDUCTED EMISSION MEASUREMENT .....	11
4.1.1	LIMITS OF CONDUCTED EMISSION MEASUREMENT .....	11
4.1.2	TEST INSTRUMENTS.....	11
4.1.3	TEST PROCEDURES .....	12
4.1.4	DEVIATION FROM TEST STANDARD .....	12
4.1.5	TEST SETUP .....	13
4.1.6	EUT OPERATING CONDITIONS .....	13
4.1.7	TEST RESULTS .....	14
4.2	RADIATED EMISSION MEASUREMENT .....	32
4.2.1	LIMITS OF RADIATED EMISSION MEASUREMENT.....	32
4.2.2	TEST INSTRUMENTS.....	33
4.2.3	TEST PROCEDURES .....	34
4.2.4	DEVIATION FROM TEST STANDARD .....	34
4.2.5	TEST SETUP .....	35
4.2.6	EUT OPERATING CONDITIONS .....	35
4.2.7	TEST RESULTS .....	36
4.3	MAXIMUM PEAK OUTPUT POWER.....	51
4.3.1	LIMITS OF MAXIMUM PEAK OUTPUT POWER MEASUREMENT .....	51
4.3.2	INSTRUMENTS.....	51
4.3.3	TEST PROCEDURES .....	51
4.3.4	DEVIATION FROM TEST STANDARD .....	51
4.3.5	TEST SETUP .....	52
4.3.6	EUT OPERATING CONDITIONS .....	52
4.3.7	TEST RESULTS .....	53
6.	INFORMATION ON THE TESTING LABORATORIES .....	56
	APPENDIX-A .....	A-1



## 1. CERTIFICATION

**PRODUCT:** D-Link DWA-642 RangeBooster N™ 650 Notebook Adapter  
**MODEL:** DWA-642  
**BRAND:** D-Link  
**APPLICANT:** D-Link Corporation  
**TESTED:** Oct. 18 ~ 24, 2006  
**TEST SAMPLE:** ENGINEERING SAMPLE  
**STANDARDS:** FCC Part 15, Subpart C (Section 15.247), ANSI C63.4-2003

The above equipment has been tested by **Advance Data Technology Corporation**, and found compliance with the requirement of the above standards. The test record, data evaluation & Equipment Under Test (EUT) configurations represented herein are true and accurate accounts of the measurements of the sample's EMC characteristics under the conditions specified in this report.

**PREPARED BY** : Rennie Wang , **DATE:** Nov. 08, 2006  
Rennie Wang

**TECHNICAL ACCEPTANCE** : Long Chen , **DATE:** Nov. 08, 2006  
Responsible for RF Long Chen

**APPROVED BY** : Gary Chang , **DATE:** Nov. 08, 2006  
Gary Chang / Supervisor

## 2. SUMMARY OF TEST RESULTS

The EUT has been tested according to the following specifications:

APPLIED STANDARD: FCC Part 15, Subpart C			
STANDARD SECTION	TEST TYPE AND LIMIT	RESULT	REMARK
15.207	AC Power Conducted Emission	PASS	Meet the requirement of limit. Minimum passing margin is -18.98dB at 0.220MHz.
15.247(d)	Transmitter Radiated Emissions Limit: Table 15.209	PASS	Meet the requirement of limit. Minimum passing margin is -1.00dB at 2386.00MHz.
15.247(b)	Maximum Peak Output Power Limit: max. 30dBm	PASS	Meet the requirement of limit.

### 2.1 MEASUREMENT UNCERTAINTY

Where relevant, the following measurement uncertainty levels have been estimated for tests performed on the EUT as specified in CISPR 16-4:

MEASUREMENT	FREQUENCY	UNCERTAINTY
Conducted emissions	9kHz ~ 30MHz	2.44dB
Radiated emissions	30MHz ~ 200MHz	3.59dB
	200MHz ~ 1000MHz	3.61dB
	1GHz ~ 18GHz	2.26dB
	18GHz ~ 40GHz	1.94dB

This uncertainty represents an expanded uncertainty expressed at approximately the 95% confidence level using a coverage factor of  $k = 2$ .

### 3. GENERAL INFORMATION

#### 3.1 GENERAL DESCRIPTION OF EUT

<b>PRODUCT</b>	D-Link DWA-642 RangeBooster N <sup>TM</sup> 650 Notebook Adapter
<b>MODEL NO.</b>	DWA-642
<b>FCC ID</b>	KA2DWA645B1
<b>POWER SUPPLY</b>	3.3Vdc from host equipment
<b>MODULATION TYPE</b>	CCK, DQPSK, DBPSK for DSSS 64QAM, 16QAM, QPSK, BPSK for OFDM
<b>MODULATION TECHNOLOGY</b>	DSSS, OFDM
<b>TRANSFER RATE</b>	802.11b: 11/ 5.5/ 2/ 1Mbps 802.11g: 54/ 48/ 36/ 24/ 18/ 12/ 9/ 6Mbps Draft 802.11n (20MHz): 144.444/ 130.000/ 115.556/ 86.667/ 57.778/ 43.333/ 28.889/ 14.444/ 72.2/ 65.0/ 57.8/ 43.3/ 28.9/ 21.7/ 14.4/ 7.2Mbps Draft 802.11n (40MHz): 300/ 270/ 240/ 180/ 120/ 90/ 60/ 30/ 150/ 135/ 120/ 90/ 60/ 45/ 30/ 15Mbps
<b>FREQUENCY RANGE</b>	2412MHz ~ 2462MHz
<b>NUMBER OF CHANNEL</b>	11 for 802.11b, 802.11g, draft 802.11n (20MHz) 7 for draft 802.11n (40MHz)
<b>MAXIMUM OUTPUT POWER</b>	159.415mW
<b>ANTENNA TYPE</b>	PIFA antenna with 2.25dBi gain (Left) PIFA antenna with 2.14dBi gain (Right) Printed antenna with 2.04dBi gain (Middle)
<b>DATA CABLE</b>	NA
<b>I/O PORTS</b>	NA

**NOTE:**

1. This report is issued as a supplementary report of RF950302L18. This report shall be combined together with its original report.
2. This report is prepared for FCC class II permissive change. The differences are adding new antenna to this EUT for the test. Only conducted emission, radiated emission and output power had been presented in this report.
3. The EUT incorporates a MIMO function with 802.11b, 802.11g, draft 802.11n. Physically, the card provides two completed transmitters and three receivers.
4. The EUT is 2 \* 3 spatial MIMO (2Tx & 3Rx) without beam forming function.
5. When the EUT operating in 802.11b, 802.11g, the software operation, which is defined by manufacturer, only set single Tx.
6. When the EUT operating in draft 802.11n, the software operation, which is defined by manufacturer, only set 0 ~ 7 of "MCS" (MCS: Modulation and Coding Schemes) for single Tx, 8 ~ 15 for dual Tx.
7. The EUT complies with draft 802.11n standards and backwards compatible with 802.11b,

802.11g products.

8. The EUT operates in the 2.4GHz frequency spectrum with throughput of up to 300Mbps.
9. The above EUT information was declared by manufacturer and for more detailed features description, please refer to the manufacturer's specifications or user's manual.

### 3.2 DESCRIPTION OF TEST MODES

Eleven channels are provided for 802.11b, 802.11g and draft 802.11n (20MHz):

CHANNEL	FREQUENCY	CHANNEL	FREQUENCY
1	2412MHz	7	2442MHz
2	2417MHz	8	2447MHz
3	2422MHz	9	2452MHz
4	2427MHz	10	2457MHz
5	2432MHz	11	2462MHz
6	2437MHz		

Seven channels are provided for draft 802.11n (40MHz):

CHANNEL	FREQUENCY	CHANNEL	FREQUENCY
1	2422MHz	5	2442MHz
2	2427MHz	6	2447MHz
3	2432MHz	7	2452MHz
4	2437MHz		

#### 3.2.1 CONFIGURATION OF SYSTEM UNDER TEST

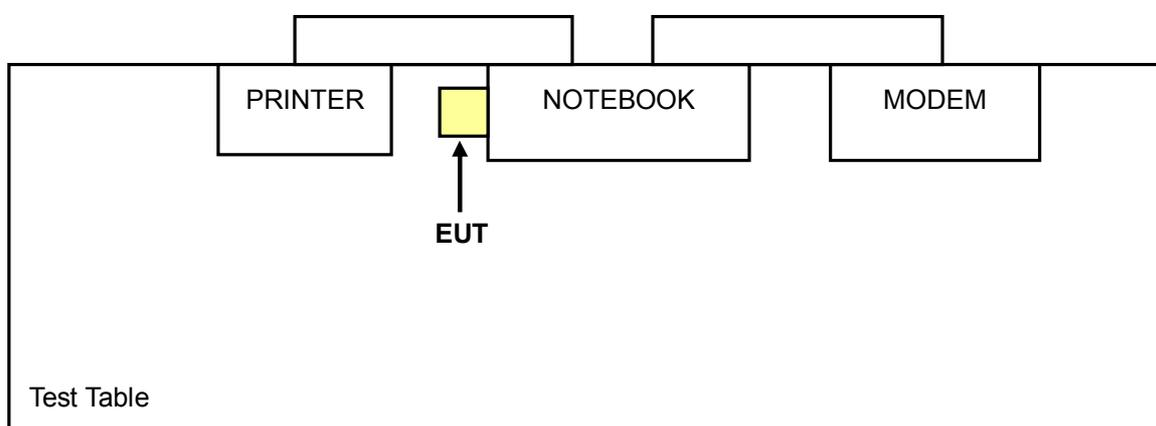

### 3.2.2 TEST MODE APPLICABILITY AND TESTED CHANNEL DETAIL

EUT CONFIGURE MODE	APPLICABLE TO				DESCRIPTION
	PLC	RE < 1G	RE ≥ 1G	OP	
-	√	√	√	√	-

Where **PLC**: Power Line Conducted Emission      **RE < 1G**: Radiated Emission below 1GHz  
**RE ≥ 1G**: Radiated Emission above 1GHz      **OP**: Maximum Peak Output Power

#### **POWER LINE CONDUCTED EMISSION TEST:**

- Pre-Scan has been conducted to determine the worst-case mode from all possible combinations between available modulations, data rates and antenna ports (if EUT with antenna diversity architecture).
- Following channel(s) was (were) selected for the final test as listed below.

MODE	AVAILABLE CHANNEL	TESTED CHANNEL	MODULATION TECHNOLOGY	MODULATION TYPE	DATA RATE (Mbps)	TX CONDITION
802.11g	1 to 11	1, 6, 11	OFDM	BPSK	6	Single
Draft 802.11n (20MHz)	1 to 11	1, 6, 11	OFDM	BPSK	14.444	Dual
Draft 802.11n (40MHz)	1 to 7	1, 4, 7	OFDM	BPSK	30	Dual

#### **RADIATED EMISSION TEST (BELOW 1 GHz):**

- Pre-Scan has been conducted to determine the worst-case mode from all possible combinations between available modulations, data rates and antenna ports (if EUT with antenna diversity architecture).
- Following channel(s) was (were) selected for the final test as listed below.

MODE	AVAILABLE CHANNEL	TESTED CHANNEL	MODULATION TECHNOLOGY	MODULATION TYPE	DATA RATE (Mbps)	TX CONDITION
802.11g	1 to 11	1	OFDM	BPSK	6	Single
Draft 802.11n (20MHz)	1 to 11	1	OFDM	BPSK	14.444	Dual
Draft 802.11n (40MHz)	1 to 7	1	OFDM	BPSK	30	Dual

**RADIATED EMISSION TEST (ABOVE 1 GHz):**

- Pre-Scan has been conducted to determine the worst-case mode from all possible combinations between available modulations, data rates and antenna ports (if EUT with antenna diversity architecture).
- Following channel(s) was (were) selected for the final test as listed below.

MODE	AVAILABLE CHANNEL	TESTED CHANNEL	MODULATION TECHNOLOGY	MODULATION TYPE	DATA RATE (Mbps)	TX CONDITION
802.11b	1 to 11	1, 11	DSSS	DBPSK	1	Single
802.11g	1 to 11	1, 11	OFDM	BPSK	6	Single
Draft 802.11n (20MHz)	1 to 11	1, 11	OFDM	BPSK	7.2	Single
Draft 802.11n (20MHz)	1 to 11	1, 11	OFDM	BPSK	14.444	Dual
Draft 802.11n (40MHz)	1 to 7	1, 7	OFDM	BPSK	15	Single
Draft 802.11n (40MHz)	1 to 7	1, 7	OFDM	BPSK	30	Dual

**MAXIMUM PEAK OUTPUT POWER MEASUREMENT:**

- Pre-Scan has been conducted to determine the worst-case mode from all possible combinations between available modulations, data rates and antenna ports (if EUT with antenna diversity architecture).
- Following channel(s) was (were) selected for the final test as listed below.

MODE	AVAILABLE CHANNEL	TESTED CHANNEL	MODULATION TECHNOLOGY	MODULATION TYPE	DATA RATE (Mbps)	TX CONDITION
802.11b	1 to 11	1, 6, 11	DSSS	DBPSK	1	Single
802.11g	1 to 11	1, 6, 11	OFDM	BPSK	6	Single
Draft 802.11n (20MHz)	1 to 11	1, 6, 11	OFDM	BPSK	7.2	Single
Draft 802.11n (20MHz)	1 to 11	1, 6, 11	OFDM	BPSK	14.444	Dual
Draft 802.11n (40MHz)	1 to 7	1, 4, 7	OFDM	BPSK	15	Single
Draft 802.11n (40MHz)	1 to 7	1, 4, 7	OFDM	BPSK	30	Dual

### **3.3 GENERAL DESCRIPTION OF APPLIED STANDARDS**

The EUT is a RF product. According to the specifications of the manufacturer, it must comply with the requirements of the following standards:

**FCC Part 15, Subpart C. (15.247)**

**ANSI C63.4-2003**

All test items have been performed and recorded as per the above standards.

**NOTE:** The EUT is also considered as a kind of computer peripheral, because the connection to computer is necessary for typical use. It has been verified to comply with the requirements of FCC Part 15, Subpart B, Class B (DoC). The test report has been issued separately.

### 3.4 DESCRIPTION OF SUPPORT UNITS

The EUT has been tested as an independent unit together with other necessary accessories or support units. The following support units or accessories were used to form a representative test configuration during the tests.

NO.	PRODUCT	BRAND	MODEL NO.	SERIAL NO.	FCC ID
1	NOTEBOOK COMPUTER	DELL	PP05L	16484462992	E2K24CLNS
2	PRINTER	EPSON	LQ-300+	DCGY054147	FCC DoC Approved
3	MODEM	ACEEX	1414V/3	0401008269	IFAXDM1414

NO.	SIGNAL CABLE DESCRIPTION OF THE ABOVE SUPPORT UNITS
1	NA
2	1.2m shielded cable
3	1.2m shielded cable

**NOTE:** All power cords of the above support units are non shielded (1.8m).

## 4. TEST TYPES AND RESULTS

### 4.1 CONDUCTED EMISSION MEASUREMENT

#### 4.1.1 LIMITS OF CONDUCTED EMISSION MEASUREMENT

FREQUENCY OF EMISSION (MHz)	CONDUCTED LIMIT (dB $\mu$ V)	
	Quasi-peak	Average
0.15-0.5	66 to 56	56 to 46
0.5-5	56	46
5-30	60	50

- NOTE:**
1. The lower limit shall apply at the transition frequencies.
  2. The limit decreases in line with the logarithm of the frequency in the range of 0.15 to 0.50 MHz.
  3. All emanations from a class A/B digital device or system, including any network of conductors and apparatus connected thereto, shall not exceed the level of field strengths specified above.

#### 4.1.2 TEST INSTRUMENTS

DESCRIPTION & MANUFACTURER	MODEL NO.	SERIAL NO.	CALIBRATED UNTIL
Test Receiver ROHDE & SCHWARZ	ESCS30	100288	Sep. 25, 2007
RF signal cable Woken	5D-FB	Cable-HYCO3-01	Jan. 06, 2007
LISN ROHDE & SCHWARZ	ESH2-Z5	100100	Jan. 09, 2007
LISN ROHDE & SCHWARZ	ESH3-Z5	100311	Jan. 22, 2007
Software ADT	ADT_Cond_V3	NA	NA

- NOTE:**
1. The calibration interval of the above test instruments is 12 months and the calibrations are traceable to NML/ROC and NIST/USA.
  2. The test was performed in HwaYa Shielded Room 2.
  3. The VCCI Site Registration No. is C-2047.

#### 4.1.3 TEST PROCEDURES

- a. The EUT was placed 0.4 meters from the conducting wall of the shielded room with EUT being connected to the power mains through a line impedance stabilization network (LISN). Other support units were connected to the power mains through another LISN. The two LISNs provide 50 ohm/ 50uH of coupling impedance for the measuring instrument.
- b. Both lines of the power mains connected to the EUT were checked for maximum conducted interference.
- c. The frequency range from 150kHz to 30MHz was searched. Emission levels under (Limit - 20dB) was not recorded.

#### 4.1.4 DEVIATION FROM TEST STANDARD

No deviation

#### 4.1.5 TEST SETUP

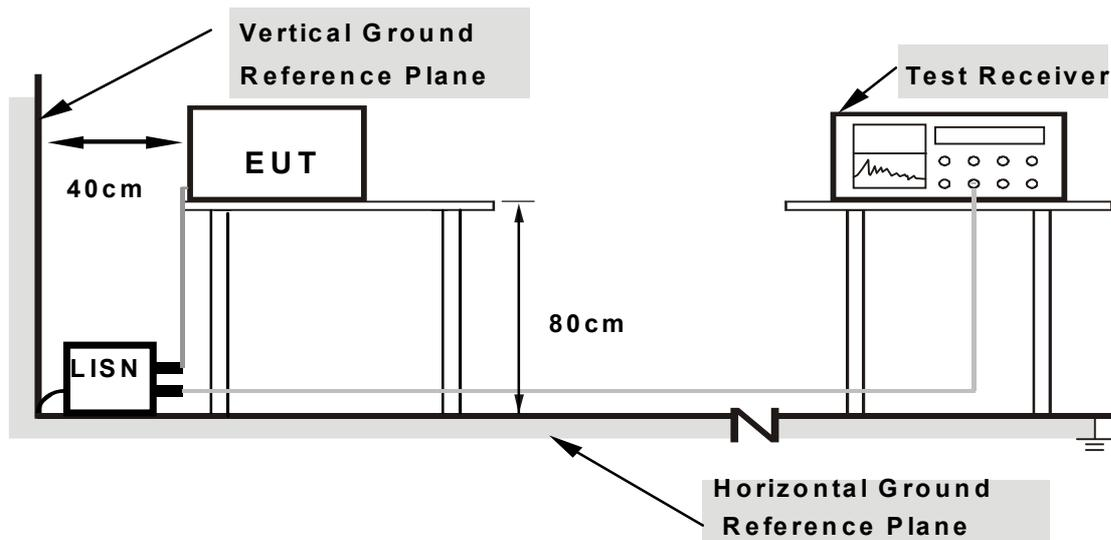

**Note: 1. Support units were connected to second LISN.**

**2. Both of LISNs (AMN) are 80 cm from EUT and at least 80 from other units and other metal planes**

For the actual test configuration, please refer to the related item – Photographs of the Test Configuration.

#### 4.1.6 EUT OPERATING CONDITIONS

- a. Connected the EUT into the notebook system and placed on a testing table.
- b. The computer system ran a test program (provided by manufacturer) to enable EUT under transmission/receiving condition continuously at specific channel frequency.
- c. The notebook system displayed “H” messages on its screen.
- d. The notebook system show “H” messages to modem.
- e. The notebook system sent "H" messages to printer and the printer prints them on paper.
- f. Repeated item c ~e.

#### 4.1.7 TEST RESULTS

##### CONDUCTED WORST-CASE DATA 802.11g OFDM MODULATION: SINGLE TX

EUT TEST CONDITION		MEASUREMENT DETAIL	
CHANNEL	Channel 1	PHASE	Line 1
MODULATION TYPE	BPSK	6dB BANDWIDTH	9 kHz
TRANSFER RATE	6Mbps	INPUT POWER (SYSTEM)	120Vac, 60 Hz
ENVIRONMENTAL CONDITIONS	20deg. C, 60%RH, 991hPa	TESTED BY	Match Tsui

No	Freq. [MHz]	Corr. Factor (dB)	Reading Value [dB (uV)]		Emission Level [dB (uV)]		Limit [dB (uV)]		Margin (dB)	
			Q.P.	AV.	Q.P.	AV.	Q.P.	AV.	Q.P.	AV.
1	0.220	0.10	43.73	-	43.83	-	62.81	52.81	-18.98	-
2	0.322	0.10	33.03	-	33.13	-	59.66	49.66	-26.53	-
3	0.416	0.10	25.25	-	25.35	-	57.52	47.52	-32.17	-
4	1.520	0.15	28.88	-	29.03	-	56.00	46.00	-26.97	-
5	10.238	0.37	29.87	-	30.24	-	60.00	50.00	-29.76	-
6	13.688	0.56	32.59	-	33.15	-	60.00	50.00	-26.85	-

- REMARKS:**
1. Q.P. and AV. are abbreviations of quasi-peak and average individually.
  2. "-": The Quasi-peak reading value also meets average limit and measurement with the average detector is unnecessary.
  3. The emission levels of other frequencies were very low against the limit.
  4. Margin value = Emission level - Limit value
  5. Correction factor = Insertion loss + Cable loss
  6. Emission Level = Correction Factor + Reading Value.

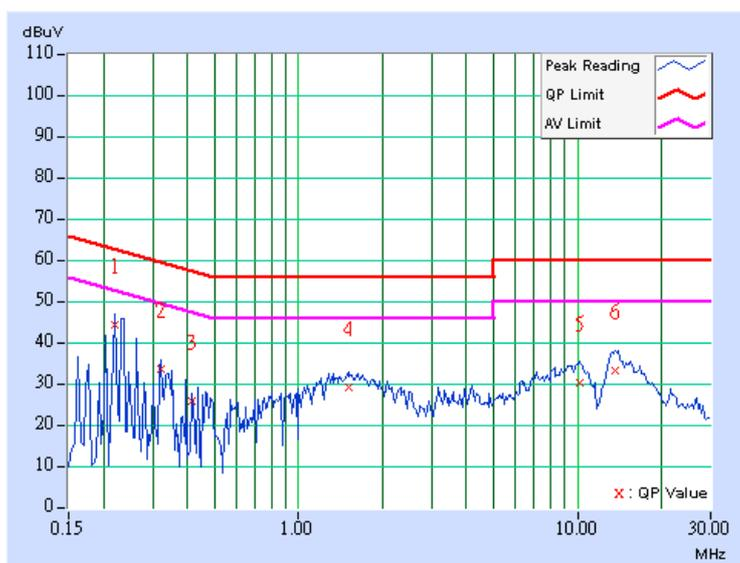

EUT TEST CONDITION		MEASUREMENT DETAIL	
CHANNEL	Channel 1	PHASE	Line 2
MODULATION TYPE	BPSK	6dB BANDWIDTH	9 kHz
TRANSFER RATE	6Mbps	INPUT POWER (SYSTEM)	120Vac, 60 Hz
ENVIRONMENTAL CONDITIONS	20deg. C, 60%RH, 991hPa	TESTED BY	Match Tsui

No	Freq. [MHz]	Corr. Factor (dB)	Reading Value [dB (uV)]		Emission Level [dB (uV)]		Limit [dB (uV)]		Margin (dB)	
			Q.P.	AV.	Q.P.	AV.	Q.P.	AV.	Q.P.	AV.
1	0.223	0.10	42.35	-	42.45	-	62.70	52.70	-20.25	-
2	0.345	0.10	31.66	-	31.76	-	59.07	49.07	-27.31	-
3	0.455	0.11	28.23	-	28.34	-	56.79	46.79	-28.45	-
4	1.289	0.20	25.70	-	25.90	-	56.00	46.00	-30.10	-
5	9.863	0.46	29.85	-	30.31	-	60.00	50.00	-29.69	-
6	13.496	0.58	31.99	-	32.57	-	60.00	50.00	-27.43	-

- REMARKS:**
1. Q.P. and AV. are abbreviations of quasi-peak and average individually.
  2. "-": The Quasi-peak reading value also meets average limit and measurement with the average detector is unnecessary.
  3. The emission levels of other frequencies were very low against the limit.
  4. Margin value = Emission level - Limit value
  5. Correction factor = Insertion loss + Cable loss
  6. Emission Level = Correction Factor + Reading Value.

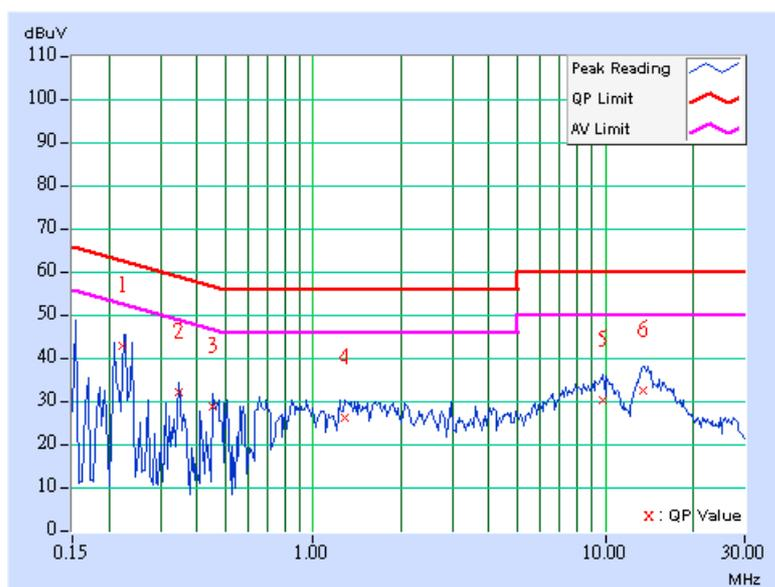

EUT TEST CONDITION		MEASUREMENT DETAIL	
CHANNEL	Channel 6	PHASE	Line 1
MODULATION TYPE	BPSK	6dB BANDWIDTH	9 kHz
TRANSFER RATE	6Mbps	INPUT POWER (SYSTEM)	120Vac, 60 Hz
ENVIRONMENTAL CONDITIONS	20deg. C, 60%RH, 991hPa	TESTED BY	Match Tsui

No	Freq. [MHz]	Corr. Factor (dB)	Reading Value [dB (uV)]		Emission Level [dB (uV)]		Limit [dB (uV)]		Margin (dB)	
			Q.P.	AV.	Q.P.	AV.	Q.P.	AV.	Q.P.	AV.
1	0.232	0.10	43.15	-	43.25	-	62.38	52.38	-19.13	-
2	0.353	0.10	30.39	-	30.49	-	58.89	48.89	-28.40	-
3	0.449	0.10	23.38	-	23.48	-	56.89	46.89	-33.41	-
4	1.398	0.14	29.47	-	29.61	-	56.00	46.00	-26.39	-
5	9.992	0.36	30.23	-	30.59	-	60.00	50.00	-29.41	-
6	13.805	0.57	32.78	-	33.35	-	60.00	50.00	-26.65	-

- REMARKS:**
1. Q.P. and AV. are abbreviations of quasi-peak and average individually.
  2. "-": The Quasi-peak reading value also meets average limit and measurement with the average detector is unnecessary.
  3. The emission levels of other frequencies were very low against the limit.
  4. Margin value = Emission level - Limit value
  5. Correction factor = Insertion loss + Cable loss
  6. Emission Level = Correction Factor + Reading Value.

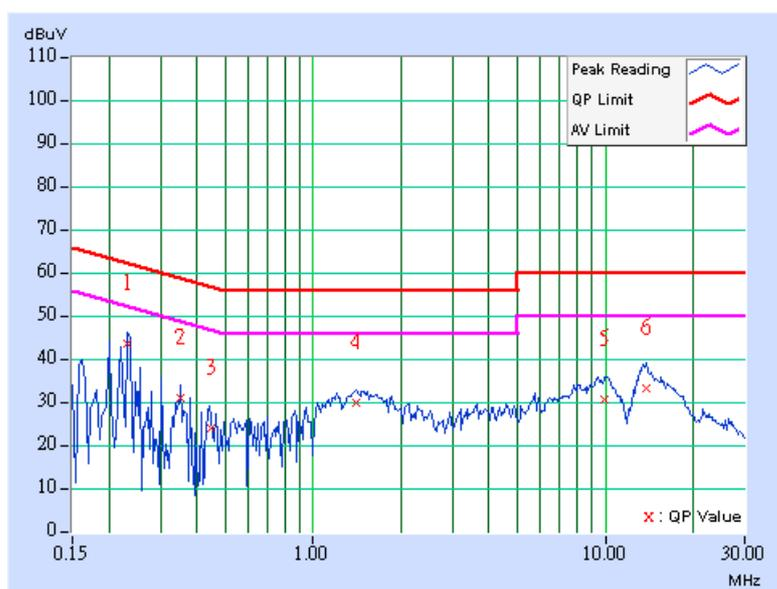

EUT TEST CONDITION		MEASUREMENT DETAIL	
CHANNEL	Channel 6	PHASE	Line 2
MODULATION TYPE	BPSK	6dB BANDWIDTH	9 kHz
TRANSFER RATE	6Mbps	INPUT POWER (SYSTEM)	120Vac, 60 Hz
ENVIRONMENTAL CONDITIONS	20deg. C, 60%RH, 991hPa	TESTED BY	Match Tsui

No	Freq. [MHz]	Corr. Factor (dB)	Reading Value [dB (uV)]		Emission Level [dB (uV)]		Limit [dB (uV)]		Margin (dB)	
			Q.P.	AV.	Q.P.	AV.	Q.P.	AV.	Q.P.	AV.
1	0.228	0.10	43.37	-	43.47	-	62.52	52.52	-19.05	-
2	0.291	0.10	31.50	-	31.60	-	60.51	50.51	-28.91	-
3	0.427	0.10	25.63	-	25.73	-	57.30	47.30	-31.57	-
4	1.418	0.20	24.10	-	24.30	-	56.00	46.00	-31.70	-
5	9.816	0.46	30.03	-	30.49	-	60.00	50.00	-29.51	-
6	13.469	0.58	32.44	-	33.02	-	60.00	50.00	-26.98	-

- REMARKS:**
1. Q.P. and AV. are abbreviations of quasi-peak and average individually.
  2. "-": The Quasi-peak reading value also meets average limit and measurement with the average detector is unnecessary.
  3. The emission levels of other frequencies were very low against the limit.
  4. Margin value = Emission level - Limit value
  5. Correction factor = Insertion loss + Cable loss
  6. Emission Level = Correction Factor + Reading Value.

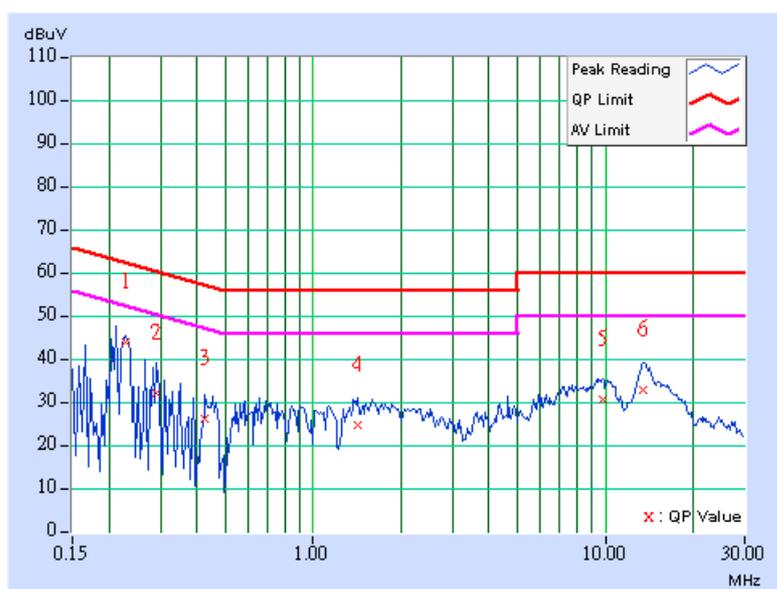

EUT TEST CONDITION		MEASUREMENT DETAIL	
CHANNEL	Channel 11	PHASE	Line 1
MODULATION TYPE	BPSK	6dB BANDWIDTH	9 kHz
TRANSFER RATE	6Mbps	INPUT POWER (SYSTEM)	120Vac, 60 Hz
ENVIRONMENTAL CONDITIONS	20deg. C, 60%RH, 991hPa	TESTED BY	Match Tsui

No	Freq. [MHz]	Corr. Factor (dB)	Reading Value [dB (uV)]		Emission Level [dB (uV)]		Limit [dB (uV)]		Margin (dB)	
			Q.P.	AV.	Q.P.	AV.	Q.P.	AV.	Q.P.	AV.
1	0.224	0.10	43.08	-	43.18	-	62.66	52.66	-19.48	-
2	0.318	0.10	28.73	-	28.83	-	59.76	49.76	-30.93	-
3	0.541	0.10	23.51	-	23.61	-	56.00	46.00	-32.39	-
4	1.477	0.15	29.37	-	29.52	-	56.00	46.00	-26.48	-
5	9.941	0.36	30.39	-	30.75	-	60.00	50.00	-29.25	-
6	13.855	0.57	33.18	-	33.75	-	60.00	50.00	-26.25	-

- REMARKS:**
1. Q.P. and AV. are abbreviations of quasi-peak and average individually.
  2. "-": The Quasi-peak reading value also meets average limit and measurement with the average detector is unnecessary.
  3. The emission levels of other frequencies were very low against the limit.
  4. Margin value = Emission level - Limit value
  5. Correction factor = Insertion loss + Cable loss
  6. Emission Level = Correction Factor + Reading Value.

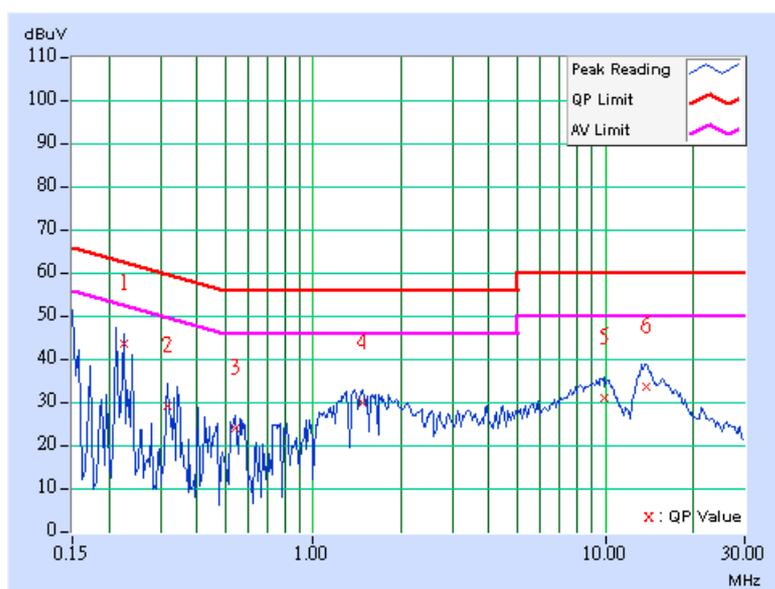

EUT TEST CONDITION		MEASUREMENT DETAIL	
CHANNEL	Channel 11	PHASE	Line 2
MODULATION TYPE	BPSK	6dB BANDWIDTH	9 kHz
TRANSFER RATE	6Mbps	INPUT POWER (SYSTEM)	120Vac, 60 Hz
ENVIRONMENTAL CONDITIONS	20deg. C, 60%RH, 991hPa	TESTED BY	Match Tsui

No	Freq. [MHz]	Corr. Factor (dB)	Reading Value [dB (uV)]		Emission Level [dB (uV)]		Limit [dB (uV)]		Margin (dB)	
			Q.P.	AV.	Q.P.	AV.	Q.P.	AV.	Q.P.	AV.
1	0.228	0.10	43.04	-	43.14	-	62.52	52.52	-19.38	-
2	0.326	0.10	30.92	-	31.02	-	59.56	49.56	-28.54	-
3	0.455	0.11	27.92	-	28.03	-	56.79	46.79	-28.76	-
4	1.848	0.20	26.01	-	26.21	-	56.00	46.00	-29.79	-
5	10.297	0.47	29.93	-	30.40	-	60.00	50.00	-29.60	-
6	13.617	0.58	33.00	-	33.58	-	60.00	50.00	-26.42	-

- REMARKS:**
1. Q.P. and AV. are abbreviations of quasi-peak and average individually.
  2. "-": The Quasi-peak reading value also meets average limit and measurement with the average detector is unnecessary.
  3. The emission levels of other frequencies were very low against the limit.
  4. Margin value = Emission level - Limit value
  5. Correction factor = Insertion loss + Cable loss
  6. Emission Level = Correction Factor + Reading Value.

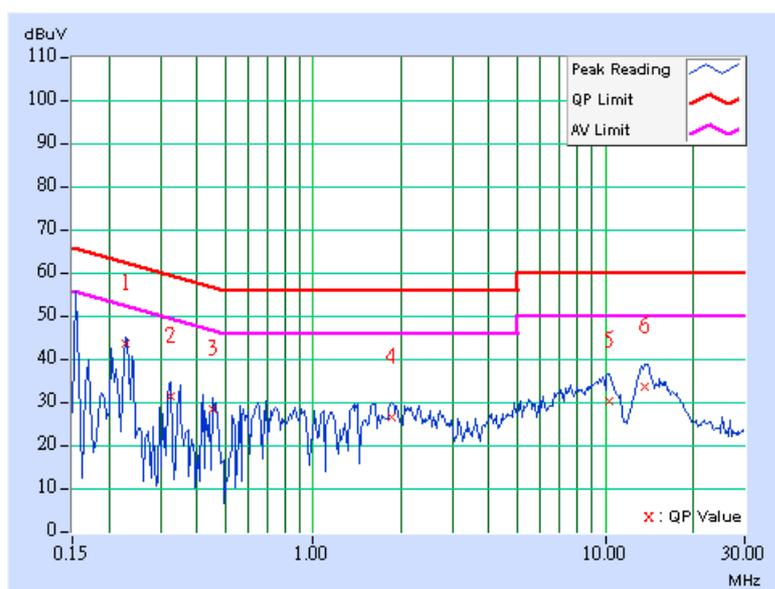

### DRAFT 802.11n (20MHz) OFDM MODULATION: DUAL TX

EUT TEST CONDITION		MEASUREMENT DETAIL	
CHANNEL	Channel 1	PHASE	Line 1
MODULATION TYPE	BPSK	6dB BANDWIDTH	9 kHz
TRANSFER RATE	14.444Mbps	INPUT POWER (SYSTEM)	120Vac, 60 Hz
ENVIRONMENTAL CONDITIONS	20deg. C, 60%RH, 991hPa	TESTED BY	Match Tsui

No	Freq. [MHz]	Corr. Factor (dB)	Reading Value [dB (uV)]		Emission Level [dB (uV)]		Limit [dB (uV)]		Margin (dB)	
			Q.P.	AV.	Q.P.	AV.	Q.P.	AV.	Q.P.	AV.
1	0.232	0.10	42.50	-	42.60	-	62.38	52.38	-19.78	-
2	0.279	0.10	27.79	-	27.89	-	60.85	50.85	-32.96	-
3	0.509	0.10	19.02	-	19.12	-	56.00	46.00	-36.88	-
4	1.629	0.16	29.59	-	29.75	-	56.00	46.00	-26.25	-
5	9.797	0.36	30.60	-	30.96	-	60.00	50.00	-29.04	-
6	13.914	0.57	33.28	-	33.85	-	60.00	50.00	-26.15	-

- REMARKS:**
1. Q.P. and AV. are abbreviations of quasi-peak and average individually.
  2. "-": The Quasi-peak reading value also meets average limit and measurement with the average detector is unnecessary.
  3. The emission levels of other frequencies were very low against the limit.
  4. Margin value = Emission level - Limit value
  5. Correction factor = Insertion loss + Cable loss
  6. Emission Level = Correction Factor + Reading Value.

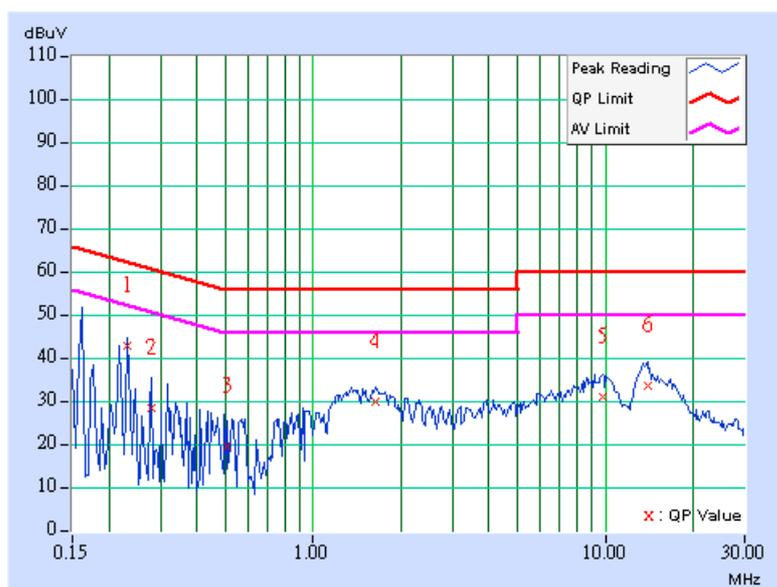

EUT TEST CONDITION		MEASUREMENT DETAIL	
CHANNEL	Channel 1	PHASE	Line 2
MODULATION TYPE	BPSK	6dB BANDWIDTH	9 kHz
TRANSFER RATE	14.444Mbps	INPUT POWER (SYSTEM)	120Vac, 60 Hz
ENVIRONMENTAL CONDITIONS	20deg. C, 60%RH, 991hPa	TESTED BY	Match Tsui

No	Freq. [MHz]	Corr. Factor (dB)	Reading Value [dB (uV)]		Emission Level [dB (uV)]		Limit [dB (uV)]		Margin (dB)	
			Q.P.	AV.	Q.P.	AV.	Q.P.	AV.	Q.P.	AV.
1	0.216	0.10	36.97	-	37.07	-	62.96	52.96	-25.89	-
2	0.338	0.10	30.00	-	30.10	-	59.26	49.26	-29.16	-
3	0.466	0.11	28.07	-	28.18	-	56.58	46.58	-28.40	-
4	1.629	0.20	27.31	-	27.51	-	56.00	46.00	-28.49	-
5	10.316	0.47	30.40	-	30.87	-	60.00	50.00	-29.13	-
6	13.867	0.59	32.96	-	33.55	-	60.00	50.00	-26.45	-

- REMARKS:**
1. Q.P. and AV. are abbreviations of quasi-peak and average individually.
  2. "-": The Quasi-peak reading value also meets average limit and measurement with the average detector is unnecessary.
  3. The emission levels of other frequencies were very low against the limit.
  4. Margin value = Emission level - Limit value
  5. Correction factor = Insertion loss + Cable loss
  6. Emission Level = Correction Factor + Reading Value.

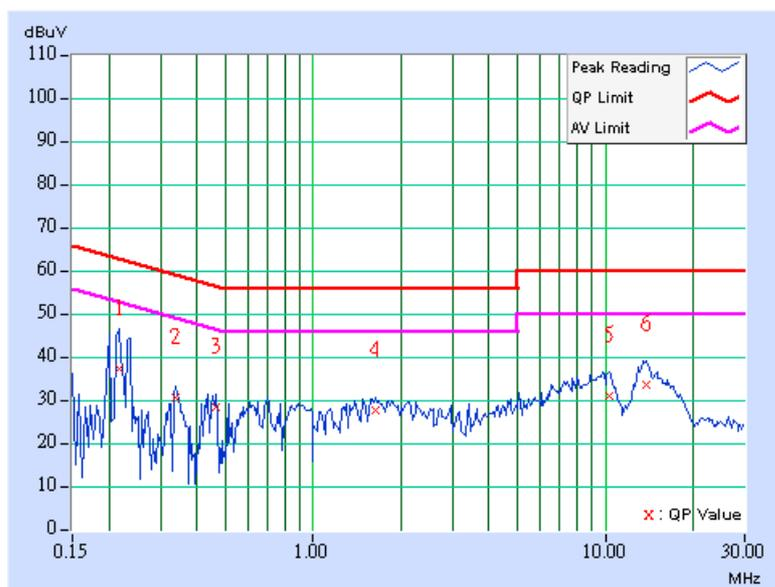

EUT TEST CONDITION		MEASUREMENT DETAIL	
CHANNEL	Channel 6	PHASE	Line 1
MODULATION TYPE	BPSK	6dB BANDWIDTH	9 kHz
TRANSFER RATE	14.444Mbps	INPUT POWER (SYSTEM)	120Vac, 60 Hz
ENVIRONMENTAL CONDITIONS	20deg. C, 60%RH, 991hPa	TESTED BY	Match Tsui

No	Freq. [MHz]	Corr. Factor (dB)	Reading Value [dB (uV)]		Emission Level [dB (uV)]		Limit [dB (uV)]		Margin (dB)	
			Q.P.	AV.	Q.P.	AV.	Q.P.	AV.	Q.P.	AV.
1	0.216	0.10	41.44	-	41.54	-	62.96	52.96	-21.42	-
2	0.338	0.10	30.73	-	30.83	-	59.26	49.26	-28.43	-
3	0.451	0.10	25.04	-	25.14	-	56.86	46.86	-31.72	-
4	1.641	0.16	29.71	-	29.87	-	56.00	46.00	-26.13	-
5	10.176	0.37	30.82	-	31.19	-	60.00	50.00	-28.81	-
6	13.980	0.57	32.92	-	33.49	-	60.00	50.00	-26.51	-

- REMARKS:**
1. Q.P. and AV. are abbreviations of quasi-peak and average individually.
  2. "-": The Quasi-peak reading value also meets average limit and measurement with the average detector is unnecessary.
  3. The emission levels of other frequencies were very low against the limit.
  4. Margin value = Emission level - Limit value
  5. Correction factor = Insertion loss + Cable loss
  6. Emission Level = Correction Factor + Reading Value.

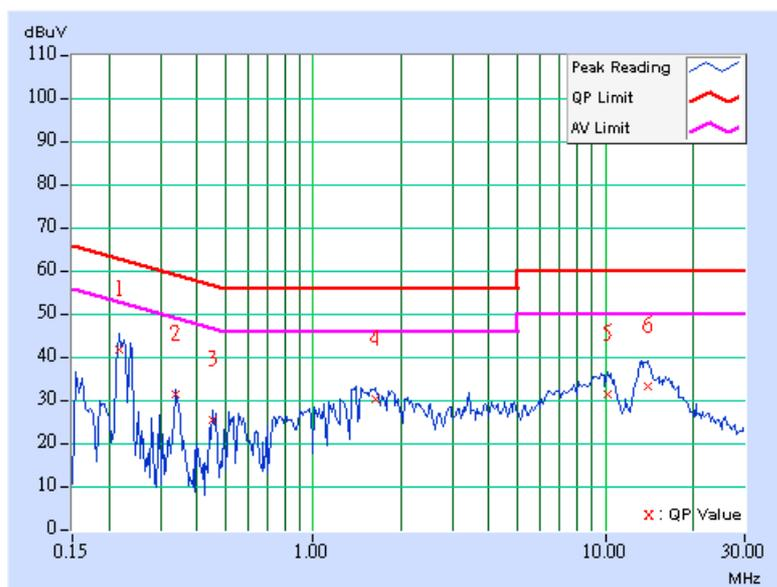

EUT TEST CONDITION		MEASUREMENT DETAIL	
CHANNEL	Channel 6	PHASE	Line 2
MODULATION TYPE	BPSK	6dB BANDWIDTH	9 kHz
TRANSFER RATE	14.444Mbps	INPUT POWER (SYSTEM)	120Vac, 60 Hz
ENVIRONMENTAL CONDITIONS	20deg. C, 60%RH, 991hPa	TESTED BY	Match Tsui

No	Freq. [MHz]	Corr. Factor (dB)	Reading Value [dB (uV)]		Emission Level [dB (uV)]		Limit [dB (uV)]		Margin (dB)	
			Q.P.	AV.	Q.P.	AV.	Q.P.	AV.	Q.P.	AV.
			1	0.228	0.10	42.47	-	42.57	-	62.52
2	0.334	0.10	28.22	-	28.32	-	59.36	49.36	-31.04	-
3	0.463	0.11	27.83	-	27.94	-	56.65	46.65	-28.71	-
4	1.770	0.20	22.23	-	22.43	-	56.00	46.00	-33.57	-
5	9.816	0.46	30.44	-	30.90	-	60.00	50.00	-29.10	-
6	13.398	0.58	32.50	-	33.08	-	60.00	50.00	-26.92	-

- REMARKS:**
1. Q.P. and AV. are abbreviations of quasi-peak and average individually.
  2. "-": The Quasi-peak reading value also meets average limit and measurement with the average detector is unnecessary.
  3. The emission levels of other frequencies were very low against the limit.
  4. Margin value = Emission level - Limit value
  5. Correction factor = Insertion loss + Cable loss
  6. Emission Level = Correction Factor + Reading Value.

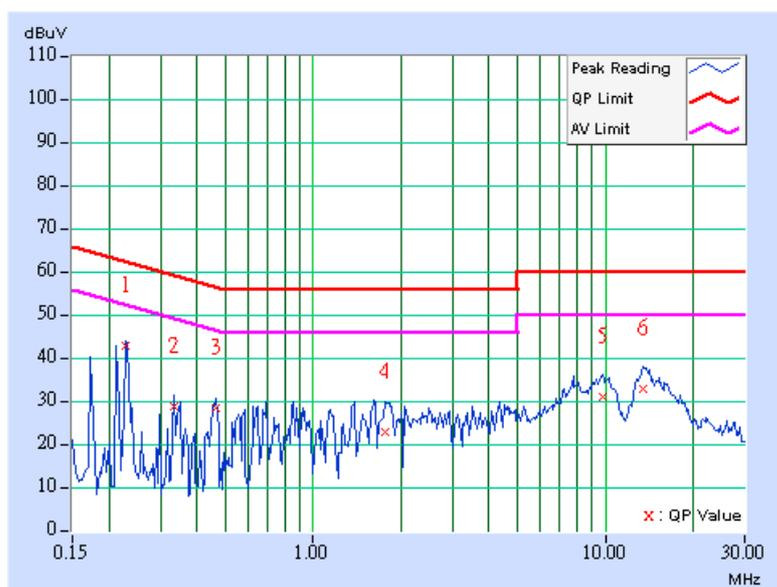

EUT TEST CONDITION		MEASUREMENT DETAIL	
CHANNEL	Channel 11	PHASE	Line 1
MODULATION TYPE	BPSK	6dB BANDWIDTH	9 kHz
TRANSFER RATE	14.444Mbps	INPUT POWER (SYSTEM)	120Vac, 60 Hz
ENVIRONMENTAL CONDITIONS	20deg. C, 60%RH, 991hPa	TESTED BY	Match Tsui

No	Freq. [MHz]	Corr. Factor (dB)	Reading Value [dB (uV)]		Emission Level [dB (uV)]		Limit [dB (uV)]		Margin (dB)	
			Q.P.	AV.	Q.P.	AV.	Q.P.	AV.	Q.P.	AV.
1	0.228	0.10	42.33	-	42.43	-	62.52	52.52	-20.09	-
2	0.338	0.10	30.89	-	30.99	-	59.26	49.26	-28.27	-
3	0.537	0.10	22.32	-	22.42	-	56.00	46.00	-33.58	-
4	1.469	0.15	29.37	-	29.52	-	56.00	46.00	-26.48	-
5	9.863	0.36	30.75	-	31.11	-	60.00	50.00	-28.89	-
6	13.918	0.57	33.20	-	33.77	-	60.00	50.00	-26.23	-

- REMARKS:**
1. Q.P. and AV. are abbreviations of quasi-peak and average individually.
  2. "-": The Quasi-peak reading value also meets average limit and measurement with the average detector is unnecessary.
  3. The emission levels of other frequencies were very low against the limit.
  4. Margin value = Emission level - Limit value
  5. Correction factor = Insertion loss + Cable loss
  6. Emission Level = Correction Factor + Reading Value.

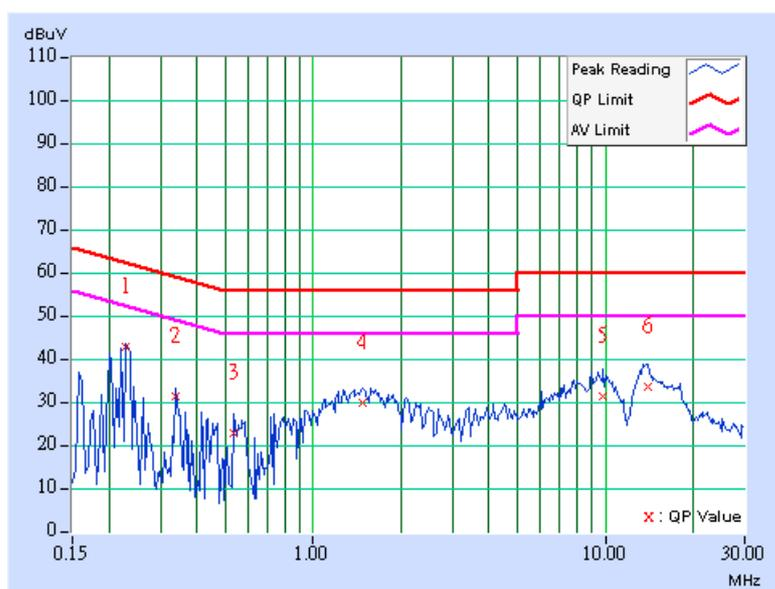

EUT TEST CONDITION		MEASUREMENT DETAIL	
CHANNEL	Channel 11	PHASE	Line 2
MODULATION TYPE	BPSK	6dB BANDWIDTH	9 kHz
TRANSFER RATE	14.444Mbps	INPUT POWER (SYSTEM)	120Vac, 60 Hz
ENVIRONMENTAL CONDITIONS	20deg. C, 60%RH, 991hPa	TESTED BY	Match Tsui

No	Freq. [MHz]	Corr. Factor (dB)	Reading Value [dB (uV)]		Emission Level [dB (uV)]		Limit [dB (uV)]		Margin (dB)	
			Q.P.	AV.	Q.P.	AV.	Q.P.	AV.	Q.P.	AV.
1	0.213	0.10	43.73	-	43.83	-	63.11	53.11	-19.28	-
2	0.345	0.10	30.18	-	30.28	-	59.07	49.07	-28.79	-
3	0.439	0.11	24.90	-	25.01	-	57.08	47.08	-32.07	-
4	1.617	0.20	26.91	-	27.11	-	56.00	46.00	-28.89	-
5	10.168	0.47	30.63	-	31.10	-	60.00	50.00	-28.90	-
6	13.551	0.58	32.88	-	33.46	-	60.00	50.00	-26.54	-

- REMARKS:**
1. Q.P. and AV. are abbreviations of quasi-peak and average individually.
  2. "-": The Quasi-peak reading value also meets average limit and measurement with the average detector is unnecessary.
  3. The emission levels of other frequencies were very low against the limit.
  4. Margin value = Emission level - Limit value
  5. Correction factor = Insertion loss + Cable loss
  6. Emission Level = Correction Factor + Reading Value.

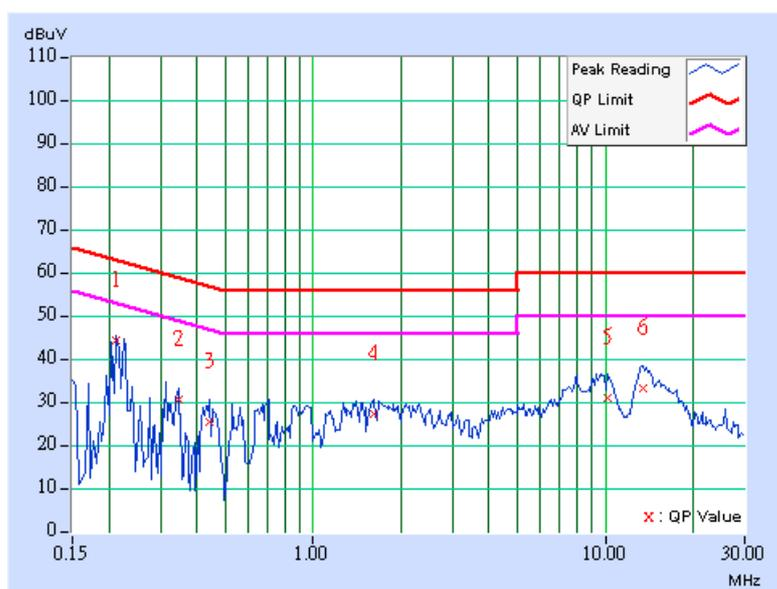

### DRAFT 802.11n (40MHz) OFDM MODULATION: DUAL TX

EUT TEST CONDITION		MEASUREMENT DETAIL	
CHANNEL	Channel 1	PHASE	Line 1
MODULATION TYPE	BPSK	6dB BANDWIDTH	9 kHz
TRANSFER RATE	30Mbps	INPUT POWER (SYSTEM)	120Vac, 60 Hz
ENVIRONMENTAL CONDITIONS	20deg. C, 60%RH, 991hPa	TESTED BY	Match Tsui

No	Freq. [MHz]	Corr. Factor (dB)	Reading Value [dB (uV)]		Emission Level [dB (uV)]		Limit [dB (uV)]		Margin (dB)	
			Q.P.	AV.	Q.P.	AV.	Q.P.	AV.	Q.P.	AV.
			1	0.220	0.10	43.14	-	43.24	-	62.81
2	0.315	0.10	30.85	-	30.95	-	59.84	49.84	-28.89	-
3	0.416	0.10	23.94	-	24.04	-	57.54	47.54	-33.50	-
4	1.633	0.16	29.91	-	30.07	-	56.00	46.00	-25.93	-
5	10.051	0.36	30.80	-	31.16	-	60.00	50.00	-28.84	-
6	13.887	0.57	33.26	-	33.83	-	60.00	50.00	-26.17	-

- REMARKS:**
1. Q.P. and AV. are abbreviations of quasi-peak and average individually.
  2. "-": The Quasi-peak reading value also meets average limit and measurement with the average detector is unnecessary.
  3. The emission levels of other frequencies were very low against the limit.
  4. Margin value = Emission level - Limit value
  5. Correction factor = Insertion loss + Cable loss
  6. Emission Level = Correction Factor + Reading Value.

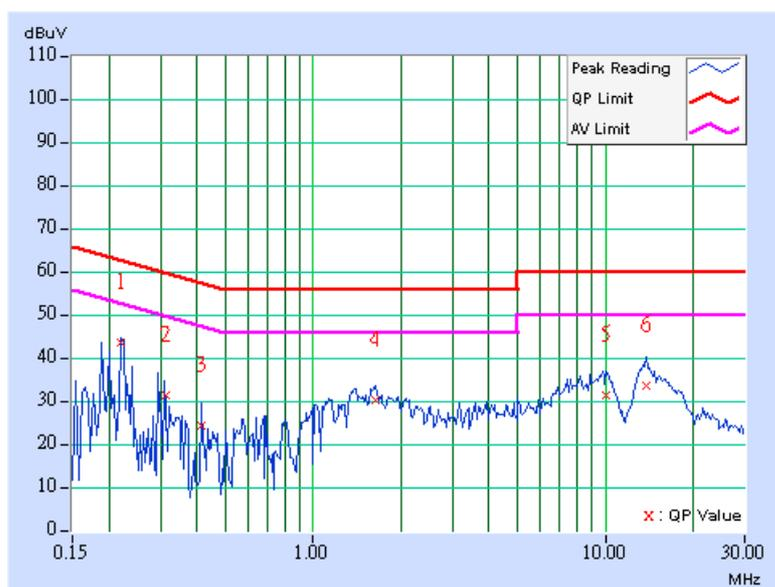

EUT TEST CONDITION		MEASUREMENT DETAIL	
CHANNEL	Channel 1	PHASE	Line 2
MODULATION TYPE	BPSK	6dB BANDWIDTH	9 kHz
TRANSFER RATE	30Mbps	INPUT POWER (SYSTEM)	120Vac, 60 Hz
ENVIRONMENTAL CONDITIONS	20deg. C, 60%RH, 991hPa	TESTED BY	Match Tsui

No	Freq. [MHz]	Corr. Factor (dB)	Reading Value [dB (uV)]		Emission Level [dB (uV)]		Limit [dB (uV)]		Margin (dB)	
			Q.P.	AV.	Q.P.	AV.	Q.P.	AV.	Q.P.	AV.
1	0.213	0.10	42.86	-	42.96	-	63.11	53.11	-20.15	-
2	0.322	0.10	31.30	-	31.40	-	59.66	49.66	-28.26	-
3	0.466	0.11	28.16	-	28.27	-	56.58	46.58	-28.31	-
4	1.816	0.20	26.82	-	27.02	-	56.00	46.00	-28.98	-
5	10.461	0.48	29.78	-	30.26	-	60.00	50.00	-29.74	-
6	13.648	0.58	33.14	-	33.72	-	60.00	50.00	-26.28	-

- REMARKS:**
1. Q.P. and AV. are abbreviations of quasi-peak and average individually.
  2. "-": The Quasi-peak reading value also meets average limit and measurement with the average detector is unnecessary.
  3. The emission levels of other frequencies were very low against the limit.
  4. Margin value = Emission level - Limit value
  5. Correction factor = Insertion loss + Cable loss
  6. Emission Level = Correction Factor + Reading Value.

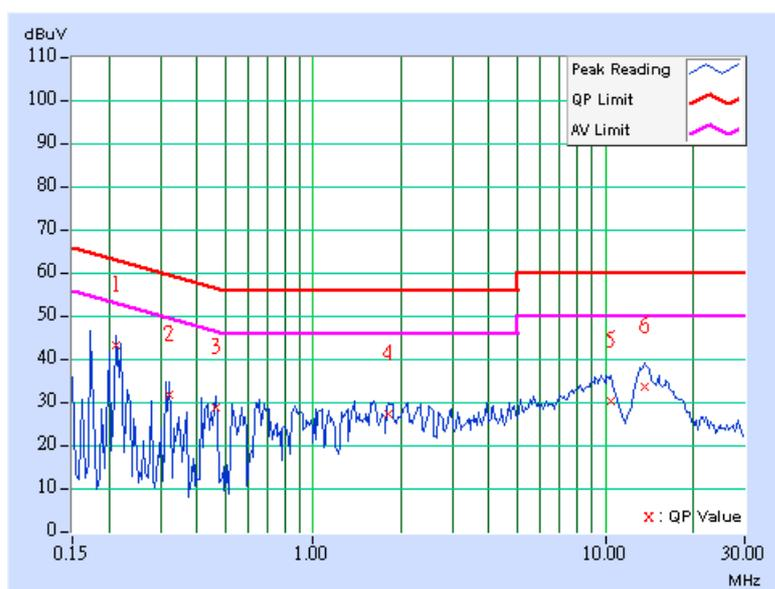

EUT TEST CONDITION		MEASUREMENT DETAIL	
CHANNEL	Channel 4	PHASE	Line 1
MODULATION TYPE	BPSK	6dB BANDWIDTH	9 kHz
TRANSFER RATE	30Mbps	INPUT POWER (SYSTEM)	120Vac, 60 Hz
ENVIRONMENTAL CONDITIONS	20deg. C, 60%RH, 991hPa	TESTED BY	Match Tsui

No	Freq. [MHz]	Corr. Factor (dB)	Reading Value [dB (uV)]		Emission Level [dB (uV)]		Limit [dB (uV)]		Margin (dB)	
			Q.P.	AV.	Q.P.	AV.	Q.P.	AV.	Q.P.	AV.
1	0.224	0.10	42.59	-	42.69	-	62.66	52.66	-19.97	-
2	0.338	0.10	30.49	-	30.59	-	59.26	49.26	-28.67	-
3	0.470	0.10	21.46	-	21.56	-	56.51	46.51	-34.95	-
4	1.414	0.14	27.63	-	27.77	-	56.00	46.00	-28.23	-
5	8.828	0.36	28.99	-	29.35	-	60.00	50.00	-30.65	-
6	13.984	0.58	33.04	-	33.62	-	60.00	50.00	-26.38	-

- REMARKS:**
1. Q.P. and AV. are abbreviations of quasi-peak and average individually.
  2. "-": The Quasi-peak reading value also meets average limit and measurement with the average detector is unnecessary.
  3. The emission levels of other frequencies were very low against the limit.
  4. Margin value = Emission level - Limit value
  5. Correction factor = Insertion loss + Cable loss
  6. Emission Level = Correction Factor + Reading Value.

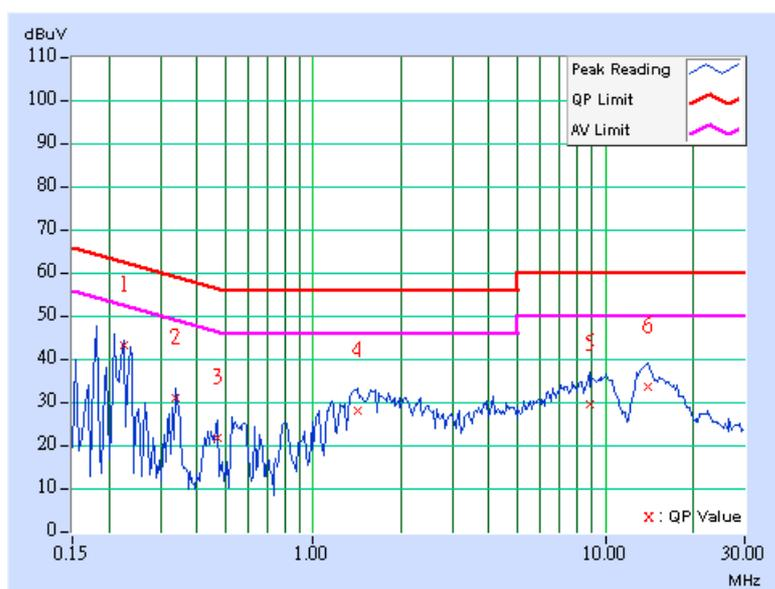

EUT TEST CONDITION		MEASUREMENT DETAIL	
CHANNEL	Channel 4	PHASE	Line 2
MODULATION TYPE	BPSK	6dB BANDWIDTH	9 kHz
TRANSFER RATE	30Mbps	INPUT POWER (SYSTEM)	120Vac, 60 Hz
ENVIRONMENTAL CONDITIONS	20deg. C, 60%RH, 991hPa	TESTED BY	Match Tsui

No	Freq. [MHz]	Corr. Factor (dB)	Reading Value [dB (uV)]		Emission Level [dB (uV)]		Limit [dB (uV)]		Margin (dB)	
			Q.P.	AV.	Q.P.	AV.	Q.P.	AV.	Q.P.	AV.
1	0.224	0.10	42.11	-	42.21	-	62.66	52.66	-20.45	-
2	0.345	0.10	30.64	-	30.74	-	59.07	49.07	-28.33	-
3	0.654	0.14	27.31	-	27.45	-	56.00	46.00	-28.55	-
4	1.633	0.20	27.57	-	27.77	-	56.00	46.00	-28.23	-
5	9.527	0.45	30.27	-	30.72	-	60.00	50.00	-29.28	-
6	13.402	0.58	32.71	-	33.29	-	60.00	50.00	-26.71	-

- REMARKS:**
1. Q.P. and AV. are abbreviations of quasi-peak and average individually.
  2. "-": The Quasi-peak reading value also meets average limit and measurement with the average detector is unnecessary.
  3. The emission levels of other frequencies were very low against the limit.
  4. Margin value = Emission level - Limit value
  5. Correction factor = Insertion loss + Cable loss
  6. Emission Level = Correction Factor + Reading Value.

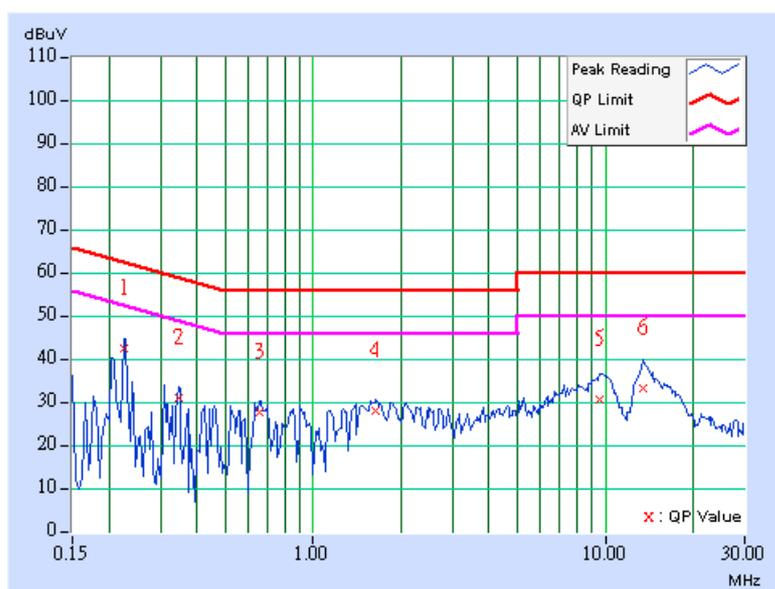

EUT TEST CONDITION		MEASUREMENT DETAIL	
CHANNEL	Channel 7	PHASE	Line 1
MODULATION TYPE	BPSK	6dB BANDWIDTH	9 kHz
TRANSFER RATE	30Mbps	INPUT POWER (SYSTEM)	120Vac, 60 Hz
ENVIRONMENTAL CONDITIONS	20deg. C, 60%RH, 991hPa	TESTED BY	Match Tsui

No	Freq. [MHz]	Corr. Factor (dB)	Reading Value [dB (uV)]		Emission Level [dB (uV)]		Limit [dB (uV)]		Margin (dB)	
			Q.P.	AV.	Q.P.	AV.	Q.P.	AV.	Q.P.	AV.
1	0.224	0.10	42.41	-	42.51	-	62.66	52.66	-20.15	-
2	0.341	0.10	29.96	-	30.06	-	59.17	49.17	-29.11	-
3	0.447	0.10	22.79	-	22.89	-	56.93	46.93	-34.04	-
4	1.473	0.15	28.14	-	28.29	-	56.00	46.00	-27.71	-
5	9.781	0.36	30.97	-	31.33	-	60.00	50.00	-28.67	-
6	13.906	0.57	33.43	-	34.00	-	60.00	50.00	-26.00	-

- REMARKS:**
1. Q.P. and AV. are abbreviations of quasi-peak and average individually.
  2. "-": The Quasi-peak reading value also meets average limit and measurement with the average detector is unnecessary.
  3. The emission levels of other frequencies were very low against the limit.
  4. Margin value = Emission level - Limit value
  5. Correction factor = Insertion loss + Cable loss
  6. Emission Level = Correction Factor + Reading Value.

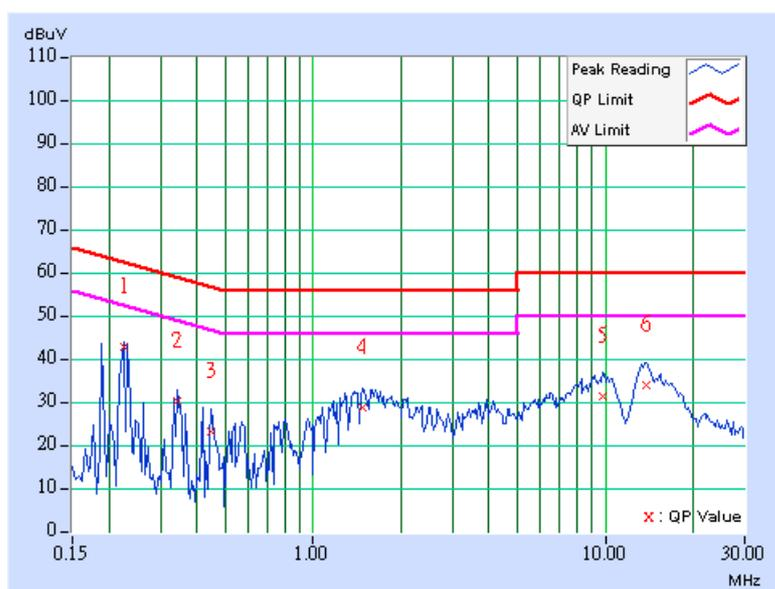

EUT TEST CONDITION		MEASUREMENT DETAIL	
CHANNEL	Channel 7	PHASE	Line 2
MODULATION TYPE	BPSK	6dB BANDWIDTH	9 kHz
TRANSFER RATE	30Mbps	INPUT POWER (SYSTEM)	120Vac, 60 Hz
ENVIRONMENTAL CONDITIONS	20deg. C, 60%RH, 991hPa	TESTED BY	Match Tsui

No	Freq. [MHz]	Corr. Factor (dB)	Reading Value [dB (uV)]		Emission Level [dB (uV)]		Limit [dB (uV)]		Margin (dB)	
			Q.P.	AV.	Q.P.	AV.	Q.P.	AV.	Q.P.	AV.
1	0.205	0.10	39.03	-	39.13	-	63.42	53.42	-24.29	-
2	0.233	0.10	42.99	-	43.09	-	62.36	52.36	-19.27	-
3	0.349	0.10	30.42	-	30.52	-	58.98	48.98	-28.46	-
4	1.641	0.20	27.03	-	27.23	-	56.00	46.00	-28.77	-
5	10.094	0.46	30.59	-	31.05	-	60.00	50.00	-28.95	-
6	13.773	0.59	33.18	-	33.77	-	60.00	50.00	-26.23	-

- REMARKS:**
1. Q.P. and AV. are abbreviations of quasi-peak and average individually.
  2. "-": The Quasi-peak reading value also meets average limit and measurement with the average detector is unnecessary.
  3. The emission levels of other frequencies were very low against the limit.
  4. Margin value = Emission level - Limit value
  5. Correction factor = Insertion loss + Cable loss
  6. Emission Level = Correction Factor + Reading Value.

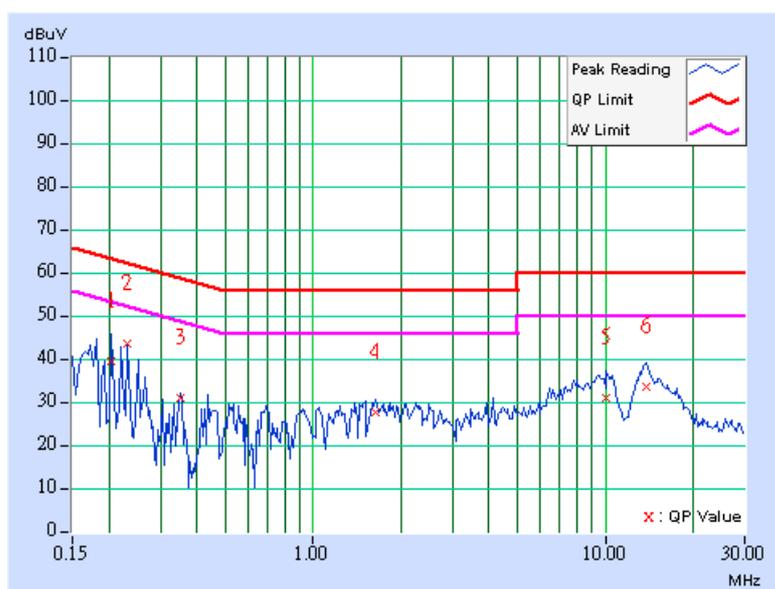

## 4.2 RADIATED EMISSION MEASUREMENT

### 4.2.1 LIMITS OF RADIATED EMISSION MEASUREMENT

Emissions radiated outside of the specified bands, shall be according to the general radiated limits in 15.209 as following:

FREQUENCIES (MHz)	FIELD STRENGTH (microvolts/meter)	MEASUREMENT DISTANCE (meters)
0.009 ~ 0.490	2400 / F(kHz)	300
0.490 ~ 1.705	24000 / F(kHz)	30
1.705 ~ 30.0	30	30
30 ~ 88	100	3
88 ~ 216	150	3
216 ~ 960	200	3
Above 960	500	3

**NOTE:**

1. The lower limit shall apply at the transition frequencies.
2. Emission level (dBuV/m) = 20 log Emission level (uV/m).
3. As shown in 15.35(b), for frequencies above 1000MHz, the field strength limits are based on average detector, however, the peak field strength of any emission shall not exceed the maximum permitted average limits, specified above by more than 20dB under any condition of modulation.

#### 4.2.2 TEST INSTRUMENTS

DESCRIPTION & MANUFACTURER	MODEL NO.	SERIAL NO.	CALIBRATED UNTIL
Test Receiver ROHDE & SCHWARZ	ESMI	839013/007 839379/002	Jan. 24, 2007
Spectrum Analyzer ROHDE & SCHWARZ	FSEK30	100049	Aug. 21, 2007
BILOG Antenna SCHWARZBECK	VULB9168	9168-153	Jan. 15, 2007
HORN Antenna SCHWARZBECK	BBHA 9120 D	9120D-407	Jan. 22, 2007
HORN Antenna SCHWARZBECK	BBHA 9170	BBHA9170242	Jan. 19, 2007
Preamplifier Agilent	8449B	3008A01911	Sep. 13, 2007
RF signal cable HUBER+SUHNNER	SUCOFLEX 104	218188/218189	Dec. 13, 2006
RF signal cable Worken	8D-FB	Cable-HYCH9-01	Mar. 08, 2007
Software ADT.	ADT_Radiated_ V7.6.01	NA	NA
Antenna Tower EMCO	2070/2080	512.835.4684	NA
Antenna Tower Controller EMCO	2090	NA	NA
Turn Table EMCO	2087-2.03	NA	NA
Turn Table Controller EMCO	2090	NA	NA

- NOTE:**
1. The calibration interval of the above test instruments is 12 months and the calibrations are traceable to NML/ROC and NIST/USA.
  2. The test was performed in HwaYa Chamber 9.
  3. The horn antenna and HP preamplifier (model: 8449B) are used only for the measurement of emission frequency above 1GHz if tested.
  4. The IC Site Registration No. is IC4924A-9.

#### 4.2.3 TEST PROCEDURES

- a. The EUT was placed on the top of a rotating table 0.8 meters above the ground at a 3 meters semi-anechoic chamber. The table was rotated 360 degrees to determine the position of the highest radiation.
- b. The EUT was set 3 meters away from the interference-receiving antenna, which was mounted on the top of a variable-height antenna tower.
- c. The antenna is a broadband antenna, and its height is varied from one meter to four meters above the ground to determine the maximum value of the field strength. Both horizontal and vertical polarizations of the antenna are set to make the measurement.
- d. For each suspected emission, the EUT was arranged to its worst case and then the antenna was tuned to heights from 1 meter to 4 meters and the rotatable table was turned from 0 degrees to 360 degrees to find the maximum reading.
- e. The test-receiver system was set to Peak Detect Function and Specified Bandwidth with Maximum Hold Mode.
- f. If the emission level of the EUT in peak mode was lower than the limit specified, then testing could be stopped and the peak values of the EUT would be reported. Otherwise the emissions would be re-tested one by one using peak, quasi-peak or average method as specified and then reported in a data sheet.

**NOTE:**

1. The resolution bandwidth and video bandwidth of test receiver/spectrum analyzer is 120kHz for Peak detection (PK) and Quasi-peak detection (QP) at frequency below 1GHz.
2. The resolution bandwidth of test receiver/spectrum analyzer is 1 MHz and video bandwidth is 3MHz for Peak detection at frequency above 1GHz.

#### 4.2.4 DEVIATION FROM TEST STANDARD

No deviation

#### 4.2.5 TEST SETUP

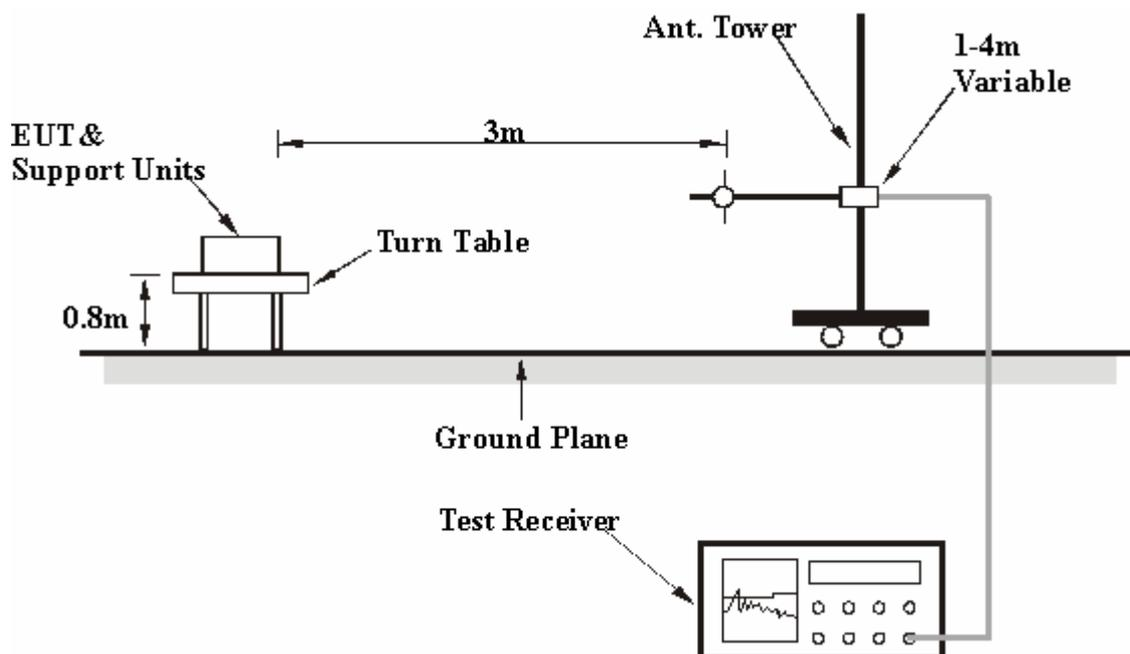

For the actual test configuration, please refer to the related item – Photographs of the Test Configuration.

#### 4.2.6 EUT OPERATING CONDITIONS

Same as 4.1.6

## 4.2.7 TEST RESULTS

### BELOW 1GHz WORST-CASE DATA 802.11g OFDM MODULATION: SINGLE TX

EUT TEST CONDITION		MEASUREMENT DETAIL	
CHANNEL	Channel 1	FREQUENCY RANGE	Below 1000MHz
MODULATION TYPE	BPSK for 802.11g	INPUT POWER (SYSTEM)	120Vac, 60 Hz
TRANSFER RATE	6Mbps	DETECTOR FUNCTION	Quasi-Peak
ENVIRONMENTAL CONDITIONS	25deg. C, 65%RH, 991hPa	TESTED BY	Lori Chui

ANTENNA POLARITY & TEST DISTANCE: HORIZONTAL AT 3 M								
No.	Freq. (MHz)	Emission Level (dBuV/m)	Limit (dBuV/m)	Margin (dB)	Antenna Height (m)	Table Angle (Degree)	Raw Value (dBuV)	Correction Factor (dB/m)
1	123.31	33.95 QP	43.50	-9.55	2.50 H	67	23.48	10.47
2	156.35	31.40 QP	43.50	-12.10	2.50 H	67	18.78	12.62
3	199.12	34.05 QP	43.50	-9.45	3.00 H	67	24.07	9.99
4	333.25	42.30 QP	46.00	-3.70	3.00 H	225	27.40	14.89
5	465.43	34.32 QP	46.00	-11.68	3.00 H	225	16.47	17.85

ANTENNA POLARITY & TEST DISTANCE: VERTICAL AT 3 M								
No.	Freq. (MHz)	Emission Level (dBuV/m)	Limit (dBuV/m)	Margin (dB)	Antenna Height (m)	Table Angle (Degree)	Raw Value (dBuV)	Correction Factor (dB/m)
1	43.61	26.31 QP	40.00	-13.69	1.00 V	29	11.95	14.36
2	74.71	28.04 QP	40.00	-11.96	1.00 V	73	17.22	10.82
3	123.31	36.60 QP	43.50	-6.90	1.00 V	149	26.13	10.47
4	164.13	31.24 QP	43.50	-12.26	1.00 V	54	18.92	12.32
5	199.12	30.57 QP	43.50	-12.93	1.00 V	130	20.58	9.99
6	331.30	36.99 QP	46.00	-9.01	1.00 V	130	22.12	14.87
7	383.79	31.79 QP	46.00	-14.21	1.50 V	73	15.64	16.15
8	465.43	30.08 QP	46.00	-15.92	1.00 V	99	12.23	17.85
9	591.78	30.19 QP	46.00	-15.81	1.00 V	333	9.58	20.61

- REMARKS:**
1. Emission level(dBuV/m)=Raw Value(dBuV) + Correction Factor(dB/m)
  2. Correction Factor(dB/m) = Antenna Factor (dB/m) + Cable Factor (dB)
  3. The other emission levels were very low against the limit.
  4. Margin value = Emission level – Limit value.

**DRAFT 802.11n (20MHz) OFDM MODULATION: DUAL TX**

EUT TEST CONDITION		MEASUREMENT DETAIL	
<b>CHANNEL</b>	Channel 1	<b>FREQUENCY RANGE</b>	Below 1000MHz
<b>MODULATION TYPE</b>	BPSK for draft 802.11n (20MHz)	<b>INPUT POWER (SYSTEM)</b>	120Vac, 60 Hz
<b>TRANSFER RATE</b>	14.444Mbps	<b>DETECTOR FUNCTION</b>	Quasi-Peak
<b>ENVIRONMENTAL CONDITIONS</b>	25deg. C, 65%RH, 991hPa	<b>TESTED BY</b>	Lori Chui

ANTENNA POLARITY & TEST DISTANCE: HORIZONTAL AT 3 M								
No.	Freq. (MHz)	Emission Level (dBuV/m)	Limit (dBuV/m)	Margin (dB)	Antenna Height (m)	Table Angle (Degree)	Raw Value (dBuV)	Correction Factor (dB/m)
1	74.71	26.64 QP	40.00	-13.36	1.50 H	54	15.83	10.82
2	121.36	34.38 QP	43.50	-9.12	1.50 H	80	24.16	10.22
3	158.30	30.66 QP	43.50	-12.84	1.50 H	92	18.05	12.61
4	199.12	34.47 QP	43.50	-9.03	2.00 H	200	24.49	9.99
5	333.25	42.95 QP	46.00	-3.05	1.00 H	168	28.05	14.89
6	360.46	32.14 QP	46.00	-13.86	1.00 H	23	16.72	15.42
7	467.37	35.48 QP	46.00	-10.52	2.00 H	92	17.59	17.89
8	799.78	32.18 QP	46.00	-13.82	1.00 H	118	8.20	23.98

ANTENNA POLARITY & TEST DISTANCE: VERTICAL AT 3 M								
No.	Freq. (MHz)	Emission Level (dBuV/m)	Limit (dBuV/m)	Margin (dB)	Antenna Height (m)	Table Angle (Degree)	Raw Value (dBuV)	Correction Factor (dB/m)
1	37.78	26.47 QP	40.00	-13.53	1.00 V	48	13.26	13.21
2	72.77	29.62 QP	40.00	-10.38	1.50 V	5	18.52	11.10
3	123.31	37.00 QP	43.50	-6.50	1.00 V	168	26.53	10.47
4	168.02	30.78 QP	43.50	-12.72	1.00 V	105	18.72	12.06
5	199.12	30.33 QP	43.50	-13.17	1.00 V	301	20.34	9.99
6	333.25	38.74 QP	46.00	-7.26	1.00 V	105	23.85	14.89
7	902.81	32.03 QP	46.00	-13.97	1.00 V	130	6.97	25.06

- REMARKS:**
1. Emission level(dBuV/m)=Raw Value(dBuV) + Correction Factor(dB/m)
  2. Correction Factor(dB/m) = Antenna Factor (dB/m) + Cable Factor (dB)
  3. The other emission levels were very low against the limit.
  4. Margin value = Emission level – Limit value.



**DRAFT 802.11n (40MHz) OFDM MODULATION: DUAL TX**

EUT TEST CONDITION		MEASUREMENT DETAIL	
CHANNEL	Channel 1	FREQUENCY RANGE	Below 1000MHz
MODULATION TYPE	BPSK for draft 802.11n (40MHz)	INPUT POWER (SYSTEM)	120Vac, 60 Hz
TRANSFER RATE	30Mbps	DETECTOR FUNCTION	Quasi-Peak
ENVIRONMENTAL CONDITIONS	25deg. C, 65%RH, 991hPa	TESTED BY	Lori Chui

ANTENNA POLARITY & TEST DISTANCE: HORIZONTAL AT 3 M								
No.	Freq. (MHz)	Emission Level (dBuV/m)	Limit (dBuV/m)	Margin (dB)	Antenna Height (m)	Table Angle (Degree)	Raw Value (dBuV)	Correction Factor (dB/m)
1	119.42	34.52 QP	43.50	-8.98	2.00 H	86	24.53	9.99
2	154.41	31.49 QP	43.50	-12.01	2.00 H	80	18.86	12.63
3	199.12	33.60 QP	43.50	-9.90	2.00 H	200	23.61	9.99
4	331.30	42.35 QP	46.00	-3.65	2.00 H	200	27.48	14.87
5	360.46	31.37 QP	46.00	-14.63	1.00 H	346	15.96	15.42
6	399.34	32.30 QP	46.00	-13.70	2.00 H	181	15.66	16.64
7	465.43	33.95 QP	46.00	-12.05	2.00 H	181	16.10	17.85
8	500.42	31.30 QP	46.00	-14.70	2.00 H	232	12.68	18.62
9	801.72	31.76 QP	46.00	-14.24	2.00 H	105	7.75	24.01

ANTENNA POLARITY & TEST DISTANCE: VERTICAL AT 3 M								
No.	Freq. (MHz)	Emission Level (dBuV/m)	Limit (dBuV/m)	Margin (dB)	Antenna Height (m)	Table Angle (Degree)	Raw Value (dBuV)	Correction Factor (dB/m)
1	72.77	29.52 QP	40.00	-10.48	1.00 V	86	18.41	11.10
2	121.36	35.07 QP	43.50	-8.43	1.00 V	168	24.85	10.22
3	134.97	34.63 QP	43.50	-8.87	1.50 V	111	22.61	12.02
4	162.18	29.77 QP	43.50	-13.73	1.00 V	137	17.32	12.45
5	199.12	30.31 QP	43.50	-13.19	1.50 V	137	20.32	9.99
6	333.25	38.82 QP	46.00	-7.18	1.50 V	111	23.93	14.89

- REMARKS:**
1. Emission level(dBuV/m)=Raw Value(dBuV) + Correction Factor(dB/m)
  2. Correction Factor(dB/m) = Antenna Factor (dB/m) + Cable Factor (dB)
  3. The other emission levels were very low against the limit.
  4. Margin value = Emission level – Limit value.

**802.11b DSSS MODULATION:**

EUT TEST CONDITION		MEASUREMENT DETAIL	
CHANNEL	Channel 1	FREQUENCY RANGE	1 ~ 25GHz
MODULATION TYPE	DBPSK	INPUT POWER (SYSTEM)	120Vac, 60 Hz
TRANSFER RATE	1Mbps	DETECTOR FUNCTION	Peak(PK) Average (AV)
ENVIRONMENTAL CONDITIONS	25deg. C, 65%RH, 991hPa	TESTED BY	Lori Chui

ANTENNA POLARITY & TEST DISTANCE: HORIZONTAL AT 3 M								
NO.	FREQ. (MHz)	EMISSION LEVEL (dBuV/m)	LIMIT (dBuV/m)	MARGIN (dB)	ANTENNA HEIGHT (m)	TABLE ANGLE (Degree)	RAW VALUE (dBuV)	CORRECTION FACTOR (dB/m)
1	2386.00	66.47 PK	74.00	-7.53	1.33 H	276	35.26	31.21
2	<b>2386.00</b>	<b>53.00 AV</b>	<b>54.00</b>	<b>-1.00</b>	<b>1.33 H</b>	<b>276</b>	<b>21.79</b>	<b>31.21</b>
3	*2412.00	105.39 PK			1.33 H	276	74.19	31.20
4	*2412.00	100.89 AV			1.33 H	276	69.69	31.20
5	4824.00	52.92 PK	74.00	-21.08	1.02 H	220	16.49	36.42
6	4824.00	49.65 AV	54.00	-4.35	1.02 H	220	13.22	36.42
7	7236.00	54.25 PK	74.00	-19.75	1.30 H	222	11.33	42.92
8	7236.00	41.79 AV	54.00	-12.21	1.30 H	222	-1.13	42.92

ANTENNA POLARITY & TEST DISTANCE: VERTICAL AT 3 M								
NO.	FREQ. (MHz)	EMISSION LEVEL (dBuV/m)	LIMIT (dBuV/m)	MARGIN (dB)	ANTENNA HEIGHT (m)	TABLE ANGLE (Degree)	RAW VALUE (dBuV)	CORRECTION FACTOR (dB/m)
1	2386.00	60.80 PK	74.00	-13.20	1.09 V	80	29.59	31.21
2	2386.00	50.89 AV	54.00	-3.11	1.09 V	80	19.68	31.21
3	*2412.00	102.04 PK			1.08 V	81	70.84	31.20
4	*2412.00	97.41 AV			1.08 V	81	66.21	31.20
5	4824.00	50.59 PK	74.00	-23.41	1.03 V	179	14.16	36.42
6	4824.00	45.96 AV	54.00	-8.04	1.03 V	179	9.53	36.42

- REMARKS:**
1. Emission level (dBuV/m) = Raw Value (dBuV) + Correction Factor (dB/m).
  2. Correction Factor (dB/m) = Antenna Factor (dB/m) + Cable Factor (dB).
  3. The other emission levels were very low against the limit.
  4. Margin value = Emission level – Limit value.
  5. “ \* “: Fundamental frequency.

EUT TEST CONDITION		MEASUREMENT DETAIL	
CHANNEL	Channel 11	FREQUENCY RANGE	1 ~ 25GHz
MODULATION TYPE	DBPSK	INPUT POWER (SYSTEM)	120Vac, 60 Hz
TRANSFER RATE	1Mbps	DETECTOR FUNCTION	Peak(PK) Average (AV)
ENVIRONMENTAL CONDITIONS	25deg. C, 65%RH, 991hPa	TESTED BY	Lori Chui

ANTENNA POLARITY & TEST DISTANCE: HORIZONTAL AT 3 M								
NO.	FREQ. (MHz)	EMISSION LEVEL (dBuV/m)	LIMIT (dBuV/m)	MARGIN (dB)	ANTENNA HEIGHT (m)	TABLE ANGLE (Degree)	RAW VALUE (dBuV)	CORRECTION FACTOR (dB/m)
1	*2462.00	106.46 PK			1.30 H	279	75.24	31.22
2	*2462.00	101.87 AV			1.30 H	279	70.65	31.22
3	2487.00	59.78 PK	74.00	-14.22	1.29 H	283	28.55	31.23
4	2487.00	51.27 AV	54.00	-2.73	1.29 H	283	20.04	31.23
5	4924.00	48.17 PK	74.00	-25.83	1.01 H	217	11.53	36.63
6	4924.00	41.55 AV	54.00	-12.45	1.01 H	217	4.91	36.63

ANTENNA POLARITY & TEST DISTANCE: VERTICAL AT 3 M								
NO.	FREQ. (MHz)	EMISSION LEVEL (dBuV/m)	LIMIT (dBuV/m)	MARGIN (dB)	ANTENNA HEIGHT (m)	TABLE ANGLE (Degree)	RAW VALUE (dBuV)	CORRECTION FACTOR (dB/m)
1	*2462.00	98.04 PK			1.00 V	220	66.82	31.22
2	*2462.00	93.38 AV			1.00 V	220	62.16	31.22
3	2487.00	58.04 PK	74.00	-15.96	1.00 V	221	26.81	31.23
4	2487.00	47.06 AV	54.00	-6.94	1.00 V	221	15.83	31.23
5	4924.00	46.39 PK	74.00	-27.61	1.00 V	357	9.75	36.63
6	4924.00	38.15 AV	54.00	-15.85	1.00 V	357	1.51	36.63

- REMARKS:**
1. Emission level (dBuV/m) = Raw Value (dBuV) + Correction Factor (dB/m).
  2. Correction Factor (dB/m) = Antenna Factor (dB/m) + Cable Factor (dB).
  3. The other emission levels were very low against the limit.
  4. Margin value = Emission level – Limit value.
  5. “ \* “: Fundamental frequency.

**802.11g OFDM MODULATION:**

EUT TEST CONDITION		MEASUREMENT DETAIL	
CHANNEL	Channel 1	FREQUENCY RANGE	1 ~ 25GHz
MODULATION TYPE	BPSK	INPUT POWER (SYSTEM)	120Vac, 60 Hz
TRANSFER RATE	6Mbps	DETECTOR FUNCTION	Peak(PK) Average (AV)
ENVIRONMENTAL CONDITIONS	25deg. C, 65%RH, 991hPa	TESTED BY	Lori Chui

ANTENNA POLARITY & TEST DISTANCE: HORIZONTAL AT 3 M								
NO.	FREQ. (MHz)	EMISSION LEVEL (dBuV/m)	LIMIT (dBuV/m)	MARGIN (dB)	ANTENNA HEIGHT (m)	TABLE ANGLE (Degree)	RAW VALUE (dBuV)	CORRECTION FACTOR (dB/m)
1	2390.00	67.53 PK	74.00	-6.47	1.34 H	279	36.32	31.21
2	2390.00	52.24 AV	54.00	-1.76	1.34 H	279	21.03	31.21
3	*2412.00	104.21 PK			1.32 H	278	73.01	31.20
4	*2412.00	93.45 AV			1.32 H	278	62.25	31.20
5	4824.00	48.11 PK	74.00	-25.89	1.02 H	199	11.69	36.42
6	4824.00	34.38 AV	54.00	-19.62	1.02 H	199	-2.04	36.42

ANTENNA POLARITY & TEST DISTANCE: VERTICAL AT 3 M								
NO.	FREQ. (MHz)	EMISSION LEVEL (dBuV/m)	LIMIT (dBuV/m)	MARGIN (dB)	ANTENNA HEIGHT (m)	TABLE ANGLE (Degree)	RAW VALUE (dBuV)	CORRECTION FACTOR (dB/m)
1	2390.00	61.93 PK	74.00	-12.07	1.09 V	79	30.72	31.21
2	2390.00	47.49 AV	54.00	-6.51	1.09 V	79	16.28	31.21
3	*2412.00	97.37 PK			1.08 V	78	66.17	31.20
4	*2412.00	86.70 AV			1.08 V	78	55.50	31.20
5	4824.00	47.54 PK	74.00	-26.46	1.14 V	211	11.12	36.42
6	4824.00	33.13 AV	54.00	-20.87	1.14 V	211	-3.29	36.42

- REMARKS:**
1. Emission level (dBuV/m) = Raw Value (dBuV) + Correction Factor (dB/m).
  2. Correction Factor (dB/m) = Antenna Factor (dB/m) + Cable Factor (dB).
  3. The other emission levels were very low against the limit.
  4. Margin value = Emission level – Limit value.
  5. “ \* “: Fundamental frequency.

EUT TEST CONDITION		MEASUREMENT DETAIL	
CHANNEL	Channel 11	FREQUENCY RANGE	1 ~ 25GHz
MODULATION TYPE	BPSK	INPUT POWER (SYSTEM)	120Vac, 60 Hz
TRANSFER RATE	6Mbps	DETECTOR FUNCTION	Peak(PK) Average (AV)
ENVIRONMENTAL CONDITIONS	25deg. C, 65%RH, 991hPa	TESTED BY	Lori Chui

ANTENNA POLARITY & TEST DISTANCE: HORIZONTAL AT 3 M								
NO.	FREQ. (MHz)	EMISSION LEVEL (dBuV/m)	LIMIT (dBuV/m)	MARGIN (dB)	ANTENNA HEIGHT (m)	TABLE ANGLE (Degree)	RAW VALUE (dBuV)	CORRECTION FACTOR (dB/m)
1	*2462.00	101.92 PK			1.31 H	275	70.70	31.22
2	*2462.00	91.13 AV			1.31 H	275	59.91	31.22
3	2483.50	59.18 PK	74.00	-14.82	1.28 H	275	27.95	31.23
4	2483.50	46.67 AV	54.00	-7.33	1.28 H	275	15.44	31.23
5	4924.00	48.07 PK	74.00	-25.93	1.00 H	297	11.44	36.63
6	4924.00	33.11 AV	54.00	-20.89	1.00 H	297	-3.52	36.63

ANTENNA POLARITY & TEST DISTANCE: VERTICAL AT 3 M								
NO.	FREQ. (MHz)	EMISSION LEVEL (dBuV/m)	LIMIT (dBuV/m)	MARGIN (dB)	ANTENNA HEIGHT (m)	TABLE ANGLE (Degree)	RAW VALUE (dBuV)	CORRECTION FACTOR (dB/m)
1	*2462.00	93.50 PK			1.25 V	233	62.28	31.22
2	*2462.00	83.07 AV			1.25 V	233	51.85	31.22
3	2483.50	55.35 PK	74.00	-18.65	1.23 V	224	24.12	31.23
4	2483.50	44.96 AV	54.00	-9.04	1.23 V	224	13.73	31.23
5	4924.00	46.70 PK	74.00	-27.30	1.10 V	214	10.07	36.63
6	4924.00	32.24 AV	54.00	-21.76	1.10 V	214	-4.39	36.63

- REMARKS:**
1. Emission level (dBuV/m) = Raw Value (dBuV) + Correction Factor (dB/m).
  2. Correction Factor (dB/m) = Antenna Factor (dB/m) + Cable Factor (dB).
  3. The other emission levels were very low against the limit.
  4. Margin value = Emission level – Limit value.
  5. “ \* “: Fundamental frequency.

**DRAFT 802.11n (20MHz) OFDM MODULATION: SINGLE TX**

EUT TEST CONDITION		MEASUREMENT DETAIL	
CHANNEL	Channel 1	FREQUENCY RANGE	1 ~ 25GHz
MODULATION TYPE	BPSK	INPUT POWER (SYSTEM)	120Vac, 60 Hz
TRANSFER RATE	7.2Mbps	DETECTOR FUNCTION	Peak(PK) Average (AV)
ENVIRONMENTAL CONDITIONS	25deg. C, 65%RH, 991hPa	TESTED BY	Lori Chui

ANTENNA POLARITY & TEST DISTANCE: HORIZONTAL AT 3 M								
NO.	FREQ. (MHz)	EMISSION LEVEL (dBuV/m)	LIMIT (dBuV/m)	MARGIN (dB)	ANTENNA HEIGHT (m)	TABLE ANGLE (Degree)	RAW VALUE (dBuV)	CORRECTION FACTOR (dB/m)
1	2390.00	68.20 PK	74.00	-5.80	1.32 H	276	36.99	31.21
2	2390.00	52.99 AV	54.00	-1.01	1.32 H	276	21.78	31.21
3	*2412.00	105.23 PK			1.35 H	274	74.03	31.20
4	*2412.00	94.77 AV			1.35 H	274	63.57	31.20
5	4824.00	51.22 PK	74.00	-22.78	1.01 H	221	14.79	36.42
6	4824.00	35.49 AV	54.00	-18.51	1.01 H	221	-0.94	36.42

ANTENNA POLARITY & TEST DISTANCE: VERTICAL AT 3 M								
NO.	FREQ. (MHz)	EMISSION LEVEL (dBuV/m)	LIMIT (dBuV/m)	MARGIN (dB)	ANTENNA HEIGHT (m)	TABLE ANGLE (Degree)	RAW VALUE (dBuV)	CORRECTION FACTOR (dB/m)
1	2390.00	60.57 PK	74.00	-13.43	1.31 V	231	29.36	31.21
2	2390.00	47.91 AV	54.00	-6.09	1.31 V	231	16.70	31.21
3	*2412.00	96.21 PK			1.31 V	222	65.01	31.20
4	*2412.00	85.92 AV			1.31 V	222	54.72	31.20
5	4824.00	47.24 PK	74.00	-26.76	1.01 V	243	10.81	36.42
6	4824.00	33.48 AV	54.00	-20.52	1.01 V	243	-2.95	36.42

- REMARKS:**
1. Emission level (dBuV/m) = Raw Value (dBuV) + Correction Factor (dB/m).
  2. Correction Factor (dB/m) = Antenna Factor (dB/m) + Cable Factor (dB).
  3. The other emission levels were very low against the limit.
  4. Margin value = Emission level – Limit value.
  5. “ \* “: Fundamental frequency.

EUT TEST CONDITION		MEASUREMENT DETAIL	
CHANNEL	Channel 11	FREQUENCY RANGE	1 ~ 25GHz
MODULATION TYPE	BPSK	INPUT POWER (SYSTEM)	120Vac, 60 Hz
TRANSFER RATE	7.2Mbps	DETECTOR FUNCTION	Peak(PK) Average (AV)
ENVIRONMENTAL CONDITIONS	25deg. C, 65%RH, 991hPa	TESTED BY	Lori Chui

ANTENNA POLARITY & TEST DISTANCE: HORIZONTAL AT 3 M								
NO.	FREQ. (MHz)	EMISSION LEVEL (dBuV/m)	LIMIT (dBuV/m)	MARGIN (dB)	ANTENNA HEIGHT (m)	TABLE ANGLE (Degree)	RAW VALUE (dBuV)	CORRECTION FACTOR (dB/m)
1	*2462.00	103.08 PK			1.28 H	279	71.86	31.22
2	*2462.00	92.59 AV			1.28 H	279	61.37	31.22
3	2483.50	65.56 PK	74.00	-8.44	1.28 H	279	34.33	31.23
4	2483.50	50.11 AV	54.00	-3.89	1.28 H	279	18.88	31.23
5	4924.00	51.03 PK	74.00	-22.97	1.00 H	135	14.40	36.63
6	4924.00	34.89 AV	54.00	-19.11	1.00 H	135	-1.74	36.63

ANTENNA POLARITY & TEST DISTANCE: VERTICAL AT 3 M								
NO.	FREQ. (MHz)	EMISSION LEVEL (dBuV/m)	LIMIT (dBuV/m)	MARGIN (dB)	ANTENNA HEIGHT (m)	TABLE ANGLE (Degree)	RAW VALUE (dBuV)	CORRECTION FACTOR (dB/m)
1	*2462.00	93.69 PK			1.25 V	234	62.47	31.22
2	*2462.00	83.23 AV			1.25 V	234	52.01	31.22
3	2483.50	57.66 PK	74.00	-16.34	1.25 V	234	26.43	31.23
4	2483.50	46.90 AV	54.00	-7.10	1.25 V	234	15.67	31.23
5	4924.00	47.67 PK	74.00	-26.33	1.00 V	35	11.04	36.63
6	4924.00	33.45 AV	54.00	-20.55	1.00 V	35	-3.18	36.63

- REMARKS:**
1. Emission level (dBuV/m) = Raw Value (dBuV) + Correction Factor (dB/m).
  2. Correction Factor (dB/m) = Antenna Factor (dB/m) + Cable Factor (dB).
  3. The other emission levels were very low against the limit.
  4. Margin value = Emission level – Limit value.
  5. “ \* “: Fundamental frequency.

**DRAFT 802.11n (20MHz) OFDM MODULATION: DUAL TX**

EUT TEST CONDITION		MEASUREMENT DETAIL	
CHANNEL	Channel 1	FREQUENCY RANGE	1 ~ 25GHz
MODULATION TYPE	BPSK	INPUT POWER (SYSTEM)	120Vac, 60 Hz
TRANSFER RATE	14.444Mbps	DETECTOR FUNCTION	Peak(PK) Average (AV)
ENVIRONMENTAL CONDITIONS	25deg. C, 65%RH, 991hPa	TESTED BY	Lori Chui

ANTENNA POLARITY & TEST DISTANCE: HORIZONTAL AT 3 M								
NO.	FREQ. (MHz)	EMISSION LEVEL (dBuV/m)	LIMIT (dBuV/m)	MARGIN (dB)	ANTENNA HEIGHT (m)	TABLE ANGLE (Degree)	RAW VALUE (dBuV)	CORRECTION FACTOR (dB/m)
1	2390.00	67.45 PK	74.00	-6.55	1.35 H	267	36.24	31.21
2	2390.00	52.86 AV	54.00	-1.14	1.35 H	267	21.65	31.21
3	*2412.00	107.32 PK			1.31 H	278	76.12	31.20
4	*2412.00	95.57 AV			1.31 H	278	64.37	31.20
5	4824.00	50.77 PK	74.00	-23.23	1.04 H	201	14.34	36.42
6	4824.00	37.06 AV	54.00	-16.94	1.04 H	201	0.63	36.42

ANTENNA POLARITY & TEST DISTANCE: VERTICAL AT 3 M								
NO.	FREQ. (MHz)	EMISSION LEVEL (dBuV/m)	LIMIT (dBuV/m)	MARGIN (dB)	ANTENNA HEIGHT (m)	TABLE ANGLE (Degree)	RAW VALUE (dBuV)	CORRECTION FACTOR (dB/m)
1	2390.00	60.77 PK	74.00	-13.23	1.11 V	76	29.56	31.21
2	2390.00	48.49 AV	54.00	-5.51	1.11 V	76	17.28	31.21
3	*2412.00	100.48 PK			1.10 V	76	69.28	31.20
4	*2412.00	89.15 AV			1.10 V	76	57.95	31.20
5	4824.00	49.64 PK	74.00	-24.36	1.05 V	305	13.21	36.42
6	4824.00	36.53 AV	54.00	-17.47	1.05 V	305	0.10	36.42

- REMARKS:**
1. Emission level (dBuV/m) = Raw Value (dBuV) + Correction Factor (dB/m).
  2. Correction Factor (dB/m) = Antenna Factor (dB/m) + Cable Factor (dB).
  3. The other emission levels were very low against the limit.
  4. Margin value = Emission level – Limit value.
  5. “ \* “: Fundamental frequency.

EUT TEST CONDITION		MEASUREMENT DETAIL	
CHANNEL	Channel 11	FREQUENCY RANGE	1 ~ 25GHz
MODULATION TYPE	BPSK	INPUT POWER (SYSTEM)	120Vac, 60 Hz
TRANSFER RATE	14.444Mbps	DETECTOR FUNCTION	Peak(PK) Average (AV)
ENVIRONMENTAL CONDITIONS	25deg. C, 65%RH, 991hPa	TESTED BY	Lori Chui

ANTENNA POLARITY & TEST DISTANCE: HORIZONTAL AT 3 M								
NO.	FREQ. (MHz)	EMISSION LEVEL (dBuV/m)	LIMIT (dBuV/m)	MARGIN (dB)	ANTENNA HEIGHT (m)	TABLE ANGLE (Degree)	RAW VALUE (dBuV)	CORRECTION FACTOR (dB/m)
1	*2462.00	102.91 PK			1.06 H	216	71.69	31.22
2	*2462.00	92.10 AV			1.06 H	216	60.88	31.22
3	2483.50	59.28 PK	74.00	-14.72	1.04 H	217	28.05	31.23
4	2483.50	49.58 AV	54.00	-4.42	1.04 H	217	18.35	31.23
5	4924.00	48.51 PK	74.00	-25.49	1.08 H	177	11.87	36.63
6	4924.00	34.59 AV	54.00	-19.41	1.08 H	177	-2.05	36.63

ANTENNA POLARITY & TEST DISTANCE: VERTICAL AT 3 M								
NO.	FREQ. (MHz)	EMISSION LEVEL (dBuV/m)	LIMIT (dBuV/m)	MARGIN (dB)	ANTENNA HEIGHT (m)	TABLE ANGLE (Degree)	RAW VALUE (dBuV)	CORRECTION FACTOR (dB/m)
1	*2462.00	96.82 PK			1.08 V	79	65.60	31.22
2	*2462.00	85.58 AV			1.08 V	79	54.36	31.22
3	2483.50	57.34 PK	74.00	-16.66	1.07 V	82	26.11	31.23
4	2483.50	46.21 AV	54.00	-7.79	1.07 V	82	14.98	31.23
5	4924.00	49.02 PK	74.00	-24.98	1.62 V	224	12.39	36.63
6	4924.00	35.72 AV	54.00	-18.28	1.62 V	224	-0.91	36.63

- REMARKS:**
1. Emission level (dBuV/m) = Raw Value (dBuV) + Correction Factor (dB/m).
  2. Correction Factor (dB/m) = Antenna Factor (dB/m) + Cable Factor (dB).
  3. The other emission levels were very low against the limit.
  4. Margin value = Emission level – Limit value.
  5. “ \* “: Fundamental frequency.

**DRAFT 802.11n (40MHz) OFDM MODULATION: SINGLE TX**

EUT TEST CONDITION		MEASUREMENT DETAIL	
CHANNEL	Channel 1	FREQUENCY RANGE	1 ~ 25GHz
MODULATION TYPE	BPSK	INPUT POWER (SYSTEM)	120Vac, 60 Hz
TRANSFER RATE	15Mbps	DETECTOR FUNCTION	Peak(PK) Average (AV)
ENVIRONMENTAL CONDITIONS	25deg. C, 65%RH, 991hPa	TESTED BY	Lori Chui

ANTENNA POLARITY & TEST DISTANCE: HORIZONTAL AT 3 M								
NO.	FREQ. (MHz)	EMISSION LEVEL (dBuV/m)	LIMIT (dBuV/m)	MARGIN (dB)	ANTENNA HEIGHT (m)	TABLE ANGLE (Degree)	RAW VALUE (dBuV)	CORRECTION FACTOR (dB/m)
1	2390.00	68.24 PK	74.00	-5.76	1.33 H	268	37.03	31.21
2	2390.00	52.96 AV	54.00	-1.04	1.33 H	268	21.75	31.21
3	*2422.00	102.94 PK			1.34 H	270	71.73	31.21
4	*2422.00	91.88 AV			1.34 H	270	60.67	31.21
5	4844.00	45.38 PK	74.00	-28.62	1.33 H	120	8.92	36.46
6	4844.00	33.95 AV	54.00	-20.05	1.33 H	120	-2.51	36.46

ANTENNA POLARITY & TEST DISTANCE: VERTICAL AT 3 M								
NO.	FREQ. (MHz)	EMISSION LEVEL (dBuV/m)	LIMIT (dBuV/m)	MARGIN (dB)	ANTENNA HEIGHT (m)	TABLE ANGLE (Degree)	RAW VALUE (dBuV)	CORRECTION FACTOR (dB/m)
1	2390.00	58.33 PK	74.00	-15.67	1.27 V	232	27.12	31.21
2	2390.00	46.93 AV	54.00	-7.07	1.27 V	232	15.72	31.21
3	*2422.00	93.76 PK			1.28 V	220	62.55	31.21
4	*2422.00	83.32 AV			1.28 V	220	52.11	31.21
5	4844.00	47.77 PK	74.00	-26.23	1.30 V	174	11.31	36.46
6	4844.00	34.76 AV	54.00	-19.24	1.30 V	174	-1.70	36.46

- REMARKS:**
1. Emission level (dBuV/m) = Raw Value (dBuV) + Correction Factor (dB/m).
  2. Correction Factor (dB/m) = Antenna Factor (dB/m) + Cable Factor (dB).
  3. The other emission levels were very low against the limit.
  4. Margin value = Emission level – Limit value.
  5. “ \* “: Fundamental frequency.

EUT TEST CONDITION		MEASUREMENT DETAIL	
CHANNEL	Channel 7	FREQUENCY RANGE	1 ~ 25GHz
MODULATION TYPE	BPSK	INPUT POWER (SYSTEM)	120Vac, 60 Hz
TRANSFER RATE	15Mbps	DETECTOR FUNCTION	Peak(PK) Average (AV)
ENVIRONMENTAL CONDITIONS	25deg. C, 65%RH, 991hPa	TESTED BY	Lori Chui

ANTENNA POLARITY & TEST DISTANCE: HORIZONTAL AT 3 M								
NO.	FREQ. (MHz)	EMISSION LEVEL (dBuV/m)	LIMIT (dBuV/m)	MARGIN (dB)	ANTENNA HEIGHT (m)	TABLE ANGLE (Degree)	RAW VALUE (dBuV)	CORRECTION FACTOR (dB/m)
1	*2452.00	101.97 PK			1.30 H	276	70.75	31.22
2	*2452.00	91.04 AV			1.30 H	276	59.82	31.22
3	2483.50	65.70 PK	74.00	-8.30	1.30 H	274	34.47	31.23
4	2483.50	52.48 AV	54.00	-1.52	1.30 H	274	21.25	31.23
5	4904.00	45.13 PK	74.00	-28.87	1.02 H	237	8.54	36.59
6	4904.00	33.84 AV	54.00	-20.16	1.02 H	237	-2.75	36.59

ANTENNA POLARITY & TEST DISTANCE: VERTICAL AT 3 M								
NO.	FREQ. (MHz)	EMISSION LEVEL (dBuV/m)	LIMIT (dBuV/m)	MARGIN (dB)	ANTENNA HEIGHT (m)	TABLE ANGLE (Degree)	RAW VALUE (dBuV)	CORRECTION FACTOR (dB/m)
1	*2452.00	96.79 PK			1.06 V	78	65.57	31.22
2	*2452.00	85.90 AV			1.06 V	78	54.68	31.22
3	2483.50	60.03 PK	74.00	-13.97	1.05 V	81	28.80	31.23
4	2483.50	48.54 AV	54.00	-5.46	1.05 V	81	17.31	31.23
5	4904.00	47.65 PK	74.00	-26.35	1.33 V	205	11.06	36.59
6	4904.00	34.52 AV	54.00	-19.48	1.33 V	205	-2.07	36.59

- REMARKS:**
1. Emission level (dBuV/m) = Raw Value (dBuV) + Correction Factor (dB/m).
  2. Correction Factor (dB/m) = Antenna Factor (dB/m) + Cable Factor (dB).
  3. The other emission levels were very low against the limit.
  4. Margin value = Emission level – Limit value.
  5. “ \* “: Fundamental frequency.

**DRAFT 802.11n (40MHz) OFDM MODULATION: DUAL TX**

EUT TEST CONDITION		MEASUREMENT DETAIL	
CHANNEL	Channel 1	FREQUENCY RANGE	1 ~ 25GHz
MODULATION TYPE	BPSK	INPUT POWER (SYSTEM)	120Vac, 60 Hz
TRANSFER RATE	30Mbps	DETECTOR FUNCTION	Peak(PK) Average (AV)
ENVIRONMENTAL CONDITIONS	25deg. C, 65%RH, 991hPa	TESTED BY	Lori Chui

ANTENNA POLARITY & TEST DISTANCE: HORIZONTAL AT 3 M								
NO.	FREQ. (MHz)	EMISSION LEVEL (dBuV/m)	LIMIT (dBuV/m)	MARGIN (dB)	ANTENNA HEIGHT (m)	TABLE ANGLE (Degree)	RAW VALUE (dBuV)	CORRECTION FACTOR (dB/m)
1	2390.00	66.60 PK	74.00	-7.40	1.36 H	344	35.39	31.21
2	2390.00	52.87 AV	54.00	-1.13	1.36 H	344	21.66	31.21
3	*2422.00	103.37 PK			1.33 H	275	72.16	31.21
4	*2422.00	91.52 AV			1.33 H	275	60.31	31.21
5	4844.00	45.46 PK	74.00	-28.54	1.23 H	255	9.00	36.46
6	4844.00	32.05 AV	54.00	-21.95	1.23 H	255	-4.41	36.46

ANTENNA POLARITY & TEST DISTANCE: VERTICAL AT 3 M								
NO.	FREQ. (MHz)	EMISSION LEVEL (dBuV/m)	LIMIT (dBuV/m)	MARGIN (dB)	ANTENNA HEIGHT (m)	TABLE ANGLE (Degree)	RAW VALUE (dBuV)	CORRECTION FACTOR (dB/m)
1	2390.00	58.92 PK	74.00	-15.08	1.04 V	222	27.71	31.21
2	2390.00	47.55 AV	54.00	-6.45	1.04 V	222	16.34	31.21
3	*2422.00	95.20 PK			1.29 V	219	63.99	31.21
4	*2422.00	83.44 AV			1.29 V	219	52.23	31.21
5	4844.00	46.88 PK	74.00	-27.12	1.04 V	0	10.42	36.46
6	4844.00	34.22 AV	54.00	-19.78	1.04 V	0	-2.24	36.46

- REMARKS:**
1. Emission level (dBuV/m) = Raw Value (dBuV) + Correction Factor (dB/m).
  2. Correction Factor (dB/m) = Antenna Factor (dB/m) + Cable Factor (dB).
  3. The other emission levels were very low against the limit.
  4. Margin value = Emission level – Limit value.
  5. “ \* “: Fundamental frequency.

EUT TEST CONDITION		MEASUREMENT DETAIL	
CHANNEL	Channel 7	FREQUENCY RANGE	1 ~ 25GHz
MODULATION TYPE	BPSK	INPUT POWER (SYSTEM)	120Vac, 60 Hz
TRANSFER RATE	30Mbps	DETECTOR FUNCTION	Peak(PK) Average (AV)
ENVIRONMENTAL CONDITIONS	25deg. C, 65%RH, 991hPa	TESTED BY	Lori Chui

ANTENNA POLARITY & TEST DISTANCE: HORIZONTAL AT 3 M								
NO.	FREQ. (MHz)	EMISSION LEVEL (dBuV/m)	LIMIT (dBuV/m)	MARGIN (dB)	ANTENNA HEIGHT (m)	TABLE ANGLE (Degree)	RAW VALUE (dBuV)	CORRECTION FACTOR (dB/m)
1	*2452.00	102.31 PK			1.05 H	215	71.09	31.22
2	*2452.00	90.38 AV			1.05 H	215	59.16	31.22
3	2483.50	66.04 PK	74.00	-7.96	1.05 H	217	34.81	31.23
4	2483.50	51.76 AV	54.00	-2.24	1.05 H	217	20.53	31.23
5	4904.00	45.37 PK	74.00	-28.63	1.22 H	52	8.78	36.59
6	4904.00	31.99 AV	54.00	-22.01	1.22 H	52	-4.60	36.59

ANTENNA POLARITY & TEST DISTANCE: VERTICAL AT 3 M								
NO.	FREQ. (MHz)	EMISSION LEVEL (dBuV/m)	LIMIT (dBuV/m)	MARGIN (dB)	ANTENNA HEIGHT (m)	TABLE ANGLE (Degree)	RAW VALUE (dBuV)	CORRECTION FACTOR (dB/m)
1	*2452.00	94.43 PK			1.09 V	77	63.21	31.22
2	*2452.00	83.14 AV			1.09 V	77	51.92	31.22
3	2483.50	60.91 PK	74.00	-13.09	1.15 V	52	29.68	31.23
4	2483.50	48.41 AV	54.00	-5.59	1.15 V	52	17.18	31.23
5	4904.00	47.62 PK	74.00	-26.38	1.08 V	164	11.03	36.59
6	4904.00	33.57 AV	54.00	-20.43	1.08 V	164	-3.02	36.59

- REMARKS:**
1. Emission level (dBuV/m) = Raw Value (dBuV) + Correction Factor (dB/m).
  2. Correction Factor (dB/m) = Antenna Factor (dB/m) + Cable Factor (dB).
  3. The other emission levels were very low against the limit.
  4. Margin value = Emission level – Limit value.
  5. “ \* “: Fundamental frequency.



### 4.3 MAXIMUM PEAK OUTPUT POWER

#### 4.3.1 LIMITS OF MAXIMUM PEAK OUTPUT POWER MEASUREMENT

The Maximum Peak Output Power Measurement is 30dBm.

#### 4.3.2 INSTRUMENTS

DESCRIPTION & MANUFACTURER	MODEL NO.	SERIAL NO.	CALIBRATED UNTIL
R&S SPECTRUM ANALYZER	FSP40	100040	Jun. 07, 2007
AGILENT SIGNAL GENERATOR	E8257C	MY43320668	Dec. 07, 2006
DIGITAL RT OSCILLOSCOPE	TDS1012	C037299	Nov. 28, 2006
NARDA DETECTOR	4503A	FSCM99899	NA

**NOTE:** The calibration interval of the above test instruments is 12 months and the calibrations are traceable to NML/ROC and NIST/USA.

#### 4.3.3 TEST PROCEDURES

- a. A detector was used on the output port of the EUT. An oscilloscope was used to read the response of the detector.
- b. Replaced the EUT by the signal generator. The center frequency of the S.G was adjusted to the center frequency of the measured channel.
- c. Adjusted the power to have the same reading on oscilloscope. Record the power level.

#### 4.3.4 DEVIATION FROM TEST STANDARD

No deviation

#### 4.3.5 TEST SETUP

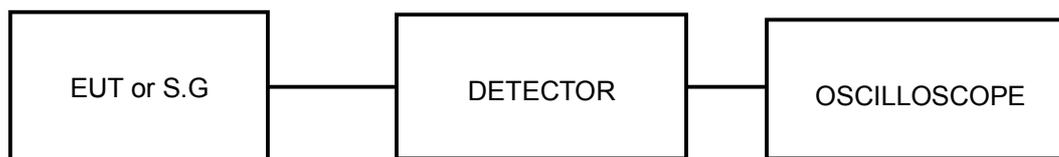

#### 4.3.6 EUT OPERATING CONDITIONS

The software provided by client to enable the EUT under transmission condition continuously at lowest, middle and highest channel frequencies individually.

### 4.3.7 TEST RESULTS

#### 802.11b DSSS MODULATION:

<b>MODULATION TYPE</b>	DBPSK	<b>TRANSFER RATE</b>	1Mbps
<b>INPUT POWER (SYSTEM)</b>	120Vac, 60 Hz	<b>ENVIRONMENTAL CONDITIONS</b>	25deg.C, 63%RH, 991hPa
<b>TESTED BY</b>	Match Tsui		

CHANNEL	CHANNEL FREQUENCY (MHz)	PEAK POWER OUTPUT (mW)	PEAK POWER OUTPUT (dBm)	PEAK POWER LIMIT (dBm)	PASS / FAIL
1	2412	41.400	16.17	30	PASS
6	2437	60.256	17.80	30	PASS
11	2462	63.387	18.02	30	PASS

#### 802.11g OFDM MODULATION:

<b>MODULATION TYPE</b>	BPSK	<b>TRANSFER RATE</b>	6Mbps
<b>INPUT POWER (SYSTEM)</b>	120Vac, 60 Hz	<b>ENVIRONMENTAL CONDITIONS</b>	25deg.C, 63%RH, 991hPa
<b>TESTED BY</b>	Match Tsui		

CHANNEL	CHANNEL FREQUENCY (MHz)	PEAK POWER OUTPUT (mW)	PEAK POWER OUTPUT (dBm)	PEAK POWER LIMIT (dBm)	PASS / FAIL
1	2412	50.119	17.00	30	PASS
6	2437	50.350	17.02	30	PASS
11	2462	32.063	15.06	30	PASS



**DRAFT 802.11n (20MHz) OFDM MODULATION: SINGLE TX:**

<b>MODULATION TYPE</b>	BPSK	<b>TRANSFER RATE</b>	7.2Mbps
<b>INPUT POWER (SYSTEM)</b>	120Vac, 60 Hz	<b>ENVIRONMENTAL CONDITIONS</b>	25deg.C, 63%RH, 991hPa
<b>TESTED BY</b>	Match Tsui		

CHANNEL	CHANNEL FREQUENCY (MHz)	PEAK POWER OUTPUT (mW)	PEAK POWER OUTPUT (dBm)	PEAK POWER LIMIT (dBm)	PASS / FAIL
1	2412	73.282	18.65	30	PASS
6	2437	80.168	19.04	30	PASS
11	2462	39.811	16.00	30	PASS

**DRAFT 802.11n (20MHz) OFDM MODULATION: DUAL TX:**

<b>MODULATION TYPE</b>	BPSK	<b>TRANSFER RATE</b>	14.444Mbps
<b>INPUT POWER (SYSTEM)</b>	120Vac, 60 Hz	<b>ENVIRONMENTAL CONDITIONS</b>	25deg.C, 63%RH, 991hPa
<b>TESTED BY</b>	Match Tsui		

CHANNEL	CHANNEL FREQUENCY (MHz)	PEAK POWER OUTPUT (mW)		PEAK POWER OUTPUT (dBm)		TOTAL PEAK POWER (mW)	TOTAL PEAK POWER (dBm)	PEAK POWER LIMIT (dBm)	PASS / FAIL
		CHAIN 0	CHAIN 1	CHAIN 0	CHAIN 1				
1	2412	48.306	47.643	16.84	16.78	95.949	19.82	30	PASS
6	2437	79.616	79.799	19.01	19.02	159.415	22.03	30	PASS
11	2462	20.091	20.324	13.03	13.08	40.415	16.07	30	PASS



**DRAFT 802.11n (40MHz) OFDM MODULATION: SINGLE TX:**

<b>MODULATION TYPE</b>	BPSK	<b>TRANSFER RATE</b>	15Mbps
<b>INPUT POWER (SYSTEM)</b>	120Vac, 60 Hz	<b>ENVIRONMENTAL CONDITIONS</b>	25deg.C, 63%RH, 991hPa
<b>TESTED BY</b>	Match Tsui		

CHANNEL	CHANNEL FREQUENCY (MHz)	PEAK POWER OUTPUT (mW)	PEAK POWER OUTPUT (dBm)	PEAK POWER LIMIT (dBm)	PASS / FAIL
1	2422	35.727	15.53	30	PASS
4	2437	35.563	15.51	30	PASS
7	2452	31.842	15.03	30	PASS

**DRAFT 802.11n (40MHz) OFDM MODULATION: DUAL TX:**

<b>MODULATION TYPE</b>	BPSK	<b>TRANSFER RATE</b>	30Mbps
<b>INPUT POWER (SYSTEM)</b>	120Vac, 60 Hz	<b>ENVIRONMENTAL CONDITIONS</b>	25deg.C, 63%RH, 991hPa
<b>TESTED BY</b>	Match Tsui		

CHANNEL	CHANNEL FREQUENCY (MHz)	PEAK POWER OUTPUT (mW)		PEAK POWER OUTPUT (dBm)		TOTAL PEAK POWER (mW)	TOTAL PEAK POWER (dBm)	PEAK POWER LIMIT (dBm)	PASS / FAIL
		CHAIN 0	CHAIN 1	CHAIN 0	CHAIN 1				
1	2422	29.854	30.200	14.75	14.80	60.054	17.79	30	PASS
4	2437	31.769	31.915	15.02	15.04	63.684	18.04	30	PASS
7	2452	25.235	25.586	14.02	14.08	50.821	17.06	30	PASS



## 6. INFORMATION ON THE TESTING LABORATORIES

We, ADT Corp., were founded in 1988 to provide our best service in EMC, Radio, Telecom and Safety consultation. Our laboratories are accredited and approved by the following approval agencies according to ISO/IEC 17025.

<b>USA</b>	FCC, UL, A2LA
<b>Germany</b>	TUV Rheinland
<b>Japan</b>	VCCI
<b>Norway</b>	NEMKO
<b>Canada</b>	INDUSTRY CANADA , CSA
<b>R.O.C.</b>	CNLA, BSMI, NCC
<b>Netherlands</b>	Telefication
<b>Singapore</b>	PSB , GOST-ASIA(MOU)
<b>Russia</b>	CERTIS(MOU)

Copies of accreditation certificates of our laboratories obtained from approval agencies can be downloaded from our web site:

[www.adt.com.tw/index.5/phtml](http://www.adt.com.tw/index.5/phtml). If you have any comments, please feel free to contact us at the following:

**Linko EMC/RF Lab:**

Tel: 886-2-26052180

Fax: 886-2-26051924

**Hsin Chu EMC/RF Lab:**

Tel: 886-3-5935343

Fax: 886-3-5935342

**Hwa Ya EMC/RF/Safety Telecom Lab:**

Tel: 886-3-3183232

Fax: 886-3-3185050

**Web Site:** [www.adt.com.tw](http://www.adt.com.tw)

The address and road map of all our labs can be found in our web site also.



## **APPENDIX-A**

### **MODIFICATIONS RECORDERS FOR ENGINEERING CHANGES TO THE EUT BY THE LAB**

No any modifications are made to the EUT by the lab during the test.