



FCC TEST REPORT (15.407)

REPORT NO.: RF970409L18A

MODEL NO.: DIR-628

RECEIVED: Apr. 11, 2008

TESTED: Apr. 17 ~ May 05, 2008

ISSUED: Dec. 29, 2008

APPLICANT: D-Link Corporation

ADDRESS: 17595 Mt. Herrmann, Fountain Valley, CA
92708, U.S.A.

ISSUED BY: Bureau Veritas Consumer Products Services
(H.K.) Ltd., Taoyuan Branch

LAB ADDRESS: No. 47, 14th Ling, Chia Pau Tsuen, Lin Kou
Hsiang, Taipei Hsien 244, Taiwan, R.O.C.

TEST LOCATION: No. 19, Hwa Ya 2nd Rd, Wen Hwa Tsuen, Kwei
Shan Hsiang, Taoyuan Hsien 333, Taiwan,
R.O.C.

This test report consists of 148 pages in total. It may be duplicated completely for legal use with the approval of the applicant. It should not be reproduced except in full, without the written approval of our laboratory. The client should not use it to claim product endorsement by TAF or any government agencies. The test results in the report only apply to the tested sample.





TABLE OF CONTENTS

1.	CERTIFICATION.....	4
2.	SUMMARY OF TEST RESULTS	5
2.1	MEASUREMENT UNCERTAINTY	5
3.	GENERAL INFORMATION.....	6
3.1	GENERAL DESCRIPTION OF EUT	6
3.2	DESCRIPTION OF TEST MODES.....	7
3.2.1	CONFIGURATION OF SYSTEM UNDER TEST	8
3.2.2	TEST MODE APPLICABILITY AND TESTED CHANNEL DETAIL.....	9
3.3	GENERAL DESCRIPTION OF APPLIED STANDARDS	11
3.4	DESCRIPTION OF SUPPORT UNITS	11
4.	TEST TYPES AND RESULTS	12
4.1	RADIATED EMISSION MEASUREMENT	12
4.1.1	LIMITS OF RADIATED EMISSION MEASUREMENT.....	12
4.1.2	LIMITS OF UNWANTED EMISSION OUT OF THE RESTRICTED BANDS.....	12
4.1.3	TEST INSTRUMENTS	13
4.1.4	TEST PROCEDURES	14
4.1.5	DEVIATION FROM TEST STANDARD	14
4.1.6	TEST SETUP	15
4.1.7	EUT OPERATING CONDITION	15
4.1.8	TEST RESULTS	16
4.2	CONDUCTED EMISSION MEASUREMENT	35
4.2.1	LIMITS OF CONDUCTED EMISSION MEASUREMENT.....	35
4.2.2	TEST INSTRUMENTS	35
4.2.3	TEST PROCEDURES	36
4.2.4	DEVIATION FROM TEST STANDARD	36
4.2.5	TEST SETUP	37
4.2.6	EUT OPERATING CONDITIONS.....	37
4.2.7	TEST RESULTS	38
4.3	PEAK TRANSMIT POWER MEASUREMENT	42
4.3.1	LIMITS OF PEAK TRANSMIT POWER MEASUREMENT.....	42
4.3.2	TEST INSTRUMENTS	42
4.3.3	TEST PROCEDURE	42
4.3.4	DEVIATION FROM TEST STANDARD	43
4.3.5	TEST SETUP	43
4.3.6	EUT OPERATING CONDITIONS.....	43
4.3.7	TEST RESULTS	44
4.4	PEAK POWER EXCURSION MEASUREMENT	78
4.4.1	LIMITS OF PEAK POWER EXCURSION MEASUREMENT.....	78
4.4.2	TEST INSTRUMENTS	78
4.4.3	TEST PROCEDURE	78
4.4.4	DEVIATION FROM TEST STANDARD	79
4.4.5	TEST SETUP	79
4.4.6	EUT OPERATING CONDITIONS.....	79
4.4.7	TEST RESULTS	80
4.5	PEAK POWER SPECTRAL DENSITY MEASUREMENT	97
4.5.1	LIMITS OF PEAK POWER SPECTRAL DENSITY MEASUREMENT.....	97
4.5.2	TEST INSTRUMENTS	97
4.5.3	TEST PROCEDURES	97



A D T

4.5.4	DEVIATION FROM TEST STANDARD	98
4.5.5	TEST SETUP	98
4.5.6	EUT OPERATING CONDITIONS	98
4.5.7	TEST RESULTS	99
4.6	FREQUENCY STABILITY	116
4.6.1	LIMITS OF FREQUENCY STABILITY MEASUREMENT	116
4.6.2	TEST INSTRUMENTS	116
4.6.3	TEST PROCEDURE	116
4.6.4	DEVIATION FROM TEST STANDARD	117
4.6.5	TEST SETUP	117
4.6.6	EUT OPERATING CONDITION	117
4.6.7	TEST RESULTS	118
4.7	BAND EDGES MEASUREMENT	119
4.7.1	TEST INSTRUMENTS	119
4.7.2	TEST PROCEDURE	120
4.7.3	EUT OPERATING CONDITION	120
4.7.4	TEST RESULTS	121
4.8	ANTENNA REQUIREMENT	145
4.8.1	STANDARD APPLICABLE	145
4.8.2	ANTENNA CONNECTED CONSTRUCTION	145
5.	PHOTOGRAPHS OF THE TEST CONFIGURATION	146
6.	INFORMATION ON THE TESTING LABORATORIES	147
7.	APPENDIX A - MODIFICATIONS RECORDERS FOR ENGINEERING CHANGES TO THE EUT BY THE LAB	148



1. CERTIFICATION

PRODUCT: RangeBooster N Dual Band Router

MODEL: DIR-628

BRAND: D-Link

APPLICANT: D-Link Corporation

TEST SAMPLE: ENGINEERING SAMPLE

TESTED: Apr. 17 ~ May 05, 2008

STANDARDS: FCC Part 15, Subpart E (Section 15.407)
ANSI C63.4-2003

The above equipment (Model: DIR-628) has been tested by **Bureau Veritas Consumer Products Services (H.K.) Ltd., Taoyuan Branch**, and found compliance with the requirement of the above standards. The test record, data evaluation & Equipment Under Test (EUT) configurations represented herein are true and accurate accounts of the measurements of the sample's EMC characteristics under the conditions specified in this report.

PREPARED BY : Peggy Chen , **DATE:** Dec. 29, 2008
Peggy Chen / Specialist

TECHNICAL ACCEPTANCE : Long Chen , **DATE:** Dec. 29, 2008
Responsible for RF Long Chen / Senior Engineer

APPROVED BY : Gary Chang , **DATE:** Dec. 29, 2008
Gary Chang / Assistant Manager

2. SUMMARY OF TEST RESULTS

The EUT has been tested according to the following specifications:

APPLIED STANDARD: FCC PART 15, SUBPART E (SECTION 15.407)			
STANDARD SECTION	TEST TYPE AND LIMIT	RESULT	REMARK
15.407(b)(5)	AC Power Conducted Emission	PASS	Meet the requirement of limit. Minimum passing margin is -12.93dB at 0.163MHz.
15.407(b/1/2/3) (b)(5)	Electric Field Strength Spurious Emissions, 30MHz ~ 40000MHz	PASS	Meet the requirement of limit. Minimum passing margin is -1.04dB at 5725.00MHz.
15.407(a/1/2/3)	Peak Transmit Power	PASS	Meet the requirement of limit.
15.407(a)(6)	Peak Power Excursion	PASS	Meet the requirement of limit.
15.407(a/1/2/3)	Peak Power Spectral Density	PASS	Meet the requirement of limit.
15.407(g)	Frequency Stability	PASS	Meet the requirement of limit.

2.1 MEASUREMENT UNCERTAINTY

Where relevant, the following measurement uncertainty levels have been estimated for tests performed on the EUT as specified in CISPR 16-4-2:

MEASUREMENT	FREQUENCY	UNCERTAINTY
Conducted emissions	9kHz~30MHz	2.44 dB
Radiated emissions	30MHz ~ 200MHz	2.93 dB
	200MHz ~1000MHz	2.95 dB
	1GHz ~ 18GHz	2.26 dB
	18GHz ~ 40GHz	1.94 dB

This uncertainty represents an expanded uncertainty expressed at approximately the 95% confidence level using a coverage factor of $k = 2$.

3. GENERAL INFORMATION

3.1 GENERAL DESCRIPTION OF EUT

EUT	RangeBooster N Dual Band Router
MODEL NO.	DIR-628
FCC ID	KA2DIR628A2
POWER SUPPLY	12Vdc from AC adapter
MODULATION TYPE	CCK, DQPSK, DBPSK for DSSS 64QAM, 16QAM, QPSK, BPSK for OFDM
MODULATION TECHNOLOGY	DSSS, OFDM
TRANSFER RATE	802.11a: 54.0/ 48.0/ 36.0/ 24.0/ 18.0/ 12.0/ 9.0/ 6.0Mbps Draft 802.11n: up to 300Mbps
FREQUENCY RANGE	5250 ~ 5350MHz, 5470 ~ 5725MHz
NUMBER OF CHANNEL	5250 ~ 5350MHz: 4 for 802.11a, draft 802.11n (20MHz) 2 for draft 802.11n (40MHz) 5470 ~ 5725MHz: 11 for 802.11a, draft 802.11n (20MHz) 5 for draft 802.11n (40MHz)
OUTPUT POWER	32.549mW for 5250.0 ~ 5350.0MHz 32.549mW for 5470.0 ~ 5725.0MHz
ANTENNA TYPE	Dipole antenna with 2.0dBi gain
DATA CABLE	NA
I/O PORTS	RJ45
ACCESSORY DEVICES	Adapter

NOTE:

1. This report is based on ADT report with Reference No.: RF970409L18. The original report was issued by Advance Data Technology Corp. (ADT Corp.) on May 13, 2008. ADT Corp. is one of Bureau Veritas family and she has fully transferred all its test facilities, staffs & service system to Bureau Veritas Consumer Products Services (Hong Kong) Limited, Taoyuan Branch in 2008.
2. This report is prepared for FCC class II permissive change. The difference compared with the original report is adding frequency band from 5.25 to 5.35GHz and 5.47 to 5.725GHz by software.
3. The EUT was powered by the following adapter:

BRAND:	D-Link
MODEL:	AF 1805-A
INPUT:	100-120Vac, 50-60Hz, 0.4A
OUTPUT:	5Vdc, 2.5A
POWER LINE:	1.8m non-shielded cable without core

4. The EUT incorporates a MIMO function. Physically, the EUT provides two completed transmitters and two receivers.

MODULATION MODE	TX FUNCTION
802.11a	1TX
Draft 802.11n (20MHz)	2TX
Draft 802.11n (40MHz)	2TX

5. The above EUT information was declared by manufacturer and for more detailed features description, please refer to the manufacturer's specifications or user's manual.

3.2 DESCRIPTION OF TEST MODES

Operated in 5250 ~ 5350MHz:

4 channels are provided for 802.11a, draft 802.11n (20MHz):

CHANNEL	FREQUENCY	CHANNEL	FREQUENCY
52	5260MHz	60	5300MHz
56	5280MHz	64	5320MHz

2 channels are provided for draft 802.11n (40MHz):

CHANNEL	FREQUENCY	CHANNEL	FREQUENCY
54	5270MHz	62	5310MHz

Operated in 5470 ~ 5725MHz:

11 channels are provided to this EUT.

CHANNEL	FREQUENCY	CHANNEL	FREQUENCY
100	5500MHz	124	5620MHz
104	5520MHz	128	5640MHz
108	5540MHz	132	5660MHz
112	5560MHz	136	5680MHz
116	5580MHz	140	5700MHz
120	5600MHz		

5 channels are provided for draft 802.11n (40MHz):

CHANNEL	FREQUENCY	CHANNEL	FREQUENCY
102	5510MHz	126	5630MHz
110	5550MHz	134	5670MHz
118	5590MHz		

3.2.1 CONFIGURATION OF SYSTEM UNDER TEST

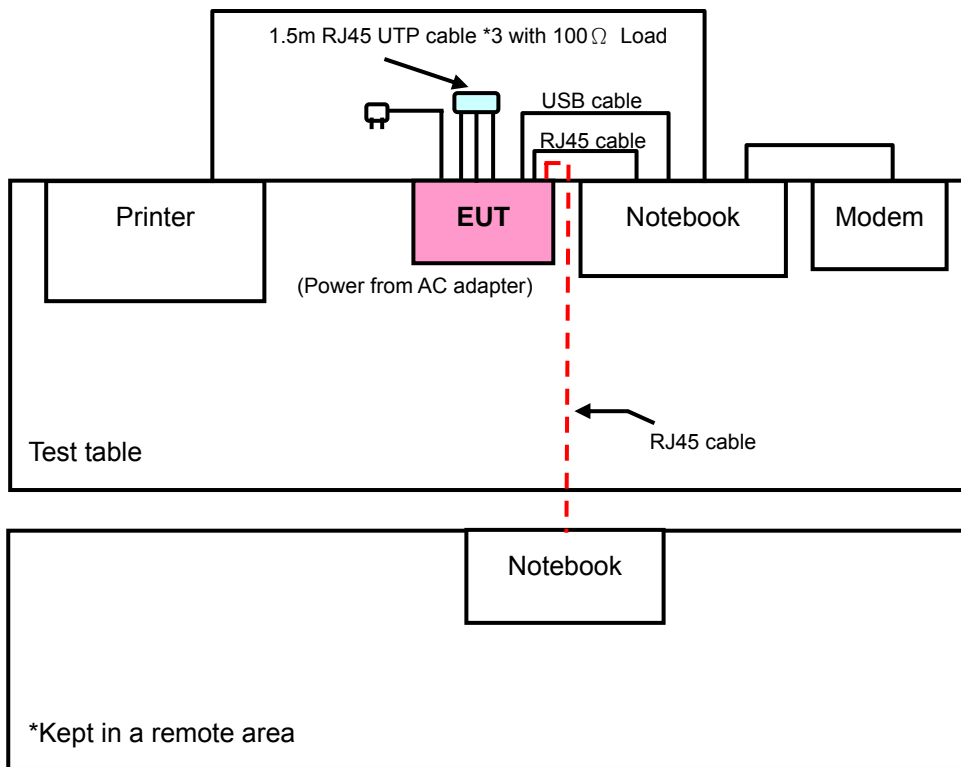

3.2.2 TEST MODE APPLICABILITY AND TESTED CHANNEL DETAIL

EUT CONFIGURE MODE	APPLICABLE TO				DESCRIPTION
	RE \geq 1G	RE<1G	PLC	APCM	
-	√	√	√	√	-

Where **RE \geq 1G**: Radiated Emission above 1GHz **RE<1G**: Radiated Emission below 1GHz
PLC: Power Line Conducted Emission **APCM**: Antenna Port Conducted Measurement

RADIATED EMISSION TEST (ABOVE 1GHz):

- Pre-Scan has been conducted to determine the worst-case mode from all possible combinations between available modulations, data rates and antenna ports (if EUT with antenna diversity architecture).
- Following channel(s) was (were) selected for the final test as listed below.

MODE	FREQ. BAND (MHz)	AVAILABLE CHANNEL	TESTED CHANNEL	MODULATION TECHNOLOGY	MODULATION TYPE	DATA RATE (Mbps)
802.11a	5250-5350	52 to 64	52, 60, 64	OFDM	BPSK	6.0
Draft 802.11n (20MHz)		52 to 64	52, 60, 64	OFDM	BPSK	7.2
Draft 802.11n (40MHz)		54 to 62	54, 62	OFDM	BPSK	15.0
802.11a	5470-5725	100 to 140	100, 120, 140	OFDM	BPSK	6.0
Draft 802.11n (20MHz)		100 to 140	100, 120, 140	OFDM	BPSK	7.2
Draft 802.11n (40MHz)		102 to 134	102, 118, 134	OFDM	BPSK	15.0

RADIATED EMISSION TEST (BELOW 1GHz):

- Pre-Scan has been conducted to determine the worst-case mode from all possible combinations between available modulations, data rates and antenna ports (if EUT with antenna diversity architecture).
- Following channel(s) was (were) selected for the final test as listed below.

MODE	FREQ. BAND (MHz)	AVAILABLE CHANNEL	TESTED CHANNEL	MODULATION TECHNOLOGY	MODULATION TYPE	DATA RATE (Mbps)
802.11a	5250-5350	52 to 64	60	OFDM	BPSK	6.0
802.11a	5470-5725	100 to 140	100	OFDM	BPSK	6.0

POWER LINE CONDUCTED EMISSION TEST:

- Pre-Scan has been conducted to determine the worst-case mode from all possible combinations between available modulations, data rates and antenna ports (if EUT with antenna diversity architecture).
- Following channel(s) was (were) selected for the final test as listed below.

MODE	FREQ. BAND (MHz)	AVAILABLE CHANNEL	TESTED CHANNEL	MODULATION TECHNOLOGY	MODULATION TYPE	DATA RATE (Mbps)
802.11a	5250-5350	52 to 64	60	OFDM	BPSK	6.0
802.11a	5470-5725	100 to 140	100	OFDM	BPSK	6.0

BANDEDGE MEASUREMENT:

- Pre-Scan has been conducted to determine the worst-case mode from all possible combinations between available modulations, data rates and antenna ports (if EUT with antenna diversity architecture).
- Following channel(s) was (were) selected for the final test as listed below.

MODE	FREQ. BAND (MHz)	AVAILABLE CHANNEL	TESTED CHANNEL	MODULATION TECHNOLOGY	MODULATION TYPE	DATA RATE (Mbps)
802.11a	5250-5350	52 to 64	52, 64	OFDM	BPSK	6.0
Draft 802.11n (20MHz)		52 to 64	52, 64	OFDM	BPSK	7.2
Draft 802.11n (40MHz)		54 to 62	54, 62	OFDM	BPSK	15.0
802.11a	5470-5725	100 to 140	100, 140	OFDM	BPSK	6.0
Draft 802.11n (20MHz)		100 to 140	100, 140	OFDM	BPSK	7.2
Draft 802.11n (40MHz)		102 to 134	102, 134	OFDM	BPSK	15.0

ANTENNA PORT CONDUCTED MEASUREMENT:

- Pre-Scan has been conducted to determine the worst-case mode from all possible combinations between available modulations, data rates and antenna ports (if EUT with antenna diversity architecture).
- Following channel(s) was (were) selected for the final test as listed below.

MODE	FREQ. BAND (MHz)	AVAILABLE CHANNEL	TESTED CHANNEL	MODULATION TECHNOLOGY	MODULATION TYPE	DATA RATE (Mbps)
802.11a	5250-5350	52 to 64	52, 60, 64	OFDM	BPSK	6.0
Draft 802.11n (20MHz)		52 to 64	52, 60, 64	OFDM	BPSK	7.2
Draft 802.11n (40MHz)		54 to 62	54, 62	OFDM	BPSK	15.0
802.11a	5470-5725	100 to 140	100, 120, 140	OFDM	BPSK	6.0
Draft 802.11n (20MHz)		100 to 140	100, 120, 140	OFDM	BPSK	7.2
Draft 802.11n (40MHz)		102 to 134	102, 118, 134	OFDM	BPSK	15.0

3.3 GENERAL DESCRIPTION OF APPLIED STANDARDS

The EUT is a RF Product. According to the specifications of the manufacturer, it must comply with the requirements of the following standards:

FCC Part 15, Subpart E (15.407)

ANSI C63.4-2003

All test items have been performed and recorded as per the above standards.

NOTE: The EUT is also considered as a kind of computer peripheral, because the connection to computer is necessary for typical use. It has been verified to comply with the requirements of FCC Part 15, Subpart B, Class B (DoC). The test report has been issued separately.

3.4 DESCRIPTION OF SUPPORT UNITS

The EUT has been tested as an independent unit together with other necessary accessories or support units. The following support units or accessories were used to form a representative test configuration during the tests.

NO.	PRODUCT	BRAND	MODEL NO.	SERIAL NO.	FCC ID
1	NOTEBOOK COMPUTER	DELL	PP05L	16484462992	E2K24CLNS
2	PRINTER	EPSON	LQ-300+	DCGY054147	FCC DoC Approved
3	MODEM	ACEEX	1414V/3	0401008269	IFAXDM1414
4	NOTEBOOK COMPUTER	DELL	PP05L	12130898320	E2K24CLNS

NO.	SIGNAL CABLE DESCRIPTION OF THE ABOVE SUPPORT UNITS
1	3.0m UTP RJ45 cable
2	1.2m braid shielded wire, DB25 & DB9 connector, w/o core.
3	1.8m braid shielded wire, DB25 connector, w/o core.
4	10.0m UTP RJ45 cable

NOTE 1: All power cords of the above support units are non shielded (1.8m).

NOTE 2: Item 4 acted as communication partners to transfer data.

4. TEST TYPES AND RESULTS

4.1 RADIATED EMISSION MEASUREMENT

4.1.1 LIMITS OF RADIATED EMISSION MEASUREMENT

Emissions radiated outside of the specified bands, shall be according to the general radiated limits in 15.209 as following:

FREQUENCIES (MHz)	FIELD STRENGTH (microvolts/meter)	MEASUREMENT DISTANCE (meters)
0.009 ~ 0.490	2400/F(kHz)	300
0.490 ~ 1.705	24000/F(kHz)	30
1.705 ~ 30.0	30	30
30 ~ 88	100	3
88 ~ 216	150	3
216 ~ 960	200	3
Above 960	500	3

NOTE:

1. The lower limit shall apply at the transition frequencies.
2. Emission level (dBuV/m) = 20 log Emission level (uV/m).
3. As shown in 15.35(b), for frequencies above 1000MHz, the field strength limits are based on average detector, however, the peak field strength of any emission shall not exceed the maximum permitted average limits, specified above by more than 20dB under any condition of modulation.

4.1.2 LIMITS OF UNWANTED EMISSION OUT OF THE RESTRICTED BANDS

FREQUENCIES (MHz)	EIRP LIMIT (dBm)	EQUIVALENT FIELD STRENGTH AT 3m (dBµV/m) *NOTE
	PK	PK
5250 ~ 5350	-27	68.3
5470 ~ 5725	-27	68.3

NOTE:

The following formula is used to convert the equipment isotropic radiated power (eirp) to field strength:

$$E = \frac{1000000\sqrt{30P}}{3} \mu\text{V/m, where P is the eirp (Watts).}$$

4.1.3 TEST INSTRUMENTS

DESCRIPTION & MANUFACTURER	MODEL NO.	SERIAL NO.	DATE OF CALIBRATION	DUE DATE OF CALIBRATION
Test Receiver ROHDE & SCHWARZ	ESCI	100424	Jul. 28, 2007	Jul. 27, 2008
Spectrum Analyzer ROHDE & SCHWARZ	FSP40	100269	Aug. 06, 2007	Aug. 05, 2008
BILOG Antenna SCHWARZBECK	VULB9168	9168-153	Jan. 04, 2008	Jan. 03, 2009
HORN Antenna SCHWARZBECK	BBHA 9120 D	9120D-563	Jul. 31, 2007	Jul. 30, 2008
HORN Antenna SCHWARZBECK	BBHA 9170	BBHA9170242	Jan. 07, 2008	Jan. 06, 2009
Preamplifier Agilent	8449B	3008A01910	Sep. 20, 2007	Sep. 19, 2008
Preamplifier Agilent	8447D	2944A10638	Dec. 20, 2007	Dec. 19, 2008
RF signal cable HUBER+SUHNNER	SUCOFLEX 104	274039/223650	Nov. 08, 2007	Nov. 07, 2008
RF signal cable Worken	8D-FB	Cable-HYCH9-01	Aug. 10, 2007	Aug. 09, 2008
Software	ADT_Radiated_V7.6	NA	NA	NA
Antenna Tower EMCO	2070/2080	512.835.4684	NA	NA
Turn Table EMCO	2087-2.03	NA	NA	NA
Antenna Tower & Turn Table Controller EMCO	2090	NA	NA	NA
26GHz ~ 40GHz Amplifier	EM26400	07026401	Apr. 23, 2008	Apr. 22, 2009

- NOTE:**
1. The calibration interval of the above test instruments is 12 months and the calibrations are traceable to NML/ROC and NIST/USA.
 2. The test was performed in HwaYa Chamber 9.
 3. The horn antenna and HP preamplifier (model: 8449B) are used only for the measurement of emission frequency above 1GHz if tested.
 4. The FCC Site Registration No. is 460141.
 5. The IC Site Registration No. is IC 7450F-4.

4.1.4 TEST PROCEDURES

- a. The EUT was placed on the top of a rotating table 0.8 meters above the ground at a 3 meter semi-anechoic chamber. The table was rotated 360 degrees to determine the position of the highest radiation.
- b. The EUT was set 3 meters away from the interference-receiving antenna, which was mounted on the top of a variable-height antenna tower.
- c. The antenna is a broadband antenna, and its height is varied from one meter to four meters above the ground to determine the maximum value of the field strength. Both horizontal and vertical polarizations of the antenna are set to make the measurement.
- d. For each suspected emission, the EUT was arranged to its worst case and then the antenna was tuned to heights from 1 meter to 4 meters and the rotatable table was turned from 0 degrees to 360 degrees to find the maximum reading.
- e. The test-receiver system was set to Peak Detect Function and Specified Bandwidth with Maximum Hold Mode.
- f. If the emission level of the EUT in peak mode was 10dB lower than the limit specified, then testing could be stopped and the peak values of the EUT would be reported. Otherwise the emissions that did not have 10dB margin would be re-tested one by one using peak, quasi-peak or average method as specified and then reported in a data sheet.

NOTE:

1. The resolution bandwidth and video bandwidth of test receiver/spectrum analyzer is 120kHz for Peak detection (PK) and Quasi-peak detection (QP) at frequency below 1GHz.
2. The resolution bandwidth of test receiver/spectrum analyzer is 1MHz and video bandwidth is 3MHz for Peak detection at frequency above 1GHz.
3. The resolution bandwidth of test receiver/spectrum analyzer is 1MHz and the video bandwidth is 10Hz for Average detection (AV) at frequency above 1GHz.
4. All modes of operation were investigated and the worst-case emissions are reported.

4.1.5 DEVIATION FROM TEST STANDARD

No deviation

4.1.6 TEST SETUP

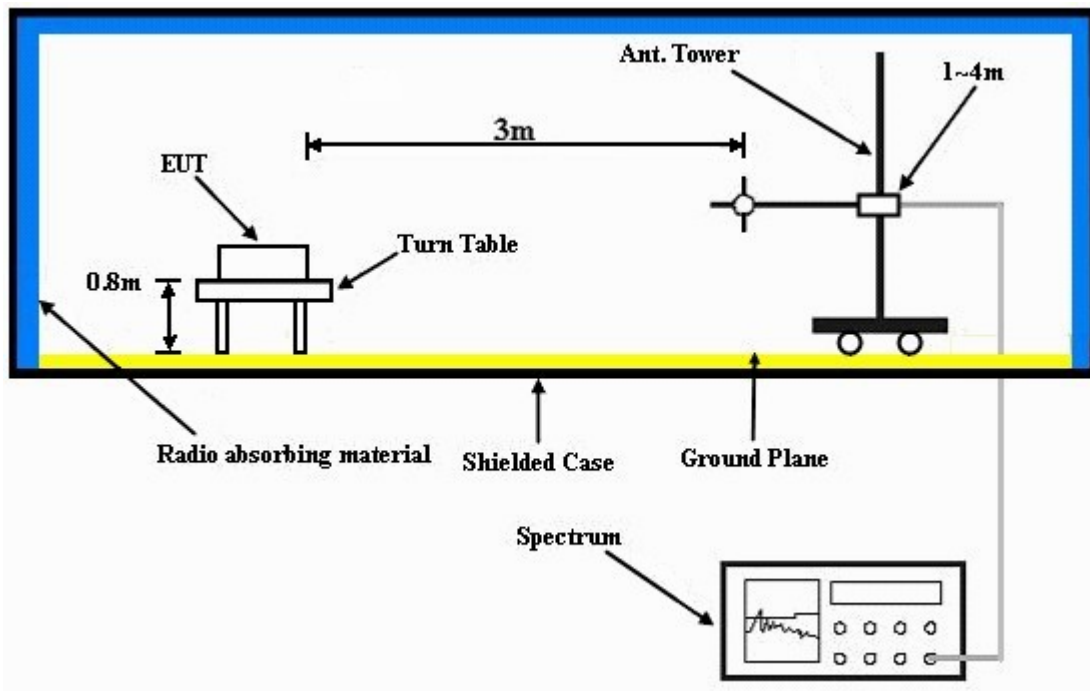

For the actual test configuration, please refer to the attached file (Test Setup Photo).

4.1.7 EUT OPERATING CONDITION

- Placed the EUT on the testing table.
- The necessary accessories enable the system in full functions.
- Prepared the other notebook outside of testing area to act as a communication partner.
- The communication partner connected with EUT via a UTP cable and run a test program (provided by manufacturer) to enable EUT under transmission condition continuously at specific channel frequency.
- The communication partner sent data to EUT by command "PING".

4.1.8 TEST RESULTS

802.11a OFDM MODULATION

EUT TEST CONDITION		MEASUREMENT DETAIL	
CHANNEL	Channel 52	FREQUENCY RANGE	1 ~ 40GHz
INPUT POWER (SYSTEM)	120Vac, 60 Hz	DETECTOR FUNCTION	Peak (PK) Average (AV)
ENVIRONMENTAL CONDITIONS	24deg. C, 70%RH 998hPa	TESTED BY	Brad Wu

ANTENNA POLARITY & TEST DISTANCE: HORIZONTAL AT 3 M								
NO.	FREQ. (MHz)	EMISSION LEVEL (dBuV/m)	LIMIT (dBuV/m)	MARGIN (dB)	ANTENNA HEIGHT (m)	TABLE ANGLE (Degree)	RAW VALUE (dBuV)	CORRECTION FACTOR (dB/m)
1	5150.00	51.37 PK	74.00	-22.63	1.02 H	281	12.29	39.08
2	5150.00	39.28 AV	54.00	-14.72	1.02 H	281	0.20	39.08
3	*5260.00	99.44 PK			1.02 H	281	60.22	39.22
4	*5260.00	87.16 AV			1.02 H	281	47.94	39.22
5	#7013.00	53.22 PK	68.30	-15.08	1.29 H	42	8.91	44.31
6	#10520.00	57.65 PK	68.30	-10.65	1.09 H	238	7.70	49.95
ANTENNA POLARITY & TEST DISTANCE: VERTICAL AT 3 M								
NO.	FREQ. (MHz)	EMISSION LEVEL (dBuV/m)	LIMIT (dBuV/m)	MARGIN (dB)	ANTENNA HEIGHT (m)	TABLE ANGLE (Degree)	RAW VALUE (dBuV)	CORRECTION FACTOR (dB/m)
1	5150.00	51.43 PK	74.00	-22.57	1.02 V	204	12.35	39.08
2	5150.00	39.61 AV	54.00	-14.39	1.02 V	204	0.53	39.08
3	*5260.00	111.61 PK			1.02 V	204	72.39	39.22
4	*5260.00	100.76 AV			1.02 V	204	61.54	39.22
5	#7013.00	56.23 PK	68.30	-12.07	1.42 V	305	11.92	44.31
6	#10520.00	58.65 PK	68.30	-9.65	1.02 V	38	8.70	49.95

- REMARKS:**
1. Emission level (dBuV/m) = Raw Value (dBuV) + Correction Factor (dB/m).
 2. Correction Factor (dB/m) = Antenna Factor (dB/m) + Cable Factor (dB).
 3. The other emission levels were very low against the limit.
 4. Margin value = Emission level – Limit value.
 5. “ * “: Fundamental frequency.
 6. “#”: The radiated frequency is out the restricted band.



A D T

EUT TEST CONDITION		MEASUREMENT DETAIL	
CHANNEL	Channel 60	FREQUENCY RANGE	1 ~ 40GHz
INPUT POWER (SYSTEM)	120Vac, 60 Hz	DETECTOR FUNCTION	Peak (PK) Average (AV)
ENVIRONMENTAL CONDITIONS	24deg. C, 70%RH 998hPa	TESTED BY	Brad Wu

ANTENNA POLARITY & TEST DISTANCE: HORIZONTAL AT 3 M								
NO.	FREQ. (MHz)	EMISSION LEVEL (dBuV/m)	LIMIT (dBuV/m)	MARGIN (dB)	ANTENNA HEIGHT (m)	TABLE ANGLE (Degree)	RAW VALUE (dBuV)	CORRECTION FACTOR (dB/m)
1	*5300.00	99.31 PK			1.05 H	302	60.05	39.26
2	*5300.00	86.94 AV			1.05 H	302	47.68	39.26
3	#7066.00	53.56 PK	68.30	-14.74	1.18 H	58	8.94	44.62
4	10600.00	58.15 PK	74.00	-15.85	1.06 H	219	8.02	50.13
5	10600.00	44.96 AV	54.00	-9.04	1.06 H	219	-5.17	50.13
ANTENNA POLARITY & TEST DISTANCE: VERTICAL AT 3 M								
NO.	FREQ. (MHz)	EMISSION LEVEL (dBuV/m)	LIMIT (dBuV/m)	MARGIN (dB)	ANTENNA HEIGHT (m)	TABLE ANGLE (Degree)	RAW VALUE (dBuV)	CORRECTION FACTOR (dB/m)
1	*5300.00	111.22 PK			1.09 V	49	71.96	39.26
2	*5300.00	100.46 AV			1.09 V	49	61.20	39.26
3	#7066.00	56.45 PK	68.30	-11.85	1.39 V	295	11.83	44.62
4	10600.00	58.64 PK	74.00	-15.36	1.09 V	56	8.51	50.13
5	10600.00	45.61 AV	54.00	-8.39	1.09 V	56	-4.52	50.13

- REMARKS:**
1. Emission level (dBuV/m) = Raw Value (dBuV) + Correction Factor (dB/m).
 2. Correction Factor (dB/m) = Antenna Factor (dB/m) + Cable Factor (dB).
 3. The other emission levels were very low against the limit.
 4. Margin value = Emission level – Limit value.
 5. “ * “: Fundamental frequency.
 6. “#”:The radiated frequency is out the restricted band.



A D T

EUT TEST CONDITION		MEASUREMENT DETAIL	
CHANNEL	Channel 64	FREQUENCY RANGE	1 ~ 40GHz
INPUT POWER (SYSTEM)	120Vac, 60 Hz	DETECTOR FUNCTION	Peak (PK) Average (AV)
ENVIRONMENTAL CONDITIONS	24deg. C, 70%RH 998hPa	TESTED BY	Match Tsui

ANTENNA POLARITY & TEST DISTANCE: HORIZONTAL AT 3 M								
NO.	FREQ. (MHz)	EMISSION LEVEL (dBuV/m)	LIMIT (dBuV/m)	MARGIN (dB)	ANTENNA HEIGHT (m)	TABLE ANGLE (Degree)	RAW VALUE (dBuV)	CORRECTION FACTOR (dB/m)
1	*5320.00	99.21 PK			1.05 H	220	59.93	39.28
2	*5320.00	87.39 AV			1.05 H	220	48.11	39.28
3	5350.00	54.36 PK	74.00	-19.64	1.05 H	220	15.05	39.31
4	5350.00	38.66 AV	54.00	-15.34	1.05 H	220	-0.65	39.31
5	#7093.00	54.68 PK	68.30	-13.62	1.35 H	202	9.91	44.77
6	10640.00	57.38 PK	74.00	-16.62	1.01 H	13	7.21	50.17
7	10640.00	44.42 AV	54.00	-9.58	1.01 H	13	-5.75	50.17
ANTENNA POLARITY & TEST DISTANCE: VERTICAL AT 3 M								
NO.	FREQ. (MHz)	EMISSION LEVEL (dBuV/m)	LIMIT (dBuV/m)	MARGIN (dB)	ANTENNA HEIGHT (m)	TABLE ANGLE (Degree)	RAW VALUE (dBuV)	CORRECTION FACTOR (dB/m)
1	*5320.00	111.01 PK			1.20 V	36	71.73	39.28
2	*5320.00	100.22 AV			1.20 V	36	60.94	39.28
3	5350.00	62.05 PK	74.00	-11.95	1.20 V	360	22.74	39.31
4	5350.00	41.58 AV	54.00	-12.42	1.20 V	360	2.27	39.31
5	#7093.00	56.29 PK	68.30	-12.01	1.55 V	83	11.52	44.77
6	10640.00	58.52 PK	74.00	-15.48	1.52 V	0	8.36	50.17
7	10640.00	45.49 AV	54.00	-8.51	1.52 V	0	-4.67	50.17

- REMARKS:**
1. Emission level (dBuV/m) = Raw Value (dBuV) + Correction Factor (dB/m).
 2. Correction Factor (dB/m) = Antenna Factor (dB/m) + Cable Factor (dB).
 3. The other emission levels were very low against the limit.
 4. Margin value = Emission level – Limit value.
 5. “ * “: Fundamental frequency.
 6. “#”:The radiated frequency is out the restricted band.



A D T

EUT TEST CONDITION		MEASUREMENT DETAIL	
CHANNEL	Channel 100	FREQUENCY RANGE	1 ~ 40GHz
INPUT POWER (SYSTEM)	120Vac, 60 Hz	DETECTOR FUNCTION	Peak (PK) Average (AV)
ENVIRONMENTAL CONDITIONS	24deg. C, 70%RH 999hPa	TESTED BY	Mitch Tsui

ANTENNA POLARITY & TEST DISTANCE: HORIZONTAL AT 3 M								
NO.	FREQ. (MHz)	EMISSION LEVEL (dBuV/m)	LIMIT (dBuV/m)	MARGIN (dB)	ANTENNA HEIGHT (m)	TABLE ANGLE (Degree)	RAW VALUE (dBuV)	CORRECTION FACTOR (dB/m)
1	5460.00	43.61 PK	74.00	-30.39	1.06 H	213	4.12	39.49
2	5460.00	31.86 AV	54.00	-22.14	1.06 H	213	-7.63	39.49
3	#5470.00	51.53 PK	68.30	-16.77	1.06 H	213	12.01	39.52
4	*5500.00	98.94 PK			1.06 H	213	59.35	39.59
5	*5500.00	87.14 AV			1.06 H	213	47.55	39.59
6	7333.00	55.12 PK	74.00	-18.88	1.28 H	194	9.54	45.58
7	7333.00	48.06 AV	54.00	-5.94	1.28 H	194	2.48	45.58
8	11000.00	57.66 PK	74.00	-16.34	1.04 H	234	6.91	50.75
9	11000.00	44.69 AV	54.00	-9.31	1.04 H	234	-6.06	50.75
ANTENNA POLARITY & TEST DISTANCE: VERTICAL AT 3 M								
NO.	FREQ. (MHz)	EMISSION LEVEL (dBuV/m)	LIMIT (dBuV/m)	MARGIN (dB)	ANTENNA HEIGHT (m)	TABLE ANGLE (Degree)	RAW VALUE (dBuV)	CORRECTION FACTOR (dB/m)
1	5460.00	53.76 PK	74.00	-20.24	1.17 V	230	14.26	39.49
2	5460.00	41.92 AV	54.00	-12.08	1.17 V	230	2.42	39.49
3	#5470.00	61.64 PK	68.30	-6.66	1.17 V	230	22.12	39.52
4	*5500.00	111.32 PK			1.17 V	230	71.73	39.59
5	*5500.00	100.40 AV			1.17 V	230	60.82	39.59
6	7333.00	55.50 PK	74.00	-18.50	1.64 V	129	9.92	45.58
7	7333.00	47.77 AV	54.00	-6.23	1.64 V	129	2.19	45.58
8	11000.00	58.86 PK	74.00	-15.14	1.00 V	360	8.11	50.75
9	11000.00	45.54 AV	54.00	-8.46	1.00 V	360	-5.21	50.75

- REMARKS:**
1. Emission level (dBuV/m) = Raw Value (dBuV) + Correction Factor (dB/m).
 2. Correction Factor (dB/m) = Antenna Factor (dB/m) + Cable Factor (dB).
 3. The other emission levels were very low against the limit.
 4. Margin value = Emission level – Limit value.
 5. “ * “: Fundamental frequency.
 6. “#”:The radiated frequency is out the restricted band.



A D T

EUT TEST CONDITION		MEASUREMENT DETAIL	
CHANNEL	Channel 120	FREQUENCY RANGE	1 ~ 40GHz
INPUT POWER (SYSTEM)	120Vac, 60 Hz	DETECTOR FUNCTION	Peak (PK) Average (AV)
ENVIRONMENTAL CONDITIONS	24deg. C, 70%RH 998hPa	TESTED BY	Match Tsui

ANTENNA POLARITY & TEST DISTANCE: HORIZONTAL AT 3 M								
NO.	FREQ. (MHz)	EMISSION LEVEL (dBuV/m)	LIMIT (dBuV/m)	MARGIN (dB)	ANTENNA HEIGHT (m)	TABLE ANGLE (Degree)	RAW VALUE (dBuV)	CORRECTION FACTOR (dB/m)
1	*5600.00	98.84 PK			1.09 H	216	59.04	39.80
2	*5600.00	87.05 AV			1.09 H	216	47.25	39.80
3	7466.00	54.23 PK	74.00	-19.77	1.21 H	53	8.62	45.61
4	7466.00	46.52 AV	54.00	-7.48	1.21 H	53	0.91	45.61
5	11200.00	57.95 PK	74.00	-16.05	1.13 H	245	7.30	50.65
6	11200.00	44.78 AV	54.00	-9.22	1.13 H	245	-5.87	50.65
ANTENNA POLARITY & TEST DISTANCE: VERTICAL AT 3 M								
NO.	FREQ. (MHz)	EMISSION LEVEL (dBuV/m)	LIMIT (dBuV/m)	MARGIN (dB)	ANTENNA HEIGHT (m)	TABLE ANGLE (Degree)	RAW VALUE (dBuV)	CORRECTION FACTOR (dB/m)
1	*5600.00	110.84 PK			1.15 V	238	71.04	39.80
2	*5600.00	100.00 AV			1.15 V	238	60.20	39.80
3	7466.00	55.84 PK	74.00	-18.16	1.31 V	249	10.23	45.61
4	7466.00	48.04 AV	54.00	-5.96	1.31 V	249	2.43	45.61
5	11200.00	58.99 PK	74.00	-15.01	1.01 V	23	8.34	50.65
6	11200.00	45.67 AV	54.00	-8.33	1.01 V	23	-4.98	50.65

- REMARKS:**
1. Emission level (dBuV/m) = Raw Value (dBuV) + Correction Factor (dB/m).
 2. Correction Factor (dB/m) = Antenna Factor (dB/m) + Cable Factor (dB).
 3. The other emission levels were very low against the limit.
 4. Margin value = Emission level – Limit value.
 5. “ * “: Fundamental frequency.



A D T

EUT TEST CONDITION		MEASUREMENT DETAIL	
CHANNEL	Channel 140	FREQUENCY RANGE	1 ~ 40GHz
INPUT POWER (SYSTEM)	120Vac, 60 Hz	DETECTOR FUNCTION	Peak (PK) Average (AV)
ENVIRONMENTAL CONDITIONS	24deg. C, 70%RH 999hPa	TESTED BY	Mitch Tsui

ANTENNA POLARITY & TEST DISTANCE: HORIZONTAL AT 3 M								
NO.	FREQ. (MHz)	EMISSION LEVEL (dBuV/m)	LIMIT (dBuV/m)	MARGIN (dB)	ANTENNA HEIGHT (m)	TABLE ANGLE (Degree)	RAW VALUE (dBuV)	CORRECTION FACTOR (dB/m)
1	*5700.00	99.10 PK			1.10 H	219	59.03	40.07
2	*5700.00	87.32 AV			1.10 H	219	47.25	40.07
3	#5725.00	60.56 PK	68.30	-7.74	1.10 H	219	20.43	40.13
4	7600.00	54.69 PK	74.00	-19.31	1.28 H	64	9.16	45.53
5	7600.00	46.95 AV	54.00	-7.05	1.28 H	64	1.42	45.53
6	11400.00	58.14 PK	74.00	-15.86	1.01 H	236	7.40	50.74
7	11400.00	44.95 AV	54.00	-9.05	1.01 H	236	-5.79	50.74
ANTENNA POLARITY & TEST DISTANCE: VERTICAL AT 3 M								
NO.	FREQ. (MHz)	EMISSION LEVEL (dBuV/m)	LIMIT (dBuV/m)	MARGIN (dB)	ANTENNA HEIGHT (m)	TABLE ANGLE (Degree)	RAW VALUE (dBuV)	CORRECTION FACTOR (dB/m)
1	*5700.00	110.90 PK			1.49 V	164	70.83	40.07
2	*5700.00	99.53 AV			1.49 V	164	59.47	40.07
3	#5725.00	67.26 PK	68.30	-1.04	1.49 V	164	27.13	40.13
4	7600.00	58.71 PK	74.00	-15.29	1.45 V	290	13.18	45.53
5	7600.00	48.70 AV	54.00	-5.30	1.45 V	290	3.17	45.53
6	11400.00	58.73 PK	74.00	-15.27	1.37 V	1	7.99	50.74
7	11400.00	45.92 AV	54.00	-8.08	1.37 V	1	-4.82	50.74

- REMARKS:**
1. Emission level (dBuV/m) = Raw Value (dBuV) + Correction Factor (dB/m).
 2. Correction Factor (dB/m) = Antenna Factor (dB/m) + Cable Factor (dB).
 3. The other emission levels were very low against the limit.
 4. Margin value = Emission level – Limit value.
 5. “ * “: Fundamental frequency.
 6. “#”:The radiated frequency is out the restricted band.



A D T

DRAFT 802.11n (20MHz) OFDM MODULATION

EUT TEST CONDITION		MEASUREMENT DETAIL	
CHANNEL	Channel 52	FREQUENCY RANGE	1 ~ 40GHz
INPUT POWER (SYSTEM)	120Vac, 60 Hz	DETECTOR FUNCTION	Peak (PK) Average (AV)
ENVIRONMENTAL CONDITIONS	24deg. C, 70%RH 998hPa	TESTED BY	Lori Chiu

ANTENNA POLARITY & TEST DISTANCE: HORIZONTAL AT 3 M								
NO.	FREQ. (MHz)	EMISSION LEVEL (dBuV/m)	LIMIT (dBuV/m)	MARGIN (dB)	ANTENNA HEIGHT (m)	TABLE ANGLE (Degree)	RAW VALUE (dBuV)	CORRECTION FACTOR (dB/m)
1	5150.00	51.32 PK	74.00	-22.68	1.05 H	285	12.24	39.08
2	5150.00	39.42 AV	54.00	-14.58	1.05 H	285	0.34	39.08
3	*5260.00	98.73 PK			1.05 H	285	59.51	39.22
4	*5260.00	87.59 AV			1.05 H	285	48.37	39.22
5	#7013.00	51.29 PK	68.30	-17.01	1.03 H	271	6.97	44.31
6	#10520.00	58.76 PK	68.30	-9.54	1.24 H	27	8.81	49.95

ANTENNA POLARITY & TEST DISTANCE: VERTICAL AT 3 M								
NO.	FREQ. (MHz)	EMISSION LEVEL (dBuV/m)	LIMIT (dBuV/m)	MARGIN (dB)	ANTENNA HEIGHT (m)	TABLE ANGLE (Degree)	RAW VALUE (dBuV)	CORRECTION FACTOR (dB/m)
1	5150.00	51.41 PK	74.00	-22.59	1.00 V	214	12.33	39.08
2	5150.00	39.55 AV	54.00	-14.45	1.00 V	214	0.47	39.08
3	*5260.00	112.36 PK			1.00 V	214	73.14	39.22
4	*5260.00	101.76 AV			1.00 V	214	62.54	39.22
5	#7013.00	53.64 PK	68.30	-14.66	1.59 V	43	9.32	44.31
6	#10520.00	58.81 PK	68.30	-9.49	1.30 V	228	8.87	49.95

- REMARKS:**
1. Emission level (dBuV/m) = Raw Value (dBuV) + Correction Factor (dB/m).
 2. Correction Factor (dB/m) = Antenna Factor (dB/m) + Cable Factor (dB).
 3. The other emission levels were very low against the limit.
 4. Margin value = Emission level – Limit value.
 5. “ * “: Fundamental frequency.
 6. “#“: The radiated frequency is out the restricted band.



A D T

EUT TEST CONDITION		MEASUREMENT DETAIL	
CHANNEL	Channel 60	FREQUENCY RANGE	1 ~ 40GHz
INPUT POWER (SYSTEM)	120Vac, 60 Hz	DETECTOR FUNCTION	Peak (PK) Average (AV)
ENVIRONMENTAL CONDITIONS	24deg. C, 70%RH 998hPa	TESTED BY	Lori Chiu

ANTENNA POLARITY & TEST DISTANCE: HORIZONTAL AT 3 M								
NO.	FREQ. (MHz)	EMISSION LEVEL (dBuV/m)	LIMIT (dBuV/m)	MARGIN (dB)	ANTENNA HEIGHT (m)	TABLE ANGLE (Degree)	RAW VALUE (dBuV)	CORRECTION FACTOR (dB/m)
1	*5300.00	98.15 PK			1.00 H	280	58.89	39.26
2	*5300.00	87.43 AV			1.00 H	280	48.17	39.26
3	#7067.00	51.64 PK	68.30	-16.66	1.03 H	124	7.01	44.62
4	10600.00	58.20 PK	74.00	-15.80	1.14 H	5	8.07	50.13
5	10600.00	44.24 AV	54.00	-9.76	1.14 H	5	-5.89	50.13
ANTENNA POLARITY & TEST DISTANCE: VERTICAL AT 3 M								
NO.	FREQ. (MHz)	EMISSION LEVEL (dBuV/m)	LIMIT (dBuV/m)	MARGIN (dB)	ANTENNA HEIGHT (m)	TABLE ANGLE (Degree)	RAW VALUE (dBuV)	CORRECTION FACTOR (dB/m)
1	*5300.00	112.13 PK			1.20 V	33	72.87	39.26
2	*5300.00	101.34 AV			1.20 V	33	62.08	39.26
3	#7067.00	53.41 PK	68.30	-14.89	1.57 V	44	8.78	44.62
4	10600.00	58.44 PK	74.00	-15.56	1.23 V	342	8.31	50.13
5	10600.00	44.66 AV	54.00	-9.34	1.23 V	342	-5.47	50.13

- REMARKS:**
1. Emission level (dBuV/m) = Raw Value (dBuV) + Correction Factor (dB/m).
 2. Correction Factor (dB/m) = Antenna Factor (dB/m) + Cable Factor (dB).
 3. The other emission levels were very low against the limit.
 4. Margin value = Emission level – Limit value.
 5. “ * “: Fundamental frequency.
 6. “#”:The radiated frequency is out the restricted band.



A D T

EUT TEST CONDITION		MEASUREMENT DETAIL	
CHANNEL	Channel 64	FREQUENCY RANGE	1 ~ 40GHz
INPUT POWER (SYSTEM)	120Vac, 60 Hz	DETECTOR FUNCTION	Peak (PK) Average (AV)
ENVIRONMENTAL CONDITIONS	24deg. C, 70%RH 998hPa	TESTED BY	Lori Chiu

ANTENNA POLARITY & TEST DISTANCE: HORIZONTAL AT 3 M								
NO.	FREQ. (MHz)	EMISSION LEVEL (dBuV/m)	LIMIT (dBuV/m)	MARGIN (dB)	ANTENNA HEIGHT (m)	TABLE ANGLE (Degree)	RAW VALUE (dBuV)	CORRECTION FACTOR (dB/m)
1	*5320.00	98.71 PK			1.03 H	225	59.43	39.28
2	*5320.00	87.55 AV			1.03 H	225	48.27	39.28
3	5350.00	57.08 PK	74.00	-16.92	1.03 H	225	17.77	39.31
4	5350.00	44.62 AV	54.00	-9.38	1.03 H	225	5.31	39.31
5	#7093.00	53.42 PK	68.30	-14.88	1.10 H	180	8.65	44.77
6	10640.00	57.65 PK	74.00	-16.35	1.06 H	5	7.48	50.17
7	10640.00	44.37 AV	54.00	-9.63	1.06 H	5	-5.80	50.17
ANTENNA POLARITY & TEST DISTANCE: VERTICAL AT 3 M								
NO.	FREQ. (MHz)	EMISSION LEVEL (dBuV/m)	LIMIT (dBuV/m)	MARGIN (dB)	ANTENNA HEIGHT (m)	TABLE ANGLE (Degree)	RAW VALUE (dBuV)	CORRECTION FACTOR (dB/m)
1	*5320.00	112.40 PK			1.40 V	114	73.12	39.28
2	*5320.00	101.64 AV			1.40 V	114	62.36	39.28
3	5350.00	57.12 PK	74.00	-16.88	1.40 V	114	17.81	39.31
4	5350.00	44.85 AV	54.00	-9.15	1.40 V	114	5.54	39.31
5	#7093.00	54.29 PK	68.30	-14.01	1.67 V	46	9.52	44.77
6	10640.00	57.70 PK	74.00	-16.30	1.15 V	67	7.54	50.17
7	10640.00	44.62 AV	54.00	-9.38	1.15 V	67	-5.54	50.17

- REMARKS:**
1. Emission level (dBuV/m) = Raw Value (dBuV) + Correction Factor (dB/m).
 2. Correction Factor (dB/m) = Antenna Factor (dB/m) + Cable Factor (dB).
 3. The other emission levels were very low against the limit.
 4. Margin value = Emission level – Limit value.
 5. “ * “: Fundamental frequency.
 6. “#”:The radiated frequency is out the restricted band.



A D T

EUT TEST CONDITION		MEASUREMENT DETAIL	
CHANNEL	Channel 100	FREQUENCY RANGE	1 ~ 40GHz
INPUT POWER (SYSTEM)	120Vac, 60 Hz	DETECTOR FUNCTION	Peak (PK) Average (AV)
ENVIRONMENTAL CONDITIONS	24deg. C, 70%RH 998hPa	TESTED BY	Lori Chiu

ANTENNA POLARITY & TEST DISTANCE: HORIZONTAL AT 3 M								
NO.	FREQ. (MHz)	EMISSION LEVEL (dBuV/m)	LIMIT (dBuV/m)	MARGIN (dB)	ANTENNA HEIGHT (m)	TABLE ANGLE (Degree)	RAW VALUE (dBuV)	CORRECTION FACTOR (dB/m)
1	5460.00	56.39 PK	74.00	-17.61	1.10 H	203	16.90	39.49
2	5460.00	44.71 AV	54.00	-9.29	1.10 H	203	5.22	39.49
3	#5470.00	56.52 PK	68.30	-11.78	1.10 H	203	17.00	39.52
4	*5500.00	97.75 PK			1.10 H	203	58.16	39.59
5	*5500.00	86.89 AV			1.10 H	203	47.30	39.59
6	7333.00	52.32 PK	74.00	-21.68	1.21 H	17	6.74	45.58
7	7333.00	39.78 AV	54.00	-14.22	1.21 H	17	-5.80	45.58
8	11000.00	58.98 PK	74.00	-15.02	1.25 H	324	8.23	50.75
9	11000.00	45.17 AV	54.00	-8.83	1.25 H	324	-5.58	50.75
ANTENNA POLARITY & TEST DISTANCE: VERTICAL AT 3 M								
NO.	FREQ. (MHz)	EMISSION LEVEL (dBuV/m)	LIMIT (dBuV/m)	MARGIN (dB)	ANTENNA HEIGHT (m)	TABLE ANGLE (Degree)	RAW VALUE (dBuV)	CORRECTION FACTOR (dB/m)
1	5460.00	56.46 PK	74.00	-17.54	1.12 V	39	16.96	39.49
2	5460.00	44.76 AV	54.00	-9.24	1.12 V	39	5.26	39.49
3	#5470.00	56.95 PK	68.30	-11.35	1.13 V	40	17.43	39.52
4	*5500.00	110.44 PK			1.13 V	39	70.86	39.59
5	*5500.00	99.80 AV			1.13 V	39	60.21	39.59
6	7333.00	54.49 PK	74.00	-19.51	1.57 V	88	8.91	45.58
7	7333.00	45.93 AV	54.00	-8.07	1.57 V	88	0.35	45.58
8	11000.00	59.15 PK	74.00	-14.85	1.08 V	55	8.40	50.75
9	11000.00	45.40 AV	54.00	-8.60	1.08 V	55	-5.35	50.75

- REMARKS:**
1. Emission level (dBuV/m) = Raw Value (dBuV) + Correction Factor (dB/m).
 2. Correction Factor (dB/m) = Antenna Factor (dB/m) + Cable Factor (dB).
 3. The other emission levels were very low against the limit.
 4. Margin value = Emission level – Limit value.
 5. “ * “: Fundamental frequency.
 6. “#”:The radiated frequency is out the restricted band.



A D T

EUT TEST CONDITION		MEASUREMENT DETAIL	
CHANNEL	Channel 120	FREQUENCY RANGE	1 ~ 40GHz
INPUT POWER (SYSTEM)	120Vac, 60 Hz	DETECTOR FUNCTION	Peak (PK) Average (AV)
ENVIRONMENTAL CONDITIONS	24deg. C, 70%RH 998hPa	TESTED BY	Lori Chiu

ANTENNA POLARITY & TEST DISTANCE: HORIZONTAL AT 3 M								
NO.	FREQ. (MHz)	EMISSION LEVEL (dBuV/m)	LIMIT (dBuV/m)	MARGIN (dB)	ANTENNA HEIGHT (m)	TABLE ANGLE (Degree)	RAW VALUE (dBuV)	CORRECTION FACTOR (dB/m)
1	*5600.00	97.86 PK			1.06 H	221	58.06	39.80
2	*5600.00	87.09 AV			1.06 H	221	47.29	39.80
3	7466.00	55.91 PK	74.00	-18.09	1.28 H	249	10.30	45.61
4	7466.00	45.55 AV	54.00	-8.45	1.28 H	249	-0.06	45.61
5	11200.00	59.13 PK	74.00	-14.87	1.00 H	237	8.48	50.65
6	11200.00	46.09 AV	54.00	-7.91	1.00 H	237	-4.56	50.65
ANTENNA POLARITY & TEST DISTANCE: VERTICAL AT 3 M								
NO.	FREQ. (MHz)	EMISSION LEVEL (dBuV/m)	LIMIT (dBuV/m)	MARGIN (dB)	ANTENNA HEIGHT (m)	TABLE ANGLE (Degree)	RAW VALUE (dBuV)	CORRECTION FACTOR (dB/m)
1	*5600.00	110.76 PK			1.11 V	47	70.96	39.80
2	*5600.00	100.06 AV			1.11 V	47	60.26	39.80
3	7466.00	57.85 PK	74.00	-16.15	1.08 V	0	12.24	45.61
4	7466.00	51.94 AV	54.00	-2.06	1.08 V	0	6.33	45.61
5	11200.00	59.23 PK	74.00	-14.77	1.23 V	328	8.58	50.65
6	11200.00	46.14 AV	54.00	-7.86	1.23 V	328	-4.51	50.65

- REMARKS:**
1. Emission level (dBuV/m) = Raw Value (dBuV) + Correction Factor (dB/m).
 2. Correction Factor (dB/m) = Antenna Factor (dB/m) + Cable Factor (dB).
 3. The other emission levels were very low against the limit.
 4. Margin value = Emission level – Limit value.
 5. “ * “: Fundamental frequency.



A D T

EUT TEST CONDITION		MEASUREMENT DETAIL	
CHANNEL	Channel 140	FREQUENCY RANGE	1 ~ 40GHz
INPUT POWER (SYSTEM)	120Vac, 60 Hz	DETECTOR FUNCTION	Peak (PK) Average (AV)
ENVIRONMENTAL CONDITIONS	24deg. C, 70%RH 998hPa	TESTED BY	Lori Chiu

ANTENNA POLARITY & TEST DISTANCE: HORIZONTAL AT 3 M								
NO.	FREQ. (MHz)	EMISSION LEVEL (dBuV/m)	LIMIT (dBuV/m)	MARGIN (dB)	ANTENNA HEIGHT (m)	TABLE ANGLE (Degree)	RAW VALUE (dBuV)	CORRECTION FACTOR (dB/m)
1	*5700.00	97.72 PK			1.05 H	235	57.65	40.07
2	*5700.00	87.63 AV			1.05 H	235	47.56	40.07
3	#5725.00	60.02 PK	68.30	-8.28	1.05 H	235	19.89	40.13
4	7600.00	53.07 PK	74.00	-20.93	1.36 H	288	7.54	45.53
5	7600.00	41.87 AV	54.00	-12.13	1.36 H	288	-3.66	45.53
6	11400.00	58.44 PK	74.00	-15.56	1.35 H	54	7.70	50.74
7	11400.00	45.04 AV	54.00	-8.96	1.35 H	54	-5.70	50.74
ANTENNA POLARITY & TEST DISTANCE: VERTICAL AT 3 M								
NO.	FREQ. (MHz)	EMISSION LEVEL (dBuV/m)	LIMIT (dBuV/m)	MARGIN (dB)	ANTENNA HEIGHT (m)	TABLE ANGLE (Degree)	RAW VALUE (dBuV)	CORRECTION FACTOR (dB/m)
1	*5700.00	110.75 PK			1.00 V	220	70.68	40.07
2	*5700.00	100.22 AV			1.00 V	220	60.15	40.07
3	#5725.00	61.72 PK	68.30	-6.58	1.00 V	224	21.59	40.13
4	7600.00	55.18 PK	74.00	-18.82	1.00 V	16	9.65	45.53
5	7600.00	46.39 AV	54.00	-7.61	1.00 V	16	0.86	45.53
6	11400.00	58.91 PK	74.00	-15.09	1.05 V	256	8.17	50.74
7	11400.00	45.23 AV	54.00	-8.77	1.05 V	256	-5.51	50.74

- REMARKS:**
1. Emission level (dBuV/m) = Raw Value (dBuV) + Correction Factor (dB/m).
 2. Correction Factor (dB/m) = Antenna Factor (dB/m) + Cable Factor (dB).
 3. The other emission levels were very low against the limit.
 4. Margin value = Emission level – Limit value.
 5. “ * “: Fundamental frequency.
 6. “#”:The radiated frequency is out the restricted band.



A D T

DRAFT 802.11n (40MHz) OFDM MODULATION

EUT TEST CONDITION		MEASUREMENT DETAIL	
CHANNEL	Channel 54	FREQUENCY RANGE	1 ~ 40GHz
INPUT POWER (SYSTEM)	120Vac, 60 Hz	DETECTOR FUNCTION	Peak (PK) Average (AV)
ENVIRONMENTAL CONDITIONS	24deg. C, 70%RH 998hPa	TESTED BY	Lori Chiu

ANTENNA POLARITY & TEST DISTANCE: HORIZONTAL AT 3 M								
NO.	FREQ. (MHz)	EMISSION LEVEL (dBuV/m)	LIMIT (dBuV/m)	MARGIN (dB)	ANTENNA HEIGHT (m)	TABLE ANGLE (Degree)	RAW VALUE (dBuV)	CORRECTION FACTOR (dB/m)
1	5150.00	51.26 PK	74.00	-22.74	1.02 H	13	12.18	39.08
2	5150.00	39.40 AV	54.00	-14.60	1.02 H	13	0.32	39.08
3	*5270.00	95.30 PK			1.02 H	13	56.07	39.23
4	*5270.00	85.82 AV			1.02 H	13	46.59	39.23
5	#7027.00	51.41 PK	68.30	-16.89	1.00 H	108	7.02	44.39
6	#10540.00	58.04 PK	68.30	-10.26	1.00 H	3	8.05	49.99
ANTENNA POLARITY & TEST DISTANCE: VERTICAL AT 3 M								
NO.	FREQ. (MHz)	EMISSION LEVEL (dBuV/m)	LIMIT (dBuV/m)	MARGIN (dB)	ANTENNA HEIGHT (m)	TABLE ANGLE (Degree)	RAW VALUE (dBuV)	CORRECTION FACTOR (dB/m)
1	5150.00	51.37 PK	74.00	-22.63	1.45 V	49	12.29	39.08
2	5150.00	39.52 AV	54.00	-14.48	1.45 V	49	0.44	39.08
3	*5270.00	106.76 PK			1.45 V	49	67.53	39.23
4	*5270.00	95.69 AV			1.45 V	49	56.46	39.23
5	#7027.00	54.12 PK	68.30	-14.18	1.55 V	46	9.73	44.39
6	#10540.00	58.21 PK	68.30	-10.09	1.24 V	59	8.22	49.99

- REMARKS:**
1. Emission level (dBuV/m) = Raw Value (dBuV) + Correction Factor (dB/m).
 2. Correction Factor (dB/m) = Antenna Factor (dB/m) + Cable Factor (dB).
 3. The other emission levels were very low against the limit.
 4. Margin value = Emission level – Limit value.
 5. “ * “: Fundamental frequency.
 6. “#”: The radiated frequency is out the restricted band.



A D T

EUT TEST CONDITION		MEASUREMENT DETAIL	
CHANNEL	Channel 62	FREQUENCY RANGE	1 ~ 40GHz
INPUT POWER (SYSTEM)	120Vac, 60 Hz	DETECTOR FUNCTION	Peak (PK) Average (AV)
ENVIRONMENTAL CONDITIONS	24deg. C, 70%RH 998hPa	TESTED BY	Lori Chiu

ANTENNA POLARITY & TEST DISTANCE: HORIZONTAL AT 3 M								
NO.	FREQ. (MHz)	EMISSION LEVEL (dBuV/m)	LIMIT (dBuV/m)	MARGIN (dB)	ANTENNA HEIGHT (m)	TABLE ANGLE (Degree)	RAW VALUE (dBuV)	CORRECTION FACTOR (dB/m)
1	*5310.00	95.51 PK			1.30 H	50	56.24	39.27
2	*5310.00	86.35 AV			1.30 H	50	47.08	39.27
3	5350.00	49.72 PK	74.00	-24.28	1.28 H	50	10.41	39.31
4	5350.00	35.76 AV	54.00	-18.24	1.28 H	50	-3.55	39.31
5	#7080.00	53.69 PK	68.30	-14.61	1.02 H	25	9.00	44.70
6	10620.00	58.01 PK	74.00	-15.99	1.05 H	66	7.86	50.15
7	10620.00	43.89 AV	54.00	-10.11	1.05 H	66	-6.26	50.15
ANTENNA POLARITY & TEST DISTANCE: VERTICAL AT 3 M								
NO.	FREQ. (MHz)	EMISSION LEVEL (dBuV/m)	LIMIT (dBuV/m)	MARGIN (dB)	ANTENNA HEIGHT (m)	TABLE ANGLE (Degree)	RAW VALUE (dBuV)	CORRECTION FACTOR (dB/m)
1	*5310.00	107.17 PK			1.29 V	349	67.90	39.27
2	*5310.00	96.06 AV			1.29 V	349	56.79	39.27
3	5350.00	65.46 PK	74.00	-8.54	1.27 V	347	26.15	39.31
4	5350.00	48.26 AV	54.00	-5.74	1.27 V	347	8.95	39.31
5	#7080.00	53.60 PK	68.30	-14.70	1.72 V	105	8.91	44.70
6	10620.00	58.24 PK	74.00	-15.76	1.05 V	54	8.09	50.15
7	10620.00	44.50 AV	54.00	-9.50	1.05 V	54	-5.65	50.15

- REMARKS:**
1. Emission level (dBuV/m) = Raw Value (dBuV) + Correction Factor (dB/m).
 2. Correction Factor (dB/m) = Antenna Factor (dB/m) + Cable Factor (dB).
 3. The other emission levels were very low against the limit.
 4. Margin value = Emission level – Limit value.
 5. “ * “: Fundamental frequency.
 6. “#”:The radiated frequency is out the restricted band.



A D T

EUT TEST CONDITION		MEASUREMENT DETAIL	
CHANNEL	Channel 102	FREQUENCY RANGE	1 ~ 40GHz
INPUT POWER (SYSTEM)	120Vac, 60 Hz	DETECTOR FUNCTION	Peak (PK) Average (AV)
ENVIRONMENTAL CONDITIONS	24deg. C, 70%RH 998hPa	TESTED BY	Brad Wu

ANTENNA POLARITY & TEST DISTANCE: HORIZONTAL AT 3 M								
NO.	FREQ. (MHz)	EMISSION LEVEL (dBuV/m)	LIMIT (dBuV/m)	MARGIN (dB)	ANTENNA HEIGHT (m)	TABLE ANGLE (Degree)	RAW VALUE (dBuV)	CORRECTION FACTOR (dB/m)
1	5460.00	56.95 PK	74.00	-17.05	1.32 H	54	17.46	39.49
2	5460.00	38.98 AV	54.00	-15.02	1.32 H	54	-0.52	39.49
3	#5470.00	60.32 PK	68.30	-7.98	1.32 H	54	20.80	39.52
4	*5510.00	95.34 PK			1.32 H	54	55.73	39.61
5	*5510.00	85.86 AV			1.32 H	54	46.25	39.61
6	7347.00	54.67 PK	74.00	-19.33	1.01 H	319	9.08	45.59
7	7347.00	41.20 AV	54.00	-12.80	1.01 H	319	-4.39	45.59
8	11020.00	58.67 PK	74.00	-15.33	1.05 H	243	7.95	50.72
9	11020.00	44.94 AV	54.00	-9.06	1.05 H	243	-5.78	50.72
ANTENNA POLARITY & TEST DISTANCE: VERTICAL AT 3 M								
NO.	FREQ. (MHz)	EMISSION LEVEL (dBuV/m)	LIMIT (dBuV/m)	MARGIN (dB)	ANTENNA HEIGHT (m)	TABLE ANGLE (Degree)	RAW VALUE (dBuV)	CORRECTION FACTOR (dB/m)
1	5460.00	61.84 PK	74.00	-12.16	1.34 V	167	22.34	39.49
2	5460.00	40.81 AV	54.00	-13.19	1.34 V	167	1.31	39.49
3	#5470.00	67.14 PK	68.30	-1.16	1.34 V	167	27.62	39.52
4	*5510.00	106.94 PK			1.34 V	167	67.33	39.61
5	*5510.00	96.99 AV			1.34 V	167	57.38	39.61
6	7347.00	56.26 PK	74.00	-17.74	1.16 V	202	10.67	45.59
7	7347.00	46.97 AV	54.00	-7.03	1.16 V	202	1.38	45.59
8	11020.00	58.59 PK	74.00	-15.41	1.02 V	38	7.87	50.72
9	11020.00	44.81 AV	54.00	-9.19	1.02 V	38	-5.91	50.72

- REMARKS:**
1. Emission level (dBuV/m) = Raw Value (dBuV) + Correction Factor (dB/m).
 2. Correction Factor (dB/m) = Antenna Factor (dB/m) + Cable Factor (dB).
 3. The other emission levels were very low against the limit.
 4. Margin value = Emission level – Limit value.
 5. “ * “: Fundamental frequency.
 6. “#”:The radiated frequency is out the restricted band.



A D T

EUT TEST CONDITION		MEASUREMENT DETAIL	
CHANNEL	Channel 118	FREQUENCY RANGE	1 ~ 40GHz
INPUT POWER (SYSTEM)	120Vac, 60 Hz	DETECTOR FUNCTION	Peak (PK) Average (AV)
ENVIRONMENTAL CONDITIONS	24deg. C, 70%RH 998hPa	TESTED BY	Brad Wu

ANTENNA POLARITY & TEST DISTANCE: HORIZONTAL AT 3 M								
NO.	FREQ. (MHz)	EMISSION LEVEL (dBuV/m)	LIMIT (dBuV/m)	MARGIN (dB)	ANTENNA HEIGHT (m)	TABLE ANGLE (Degree)	RAW VALUE (dBuV)	CORRECTION FACTOR (dB/m)
1	*5590.00	95.66 PK			1.31 H	60	55.88	39.78
2	*5590.00	86.64 AV			1.31 H	60	46.86	39.78
3	7453.00	55.89 PK	74.00	-18.11	1.04 H	28	10.27	45.62
4	7453.00	42.38 AV	54.00	-11.62	1.04 H	28	-3.24	45.62
5	11180.00	58.49 PK	74.00	-15.51	1.03 H	25	7.85	50.64
6	11180.00	44.81 AV	54.00	-9.19	1.03 H	25	-5.83	50.64
ANTENNA POLARITY & TEST DISTANCE: VERTICAL AT 3 M								
NO.	FREQ. (MHz)	EMISSION LEVEL (dBuV/m)	LIMIT (dBuV/m)	MARGIN (dB)	ANTENNA HEIGHT (m)	TABLE ANGLE (Degree)	RAW VALUE (dBuV)	CORRECTION FACTOR (dB/m)
1	*5590.00	107.29 PK			1.45 V	182	67.51	39.78
2	*5590.00	96.54 AV			1.45 V	182	56.76	39.78
3	7453.00	58.69 PK	74.00	-15.31	1.00 V	214	13.08	45.62
4	7453.00	52.32 AV	54.00	-1.68	1.00 V	214	6.70	45.62
5	11180.00	58.05 PK	74.00	-15.95	1.06 V	259	7.41	50.64
6	11180.00	44.81 AV	54.00	-9.19	1.06 V	259	-5.83	50.64

- REMARKS:**
1. Emission level (dBuV/m) = Raw Value (dBuV) + Correction Factor (dB/m).
 2. Correction Factor (dB/m) = Antenna Factor (dB/m) + Cable Factor (dB).
 3. The other emission levels were very low against the limit.
 4. Margin value = Emission level – Limit value.
 5. “ * ”: Fundamental frequency.



A D T

EUT TEST CONDITION		MEASUREMENT DETAIL	
CHANNEL	Channel 134	FREQUENCY RANGE	1 ~ 40GHz
INPUT POWER (SYSTEM)	120Vac, 60 Hz	DETECTOR FUNCTION	Peak (PK) Average (AV)
ENVIRONMENTAL CONDITIONS	24deg. C, 70%RH 998hPa	TESTED BY	Brad Wu

ANTENNA POLARITY & TEST DISTANCE: HORIZONTAL AT 3 M								
NO.	FREQ. (MHz)	EMISSION LEVEL (dBuV/m)	LIMIT (dBuV/m)	MARGIN (dB)	ANTENNA HEIGHT (m)	TABLE ANGLE (Degree)	RAW VALUE (dBuV)	CORRECTION FACTOR (dB/m)
1	*5670.00	95.62 PK			1.34 H	61	55.63	39.99
2	*5670.00	86.35 AV			1.34 H	61	46.36	39.99
3	#5725.00	63.44 PK	68.30	-4.86	1.34 H	61	23.31	40.13
4	7560.00	56.89 PK	74.00	-17.11	1.13 H	29	11.33	45.56
5	7560.00	47.44 AV	54.00	-6.56	1.13 H	29	1.88	45.56
6	11340.00	59.13 PK	74.00	-14.87	1.13 H	95	8.44	50.69
7	11340.00	45.48 AV	54.00	-8.52	1.13 H	95	-5.21	50.69
ANTENNA POLARITY & TEST DISTANCE: VERTICAL AT 3 M								
NO.	FREQ. (MHz)	EMISSION LEVEL (dBuV/m)	LIMIT (dBuV/m)	MARGIN (dB)	ANTENNA HEIGHT (m)	TABLE ANGLE (Degree)	RAW VALUE (dBuV)	CORRECTION FACTOR (dB/m)
1	*5670.00	107.44 PK			1.24 V	183	67.45	39.99
2	*5670.00	96.59 AV			1.24 V	183	56.60	39.99
3	#5725.00	67.09 PK	68.30	-1.21	1.24 V	183	26.96	40.13
4	7560.00	57.74 PK	74.00	-16.26	1.00 V	246	12.18	45.56
5	7560.00	50.41 AV	54.00	-3.59	1.00 V	246	4.85	45.56
6	11340.00	57.25 PK	74.00	-16.75	1.21 V	29	6.56	50.69
7	11340.00	44.51 AV	54.00	-9.49	1.21 V	29	-6.18	50.69

- REMARKS:**
1. Emission level (dBuV/m) = Raw Value (dBuV) + Correction Factor (dB/m).
 2. Correction Factor (dB/m) = Antenna Factor (dB/m) + Cable Factor (dB).
 3. The other emission levels were very low against the limit.
 4. Margin value = Emission level – Limit value.
 5. “ * “: Fundamental frequency.
 6. “#”:The radiated frequency is out the restricted band.



A D T

BELOW 1GHz WORST-CASE DATA : 802.11a OFDM MODULATION

EUT TEST CONDITION		MEASUREMENT DETAIL	
CHANNEL	Channel 60	FREQUENCY RANGE	Below 1000MHz
INPUT POWER (SYSTEM)	120Vac, 60 Hz	DETECTOR FUNCTION	Quasi-Peak
ENVIRONMENTAL CONDITIONS	24deg. C, 70%RH 999hPa	TESTED BY	Lori Chiu

ANTENNA POLARITY & TEST DISTANCE: HORIZONTAL AT 3 M								
NO.	FREQ. (MHz)	EMISSION LEVEL (dBuV/m)	LIMIT (dBuV/m)	MARGIN (dB)	ANTENNA HEIGHT (m)	TABLE ANGLE (Degree)	RAW VALUE (dBuV)	CORRECTION FACTOR (dB/m)
1	103.78	32.35 QP	43.50	-11.15	1.50 H	229	22.58	9.77
2	199.05	32.02 QP	43.50	-11.48	1.00 H	112	21.39	10.63
3	500.42	37.82 QP	46.00	-8.18	1.00 H	184	18.71	19.12
4	566.52	38.86 QP	46.00	-7.14	1.50 H	214	18.15	20.71
5	599.58	36.72 QP	46.00	-9.28	1.50 H	184	15.22	21.50
6	700.68	35.70 QP	46.00	-10.30	1.00 H	181	13.20	22.50
7	799.84	36.22 QP	46.00	-9.78	1.00 H	268	11.30	24.92
ANTENNA POLARITY & TEST DISTANCE: VERTICAL AT 3 M								
NO.	FREQ. (MHz)	EMISSION LEVEL (dBuV/m)	LIMIT (dBuV/m)	MARGIN (dB)	ANTENNA HEIGHT (m)	TABLE ANGLE (Degree)	RAW VALUE (dBuV)	CORRECTION FACTOR (dB/m)
1	57.12	28.09 QP	40.00	-11.91	1.00 V	208	14.62	13.47
2	96.01	35.64 QP	43.50	-7.86	1.00 V	256	26.38	9.26
3	150.45	31.14 QP	43.50	-12.36	1.00 V	262	17.29	13.85
4	249.60	33.59 QP	46.00	-12.41	1.00 V	79	20.83	12.76
5	374.04	33.54 QP	46.00	-12.46	1.00 V	109	18.16	15.37
6	500.42	33.76 QP	46.00	-12.24	1.00 V	175	14.64	19.12
7	566.52	37.54 QP	46.00	-8.46	1.00 V	103	16.82	20.71
8	799.84	35.92 QP	46.00	-10.08	1.50 V	325	10.99	24.92

- REMARKS:**
1. Emission level (dBuV/m) = Raw Value (dBuV) + Correction Factor (dB/m).
 2. Correction Factor (dB/m) = Antenna Factor (dB/m) + Cable Factor (dB).
 3. The other emission levels were very low against the limit.
 4. Margin value = Emission level – Limit value.



A D T

BELOW 1GHz WORST-CASE DATA : 802.11a OFDM MODULATION

EUT TEST CONDITION		MEASUREMENT DETAIL	
CHANNEL	Channel 100	FREQUENCY RANGE	Below 1000MHz
INPUT POWER (SYSTEM)	120Vac, 60 Hz	DETECTOR FUNCTION	Quasi-Peak
ENVIRONMENTAL CONDITIONS	24deg. C, 70%RH 999hPa	TESTED BY	Lori Chiu

ANTENNA POLARITY & TEST DISTANCE: HORIZONTAL AT 3 M								
NO.	FREQ. (MHz)	EMISSION LEVEL (dBuV/m)	LIMIT (dBuV/m)	MARGIN (dB)	ANTENNA HEIGHT (m)	TABLE ANGLE (Degree)	RAW VALUE (dBuV)	CORRECTION FACTOR (dB/m)
1	103.82	33.10 QP	43.50	-10.40	1.00 H	214	23.32	9.78
2	500.54	37.65 QP	46.00	-8.35	1.00 H	134	18.53	19.12
3	566.64	39.15 QP	46.00	-6.85	1.50 H	146	18.43	20.72
4	599.54	35.88 QP	46.00	-10.12	1.50 H	341	14.38	21.50
5	700.74	35.97 QP	46.00	-10.03	1.00 H	10	13.47	22.50
6	799.72	37.45 QP	46.00	-8.55	1.00 H	168	12.53	24.92
ANTENNA POLARITY & TEST DISTANCE: VERTICAL AT 3 M								
NO.	FREQ. (MHz)	EMISSION LEVEL (dBuV/m)	LIMIT (dBuV/m)	MARGIN (dB)	ANTENNA HEIGHT (m)	TABLE ANGLE (Degree)	RAW VALUE (dBuV)	CORRECTION FACTOR (dB/m)
1	57.28	28.15 QP	40.00	-11.85	1.00 V	35	14.69	13.46
2	96.20	35.01 QP	43.50	-8.49	1.25 V	316	25.75	9.26
3	150.35	32.52 QP	43.50	-10.98	1.00 V	182	18.67	13.85
4	500.57	34.29 QP	46.00	-11.71	1.00 V	198	15.17	19.12
5	566.46	36.86 QP	46.00	-9.14	1.75 V	288	16.15	20.71
6	799.92	35.89 QP	46.00	-10.11	1.50 V	261	10.96	24.93

- REMARKS:**
1. Emission level (dBuV/m) = Raw Value (dBuV) + Correction Factor (dB/m).
 2. Correction Factor (dB/m) = Antenna Factor (dB/m) + Cable Factor (dB).
 3. The other emission levels were very low against the limit.
 4. Margin value = Emission level – Limit value.

4.2 CONDUCTED EMISSION MEASUREMENT

4.2.1 LIMITS OF CONDUCTED EMISSION MEASUREMENT

FREQUENCY OF EMISSION (MHz)	CONDUCTED LIMIT (dB μ V)	
	Quasi-peak	Average
0.15 ~ 0.5	66 to 56	56 to 46
0.5 ~ 5	56	46
5 ~ 30	60	50

- NOTE:**
1. The lower limit shall apply at the transition frequencies.
 2. The limit decreases in line with the logarithm of the frequency in the range of 0.15 to 0.50MHz.
 3. All emanations from a class A/B digital device or system, including any network of conductors and apparatus connected thereto, shall not exceed the level of field strengths specified above.

4.2.2 TEST INSTRUMENTS

DESCRIPTION & MANUFACTURER	MODEL NO.	SERIAL NO.	DATE OF CALIBRATION	DUE DATE OF CALIBRATION
Test Receiver ROHDE & SCHWARZ	ESCS30	100288	Sep. 22, 2007	Sep. 21, 2008
RF signal cable Woken	5D-FB	Cable-HYCO3-01	Jan. 07, 2008	Jan. 06, 2009
LISN ROHDE & SCHWARZ	ESH2-Z5	100100	Jan. 10, 2008	Jan. 09, 2009
LISN SCHWARZBECK	NNBL 8226-2	8226-142	May 08, 2007	May 07, 2008
Software ADT	ADT_Cond_V3	NA	NA	NA

- NOTE:**
1. The calibration interval of the above test instruments is 12 months and the calibrations are traceable to NML/ROC and NIST/USA.
 2. The test was performed in HwaYa Shielded Room 2.
 3. The VCCI Site Registration No. is C-2047.

4.2.3 TEST PROCEDURES

- a. The EUT was placed 0.4 meters from the conducting wall of the shielded room with EUT being connected to the power mains through a line impedance stabilization network (LISN). Other support units were connected to the power mains through another LISN. The two LISNs provide 50 ohm/ 50uH of coupling impedance for the measuring instrument.
- b. Both lines of the power mains connected to the EUT were checked for maximum conducted interference.
- c. The frequency range from 150kHz to 30MHz was searched. Emission levels under (Limit - 20dB) was not recorded.

4.2.4 DEVIATION FROM TEST STANDARD

No deviation

4.2.5 TEST SETUP

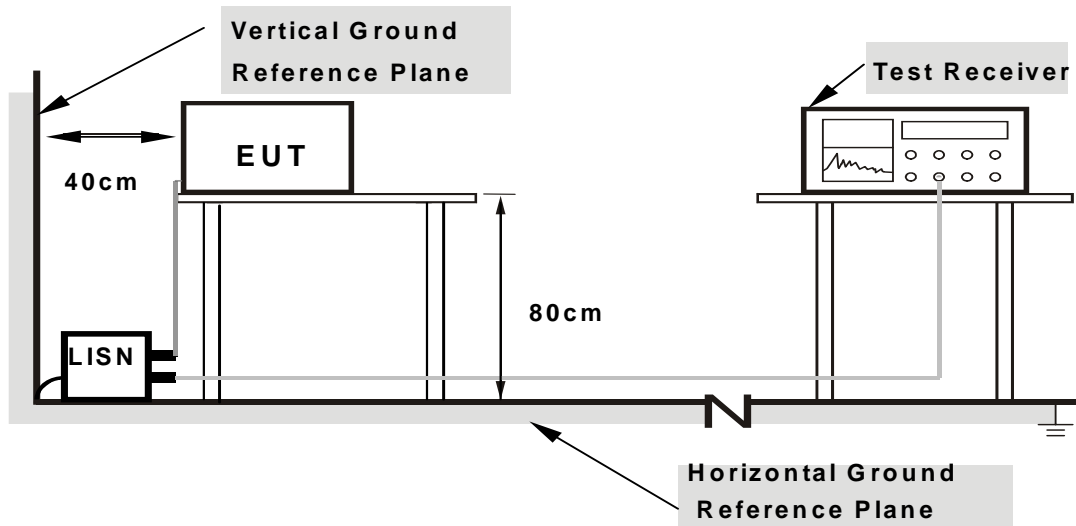

Note: 1.Support units were connected to second LISN.

2.Both of LISNs (AMN) are 80 cm from EUT and at least 80 from other units and other metal planes

For the actual test configuration, please refer to the attached file (Test Setup Photo).

4.2.6 EUT OPERATING CONDITIONS

Same as 4.1.6.

4.2.7 TEST RESULTS

**CONDUCTED WORST-CASE DATA :
FOR 5250-5350MHz BAND: 802.11a OFDM MODULATION**

EUT TEST CONDITION		MEASUREMENT DETAIL	
CHANNEL	Channel 60	PHASE	Line 1
MODULATION TYPE	BPSK	INPUT POWER (SYSTEM)	120Vac, 60Hz
TRANSFER RATE	6.0Mbps	6dB BANDWIDTH	9kHz
ENVIRONMENTAL CONDITIONS	21deg. C, 66%RH, 982hPa	TESTED BY	Dean Wang

No	Freq. [MHz]	Corr. Factor (dB)	Reading Value		Emission Level		Limit		Margin	
			[dB (uV)]		[dB (uV)]		[dB (uV)]		(dB)	
			Q.P.	AV.	Q.P.	AV.	Q.P.	AV.	Q.P.	AV.
1	0.163	0.10	51.70	-	51.80	-	65.31	55.31	-13.51	-
2	0.216	0.10	44.52	-	44.62	-	62.95	52.95	-18.33	-
3	0.271	0.10	39.17	-	39.27	-	61.08	51.08	-21.81	-
4	0.597	0.10	39.05	-	39.15	-	56.00	46.00	-16.85	-
5	2.332	0.23	33.52	-	33.75	-	56.00	46.00	-22.25	-
6	29.125	1.17	28.48	-	29.65	-	60.00	50.00	-30.35	-

- REMARKS:**
1. Q.P. and AV. are abbreviations of quasi-peak and average individually.
 2. "-": The Quasi-peak reading value also meets average limit and measurement with the average detector is unnecessary.
 3. The emission levels of other frequencies were very low against the limit.
 4. Margin value = Emission level - Limit value
 5. Correction factor = Insertion loss + Cable loss
 6. Emission Level = Correction Factor + Reading Value.

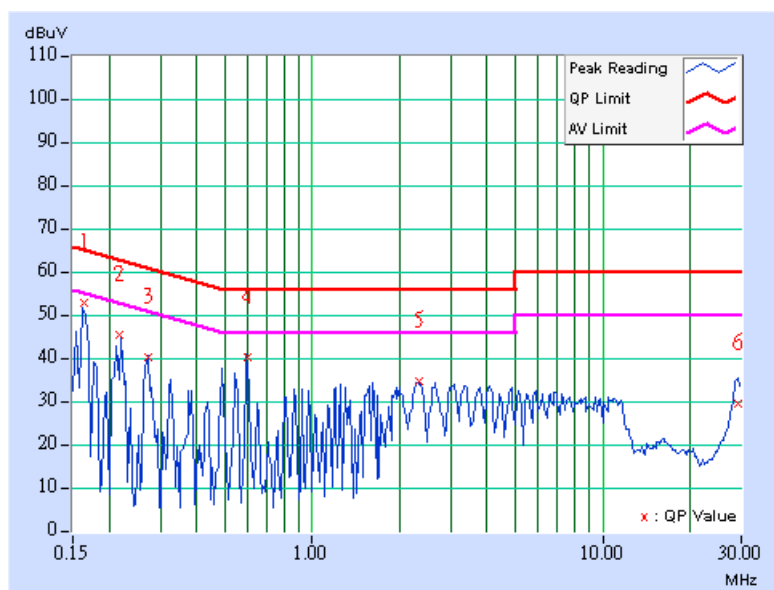



A D T

EUT TEST CONDITION		MEASUREMENT DETAIL	
CHANNEL	Channel 60	PHASE	Line 2
MODULATION TYPE	BPSK	INPUT POWER (SYSTEM)	120Vac, 60Hz
TRANSFER RATE	6.0Mbps	6dB BANDWIDTH	9kHz
ENVIRONMENTAL CONDITIONS	21deg. C, 66%RH, 982hPa	TESTED BY	Dean Wang

No	Freq. [MHz]	Corr. Factor (dB)	Reading Value [dB (uV)]		Emission Level [dB (uV)]		Limit [dB (uV)]		Margin (dB)	
			Q.P.	AV.	Q.P.	AV.	Q.P.	AV.	Q.P.	AV.
			1	0.163	0.10	51.32	-	51.42	-	65.31
2	0.218	0.10	44.66	-	44.76	-	62.91	52.91	-18.15	-
3	0.488	0.12	38.40	-	38.52	-	56.19	46.19	-17.68	-
4	0.596	0.14	40.41	-	40.55	-	56.00	46.00	-15.45	-
5	2.328	0.23	32.83	-	33.06	-	56.00	46.00	-22.94	-
6	11.285	0.44	31.08	-	31.52	-	60.00	50.00	-28.48	-

- REMARKS:**
1. Q.P. and AV. are abbreviations of quasi-peak and average individually.
 2. "-": The Quasi-peak reading value also meets average limit and measurement with the average detector is unnecessary.
 3. The emission levels of other frequencies were very low against the limit.
 4. Margin value = Emission level - Limit value
 5. Correction factor = Insertion loss + Cable loss
 6. Emission Level = Correction Factor + Reading Value.

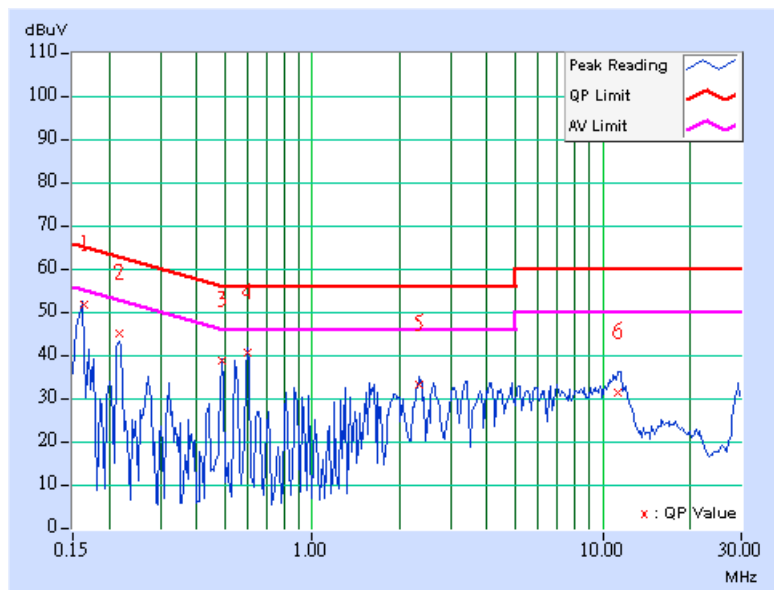



FOR 5470-5725MHz BAND: 802.11a OFDM MODULATION

EUT TEST CONDITION		MEASUREMENT DETAIL	
CHANNEL	Channel 100	PHASE	Line 1
MODULATION TYPE	BPSK	INPUT POWER (SYSTEM)	120Vac, 60Hz
TRANSFER RATE	6.0Mbps	6dB BANDWIDTH	9kHz
ENVIRONMENTAL CONDITIONS	23deg. C, 70%RH, 982hPa	TESTED BY	Dean Wang

No	Freq. [MHz]	Corr. Factor (dB)	Reading Value		Emission Level		Limit		Margin	
			[dB (uV)]		[dB (uV)]		[dB (uV)]		(dB)	
			Q.P.	AV.	Q.P.	AV.	Q.P.	AV.	Q.P.	AV.
1	0.163	0.10	52.27	-	52.37	-	65.30	55.30	-12.93	-
2	0.218	0.10	44.87	-	44.97	-	62.90	52.90	-17.93	-
3	0.490	0.10	36.84	-	36.94	-	56.16	46.16	-19.22	-
4	0.599	0.10	38.32	-	38.42	-	56.00	46.00	-17.58	-
5	2.282	0.23	32.75	-	32.98	-	56.00	46.00	-23.02	-
6	29.031	1.16	28.27	-	29.43	-	60.00	50.00	-30.57	-

- REMARKS:**
1. Q.P. and AV. are abbreviations of quasi-peak and average individually.
 2. "-": The Quasi-peak reading value also meets average limit and measurement with the average detector is unnecessary.
 3. The emission levels of other frequencies were very low against the limit.
 4. Margin value = Emission level - Limit value
 5. Correction factor = Insertion loss + Cable loss
 6. Emission Level = Correction Factor + Reading Value.

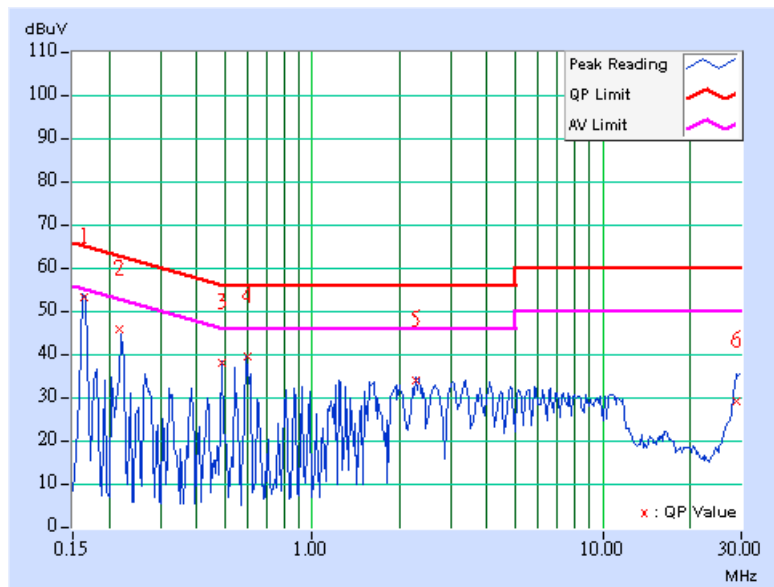



A D T

EUT TEST CONDITION		MEASUREMENT DETAIL	
CHANNEL	Channel 100	PHASE	Line 2
MODULATION TYPE	BPSK	INPUT POWER (SYSTEM)	120Vac, 60Hz
TRANSFER RATE	6.0Mbps	6dB BANDWIDTH	9kHz
ENVIRONMENTAL CONDITIONS	23deg. C, 70%RH, 982hPa	TESTED BY	Dean Wang

No	Freq. [MHz]	Corr. Factor (dB)	Reading Value [dB (uV)]		Emission Level [dB (uV)]		Limit [dB (uV)]		Margin (dB)	
			Q.P.	AV.	Q.P.	AV.	Q.P.	AV.	Q.P.	AV.
			1	0.163	0.10	51.73	-	51.83	-	65.30
2	0.218	0.10	44.80	-	44.90	-	62.90	52.90	-18.00	-
3	0.490	0.12	38.23	-	38.35	-	56.17	46.17	-17.82	-
4	0.597	0.14	40.18	-	40.32	-	56.00	46.00	-15.68	-
5	1.626	0.22	31.97	-	32.19	-	56.00	46.00	-23.81	-
6	11.301	0.44	30.73	-	31.17	-	60.00	50.00	-28.83	-

- REMARKS:**
1. Q.P. and AV. are abbreviations of quasi-peak and average individually.
 2. "-": The Quasi-peak reading value also meets average limit and measurement with the average detector is unnecessary.
 3. The emission levels of other frequencies were very low against the limit.
 4. Margin value = Emission level - Limit value
 5. Correction factor = Insertion loss + Cable loss
 6. Emission Level = Correction Factor + Reading Value.

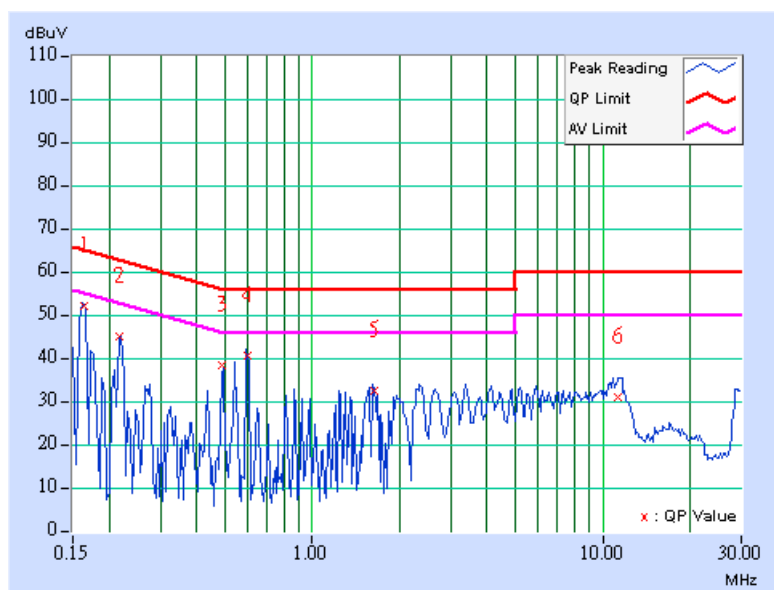

4.3 PEAK TRANSMIT POWER MEASUREMENT

4.3.1 LIMITS OF PEAK TRANSMIT POWER MEASUREMENT

FREQUENCY BAND	LIMIT
5.250 ~ 5.350GHz	The lesser of 250mW (24dBm) or 11dBm + 10logB
5.470 ~ 5.725GHz	The lesser of 250mW (24dBm) or 11dBm + 10logB

NOTE: Where B is the 26dB emission bandwidth in MHz.

4.3.2 TEST INSTRUMENTS

DESCRIPTION & MANUFACTURER	MODEL NO.	SERIAL NO.	DATE OF CALIBRATION	DUE DATE OF CALIBRATION
R&S SPECTRUM ANALYZER	FSP40	100040	Jun. 29, 2007	Jun. 28, 2008

NOTE: The calibration interval of the above test instruments is 12 months and the calibrations are traceable to NML/ROC and NIST/USA.

4.3.3 TEST PROCEDURE

- a. The transmitter output was connected to the spectrum analyzer.
- b. Set span to encompass the entire emission bandwidth of the signal.
- c. Set RBW to 1MHz, VBW to 3MHz.
- d. Using the spectrum analyzer's channel power measurement function to measure the output power.

NOTE: The test is performed in accordance with FCC Public Notice: APPENDIX A Guidelines for Assessing Unlicensed National Information Infrastructure (U-NII) Devices – Part 15, Subpart E, August 2002.

The transmitter output operates continuously therefore Method # 1 is used.

4.3.4 DEVIATION FROM TEST STANDARD

No deviation

4.3.5 TEST SETUP



4.3.6 EUT OPERATING CONDITIONS

The software provided by client to enable the EUT under transmission condition continuously at specific channel frequencies individually.

4.3.7 TEST RESULTS

PEAK POWER OUTPUT: 802.11a OFDM MODULATION

MODULATION TYPE	BPSK	TRANSFER RATE	6.0Mbps
INPUT POWER (SYSTEM)	120Vac, 60Hz	ENVIRONMENTAL CONDITIONS	25 deg.C, 65 %RH, 991hPa
TESTED BY	Brad Wu		

CHANNEL	CHANNEL FREQUENCY (MHz)	PEAK POWER OUTPUT (mW)	PEAK POWER OUTPUT (dBm)	PEAK POWER LIMIT (dBm)	PASS / FAIL
52	5260	28.249	14.51	24.00	PASS
60	5300	28.973	14.62	24.00	PASS
64	5320	28.642	14.57	24.00	PASS
100	5500	28.973	14.62	24.00	PASS
120	5600	28.907	14.61	24.00	PASS
140	5700	28.840	14.60	24.00	PASS



A D T

CH 52

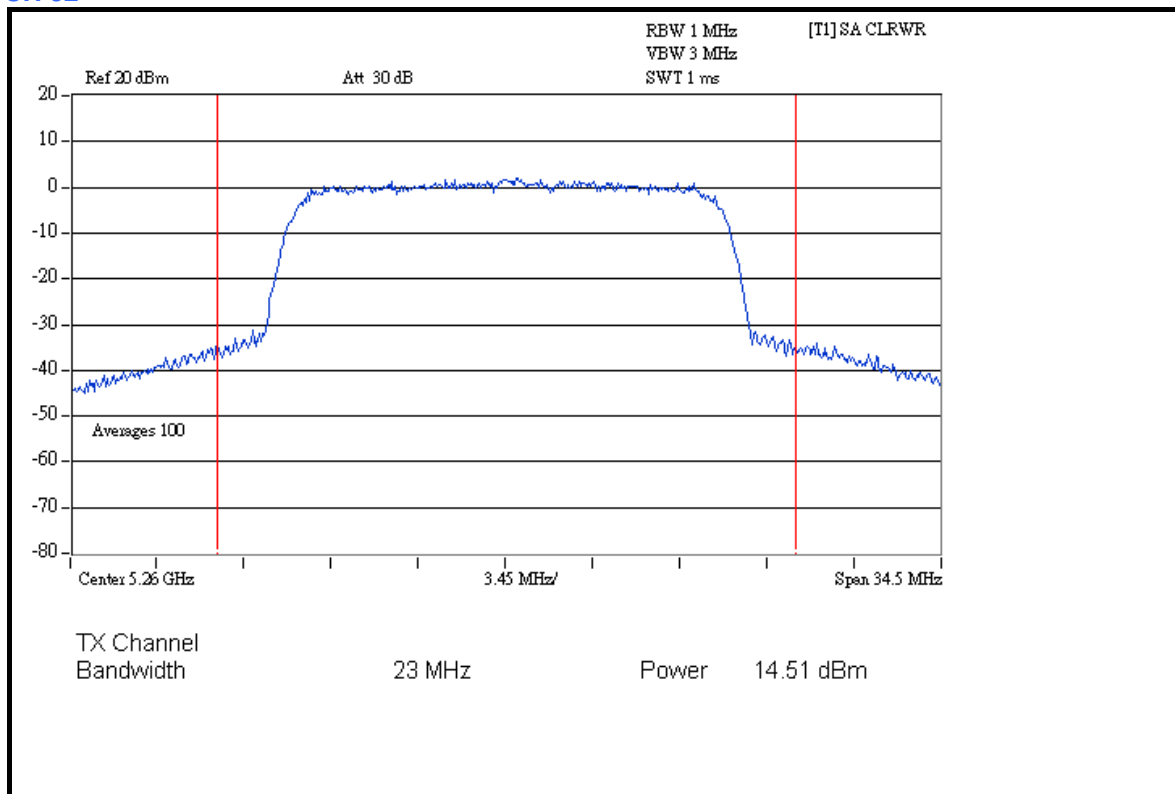

CH 60

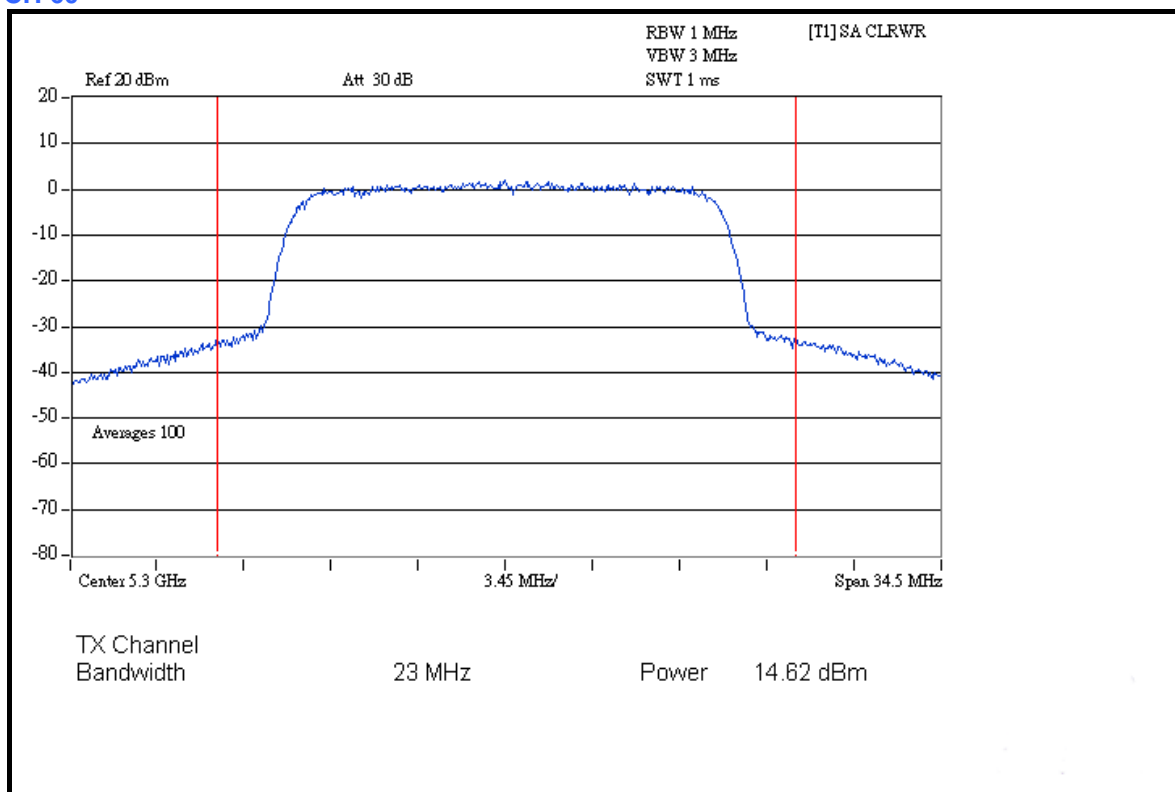



A D T

CH 64

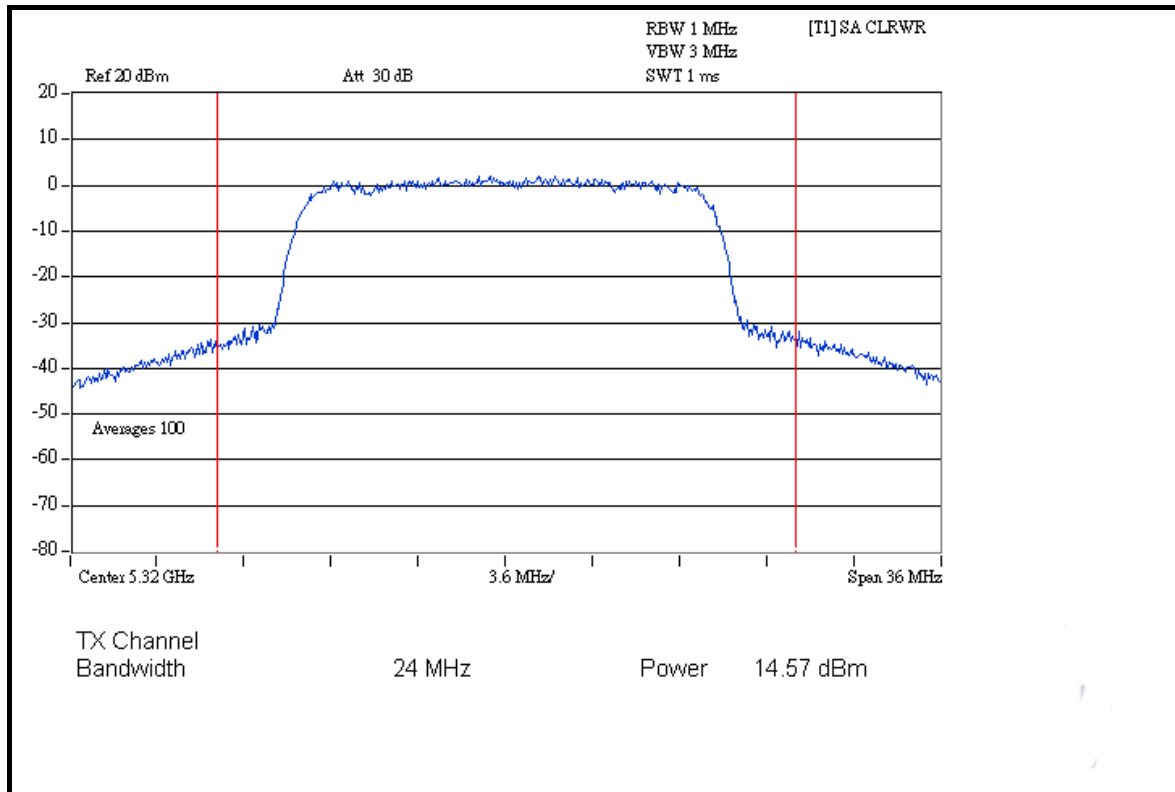

CH 100

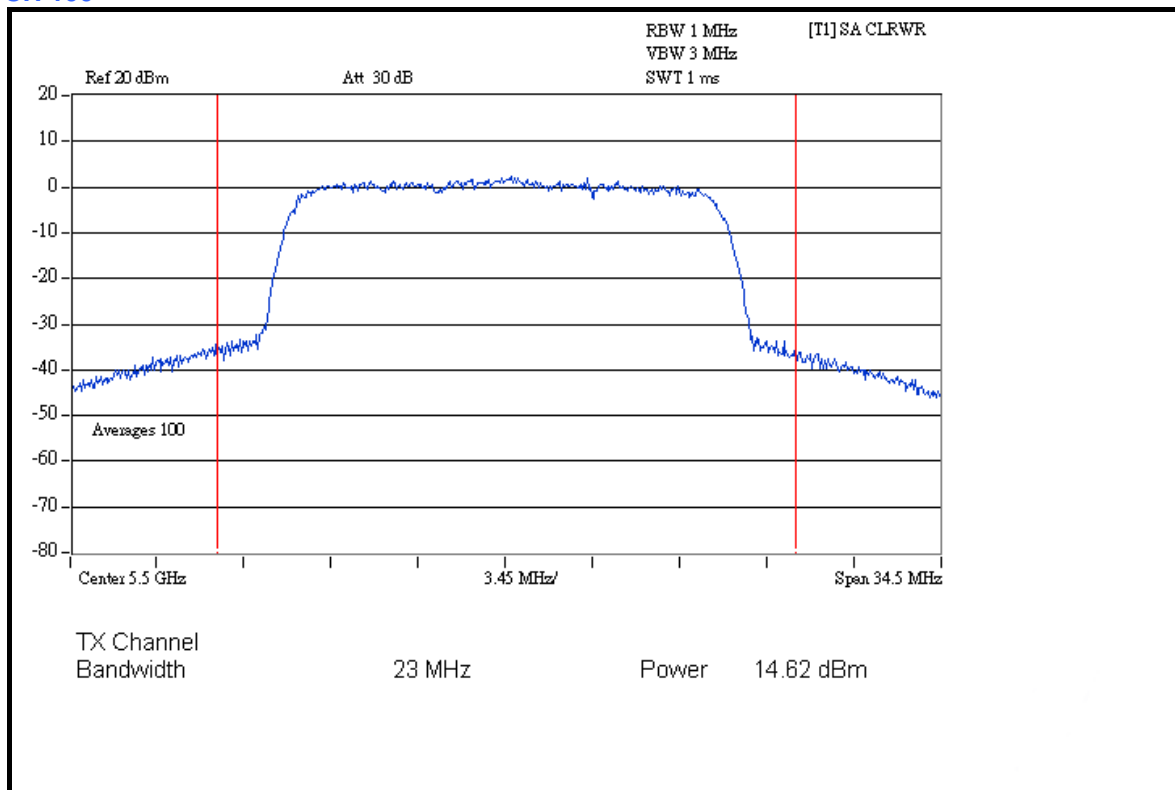



A D T

CH 120

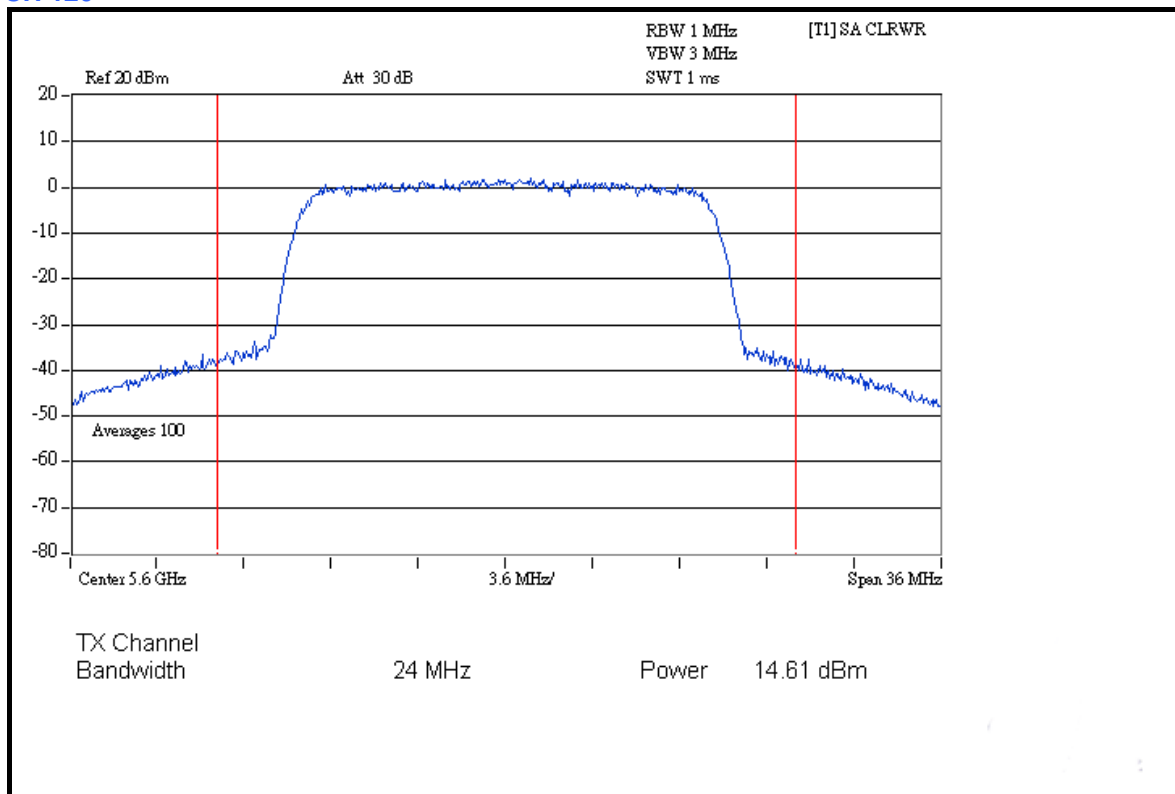

CH 140

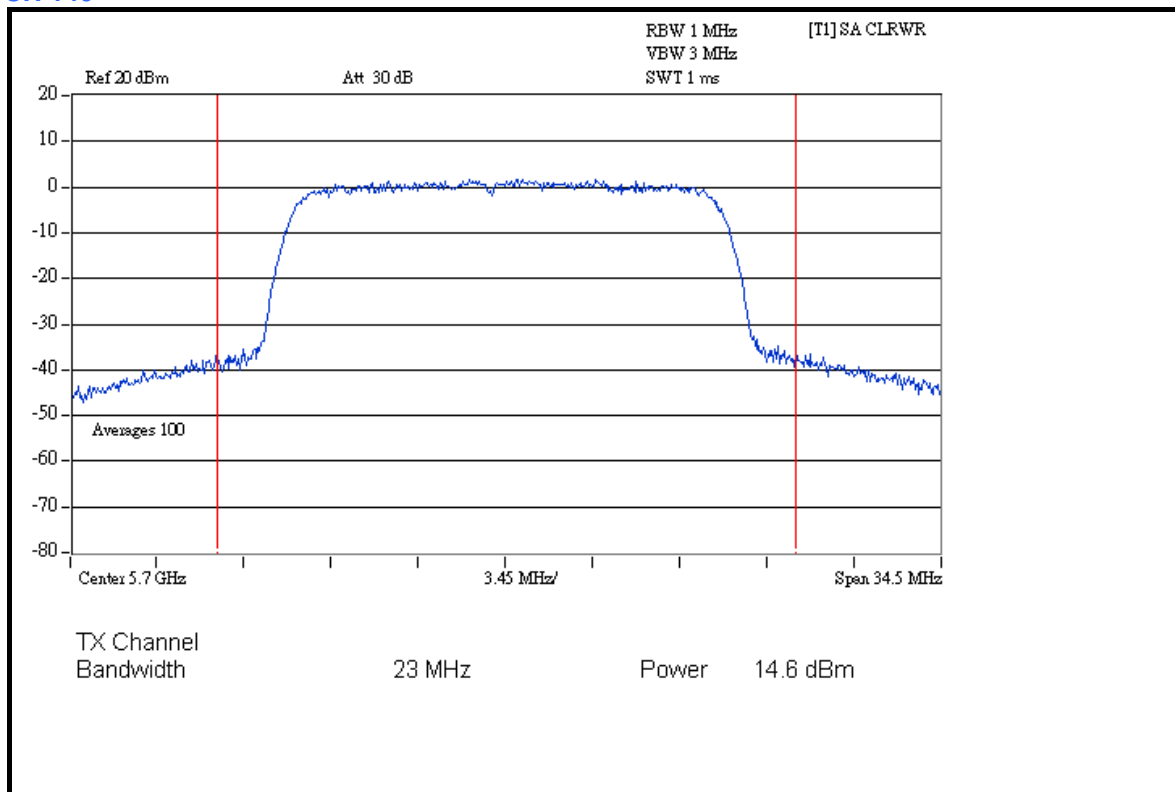



A D T

DRAFT 802.11n (20MHz) OFDM MODULATION

MODULATION TYPE	BPSK	TRANSFER RATE	7.2Mbps
INPUT POWER (SYSTEM)	120Vac, 60Hz	ENVIRONMENTAL CONDITIONS	25 deg.C, 65 %RH, 991hPa
TESTED BY	Brad Wu		

CHAN.	CHAN. FREQ. (MHz)	PEAK POWER OUTPUT (dBm)		TOTAL PEAK POWER (mW)	TOTAL PEAK POWER (dBm)	PEAK POWER LIMIT (dBm)	PASS / FAIL
		CHAIN 0	CHAIN 1				
52	5260	11.55	11.63	28.844	14.60	24	PASS
60	5300	11.59	11.61	28.909	14.61	24	PASS
64	5320	11.62	11.58	28.909	14.61	24	PASS
100	5500	11.53	11.58	28.611	14.57	24	PASS
120	5600	11.58	11.57	28.743	14.59	24	PASS
140	5700	11.59	11.51	28.579	14.56	24	PASS



A D T

CHAIN 0: CH 52

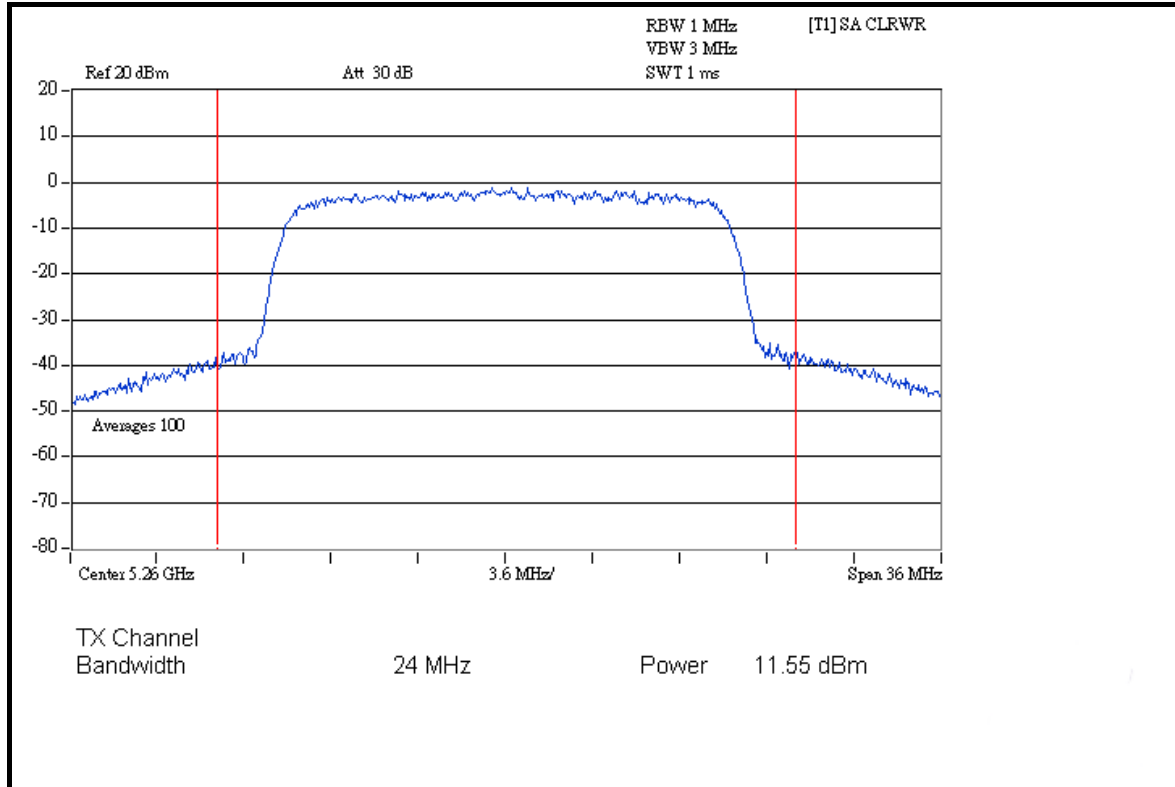

CH 60

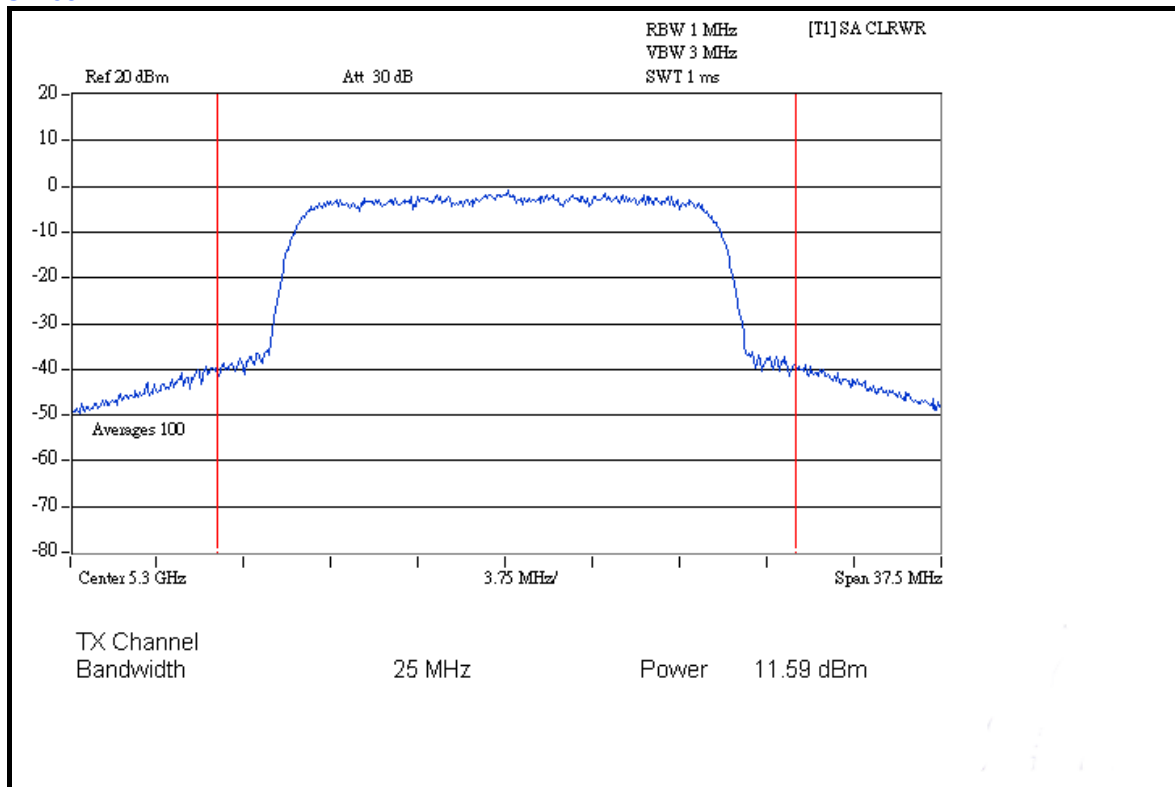



A D T

CH 64

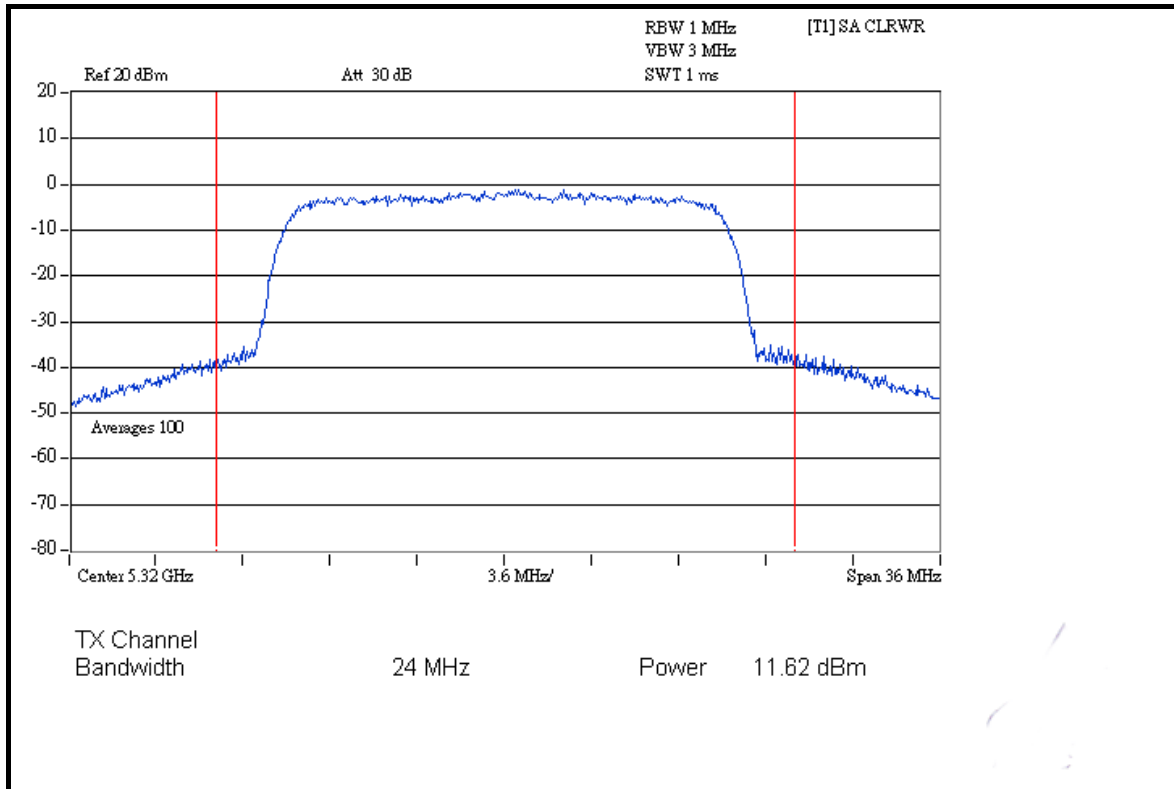

CH 100

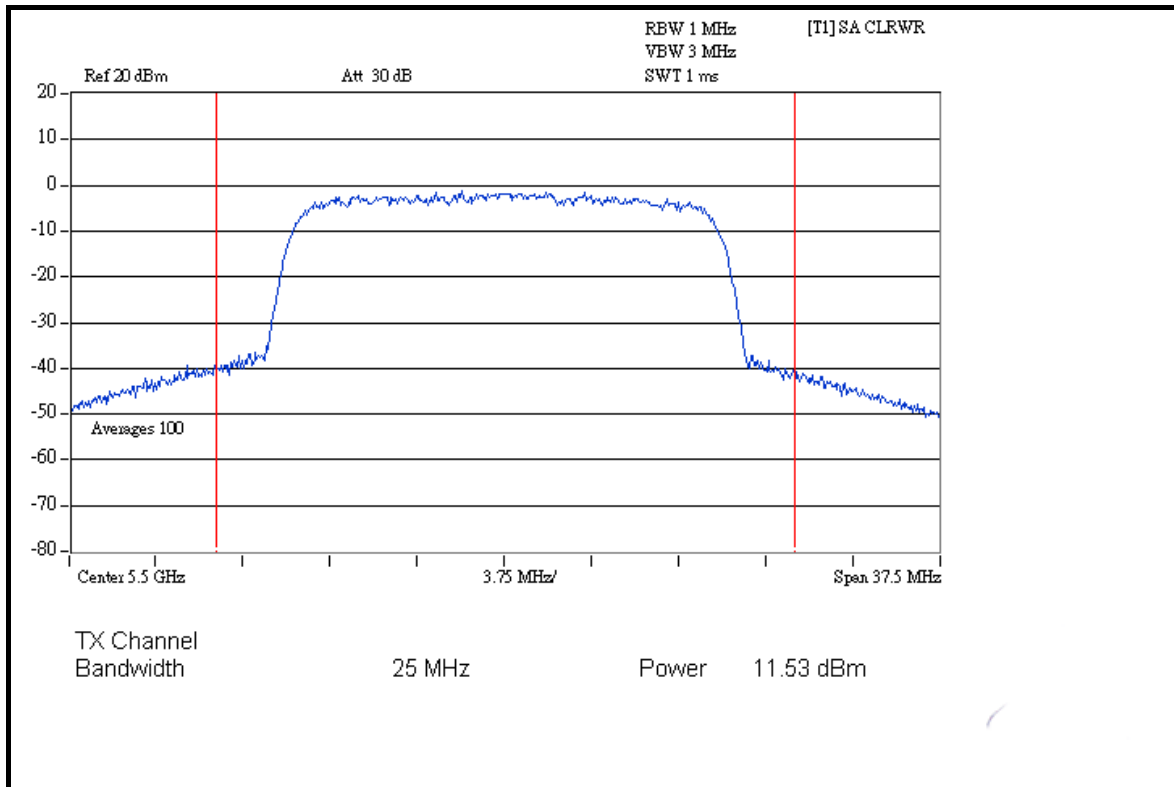



A D T

CH 120

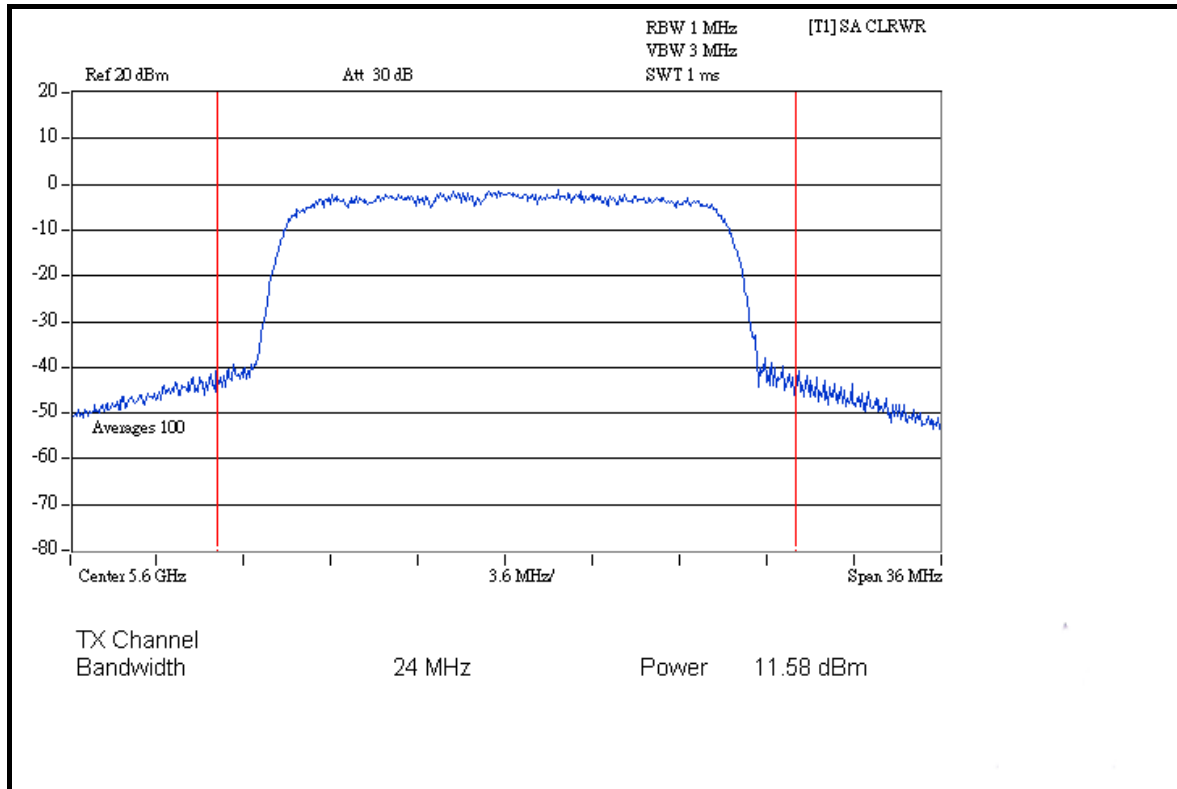

CH 140

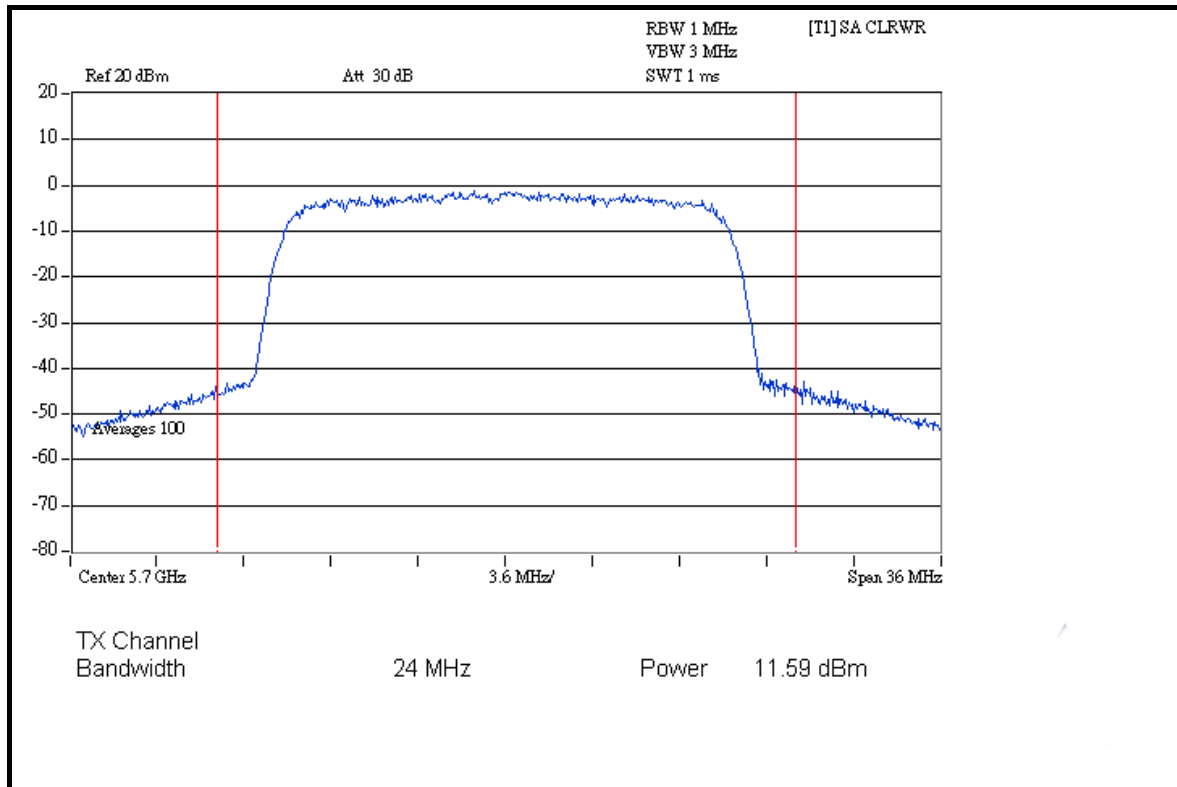



A D T

CHAIN 1: CH 52

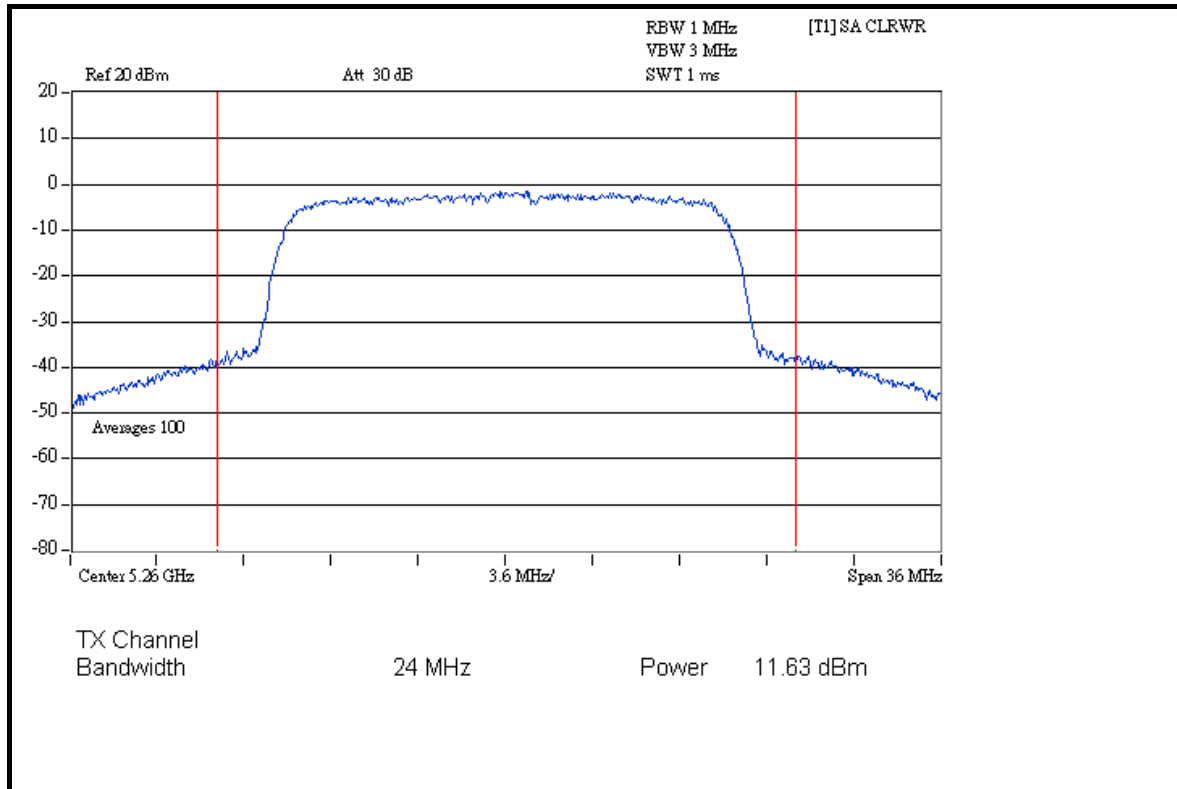

CH 60

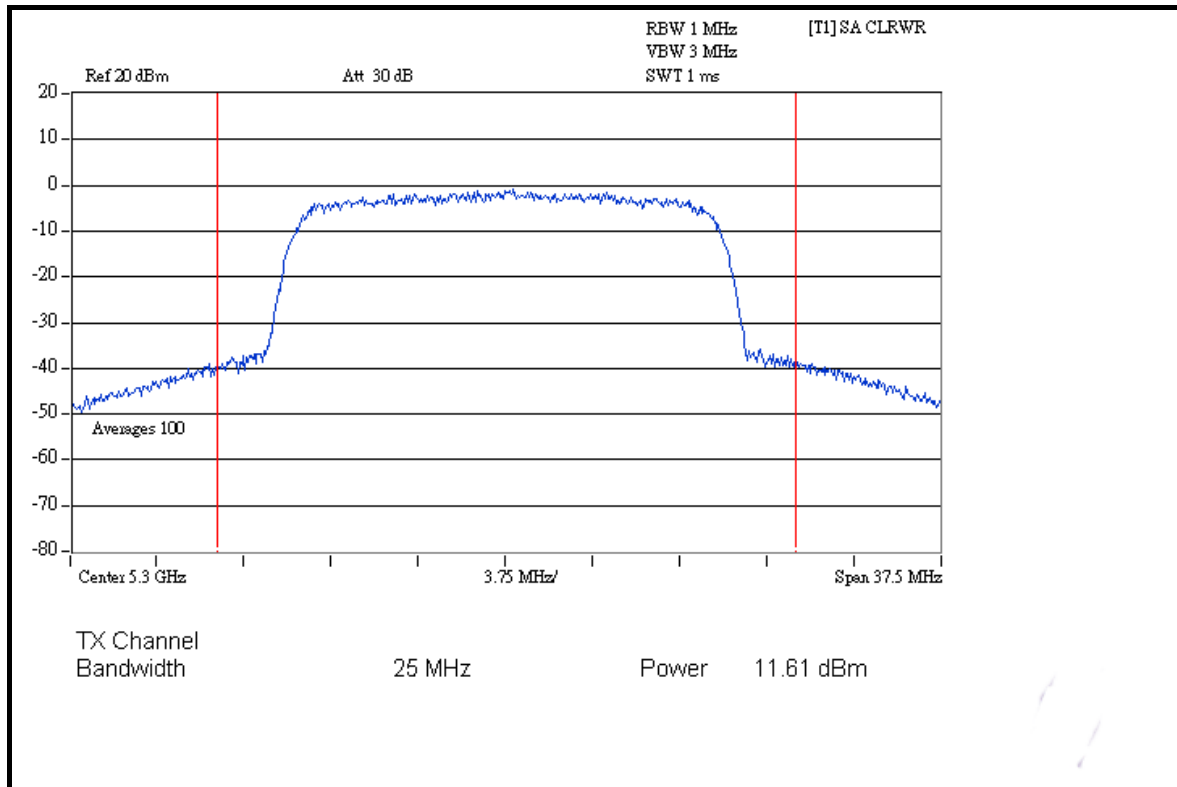



A D T

CH 64

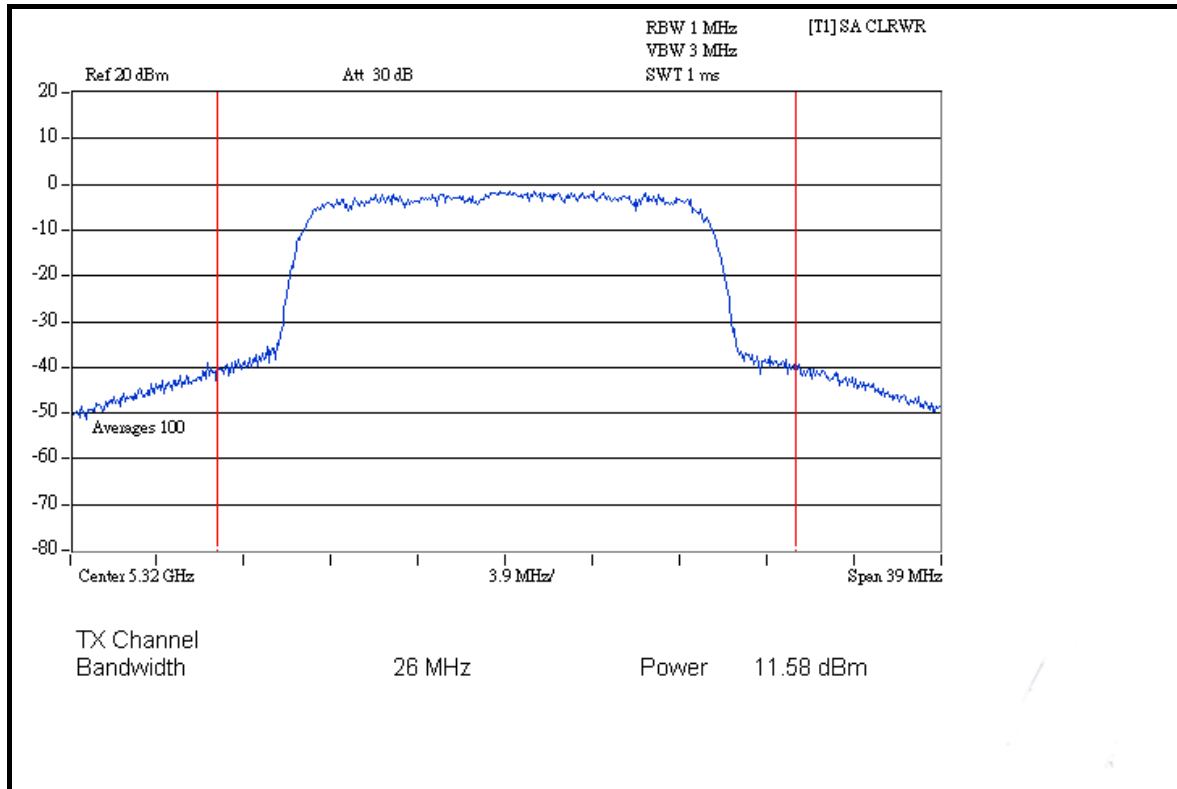

CH 100

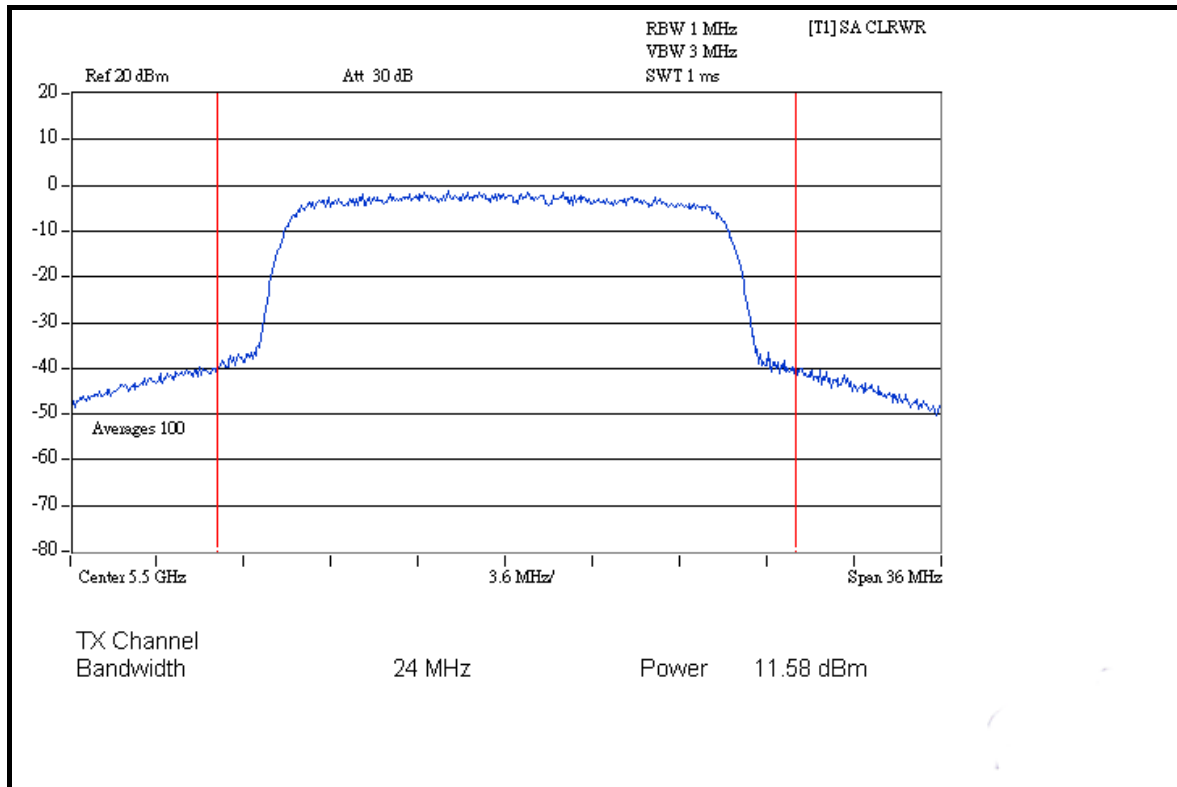



A D T

CH 120

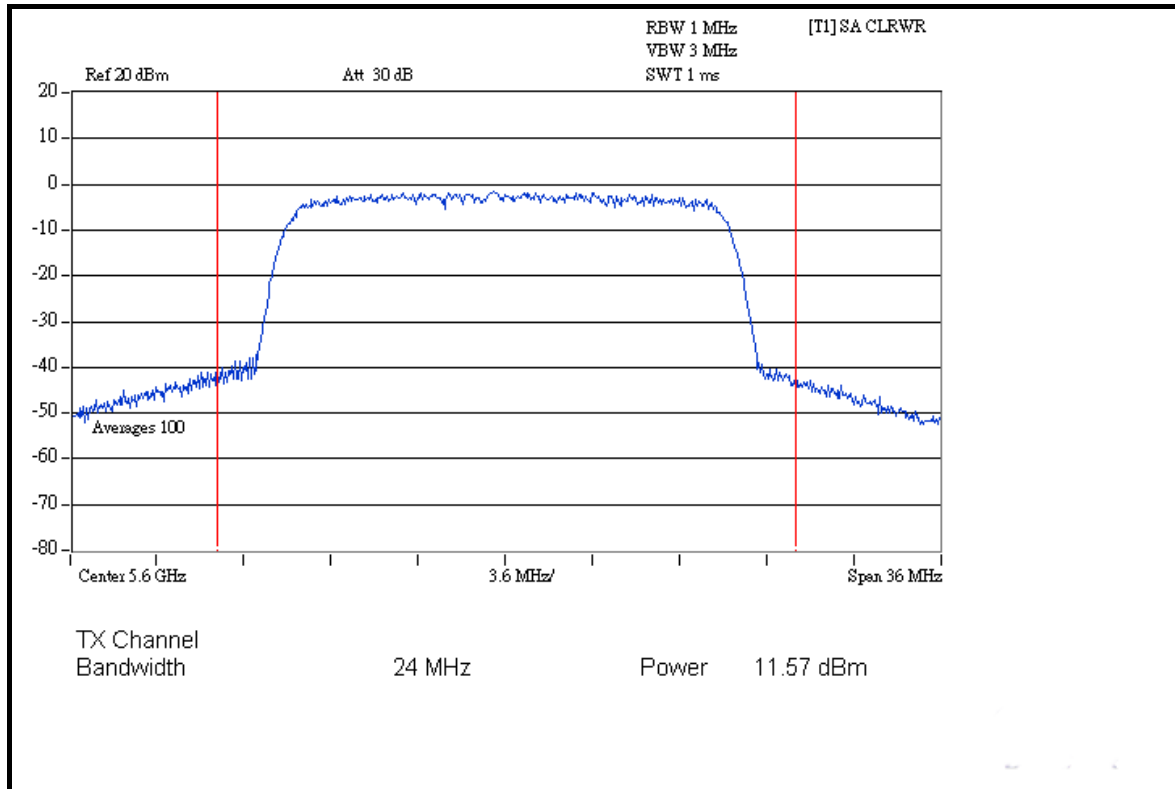

CH 140

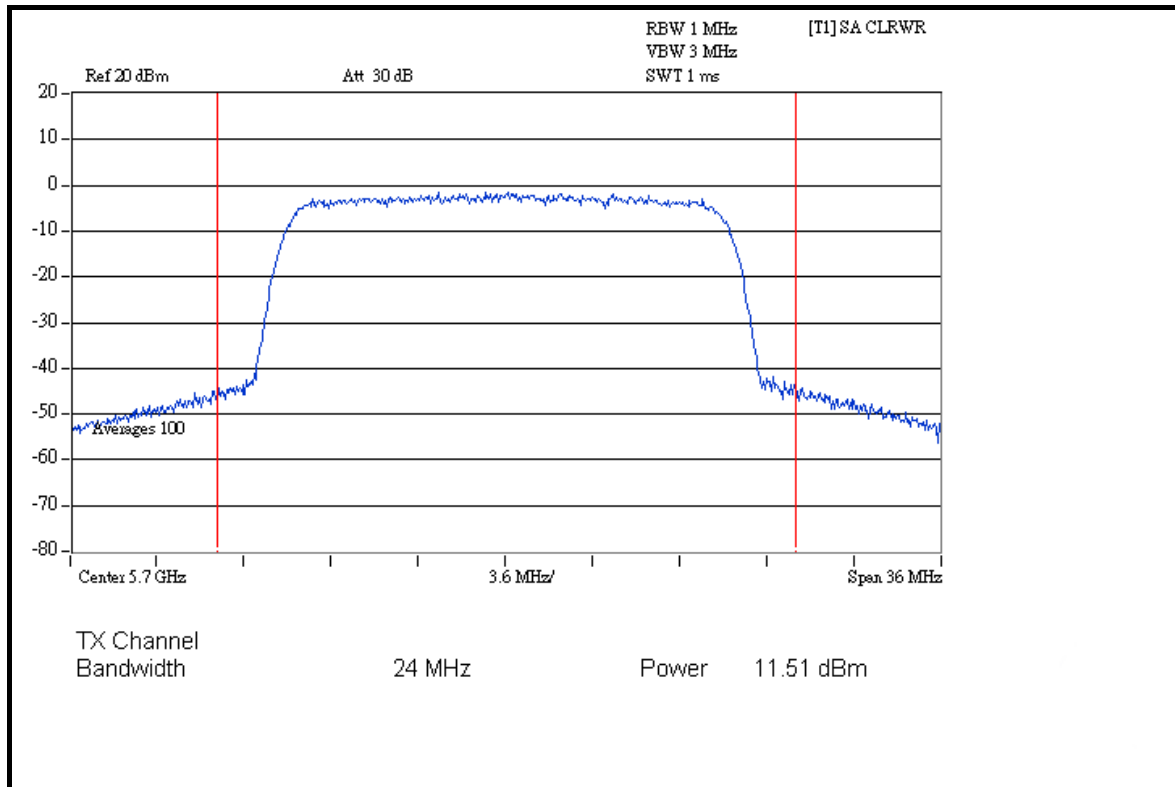



A D T

DRAFT 802.11n (40MHz) OFDM MODULATION

MODULATION TYPE	BPSK	TRANSFER RATE	15.0Mbps
INPUT POWER (SYSTEM)	120Vac, 60Hz	ENVIRONMENTAL CONDITIONS	26 deg.C, 65 %RH, 991hPa
TESTED BY	Brad Wu		

CHAN.	CHAN. FREQ. (MHz)	PEAK POWER OUTPUT (dBm)		TOTAL PEAK POWER (mW)	TOTAL PEAK POWER (dBm)	PEAK POWER LIMIT (dBm)	PASS / FAIL
		CHAIN 0	CHAIN 1				
54	5270	12.15	12.05	32.438	15.11	24	PASS
62	5310	12.09	12.14	32.549	15.13	24	PASS
102	5510	12.04	12.10	32.214	15.08	24	PASS
118	5590	12.11	12.12	32.549	15.13	24	PASS
134	5670	12.03	12.07	32.065	15.06	24	PASS



A D T

CHAIN 0: CH 54

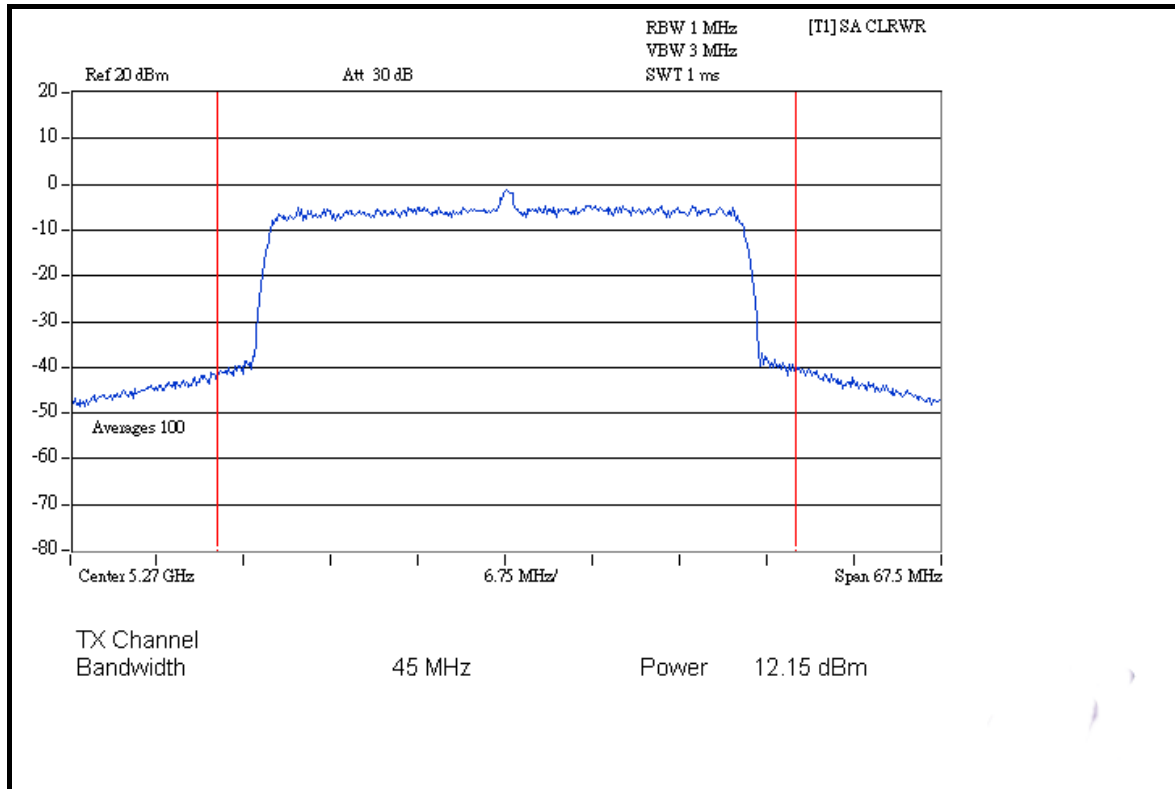

CH 62

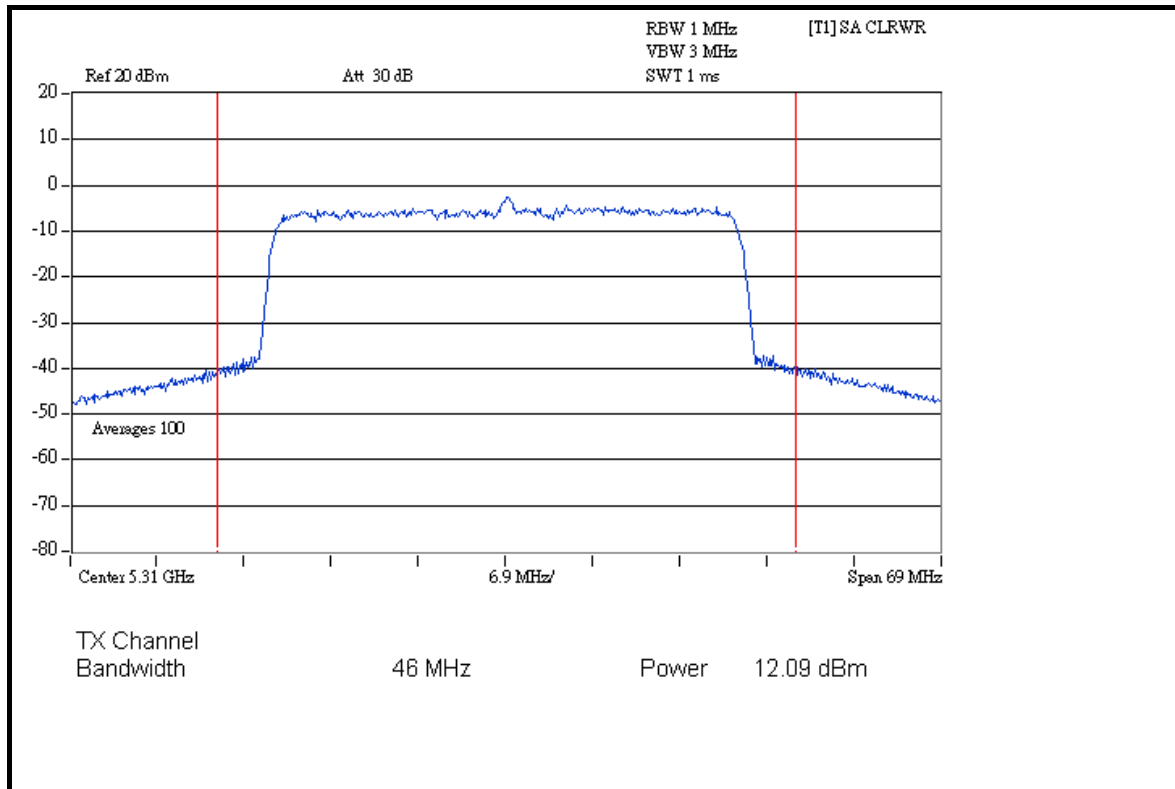



A D T

CH 102

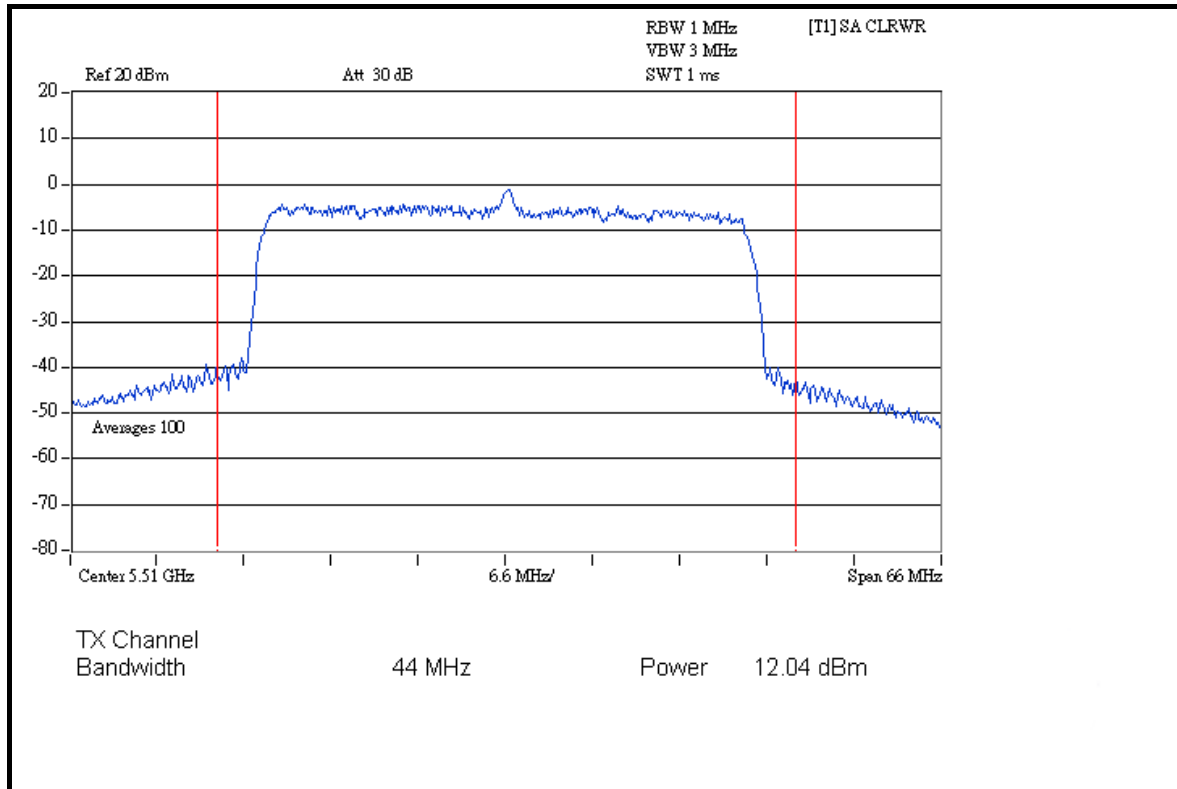

CH 118

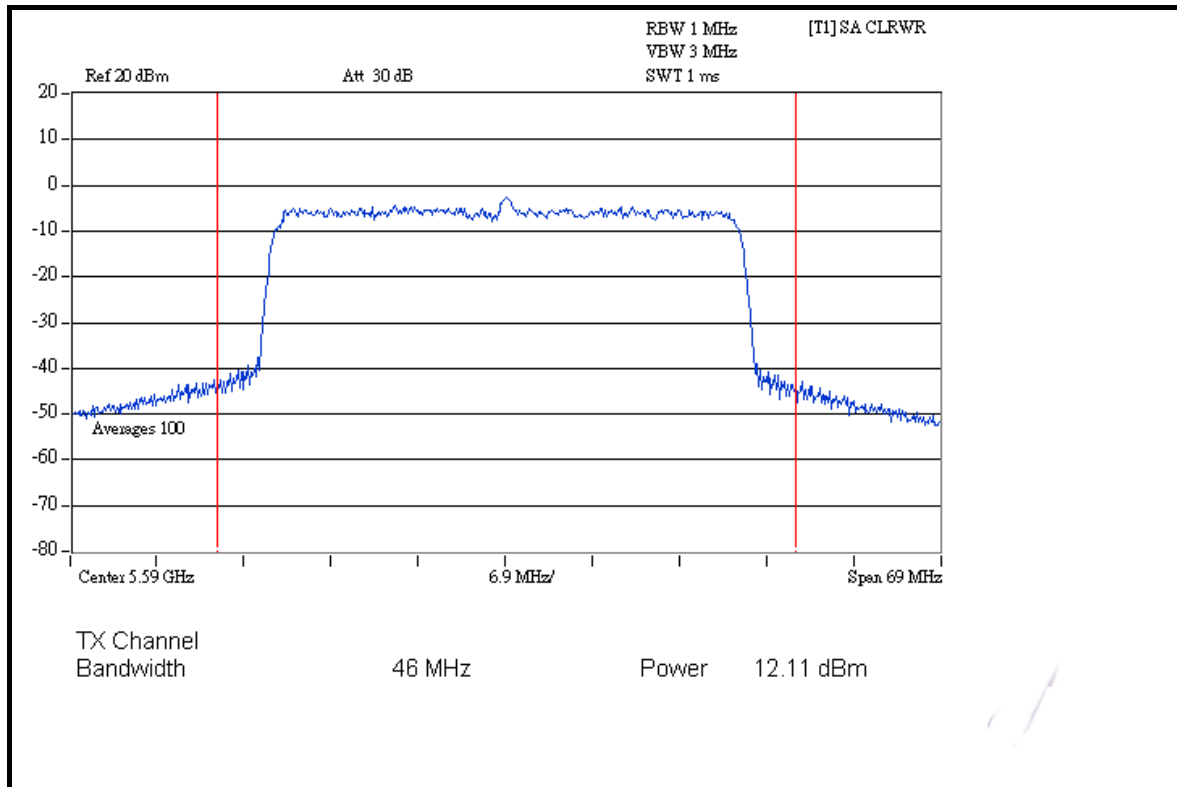



A D T

CH 134

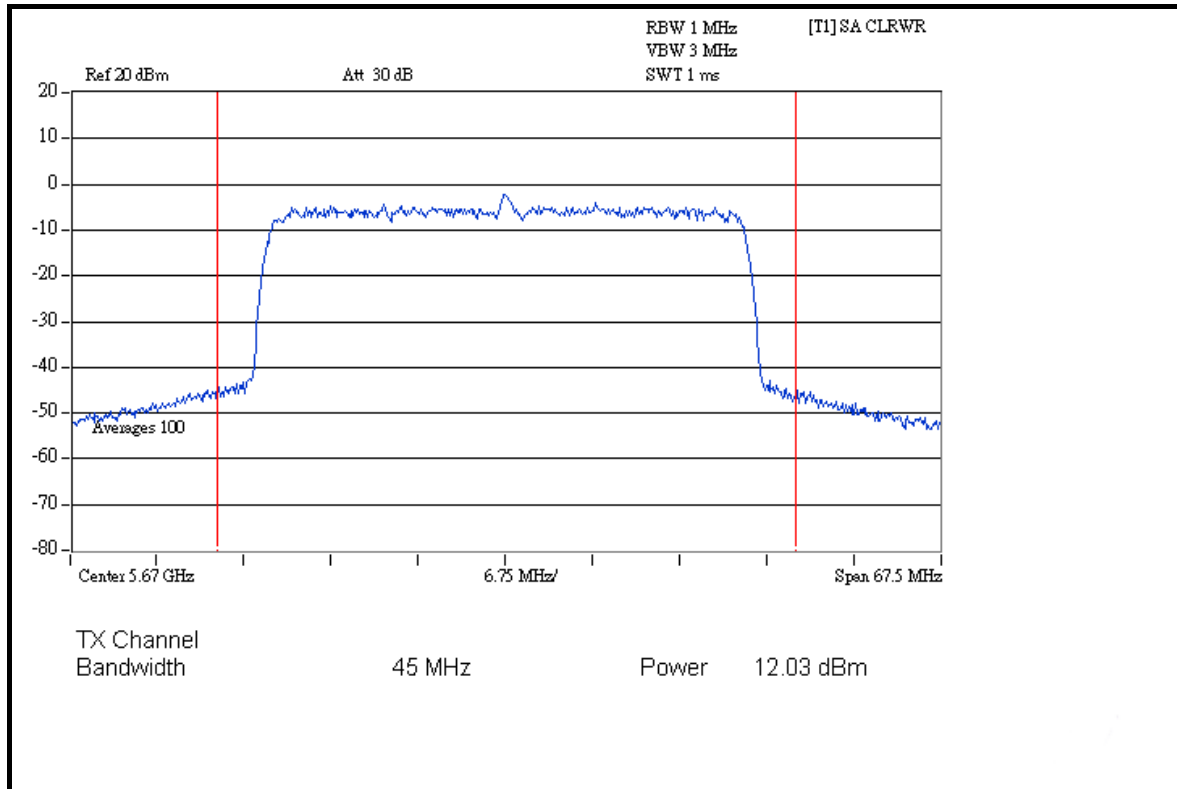

CHAIN 1: CH 54

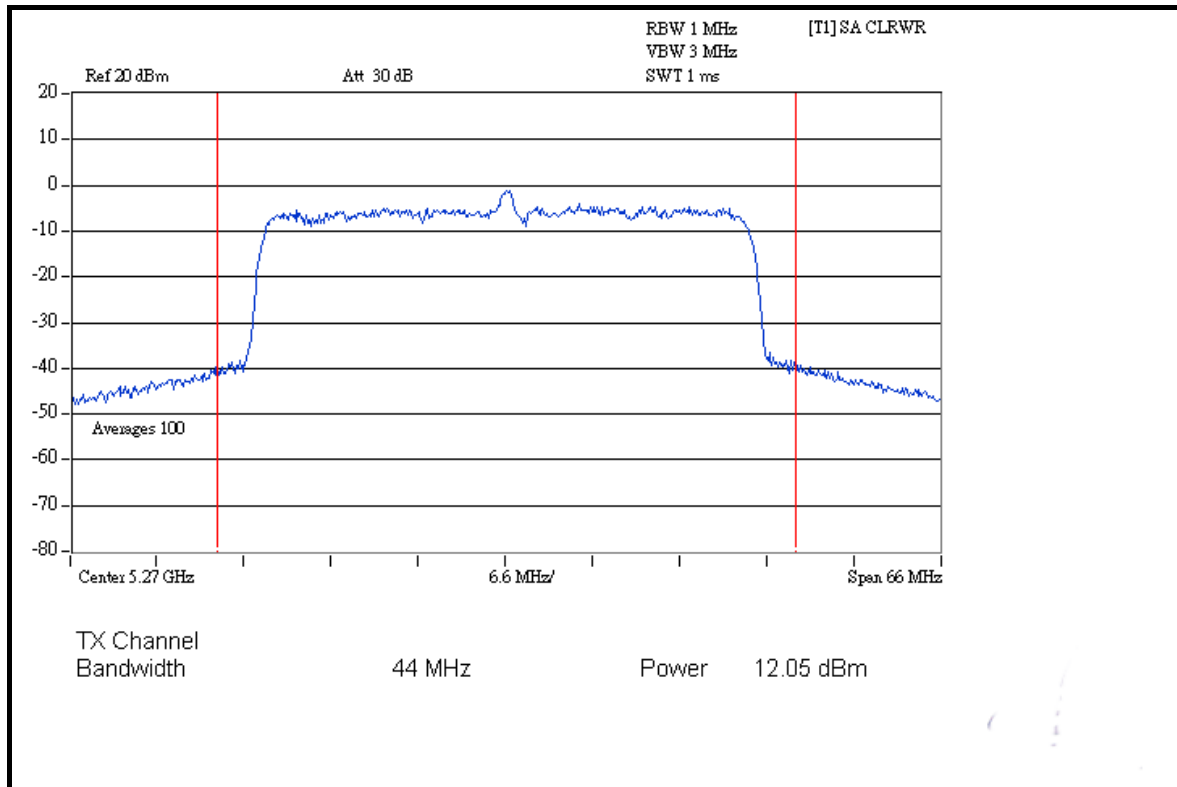



A D T

CH 62

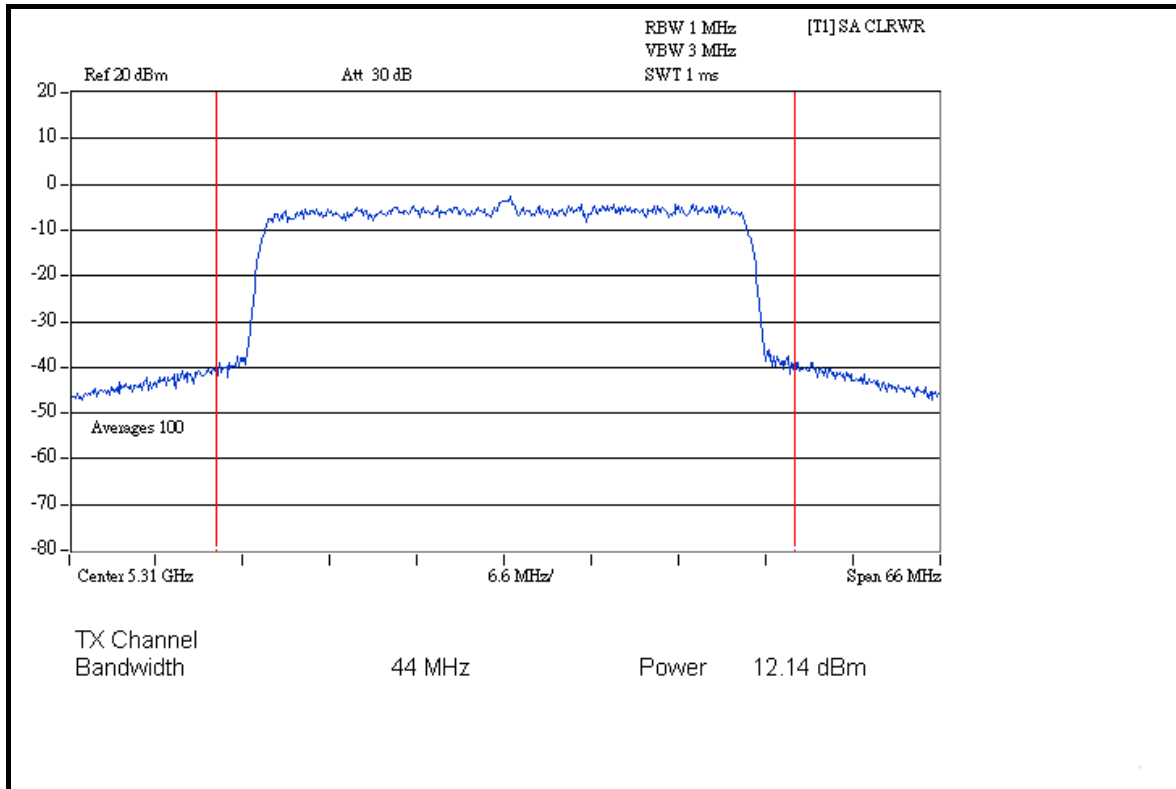

CH 102

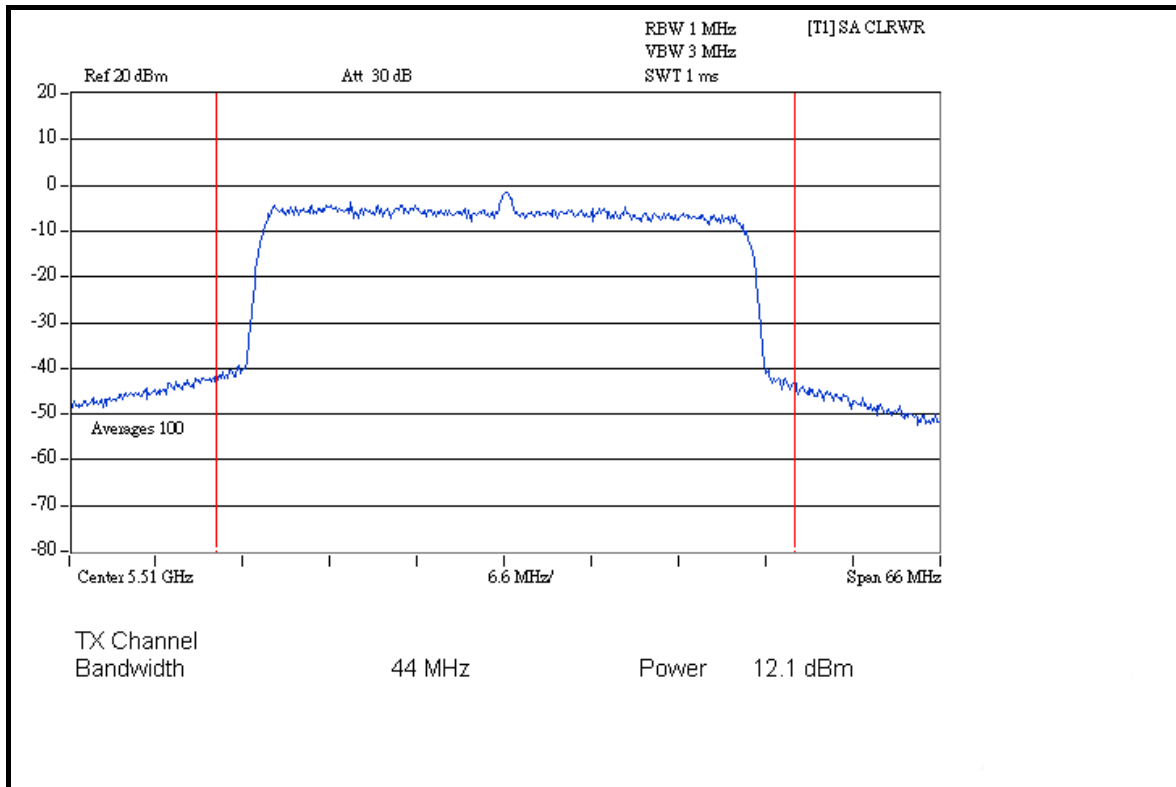



A D T

CH 118

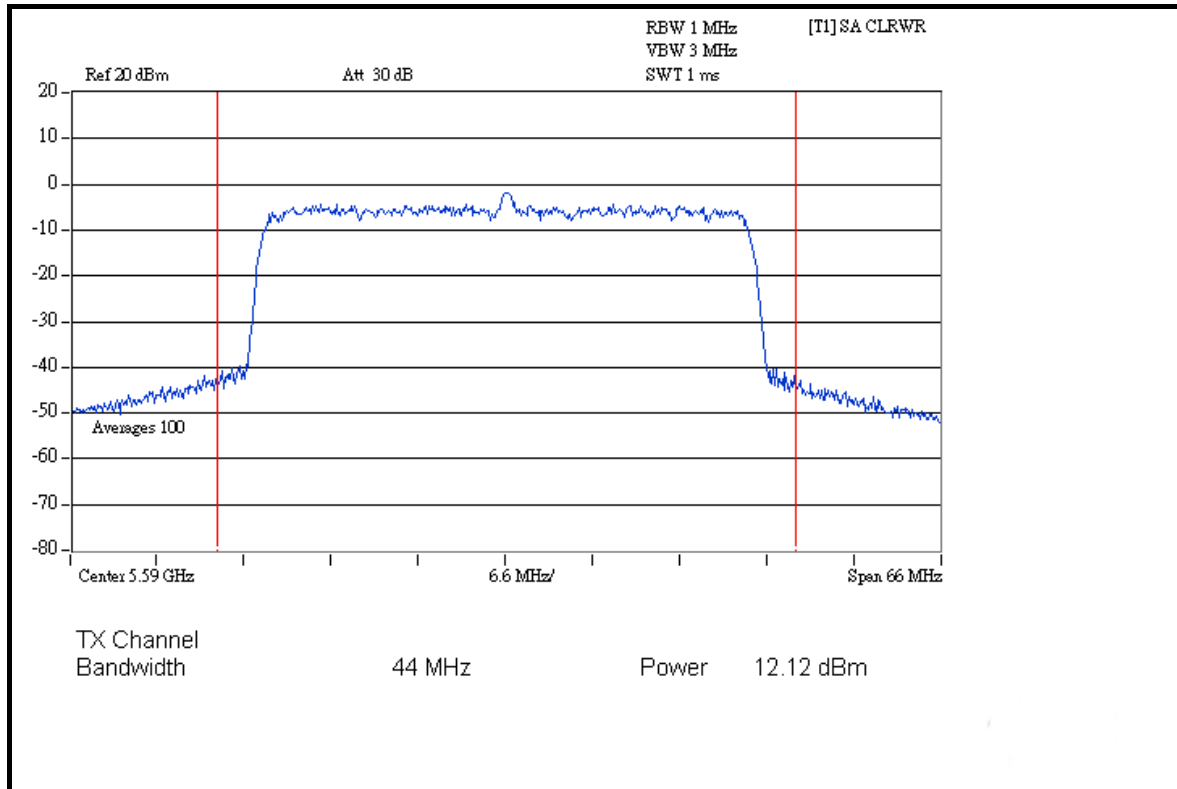

CH 134

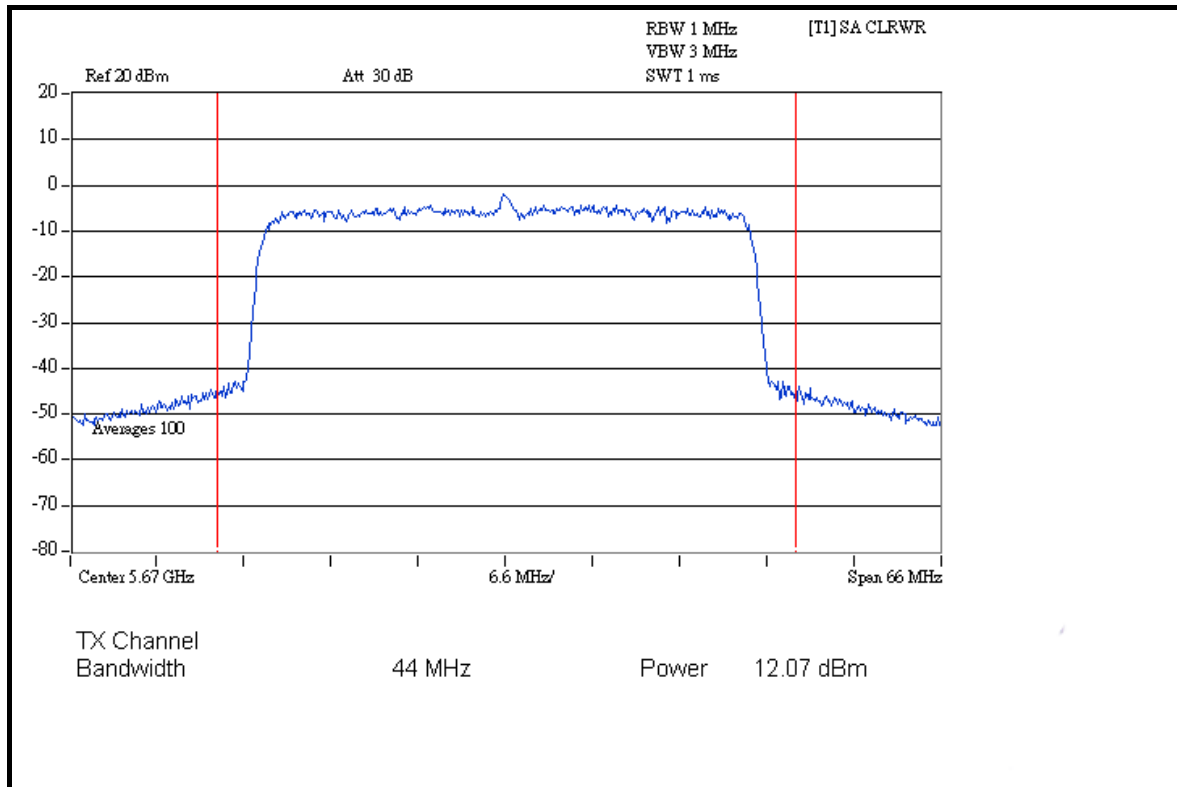



A D T

26dB OCCUPIED BANDWIDTH: 802.11a OFDM MODULATION

MODULATION TYPE	BPSK	TRANSFER RATE	6.0Mbps
INPUT POWER (SYSTEM)	120Vac, 60Hz	ENVIRONMENTAL CONDITIONS	26 deg.C, 67 %RH, 991hPa
TESTED BY	Brad Wu		

CHANNEL	CHANNEL FREQUENCY (MHz)	26dBc OCCUPIED BANDWIDTH (MHz)	PASS / FAIL
52	5260	22.32	PASS
60	5300	22.66	PASS
64	5320	23.19	PASS
100	5500	22.78	PASS
120	5600	23.32	PASS
140	5700	22.99	PASS



A D T

CH 52

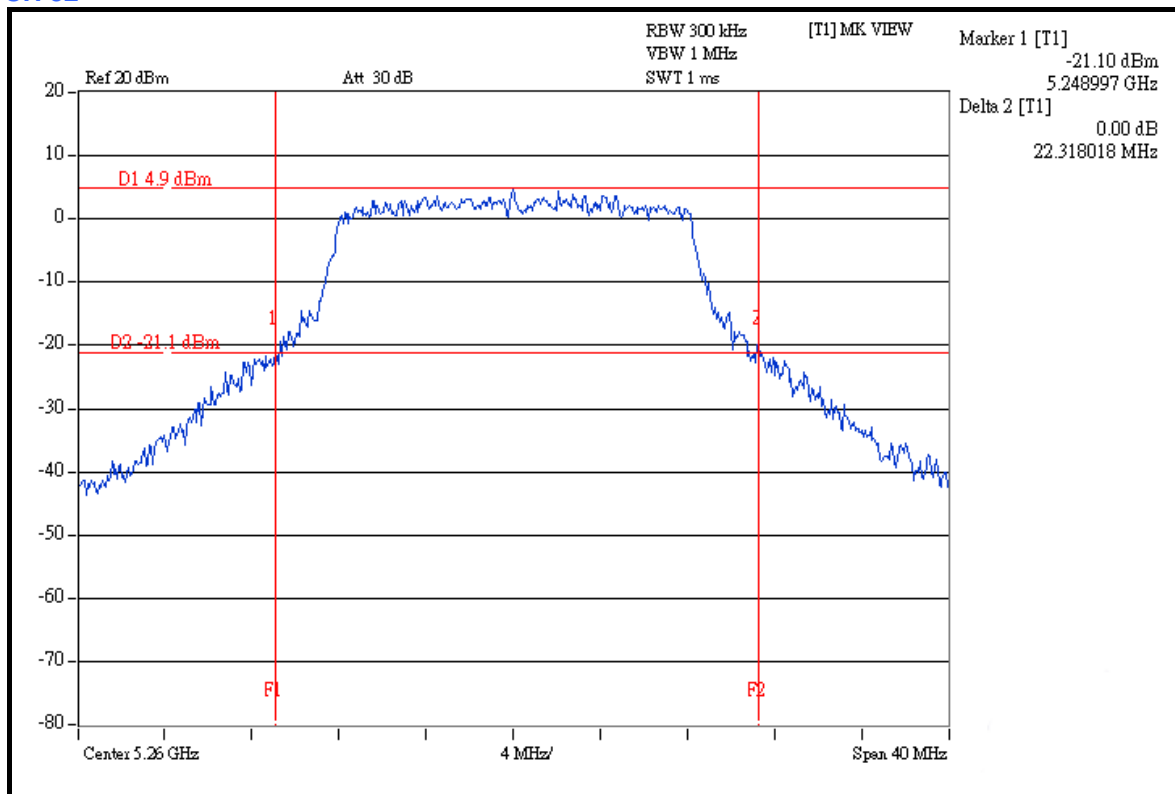

CH 60

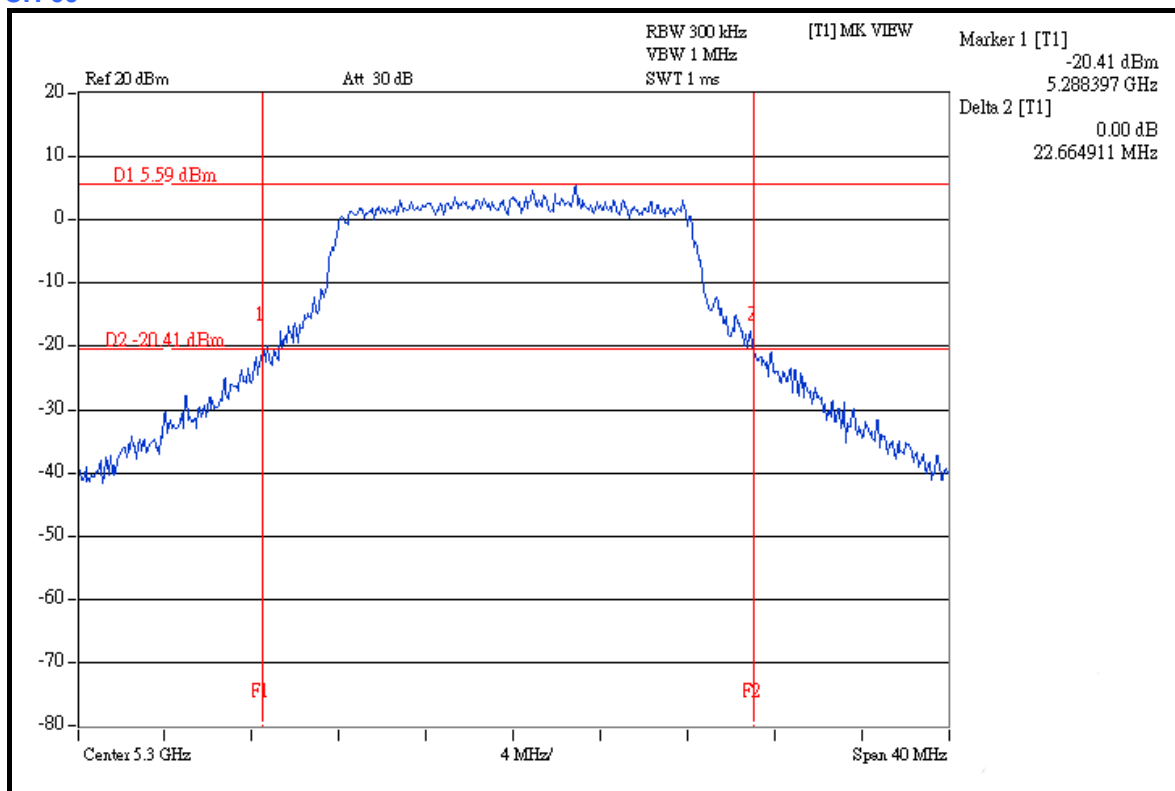



A D T

CH 64

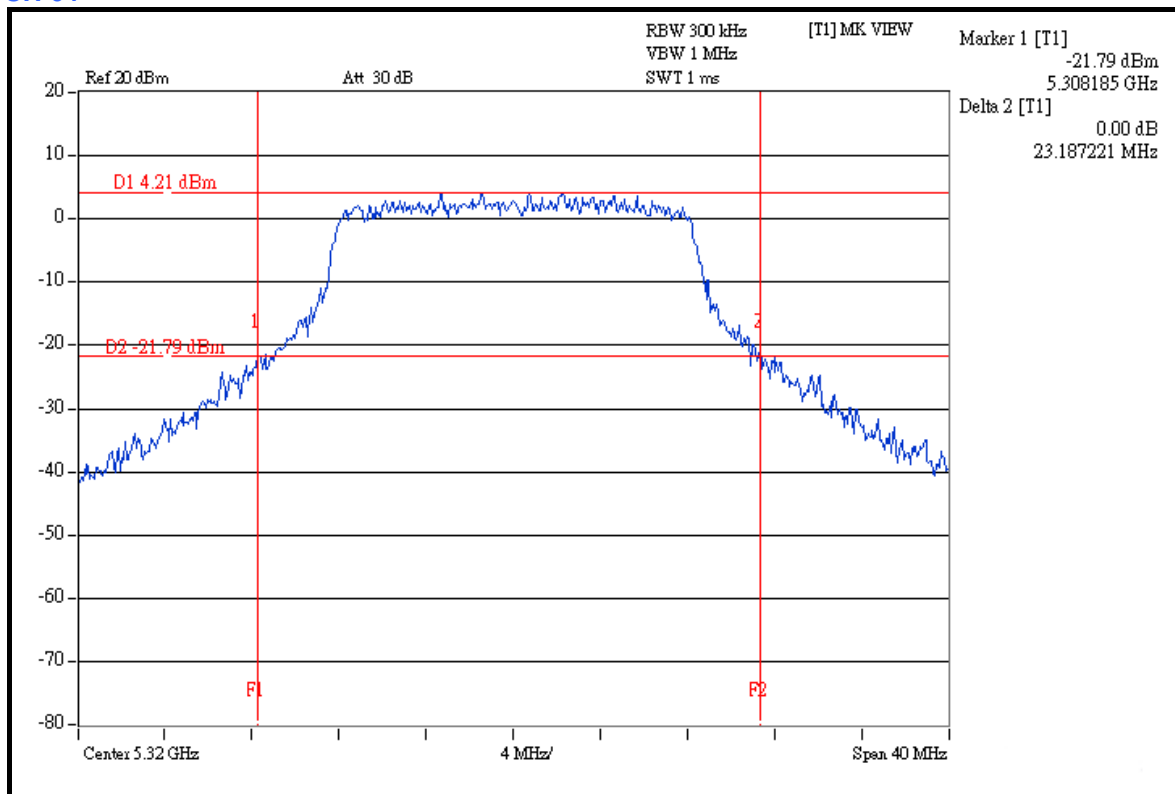

CH 100

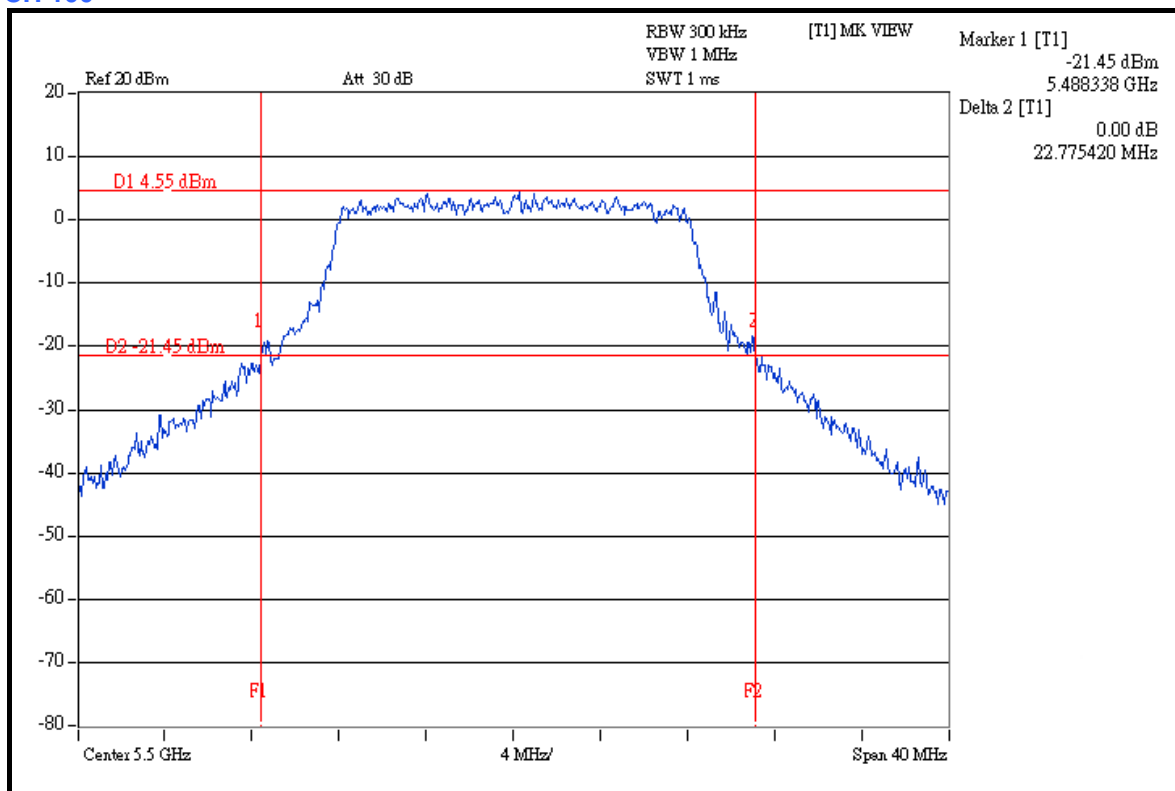



A D T

CH 120

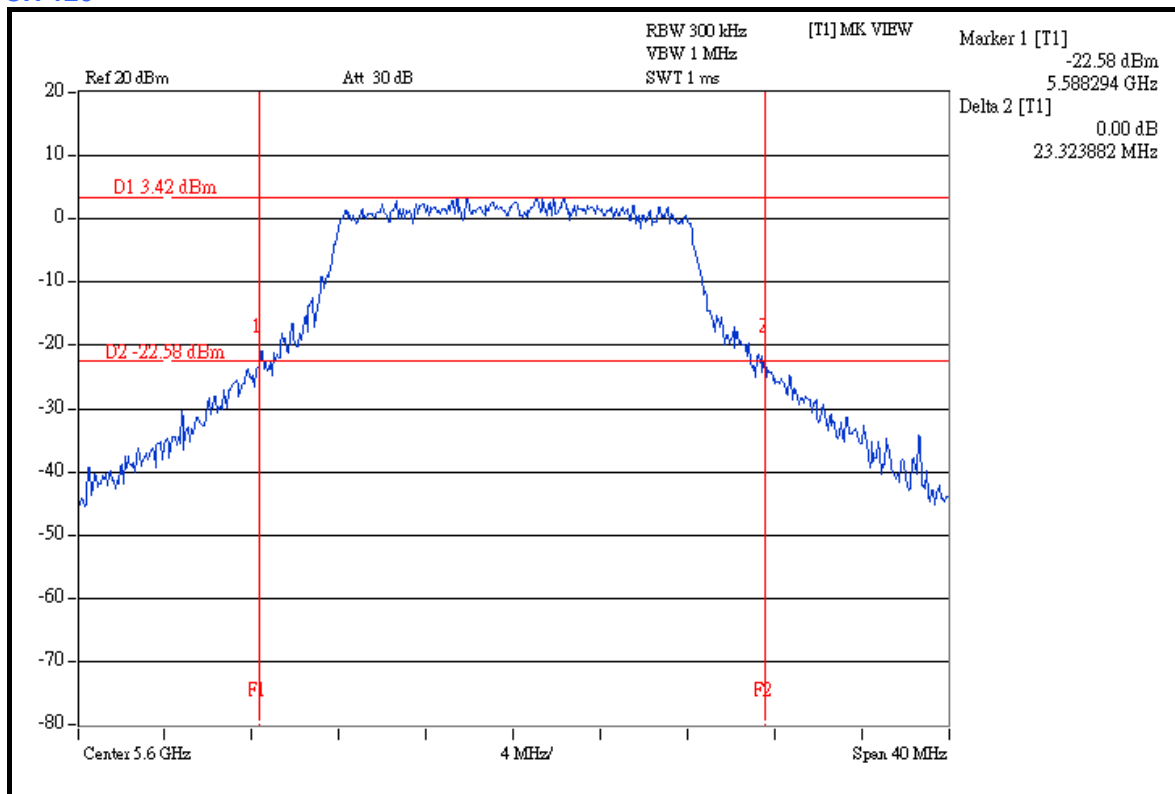

CH 140

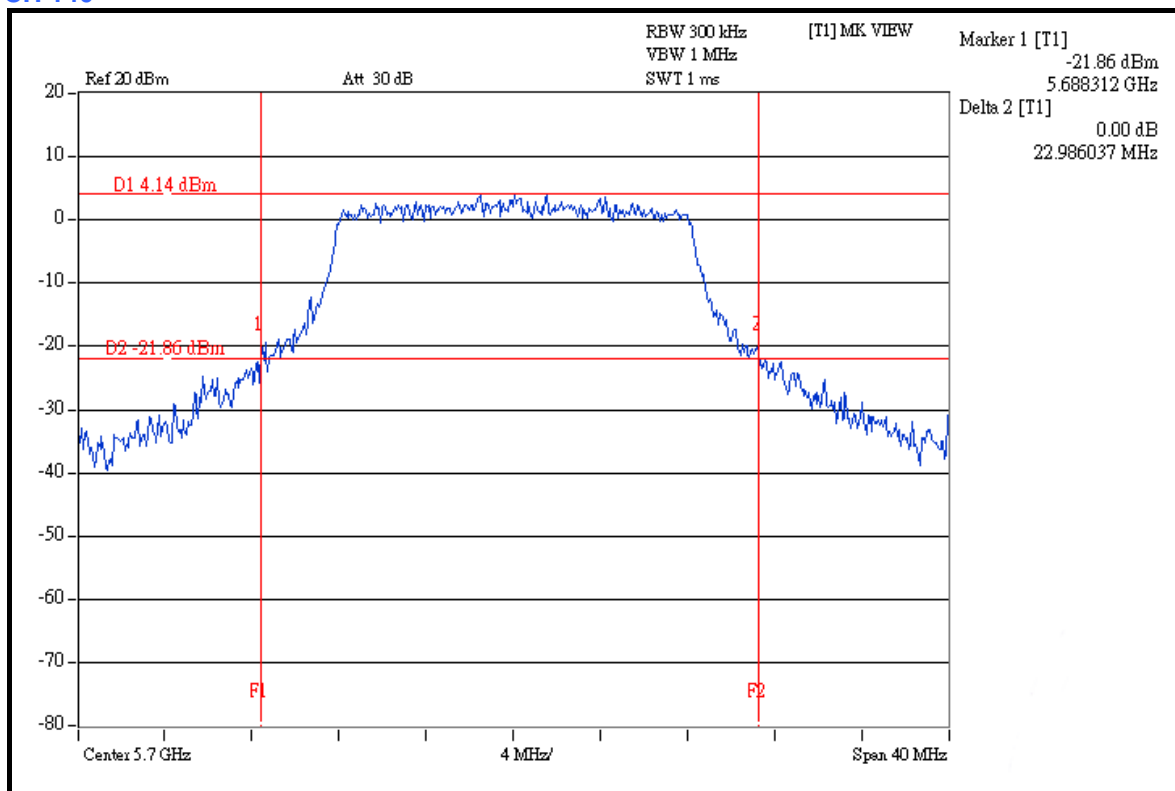



A D T

DRAFT 802.11n (20MHz) OFDM MODULATION

MODULATION TYPE	BPSK	TRANSFER RATE	7.2Mbps
INPUT POWER (SYSTEM)	120Vac, 60Hz	ENVIRONMENTAL CONDITIONS	26 deg.C, 67 %RH, 991hPa
TESTED BY	Brad Wu		

CHANNEL	CHANNEL FREQUENCY (MHz)	26dBc OCCUPIED BANDWIDTH (MHz)		PASS / FAIL
		CHAIN 0	CHAIN 1	
52	5260	23.95	23.26	PASS
60	5300	24.94	24.01	PASS
64	5320	23.05	25.69	PASS
100	5500	24.37	23.81	PASS
120	5600	23.58	23.75	PASS
140	5700	23.28	23.14	PASS



A D T

CHAIN 0: CH 52

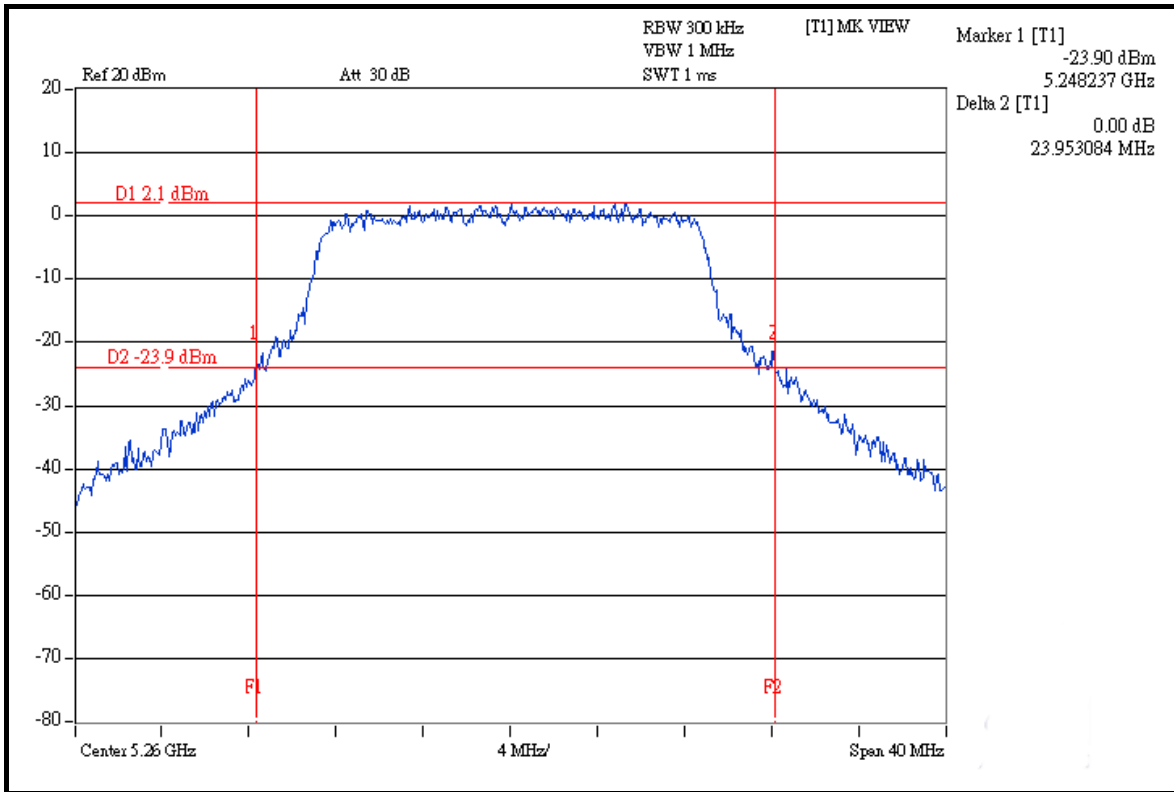

CH 60

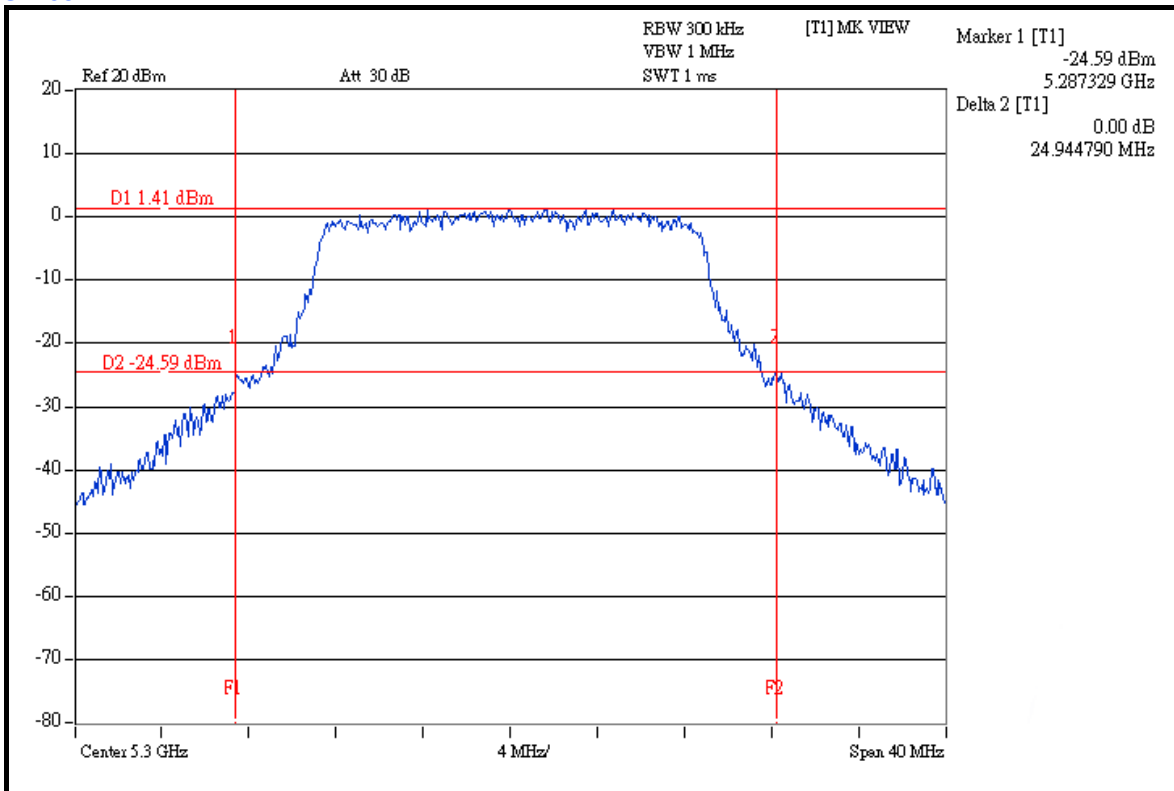



A D T

CH 64

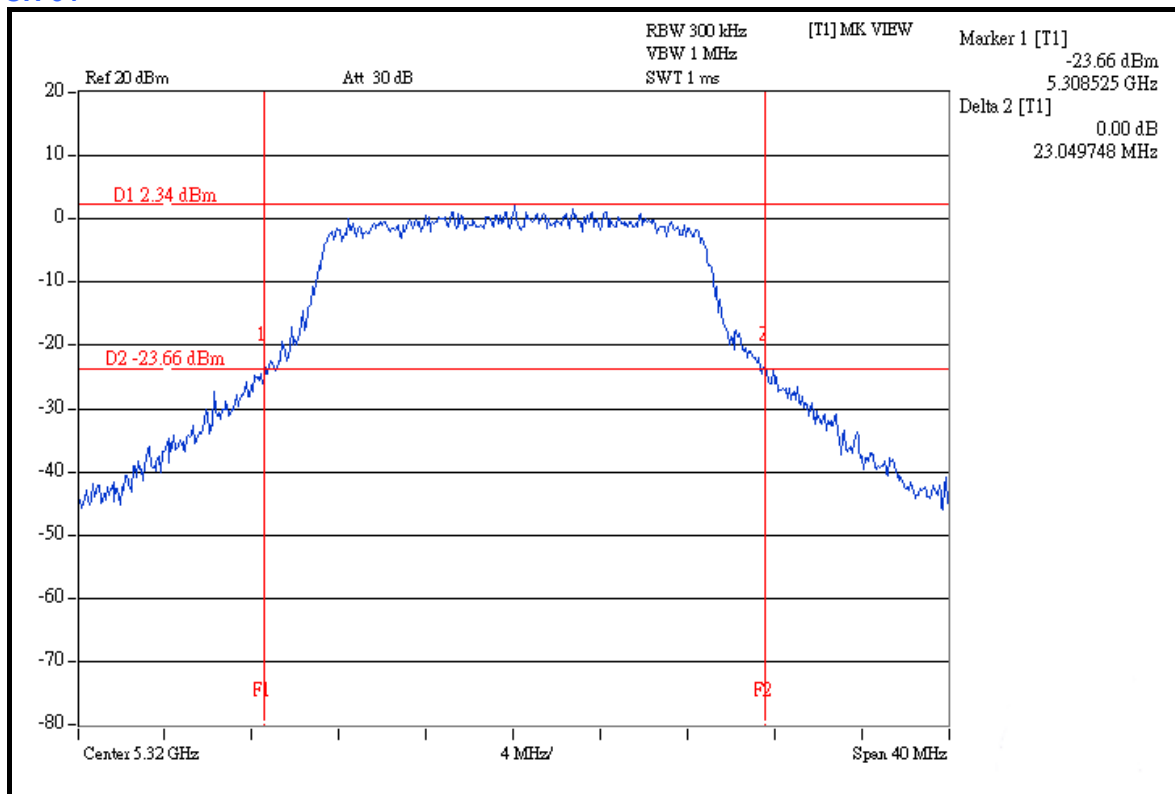

CH 100

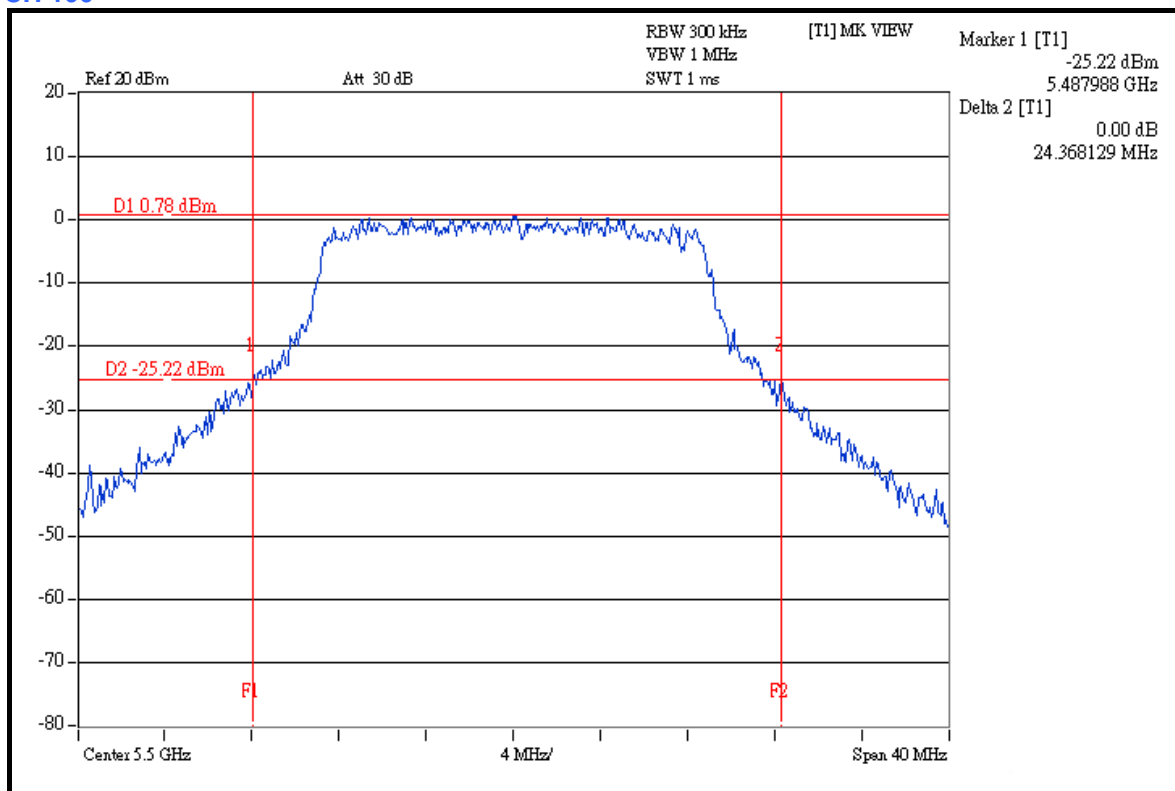



A D T

CH 120

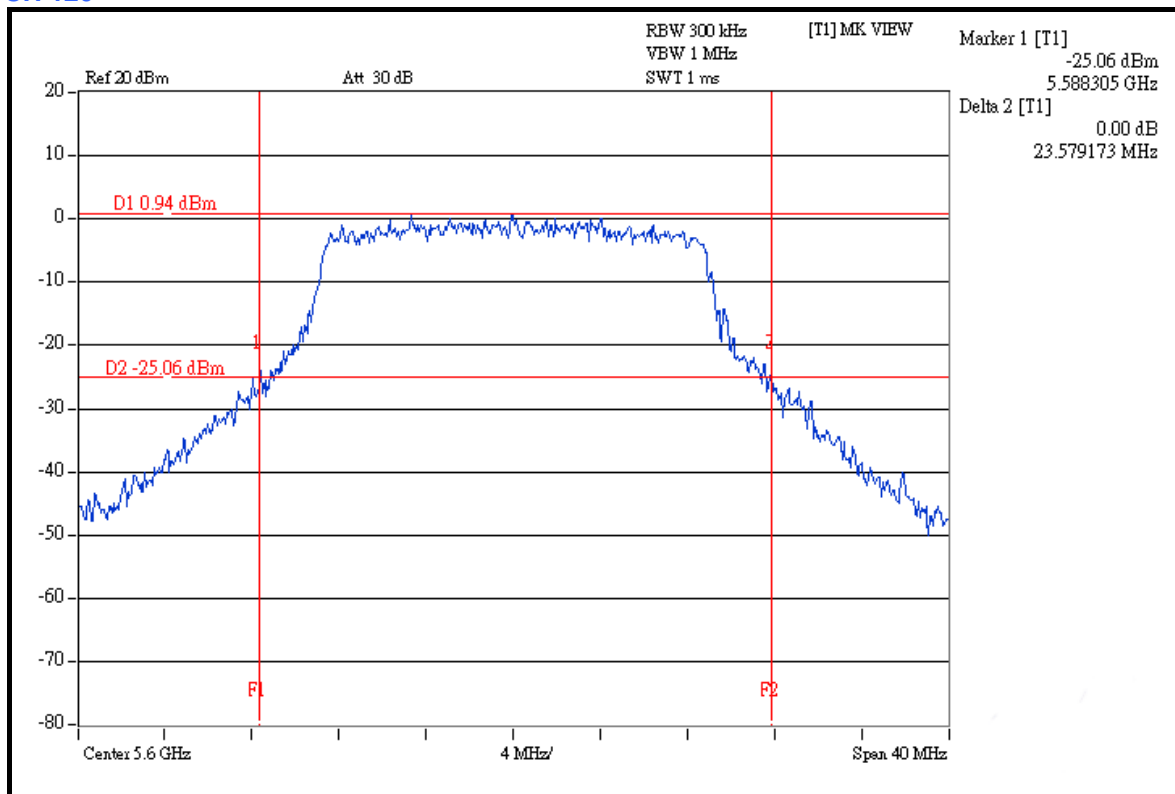

CH 140

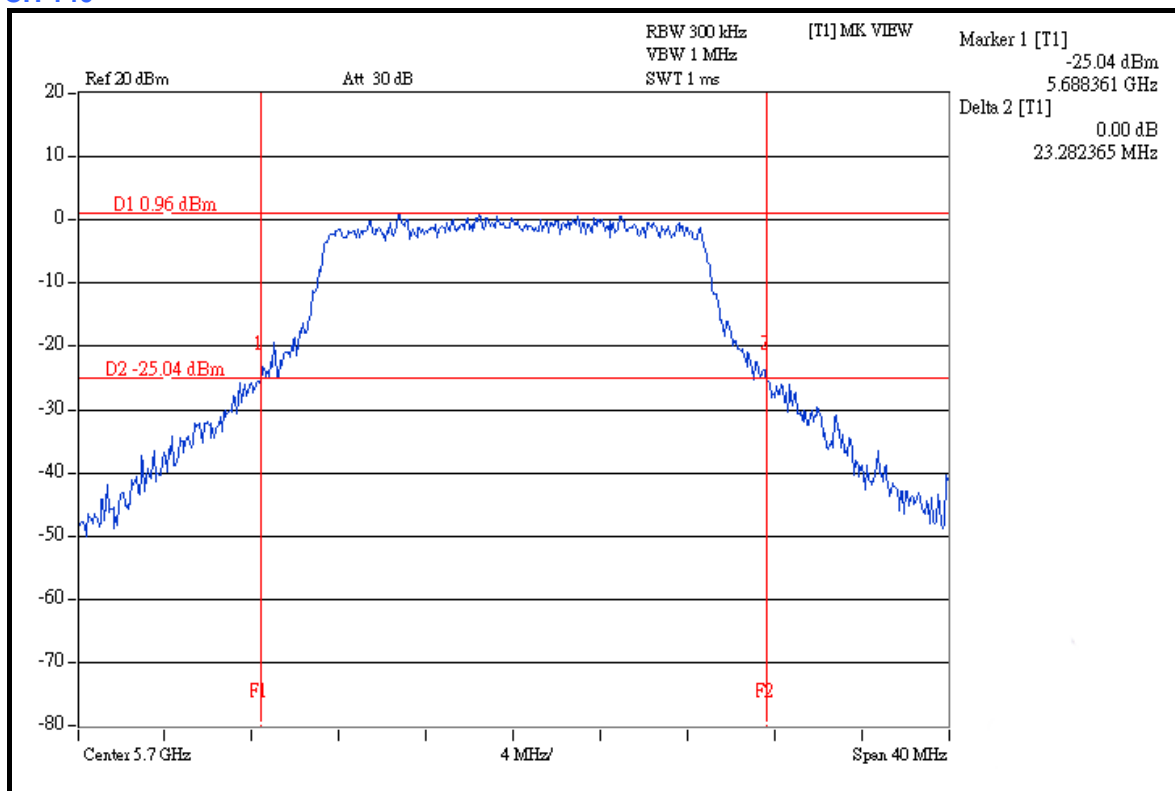



A D T

CHAIN 1: CH 52

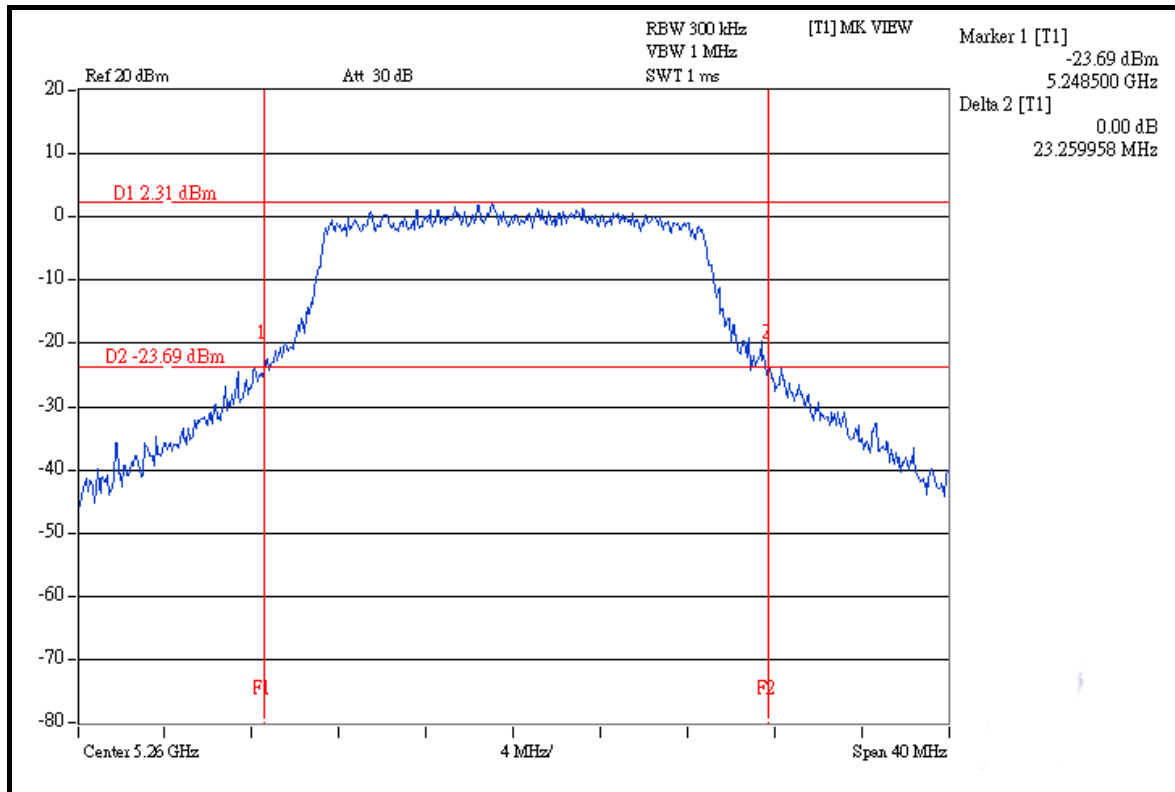

CH 60

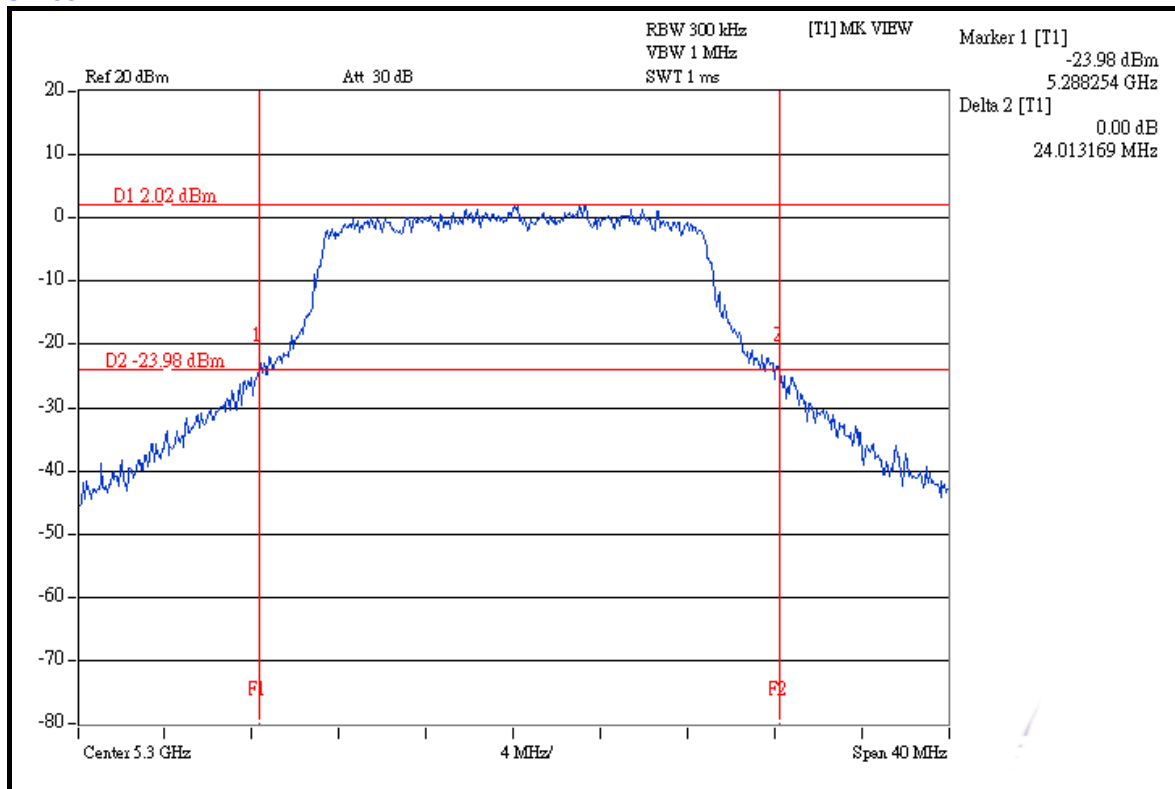



A D T

CH 64

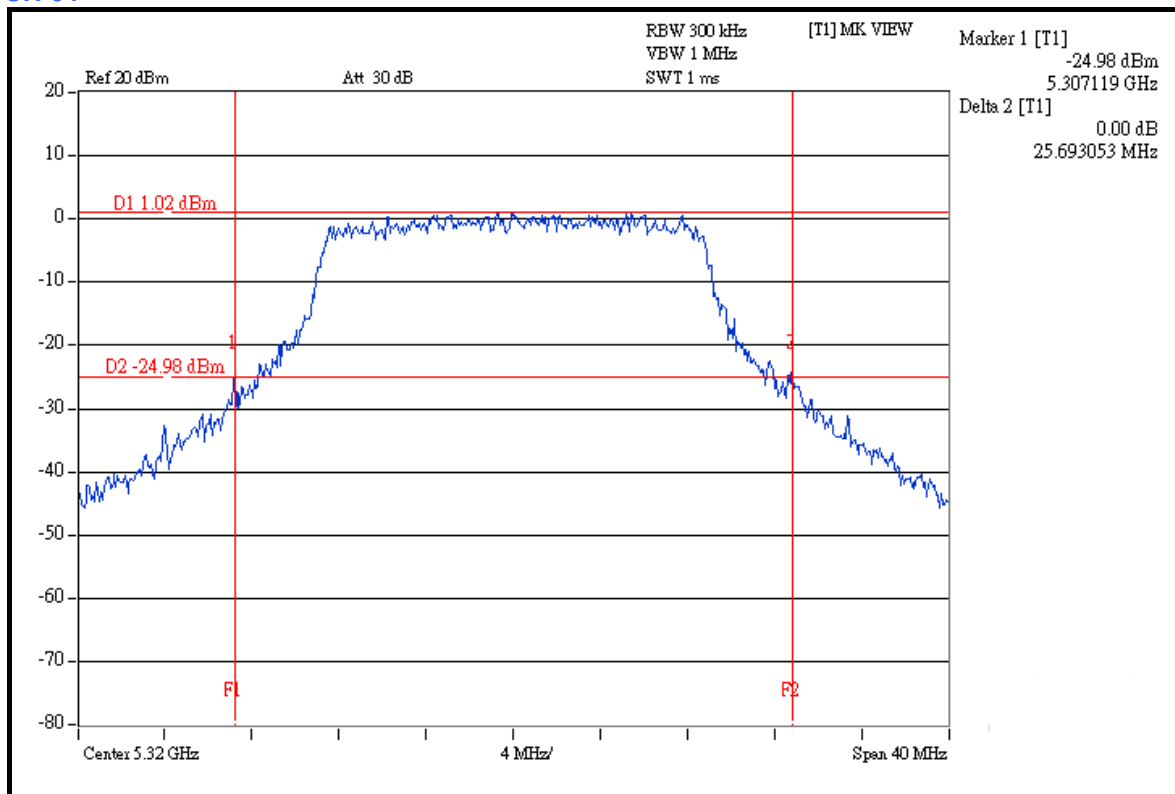

CH 100

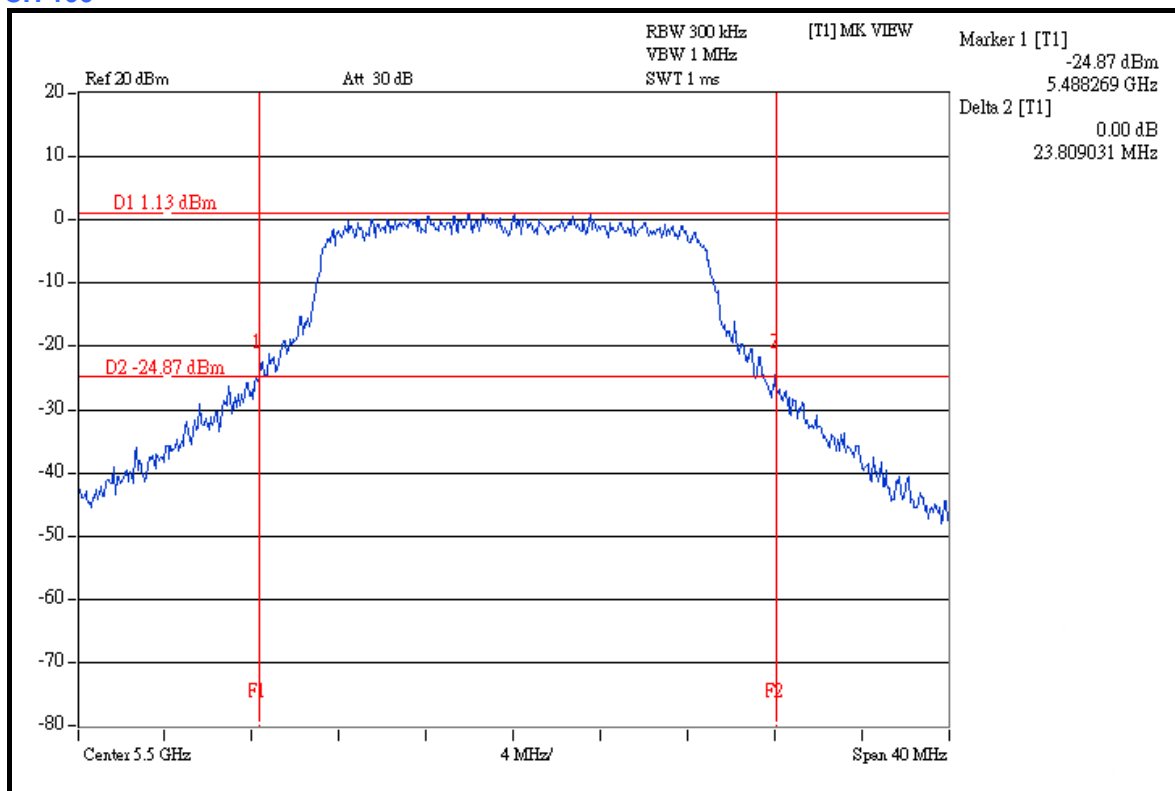



A D T

CH 120

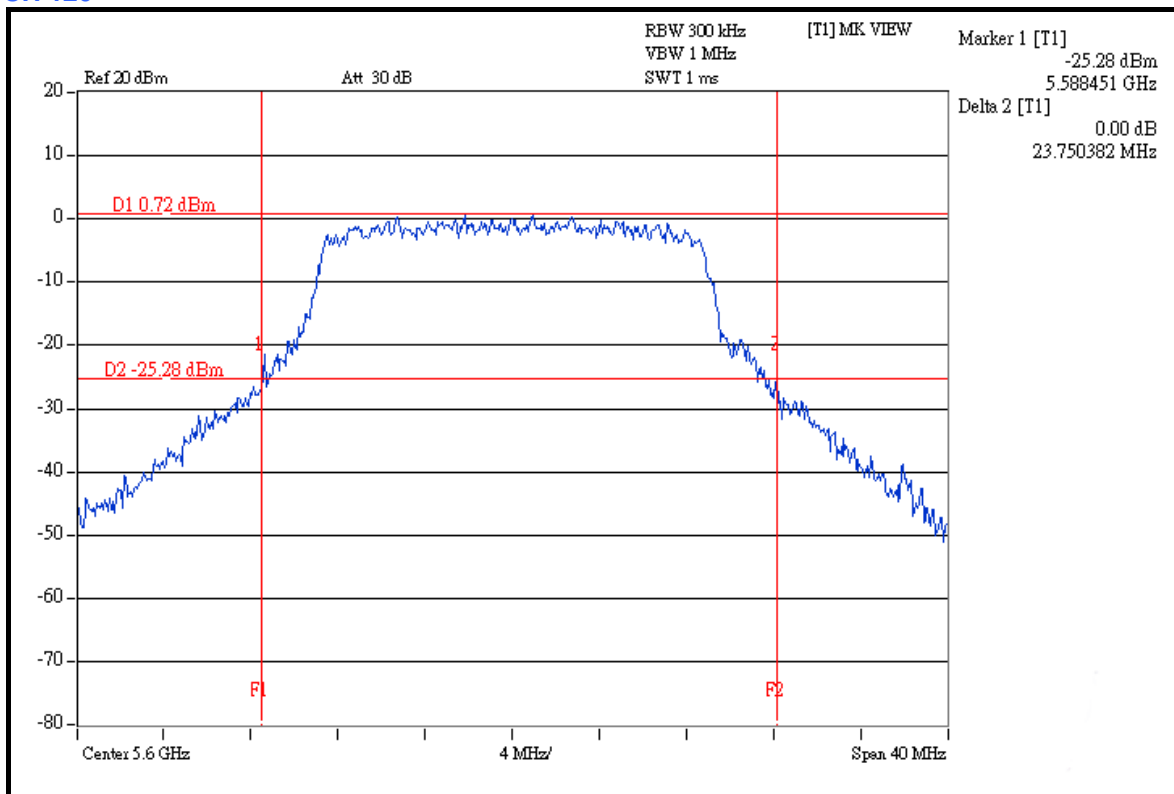

CH 140

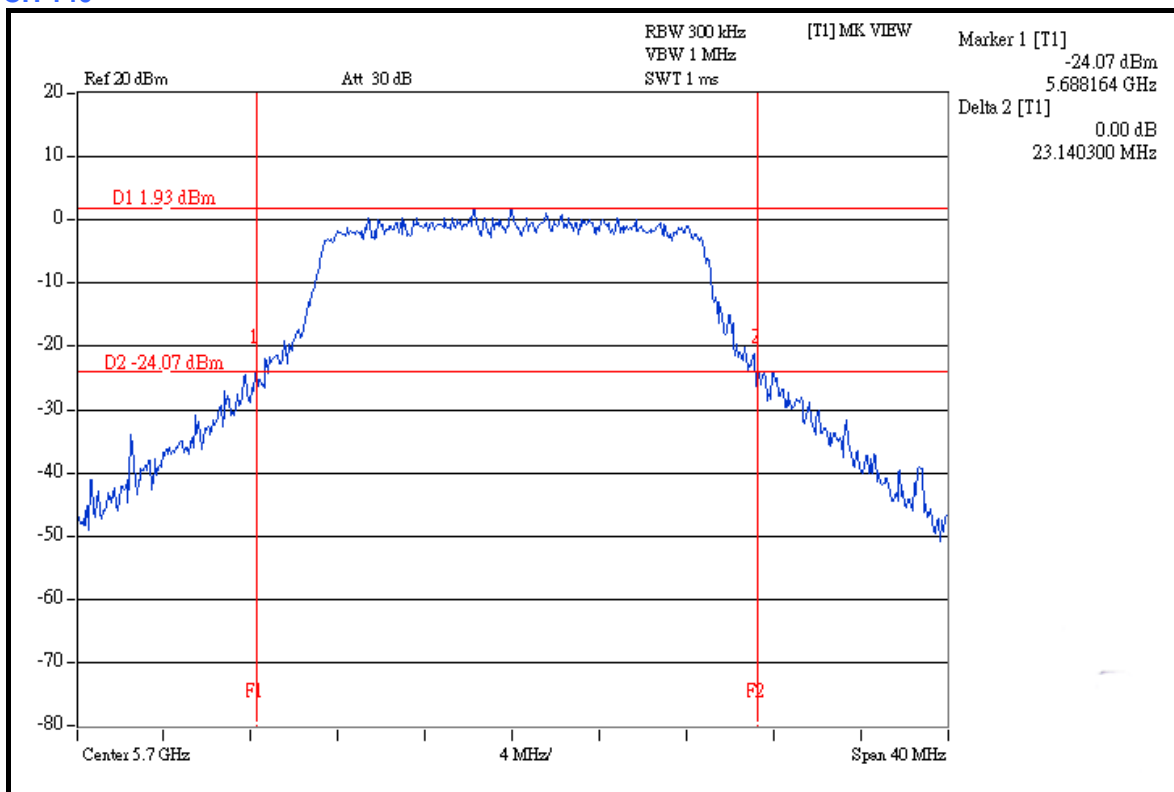



A D T

DRAFT 802.11n (40MHz) OFDM MODULATION

MODULATION TYPE	BPSK	TRANSFER RATE	15.0Mbps
INPUT POWER (SYSTEM)	120Vac, 60Hz	ENVIRONMENTAL CONDITIONS	26 deg.C, 65 %RH, 991hPa
TESTED BY	Brad Wu		

CHANNEL	CHANNEL FREQUENCY (MHz)	26dBc OCCUPIED BANDWIDTH (MHz)		PASS / FAIL
		CHAIN 0	CHAIN 1	
54	5270	44.02	43.33	PASS
62	5310	45.07	43.87	PASS
102	5510	43.55	43.13	PASS
118	5590	45.11	43.11	PASS
134	5670	44.51	43.29	PASS



A D T

CHAIN 0: CH 54

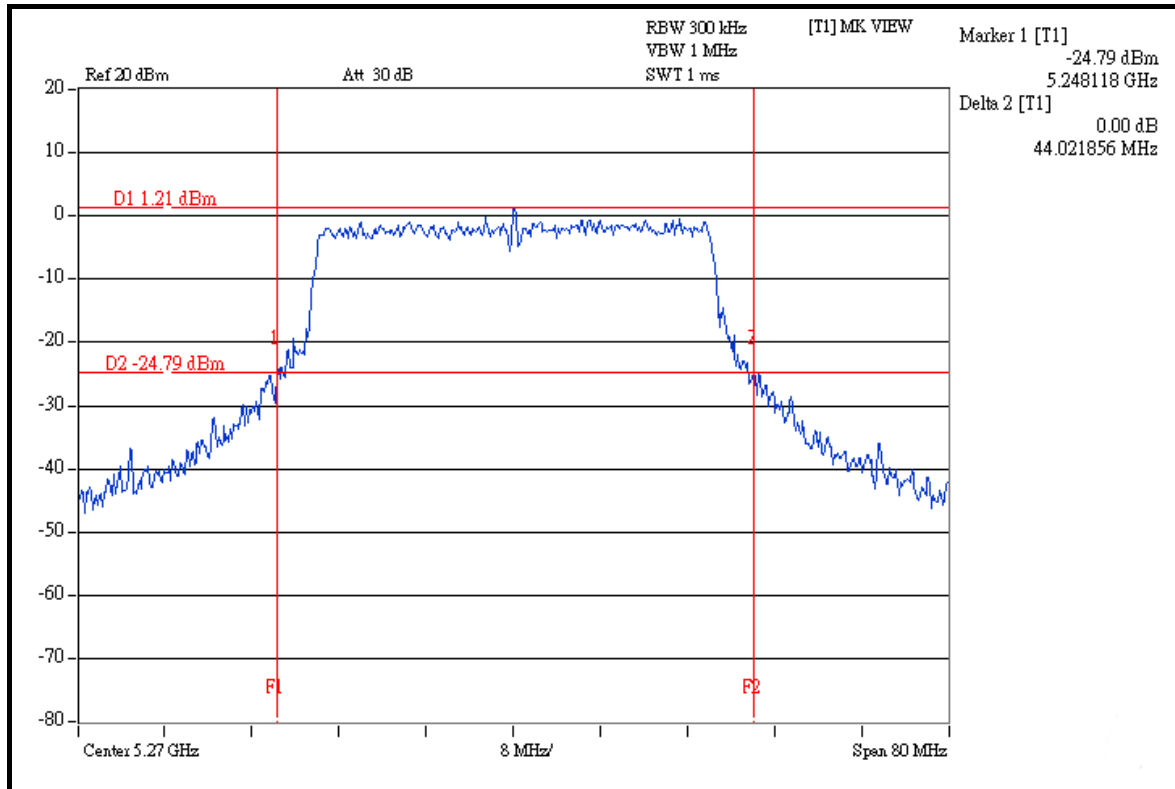

CH 62

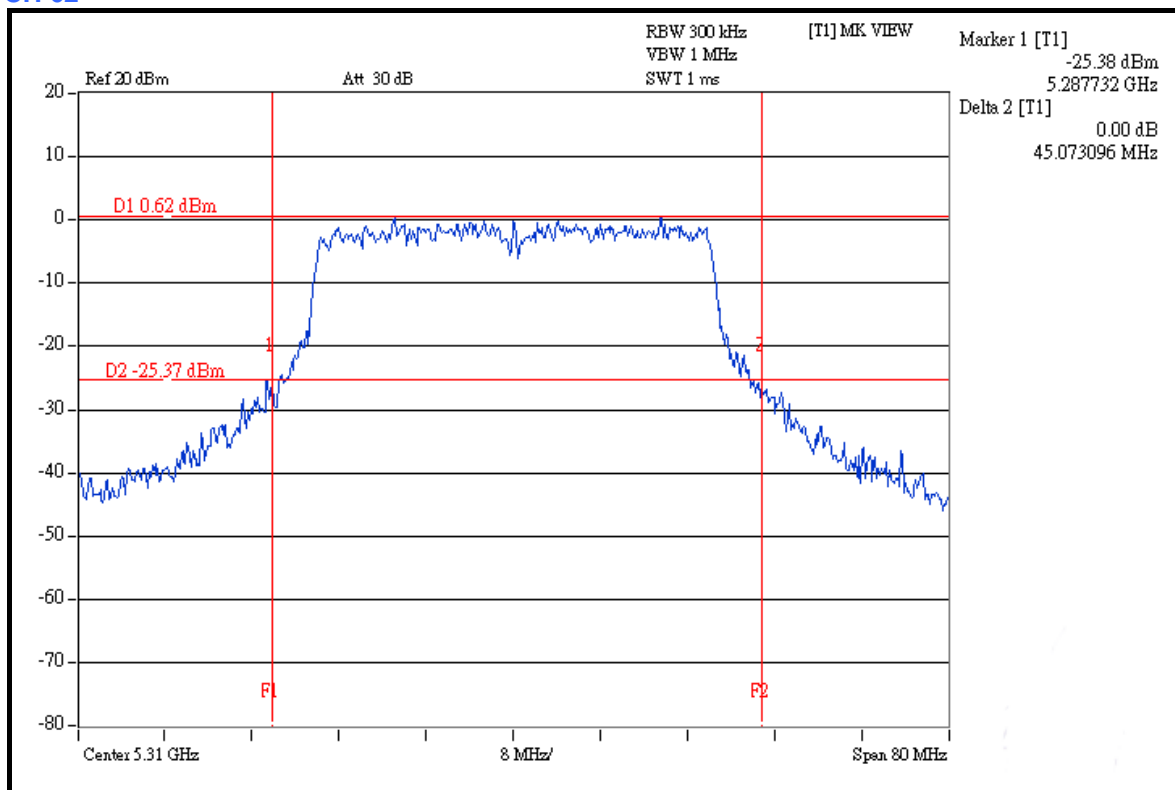



A D T

CH 102

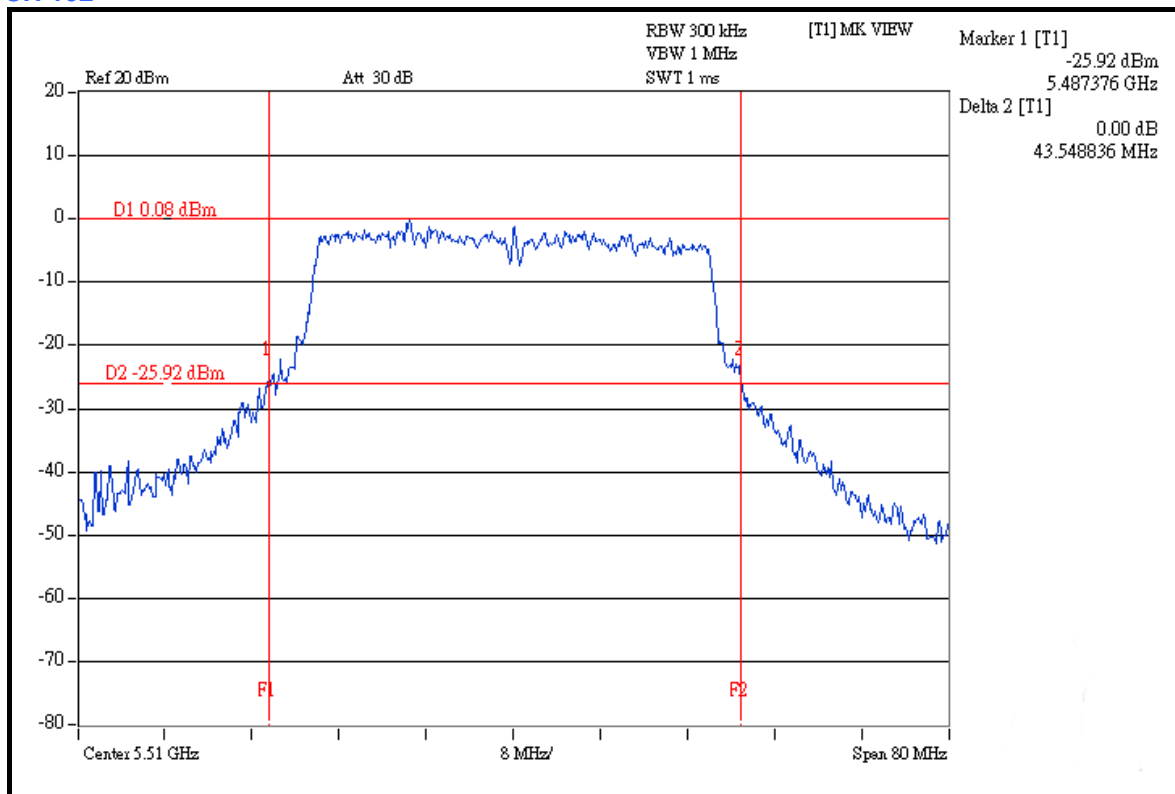

CH 118

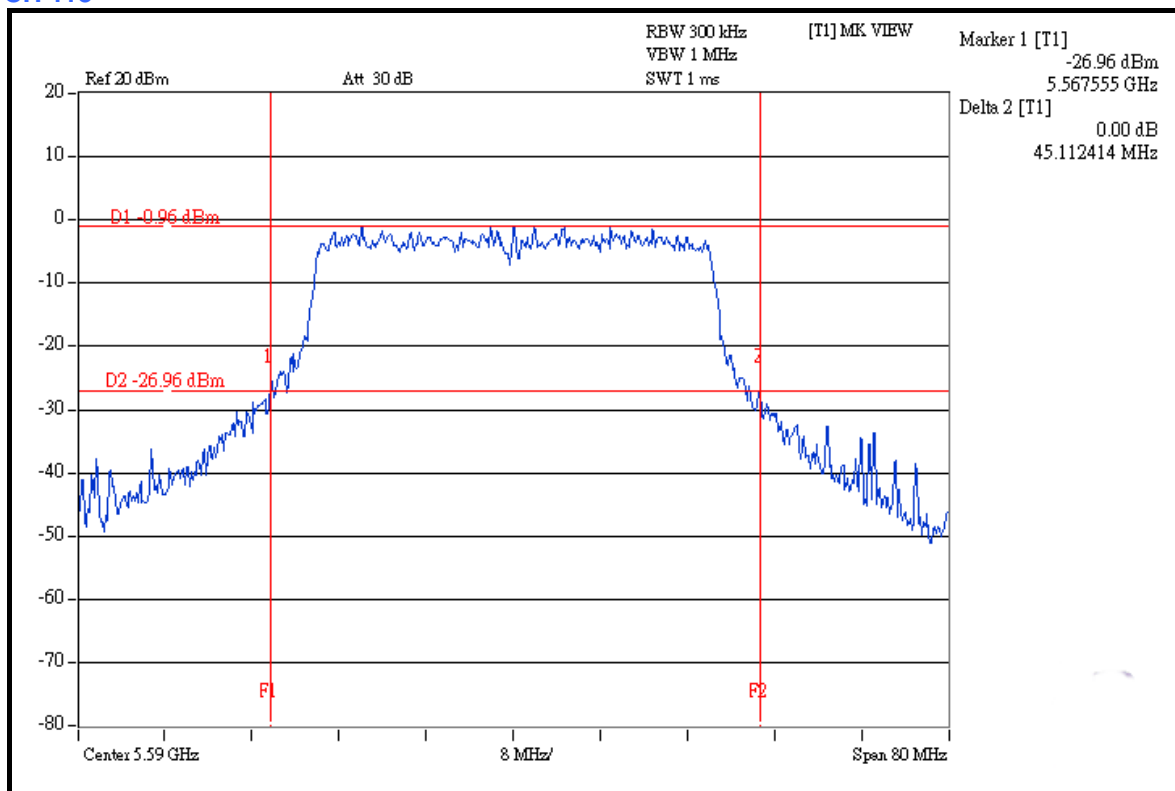



A D T

CH 134

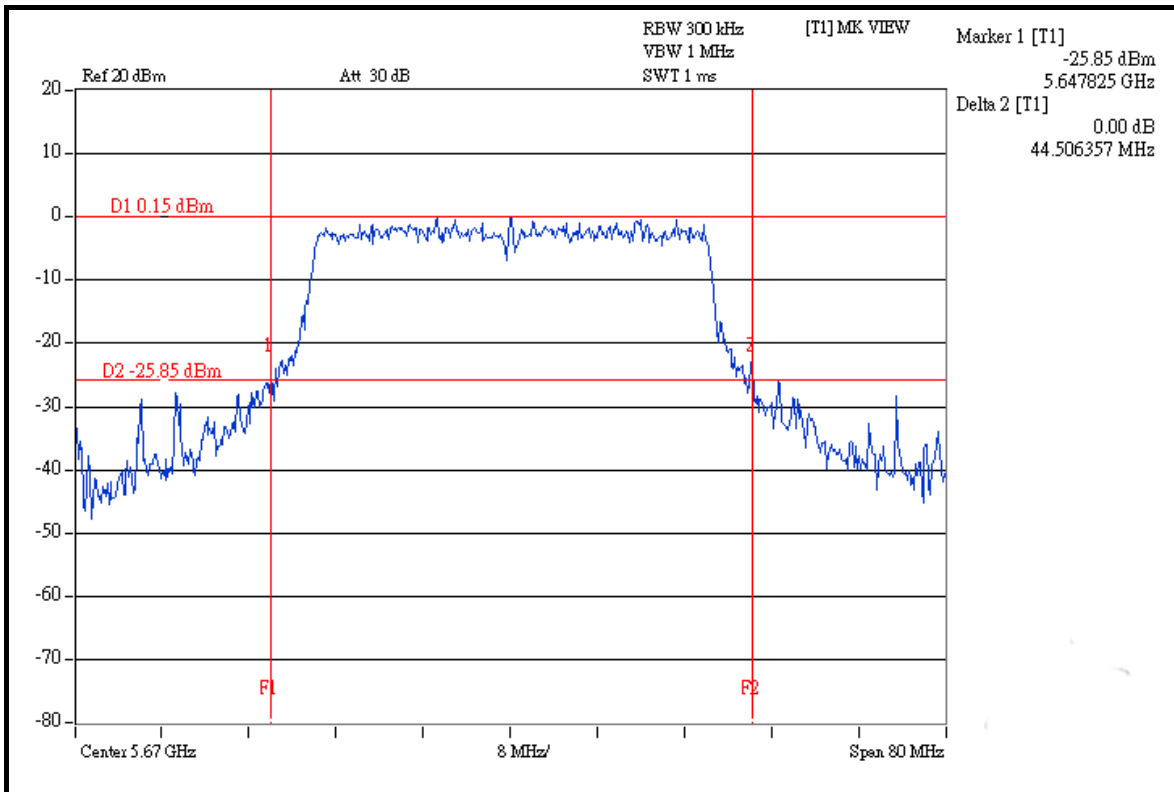

CHAIN 1: CH 54

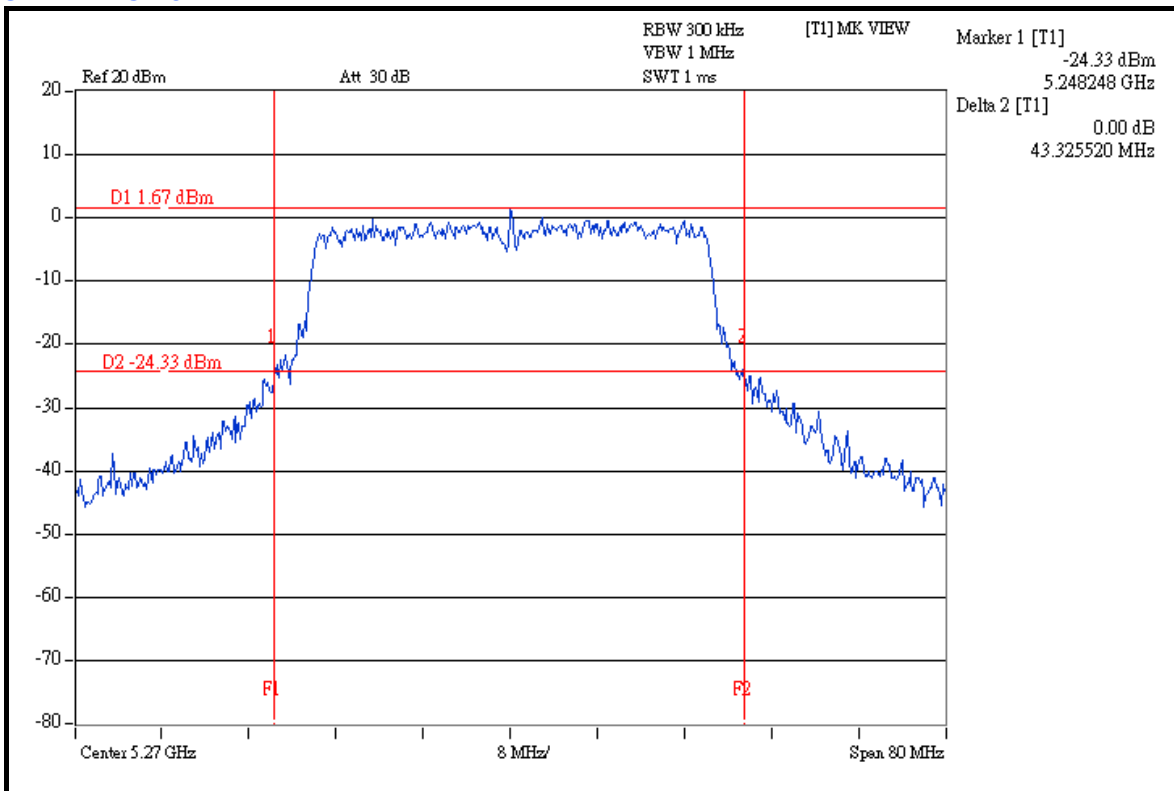



A D T

CH 62

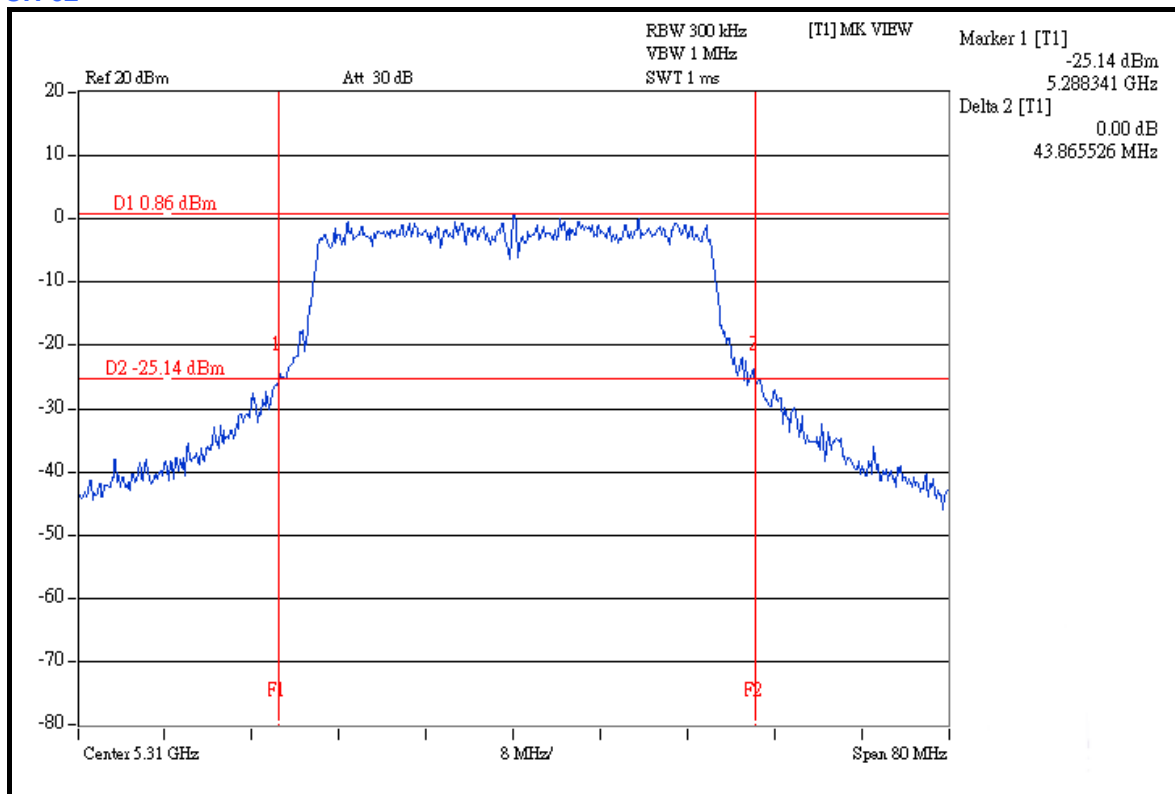

CH 102

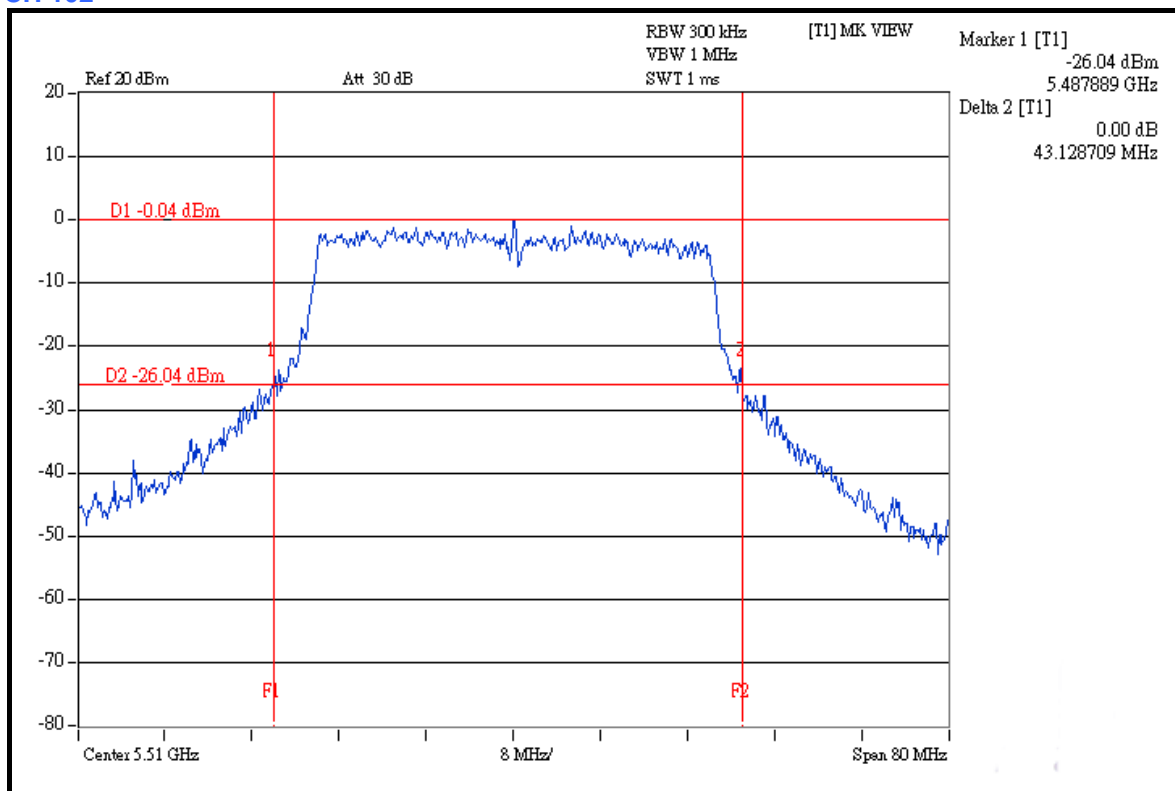



A D T

CH 118

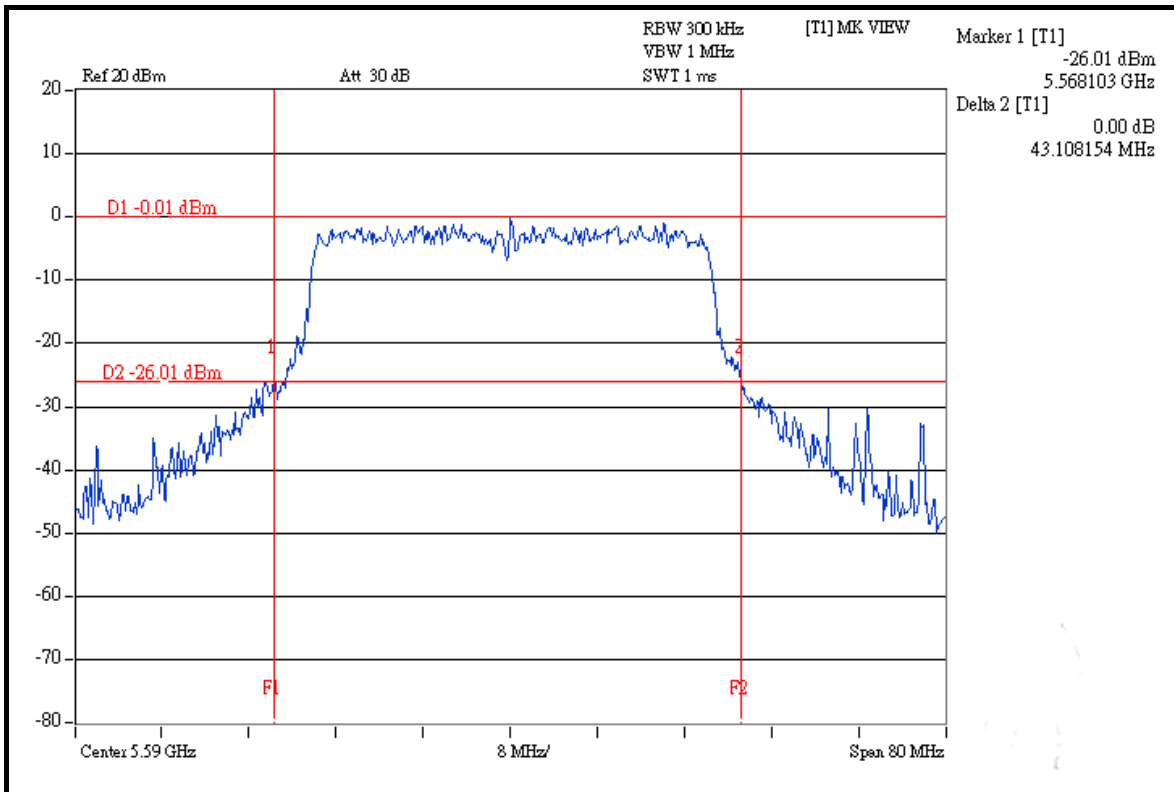

CH 134

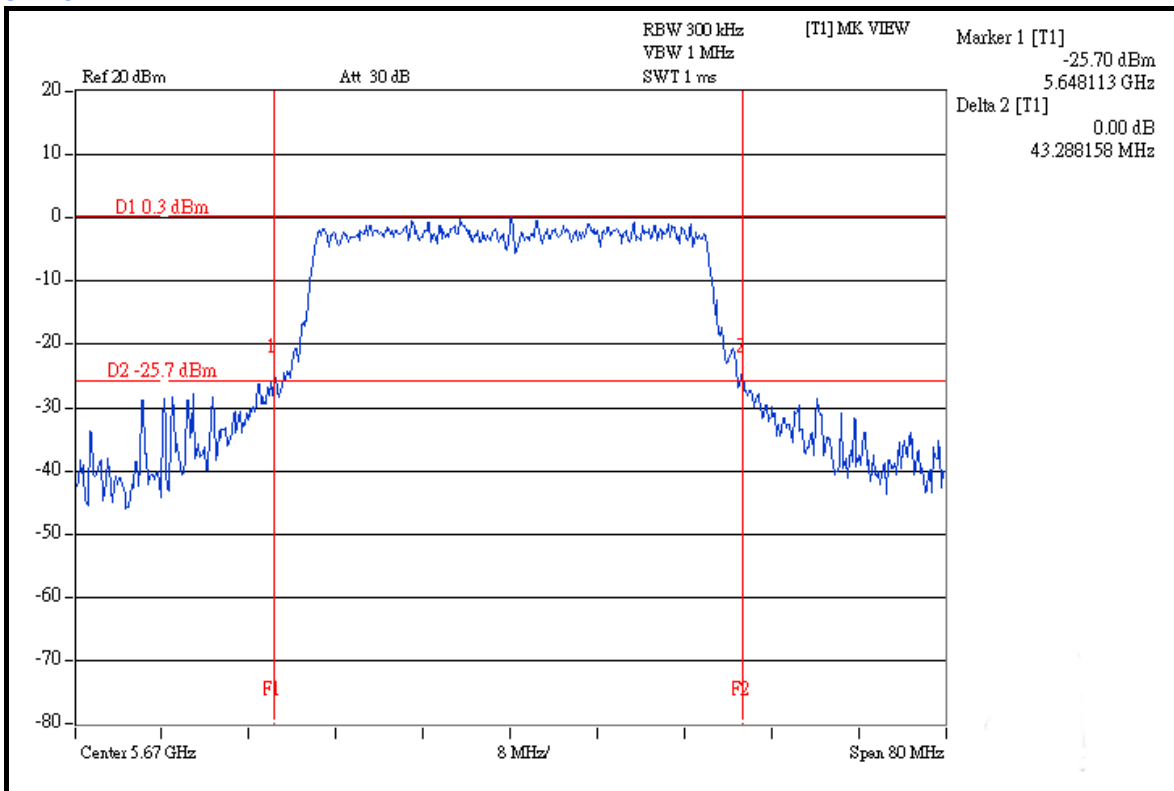

4.4 PEAK POWER EXCURSION MEASUREMENT

4.4.1 LIMITS OF PEAK POWER EXCURSION MEASUREMENT

FREQUENCY BAND	LIMIT
5.250 ~ 5.350GHz	13dB
5.470 ~ 5.725GHz	13dB

4.4.2 TEST INSTRUMENTS

DESCRIPTION & MANUFACTURER	MODEL NO.	SERIAL NO.	DATE OF CALIBRATION	DUE DATE OF CALIBRATION
R&S SPECTRUM ANALYZER	FSP40	100040	Jun. 29, 2007	Jun. 28, 2008

NOTE: The calibration interval of the above test instruments is 12 months and the calibrations are traceable to NML/ROC and NIST/USA.

4.4.3 TEST PROCEDURE

- a. The transmitter output was connected to the spectrum analyzer.
- b. Set the spectrum bandwidth span to view the entire spectrum.
- c. Using peak detector and Max-hold function for Trace 1 (RB = 1MHz, VB = 3MHz) and 2 (RB = 1MHz, VB = 300kHz).
- d. The largest difference between Trace 1 and Trace 2 in any 1MHz band on any frequency was recorded.

4.4.4 DEVIATION FROM TEST STANDARD

No deviation

4.4.5 TEST SETUP



4.4.6 EUT OPERATING CONDITIONS

The software provided by client to enable the EUT under transmission condition continuously at specific channel frequencies individually.

4.4.7 TEST RESULTS

802.11a OFDM MODULATION

MODULATION TYPE	BPSK	TRANSFER RATE	6.0Mbps
INPUT POWER (SYSTEM)	120Vac, 60Hz	ENVIRONMENTAL CONDITIONS	25 deg.C, 65 %RH, 991hPa
TESTED BY	Brad Wu		

CHANNEL	CHANNEL FREQUENCY (MHz)	PEAK POWER EXCURSION (dB)	PEAK TO AVERAGE EXCURSION LIMIT (dB)	PASS / FAIL
52	5260	8.36	13	PASS
60	5300	8.84	13	PASS
64	5320	7.47	13	PASS
100	5500	8.31	13	PASS
120	5600	8.07	13	PASS
140	5700	8.40	13	PASS



A D T

CH 52

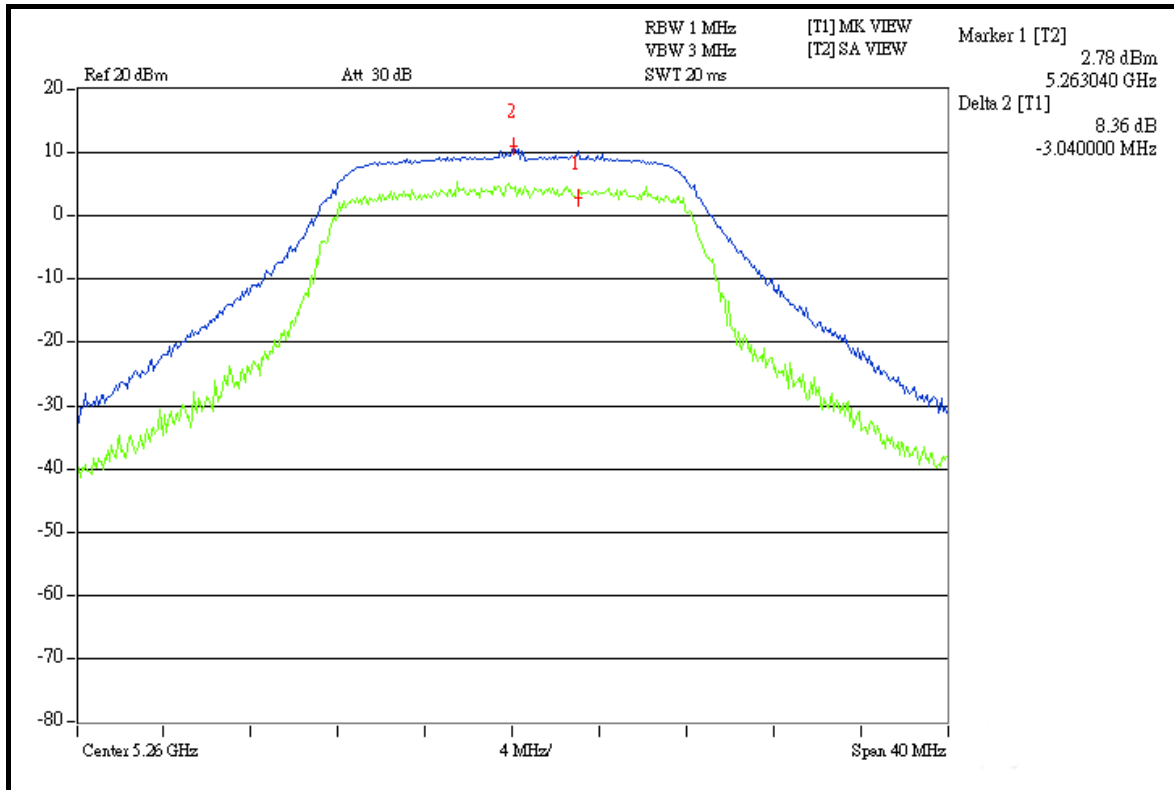

CH 60

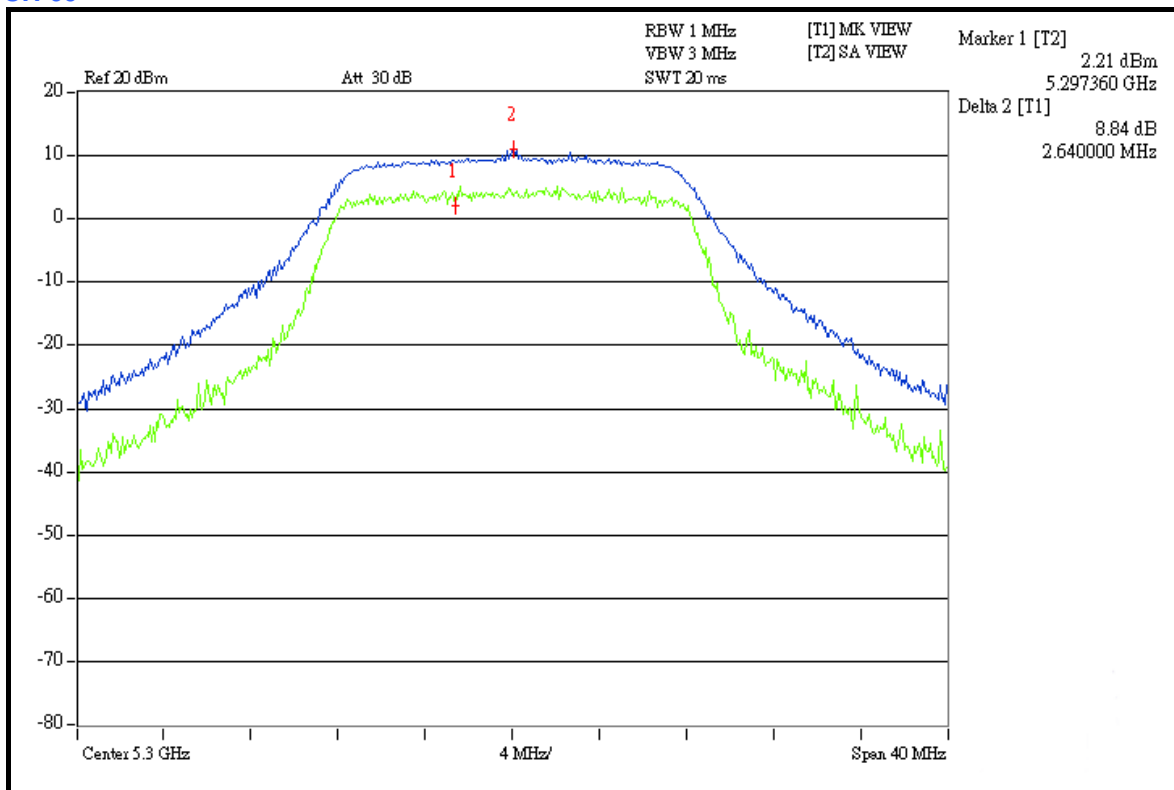



A D T

CH 64

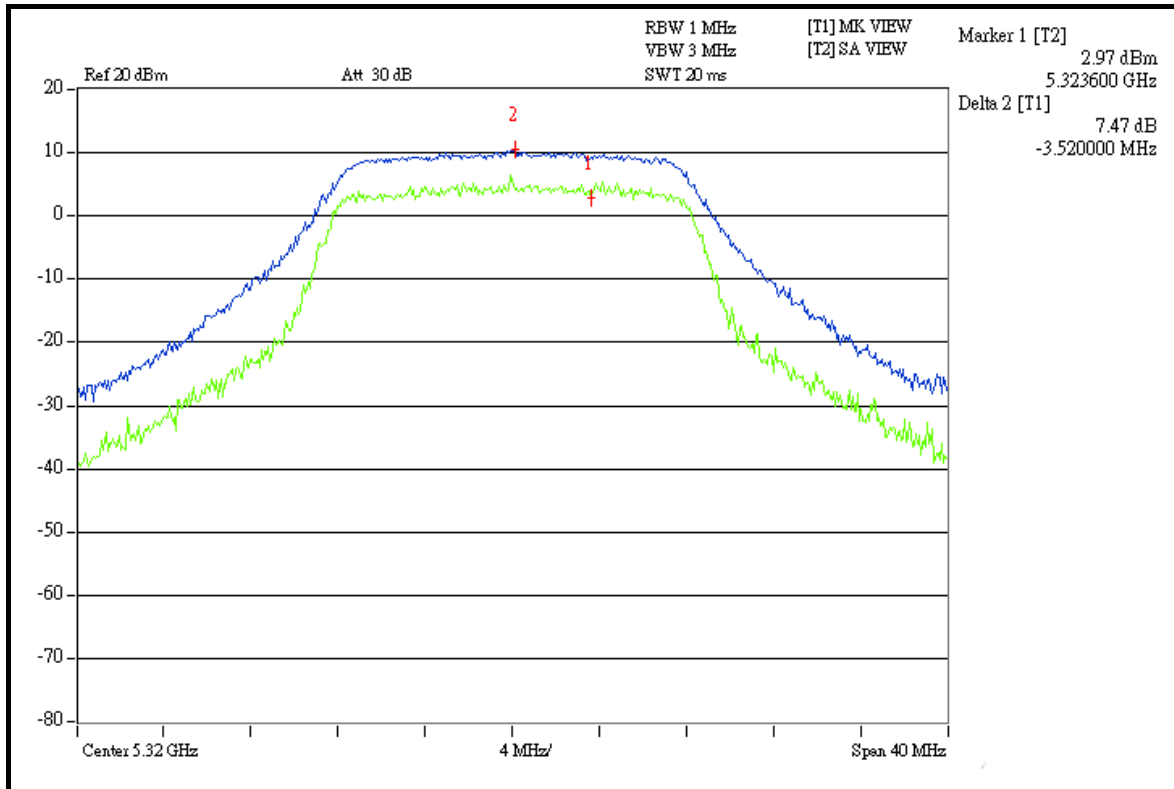

CH 100

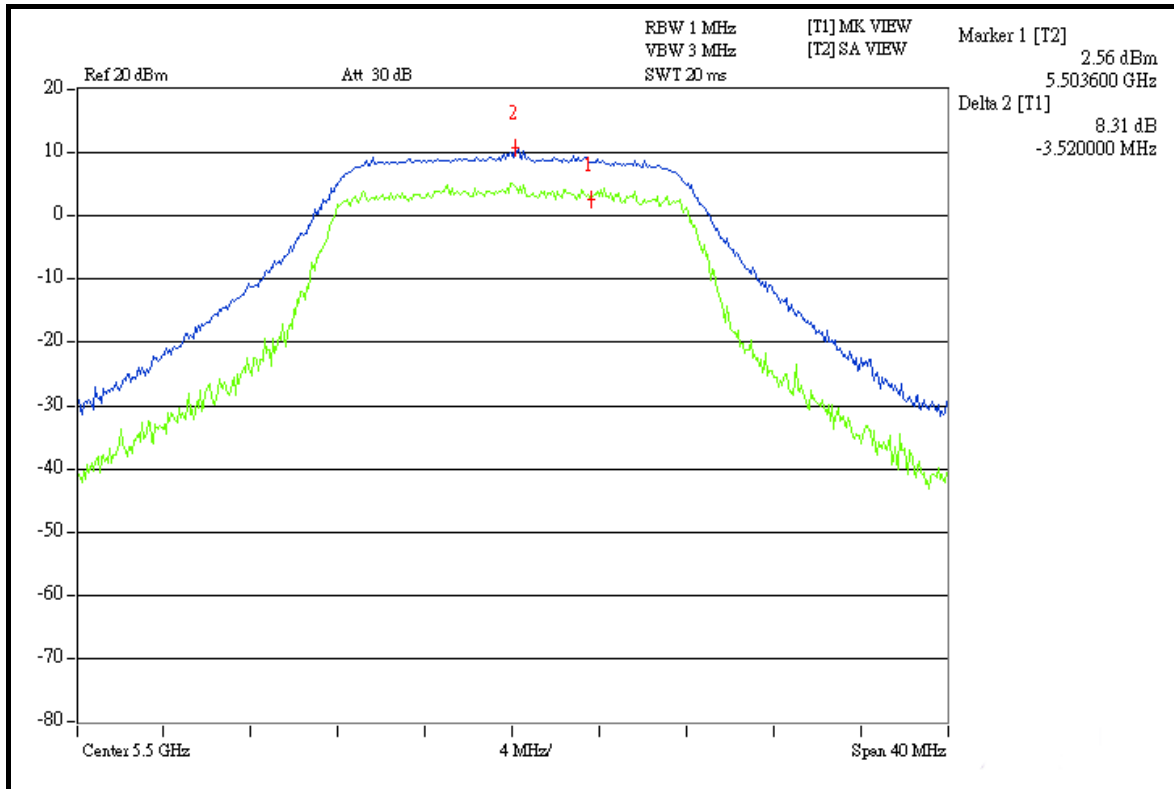



A D T

CH 120

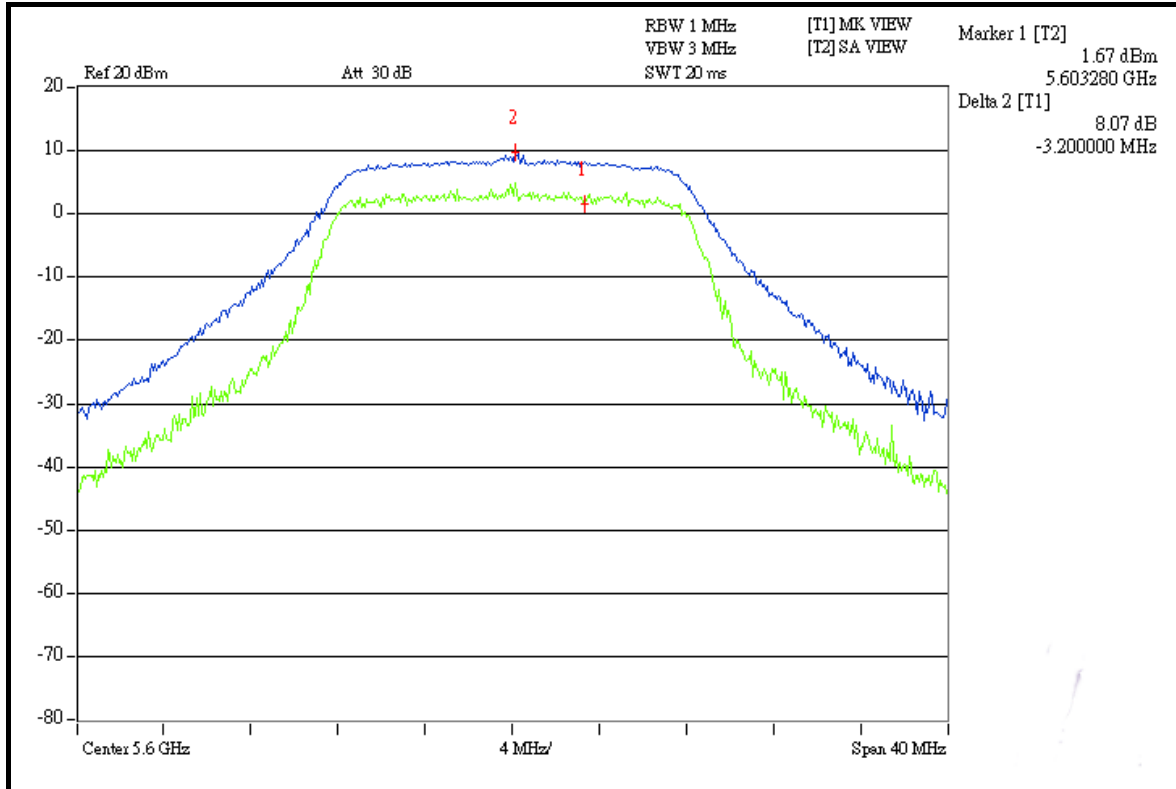

CH 140

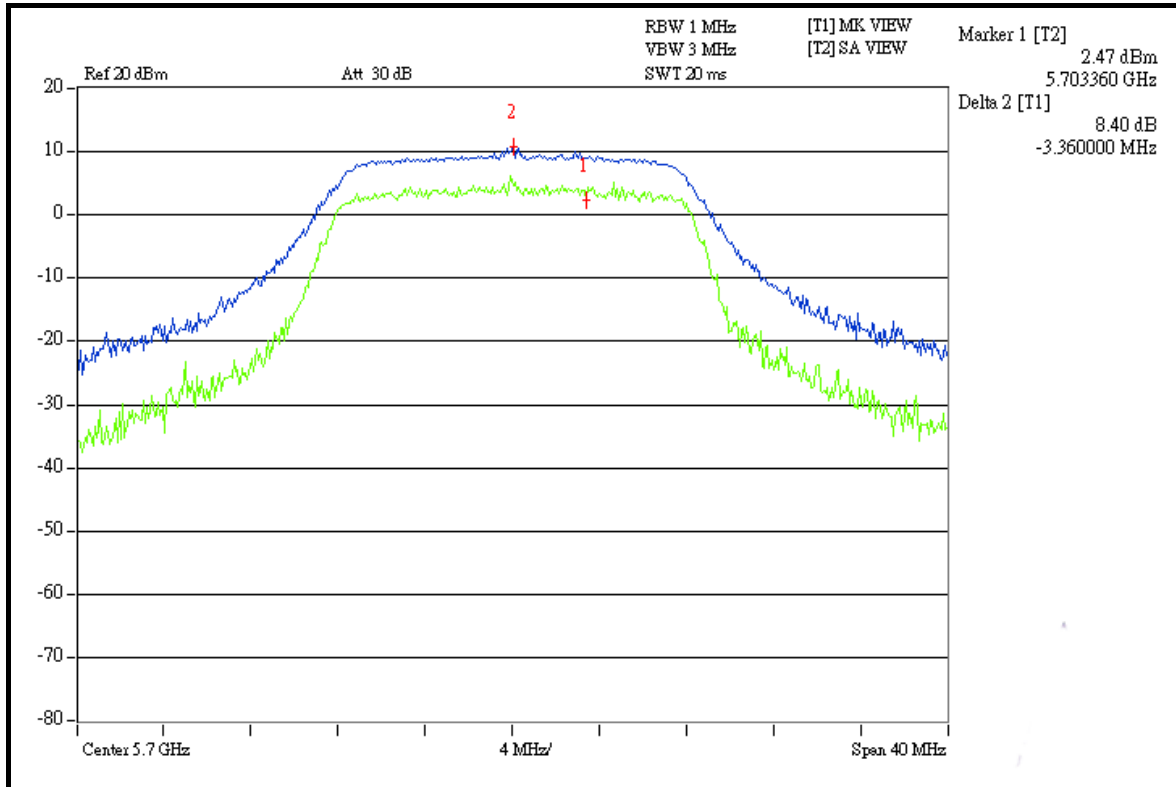



A D T

DRAFT 802.11n (20MHz) OFDM MODULATION

MODULATION TYPE	BPSK	TRANSFER RATE	7.2Mbps
INPUT POWER (SYSTEM)	120Vac, 60Hz	ENVIRONMENTAL CONDITIONS	25 deg.C, 65 %RH, 991hPa
TESTED BY	Brad Wu		

CHANNEL	CHANNEL FREQUENCY (MHz)	PEAK POWER EXCURSION (dB)		PEAK to AVERAGE EXCURSION LIMIT (dB)	PASS/FAIL
		CHAIN 0	CHAIN 1		
52	5260	9.06	7.57	13	PASS
60	5300	8.17	8.43	13	PASS
64	5320	7.83	7.91	13	PASS
100	5500	9.01	8.40	13	PASS
120	5600	7.49	8.63	13	PASS
140	5700	8.60	8.73	13	PASS



A D T

CHAIN 0: CH 52

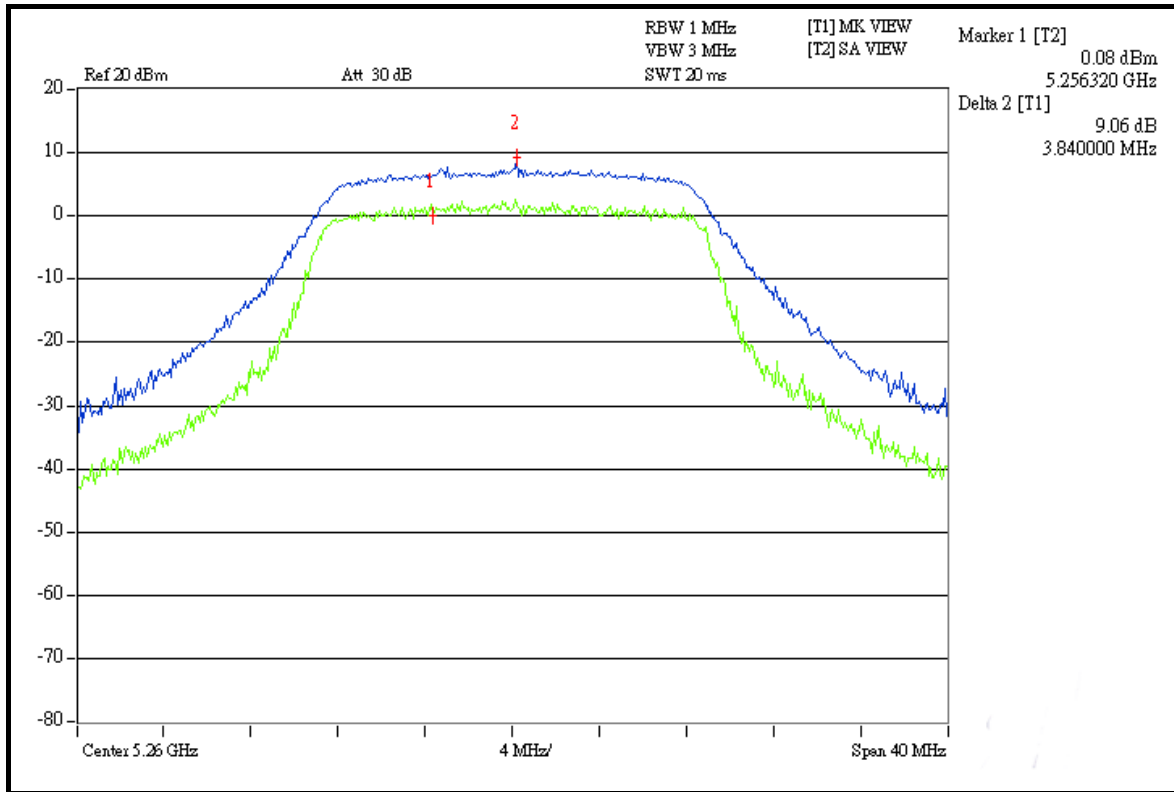

CH 60

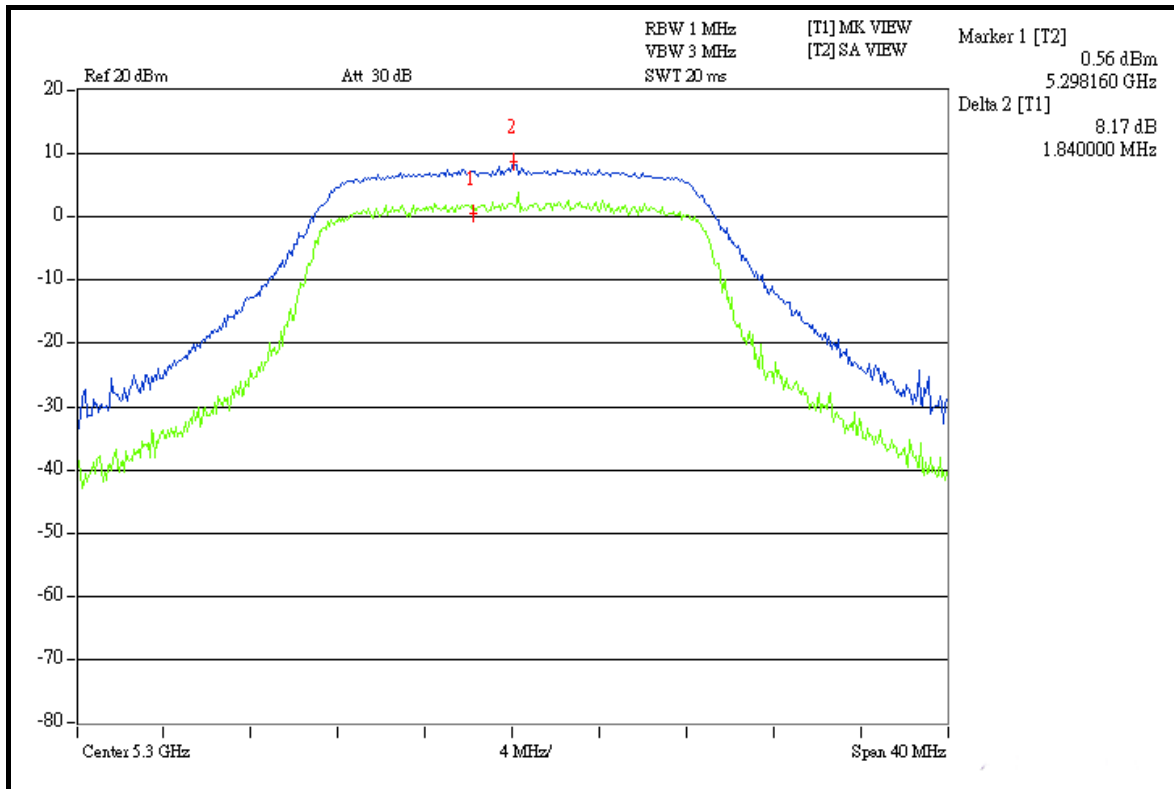



A D T

CH 64

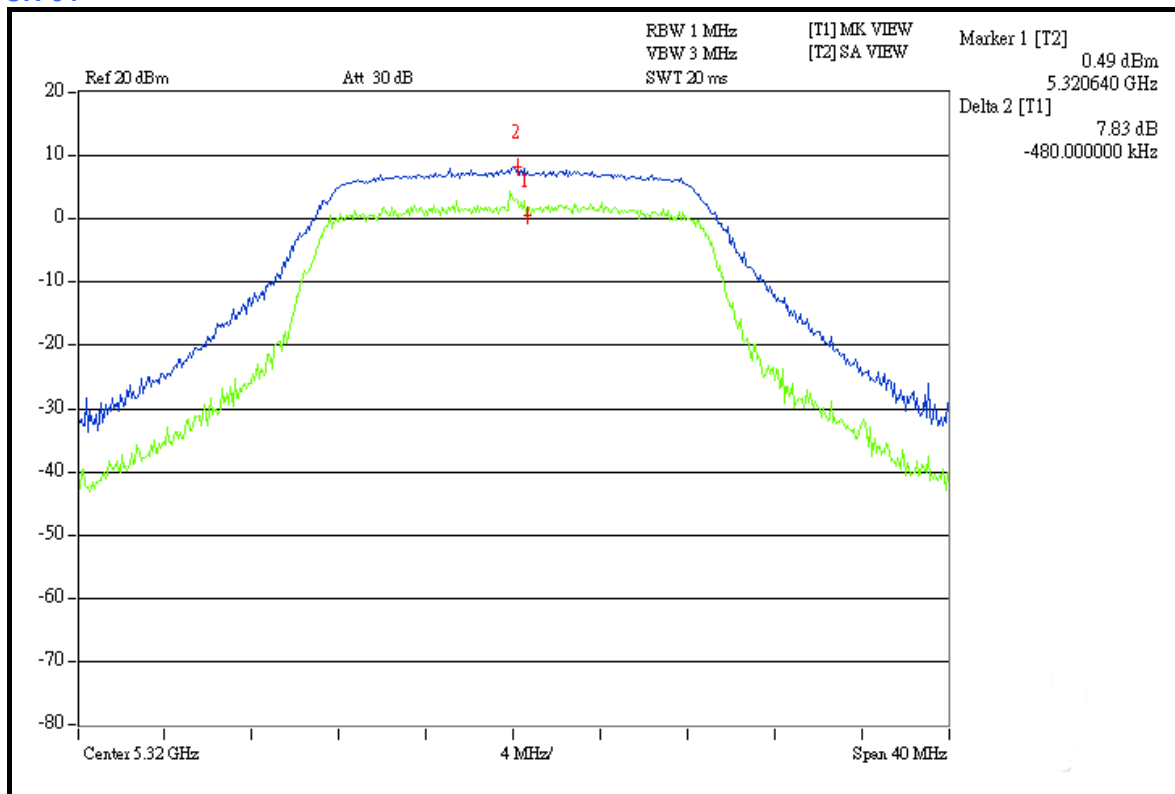

CH 100

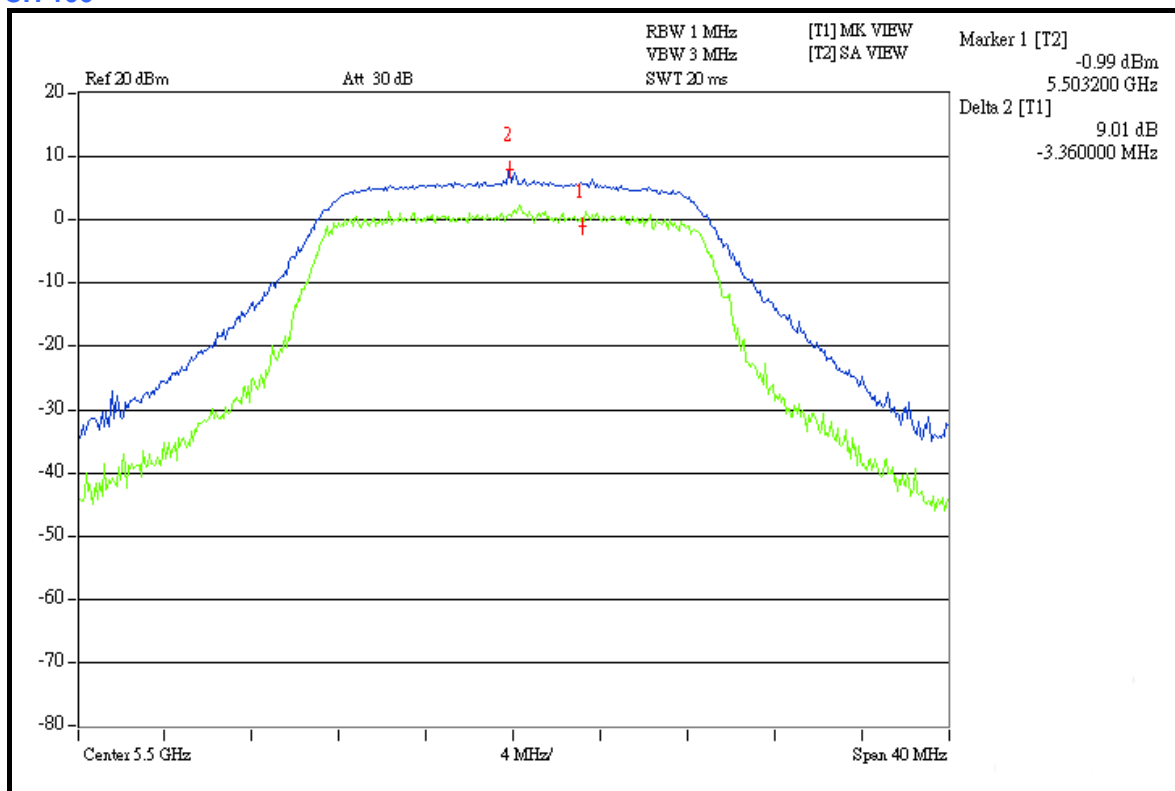



A D T

CH 120

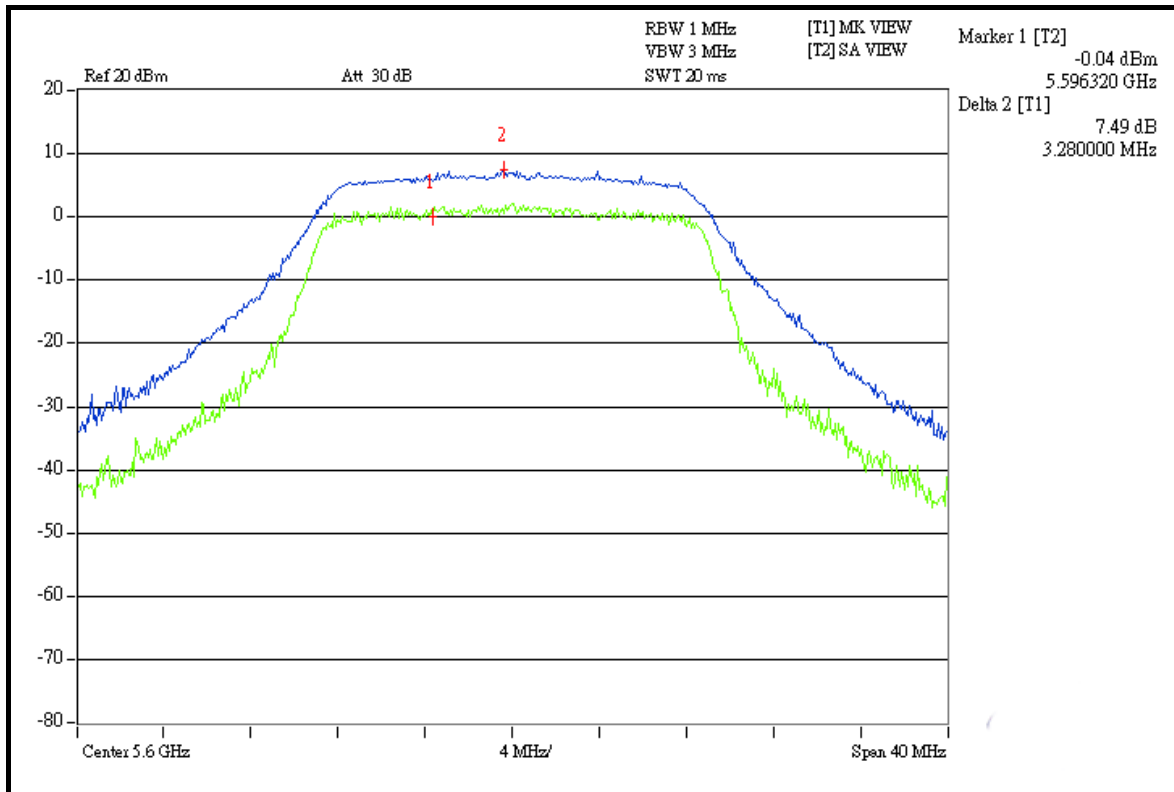

CH 140

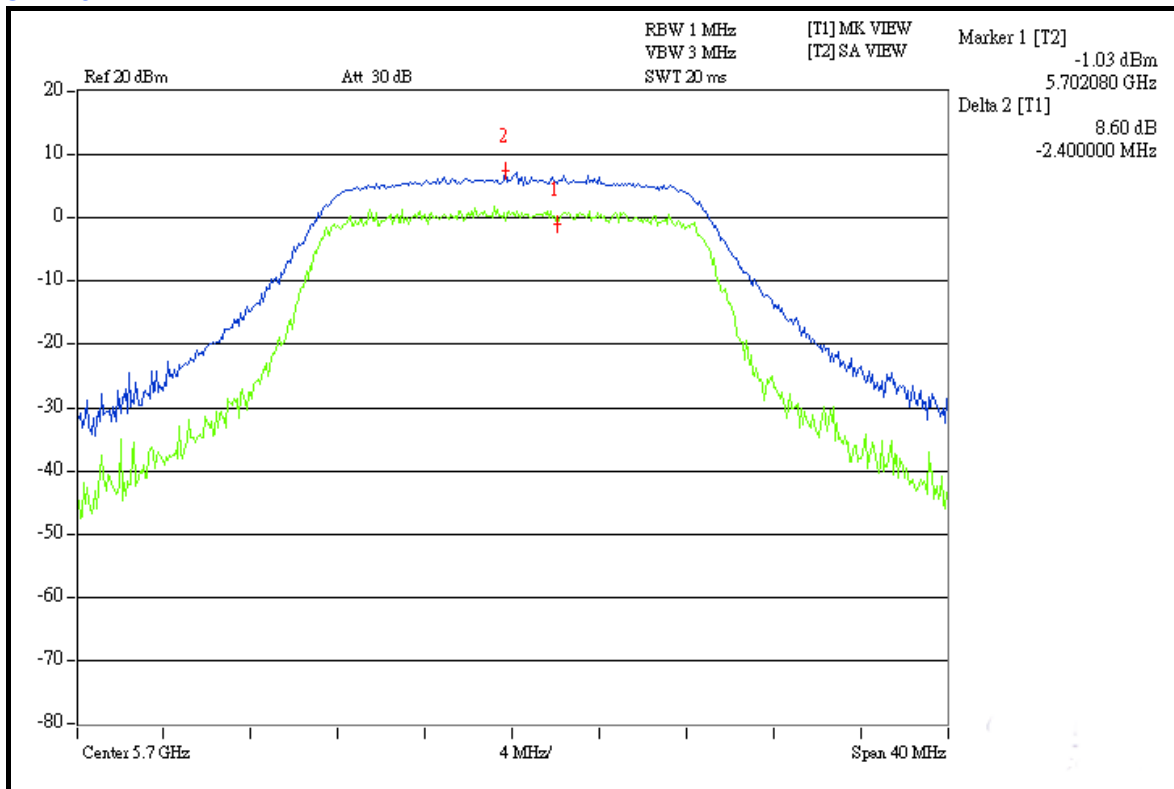



A D T

CHAIN 1: CH 52

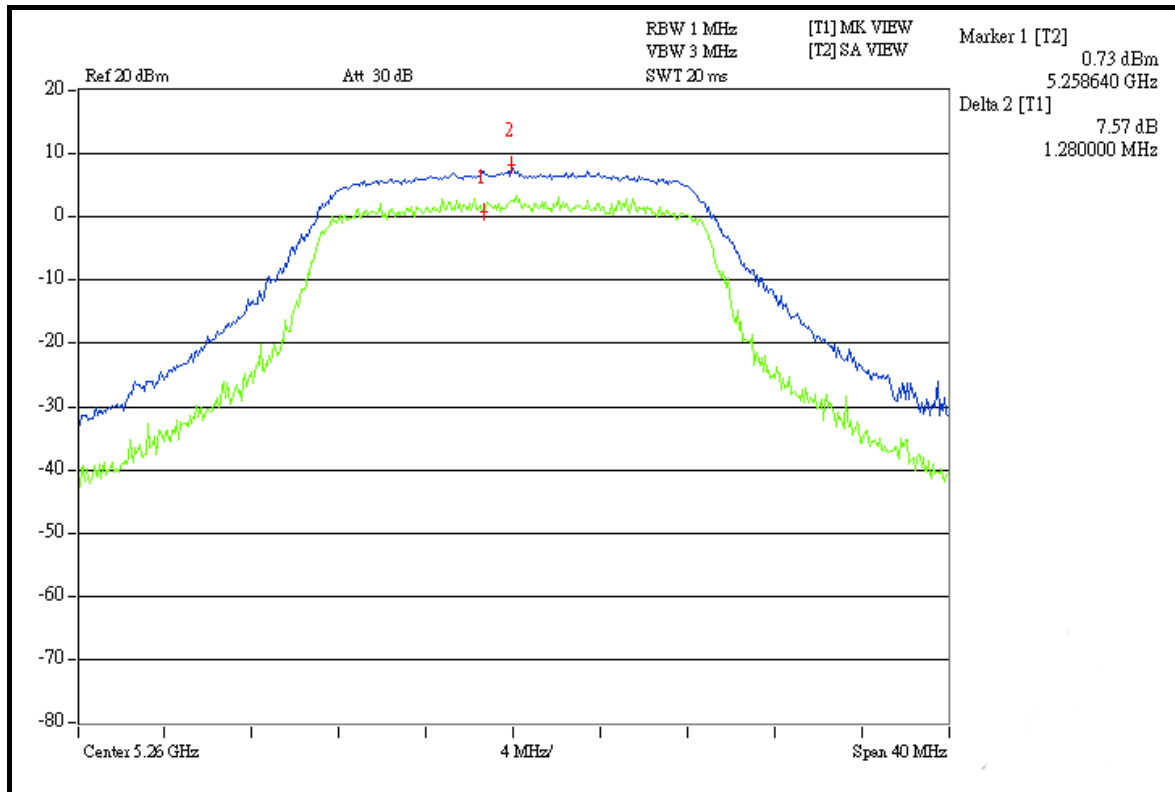

CH 60

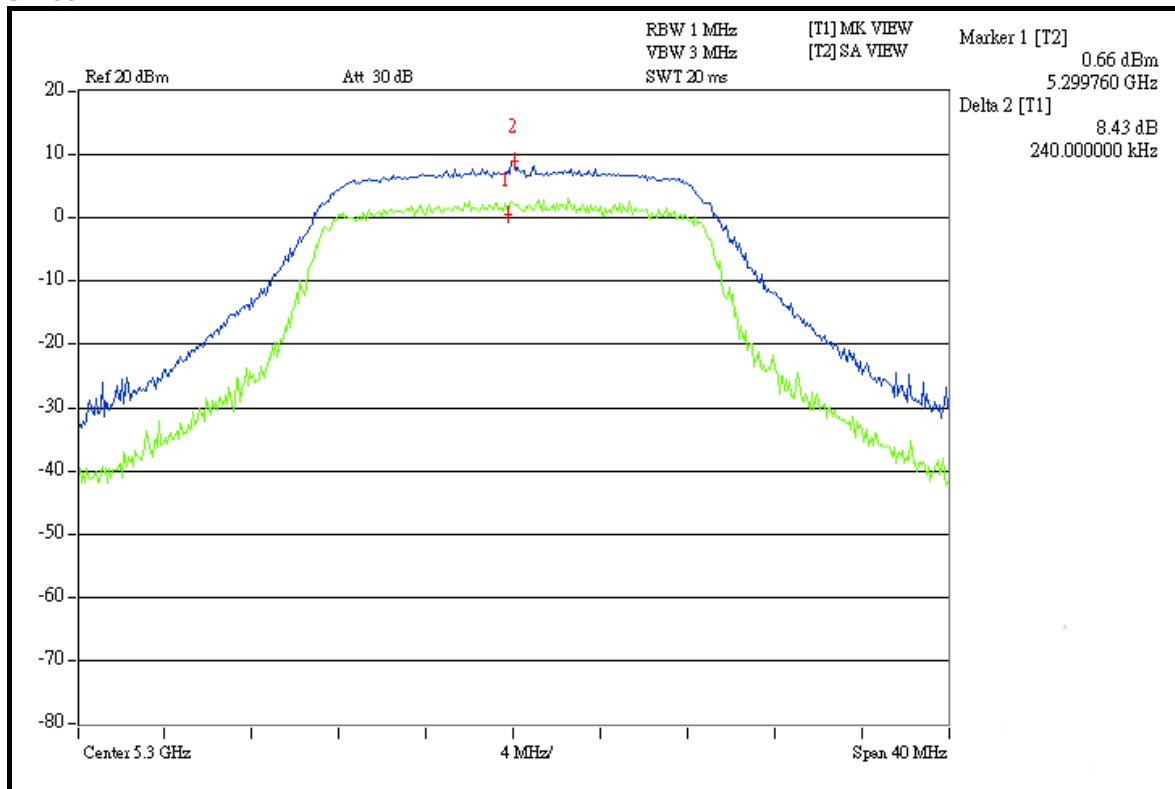



A D T

CH 64

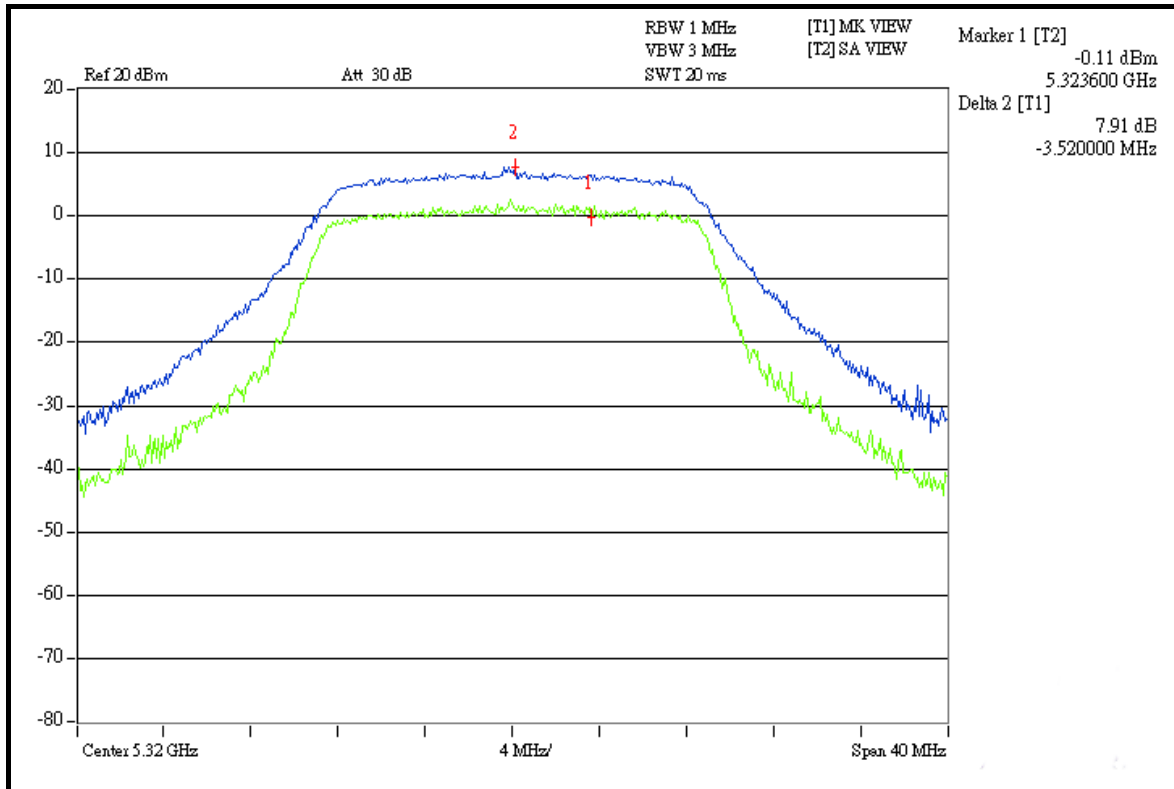

CH 100

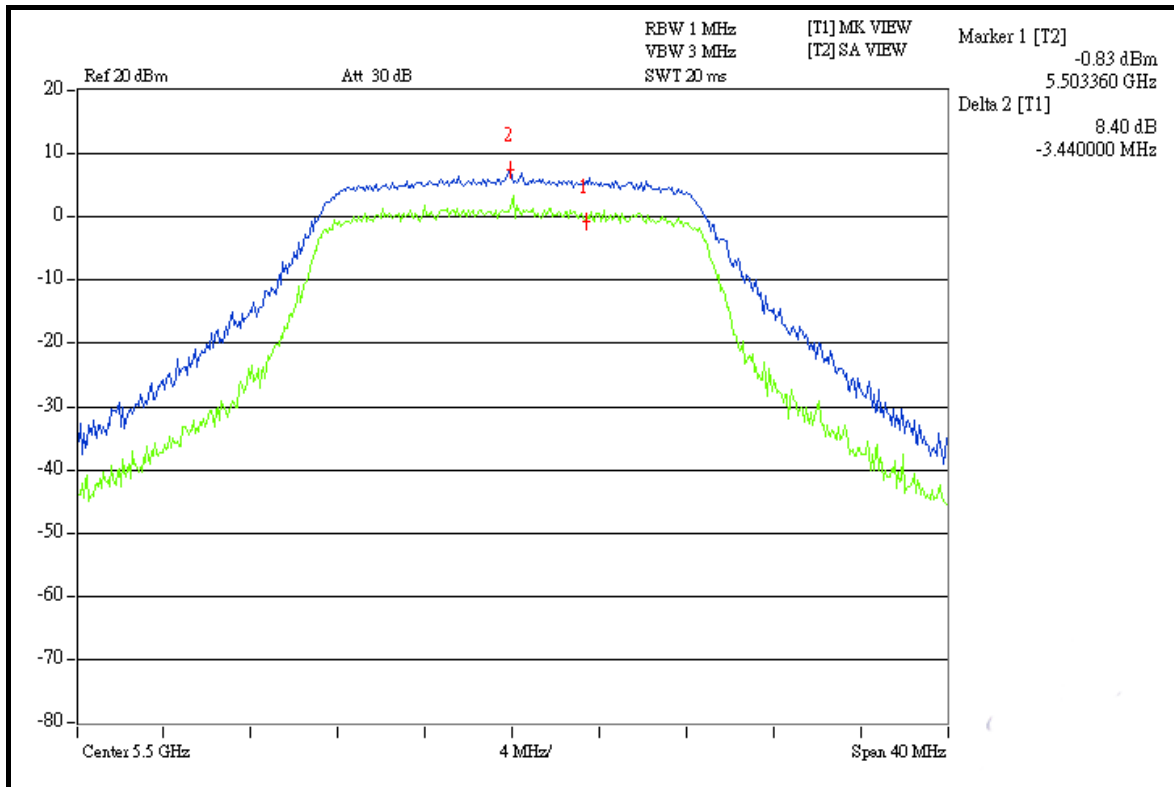



A D T

CH 120

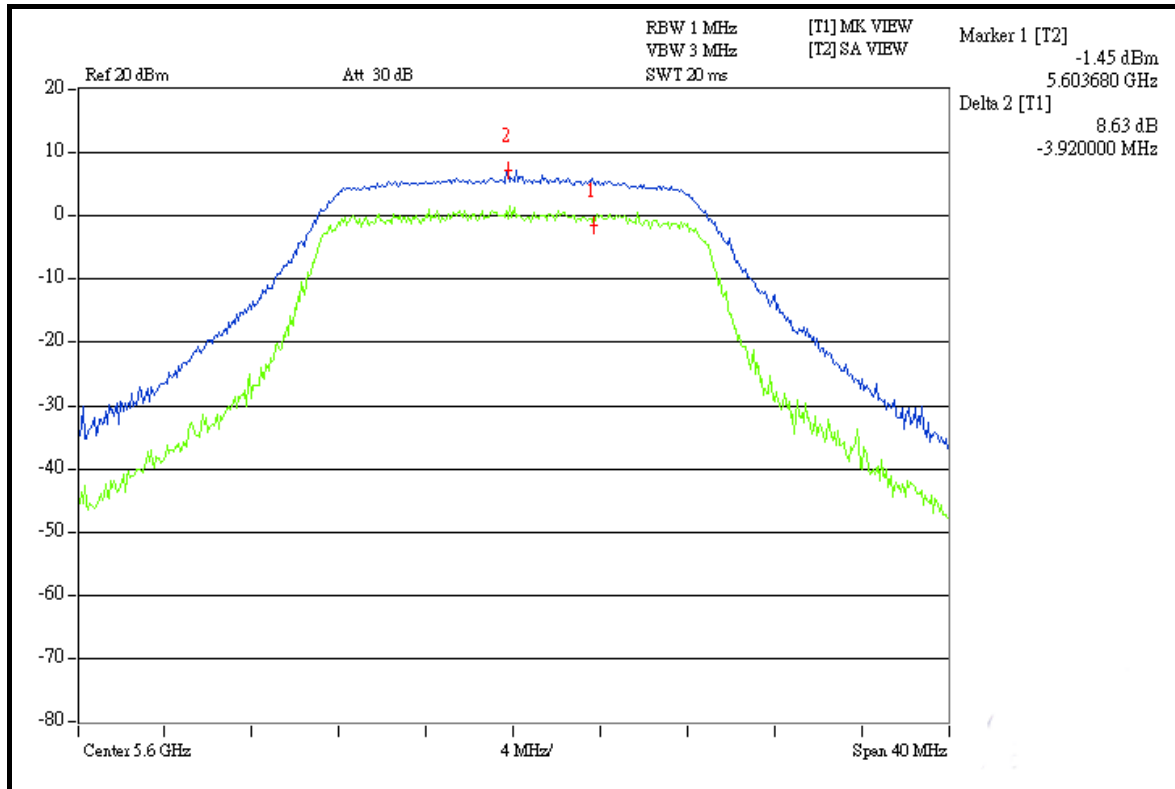

CH 140

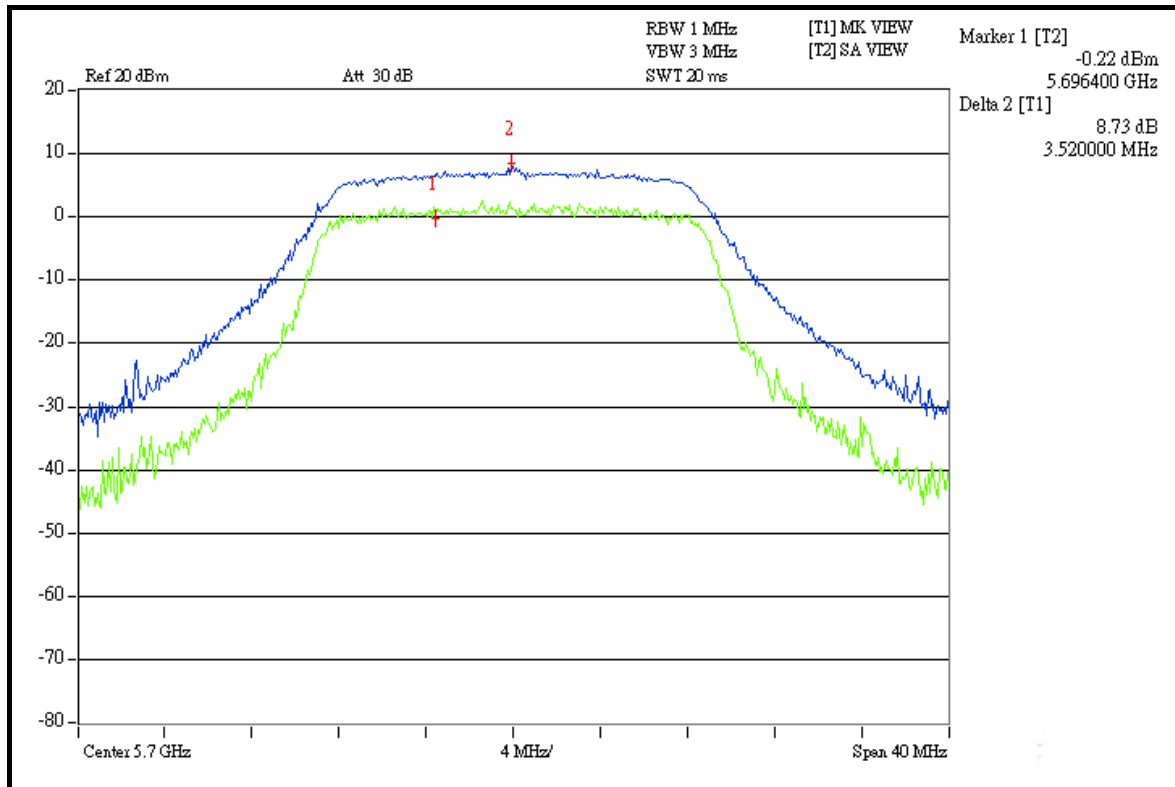



A D T

DRAFT 802.11n (40MHz) OFDM MODULATION

MODULATION TYPE	BPSK	TRANSFER RATE	15.0Mbps
INPUT POWER (SYSTEM)	120Vac, 60Hz	ENVIRONMENTAL CONDITIONS	25 deg.C, 65 %RH, 991hPa
TESTED BY	Brad Wu		

CHANNEL	CHANNEL FREQUENCY (MHz)	PEAK POWER EXCURSION (dB)		PEAK to AVERAGE EXCURSION LIMIT (dB)	PASS/FAIL
		CHAIN 0	CHAIN 1		
54	5270	8.56	7.90	13	PASS
62	5310	8.51	8.41	13	PASS
102	5510	7.68	7.61	13	PASS
118	5590	7.71	8.18	13	PASS
134	5670	8.33	8.50	13	PASS



A D T

CHAIN 0: CH 54

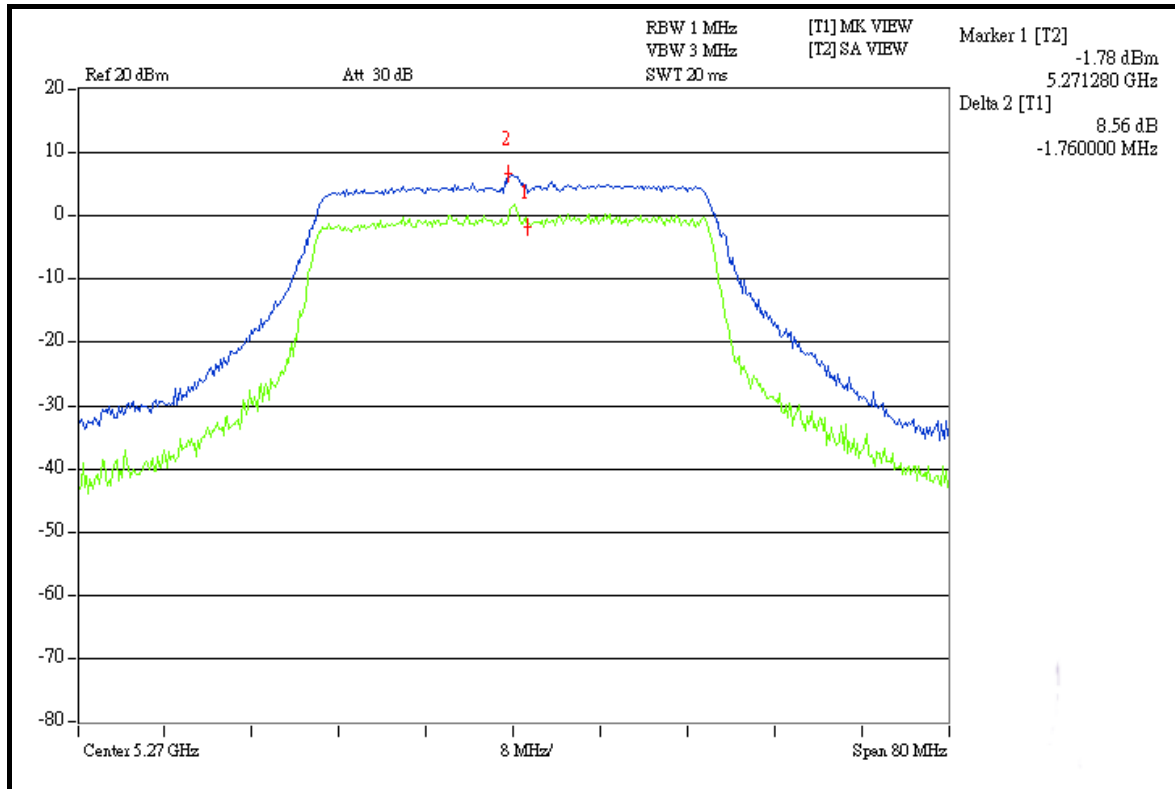

CH 62

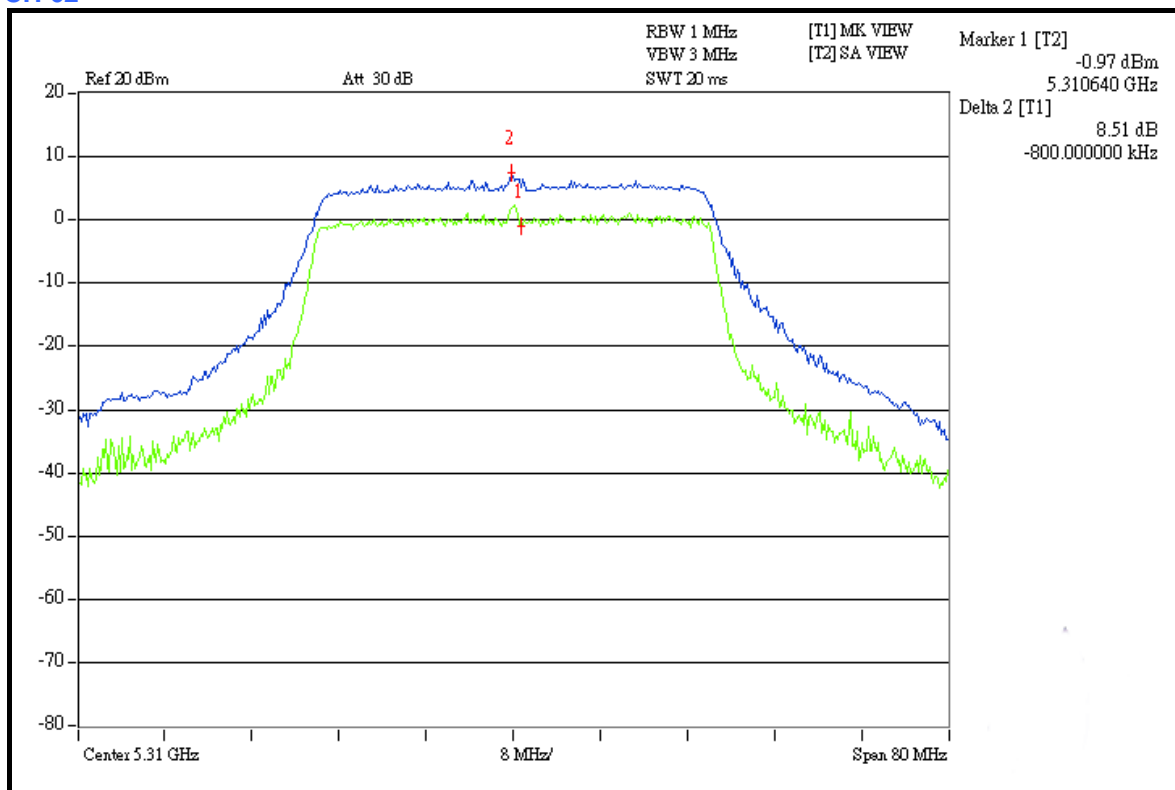



A D T

CH 102

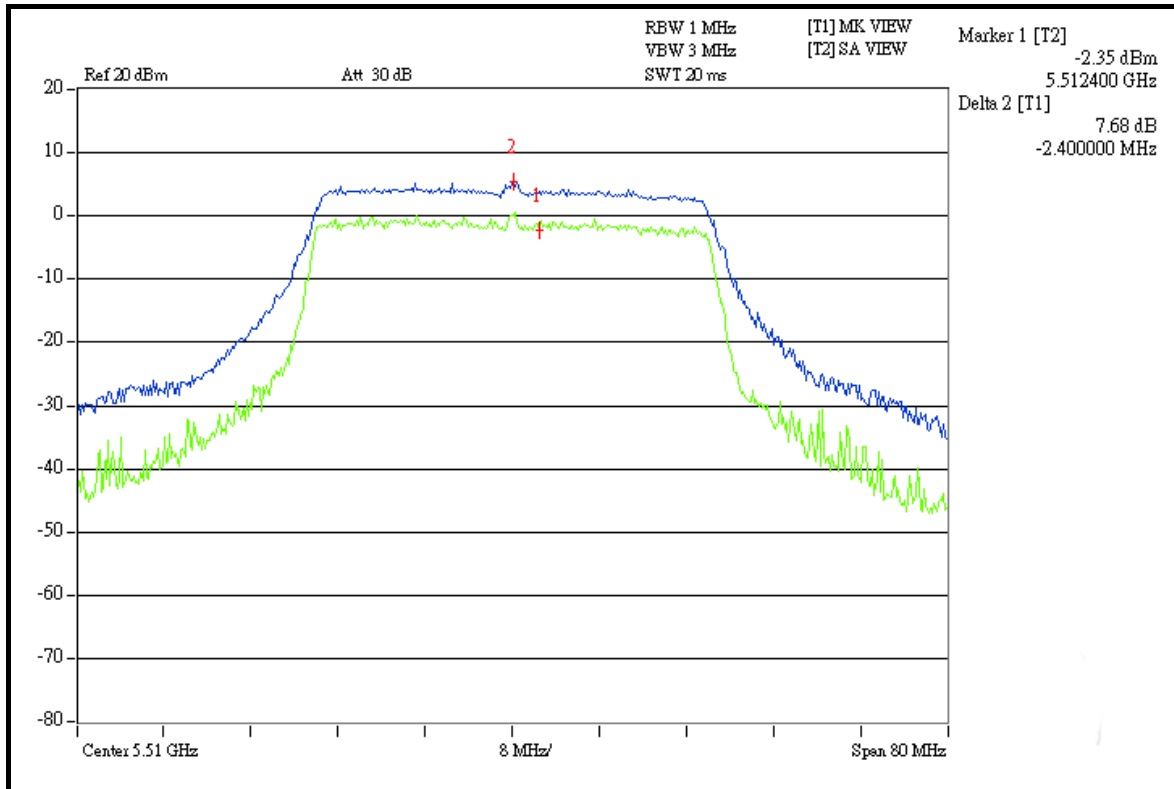

CH 118

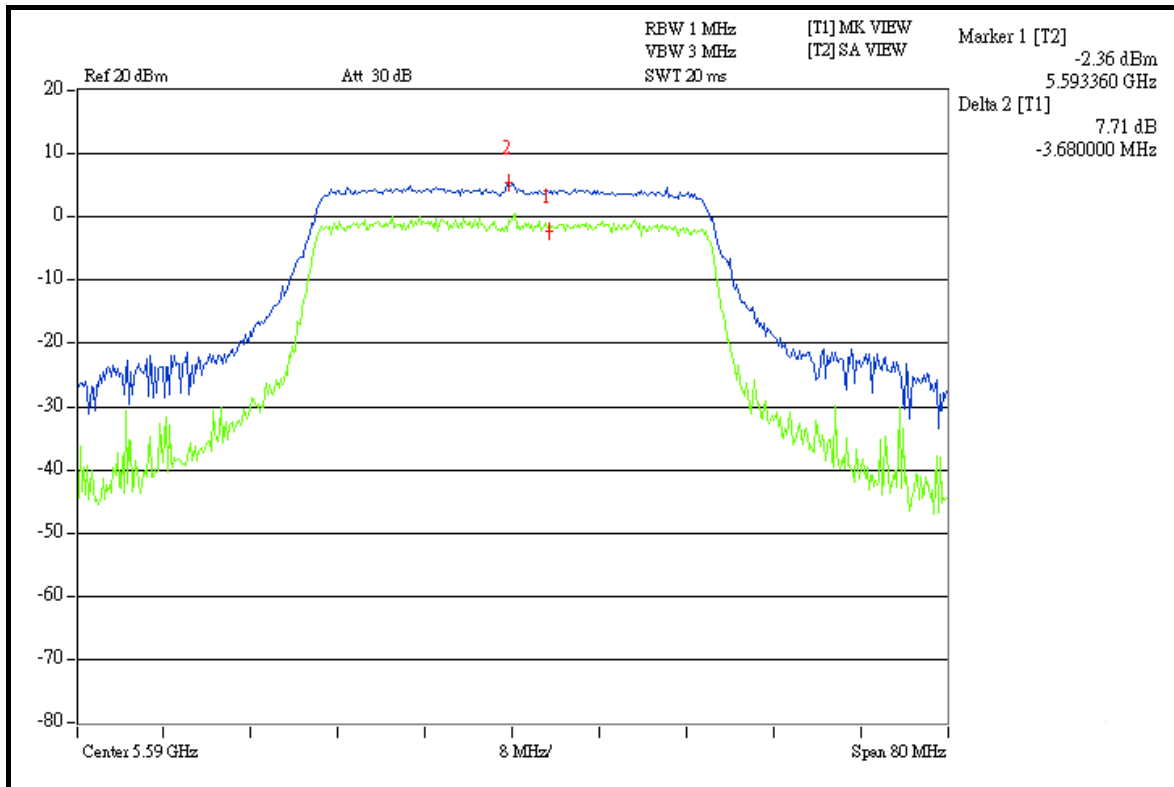



A D T

CH 134

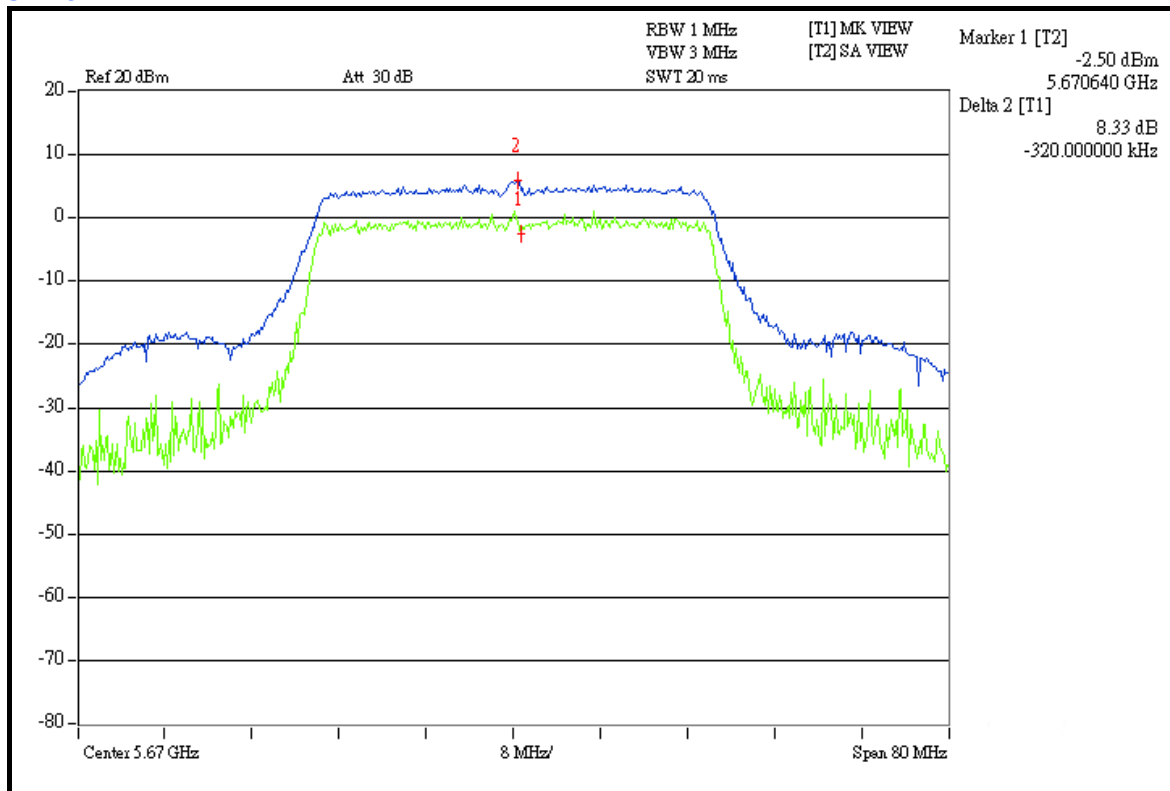

CHAIN 1: CH 54

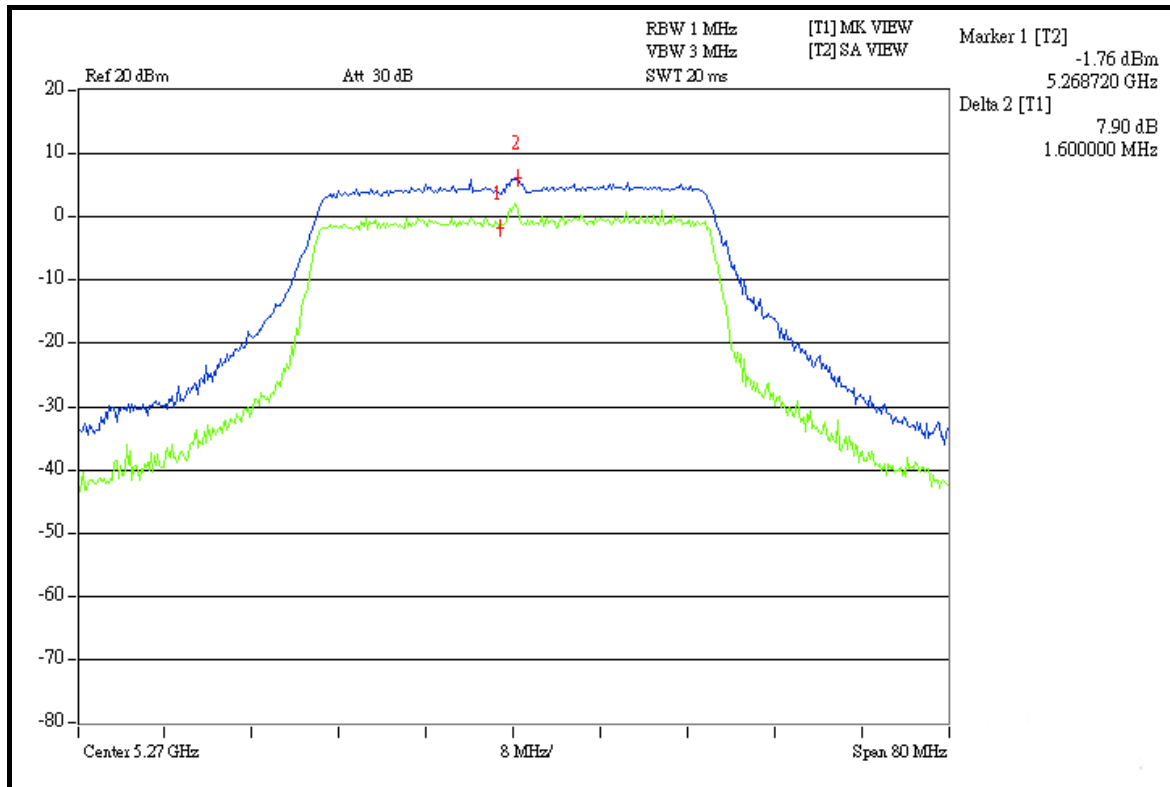



A D T

CH 62

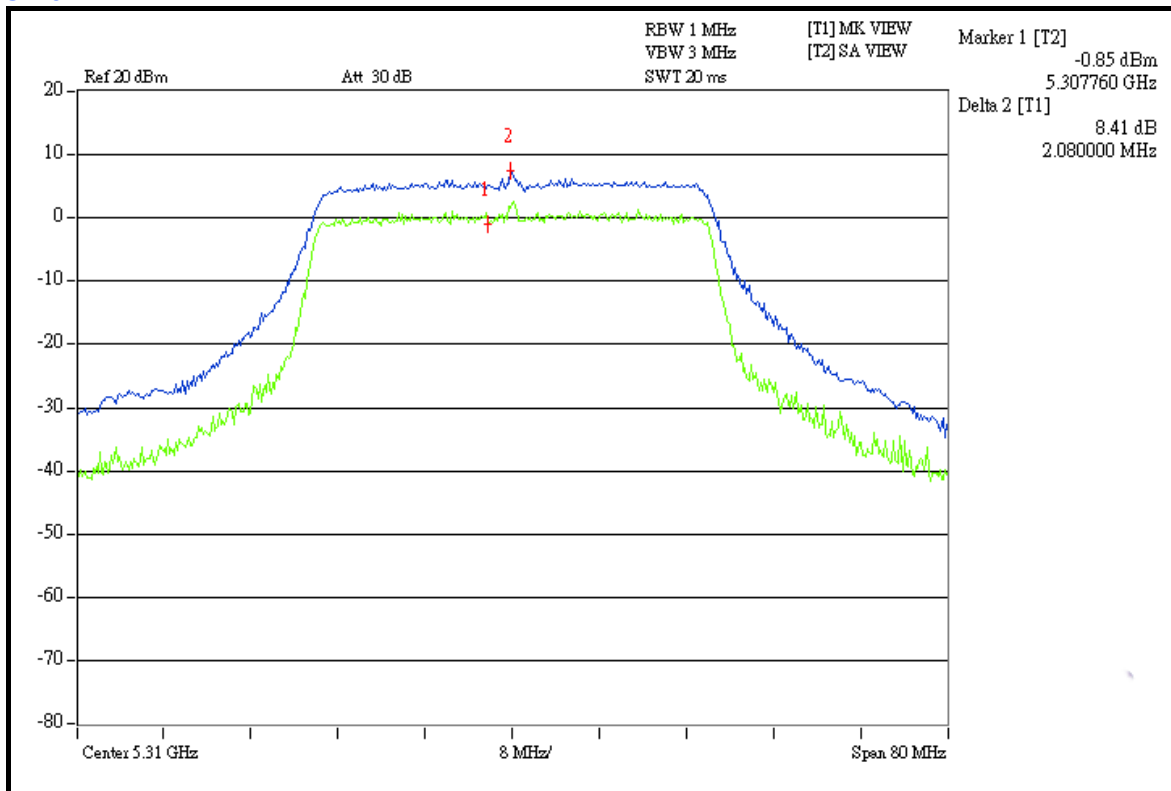

CH 102

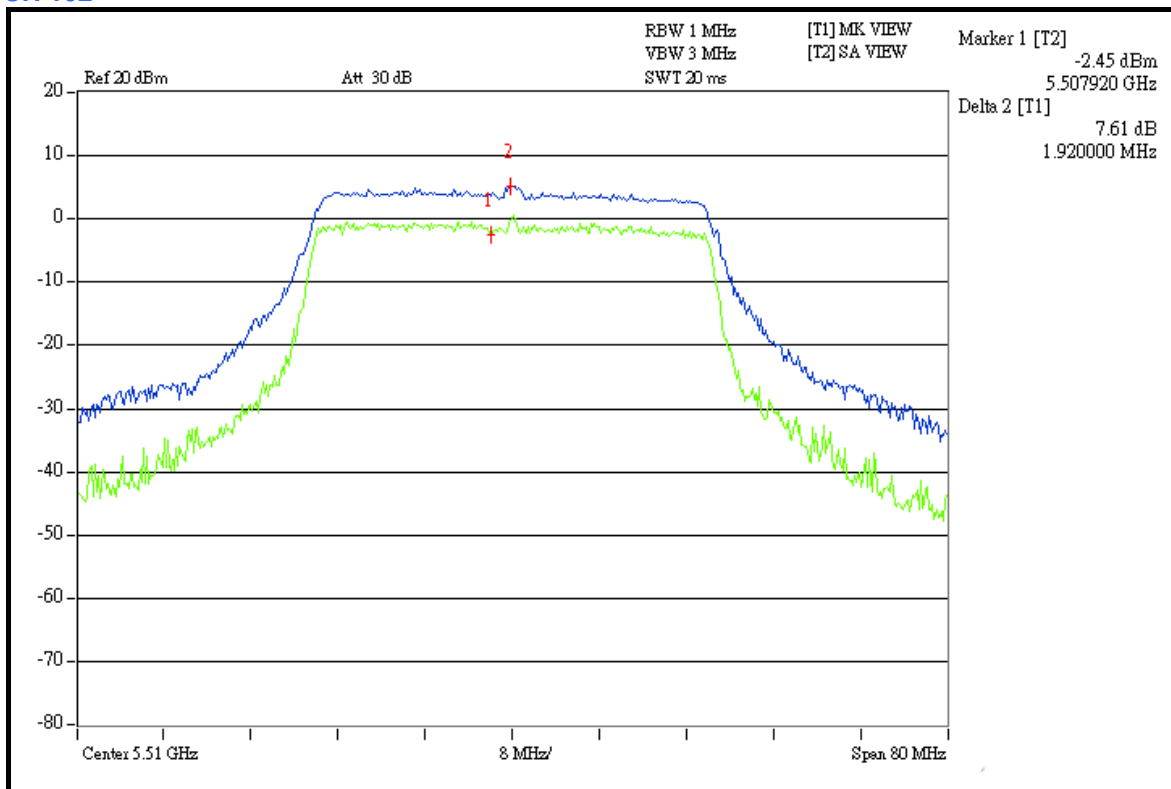



A D T

CH 118

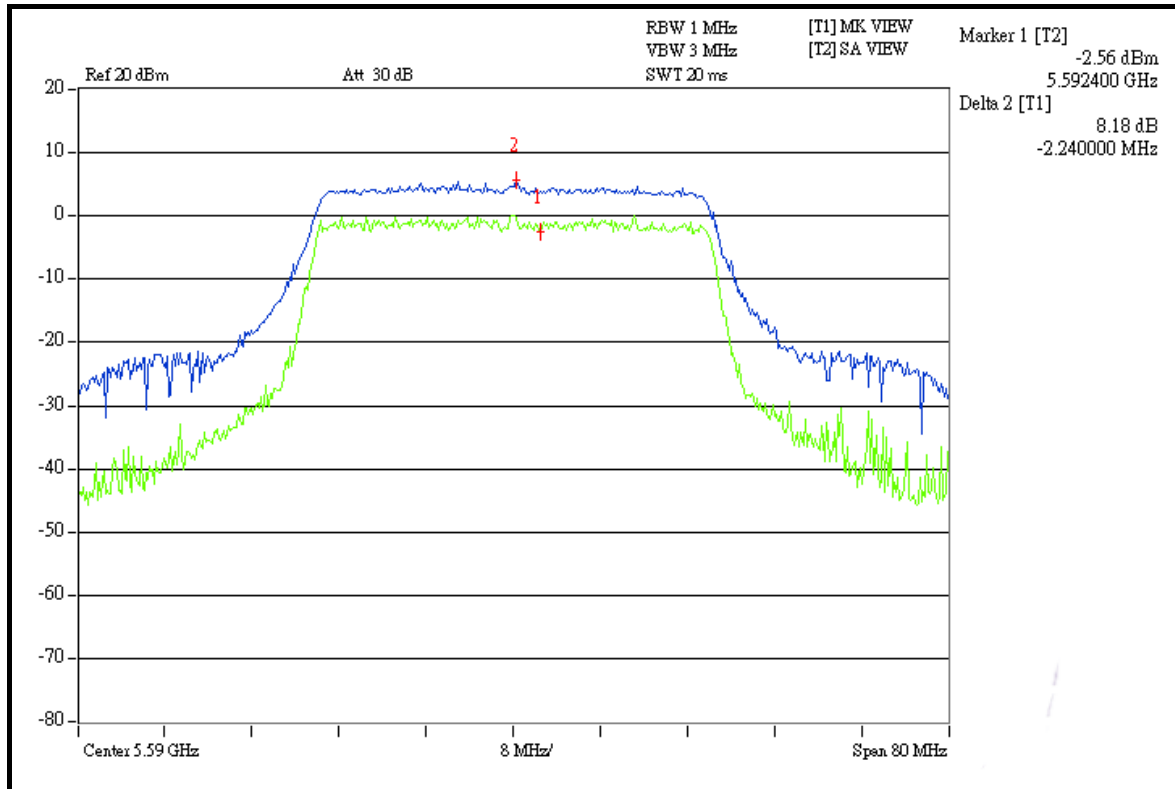

CH 134

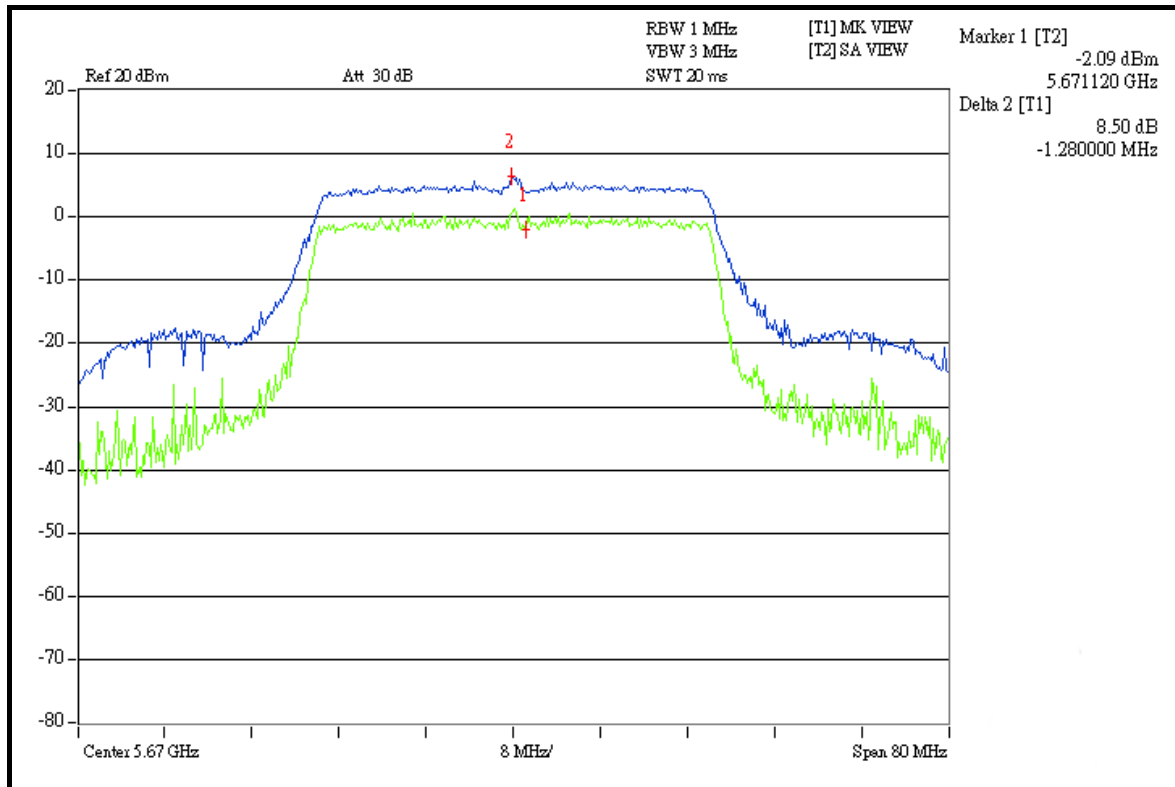

4.5 PEAK POWER SPECTRAL DENSITY MEASUREMENT

4.5.1 LIMITS OF PEAK POWER SPECTRAL DENSITY MEASUREMENT

FREQUENCY BAND	LIMIT
5.250 ~ 5.350GHz	11dBm
5.470 ~ 5.725GHz	11dBm

4.5.2 TEST INSTRUMENTS

DESCRIPTION & MANUFACTURER	MODEL NO.	SERIAL NO.	DATE OF CALIBRATION	DUE DATE OF CALIBRATION
R&S SPECTRUM ANALYZER	FSP40	100040	Jun. 29, 2007	Jun. 28, 2008

NOTE: The calibration interval of the above test instruments is 12 months and the calibrations are traceable to NML/ROC and NIST/USA.

4.5.3 TEST PROCEDURES

- a. The transmitter output was connected to the spectrum analyzer.
- b. Set RBW = 1MHz, VBW = 3MHz. The PPSD is the highest level found across the emission in any 1MHz band.

4.5.4 DEVIATION FROM TEST STANDARD

No deviation

4.5.5 TEST SETUP

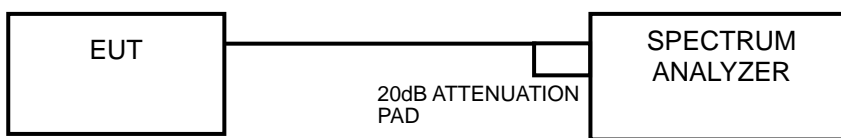

4.5.6 EUT OPERATING CONDITIONS

Same as 5.3.6

4.5.7 TEST RESULTS

802.11a OFDM MODULATION

MODULATION TYPE	BPSK	TRANSFER RATE	6.0Mbps
INPUT POWER (SYSTEM)	120Vac, 60Hz	ENVIRONMENTAL CONDITIONS	25 deg.C, 65 %RH, 991hPa
TESTED BY	Brad Wu		

CHANNEL	CHANNEL FREQUENCY (MHz)	RF POWER LEVEL IN 1MHz BW (dBm)	MAXIMUM LIMIT (dBm)	PASS / FAIL
52	5260	-0.37	11	PASS
60	5300	-0.58	11	PASS
64	5320	-0.61	11	PASS
100	5500	-0.72	11	PASS
120	5600	-0.92	11	PASS
140	5700	-0.68	11	PASS



A D T

CH 52

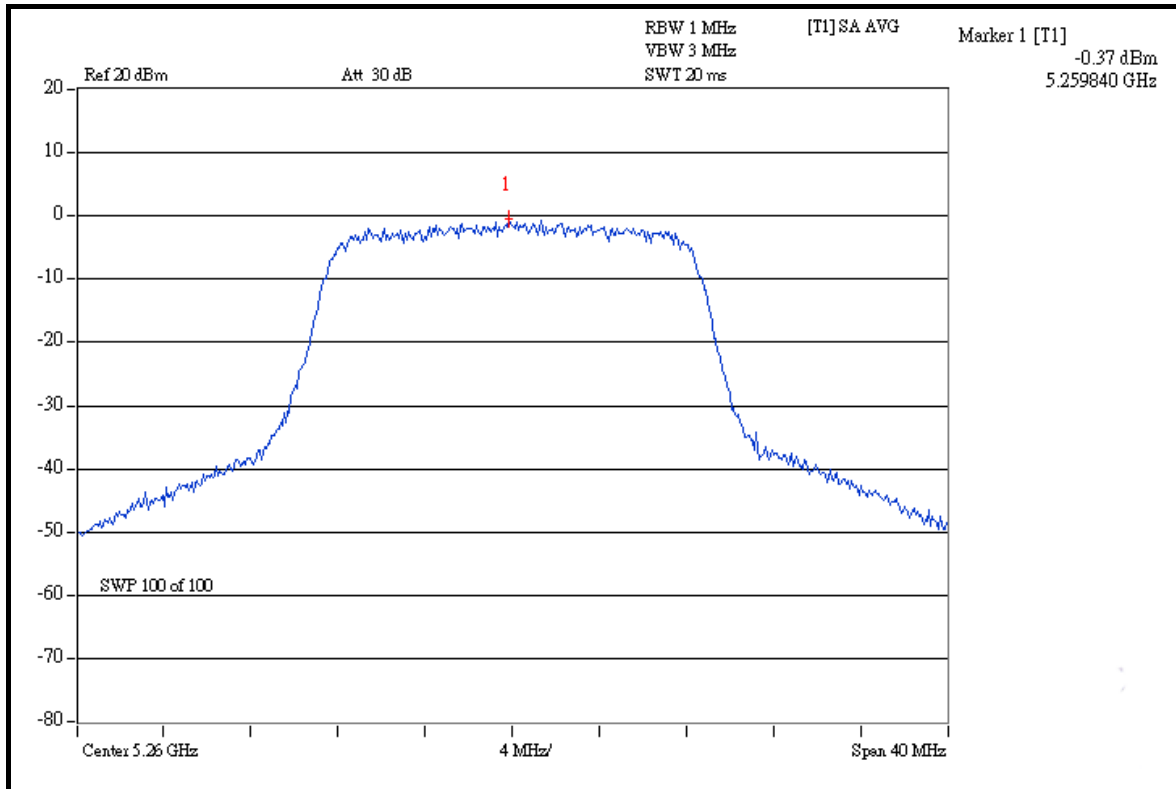

CH 60

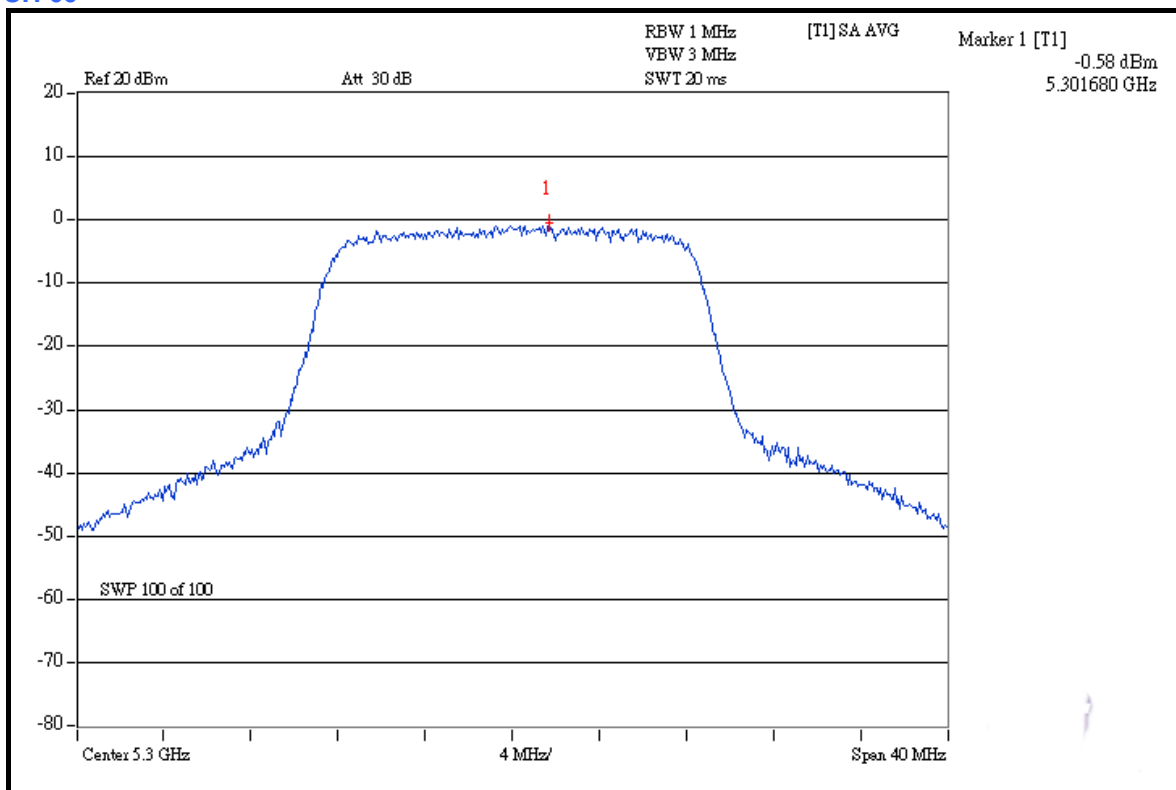



A D T

CH 64

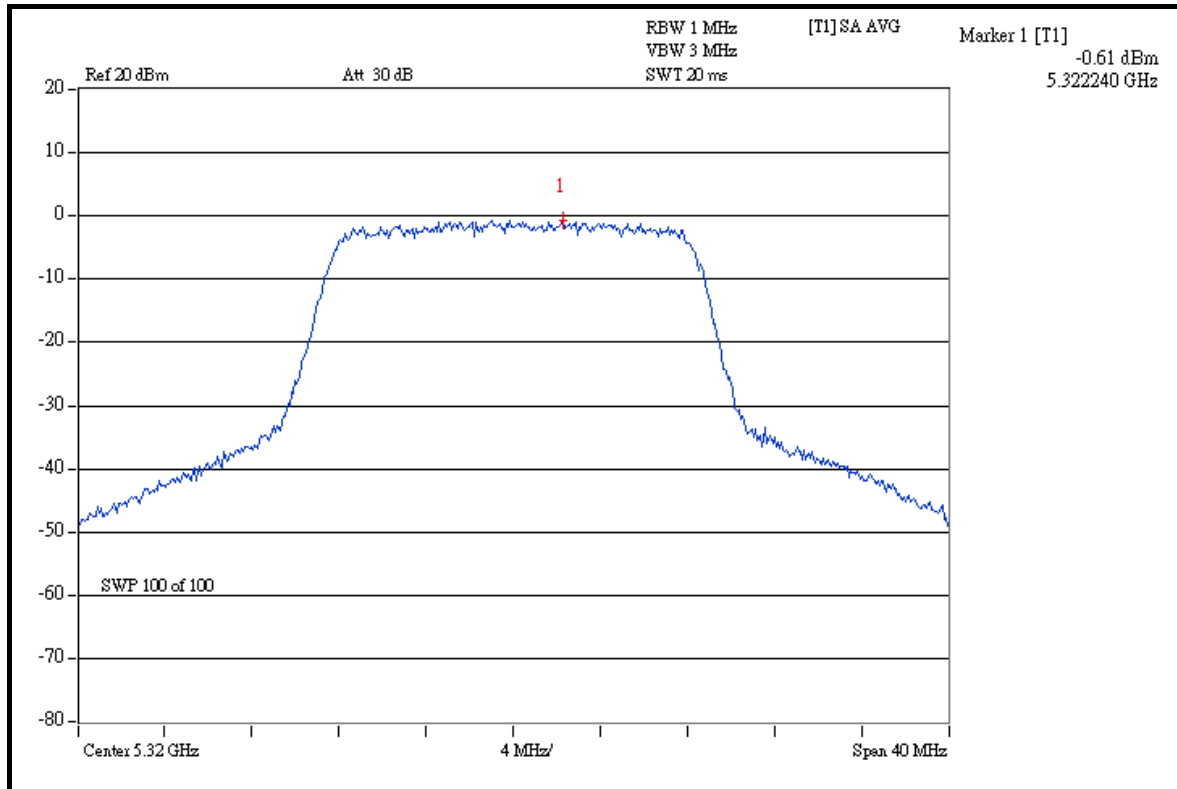

CH 100

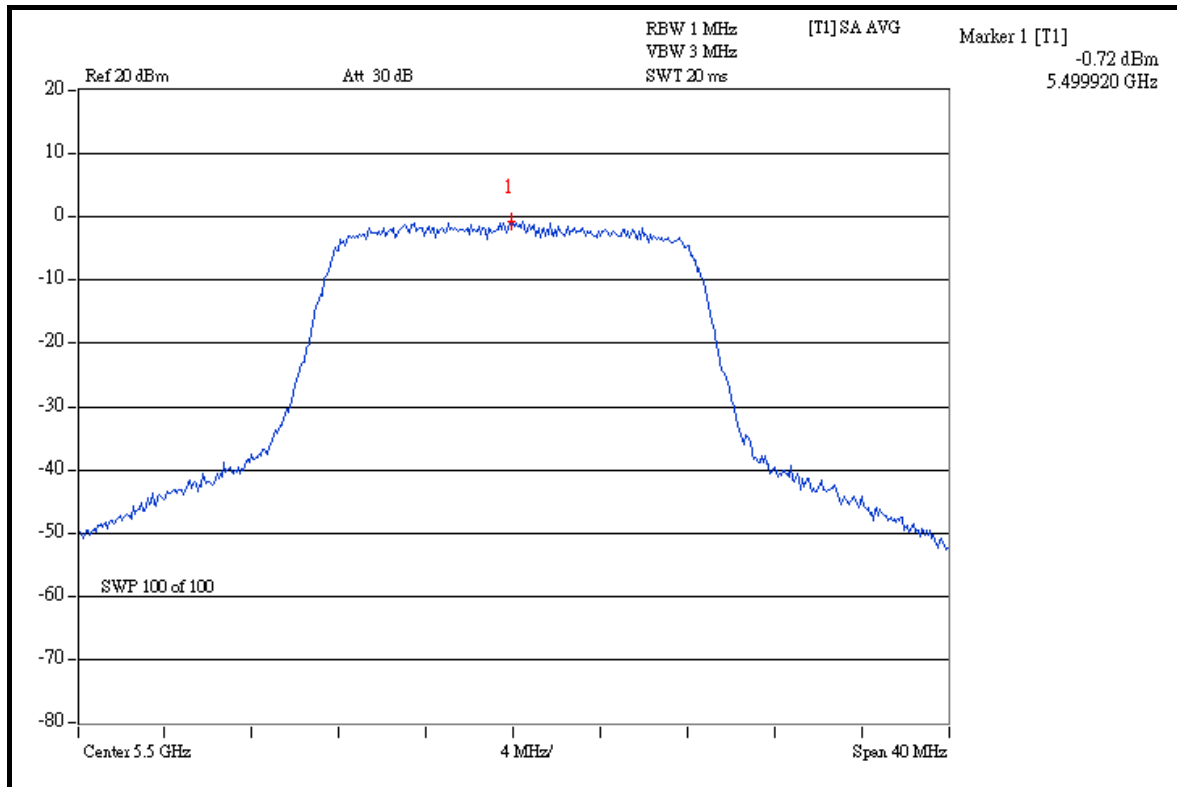



A D T

CH 120

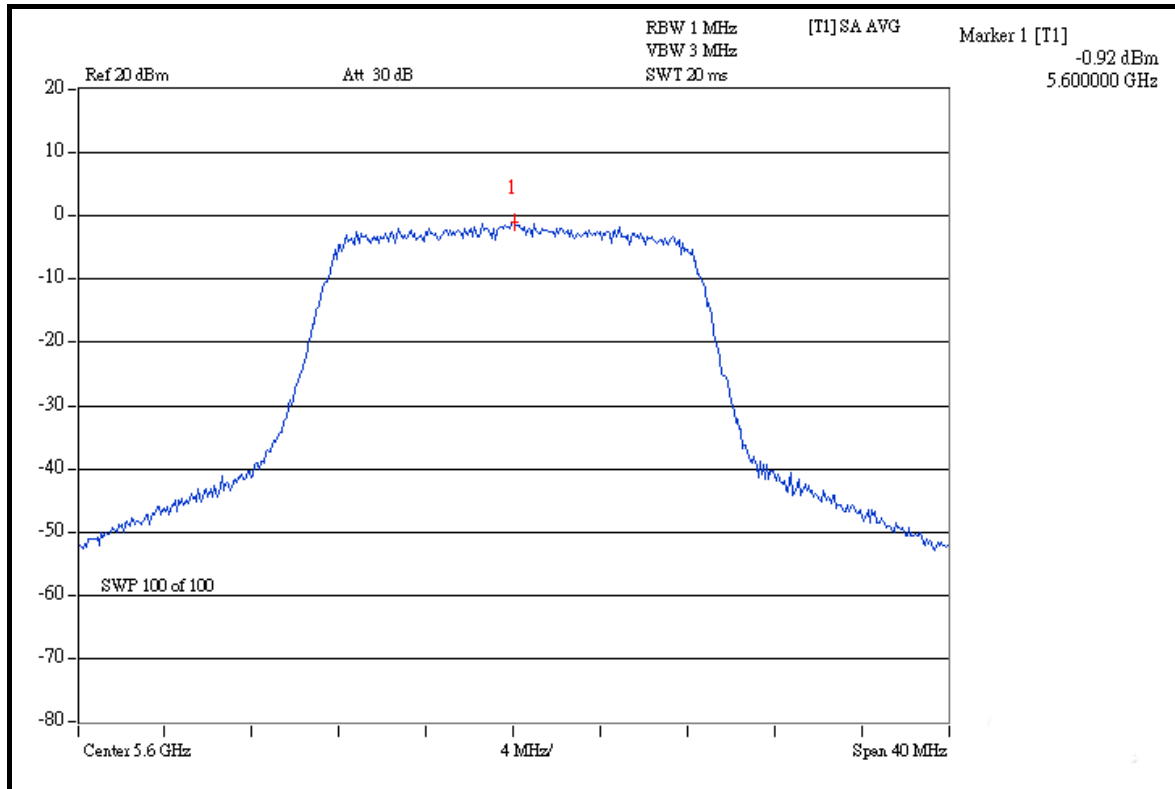

CH 140

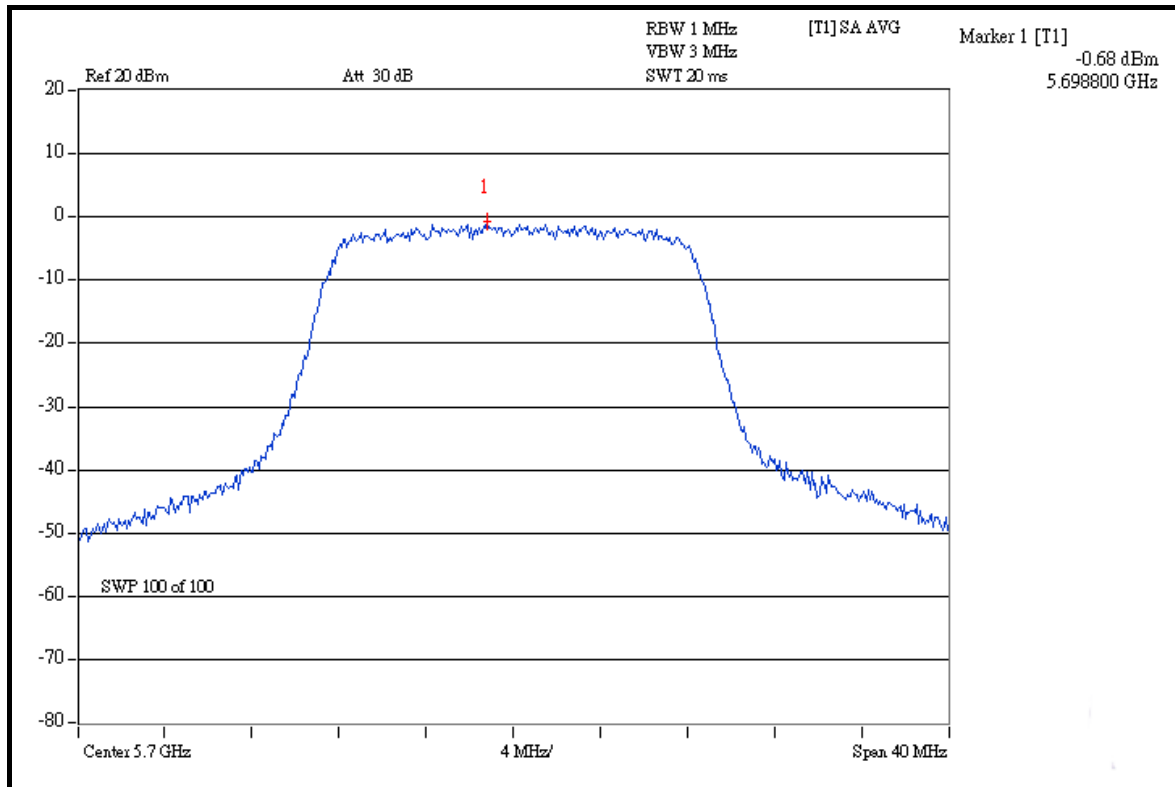



A D T

DRAFT 802.11n (20MHz) OFDM MODULATION

MODULATION TYPE	BPSK	TRANSFER RATE	7.2Mbps
INPUT POWER (SYSTEM)	120Vac, 60Hz	ENVIRONMENTAL CONDITIONS	25 deg.C, 65 %RH, 991hPa
TESTED BY	Brad Wu		

CHAN.	CHAN. FREQ. (MHz)	RF POWER LEVEL IN 3kHz BW (dBm)		TOTAL POWER DENSITY (mW)	TOTAL POWER DENSITY (dBm)	MAX. LIMIT (dBm)	PASS / FAIL
		CHAIN 0	CHAIN 1				
52	5260	-3.80	-3.84	0.830	-0.81	11	PASS
60	5300	-3.59	-3.68	0.866	-0.62	11	PASS
64	5320	-3.60	-3.84	0.850	-0.71	11	PASS
100	5500	-4.10	-3.91	0.795	-0.99	11	PASS
120	5600	-3.86	-3.78	0.830	-0.81	11	PASS
140	5700	-3.99	-3.70	0.826	-0.83	11	PASS



A D T

CHAIN 0: CH 52

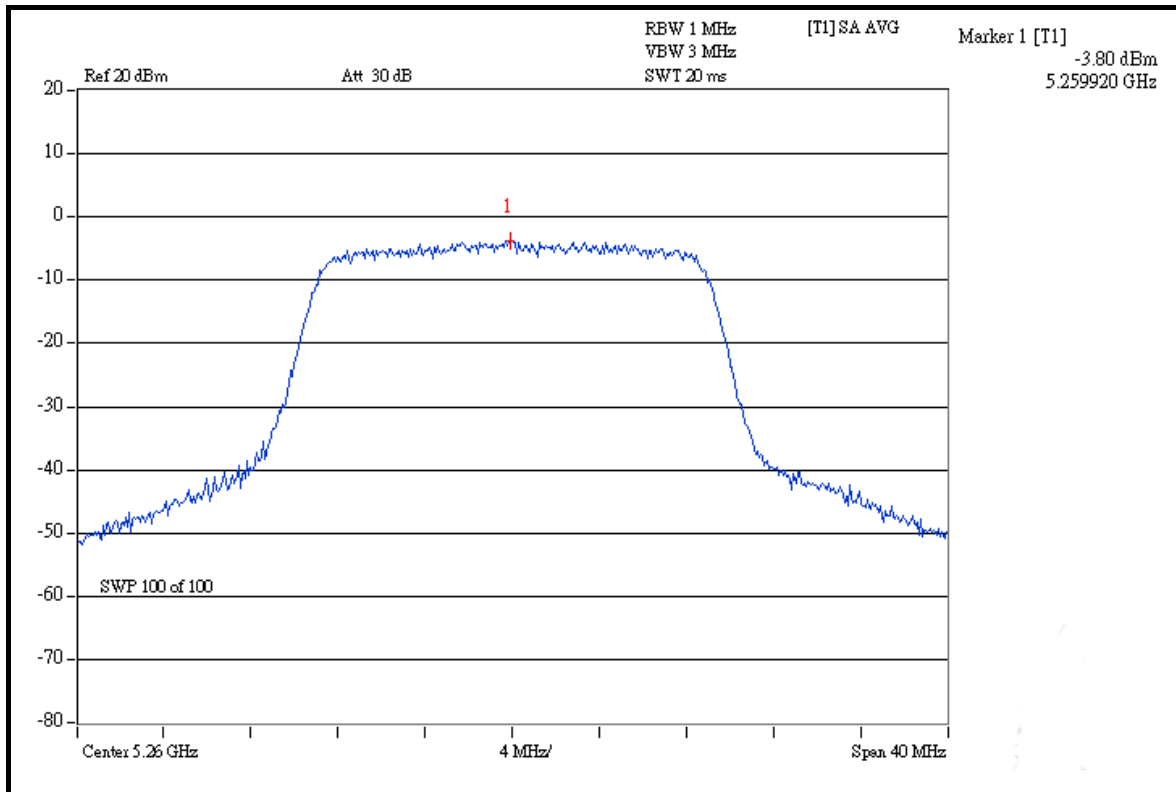

CH 60

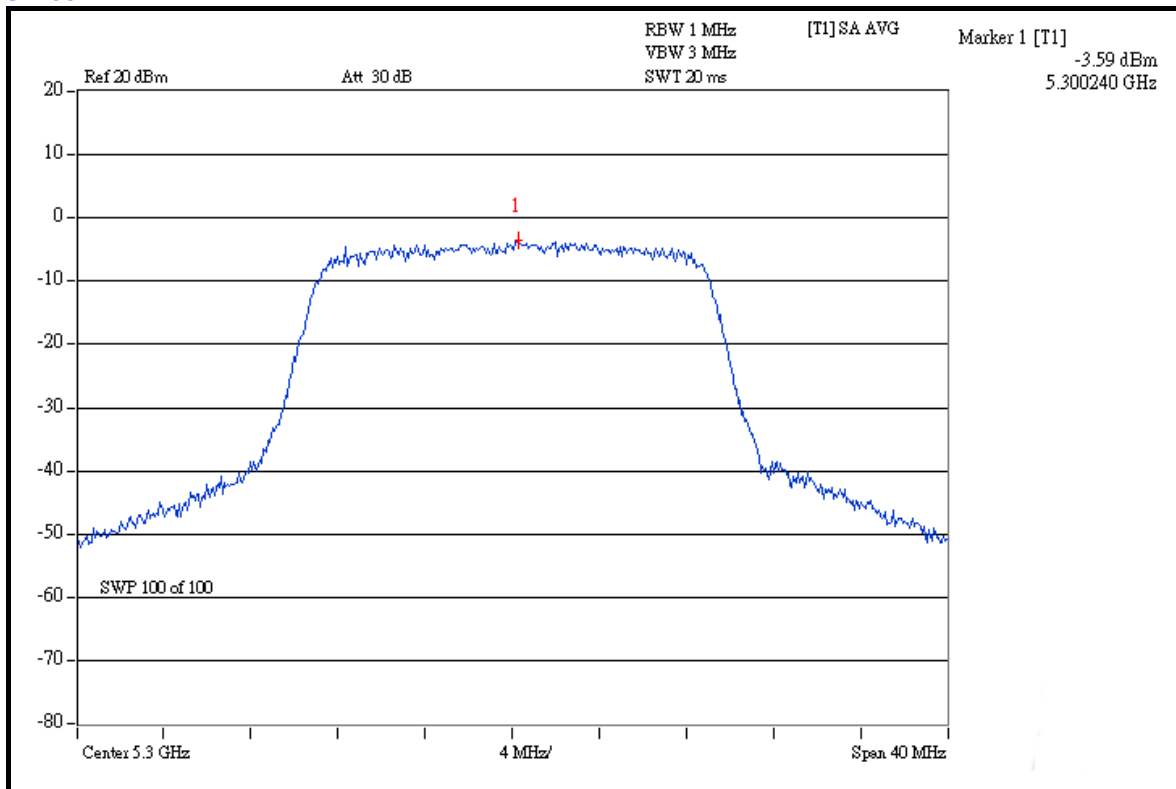



A D T

CH 64

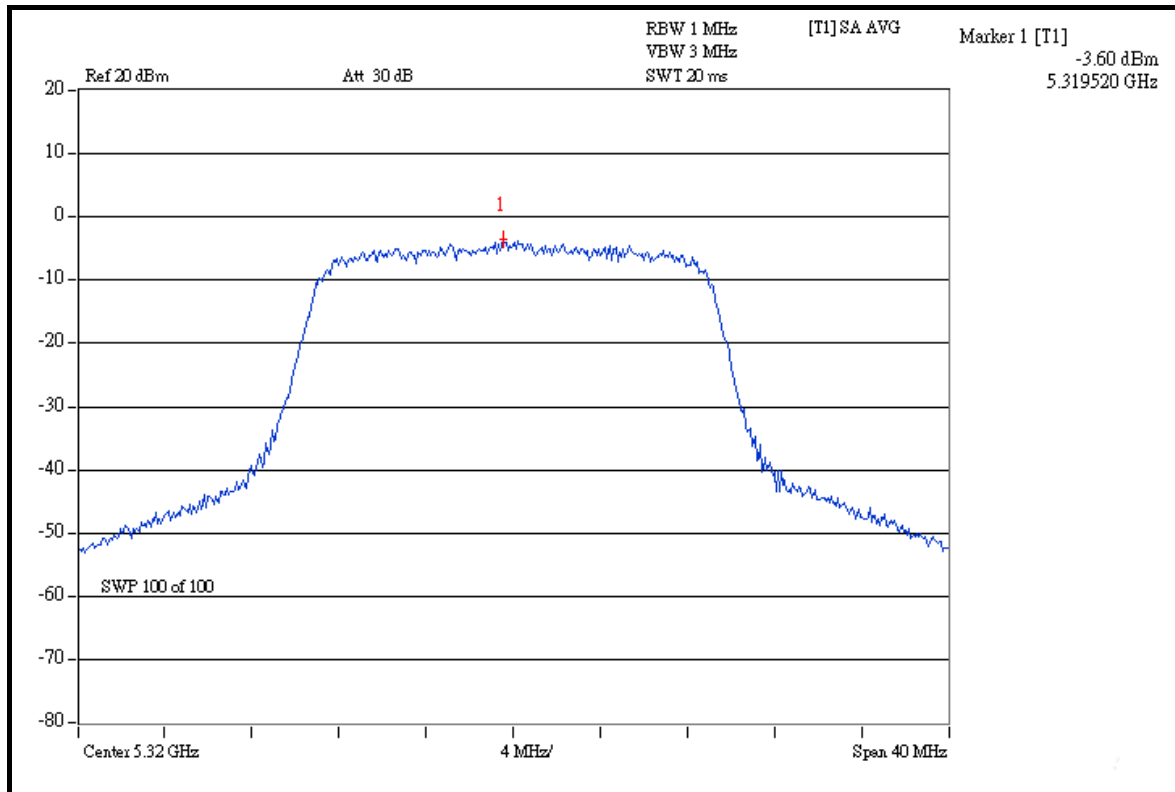

CH 100

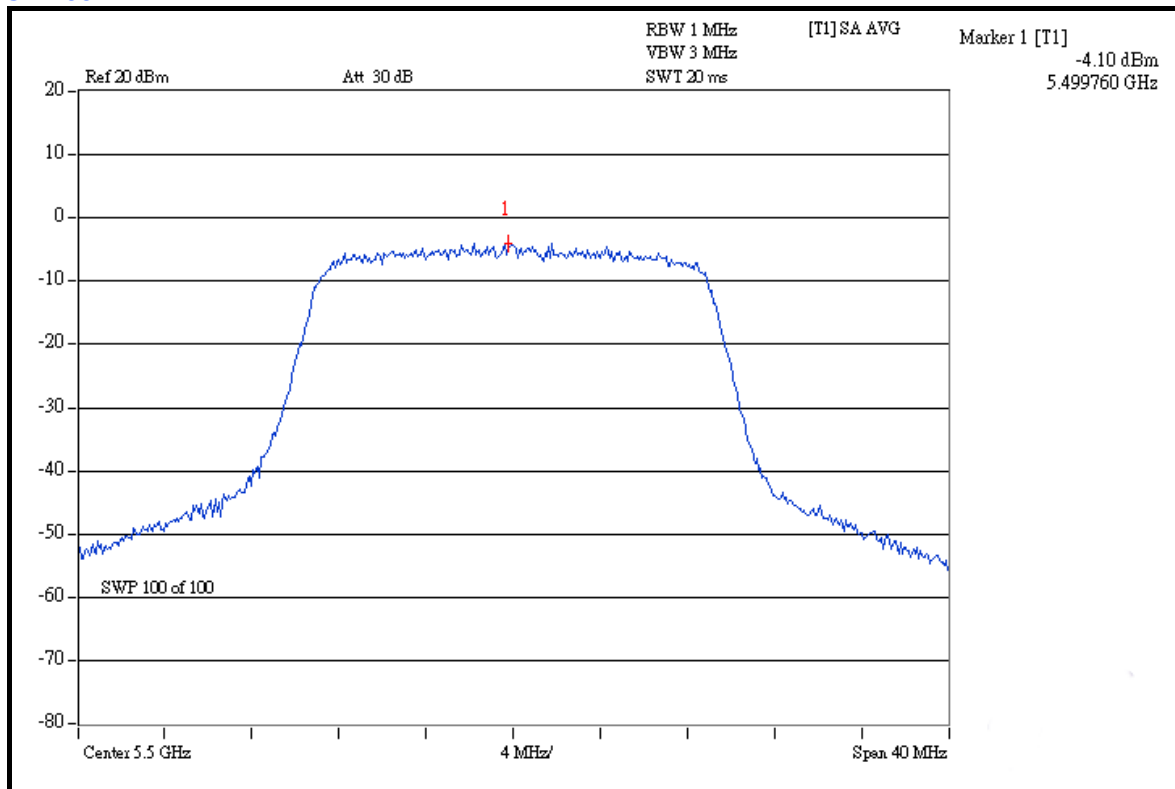



A D T

CH 120

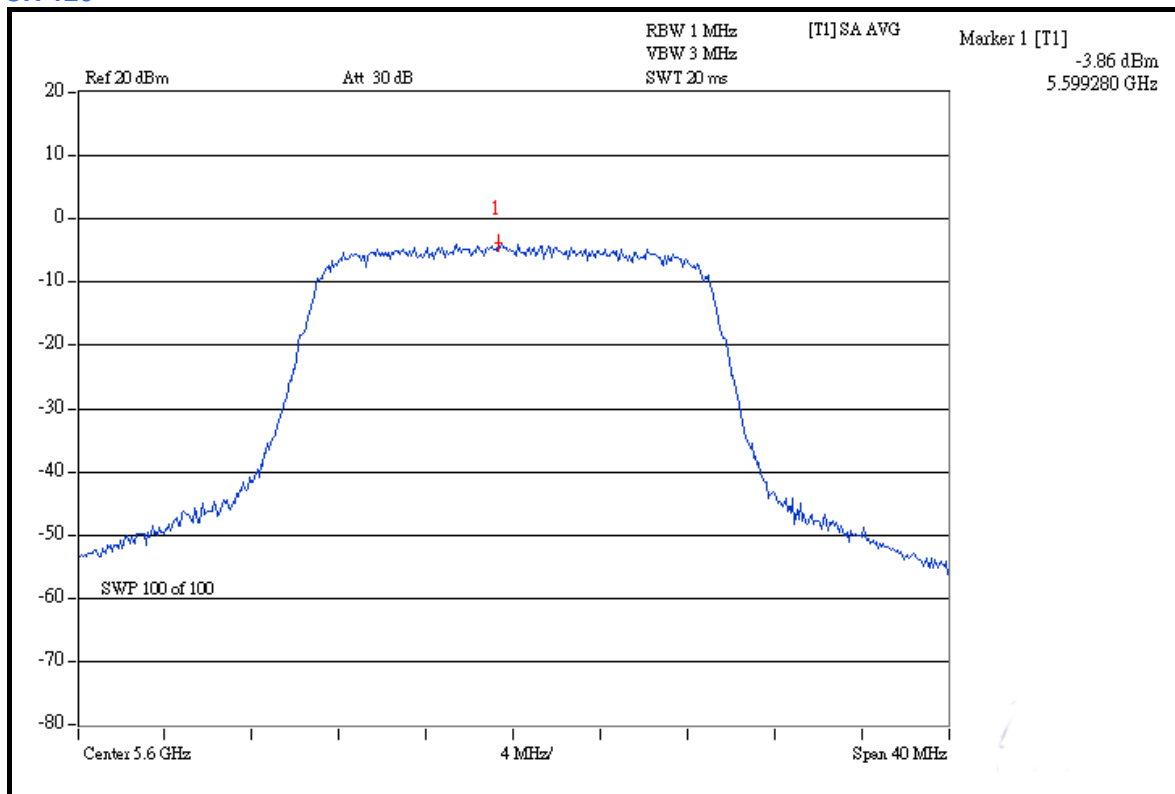

CH 140

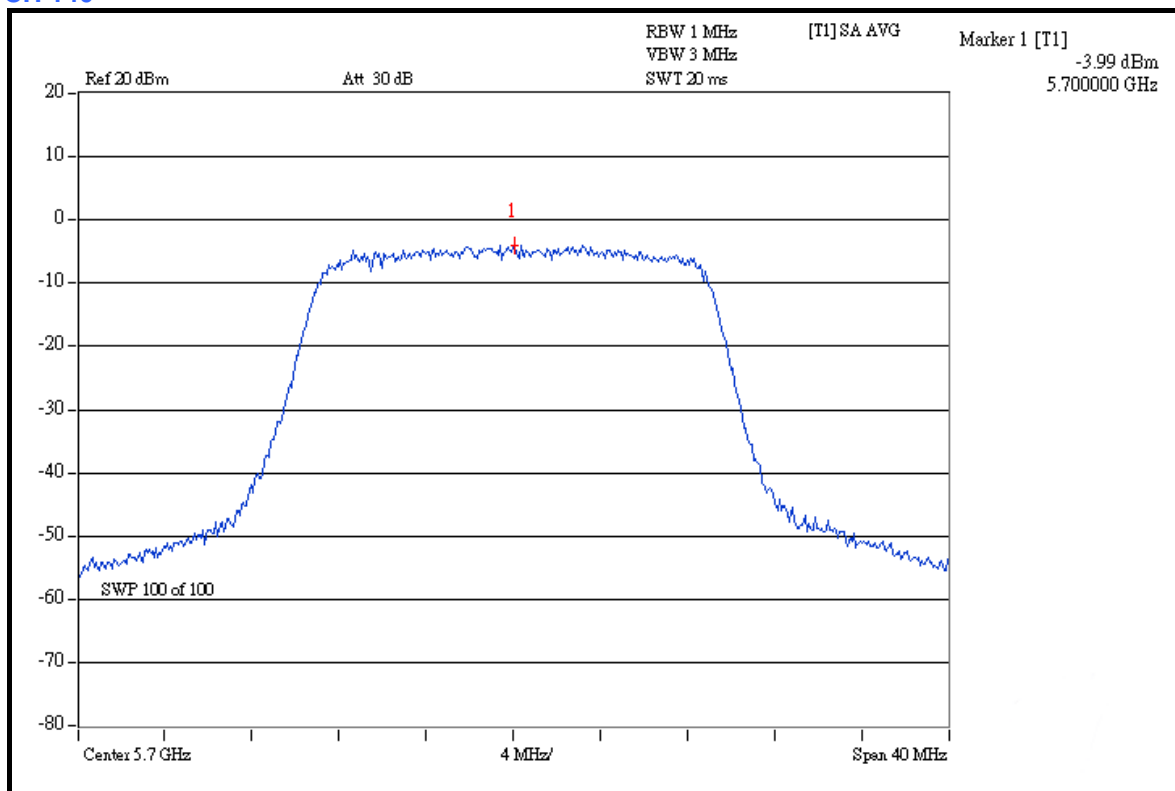



A D T

CHAIN 1: CH 52

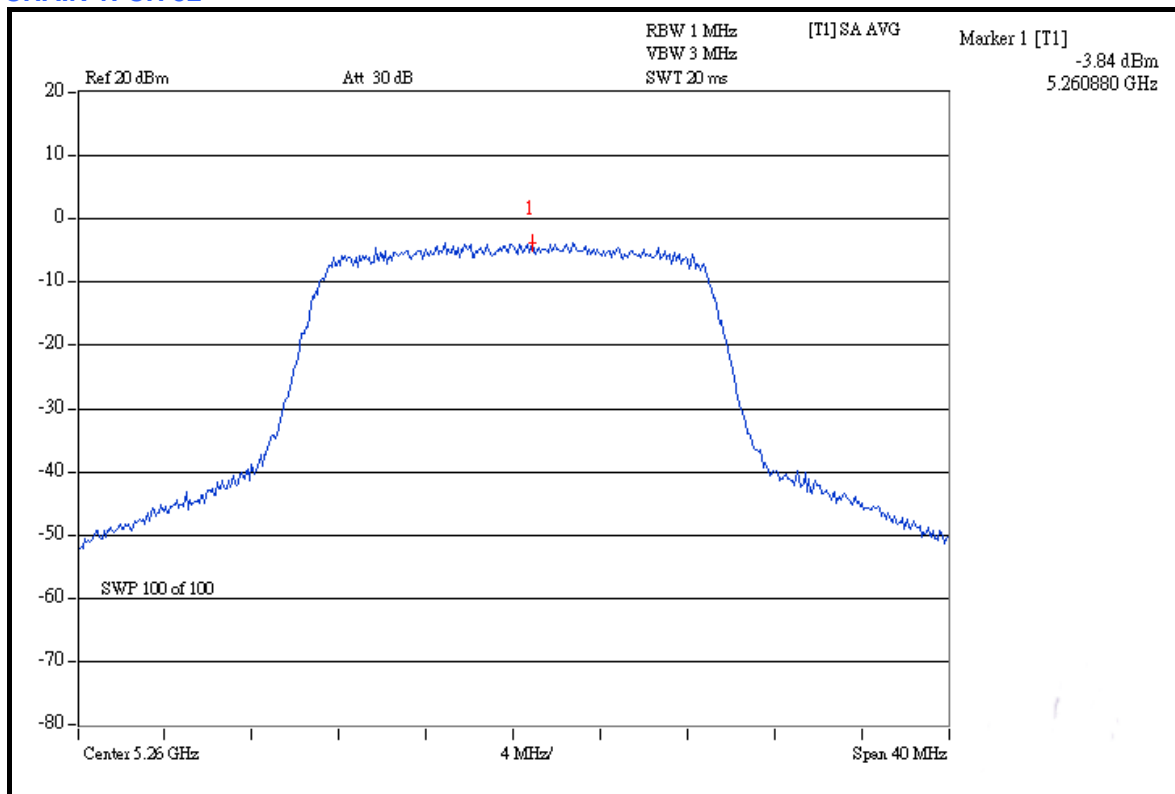

CH 60

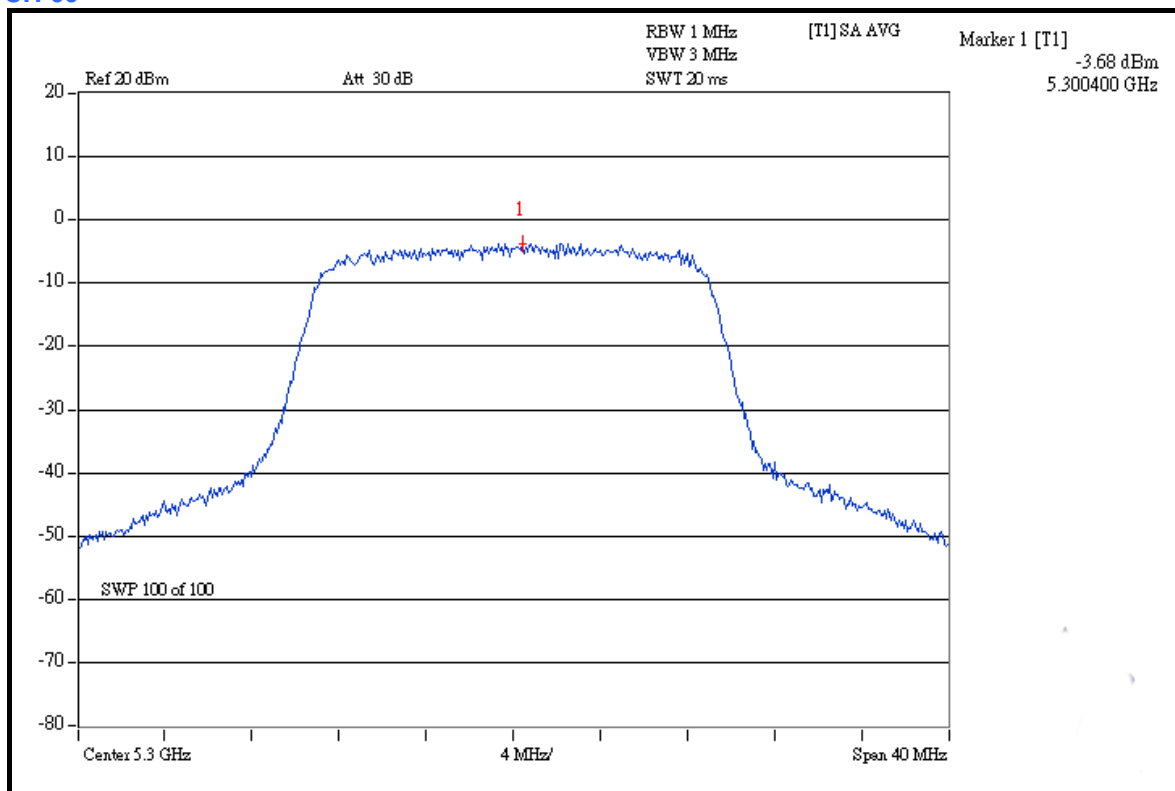



A D T

CH 64

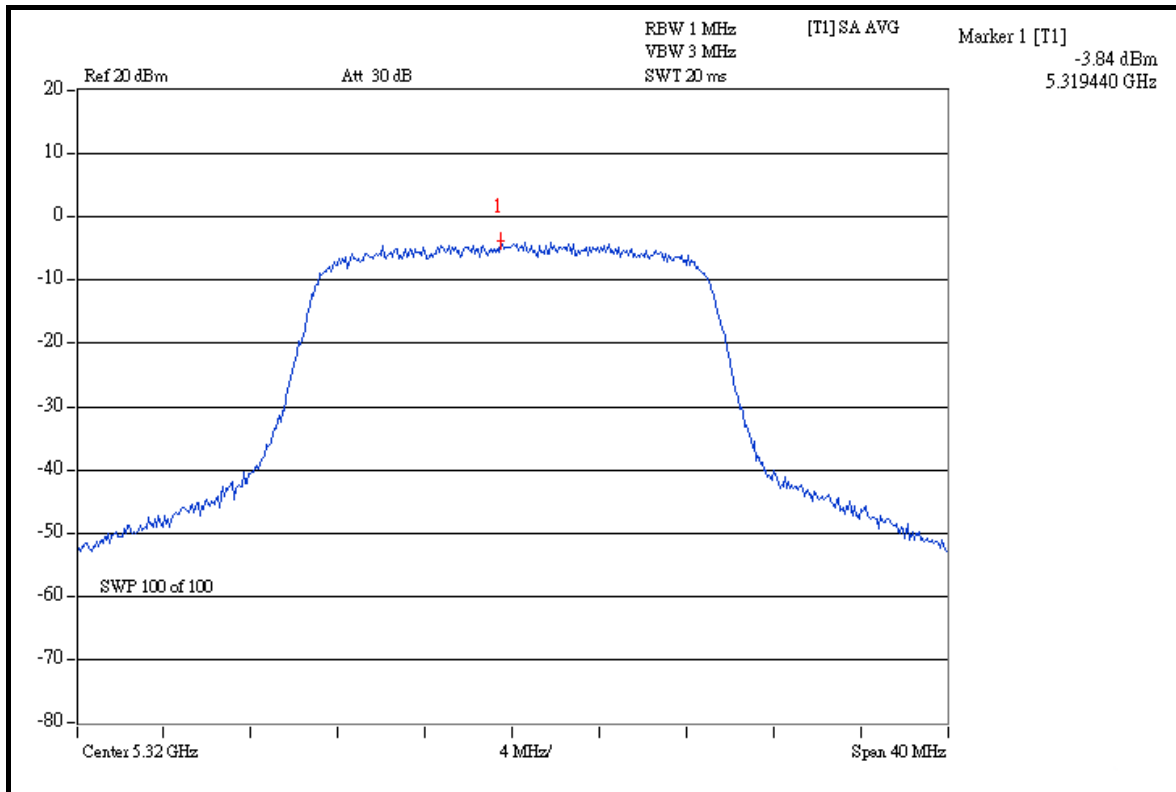

CH 100

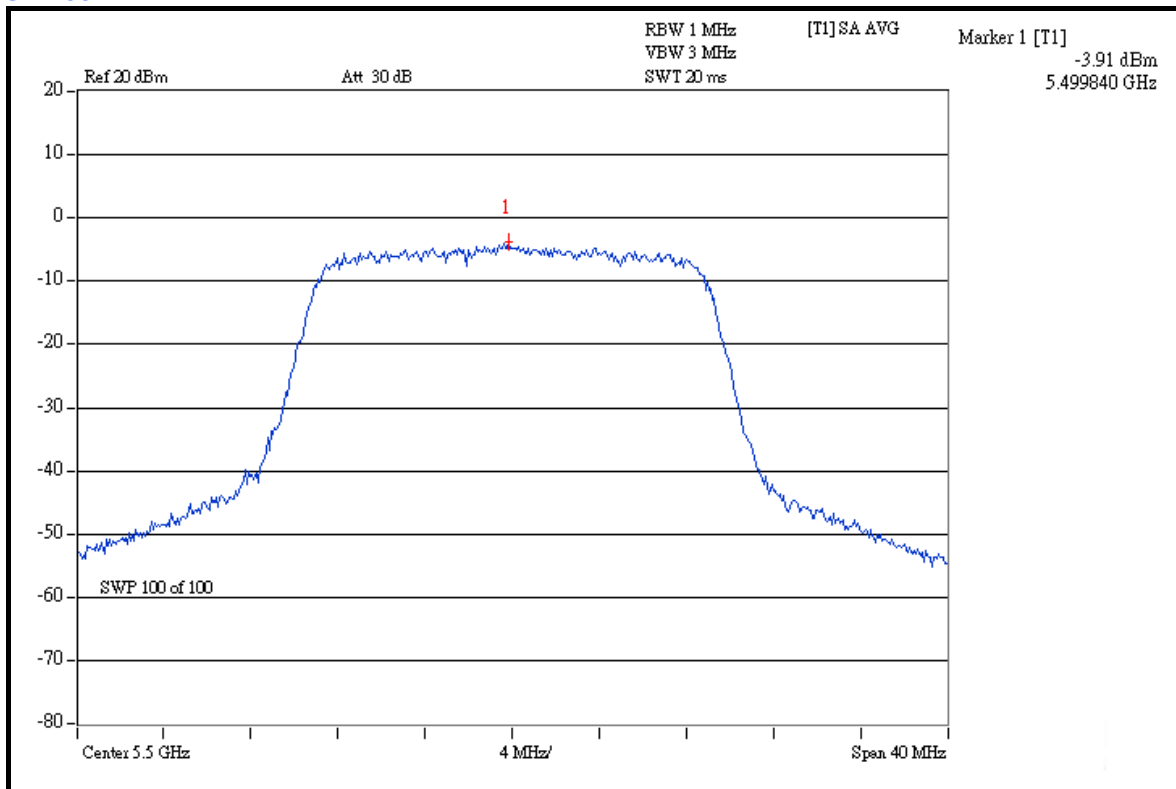



A D T

CH 120

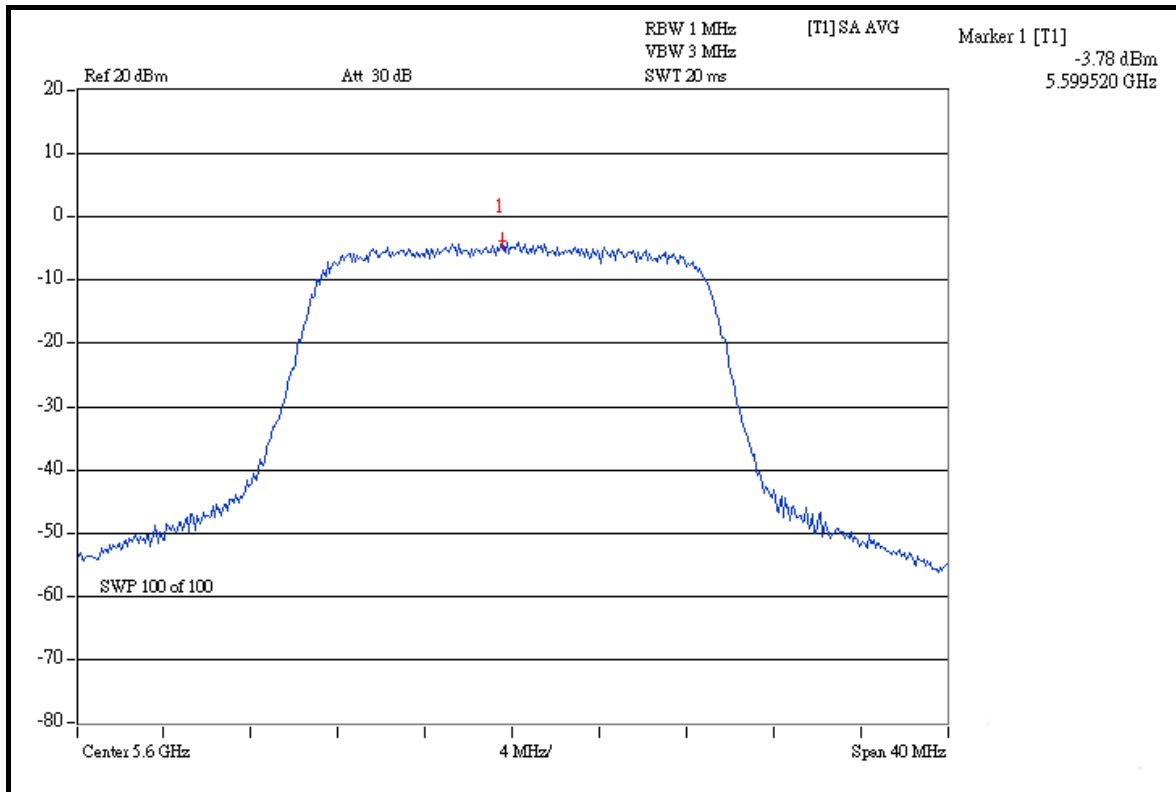

CH 140

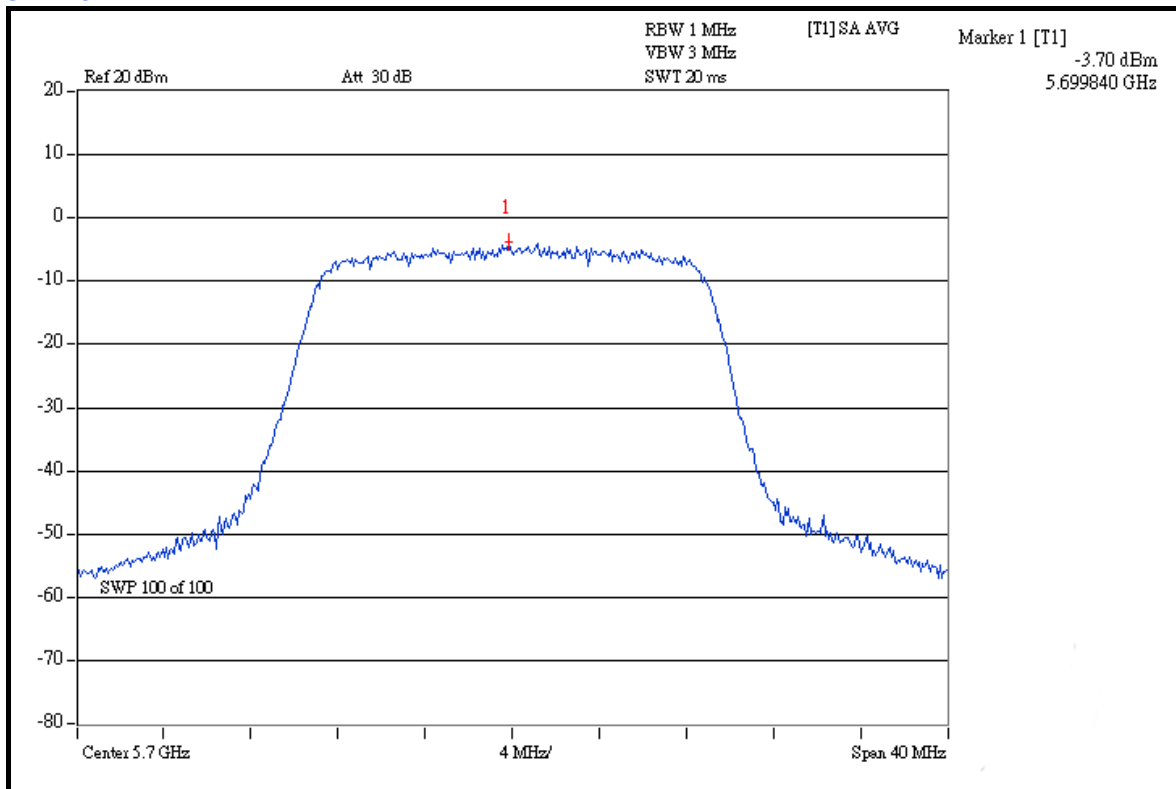



A D T

DRAFT 802.11n (40MHz) OFDM MODULATION

MODULATION TYPE	BPSK	TRANSFER RATE	15.0Mbps
INPUT POWER (SYSTEM)	120Vac, 60Hz	ENVIRONMENTAL CONDITIONS	26 deg.C, 65 %RH, 991hPa
TESTED BY	Brad Wu		

CHAN.	CHAN. FREQ. (MHz)	RF POWER LEVEL IN 3kHz BW (dBm)		TOTAL POWER DENSITY (mW)	TOTAL POWER DENSITY (dBm)	MAX. LIMIT (dBm)	PASS / FAIL
		CHAIN 0	CHAIN 1				
54	5270	-2.10	-1.65	1.301	1.14	11	PASS
62	5310	-3.39	-3.21	0.936	-0.29	11	PASS
102	5510	-3.56	-2.79	0.967	-0.15	11	PASS
118	5590	-4.25	-3.27	0.847	-0.72	11	PASS
134	5670	-3.63	-3.80	0.850	-0.70	11	PASS



A D T

CHAIN 0: CH 54

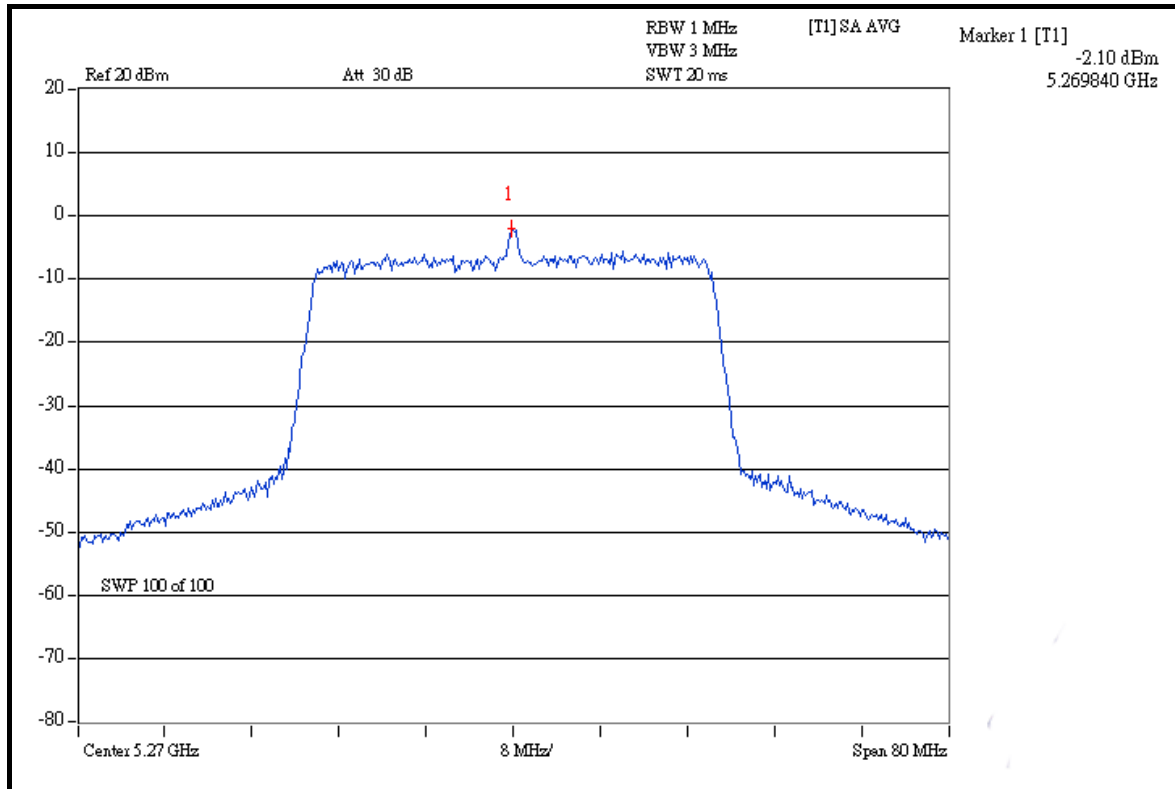

CH 62

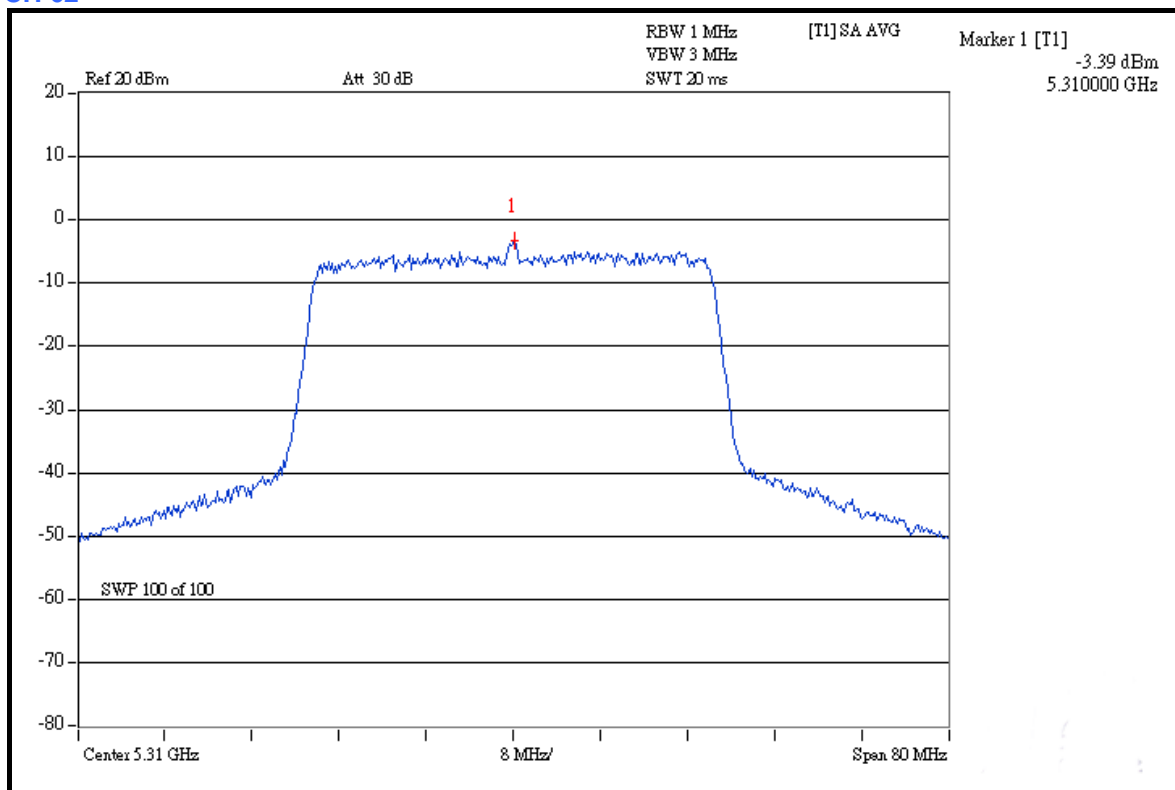



A D T

CH 102

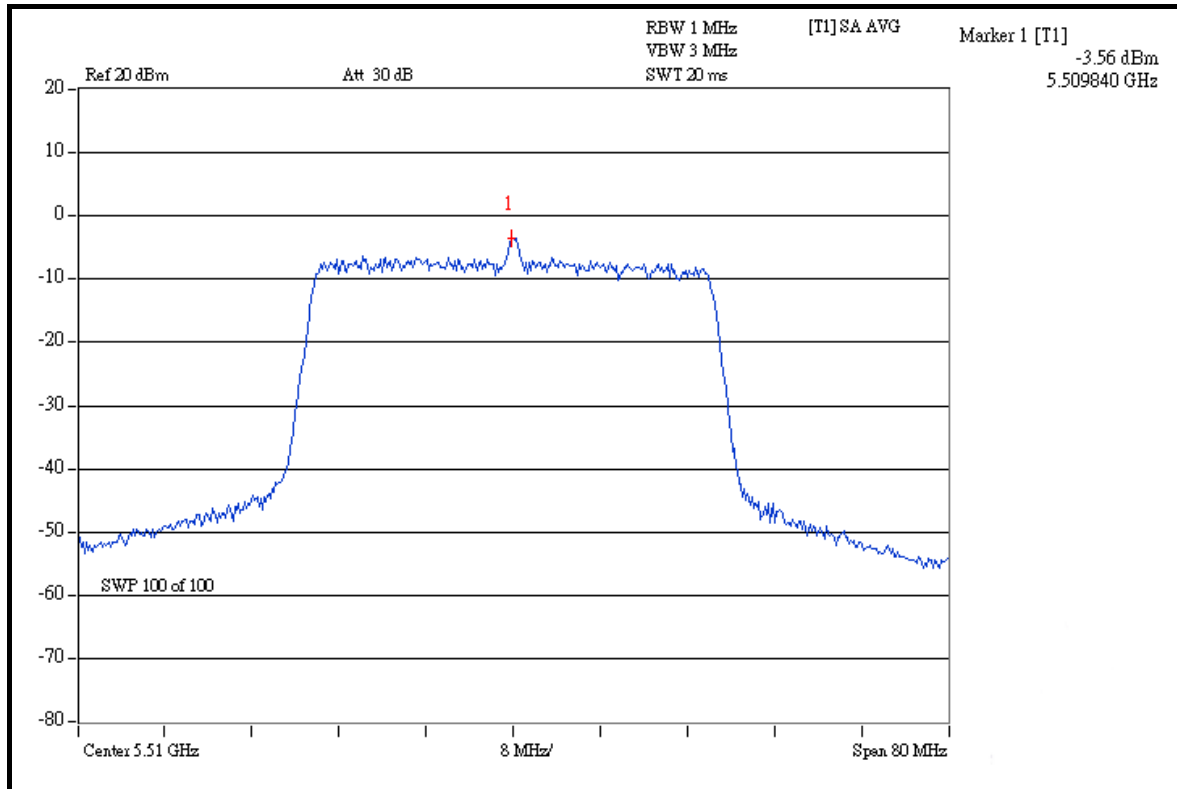

CH 118

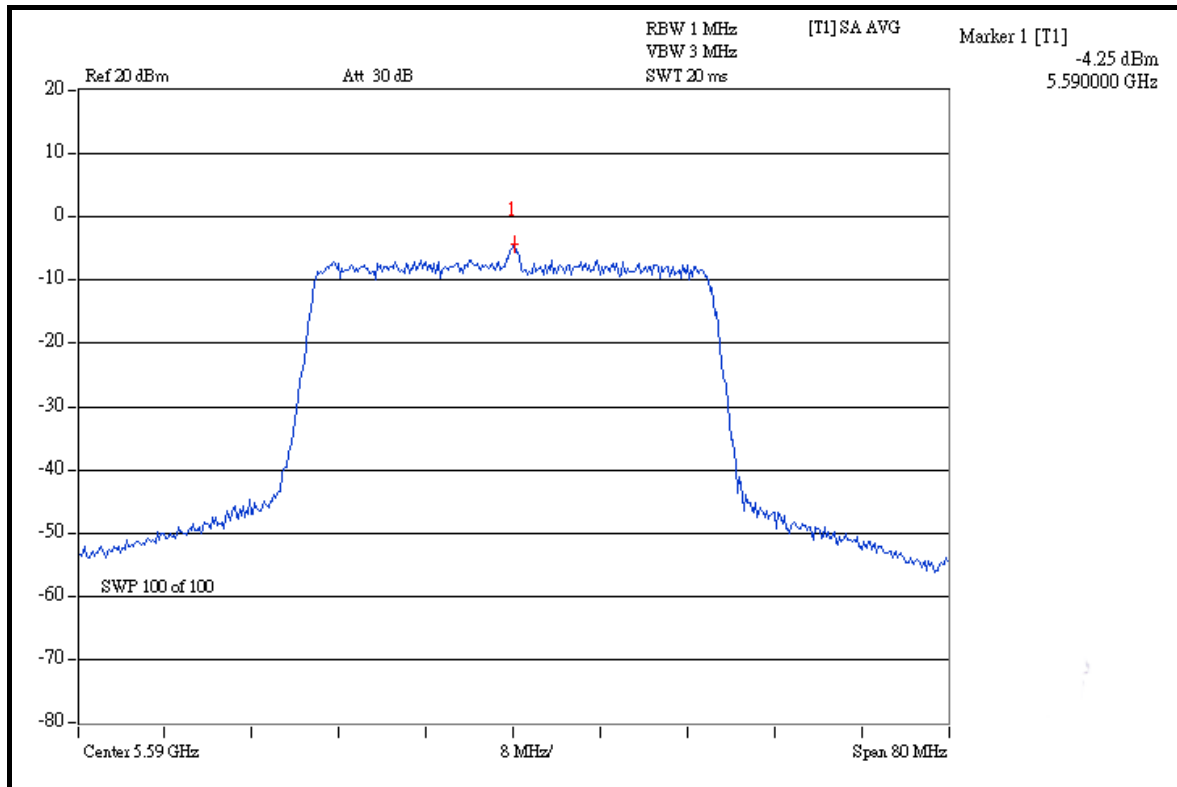



A D T

CH 134

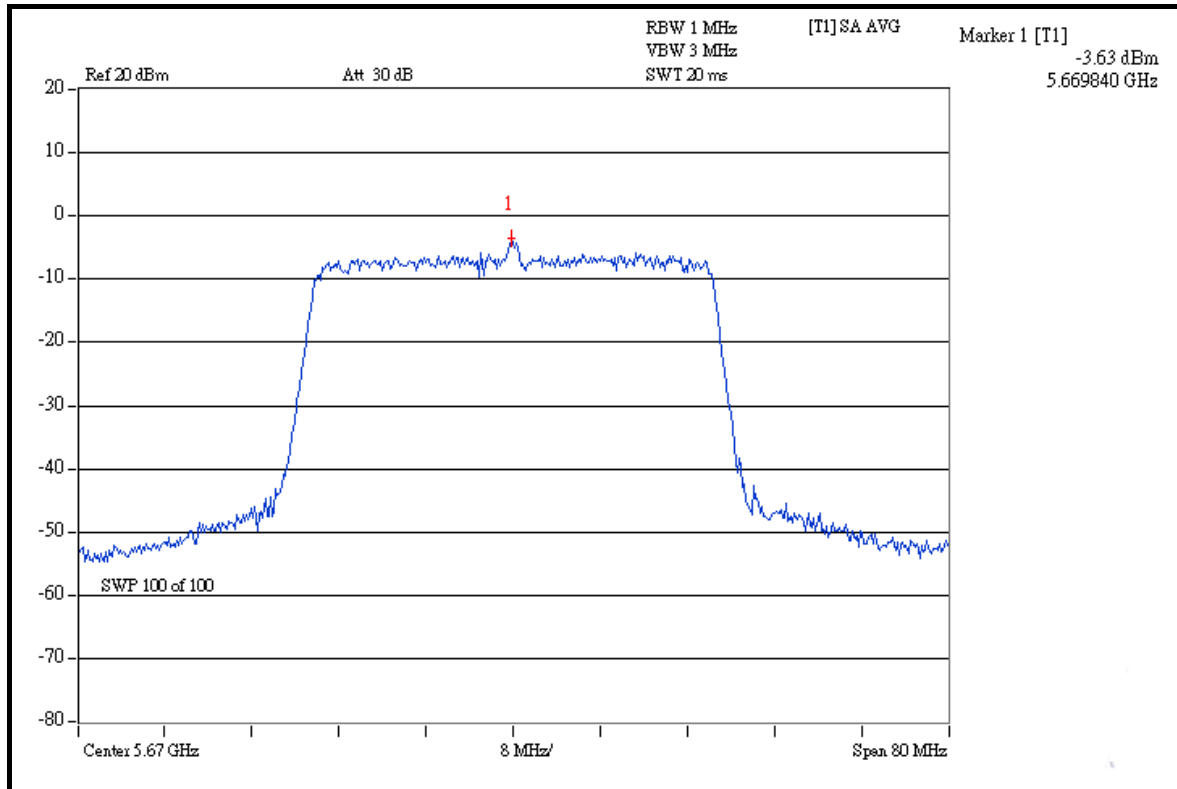

CHAIN 1: CH 54

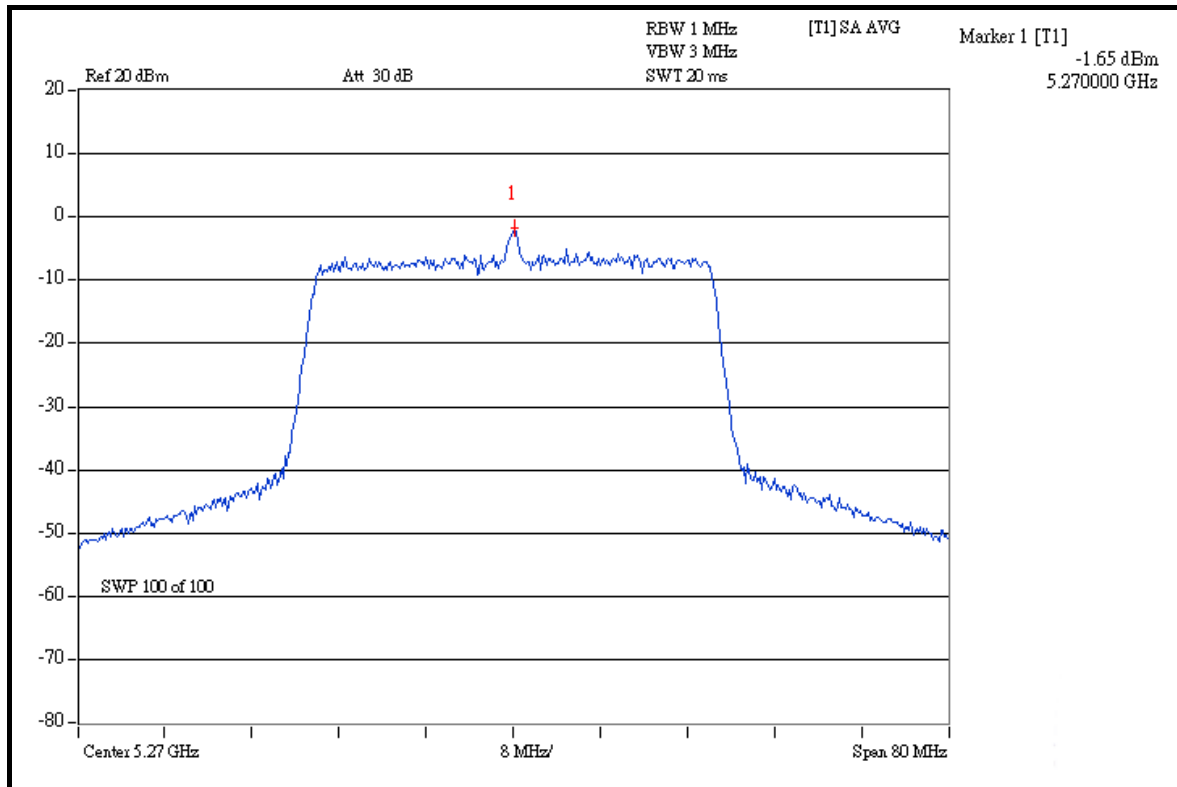



A D T

CH 62

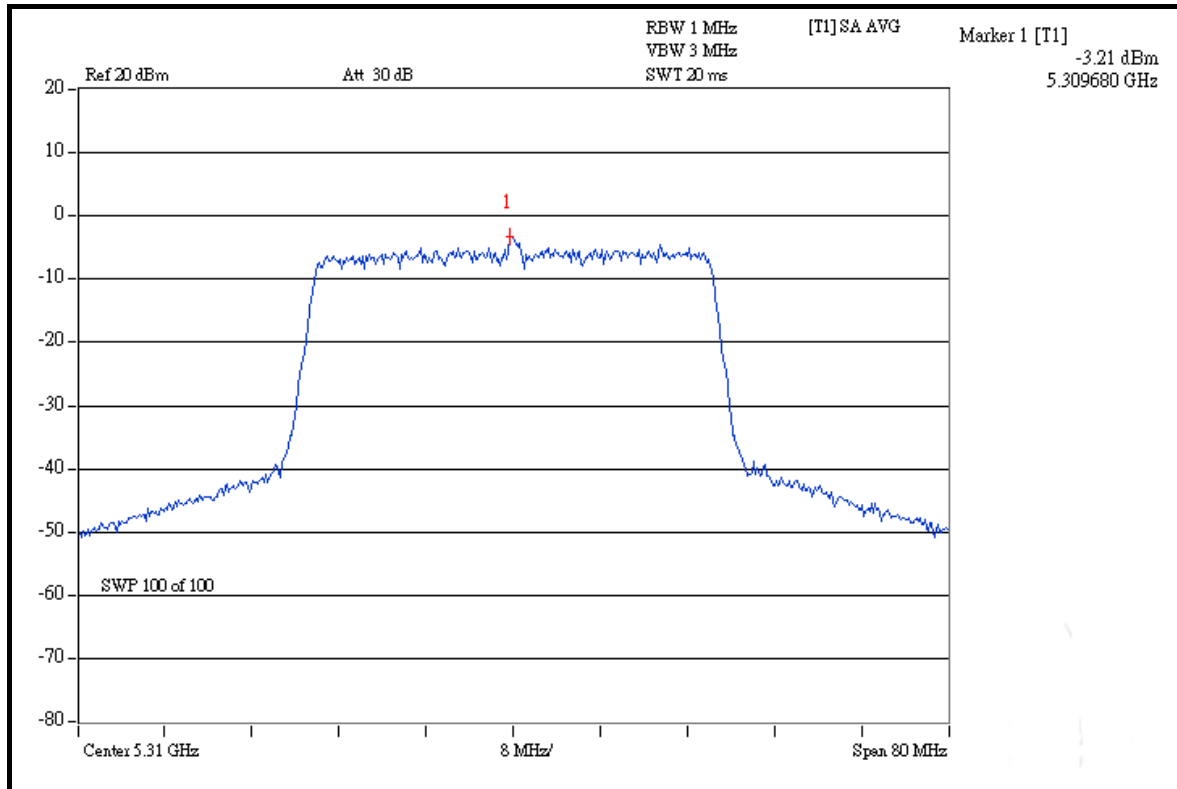

CH 102

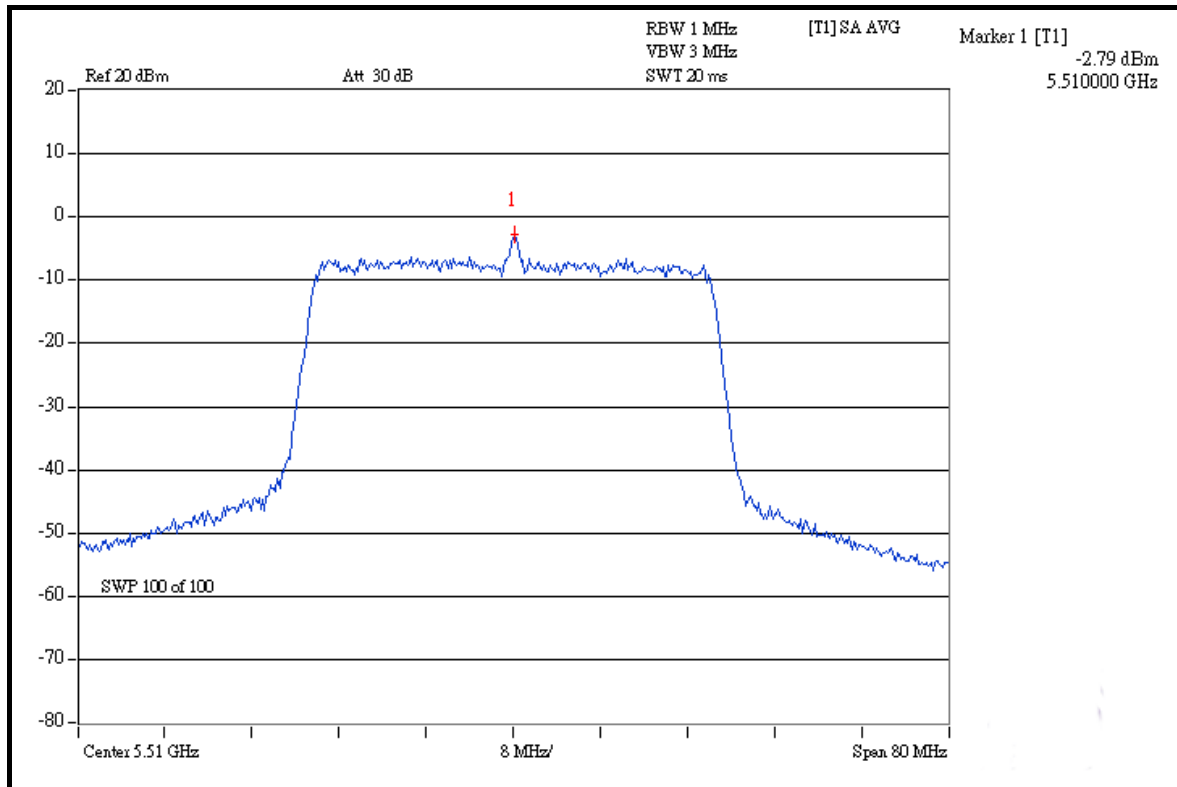



A D T

CH 118

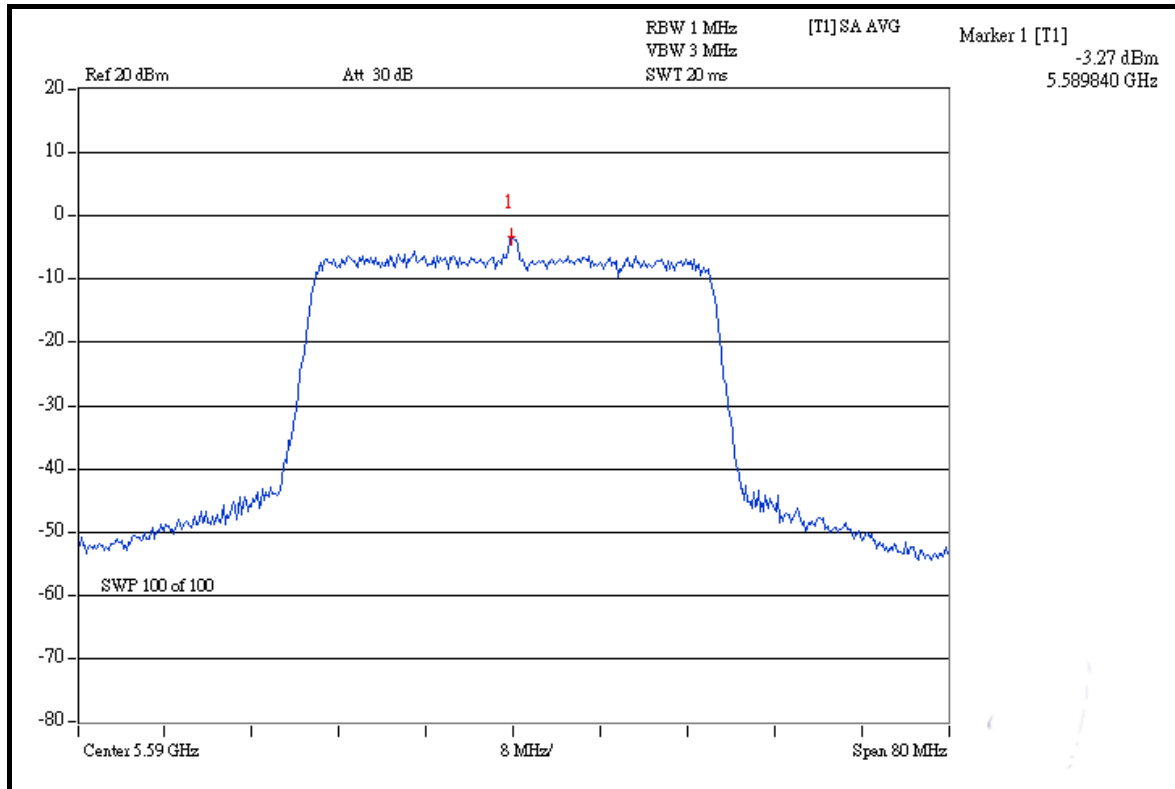

CH 134

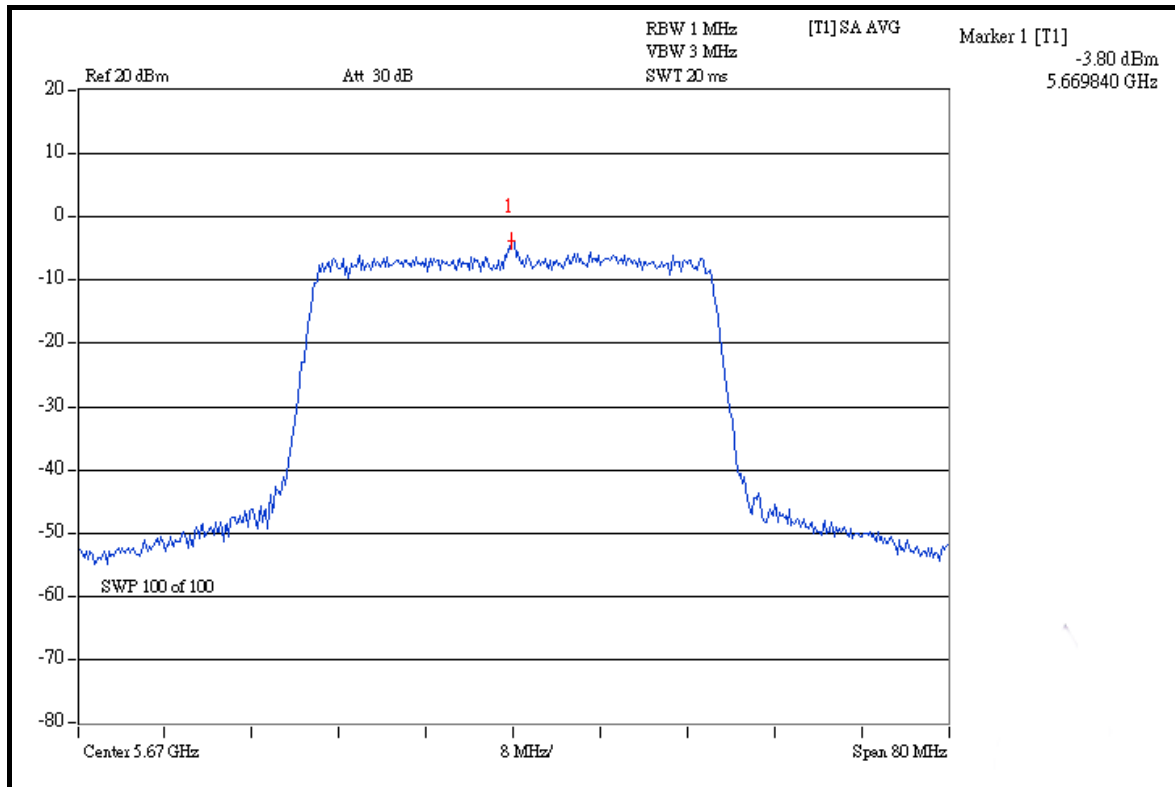

4.6 FREQUENCY STABILITY

4.6.1 LIMITS OF FREQUENCY STABILITY MEASUREMENT

The frequency tolerance of the carrier signal shall be maintained within +/- 0.02% of the operating frequency over a temperature variation of -30 degrees to 50 degrees C at normal supply voltage, and for a variation in the primary supply voltage from 85% to 115% of the rated supply voltage at a temperature of 20 degrees C.

4.6.2 TEST INSTRUMENTS

DESCRIPTION & MANUFACTURER	MODEL NO.	SERIAL NO.	DATE OF CALIBRATION	DUE DATE OF CALIBRATION
ANRITSU SPECTRUM ANALYZER	MS2667C	M10281	Nov. 22, 2007	Nov. 21, 2008
WIT STANDARD TEMPERATURE AND HUMIDITY CHAMBER	TH-4S-C	W981030	Jun. 29, 2007	Jun. 28, 2008

NOTE: The calibration interval of the above test instruments is 12 months and the calibrations are traceable to NML/ROC and NIST/USA.

4.6.3 TEST PROCEDURE

- a. The EUT was placed inside the environmental test chamber and powered by nominal DC voltage.
- b. Turn the EUT on and couple its output to a spectrum analyzer.
- c. Turn the EUT off and set the chamber to the highest temperature specified.
- d. Allow sufficient time (approximately 30 min) for the temperature of the chamber to stabilize, turn the EUT on and measure the operating frequency after 2, 5, and 10 minutes.
- e. Repeat step 2 and 3 with the temperature chamber set to the lowest temperature.
- f. The test chamber was allowed to stabilize at +20 degree C for a minimum of 30 minutes. The supply voltage was then adjusted on the EUT from 85% to 115% and the frequency record.

4.6.4 DEVIATION FROM TEST STANDARD

No deviation

4.6.5 TEST SETUP

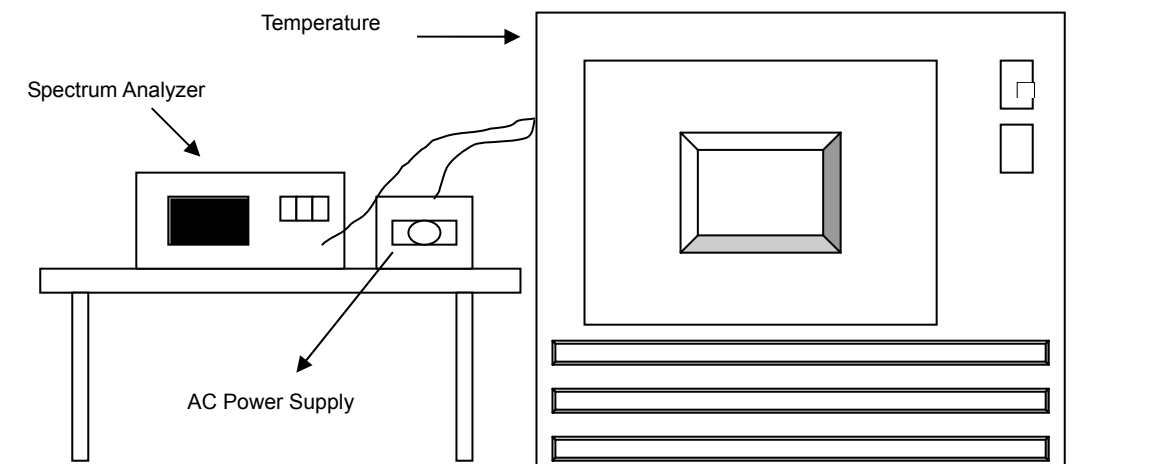

4.6.6 EUT OPERATING CONDITION

Same as Item 4.1.6

4.6.7 TEST RESULTS

OPERATING FREQUENCY: 5320MHz						LIMIT: $\pm 0.01\%$			
TEMP. (°C)	POWER SUPPLY (Vac)	0 MINUTE		2 MINUTE		5 MINUTE		10 MINUTE	
		(MHz)	(%)	(MHz)	(%)	(MHz)	(%)	(MHz)	(%)
50	126.5	5319.921765	-0.0014706	5319.922465	-0.0014574	5319.922305	-0.0014604	5319.918590	-0.0015303
	110.0	5319.927684	-0.0013593	5319.925678	-0.0013970	5319.923416	-0.0014395	5319.925049	-0.0014089
	93.5	5319.942299	-0.0010846	5319.939926	-0.0011292	5319.940668	-0.0011153	5319.938359	-0.0011587
40	126.5	5319.921057	-0.0014839	5319.922578	-0.0014553	5319.922323	-0.0014601	5319.919197	-0.0015189
	110.0	5319.928770	-0.0013389	5319.926499	-0.0013816	5319.925184	-0.0014063	5319.926784	-0.0013762
	93.5	5319.939512	-0.0011370	5319.940736	-0.0011140	5319.938189	-0.0011619	5319.937824	-0.0011687
30	126.5	5319.923557	-0.0014369	5319.924045	-0.0014277	5319.922679	-0.0014534	5319.919069	-0.0015213
	110.0	5319.927849	-0.0013562	5319.931117	-0.0012948	5319.931010	-0.0012968	5319.925836	-0.0013941
	93.5	5319.949432	-0.0009505	5319.944755	-0.0010384	5319.948720	-0.0009639	5319.946717	-0.0010016
20	126.5	5319.928227	-0.0013491	5319.930380	-0.0013086	5319.929196	-0.0013309	5319.928618	-0.0013418
	110.0	5319.933254	-0.0012546	5319.930863	-0.0012996	5319.927431	-0.0013641	5319.926763	-0.0013766
	93.5	5319.953963	-0.0008654	5319.952442	-0.0008939	5319.951432	-0.0009129	5319.953016	-0.0008832
10	126.5	5319.934924	-0.0012232	5319.934598	-0.0012294	5319.934514	-0.0012309	5319.935836	-0.0012061
	110.0	5319.946274	-0.0010099	5319.945190	-0.0010303	5319.943285	-0.0010661	5319.942223	-0.0010860
	93.5	5319.961267	-0.0007281	5319.963540	-0.0006853	5319.958985	-0.0007710	5319.955581	-0.0008349
0	126.5	5319.942618	-0.0010786	5319.942506	-0.0010807	5319.936081	-0.0012015	5319.938127	-0.0011630
	110.0	5319.952540	-0.0008921	5319.952221	-0.0008981	5319.953916	-0.0008662	5319.948871	-0.0009611
	93.5	5319.968325	-0.0005954	5319.964246	-0.0006721	5319.965898	-0.0006410	5319.965960	-0.0006398
-10	126.5	5319.923896	-0.0014305	5319.926187	-0.0013875	5319.922207	-0.0014623	5319.918976	-0.0015230
	110.0	5319.926888	-0.0013743	5319.929839	-0.0013188	5319.930121	-0.0013135	5319.925539	-0.0013996
	93.5	5319.951366	-0.0009142	5319.944801	-0.0010376	5319.949917	-0.0009414	5319.944941	-0.0010349
-20	126.5	5319.931970	-0.0012788	5319.929858	-0.0013185	5319.930887	-0.0012991	5319.926463	-0.0013823
	110.0	5319.931899	-0.0012801	5319.931440	-0.0012887	5319.927563	-0.0013616	5319.927223	-0.0013680
	93.5	5319.956203	-0.0008233	5319.952015	-0.0009020	5319.955071	-0.0008445	5319.951046	-0.0009202
-30	126.5	5319.937305	-0.0011785	5319.934902	-0.0012236	5319.937061	-0.0011831	5319.933911	-0.0012423
	110.0	5319.945006	-0.0010337	5319.942807	-0.0010751	5319.940996	-0.0011091	5319.942765	-0.0010758
	93.5	5319.963804	-0.0006804	5319.961935	-0.0007155	5319.940996	-0.0011091	5319.958551	-0.0007791

4.7 BAND EDGES MEASUREMENT

4.7.1 TEST INSTRUMENTS

DESCRIPTION & MANUFACTURER	MODEL NO.	SERIAL NO.	DATE OF CALIBRATION	DUE DATE OF CALIBRATION
FOR CONDUCTED MEASUREMENT:				
R&S SPECTRUM ANALYZER	FSP40	100040	Jun. 29, 2007	Jun. 28, 2008
FOR RADIATED MEASUREMENT:				
Test Receiver ROHDE & SCHWARZ	ESIB7	100212	May 28, 2008	May 27, 2009
Spectrum Analyzer ROHDE & SCHWARZ	FSP40	100269	Aug. 06, 2007	Aug. 05, 2008
BILOG Antenna SCHWARZBECK	VULB9168	9168-153	Jan. 04, 2008	Jan. 03, 2009
HORN Antenna SCHWARZBECK	BBHA 9120 D	9120D-563	Jul. 31, 2007	Jul. 30, 2008
HORN Antenna SCHWARZBECK	BBHA 9170	BBHA9170242	Jan. 07, 2008	Jan. 06, 2009
Preamplifier Agilent	8449B	3008A01910	Sep. 20, 2007	Sep. 19, 2008
Preamplifier Agilent	8447D	2944A10638	Dec. 20, 2007	Dec. 19, 2008
RF signal cable HUBER+SUHNNER	SUCOFLEX 104	274039/223650	Nov. 08, 2007	Nov. 07, 2008
RF signal cable Worken	8D-FB	Cable-HYCH9-01	Aug. 10, 2007	Aug. 09, 2008
Software	ADT Radiated V7.6	NA	NA	NA
Antenna Tower EMCO	2070/2080	512.835.4684	NA	NA
Turn Table EMCO	2087-2.03	NA	NA	NA
Antenna Tower & Turn Table Controller EMCO	2090	NA	NA	NA
26GHz ~ 40GHz Amplifier	EM26400	07026401	May 06, 2008	May 05, 2009

NOTE: The calibration interval of the above test instruments is 12 months and the calibrations are traceable to NML/ROC and NIST/USA.

4.7.2 TEST PROCEDURE

FOR CONDUCTED MEASUREMENT:

The transmitter output was connected to the spectrum analyzer via a low lose cable. Set both RBW and VBW of spectrum analyzer to 1MHz and 3MHz with suitable frequency span including 100MHz bandwidth from band edge. The band edges was measured and recorded.

FOR RADIATED MEASUREMENT:

- a. The EUT was placed on the top of a rotating table 0.8 meters above the ground at a 3 meter semi-anechoic chamber. The table was rotated 360 degrees to determine the position of the highest radiation.
- b. The EUT was set 3 meters away from the interference-receiving antenna, which was mounted on the top of a variable-height antenna tower.
- c. The antenna is a broadband antenna, and its height is varied from one meter to four meters above the ground to determine the maximum value of the field strength. Both horizontal and vertical polarizations of the antenna are set to make the measurement.
- d. For each suspected emission, the EUT was arranged to its worst case and then the antenna was tuned to heights from 1 meter to 4 meters and the rotatable table was turned from 0 degrees to 360 degrees to find the maximum reading.
- e. Set both RBW and VBW of spectrum analyzer to 1MHz and 3MHz with suitable frequency span including 100MHz bandwidth from band edge. The band edges was measured and recorded.

NOTE: The resolution bandwidth of test receiver/spectrum analyzer is 1MHz and the video bandwidth is 10Hz for Average detection (AV) at frequency above 1GHz

4.7.3 EUT OPERATING CONDITION

The software provided by client to enable the EUT under transmission condition continuously at specific channel frequencies individually.

4.7.4 TEST RESULTS

For signals in the restricted bands above and below the 5.25 to 5.35GHz and 5.47 to 5.725GHz allocated band a measurement was made of the amplitude of the spurious emissions with respect to the intentional signals. The relative amplitude, in dBc, was applied to the average and peak field strength of the intentional signal made on the OATS to calculate the field strength of the unintentional signals.

The spectrum plots (Peak RBW = 1MHz, VBW = 3MHz) are attached on the following pages.

FOR 5250-5350MHz BAND: 802.11a OFDM MODULATION

Channel 52 (5260MHz)

The band edge emission plot on the next page shows 57.57dBc between carrier maximum power and local maximum emission in restrict band. The emission of carrier strength list in the test result of channel 52 is 111.61dBuV/m (Peak), so the maximum field strength in restrict band is $111.61 - 57.57 = 54.04$ dBuV/m which is under 74dBuV/m limit.

The band edge emission plot on the next page shows 58.83dBc between carrier maximum power and local maximum emission in restrict band. The emission of carrier strength list in the test result of channel 52 is 100.76dBuV/m (Average), so the maximum field strength in restrict band is $100.76 - 58.83 = 41.93$ dBuV/m which is under 54dBuV/m limit.

Channel 64 (5320MHz)

The band edge emission plot on the next second page shows 50.80dBc between carrier maximum power and local maximum emission in restrict band. The emission of carrier strength list in the test result of channel 64 is 111.01dBuV/m (Peak), so the maximum field strength in restrict band is $111.01 - 50.80 = 60.21$ dBuV/m which is under 74dBuV/m limit.

The band edge emission plot on the next third page shows 56.76dBc between carrier maximum power and local maximum emission in restrict band. The emission of carrier strength list in the test result of channel 64 is 100.22dBuV/m (Average), so the maximum field strength in restrict band is $100.22 - 56.76 = 43.46$ dBuV/m which is under 54dBuV/m limit.



A D T

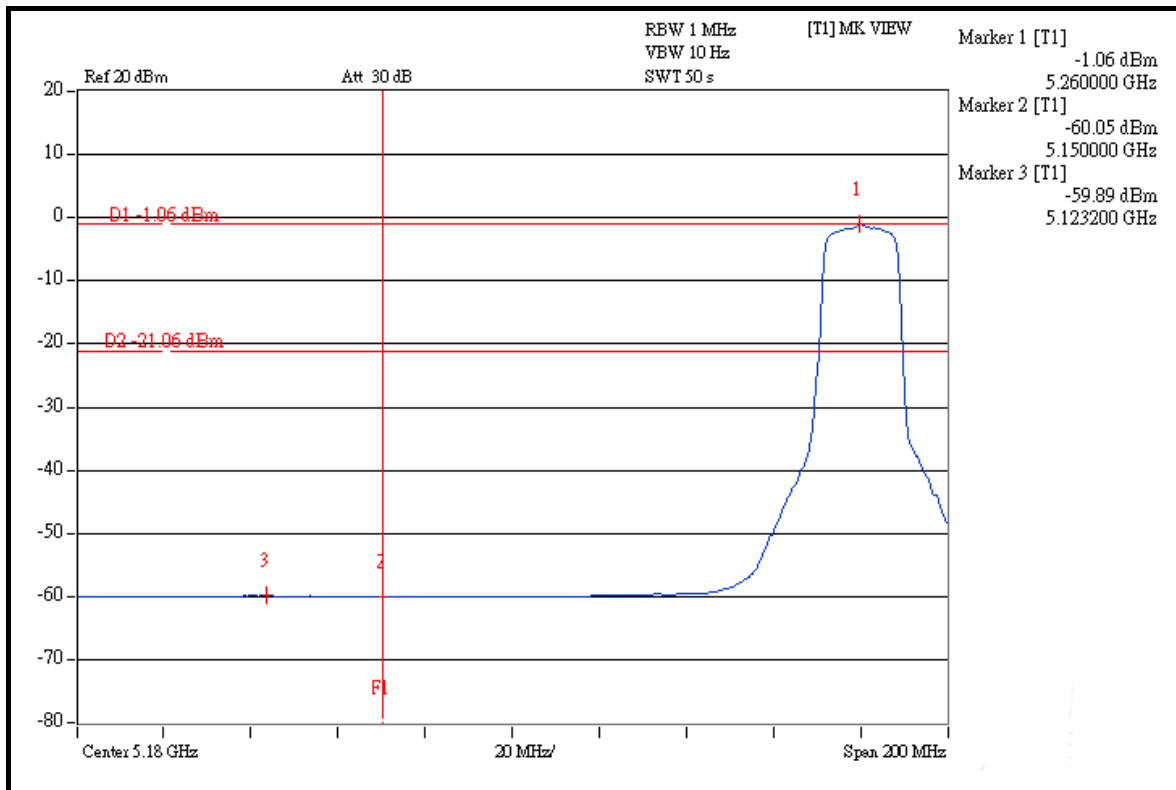
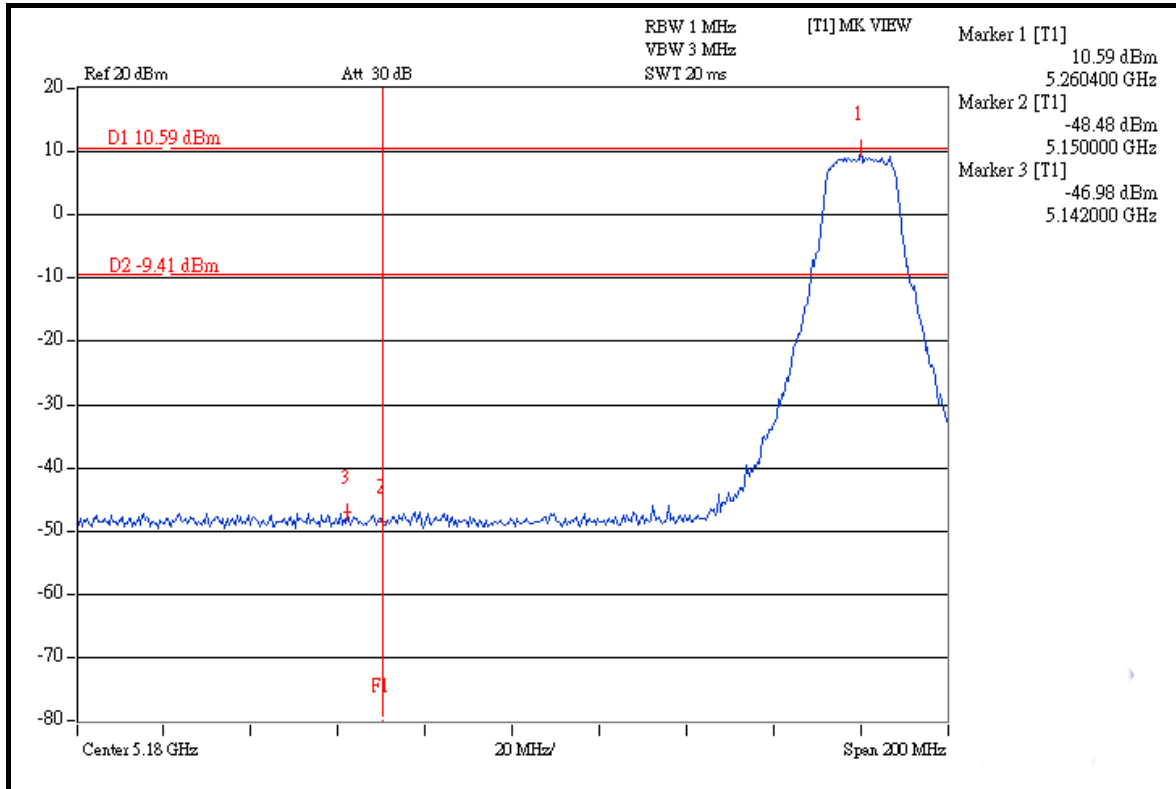



A D T

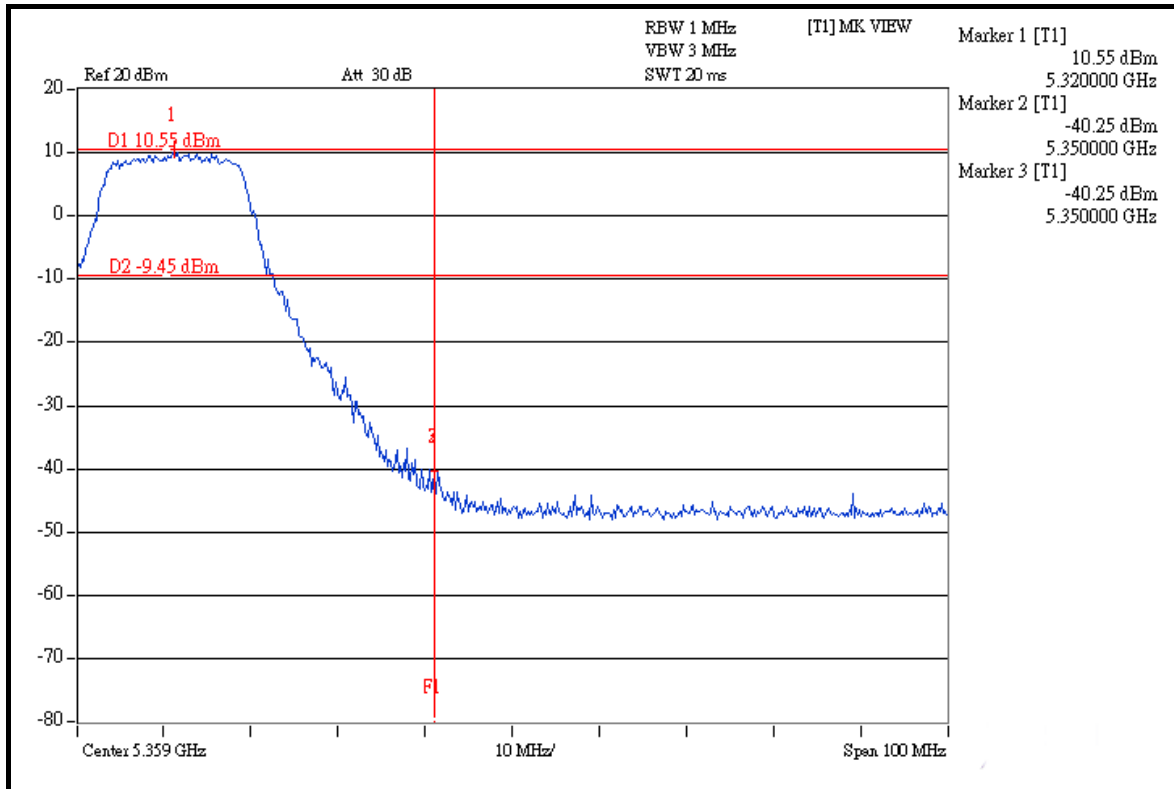
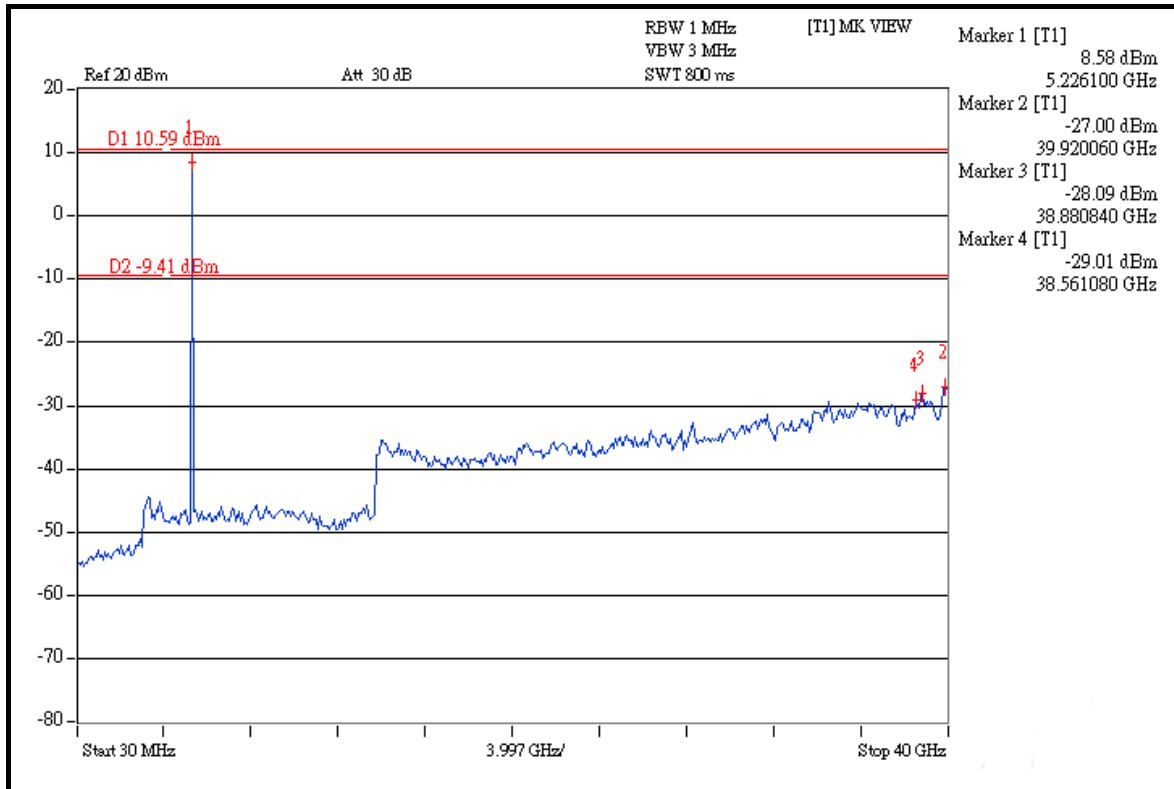



A D T

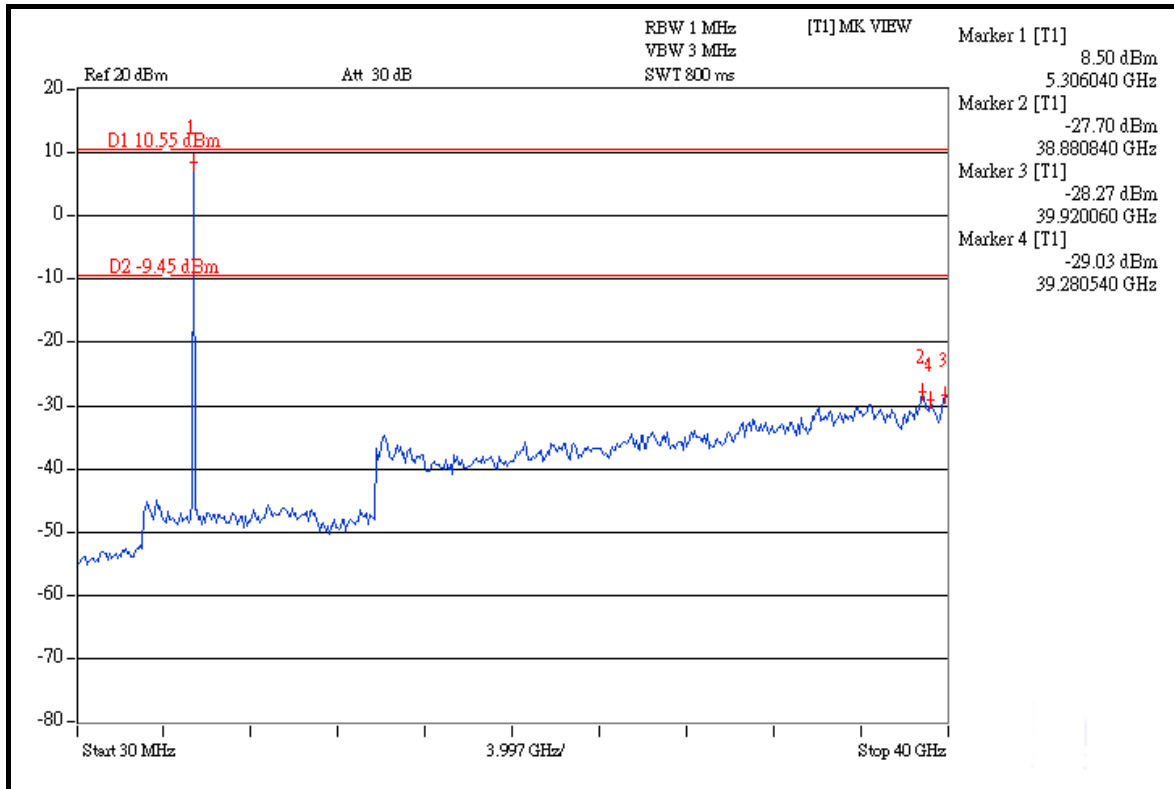
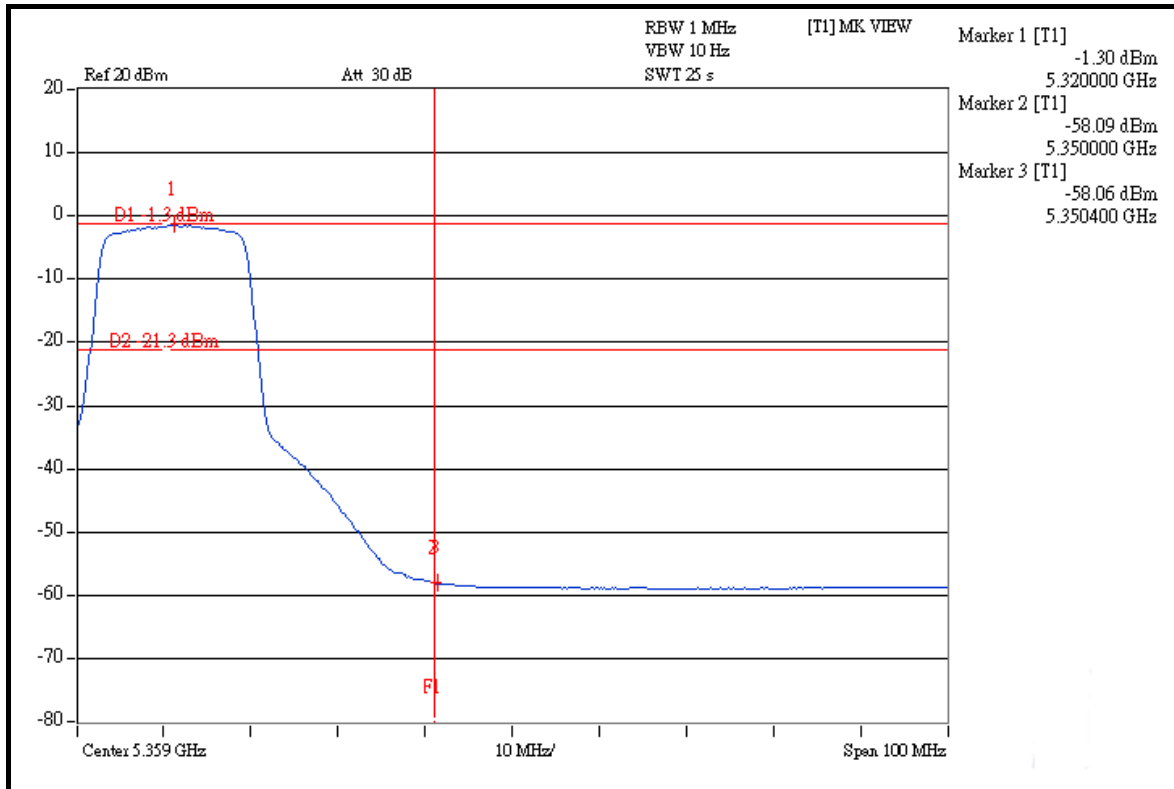

FOR 5470-5725MHz BAND: 802.11a OFDM MODULATION

Channel 100 (5500MHz)

The band edge emission plot (5.460GHz) on the next page shows 54.33dBc between carrier maximum power and local maximum emission in restrict band. The emission of carrier strength list in the test result of channel 100 is 111.32dBuV/m (Peak), so the maximum field strength in restrict band is $111.32 - 54.33 = 56.99$ dBuV/m which is under 74dBuV/m limit.

The band edge emission plot (5.460GHz) on the next page shows 56.40dBc between carrier maximum power and local maximum emission in restrict band. The emission of carrier strength list in the test result of channel 100 is 100.40dBuV/m (Average), so the maximum field strength in restrict band is $100.40 - 56.40 = 44.00$ dBuV/m which is under 54dBuV/m limit.

The band edge emission plot (5.470GHz) on the next page shows 52.42dBc between carrier maximum power and local maximum emission out of band emission. The emission of carrier strength list in the test result of channel 100 is 111.32dBuV/m (Peak), so the maximum field strength out of band emission is $111.32 - 52.42 = 58.90$ dBuV/m which is under 68.3dBuV/m limit.

Channel 140 (5700MHz)

The band edge emission plot on the next second page shows 41.26dBc between carrier maximum power and local maximum emission in restrict band. The emission of carrier strength list in the test result of channel 140 is 110.90dBuV/m (Peak), so the maximum field strength in restrict band is $110.90 - 43.73 = 67.17$ dBuV/m which is under 68.3dBuV/m limit.



A D T

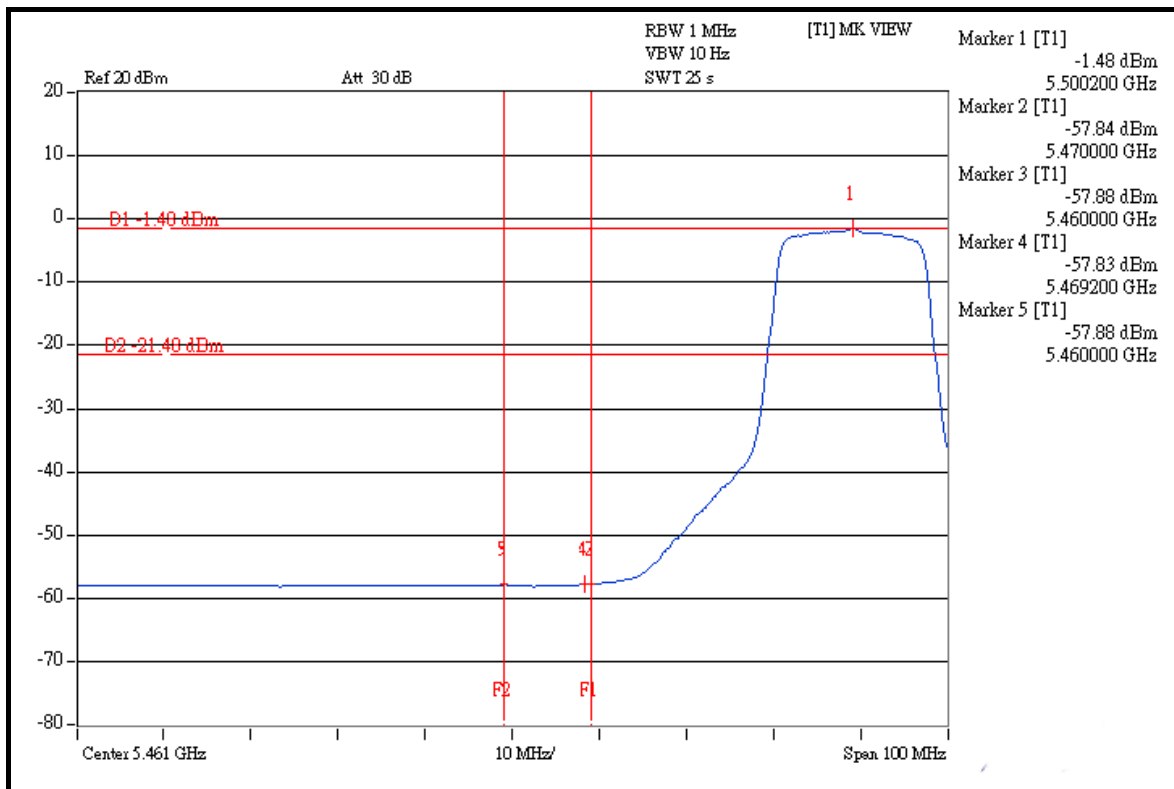
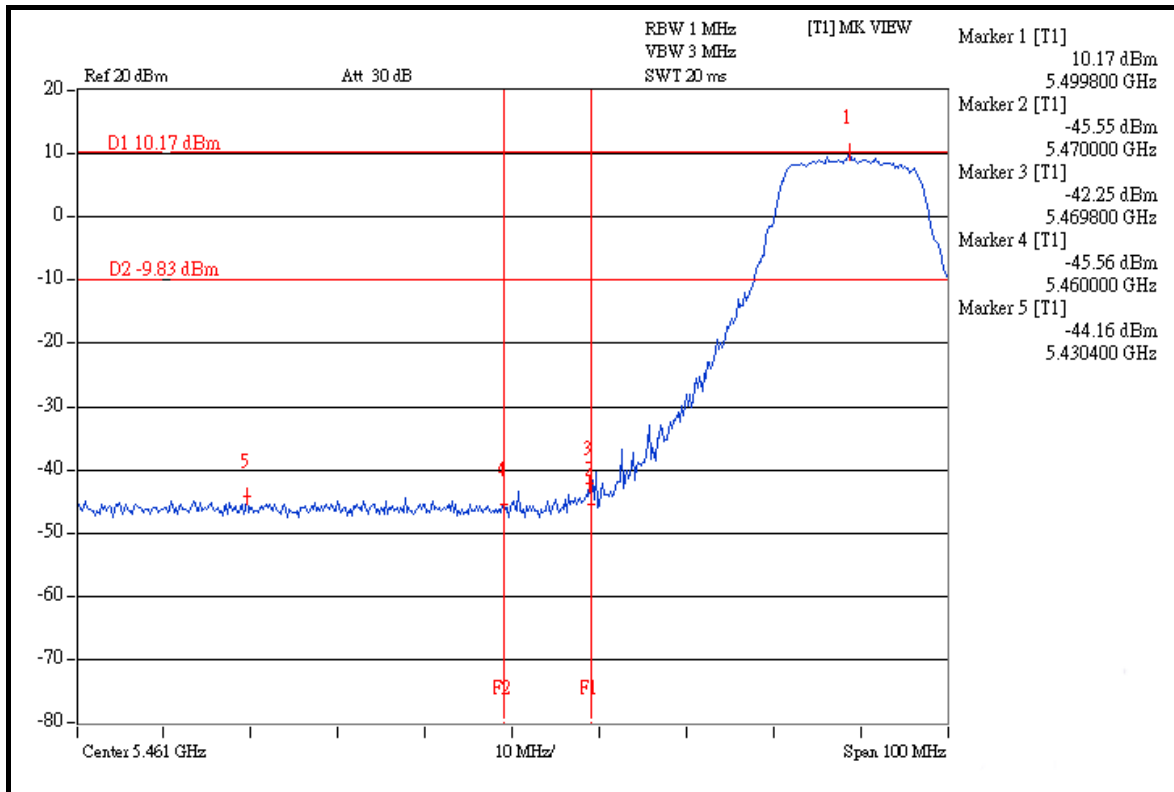



A D T

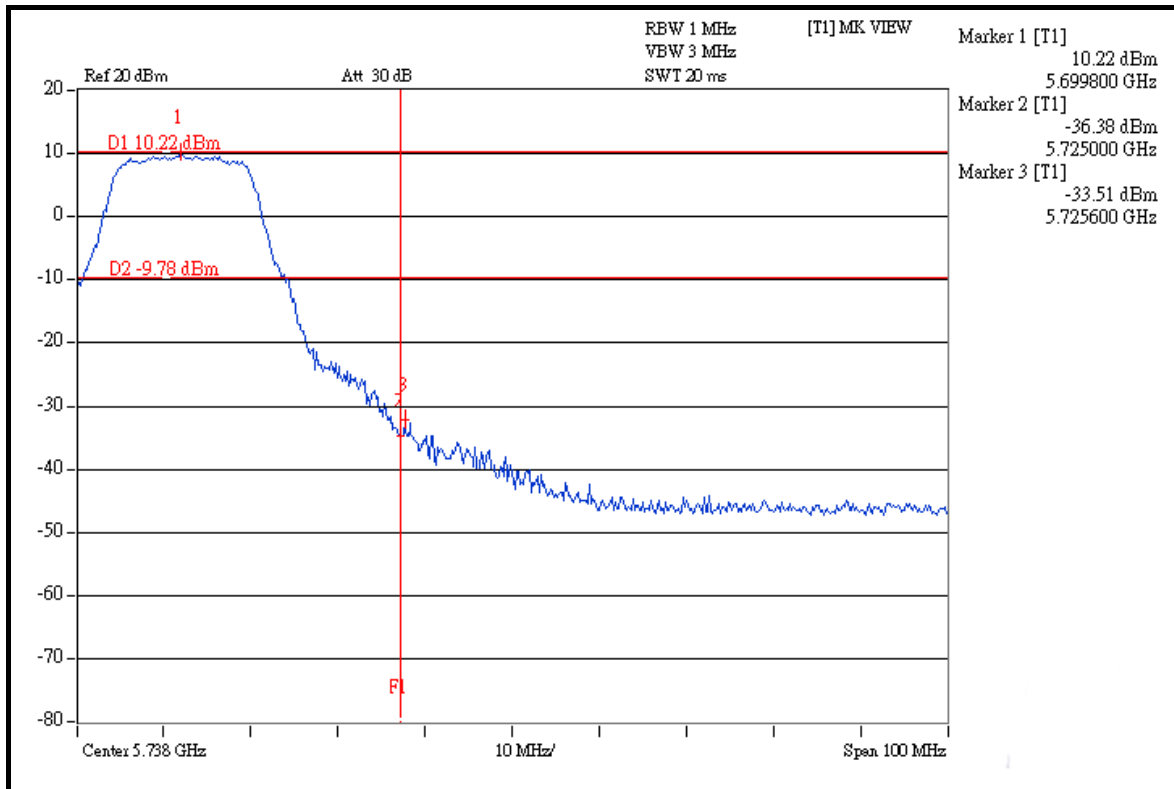
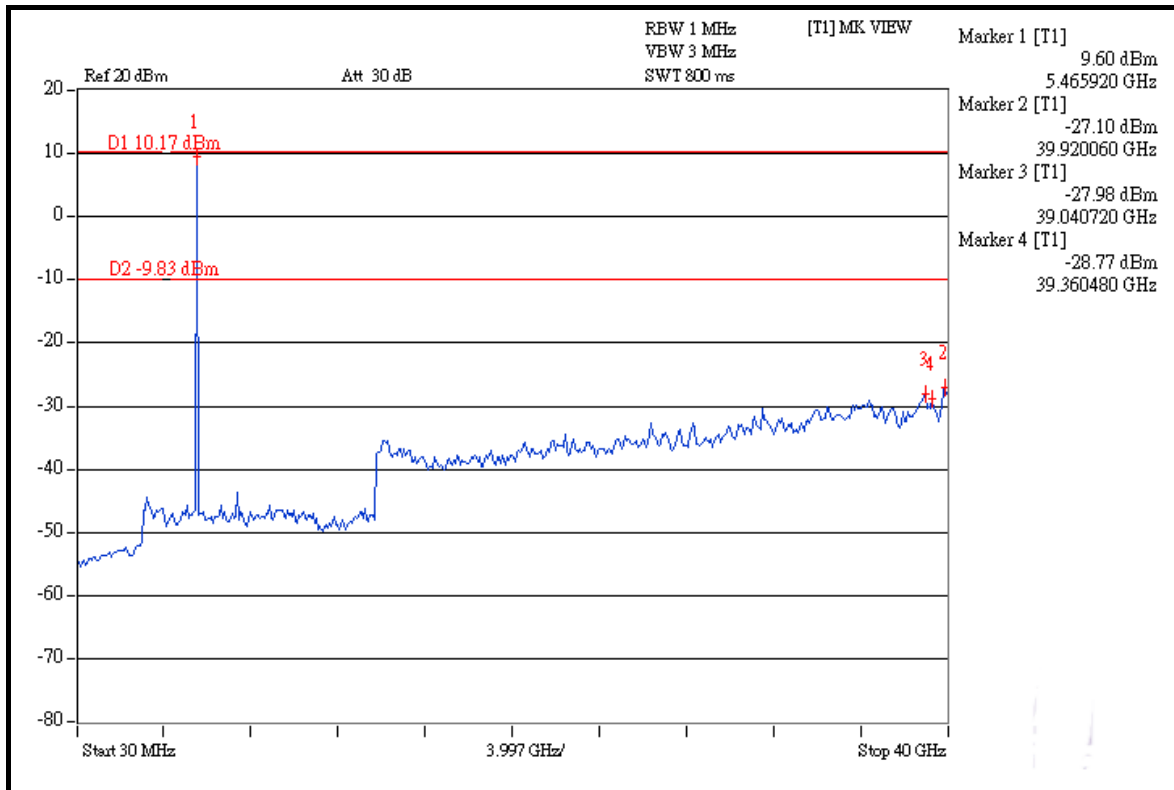



A D T

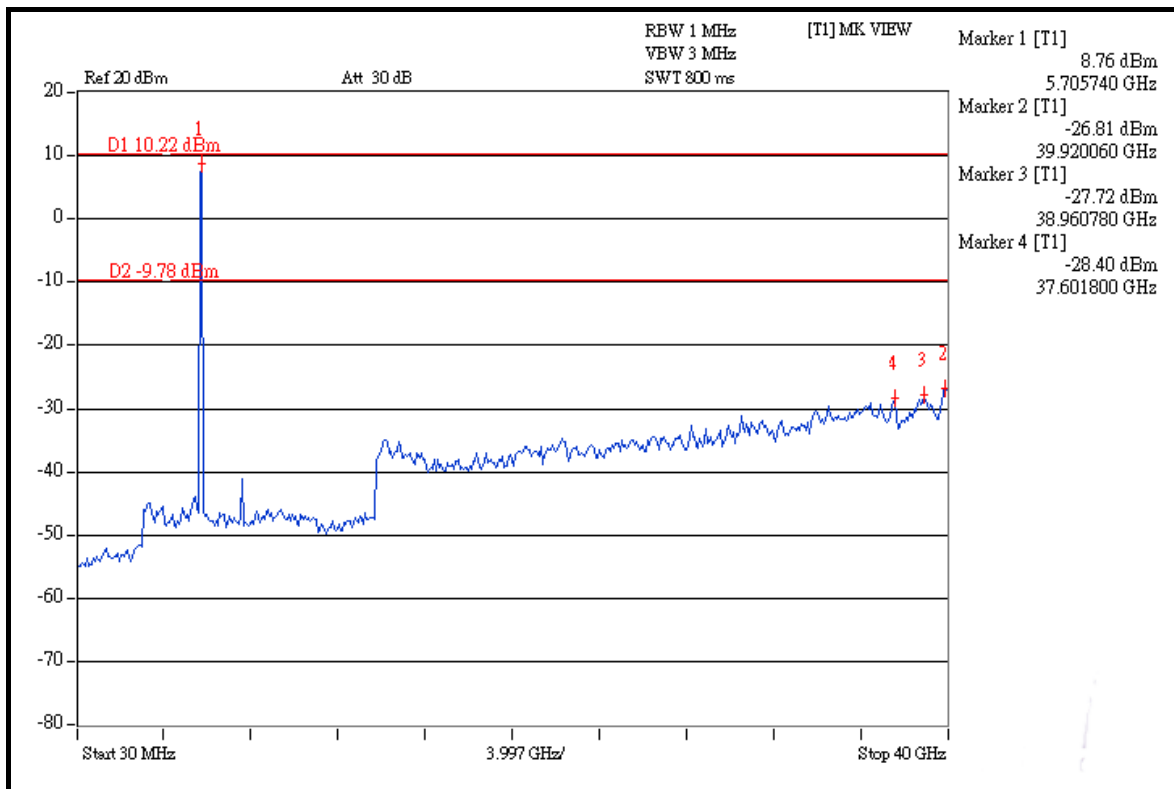
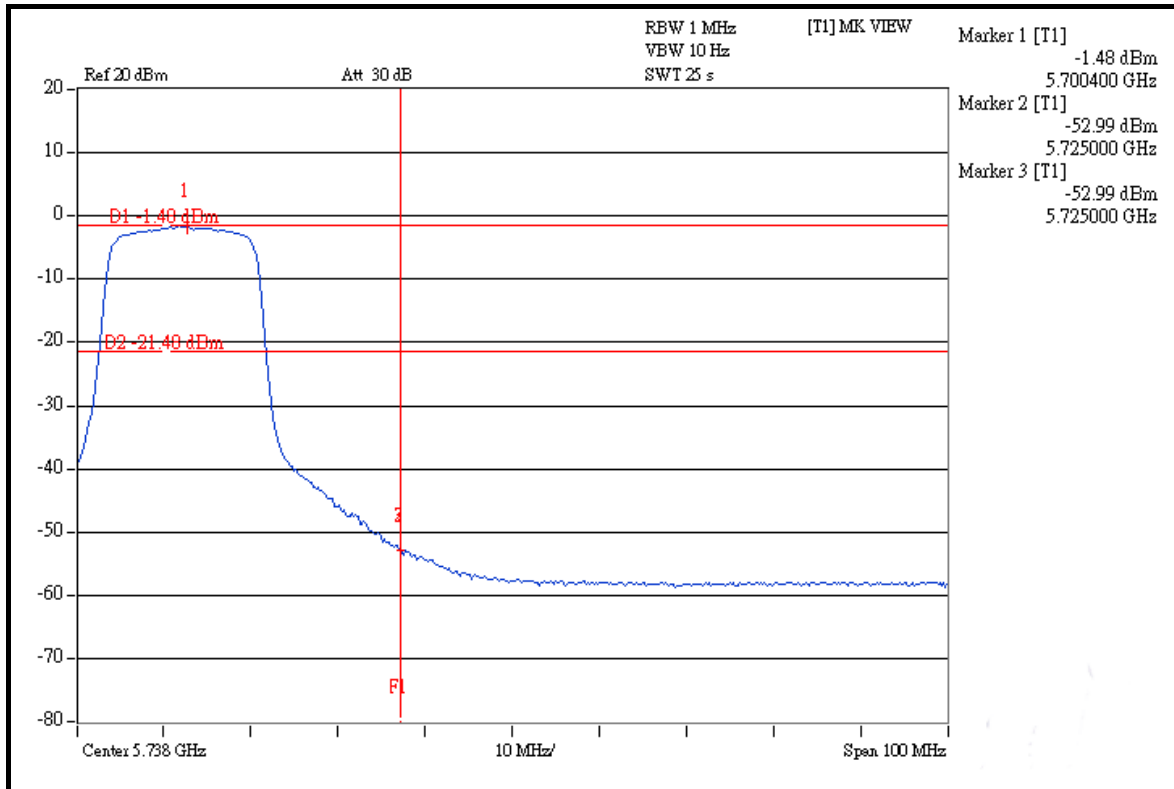

FOR 5250-5350MHz BAND: DRAFT 802.11n (20MHz) OFDM MODULATION

Channel 52 (5260MHz)

The band edge emission plot on the next page shows 53.18dBc between carrier maximum power and local maximum emission in restrict band. The emission of carrier strength list in the test result of channel 52 is 112.36dBuV/m (Peak), so the maximum field strength in restrict band is $112.36 - 53.18 = 59.18$ dBuV/m which is under 74dBuV/m limit.

The band edge emission plot on the next page shows 55.64dBc between carrier maximum power and local maximum emission in restrict band. The emission of carrier strength list in the test result of channel 52 is 101.76dBuV/m (Average), so the maximum field strength in restrict band is $101.76 - 55.64 = 46.12$ dBuV/m which is under 54dBuV/m limit.

Channel 64 (5320MHz)

The band edge emission plot on the next second page shows 51.17dBc between carrier maximum power and local maximum emission in restrict band. The emission of carrier strength list in the test result of channel 64 is 112.40dBuV/m (Peak), so the maximum field strength in restrict band is $112.40 - 51.17 = 61.23$ dBuV/m which is under 74dBuV/m limit.

The band edge emission plot on the next third page shows 54.98dBc between carrier maximum power and local maximum emission in restrict band. The emission of carrier strength list in the test result of channel 64 is 101.64dBuV/m (Average), so the maximum field strength in restrict band is $101.64 - 54.98 = 46.66$ dBuV/m which is under 54dBuV/m limit.



A D T

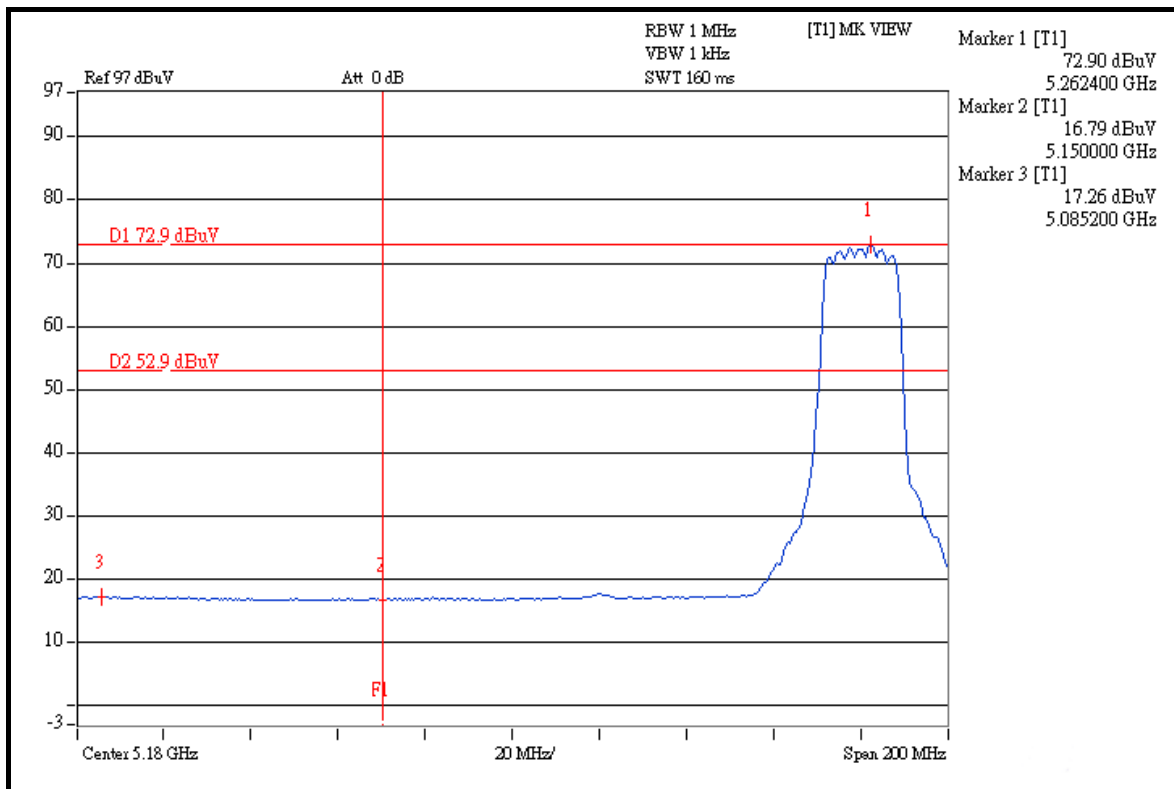
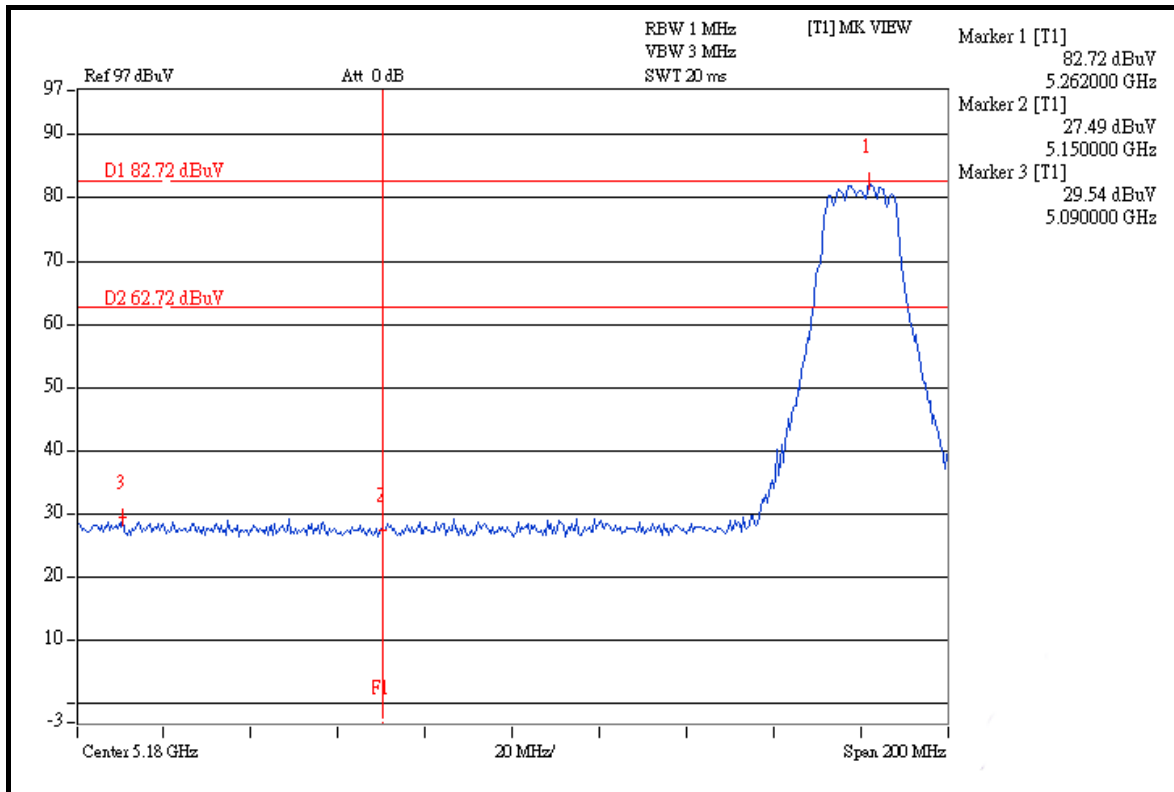



A D T

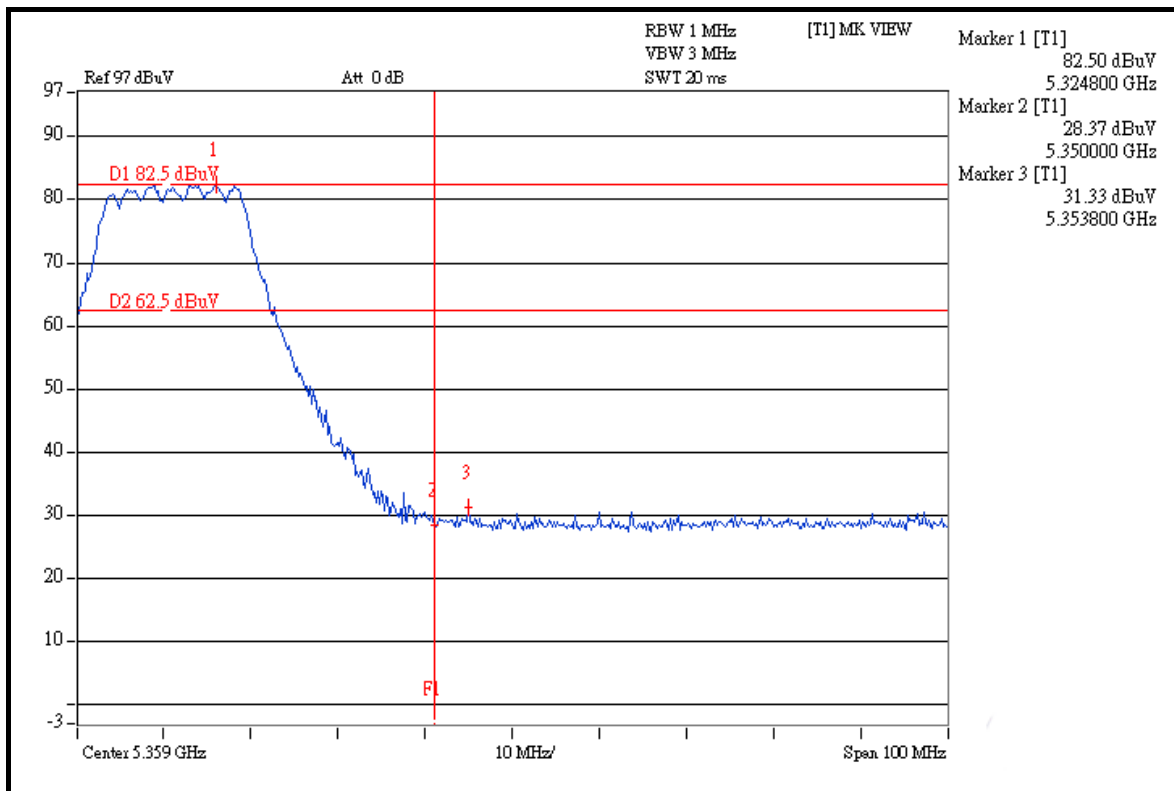
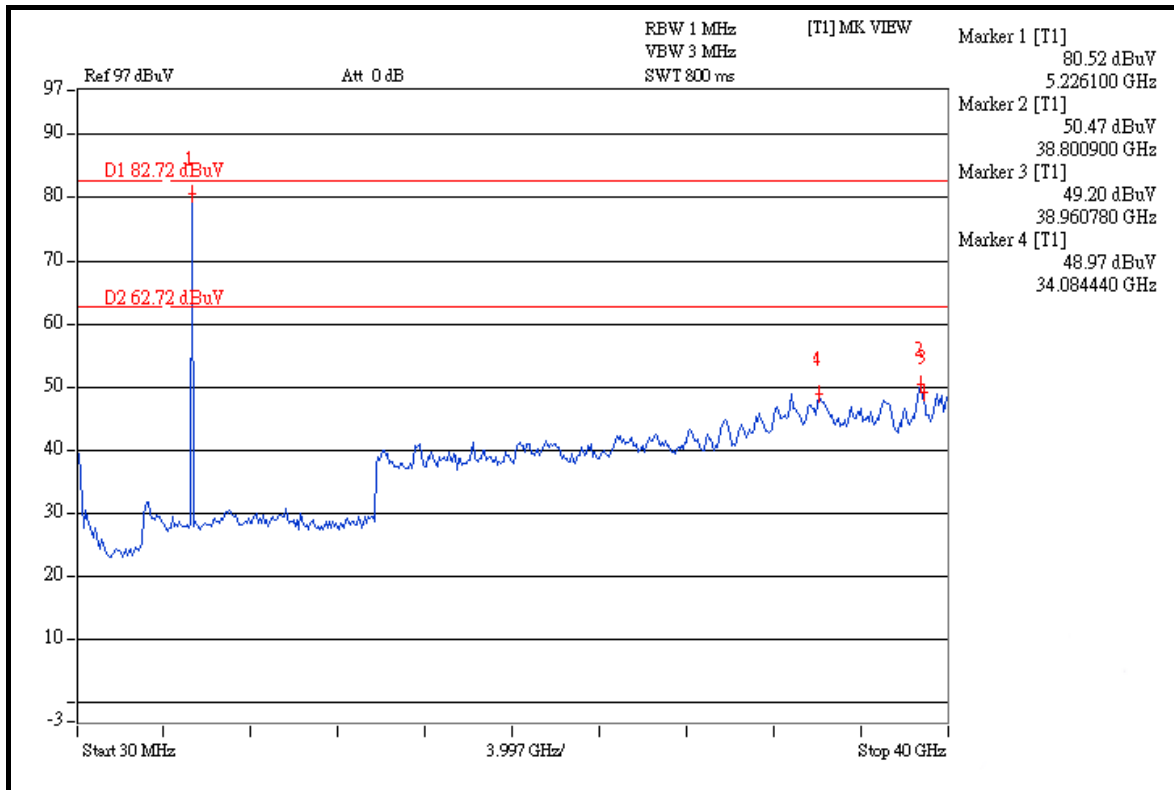



A D T

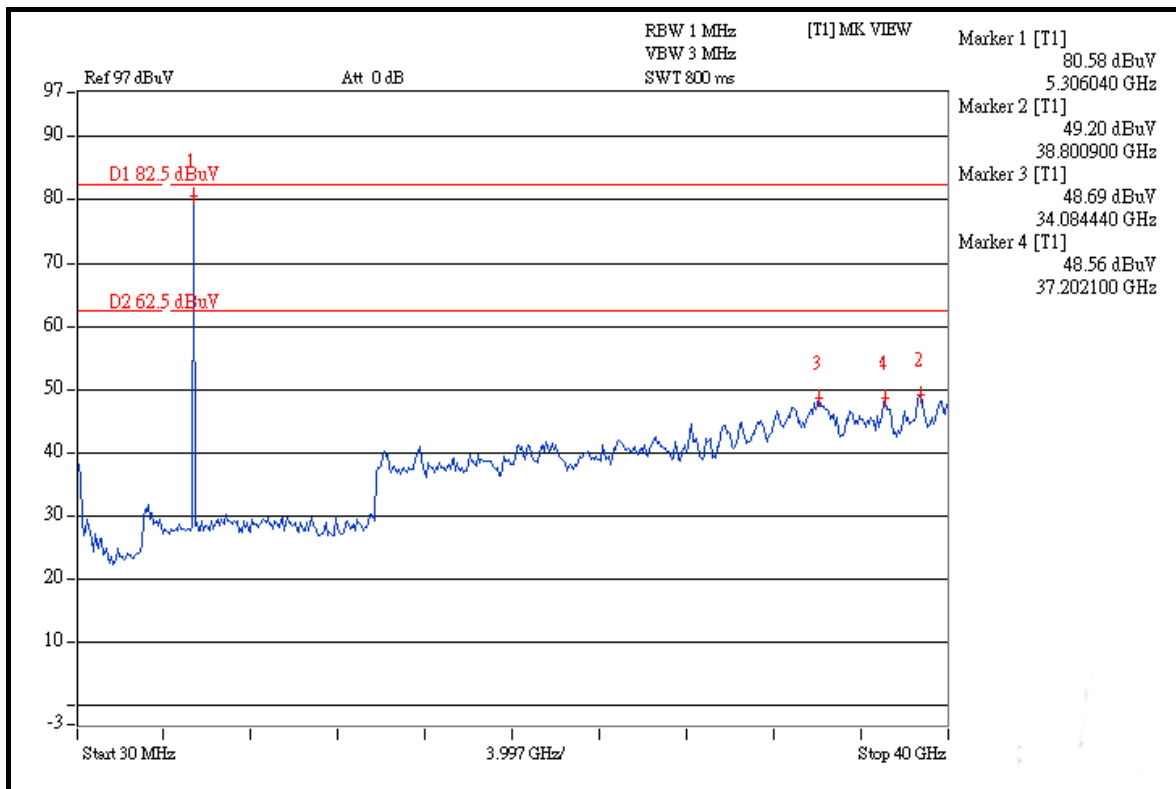
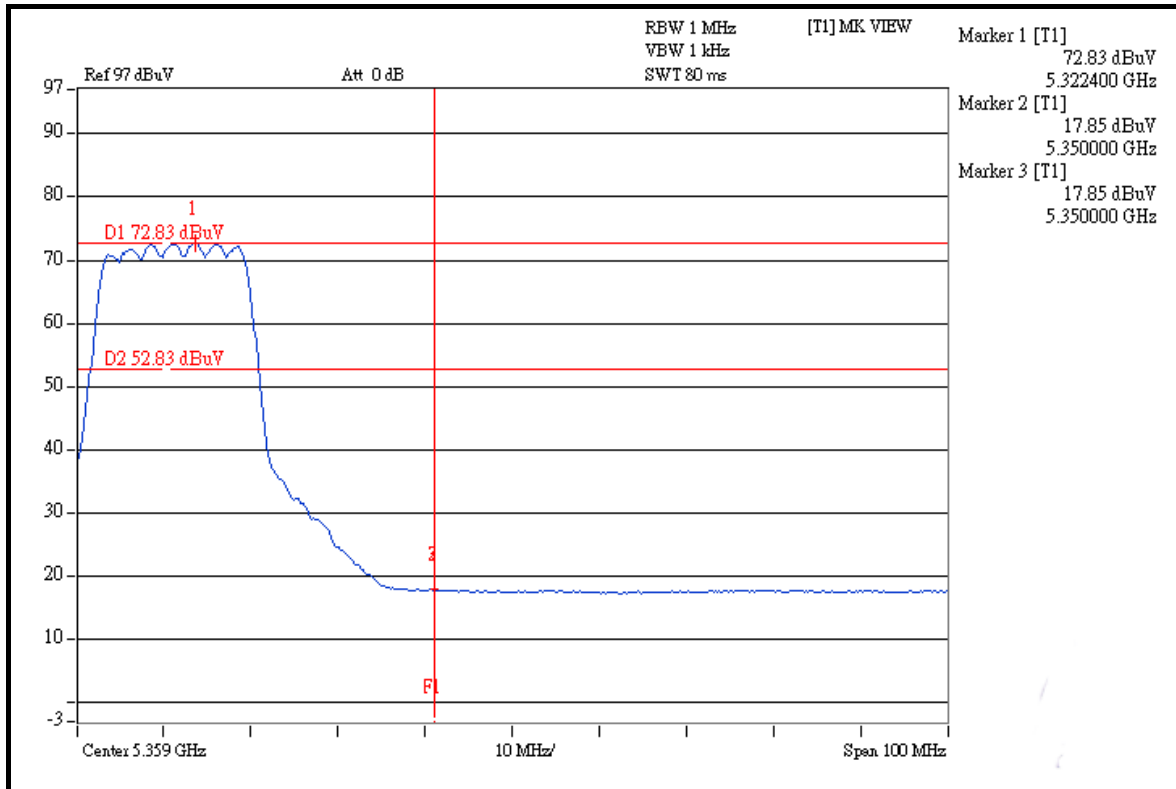

FOR 5470-5725MHz BAND: DRAFT 802.11n (20MHz) OFDM MODULATION

Channel 100 (5500MHz)

The band edge emission plot (5.460GHz) on the next page shows 51.19dBc between carrier maximum power and local maximum emission in restrict band. The emission of carrier strength list in the test result of channel 100 is 110.44dBuV/m (Peak), so the maximum field strength in restrict band is $110.44 - 51.19 = 59.25$ dBuV/m which is under 74dBuV/m limit.

The band edge emission plot (5.460GHz) on the next page shows 54.10dBc between carrier maximum power and local maximum emission in restrict band. The emission of carrier strength list in the test result of channel 100 is 99.80dBuV/m (Average), so the maximum field strength in restrict band is $99.80 - 54.10 = 45.70$ dBuV/m which is under 54dBuV/m limit.

The band edge emission plot (5.470GHz) on the next page shows 51.43dBc between carrier maximum power and local maximum emission out of band emission. The emission of carrier strength list in the test result of channel 100 is 110.44dBuV/m (Peak), so the maximum field strength out of band emission is $110.44 - 51.43 = 59.01$ dBuV/m which is under 68.3dBuV/m limit.

Channel 140 (5700MHz)

The band edge emission plot on the next second page shows 46.63dBc between carrier maximum power and local maximum emission in restrict band. The emission of carrier strength list in the test result of channel 140 is 110.75dBuV/m (Peak), so the maximum field strength in restrict band is $110.75 - 46.63 = 64.12$ dBuV/m which is under 68.3dBuV/m limit.



A D T

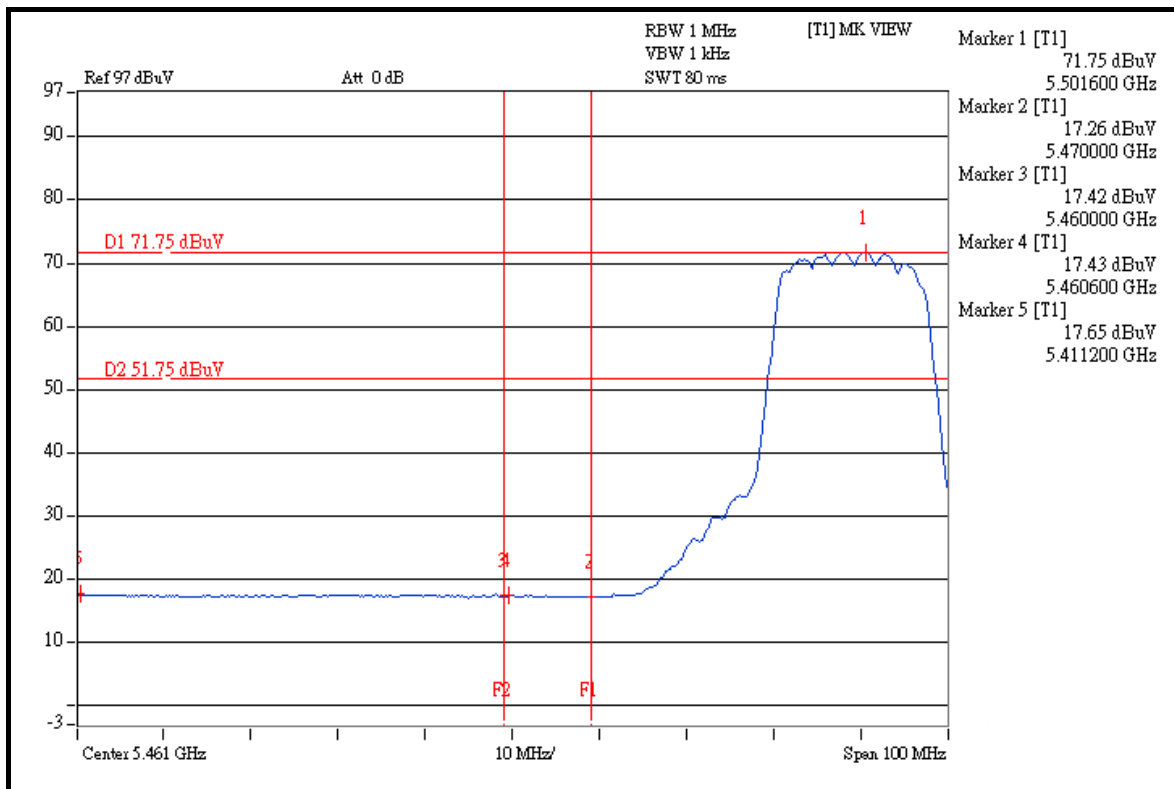
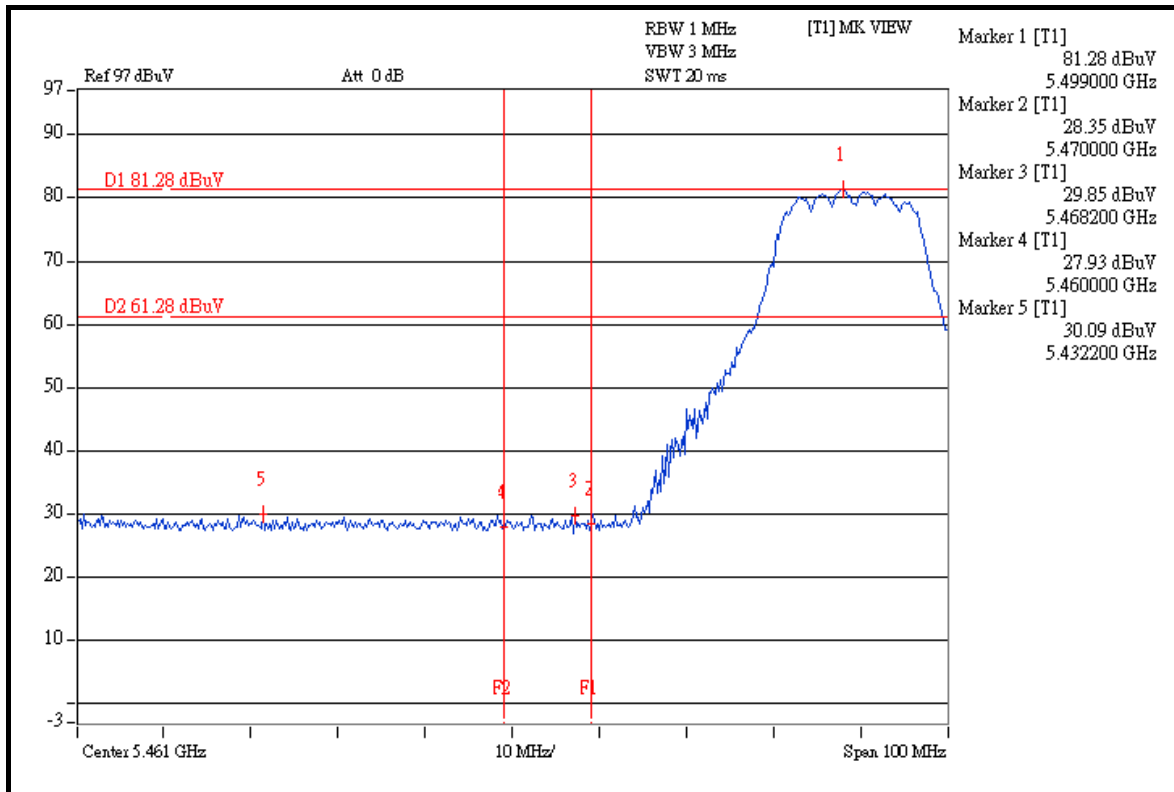



A D T

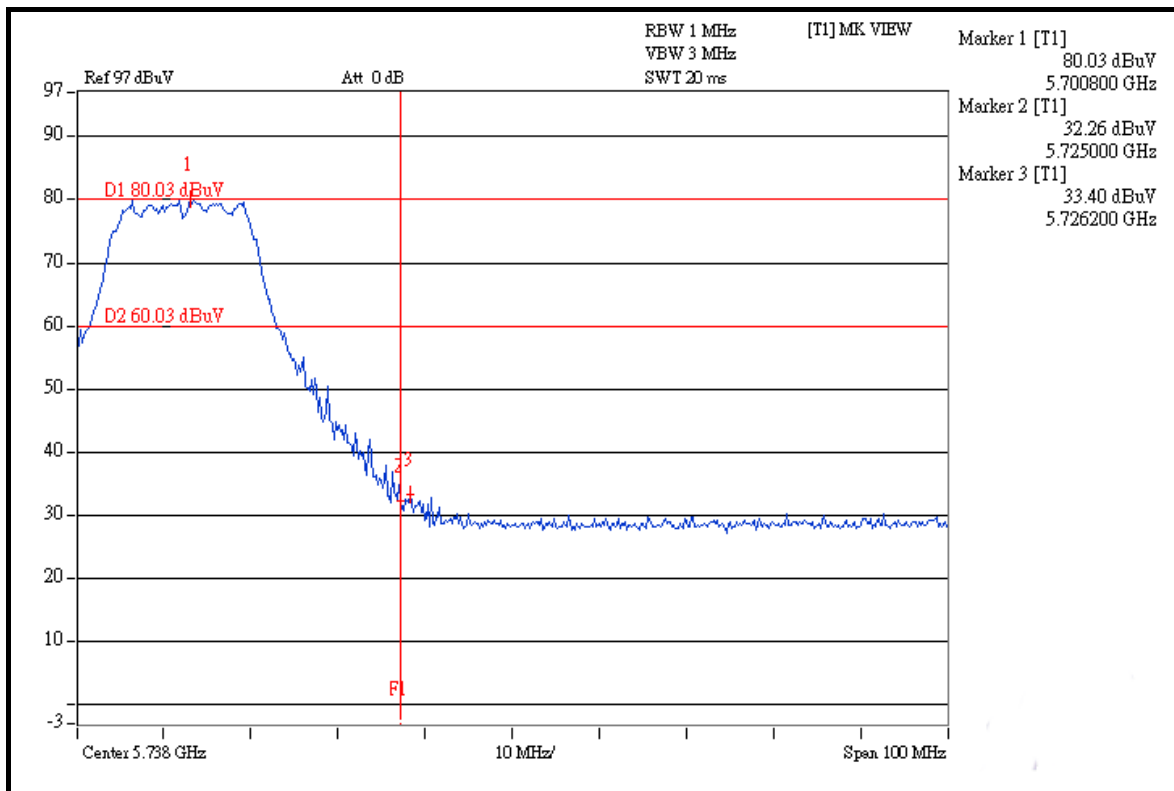
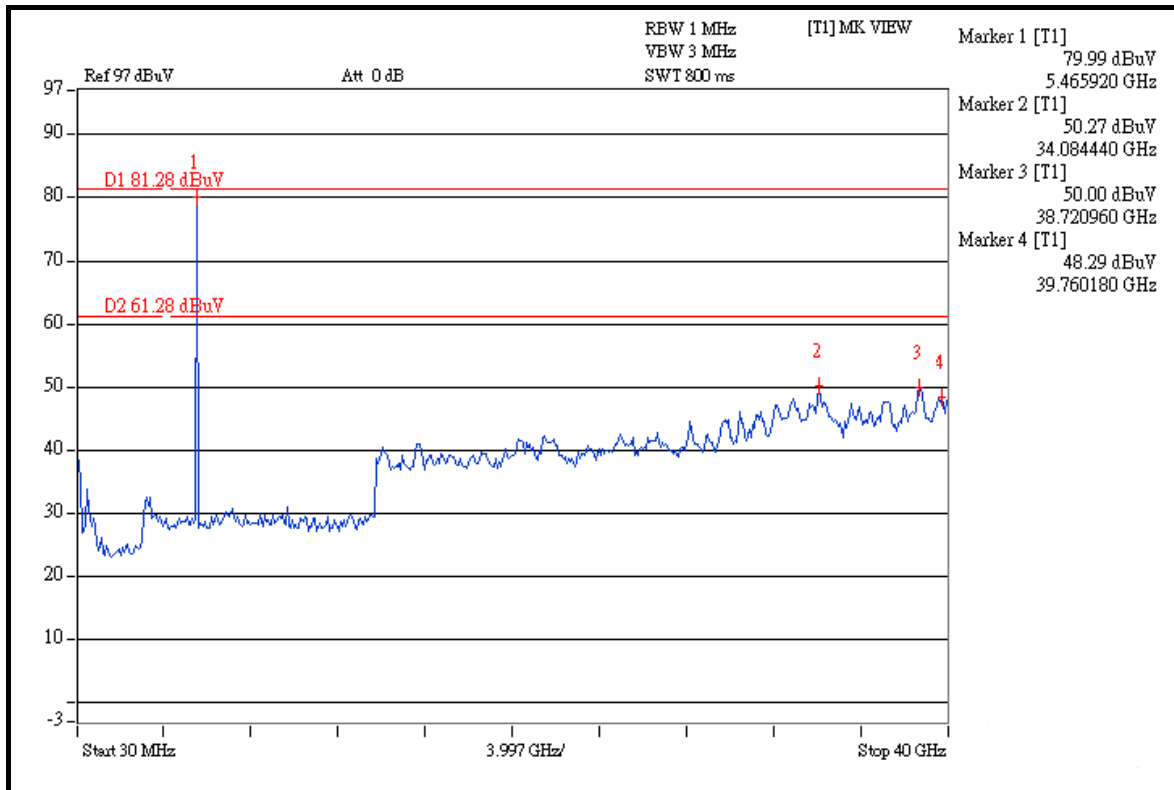



A D T

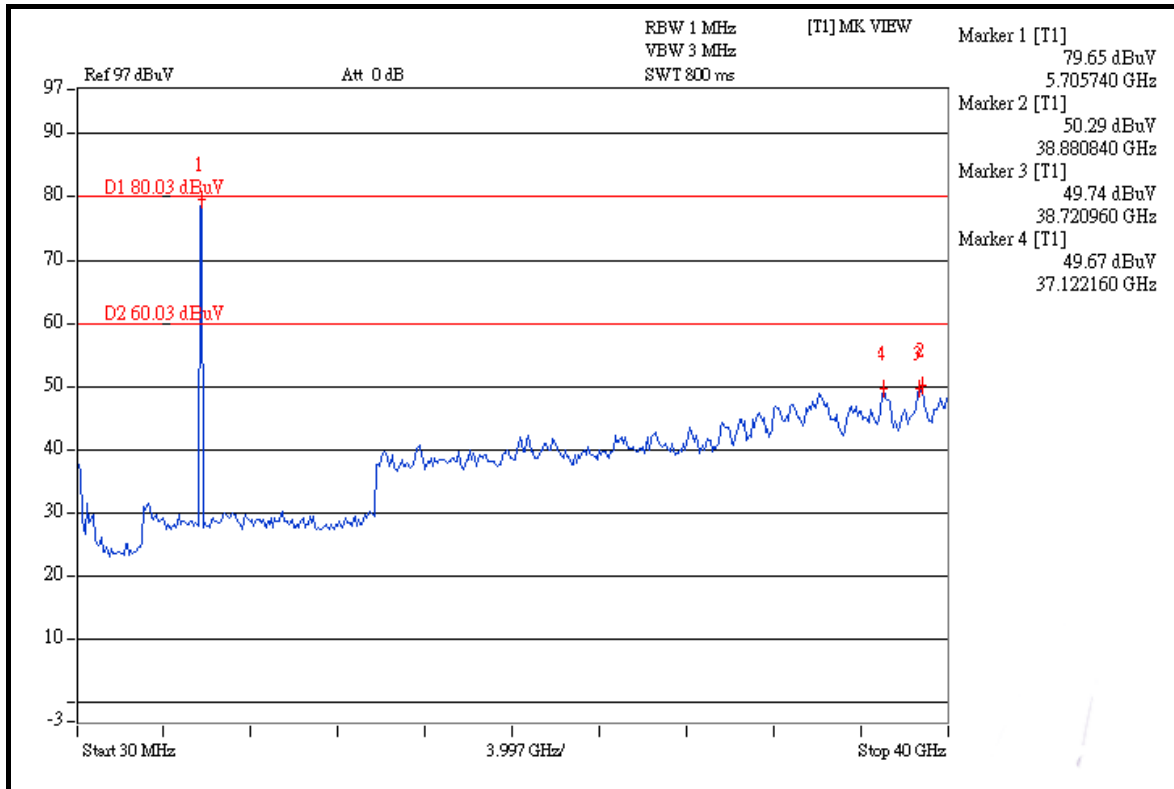
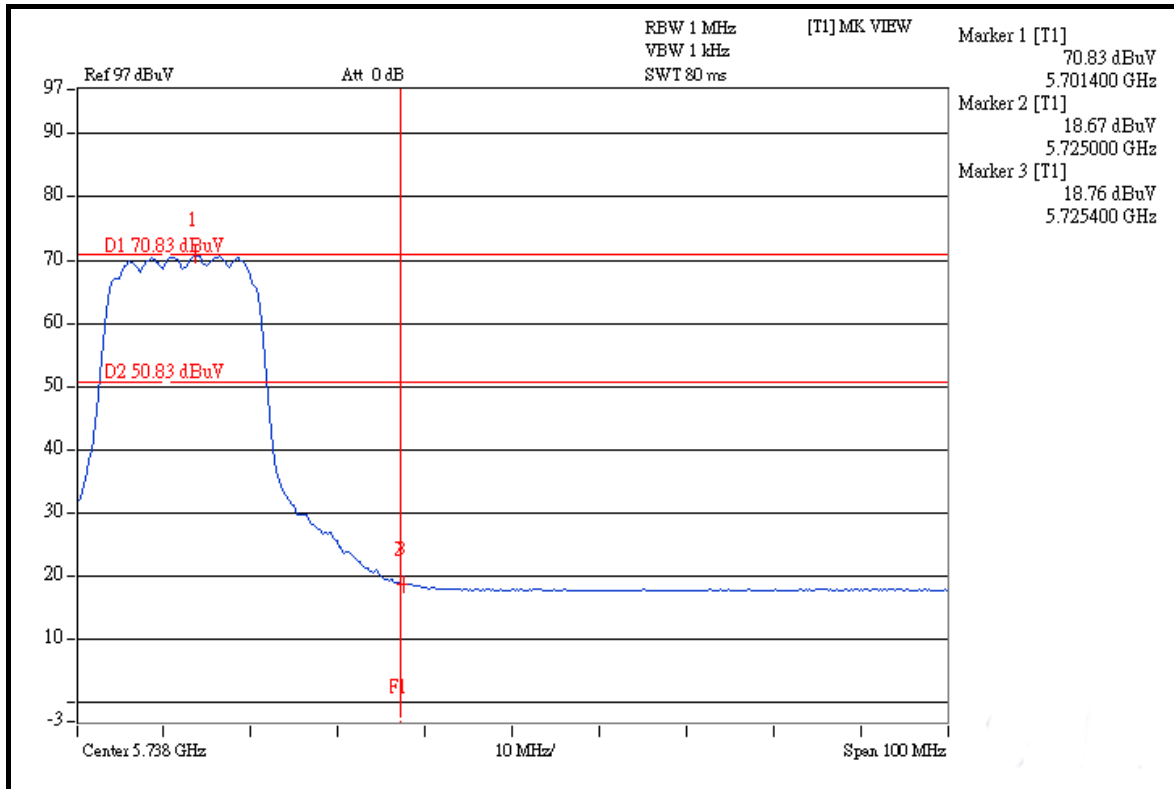

FOR 5250-5350MHz BAND: DRAFT 802.11n (40MHz) OFDM MODULATION

Channel 54 (5270MHz)

The band edge emission plot on the next page shows 51.22dBc between carrier maximum power and local maximum emission in restrict band. The emission of carrier strength list in the test result of channel 54 is 106.76dBuV/m (Peak), so the maximum field strength in restrict band is $106.76 - 51.22 = 55.54$ dBuV/m which is under 74dBuV/m limit.

The band edge emission plot on the next page shows 53.79dBc between carrier maximum power and local maximum emission in restrict band. The emission of carrier strength list in the test result of channel 54 is 95.69dBuV/m (Average), so the maximum field strength in restrict band is $95.69 - 53.79 = 41.90$ dBuV/m which is under 54dBuV/m limit.

Channel 62 (5310MHz)

The band edge emission plot on the next second page shows 43.21dBc between carrier maximum power and local maximum emission in restrict band. The emission of carrier strength list in the test result of channel 62 is 107.17dBuV/m (Peak), so the maximum field strength in restrict band is $107.17 - 43.21 = 63.96$ dBuV/m which is under 74dBuV/m limit.

The band edge emission plot on the next third page shows 46.23dBc between carrier maximum power and local maximum emission in restrict band. The emission of carrier strength list in the test result of channel 62 is 96.06dBuV/m (Average), so the maximum field strength in restrict band is $96.06 - 46.23 = 49.83$ dBuV/m which is under 54dBuV/m limit.



A D T

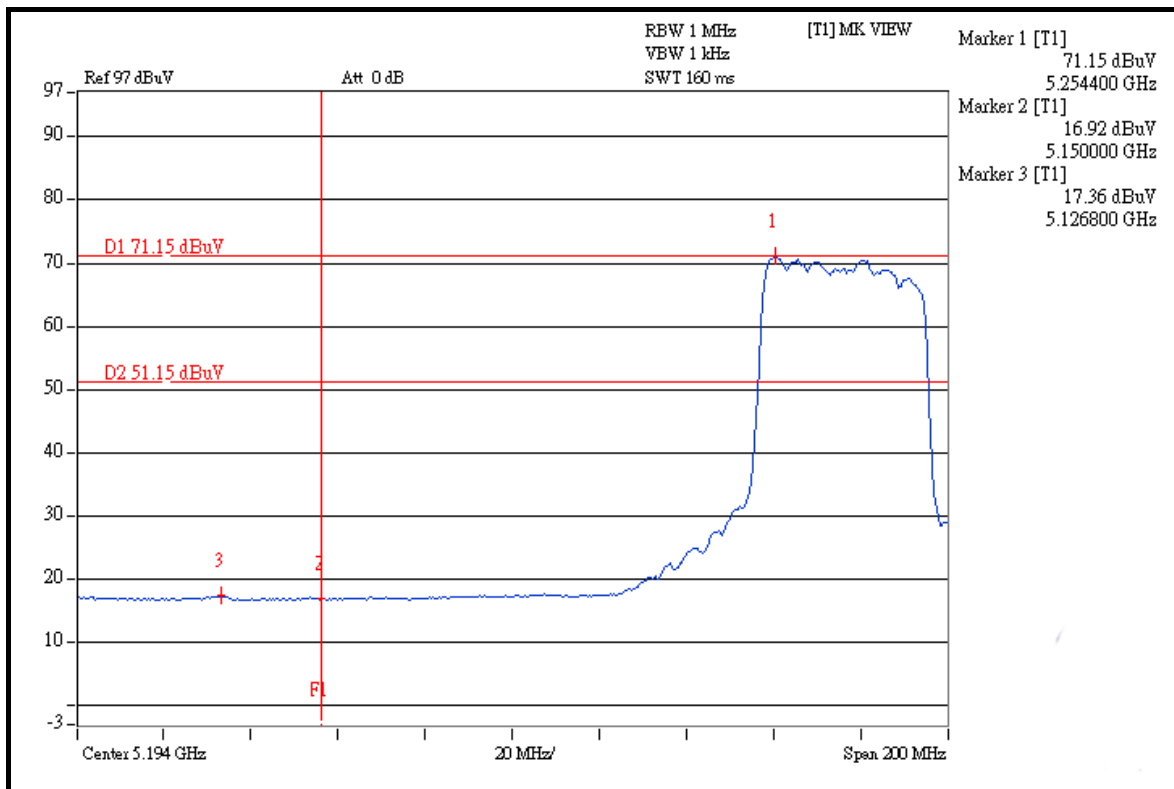
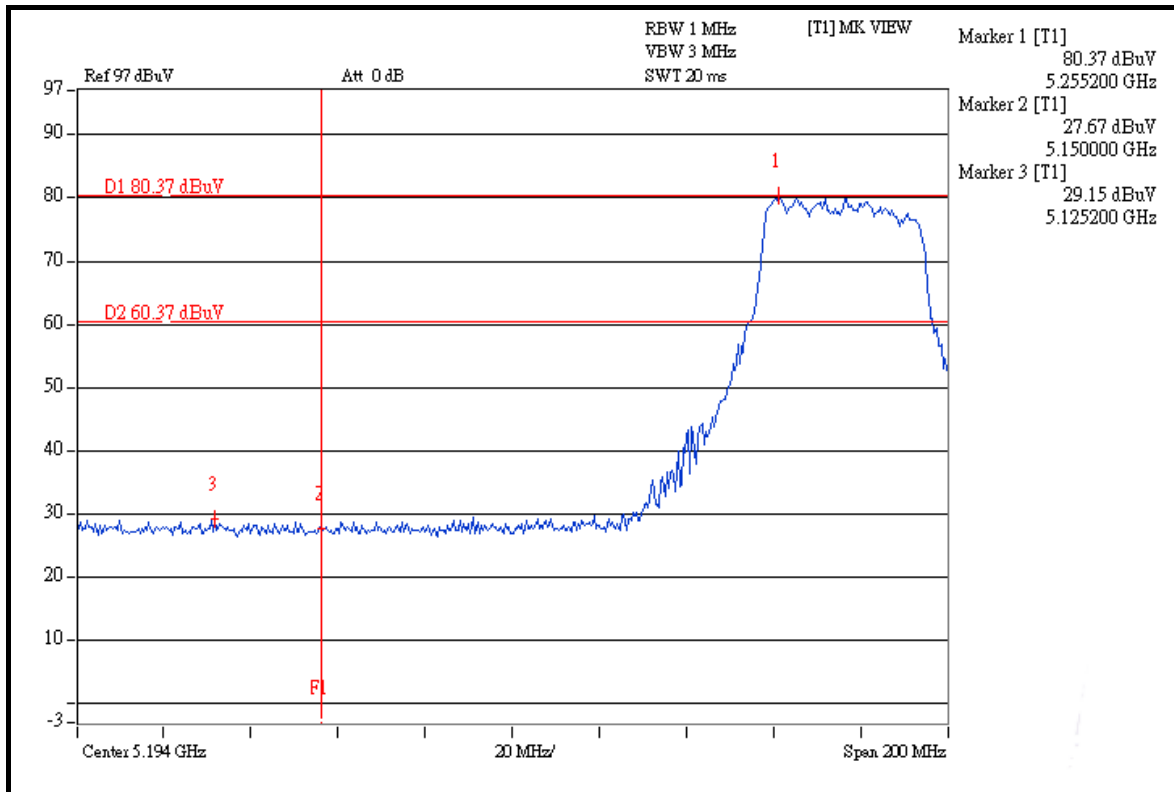



A D T

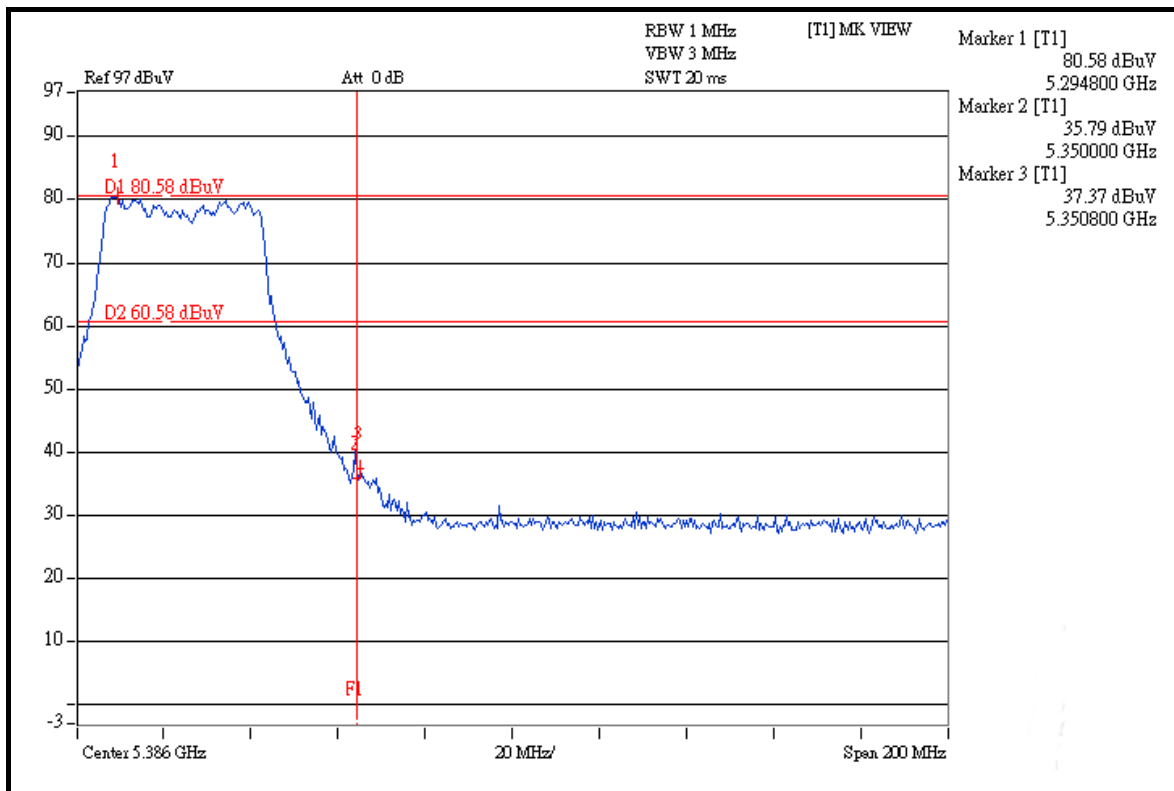
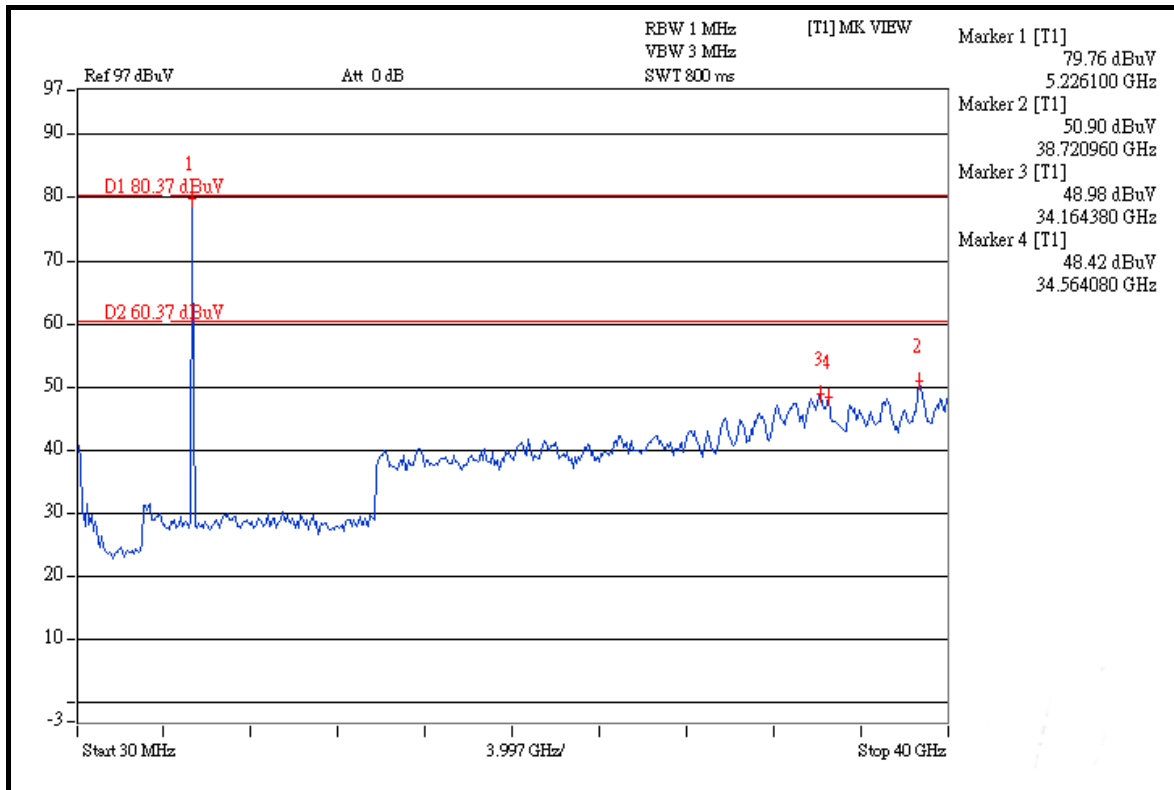



A D T

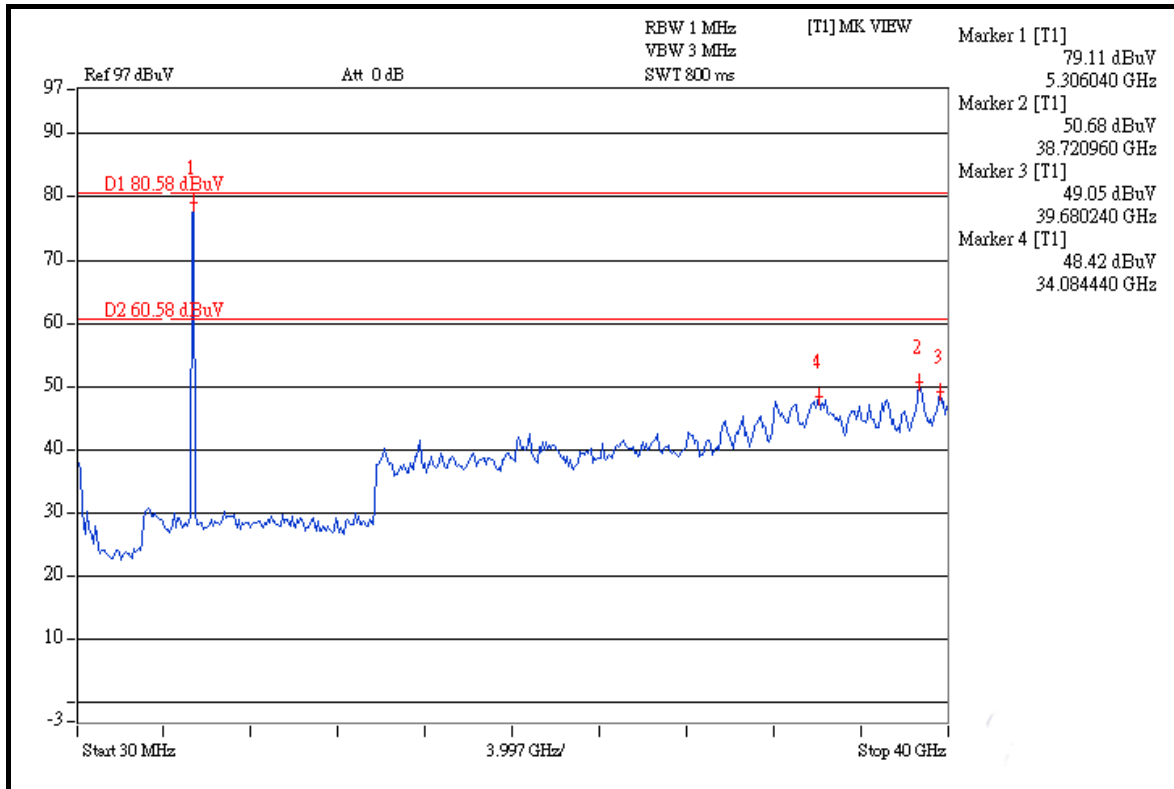
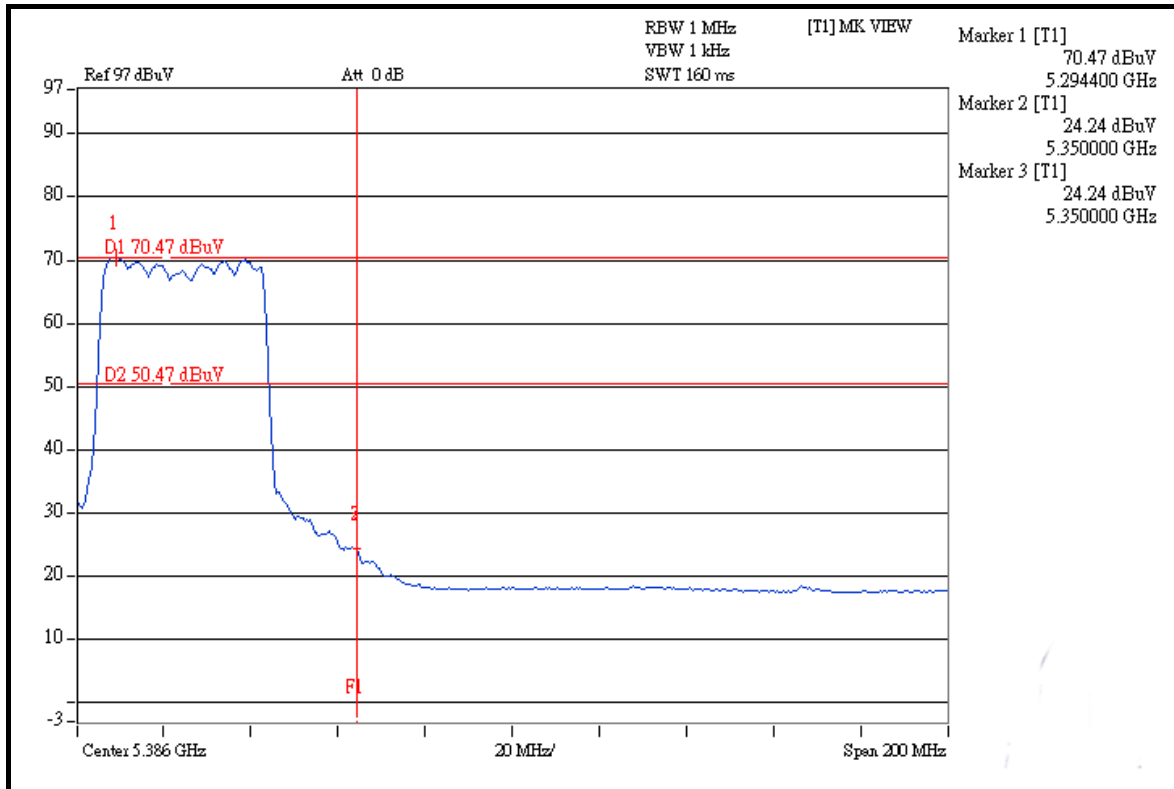

FOR 5470-5725MHz BAND: DRAFT 802.11n (40MHz) OFDM MODULATION

Channel 102 (5510MHz)

The band edge emission plot (5.460GHz) on the next page shows 50.10dBc between carrier maximum power and local maximum emission in restrict band. The emission of carrier strength list in the test result of channel 102 is 106.94dBuV/m (Peak), so the maximum field strength in restrict band is $106.94 - 50.10 = 56.84$ dBuV/m which is under 74dBuV/m limit.

The band edge emission plot (5.460GHz) on the next page shows 51.74dBc between carrier maximum power and local maximum emission in restrict band. The emission of carrier strength list in the test result of channel 102 is 96.99dBuV/m (Average), so the maximum field strength in restrict band is $96.99 - 51.74 = 45.25$ dBuV/m which is under 54dBuV/m limit.

The band edge emission plot (5.470GHz) on the next page shows 40.08dBc between carrier maximum power and local maximum emission out of band emission. The emission of carrier strength list in the test result of channel 102 is 106.94dBuV/m (Peak), so the maximum field strength out of band emission is $106.94 - 40.08 = 66.86$ dBuV/m which is under 68.3dBuV/m limit.

Channel 134 (5670MHz)

The band edge emission plot on the next second page shows 45.98dBc between carrier maximum power and local maximum emission in restrict band. The emission of carrier strength list in the test result of channel 134 is 107.44dBuV/m (Peak), so the maximum field strength in restrict band is $107.44 - 45.98 = 61.46$ dBuV/m which is under 68.3dBuV/m limit.



A D T

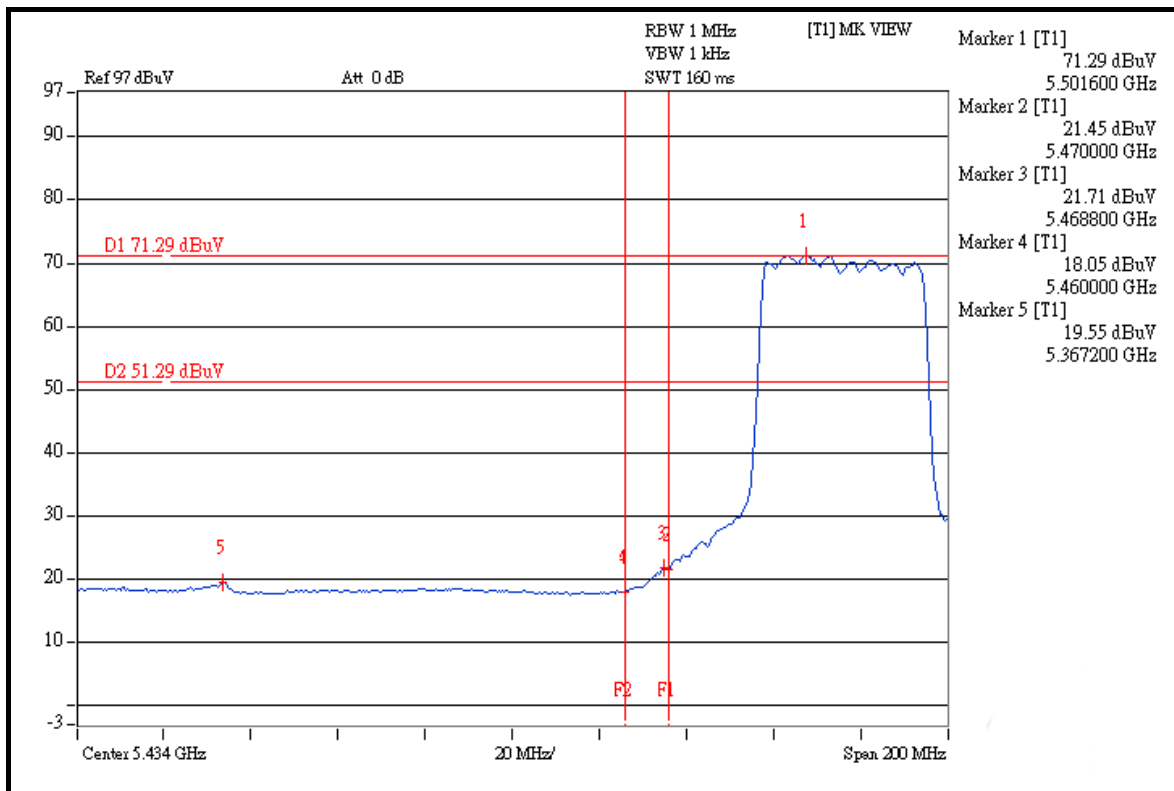
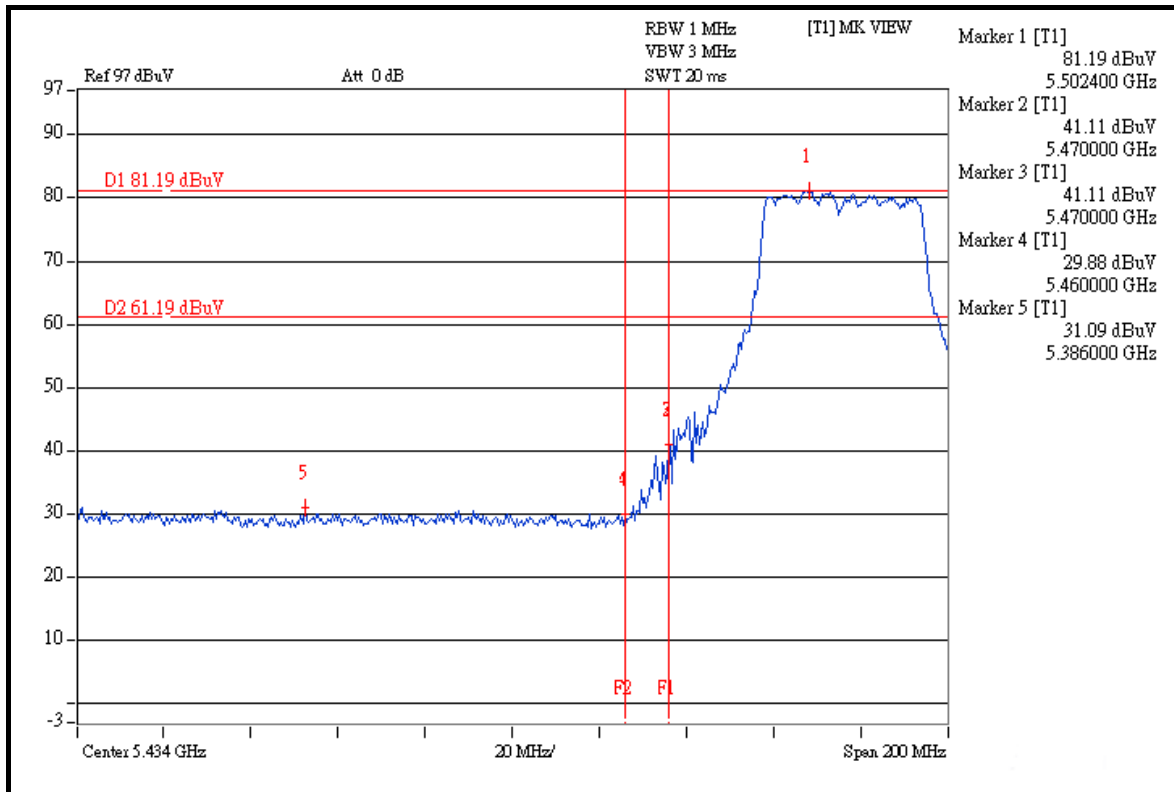



A D T

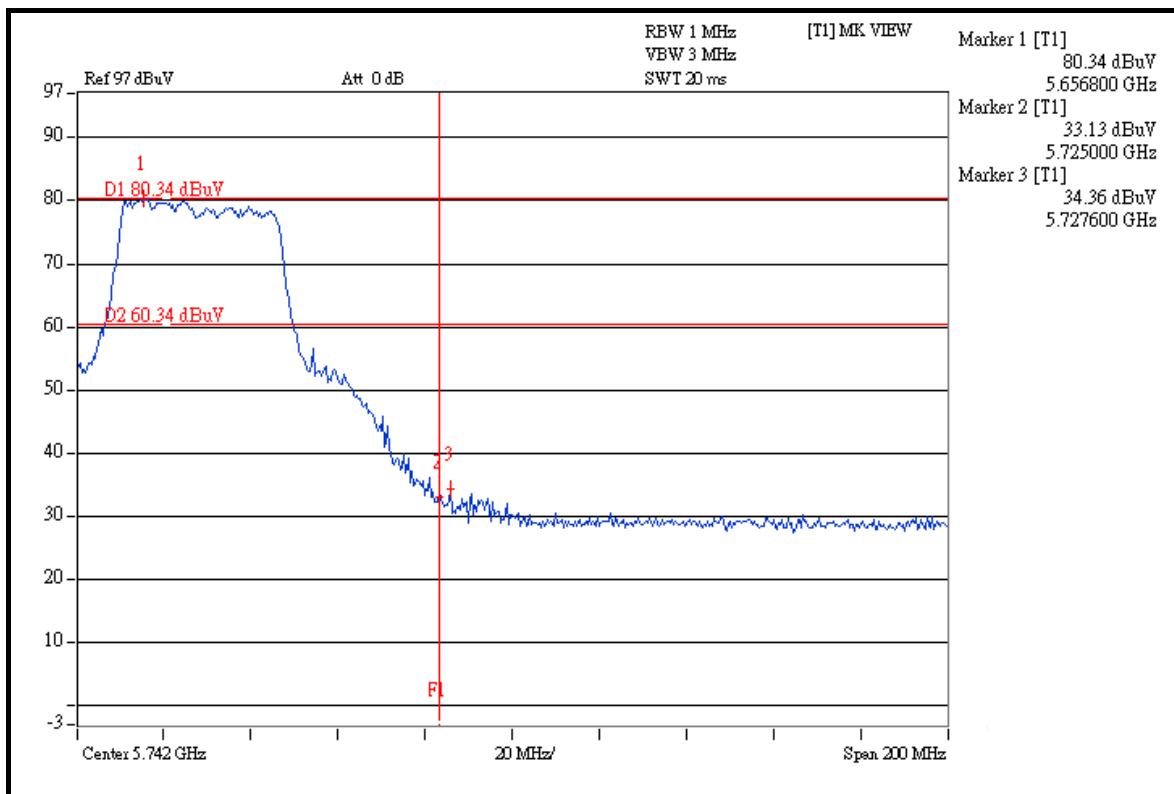
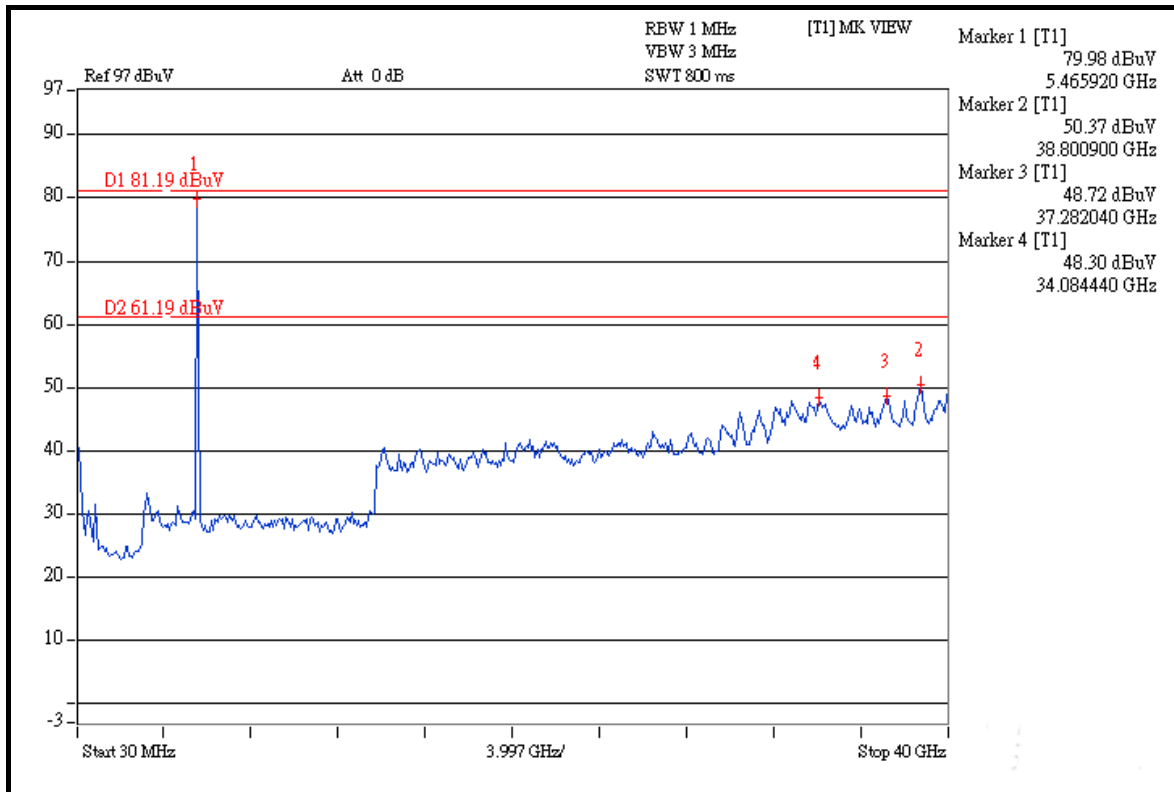



A D T

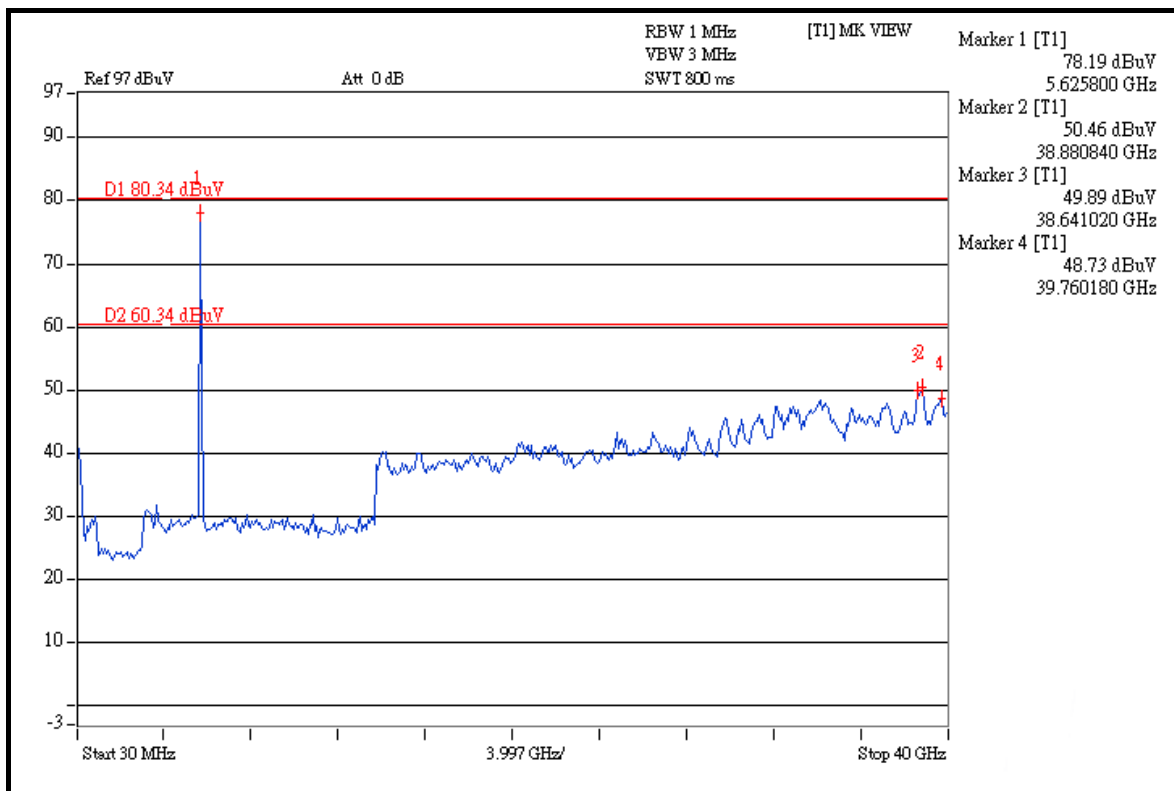
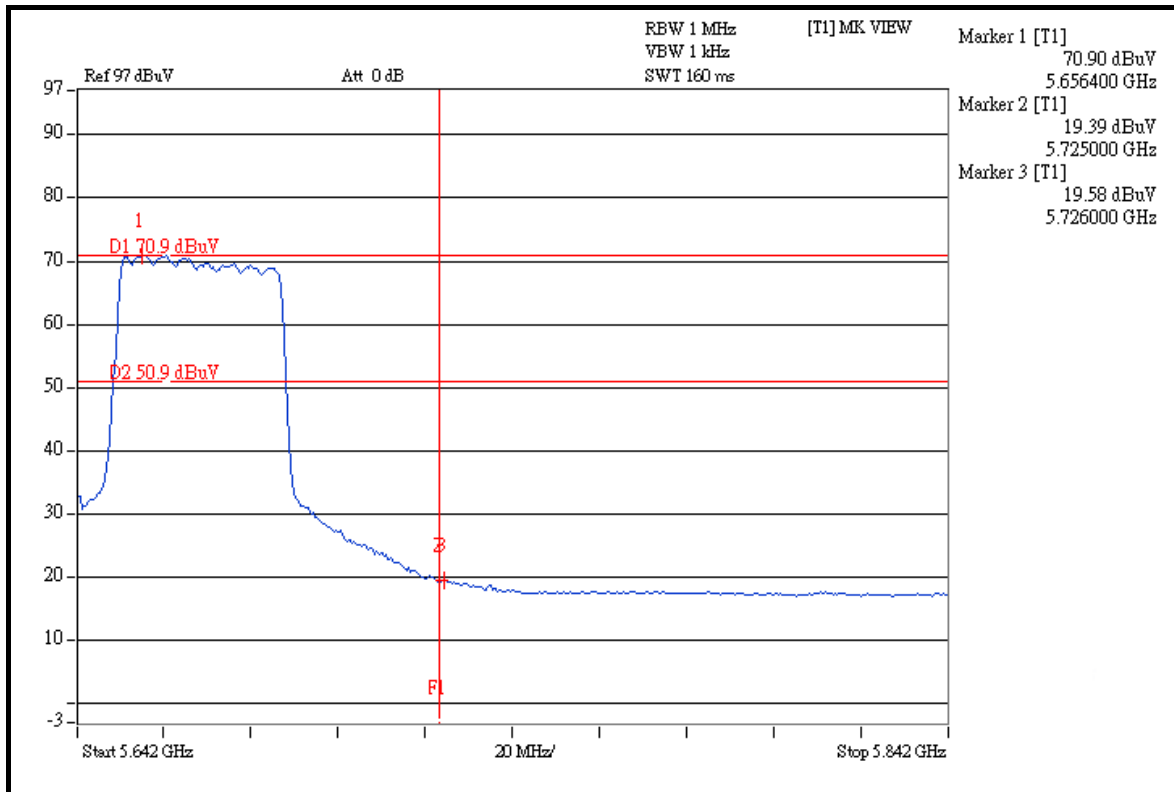

4.8 ANTENNA REQUIREMENT

4.8.1 STANDARD APPLICABLE

For intentional device, according to FCC 47 CFR Section 15.203, an intentional radiator shall be designed to ensure that no antenna other than that furnished by the responsible party shall be used with the device.

And according to FCC 47 CFR Section 15.407(a), if transmitting antennas of directional gain greater than 6dBi are used, the power shall be reduced by the amount in dB that the directional gain of the antenna exceeds 6dBi.

4.8.2 ANTENNA CONNECTED CONSTRUCTION

The antenna used in this product is dipole antenna with R-SMA connector. The maximum Gain of the antenna is 2dBi.

5. PHOTOGRAPHS OF THE TEST CONFIGURATION

Please refer to the attached file (Test Setup Photo).

6. INFORMATION ON THE TESTING LABORATORIES

We, Bureau Veritas Consumer Products Services (H.K.) Ltd., Taoyuan Branch, were founded in 1988 to provide our best service in EMC, Radio, Telecom and Safety consultation. Our laboratories are accredited and approved by the following approval agencies according to ISO/IEC 17025.

USA	FCC, NVLAP
Germany	TUV Rheinland
Japan	VCCI
Norway	NEMKO
Canada	INDUSTRY CANADA, CSA
R.O.C.	TAF, BSMI, NCC
Netherlands	Telefication
Singapore	GOST-ASIA(MOU)
Russia	CERTIS(MOU)

Copies of accreditation certificates of our laboratories obtained from approval agencies can be downloaded from our web site:
www.adt.com.tw/index.5/phtml. If you have any comments, please feel free to contact us at the following:

Linko EMC/RF Lab:
Tel: 886-2-26052180
Fax: 886-2-26051924

Hsin Chu EMC/RF Lab:
Tel: 886-3-5935343
Fax: 886-3-5935342

Hwa Ya EMC/RF/Safety Telecom Lab:
Tel: 886-3-3183232
Fax: 886-3-3185050

Web Site: www.adt.com.tw

The address and road map of all our labs can be found in our web site also.

7. APPENDIX A - MODIFICATIONS RECORDERS FOR ENGINEERING CHANGES TO THE EUT BY THE LAB

No any modifications are made to the EUT by the lab during the test.

---END---