



FCC TEST REPORT

REPORT NO.: RF960202L03

MODEL NO.: DIR-625

RECEIVED: Jan. 13, 2007

TESTED: Jan. 13 ~ Feb. 05, 2007

ISSUED: Feb. 08, 2007

APPLICANT: D-Link Corporation

ADDRESS: 17595 Mt. Herrmann, Fountain Valley, CA
92708, U.S.A.

ISSUED BY: Advance Data Technology Corporation

LAB ADDRESS: No.47, 14th Ling, Chia Pau Tsuen, Linko Hsiang
244, Taipei Hsien, Taiwan, R.O.C.

TEST LOCATION: No. 19, Hwa Ya 2nd Rd, Wen Hwa Tsuen, Kwei
Shan Hsiang, Taoyuan Hsien 333, Taiwan,
R.O.C.

This test report consists of 112 pages in total. It may be duplicated completely for legal use with the approval of the applicant. It should not be reproduced except in full, without the written approval of our laboratory. The client should not use it to claim product endorsement by CNLA, A2LA or any government agencies. The test results in the report only apply to the tested sample.





TABLE OF CONTENTS

1.	CERTIFICATION	4
2.	SUMMARY OF TEST RESULTS	5
2.1	MEASUREMENT UNCERTAINTY	5
3.	GENERAL INFORMATION	6
3.1	GENERAL DESCRIPTION OF EUT	6
3.2	DESCRIPTION OF TEST MODES	7
3.2.1	CONFIGURATION OF SYSTEM UNDER TEST	7
3.2.2	TEST MODE APPLICABILITY AND TESTED CHANNEL DETAIL	8
3.3	GENERAL DESCRIPTION OF APPLIED STANDARDS	10
3.4	DESCRIPTION OF SUPPORT UNITS	10
4.	TEST TYPES AND RESULTS	11
4.1	CONDUCTED EMISSION MEASUREMENT	11
4.1.1	LIMITS OF CONDUCTED EMISSION MEASUREMENT	11
4.1.2	TEST INSTRUMENTS	11
4.1.3	TEST PROCEDURES	12
4.1.4	DEVIATION FROM TEST STANDARD	12
4.1.5	TEST SETUP	13
4.1.6	EUT OPERATING CONDITIONS	13
4.1.7	TEST RESULTS	14
4.2	RADIATED EMISSION MEASUREMENT	32
4.2.1	LIMITS OF RADIATED EMISSION MEASUREMENT	32
4.2.2	TEST INSTRUMENTS	33
4.2.3	TEST PROCEDURES	34
4.2.4	DEVIATION FROM TEST STANDARD	34
4.2.5	TEST SETUP	35
4.2.6	EUT OPERATING CONDITIONS	35
4.2.7	TEST RESULTS	36
4.3	6dB BANDWIDTH MEASUREMENT	51
4.3.1	LIMITS OF 6dB BANDWIDTH MEASUREMENT	51
4.3.2	TEST INSTRUMENTS	51
4.3.3	TEST PROCEDURE	51
4.3.4	DEVIATION FROM TEST STANDARD	51
4.3.5	TEST SETUP	52
4.3.6	EUT OPERATING CONDITIONS	52
4.3.7	TEST RESULTS	53
4.4	MAXIMUM PEAK OUTPUT POWER	69
4.4.1	LIMITS OF MAXIMUM PEAK OUTPUT POWER MEASUREMENT	69
4.4.2	INSTRUMENTS	69
4.4.3	TEST PROCEDURES	69
4.4.4	DEVIATION FROM TEST STANDARD	69
4.4.5	TEST SETUP	70
4.4.6	EUT OPERATING CONDITIONS	70
4.4.7	TEST RESULTS	71
4.5	POWER SPECTRAL DENSITY MEASUREMENT	73
4.5.1	LIMITS OF POWER SPECTRAL DENSITY MEASUREMENT	73
4.5.2	TEST INSTRUMENTS	73
4.5.3	TEST PROCEDURE	73
4.5.4	DEVIATION FROM TEST STANDARD	73



4.5.5	TEST SETUP	74
4.5.6	EUT OPERATING CONDITION	74
4.5.7	TEST RESULTS.....	75
4.6	BAND EDGES MEASUREMENT.....	91
4.6.1	LIMITS OF BAND EDGES MEASUREMENT	91
4.6.2	TEST INSTRUMENTS	91
4.6.3	TEST PROCEDURE	92
4.6.4	DEVIATION FROM TEST STANDARD	92
4.6.5	EUT OPERATING CONDITION	92
4.6.6	TEST RESULTS.....	93
4.7	ANTENNA REQUIREMENT.....	109
4.7.1	STANDARD APPLICABLE.....	109
4.7.2	ANTENNA CONNECTED CONSTRUCTION	109
5.	PHOTOGRAPHS OF THE TEST CONFIGURATION.....	110
6.	INFORMATION ON THE TESTING LABORATORIES	111
	APPENDIX-A.....	A-1



1. CERTIFICATION

PRODUCT: D-Link DIR-625 RANGEBOOSTER N ROUTER

MODEL: DIR-625

BRAND: D-Link

APPLICANT: D-Link Corporation

TESTED: Jan. 13 ~ Feb. 05, 2007

TEST SAMPLE: ENGINEERING SAMPLE

STANDARDS: FCC Part 15, Subpart C (Section 15.247),
ANSI C63.4-2003

The above equipment (Model: DIR-625) has been tested by Advance Data Technology Corporation, and found compliance with the requirement of the above standards. The test record, data evaluation & Equipment Under Test (EUT) configurations represented herein are true and accurate accounts of the measurements of the sample's EMC characteristics under the conditions specified in this report.

PREPARED BY : Andrea Hsia , **DATE:** Feb. 08, 2007
Andrea Hsia

TECHNICAL
ACCEPTANCE : Long Chen , **DATE:** Feb. 08, 2007
Responsible for RF Long Chen

APPROVED BY : Gary Chang , **DATE:** Feb. 08, 2007
Gary Chang / Supervisor

2. SUMMARY OF TEST RESULTS

The EUT has been tested according to the following specifications:

APPLIED STANDARD: FCC Part 15, Subpart C			
STANDARD SECTION	TEST TYPE AND LIMIT	RESULT	REMARK
15.207	AC Power Conducted Emission	PASS	Meet the requirement of limit. Minimum passing margin is -15.21dB at 0.189MHz.
15.247(a)(2)	Spectrum Bandwidth of a Direct Sequence Spread Spectrum System Limit : min. 500kHz	PASS	Meet the requirement of limit.
15.247(b)	Maximum Peak Output Power Limit: max. 30dBm	PASS	Meet the requirement of limit.
15.247(d)	Transmitter Radiated Emissions Limit: Table 15.209	PASS	Meet the requirement of limit. Minimum passing margin is -1.34dB at 2390.00MHz.
15.247(e)	Power Spectral Density Limit: max. 8dBm	PASS	Meet the requirement of limit.
15.247(d)	Band Edge Measurement Limit: 20dB less than the peak value of fundamental frequency	PASS	Meet the requirement of limit.

2.1 MEASUREMENT UNCERTAINTY

Where relevant, the following measurement uncertainty levels have been estimated for tests performed on the EUT as specified in CISPR 16-4:

MEASUREMENT	FREQUENCY	UNCERTAINTY
Conducted emissions	9kHz~30MHz	2.44 dB
Radiated emissions	30MHz ~ 200MHz	3.59 dB
	200MHz ~ 1000MHz	3.61 dB
	1GHz ~ 18GHz	2.26 dB
	18GHz ~ 40GHz	1.94 dB

This uncertainty represents an expanded uncertainty expressed at approximately the 95% confidence level using a coverage factor of $k = 2$.

3. GENERAL INFORMATION

3.1 GENERAL DESCRIPTION OF EUT

PRODUCT	D-Link DIR-625 RANGEBOOSTER N ROUTER
MODEL NO.	DIR-625
FCC ID	KA2DIR625C1
POWER SUPPLY	5Vdc from AC Adapter
MODULATION TYPE	CCK, DQPSK, DBPSK for DSSS 64QAM, 16QAM, QPSK, BPSK for OFDM
MODULATION TECHNOLOGY	DSSS, OFDM
TRANSFER RATE	802.11b: 11/ 5.5/ 2/ 1Mbps 802.11g: 54/ 48/ 36/ 24/ 18/ 12/ 9/ 6Mbps Draft 802.11n (20MHz): 144.444/ 130.000/ 115.556/ 86.667/ 57.778/ 43.333/ 28.889/ 14.444/ 72.2/ 65.0/ 57.8/ 43.3/ 28.9/ 21.7/ 14.4/ 7.2Mbps Draft 802.11n (40MHz): 300/ 270/ 240/ 180/ 120/ 90/ 60/ 30/ 150/ 135/ 120/ 90/ 60/ 45/ 30/ 15Mbps
FREQUENCY RANGE	2400MHz ~ 2483.5MHz
NUMBER OF CHANNEL	11 for 802.11b, 802.11g, draft 802.11n (20MHz) 7 for draft 802.11n (40MHz)
MAXIMUM OUTPUT POWER	129.136mW
ANTENNA TYPE	Dipole antenna with 2.0dBi gain
DATA CABLE	NA
I/O PORTS	USB
ASSOCIATED DEVICES	Adapter

NOTE:

1. The EUT was operated with following power adapter:

BRAND:	D-Link
MODEL:	AF-1805-A
INPUT:	100-120Vac, 50-60Hz, 0.4A
OUTPUT:	5.0Vdc, 3A
POWER LINE:	1.8m non-shielded cable without core

2. The EUT incorporates a MIMO function with 802.11b, 802.11g, draft 802.11n. Physically, the card provides two completed transmitters and two receivers.
3. The EUT is 2 * 2 spatial MIMO (2Tx & 2Rx) without beam forming function that only operate dual chain configuration (both chain 0 and chain 1 transceivers are operational).
4. When the EUT operating in 802.11b, 802.11g, the software operation, which is defined by manufacturer, only set dual Tx.
5. When the EUT operating in draft 802.11n, the software operation, which is defined by manufacturer, only set 0 ~ 15 of "MCS" (MCS: Modulation and Coding Schemes) for dual Tx.
6. The EUT complies with draft 802.11n standards and backwards compatible with 802.11b, 802.11g products.
7. The EUT operates in the 2.4GHz frequency spectrum with throughput of up to 300Mbps.
8. The above EUT information was declared by manufacturer and for more detailed features description, please refer to the manufacturer's specifications or user's manual.

3.2 DESCRIPTION OF TEST MODES

Eleven channels are provided for 802.11b, 802.11g, draft 802.11n (20MHz):

CHANNEL	FREQUENCY	CHANNEL	FREQUENCY
1	2412MHz	7	2442MHz
2	2417MHz	8	2447MHz
3	2422MHz	9	2452MHz
4	2427MHz	10	2457MHz
5	2432MHz	11	2462MHz
6	2437MHz		

Seven channels are provided for draft 802.11n (40MHz):

CHANNEL	FREQUENCY	CHANNEL	FREQUENCY
1	2422MHz	5	2442MHz
2	2427MHz	6	2447MHz
3	2432MHz	7	2452MHz
4	2437MHz		

3.2.1 CONFIGURATION OF SYSTEM UNDER TEST

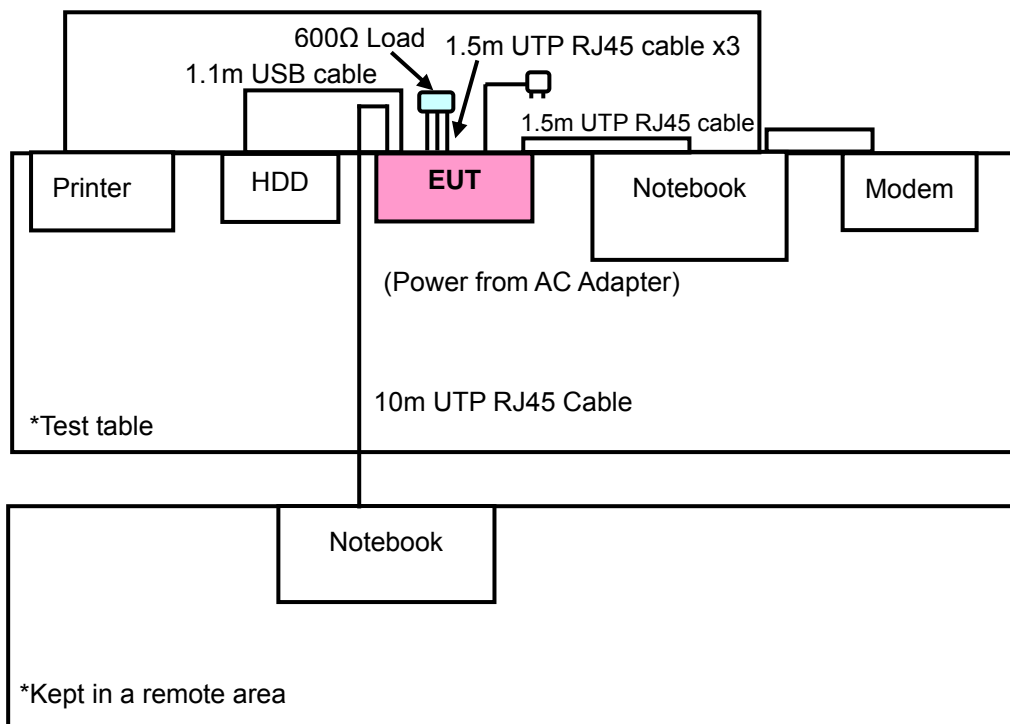

3.2.2 TEST MODE APPLICABILITY AND TESTED CHANNEL DETAIL

EUT CONFIGURE MODE	APPLICABLE TO				DESCRIPTION
	PLC	RE < 1G	RE ≥ 1G	APCM	
-	√	√	√	√	-

Where **PLC**: Power Line Conducted Emission **RE < 1G**: Radiated Emission below 1GHz
RE ≥ 1G: Radiated Emission above 1GHz **APCM**: Antenna Port Conducted Measurement

POWER LINE CONDUCTED EMISSION TEST:

- Pre-Scan has been conducted to determine the worst-case mode from all possible combinations between available modulations, data rates and antenna ports (if EUT with antenna diversity architecture).
- Following channel(s) was (were) selected for the final test as listed below.

MODE	AVAILABLE CHANNEL	TESTED CHANNEL	MODULATION TECHNOLOGY	MODULATION TYPE	DATA RATE (Mbps)	TX CONDITION
802.11g	1 to 11	1, 6, 11	OFDM	BPSK	6	Dual
Draft 802.11n (20MHz)	1 to 11	1, 6, 11	OFDM	BPSK	7.2	Dual
Draft 802.11n (40MHz)	1 to 7	1, 4, 7	OFDM	BPSK	15	Dual

RADIATED EMISSION TEST (BELOW 1 GHz):

- Pre-Scan has been conducted to determine the worst-case mode from all possible combinations between available modulations, data rates and antenna ports (if EUT with antenna diversity architecture).
- Following channel(s) was (were) selected for the final test as listed below.

MODE	AVAILABLE CHANNEL	TESTED CHANNEL	MODULATION TECHNOLOGY	MODULATION TYPE	DATA RATE (Mbps)	TX CONDITION
802.11g	1 to 11	1	OFDM	BPSK	6	Dual
Draft 802.11n (20MHz)	1 to 11	1	OFDM	BPSK	7.2	Dual
Draft 802.11n (40MHz)	1 to 7	1	OFDM	BPSK	15	Dual

RADIATED EMISSION TEST (ABOVE 1 GHz):

- Pre-Scan has been conducted to determine the worst-case mode from all possible combinations between available modulations, data rates and antenna ports (if EUT with antenna diversity architecture).
- Following channel(s) was (were) selected for the final test as listed below.

MODE	AVAILABLE CHANNEL	TESTED CHANNEL	MODULATION TECHNOLOGY	MODULATION TYPE	DATA RATE (Mbps)	TX CONDITION
802.11b	1 to 11	1, 6, 11	DSSS	DBPSK	1	Dual
802.11g	1 to 11	1, 6, 11	OFDM	BPSK	6	Dual
Draft 802.11n (20MHz)	1 to 11	1, 6, 11	OFDM	BPSK	7.2	Dual
Draft 802.11n (40MHz)	1 to 7	1, 4, 7	OFDM	BPSK	15	Dual

BANDEDGE MEASUREMENT:

- Pre-Scan has been conducted to determine the worst-case mode from all possible combinations between available modulations, data rates and antenna ports (if EUT with antenna diversity architecture).
- Following channel(s) was (were) selected for the final test as listed below.

MODE	AVAILABLE CHANNEL	TESTED CHANNEL	MODULATION TECHNOLOGY	MODULATION TYPE	DATA RATE (Mbps)	TX CONDITION
802.11b	1 to 11	1, 11	DSSS	DBPSK	1	Dual
802.11g	1 to 11	1, 11	OFDM	BPSK	6	Dual
Draft 802.11n (20MHz)	1 to 11	1, 11	OFDM	BPSK	7.2	Dual
Draft 802.11n (40MHz)	1 to 7	1, 7	OFDM	BPSK	15	Dual

ANTENNA PORT CONDUCTED MEASUREMENT:

- Pre-Scan has been conducted to determine the worst-case mode from all possible combinations between available modulations, data rates and antenna ports (if EUT with antenna diversity architecture).
- Following channel(s) was (were) selected for the final test as listed below.

MODE	AVAILABLE CHANNEL	TESTED CHANNEL	MODULATION TECHNOLOGY	MODULATION TYPE	DATA RATE (Mbps)	TX CONDITION
802.11b	1 to 11	1, 6, 11	DSSS	DBPSK	1	Dual
802.11g	1 to 11	1, 6, 11	OFDM	BPSK	6	Dual
Draft 802.11n (20MHz)	1 to 11	1, 6, 11	OFDM	BPSK	7.2	Dual
Draft 802.11n (40MHz)	1 to 7	1, 4, 7	OFDM	BPSK	15	Dual



3.3 GENERAL DESCRIPTION OF APPLIED STANDARDS

The EUT is a RF product. According to the specifications of the manufacturer, it must comply with the requirements of the following standards:

FCC Part 15, Subpart C. (15.247)

ANSI C63.4-2003

All test items have been performed and recorded as per the above standards.

NOTE: The EUT is also considered as a kind of computer peripheral, because the connection to computer is necessary for typical use. It has been verified to comply with the requirements of FCC Part 15, Subpart B, Class B (DoC). The test report has been issued separately.

3.4 DESCRIPTION OF SUPPORT UNITS

The EUT has been tested as an independent unit together with other necessary accessories or support units. The following support units or accessories were used to form a representative test configuration during the tests.

NO.	PRODUCT	BRAND	MODEL NO.	SERIAL NO.	FCC ID
1	NOTEBOOK COMPUTER	DELL	PP05L	16484462992	E2K24CLNS
2	PRINTER	EPSON	LQ-300+	DCGY054147	FCC DoC Approved
3	MODEM	ACEEX	1414V/3	0401008269	IFAXDM1414
4	FIREWIRE HARD DRIVE	Terasys	F12-UF	A0100222-4A60001	FCC DoC Approved
5	NOTEBOOK COMPUTER	DELL	PP05L	12130898320	E2K24CLNS

NO.	SIGNAL CABLE DESCRIPTION OF THE ABOVE SUPPORT UNITS
1	1.5m UTP RJ45 cable
2	1.2m shielded cable
3	1.3m shielded cable
4	1.1m shielded cable
5	10m UTP RJ45 cable

NOTE: 1. All power cords of the above support units are non shielded (1.8m).
2. Item 5 acted as communication partners to transfer data.

4. TEST TYPES AND RESULTS

4.1 CONDUCTED EMISSION MEASUREMENT

4.1.1 LIMITS OF CONDUCTED EMISSION MEASUREMENT

FREQUENCY OF EMISSION (MHz)	CONDUCTED LIMIT (dB μ V)	
	Quasi-peak	Average
0.15-0.5	66 to 56	56 to 46
0.5-5	56	46
5-30	60	50

- NOTE:**
1. The lower limit shall apply at the transition frequencies.
 2. The limit decreases in line with the logarithm of the frequency in the range of 0.15 to 0.50 MHz.
 3. All emanations from a class A/B digital device or system, including any network of conductors and apparatus connected thereto, shall not exceed the level of field strengths specified above.

4.1.2 TEST INSTRUMENTS

DESCRIPTION & MANUFACTURER	MODEL NO.	SERIAL NO.	CALIBRATED UNTIL
Test Receiver ROHDE & SCHWARZ	ESCS30	100288	Sep. 25, 2007
RF signal cable Woken	5D-FB	Cable-HYCO3-01	Jan. 06, 2008
LISN ROHDE & SCHWARZ	ESH2-Z5	100100	Jan. 08, 2008
LISN ROHDE & SCHWARZ	ESH3-Z5	100311	Jan. 16, 2008
Software ADT	ADT_Cond_V3	NA	NA

- NOTE:**
1. The calibration interval of the above test instruments is 12 months and the calibrations are traceable to NML/ROC and NIST/USA.
 2. The test was performed in HwaYa Shielded Room 2.
 3. The VCCI Site Registration No. is C-2047.

4.1.3 TEST PROCEDURES

- a. The EUT was placed 0.4 meters from the conducting wall of the shielded room with EUT being connected to the power mains through a line impedance stabilization network (LISN). Other support units were connected to the power mains through another LISN. The two LISNs provide 50 ohm/ 50uH of coupling impedance for the measuring instrument.
- b. Both lines of the power mains connected to the EUT were checked for maximum conducted interference.
- c. The frequency range from 150kHz to 30MHz was searched. Emission levels under (Limit - 20dB) was not recorded.

4.1.4 DEVIATION FROM TEST STANDARD

No deviation

4.1.5 TEST SETUP

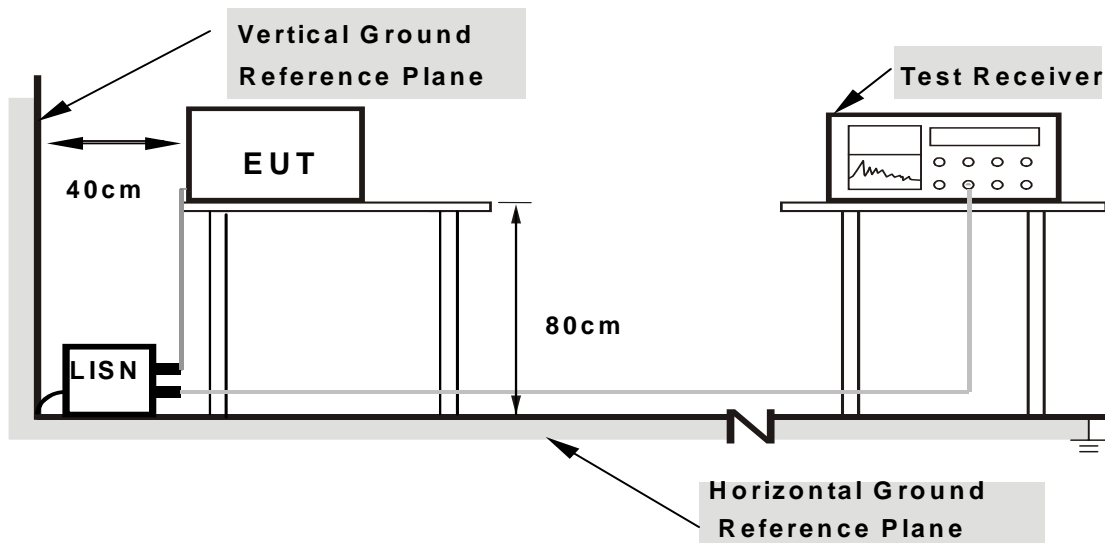

Note: 1. Support units were connected to second LISN.

2. Both of LISNs (AMN) are 80 cm from EUT and at least 80 from other units and other metal planes

For the actual test configuration, please refer to the attached file (Test Setup Photo).

4.1.6 EUT OPERATING CONDITIONS

- Connected the EUT to the Notebook system and placed on a testing table.
- Prepared a notebook computer and placed it outside of testing area to act as communication partner for EUT.
- The Notebook system ran a test program (provided by manufacturer) to enable EUT under transmission condition continuously at specific channel frequency.
- The necessary accessories enable the EUT in full functions.

4.1.7 TEST RESULTS

CONDUCTED WORST-CASE DATA: 802.11g OFDM MODULATION:

EUT TEST CONDITION		MEASUREMENT DETAIL	
CHANNEL	Channel 1	PHASE	Line 1
MODULATION TYPE	BPSK	6dB BANDWIDTH	9 kHz
TRANSFER RATE	6Mbps	INPUT POWER (SYSTEM)	120Vac, 60 Hz
ENVIRONMENTAL CONDITIONS	22deg. C, 60%RH, 991hPa	TESTED BY	Dean Wang

No	Freq. [MHz]	Corr. Factor (dB)	Reading Value [dB (uV)]		Emission Level [dB (uV)]		Limit [dB (uV)]		Margin (dB)	
			Q.P.	AV.	Q.P.	AV.	Q.P.	AV.	Q.P.	AV.
1	0.189	0.10	44.71	-	44.81	-	64.08	54.08	-19.27	-
2	0.318	0.10	29.98	-	30.08	-	59.76	49.76	-29.68	-
3	0.505	0.10	38.29	-	38.39	-	56.00	46.00	-17.61	-
4	2.474	0.23	38.44	-	38.67	-	56.00	46.00	-17.33	-
5	9.676	0.33	30.55	-	30.88	-	60.00	50.00	-29.12	-
6	18.715	0.55	39.46	-	40.01	-	60.00	50.00	-19.99	-

- REMARKS:**
1. Q.P. and AV. are abbreviations of quasi-peak and average individually.
 2. "-": The Quasi-peak reading value also meets average limit and measurement with the average detector is unnecessary.
 3. The emission levels of other frequencies were very low against the limit.
 4. Margin value = Emission level - Limit value
 5. Correction factor = Insertion loss + Cable loss
 6. Emission Level = Correction Factor + Reading Value.

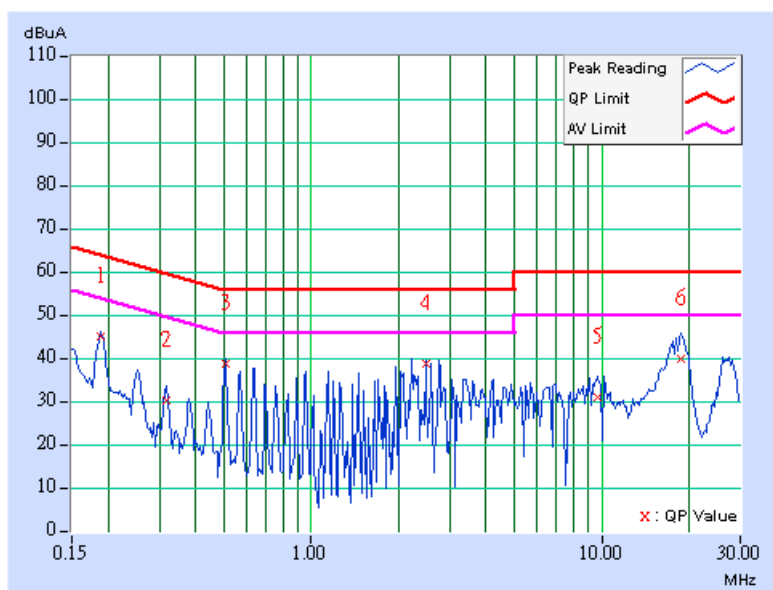

EUT TEST CONDITION		MEASUREMENT DETAIL	
CHANNEL	Channel 1	PHASE	Line 2
MODULATION TYPE	BPSK	6dB BANDWIDTH	9 kHz
TRANSFER RATE	6Mbps	INPUT POWER (SYSTEM)	120Vac, 60 Hz
ENVIRONMENTAL CONDITIONS	22deg. C, 60%RH, 991hPa	TESTED BY	Dean Wang

No	Freq.	Corr.	Reading Value		Emission Level		Limit		Margin	
	[MHz]	Factor	[dB (uV)]		[dB (uV)]		[dB (uV)]		(dB)	
		(dB)	Q.P.	AV.	Q.P.	AV.	Q.P.	AV.	Q.P.	AV.
1	0.189	0.10	48.77	-	48.87	-	64.08	54.08	-15.21	-
2	0.380	0.10	37.65	-	37.75	-	58.27	48.27	-20.52	-
3	0.505	0.12	39.11	-	39.23	-	56.00	46.00	-16.77	-
4	2.220	0.23	38.54	-	38.77	-	56.00	46.00	-17.23	-
5	8.934	0.40	28.73	-	29.13	-	60.00	50.00	-30.87	-
6	18.609	0.54	42.97	-	43.51	-	60.00	50.00	-16.49	-

- REMARKS:**
1. Q.P. and AV. are abbreviations of quasi-peak and average individually.
 2. "-": The Quasi-peak reading value also meets average limit and measurement with the average detector is unnecessary.
 3. The emission levels of other frequencies were very low against the limit.
 4. Margin value = Emission level - Limit value
 5. Correction factor = Insertion loss + Cable loss
 6. Emission Level = Correction Factor + Reading Value.

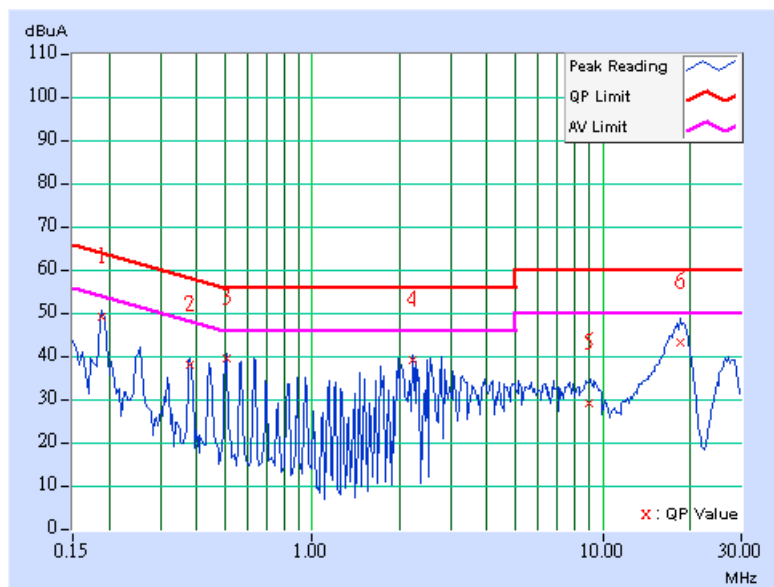

EUT TEST CONDITION		MEASUREMENT DETAIL	
CHANNEL	Channel 6	PHASE	Line 1
MODULATION TYPE	BPSK	6dB BANDWIDTH	9 kHz
TRANSFER RATE	6Mbps	INPUT POWER (SYSTEM)	120Vac, 60 Hz
ENVIRONMENTAL CONDITIONS	22deg. C, 60%RH, 991hPa	TESTED BY	Dean Wang

No	Freq.	Corr.	Reading Value		Emission Level		Limit		Margin	
	[MHz]	Factor	[dB (uV)]		[dB (uV)]		[dB (uV)]		(dB)	
		(dB)	Q.P.	AV.	Q.P.	AV.	Q.P.	AV.	Q.P.	AV.
1	0.189	0.10	44.52	-	44.62	-	64.08	54.08	-19.46	-
2	0.252	0.10	35.65	-	35.75	-	61.71	51.71	-25.96	-
3	0.504	0.10	38.67	-	38.77	-	56.00	46.00	-17.23	-
4	2.472	0.23	38.11	-	38.34	-	56.00	46.00	-17.66	-
5	9.328	0.32	32.33	-	32.65	-	60.00	50.00	-27.35	-
6	18.672	0.55	40.46	-	41.01	-	60.00	50.00	-18.99	-

- REMARKS:**
1. Q.P. and AV. are abbreviations of quasi-peak and average individually.
 2. "-": The Quasi-peak reading value also meets average limit and measurement with the average detector is unnecessary.
 3. The emission levels of other frequencies were very low against the limit.
 4. Margin value = Emission level - Limit value
 5. Correction factor = Insertion loss + Cable loss
 6. Emission Level = Correction Factor + Reading Value.

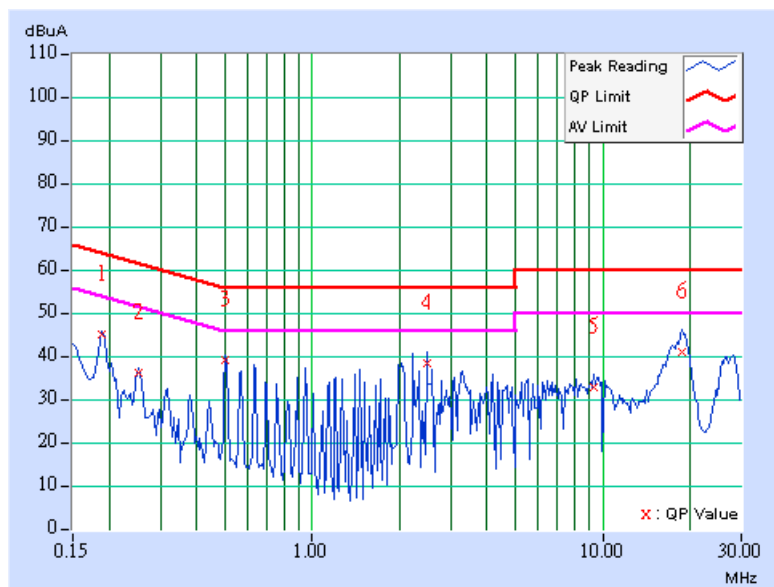

EUT TEST CONDITION		MEASUREMENT DETAIL	
CHANNEL	Channel 6	PHASE	Line 2
MODULATION TYPE	BPSK	6dB BANDWIDTH	9 kHz
TRANSFER RATE	6Mbps	INPUT POWER (SYSTEM)	120Vac, 60 Hz
ENVIRONMENTAL CONDITIONS	22deg. C, 60%RH, 991hPa	TESTED BY	Dean Wang

No	Freq. [MHz]	Corr. Factor (dB)	Reading Value [dB (uV)]		Emission Level [dB (uV)]		Limit [dB (uV)]		Margin (dB)	
			Q.P.	AV.	Q.P.	AV.	Q.P.	AV.	Q.P.	AV.
			1	0.189	0.10	48.65	-	48.75	-	64.08
2	0.252	0.10	41.05	-	41.15	-	61.71	51.71	-20.56	-
3	0.505	0.12	39.25	-	39.37	-	56.00	46.00	-16.63	-
4	2.789	0.24	38.37	-	38.61	-	56.00	46.00	-17.39	-
5	9.070	0.41	30.17	-	30.58	-	60.00	50.00	-29.42	-
6	19.023	0.55	41.53	-	42.08	-	60.00	50.00	-17.92	-

- REMARKS:**
1. Q.P. and AV. are abbreviations of quasi-peak and average individually.
 2. "-": The Quasi-peak reading value also meets average limit and measurement with the average detector is unnecessary.
 3. The emission levels of other frequencies were very low against the limit.
 4. Margin value = Emission level - Limit value
 5. Correction factor = Insertion loss + Cable loss
 6. Emission Level = Correction Factor + Reading Value.

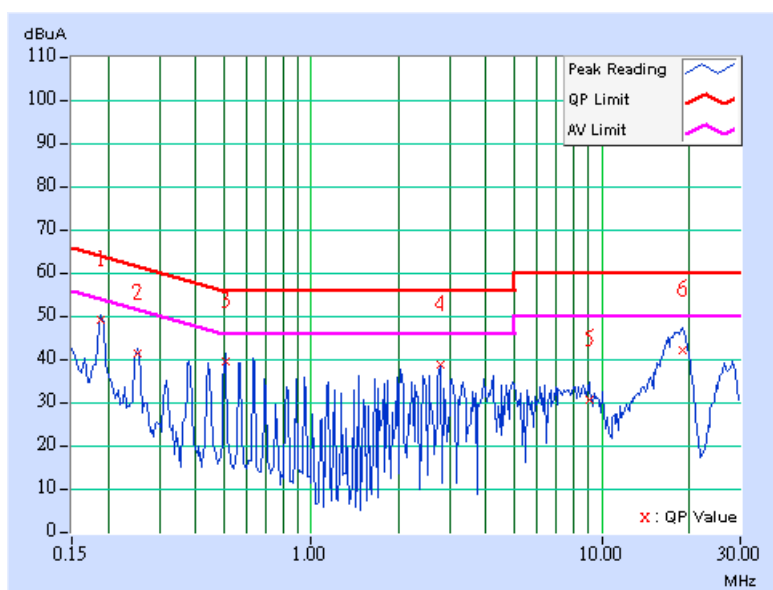

EUT TEST CONDITION		MEASUREMENT DETAIL	
CHANNEL	Channel 11	PHASE	Line 1
MODULATION TYPE	BPSK	6dB BANDWIDTH	9 kHz
TRANSFER RATE	6Mbps	INPUT POWER (SYSTEM)	120Vac, 60 Hz
ENVIRONMENTAL CONDITIONS	22deg. C, 60%RH, 991hPa	TESTED BY	Dean Wang

No	Freq.	Corr.	Reading Value		Emission Level		Limit		Margin	
	[MHz]	Factor	[dB (uV)]		[dB (uV)]		[dB (uV)]		(dB)	
		(dB)	Q.P.	AV.	Q.P.	AV.	Q.P.	AV.	Q.P.	AV.
1	0.189	0.10	44.38	-	44.48	-	64.08	54.08	-19.60	-
2	0.252	0.10	35.54	-	35.64	-	61.71	51.71	-26.07	-
3	0.507	0.10	38.35	-	38.45	-	56.00	46.00	-17.55	-
4	2.223	0.23	38.60	-	38.83	-	56.00	46.00	-17.17	-
5	9.398	0.32	31.95	-	32.27	-	60.00	50.00	-27.73	-
6	18.621	0.55	40.80	-	41.35	-	60.00	50.00	-18.65	-

- REMARKS:**
1. Q.P. and AV. are abbreviations of quasi-peak and average individually.
 2. "-": The Quasi-peak reading value also meets average limit and measurement with the average detector is unnecessary.
 3. The emission levels of other frequencies were very low against the limit.
 4. Margin value = Emission level - Limit value
 5. Correction factor = Insertion loss + Cable loss
 6. Emission Level = Correction Factor + Reading Value.

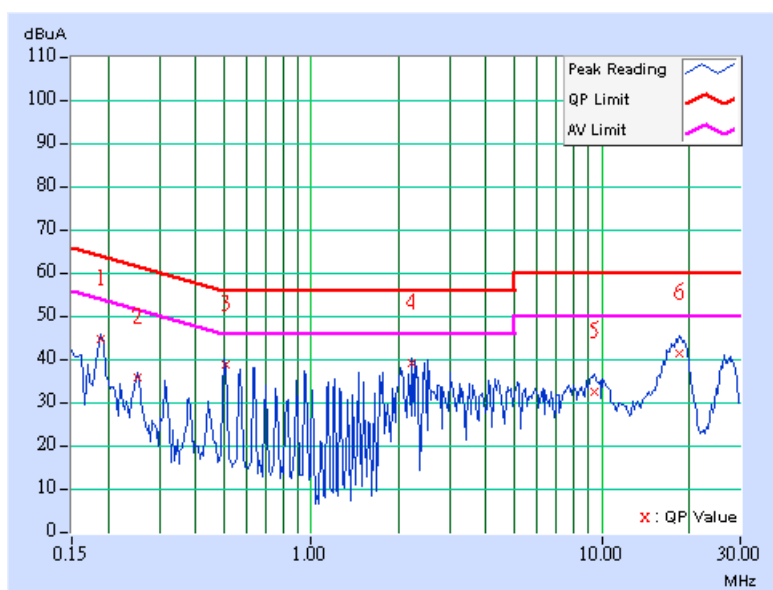

EUT TEST CONDITION		MEASUREMENT DETAIL	
CHANNEL	Channel 11	PHASE	Line 2
MODULATION TYPE	BPSK	6dB BANDWIDTH	9 kHz
TRANSFER RATE	6Mbps	INPUT POWER (SYSTEM)	120Vac, 60 Hz
ENVIRONMENTAL CONDITIONS	22deg. C, 60%RH, 991hPa	TESTED BY	Dean Wang

No	Freq. [MHz]	Corr. Factor (dB)	Reading Value [dB (uV)]		Emission Level [dB (uV)]		Limit [dB (uV)]		Margin (dB)	
			Q.P.	AV.	Q.P.	AV.	Q.P.	AV.	Q.P.	AV.
			1	0.189	0.10	48.59	-	48.69	-	64.08
2	0.252	0.10	41.07	-	41.17	-	61.71	51.71	-20.54	-
3	0.505	0.12	39.39	-	39.51	-	56.00	46.00	-16.49	-
4	2.027	0.22	37.28	-	37.50	-	56.00	46.00	-18.50	-
5	18.605	0.54	42.95	-	43.49	-	60.00	50.00	-16.51	-
6	28.105	0.86	33.79	-	34.65	-	60.00	50.00	-25.35	-

- REMARKS:**
1. Q.P. and AV. are abbreviations of quasi-peak and average individually.
 2. "-": The Quasi-peak reading value also meets average limit and measurement with the average detector is unnecessary.
 3. The emission levels of other frequencies were very low against the limit.
 4. Margin value = Emission level - Limit value
 5. Correction factor = Insertion loss + Cable loss
 6. Emission Level = Correction Factor + Reading Value.

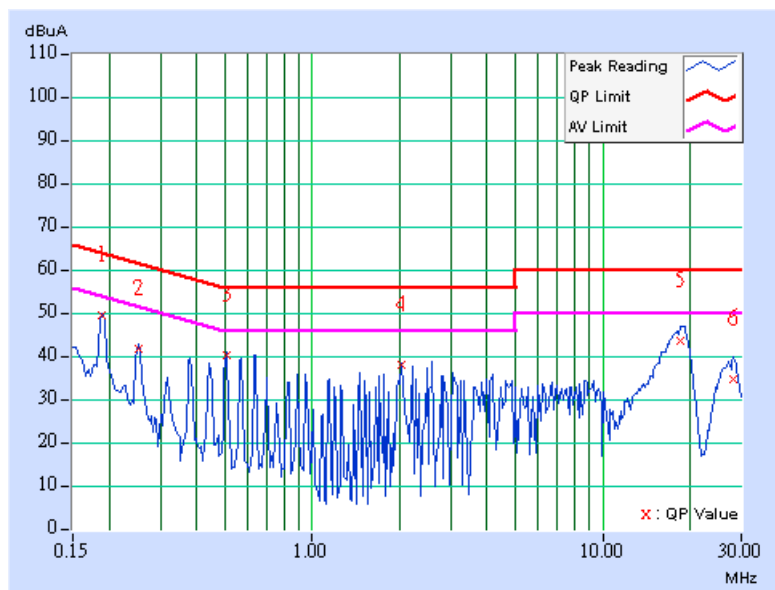

DRAFT 802.11n (20MHz) OFDM MODULATION: DUAL TX:

EUT TEST CONDITION		MEASUREMENT DETAIL	
CHANNEL	Channel 1	PHASE	Line 1
MODULATION TYPE	BPSK	6dB BANDWIDTH	9 kHz
TRANSFER RATE	7.2Mbps	INPUT POWER (SYSTEM)	120Vac, 60 Hz
ENVIRONMENTAL CONDITIONS	22deg. C, 60%RH, 991hPa	TESTED BY	Dean Wang

No	Freq. [MHz]	Corr. Factor (dB)	Reading Value [dB (uV)]		Emission Level [dB (uV)]		Limit [dB (uV)]		Margin (dB)	
			Q.P.	AV.	Q.P.	AV.	Q.P.	AV.	Q.P.	AV.
1	0.189	0.10	44.34	-	44.44	-	64.08	54.08	-19.64	-
2	0.314	0.10	30.56	-	30.66	-	59.86	49.86	-29.20	-
3	0.505	0.10	38.55	-	38.65	-	56.00	46.00	-17.35	-
4	2.590	0.24	36.33	-	36.57	-	56.00	46.00	-19.43	-
5	9.672	0.33	31.15	-	31.48	-	60.00	50.00	-28.52	-
6	18.672	0.55	39.82	-	40.37	-	60.00	50.00	-19.63	-

- REMARKS:**
1. Q.P. and AV. are abbreviations of quasi-peak and average individually.
 2. "-": The Quasi-peak reading value also meets average limit and measurement with the average detector is unnecessary.
 3. The emission levels of other frequencies were very low against the limit.
 4. Margin value = Emission level - Limit value
 5. Correction factor = Insertion loss + Cable loss
 6. Emission Level = Correction Factor + Reading Value.

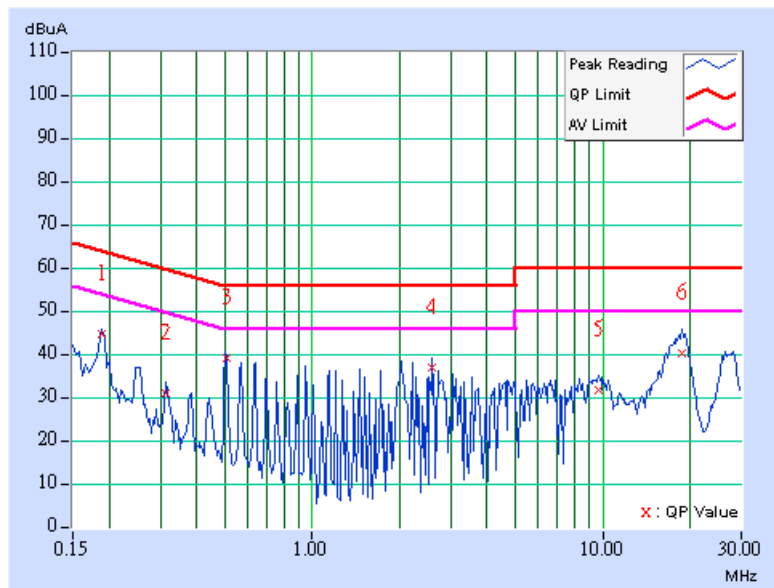

EUT TEST CONDITION		MEASUREMENT DETAIL	
CHANNEL	Channel 1	PHASE	Line 2
MODULATION TYPE	BPSK	6dB BANDWIDTH	9 kHz
TRANSFER RATE	7.2Mbps	INPUT POWER (SYSTEM)	120Vac, 60 Hz
ENVIRONMENTAL CONDITIONS	22deg. C, 60%RH, 991hPa	TESTED BY	Dean Wang

No	Freq. [MHz]	Corr. Factor [dB]	Reading Value [dB (uV)]		Emission Level [dB (uV)]		Limit [dB (uV)]		Margin (dB)	
			Q.P.	AV.	Q.P.	AV.	Q.P.	AV.	Q.P.	AV.
			1	0.189	0.10	48.55	-	48.65	-	64.08
2	0.380	0.10	37.75	-	37.85	-	58.27	48.27	-20.42	-
3	0.634	0.14	38.99	-	39.13	-	56.00	46.00	-16.87	-
4	2.223	0.23	38.78	-	39.01	-	56.00	46.00	-16.99	-
5	7.293	0.36	28.04	-	28.40	-	60.00	50.00	-31.60	-
6	18.109	0.54	41.80	-	42.34	-	60.00	50.00	-17.66	-

- REMARKS:**
1. Q.P. and AV. are abbreviations of quasi-peak and average individually.
 2. "-": The Quasi-peak reading value also meets average limit and measurement with the average detector is unnecessary.
 3. The emission levels of other frequencies were very low against the limit.
 4. Margin value = Emission level - Limit value
 5. Correction factor = Insertion loss + Cable loss
 6. Emission Level = Correction Factor + Reading Value.

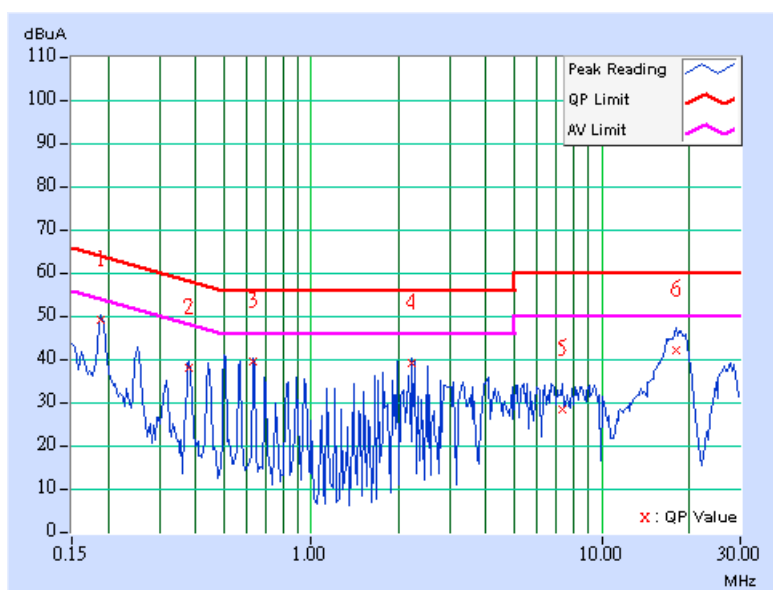

EUT TEST CONDITION		MEASUREMENT DETAIL	
CHANNEL	Channel 6	PHASE	Line 1
MODULATION TYPE	BPSK	6dB BANDWIDTH	9 kHz
TRANSFER RATE	7.2Mbps	INPUT POWER (SYSTEM)	120Vac, 60 Hz
ENVIRONMENTAL CONDITIONS	22deg. C, 60%RH, 991hPa	TESTED BY	Dean Wang

No	Freq.	Corr.	Reading Value		Emission Level		Limit		Margin	
	[MHz]	Factor	[dB (uV)]		[dB (uV)]		[dB (uV)]		(dB)	
		(dB)	Q.P.	AV.	Q.P.	AV.	Q.P.	AV.	Q.P.	AV.
1	0.189	0.10	44.24	-	44.34	-	64.08	54.08	-19.74	-
2	0.252	0.10	35.34	-	35.44	-	61.71	51.71	-26.27	-
3	0.505	0.10	38.65	-	38.75	-	56.00	46.00	-17.25	-
4	2.531	0.24	39.39	-	39.63	-	56.00	46.00	-16.37	-
5	9.590	0.33	33.26	-	33.59	-	60.00	50.00	-26.41	-
6	18.938	0.55	39.86	-	40.41	-	60.00	50.00	-19.59	-

- REMARKS:**
1. Q.P. and AV. are abbreviations of quasi-peak and average individually.
 2. "-": The Quasi-peak reading value also meets average limit and measurement with the average detector is unnecessary.
 3. The emission levels of other frequencies were very low against the limit.
 4. Margin value = Emission level - Limit value
 5. Correction factor = Insertion loss + Cable loss
 6. Emission Level = Correction Factor + Reading Value.

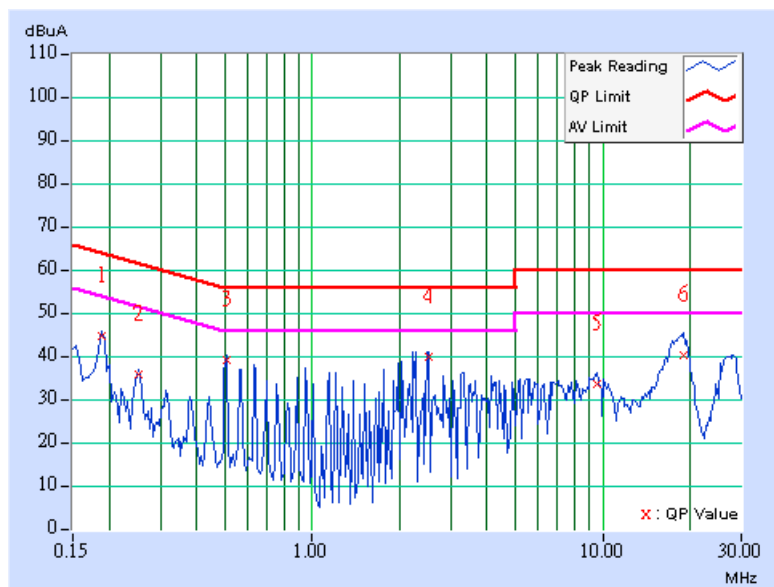

EUT TEST CONDITION		MEASUREMENT DETAIL	
CHANNEL	Channel 6	PHASE	Line 2
MODULATION TYPE	BPSK	6dB BANDWIDTH	9 kHz
TRANSFER RATE	7.2Mbps	INPUT POWER (SYSTEM)	120Vac, 60 Hz
ENVIRONMENTAL CONDITIONS	22deg. C, 60%RH, 991hPa	TESTED BY	Dean Wang

No	Freq. [MHz]	Corr. Factor (dB)	Reading Value [dB (uV)]		Emission Level [dB (uV)]		Limit [dB (uV)]		Margin (dB)	
			Q.P.	AV.	Q.P.	AV.	Q.P.	AV.	Q.P.	AV.
			1	0.193	0.10	46.29	-	46.39	-	63.91
2	0.255	0.10	39.56	-	39.66	-	61.58	51.58	-21.92	-
3	0.507	0.12	39.46	-	39.58	-	56.00	46.00	-16.42	-
4	2.215	0.23	37.97	-	38.20	-	56.00	46.00	-17.80	-
5	7.605	0.37	28.27	-	28.64	-	60.00	50.00	-31.36	-
6	18.832	0.55	42.01	-	42.56	-	60.00	50.00	-17.44	-

- REMARKS:**
1. Q.P. and AV. are abbreviations of quasi-peak and average individually.
 2. "-": The Quasi-peak reading value also meets average limit and measurement with the average detector is unnecessary.
 3. The emission levels of other frequencies were very low against the limit.
 4. Margin value = Emission level - Limit value
 5. Correction factor = Insertion loss + Cable loss
 6. Emission Level = Correction Factor + Reading Value.

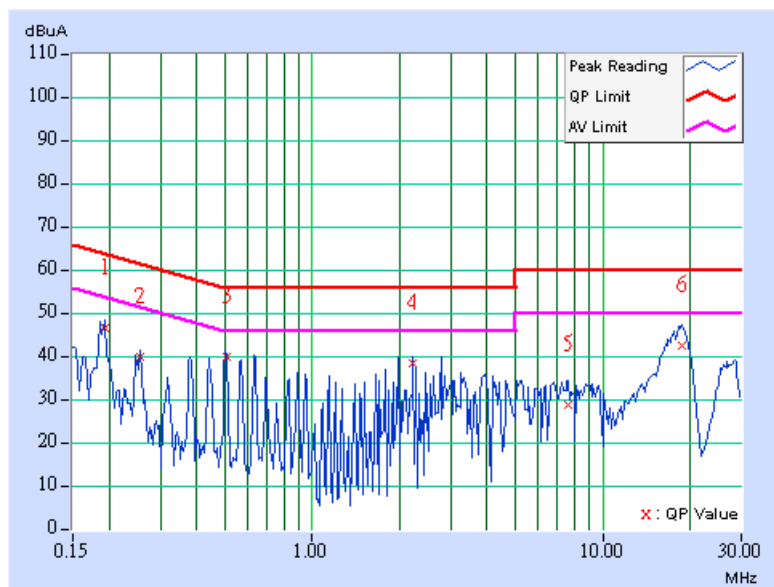

EUT TEST CONDITION		MEASUREMENT DETAIL	
CHANNEL	Channel 11	PHASE	Line 1
MODULATION TYPE	BPSK	6dB BANDWIDTH	9 kHz
TRANSFER RATE	7.2Mbps	INPUT POWER (SYSTEM)	120Vac, 60 Hz
ENVIRONMENTAL CONDITIONS	22deg. C, 60%RH, 991hPa	TESTED BY	Dean Wang

No	Freq. [MHz]	Corr. Factor (dB)	Reading Value [dB (uV)]		Emission Level [dB (uV)]		Limit [dB (uV)]		Margin (dB)	
			Q.P.	AV.	Q.P.	AV.	Q.P.	AV.	Q.P.	AV.
			1	0.189	0.10	44.20	-	44.30	-	64.08
2	0.255	0.10	34.07	-	34.17	-	61.58	51.58	-27.41	-
3	0.505	0.10	38.65	-	38.75	-	56.00	46.00	-17.25	-
4	2.531	0.24	39.41	-	39.65	-	56.00	46.00	-16.35	-
5	9.070	0.32	31.61	-	31.93	-	60.00	50.00	-28.07	-
6	18.918	0.55	40.62	-	41.17	-	60.00	50.00	-18.83	-

- REMARKS:**
1. Q.P. and AV. are abbreviations of quasi-peak and average individually.
 2. "-": The Quasi-peak reading value also meets average limit and measurement with the average detector is unnecessary.
 3. The emission levels of other frequencies were very low against the limit.
 4. Margin value = Emission level - Limit value
 5. Correction factor = Insertion loss + Cable loss
 6. Emission Level = Correction Factor + Reading Value.

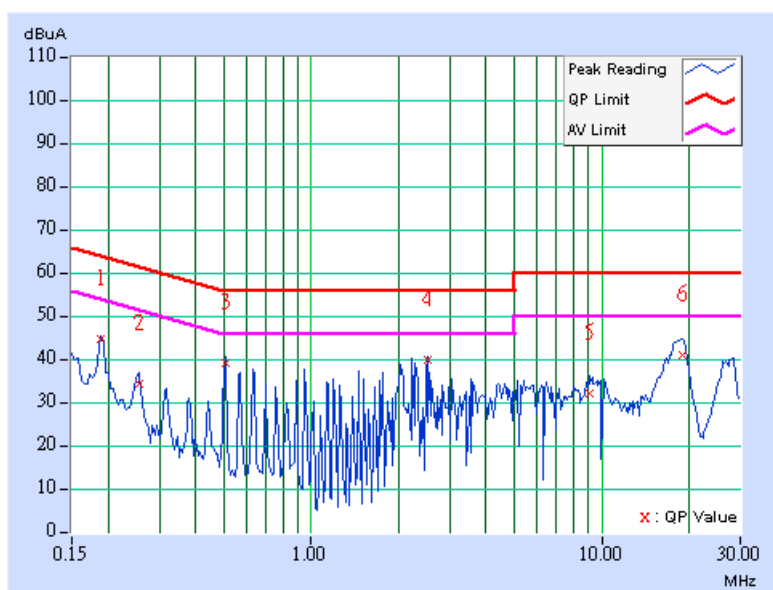

EUT TEST CONDITION		MEASUREMENT DETAIL	
CHANNEL	Channel 11	PHASE	Line 2
MODULATION TYPE	BPSK	6dB BANDWIDTH	9 kHz
TRANSFER RATE	7.2Mbps	INPUT POWER (SYSTEM)	120Vac, 60 Hz
ENVIRONMENTAL CONDITIONS	22deg. C, 60%RH, 991hPa	TESTED BY	Dean Wang

No	Freq. [MHz]	Corr. Factor (dB)	Reading Value [dB (uV)]		Emission Level [dB (uV)]		Limit [dB (uV)]		Margin (dB)	
			Q.P.	AV.	Q.P.	AV.	Q.P.	AV.	Q.P.	AV.
			1	0.189	0.10	48.46	-	48.56	-	64.08
2	0.252	0.10	40.89	-	40.99	-	61.71	51.71	-20.72	-
3	0.505	0.12	39.56	-	39.68	-	56.00	46.00	-16.32	-
4	2.223	0.23	39.06	-	39.29	-	56.00	46.00	-16.71	-
5	9.246	0.41	28.12	-	28.53	-	60.00	50.00	-31.47	-
6	18.594	0.54	41.97	-	42.51	-	60.00	50.00	-17.49	-

- REMARKS:**
1. Q.P. and AV. are abbreviations of quasi-peak and average individually.
 2. "-": The Quasi-peak reading value also meets average limit and measurement with the average detector is unnecessary.
 3. The emission levels of other frequencies were very low against the limit.
 4. Margin value = Emission level - Limit value
 5. Correction factor = Insertion loss + Cable loss
 6. Emission Level = Correction Factor + Reading Value.

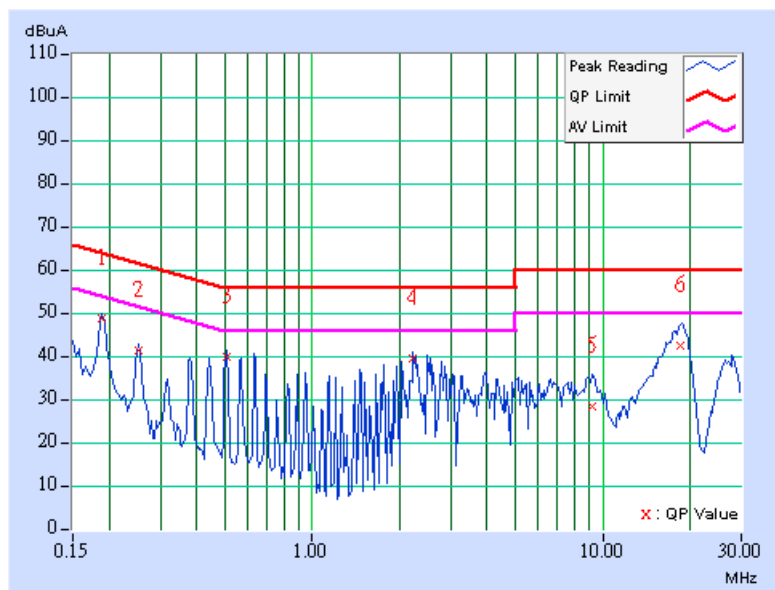

DRAFT 802.11n (40MHz) OFDM MODULATION: DUAL TX:

EUT TEST CONDITION		MEASUREMENT DETAIL	
CHANNEL	Channel 1	PHASE	Line 1
MODULATION TYPE	BPSK	6dB BANDWIDTH	9 kHz
TRANSFER RATE	15Mbps	INPUT POWER (SYSTEM)	120Vac, 60 Hz
ENVIRONMENTAL CONDITIONS	22deg. C, 60%RH, 991hPa	TESTED BY	Dean Wang

No	Freq. [MHz]	Corr. Factor [dB]	Reading Value [dB (uV)]		Emission Level [dB (uV)]		Limit [dB (uV)]		Margin (dB)	
			Q.P.	AV.	Q.P.	AV.	Q.P.	AV.	Q.P.	AV.
1	0.189	0.10	44.18	-	44.28	-	64.08	54.08	-19.80	-
2	0.252	0.10	35.22	-	35.32	-	61.71	51.71	-26.39	-
3	0.506	0.10	38.67	-	38.77	-	56.00	46.00	-17.23	-
4	2.789	0.24	37.92	-	38.16	-	56.00	46.00	-17.84	-
5	9.805	0.33	30.06	-	30.39	-	60.00	50.00	-29.61	-
6	18.910	0.55	41.18	-	41.73	-	60.00	50.00	-18.27	-

- REMARKS:**
1. Q.P. and AV. are abbreviations of quasi-peak and average individually.
 2. "-": The Quasi-peak reading value also meets average limit and measurement with the average detector is unnecessary.
 3. The emission levels of other frequencies were very low against the limit.
 4. Margin value = Emission level - Limit value
 5. Correction factor = Insertion loss + Cable loss
 6. Emission Level = Correction Factor + Reading Value.

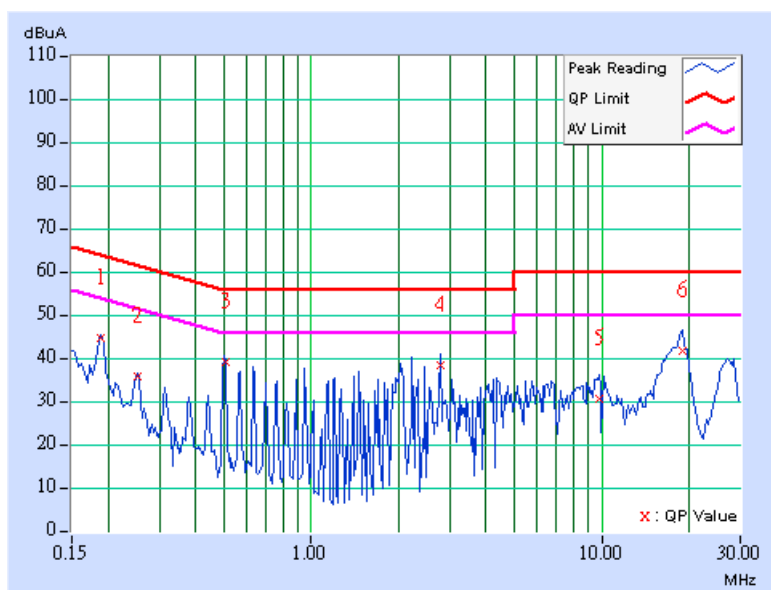

EUT TEST CONDITION		MEASUREMENT DETAIL	
CHANNEL	Channel 1	PHASE	Line 2
MODULATION TYPE	BPSK	6dB BANDWIDTH	9 kHz
TRANSFER RATE	15Mbps	INPUT POWER (SYSTEM)	120Vac, 60 Hz
ENVIRONMENTAL CONDITIONS	22deg. C, 60%RH, 991hPa	TESTED BY	Dean Wang

No	Freq. [MHz]	Corr. Factor (dB)	Reading Value [dB (uV)]		Emission Level [dB (uV)]		Limit [dB (uV)]		Margin (dB)	
			Q.P.	AV.	Q.P.	AV.	Q.P.	AV.	Q.P.	AV.
			1	0.189	0.10	48.46	-	48.56	-	64.08
2	0.252	0.10	40.95	-	41.05	-	61.71	51.71	-20.66	-
3	0.502	0.12	39.43	-	39.55	-	56.00	46.00	-16.45	-
4	2.531	0.24	38.73	-	38.97	-	56.00	46.00	-17.03	-
5	9.070	0.41	30.21	-	30.62	-	60.00	50.00	-29.38	-
6	18.586	0.54	41.85	-	42.39	-	60.00	50.00	-17.61	-

- REMARKS:**
1. Q.P. and AV. are abbreviations of quasi-peak and average individually.
 2. "-": The Quasi-peak reading value also meets average limit and measurement with the average detector is unnecessary.
 3. The emission levels of other frequencies were very low against the limit.
 4. Margin value = Emission level - Limit value
 5. Correction factor = Insertion loss + Cable loss
 6. Emission Level = Correction Factor + Reading Value.

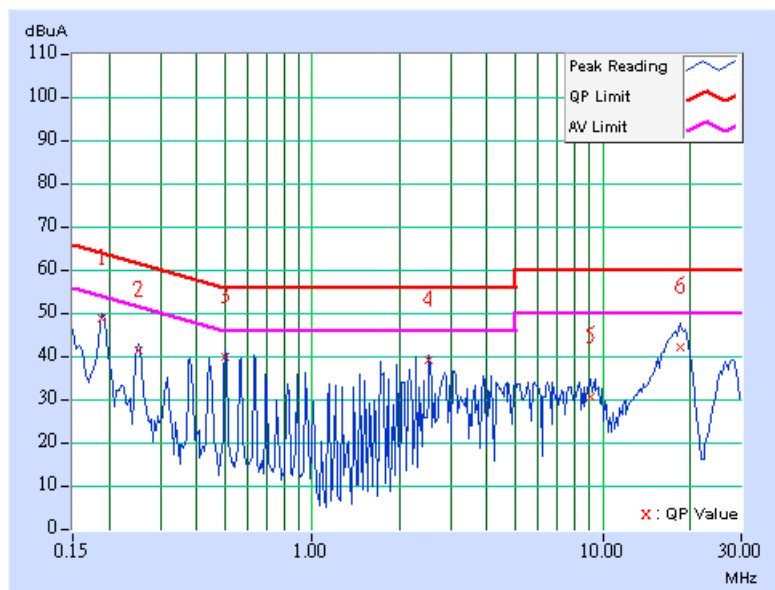

EUT TEST CONDITION		MEASUREMENT DETAIL	
CHANNEL	Channel 4	PHASE	Line 1
MODULATION TYPE	BPSK	6dB BANDWIDTH	9 kHz
TRANSFER RATE	15Mbps	INPUT POWER (SYSTEM)	120Vac, 60 Hz
ENVIRONMENTAL CONDITIONS	22deg. C, 60%RH, 991hPa	TESTED BY	Dean Wang

No	Freq. [MHz]	Corr. Factor (dB)	Reading Value [dB (uV)]		Emission Level [dB (uV)]		Limit [dB (uV)]		Margin (dB)	
			Q.P.	AV.	Q.P.	AV.	Q.P.	AV.	Q.P.	AV.
1	0.189	0.10	44.14	-	44.24	-	64.08	54.08	-19.84	-
2	0.252	0.10	35.24	-	35.34	-	61.71	51.71	-26.37	-
3	0.502	0.10	38.67	-	38.77	-	56.00	46.00	-17.23	-
4	2.219	0.23	38.74	-	38.97	-	56.00	46.00	-17.03	-
5	9.523	0.33	30.11	-	30.44	-	60.00	50.00	-29.56	-
6	18.441	0.54	39.07	-	39.61	-	60.00	50.00	-20.39	-

- REMARKS:**
1. Q.P. and AV. are abbreviations of quasi-peak and average individually.
 2. "-": The Quasi-peak reading value also meets average limit and measurement with the average detector is unnecessary.
 3. The emission levels of other frequencies were very low against the limit.
 4. Margin value = Emission level - Limit value
 5. Correction factor = Insertion loss + Cable loss
 6. Emission Level = Correction Factor + Reading Value.

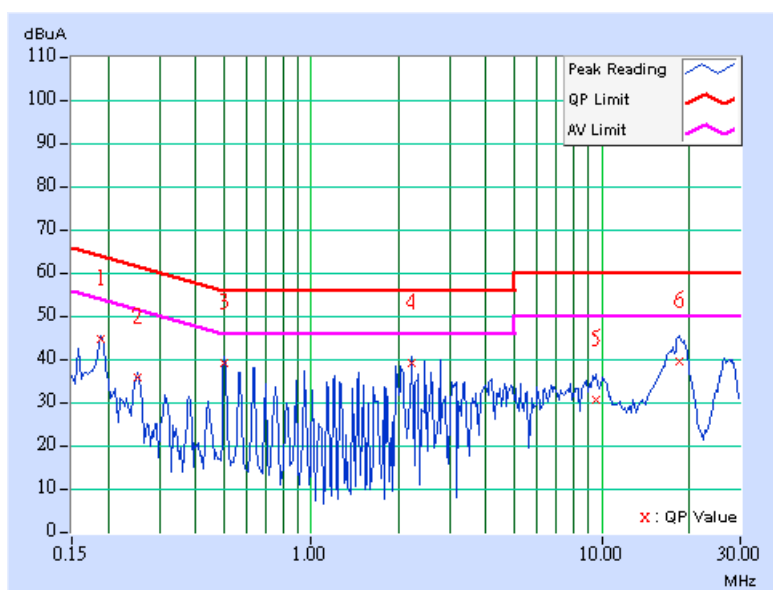

EUT TEST CONDITION		MEASUREMENT DETAIL	
CHANNEL	Channel 4	PHASE	Line 2
MODULATION TYPE	BPSK	6dB BANDWIDTH	9 kHz
TRANSFER RATE	15Mbps	INPUT POWER (SYSTEM)	120Vac, 60 Hz
ENVIRONMENTAL CONDITIONS	22deg. C, 60%RH, 991hPa	TESTED BY	Dean Wang

No	Freq. [MHz]	Corr. Factor (dB)	Reading Value [dB (uV)]		Emission Level [dB (uV)]		Limit [dB (uV)]		Margin (dB)	
			Q.P.	AV.	Q.P.	AV.	Q.P.	AV.	Q.P.	AV.
			1	0.189	0.10	48.50	-	48.60	-	64.08
2	0.252	0.10	40.97	-	41.07	-	61.71	51.71	-20.64	-
3	0.505	0.12	39.52	-	39.64	-	56.00	46.00	-16.36	-
4	2.211	0.23	38.44	-	38.67	-	56.00	46.00	-17.33	-
5	9.078	0.41	31.57	-	31.98	-	60.00	50.00	-28.02	-
6	18.621	0.55	42.89	-	43.44	-	60.00	50.00	-16.56	-

- REMARKS:**
1. Q.P. and AV. are abbreviations of quasi-peak and average individually.
 2. "-": The Quasi-peak reading value also meets average limit and measurement with the average detector is unnecessary.
 3. The emission levels of other frequencies were very low against the limit.
 4. Margin value = Emission level - Limit value
 5. Correction factor = Insertion loss + Cable loss
 6. Emission Level = Correction Factor + Reading Value.

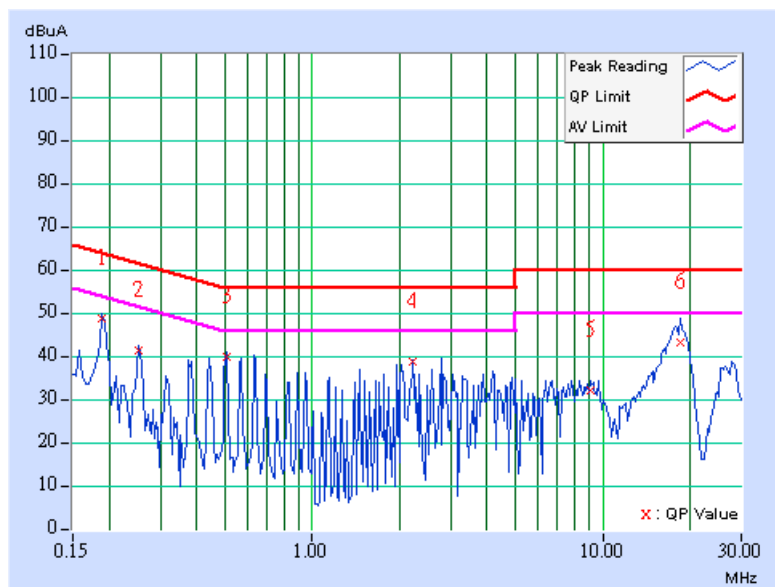

EUT TEST CONDITION		MEASUREMENT DETAIL	
CHANNEL	Channel 7	PHASE	Line 1
MODULATION TYPE	BPSK	6dB BANDWIDTH	9 kHz
TRANSFER RATE	15Mbps	INPUT POWER (SYSTEM)	120Vac, 60 Hz
ENVIRONMENTAL CONDITIONS	22deg. C, 60%RH, 991hPa	TESTED BY	Dean Wang

No	Freq. [MHz]	Corr. Factor [dB]	Reading Value [dB (uV)]		Emission Level [dB (uV)]		Limit [dB (uV)]		Margin (dB)	
			Q.P.	AV.	Q.P.	AV.	Q.P.	AV.	Q.P.	AV.
1	0.189	0.10	43.95	-	44.05	-	64.08	54.08	-20.03	-
2	0.252	0.10	35.08	-	35.18	-	61.71	51.71	-26.53	-
3	0.502	0.10	38.95	-	39.05	-	56.00	46.00	-16.95	-
4	2.271	0.23	38.80	-	39.03	-	56.00	46.00	-16.97	-
5	9.586	0.33	33.22	-	33.55	-	60.00	50.00	-26.45	-
6	18.648	0.55	40.38	-	40.93	-	60.00	50.00	-19.07	-

- REMARKS:**
1. Q.P. and AV. are abbreviations of quasi-peak and average individually.
 2. "-": The Quasi-peak reading value also meets average limit and measurement with the average detector is unnecessary.
 3. The emission levels of other frequencies were very low against the limit.
 4. Margin value = Emission level - Limit value
 5. Correction factor = Insertion loss + Cable loss
 6. Emission Level = Correction Factor + Reading Value.

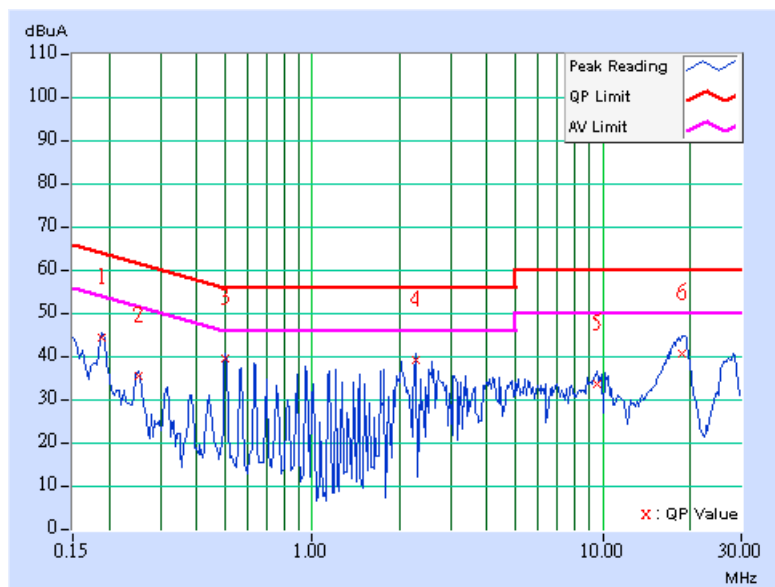

EUT TEST CONDITION		MEASUREMENT DETAIL	
CHANNEL	Channel 7	PHASE	Line 2
MODULATION TYPE	BPSK	6dB BANDWIDTH	9 kHz
TRANSFER RATE	15Mbps	INPUT POWER (SYSTEM)	120Vac, 60 Hz
ENVIRONMENTAL CONDITIONS	22deg. C, 60%RH, 991hPa	TESTED BY	Dean Wang

No	Freq. [MHz]	Corr. Factor (dB)	Reading Value [dB (uV)]		Emission Level [dB (uV)]		Limit [dB (uV)]		Margin (dB)	
			Q.P.	AV.	Q.P.	AV.	Q.P.	AV.	Q.P.	AV.
			1	0.189	0.10	48.44	-	48.54	-	64.08
2	0.252	0.10	40.95	-	41.05	-	61.71	51.71	-20.66	-
3	0.507	0.12	39.54	-	39.66	-	56.00	46.00	-16.34	-
4	1.962	0.22	38.22	-	38.44	-	56.00	46.00	-17.56	-
5	8.875	0.40	30.43	-	30.83	-	60.00	50.00	-29.17	-
6	18.563	0.54	41.32	-	41.86	-	60.00	50.00	-18.14	-

- REMARKS:**
1. Q.P. and AV. are abbreviations of quasi-peak and average individually.
 2. "-": The Quasi-peak reading value also meets average limit and measurement with the average detector is unnecessary.
 3. The emission levels of other frequencies were very low against the limit.
 4. Margin value = Emission level - Limit value
 5. Correction factor = Insertion loss + Cable loss
 6. Emission Level = Correction Factor + Reading Value.

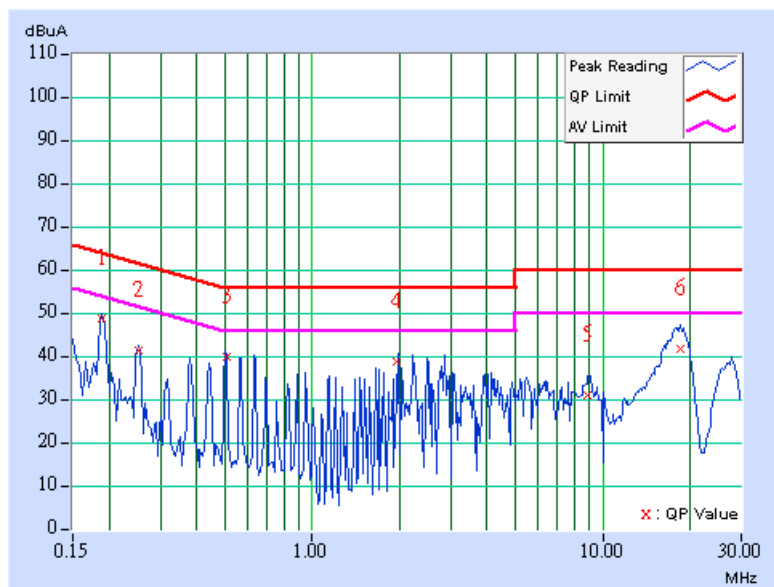

4.2 RADIATED EMISSION MEASUREMENT

4.2.1 LIMITS OF RADIATED EMISSION MEASUREMENT

Emissions radiated outside of the specified bands, shall be according to the general radiated limits in 15.209 as following:

FREQUENCIES (MHz)	FIELD STRENGTH (microvolts/meter)	MEASUREMENT DISTANCE (meters)
0.009 ~ 0.490	2400 / F(kHz)	300
0.490 ~ 1.705	24000 / F(kHz)	30
1.705 ~ 30.0	30	30
30 ~ 88	100	3
88 ~ 216	150	3
216 ~ 960	200	3
Above 960	500	3

NOTE:

1. The lower limit shall apply at the transition frequencies.
2. Emission level (dBuV/m) = 20 log Emission level (uV/m).
3. As shown in 15.35(b), for frequencies above 1000MHz, the field strength limits are based on average detector, however, the peak field strength of any emission shall not exceed the maximum permitted average limits, specified above by more than 20dB under any condition of modulation.

4.2.2 TEST INSTRUMENTS

DESCRIPTION & MANUFACTURER	MODEL NO.	SERIAL NO.	CALIBRATED UNTIL
Test Receiver ROHDE & SCHWARZ	ESIB7	100212	May. 08, 2007
Spectrum Analyzer ROHDE & SCHWARZ	FSP40	100269	Aug. 07, 2007
BILOG Antenna SCHWARZBECK	VULB9168	9168-153	Jan. 04, 2008
HORN Antenna SCHWARZBECK	BBHA 9120 D	9120D-563	Jul. 26, 2007
HORN Antenna SCHWARZBECK	BBHA 9170	BBHA9170242	Jan. 16, 2008
Preamplifier Agilent	8449B	3008A01911	Sep. 13, 2007
Preamplifier Agilent	8447D	2944A10638	Dec. 20, 2007
RF signal cable HUBER+SUHNNER	SUCOFLEX 104	218188/218189	Nov. 14, 2007
RF signal cable Worken	8D-FB	Cable-HYCH9-01	Mar. 08, 2007
Software	ADT_Radiated_V7.6	NA	NA
Antenna Tower EMCO	2070/2080	512.835.4684	NA
Turn Table EMCO	2087-2.03	NA	NA
Antenna Tower & Turn Table Controller EMCO	2090	NA	NA

- NOTE:**
1. The calibration interval of the above test instruments is 12 months and the calibrations are traceable to NML/ROC and NIST/USA.
 2. The test was performed in HwaYa Chamber 9.
 3. The horn antenna and HP preamplifier (model: 8449B) are used only for the measurement of emission frequency above 1GHz if tested.
 4. The IC Site Registration No. is IC4924A-9.

4.2.3 TEST PROCEDURES

- a. The EUT was placed on the top of a rotating table 0.8 meters above the ground at a 3 meters semi-anechoic chamber. The table was rotated 360 degrees to determine the position of the highest radiation.
- b. The EUT was set 3 meters away from the interference-receiving antenna, which was mounted on the top of a variable-height antenna tower.
- c. The antenna is a broadband antenna, and its height is varied from one meter to four meters above the ground to determine the maximum value of the field strength. Both horizontal and vertical polarizations of the antenna are set to make the measurement.
- d. For each suspected emission, the EUT was arranged to its worst case and then the antenna was tuned to heights from 1 meter to 4 meters and the rotatable table was turned from 0 degrees to 360 degrees to find the maximum reading.
- e. The test-receiver system was set to Peak Detect Function and Specified Bandwidth with Maximum Hold Mode.
- f. If the emission level of the EUT in peak mode was lower than the limit specified, then testing could be stopped and the peak values of the EUT would be reported. Otherwise the emissions would be re-tested one by one using peak, quasi-peak or average method as specified and then reported in a data sheet.

NOTE:

1. The resolution bandwidth and video bandwidth of test receiver/spectrum analyzer is 120kHz for Peak detection (PK) and Quasi-peak detection (QP) at frequency below 1GHz.
2. The resolution bandwidth of test receiver/spectrum analyzer is 1 MHz and video bandwidth is 3MHz for Peak detection at frequency above 1GHz.
3. The resolution bandwidth of test receiver/spectrum analyzer is 1MHz and the video bandwidth is 10Hz for Average detection (AV) at frequency above 1GHz.

4.2.4 DEVIATION FROM TEST STANDARD

No deviation

4.2.5 TEST SETUP

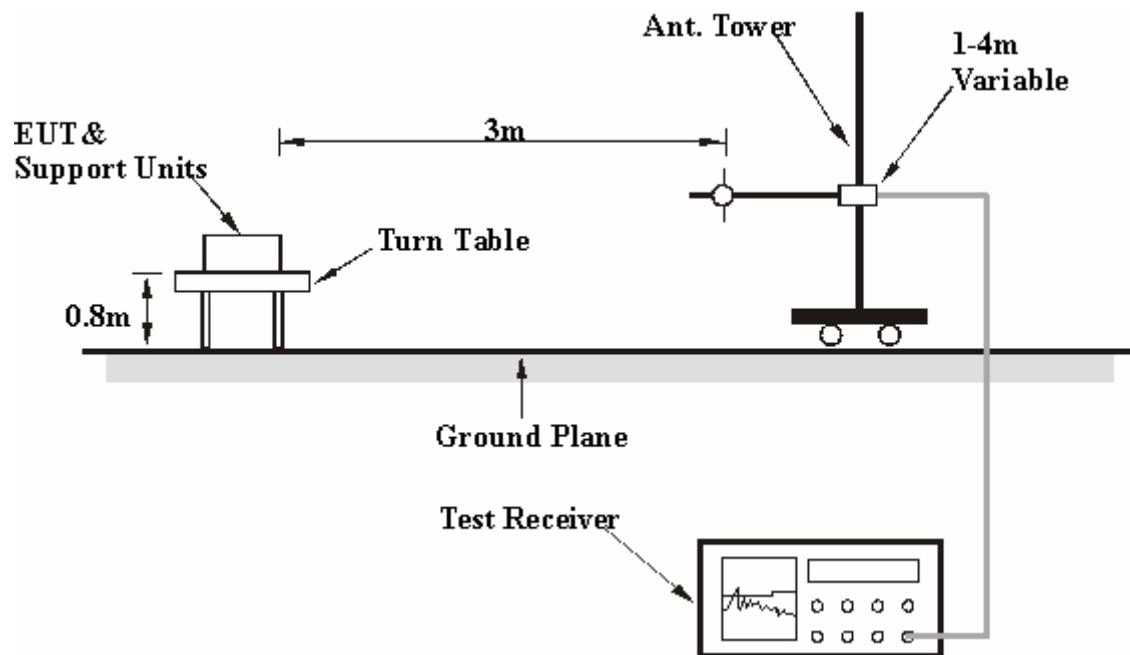

For the actual test configuration, please refer to the related item – Photographs of the Test Configuration.

4.2.6 EUT OPERATING CONDITIONS

Same as item 4.1.6.



4.2.7 TEST RESULTS

BELOW 1GHz WORST-CASE DATA: 802.11g OFDM MODULATION: DUAL TX:

EUT TEST CONDITION		MEASUREMENT DETAIL	
CHANNEL	Channel 1	FREQUENCY RANGE	Below 1000MHz
MODULATION TYPE	BPSK	INPUT POWER (SYSTEM)	120Vac, 60 Hz
TRANSFER RATE	6Mbps	DETECTOR FUNCTION	Quasi-Peak
ENVIRONMENTAL CONDITIONS	23deg. C, 69%RH, 991hPa	TESTED BY	Lori Chiu

ANTENNA POLARITY & TEST DISTANCE: HORIZONTAL AT 3 M								
No.	Freq. (MHz)	Emission Level (dBuV/m)	Limit (dBuV/m)	Margin (dB)	Antenna Height (m)	Table Angle (Degree)	Raw Value (dBuV)	Correction Factor (dB/m)
1	199.05	36.06 QP	43.50	-7.44	1.00 H	103	25.67	10.40
2	399.31	39.91 QP	46.00	-6.09	1.00 H	55	24.22	15.69
3	500.42	38.66 QP	46.00	-7.34	2.00 H	31	19.90	18.76
4	599.58	41.27 QP	46.00	-4.73	1.00 H	232	20.18	21.09
5	681.24	38.56 QP	46.00	-7.44	1.00 H	235	16.73	21.83
6	811.50	38.16 QP	46.00	-7.84	1.00 H	184	13.68	24.48
7	850.39	38.22 QP	46.00	-7.78	1.00 H	133	13.37	24.85
8	951.49	37.63 QP	46.00	-8.37	1.50 H	79	11.90	25.73

ANTENNA POLARITY & TEST DISTANCE: VERTICAL AT 3 M								
No.	Freq. (MHz)	Emission Level (dBuV/m)	Limit (dBuV/m)	Margin (dB)	Antenna Height (m)	Table Angle (Degree)	Raw Value (dBuV)	Correction Factor (dB/m)
1	55.18	38.21 QP	40.00	-1.79	1.00 V	10	24.74	13.47
2	105.73	40.28 QP	43.50	-3.22	1.50 V	307	30.44	9.84
3	199.05	41.96 QP	43.50	-1.54	1.00 V	55	31.57	10.40
4	249.60	44.52 QP	46.00	-1.48	1.00 V	298	31.98	12.54
5	399.31	40.45 QP	46.00	-5.55	1.00 V	199	24.75	15.69
6	500.42	40.45 QP	46.00	-5.55	1.00 V	196	21.68	18.76
7	599.58	43.93 QP	46.00	-2.07	1.50 V	178	22.84	21.09

- REMARKS:**
1. Emission level(dBuV/m)=Raw Value(dBuV) + Correction Factor(dB/m)
 2. Correction Factor(dB/m) = Antenna Factor (dB/m) + Cable Factor (dB)
 3. The other emission levels were very low against the limit.
 4. Margin value = Emission level – Limit value.

DRAFT 802.11n (20MHz) OFDM MODULATION: DUAL TX:

EUT TEST CONDITION		MEASUREMENT DETAIL	
CHANNEL	Channel 1	FREQUENCY RANGE	Below 1000MHz
MODULATION TYPE	BPSK	INPUT POWER (SYSTEM)	120Vac, 60 Hz
TRANSFER RATE	7.2Mbps	DETECTOR FUNCTION	Quasi-Peak
ENVIRONMENTAL CONDITIONS	23deg. C, 69%RH, 991hPa	TESTED BY	Lori Chiu

ANTENNA POLARITY & TEST DISTANCE: HORIZONTAL AT 3 M								
No.	Freq. (MHz)	Emission Level (dBuV/m)	Limit (dBuV/m)	Margin (dB)	Antenna Height (m)	Table Angle (Degree)	Raw Value (dBuV)	Correction Factor (dB/m)
1	199.05	36.90 QP	43.50	-6.60	1.00 H	85	26.50	10.40
2	399.31	38.28 QP	46.00	-7.72	1.00 H	46	22.58	15.69
3	500.42	38.60 QP	46.00	-7.40	2.00 H	223	19.84	18.76
4	599.58	40.66 QP	46.00	-5.34	1.00 H	100	19.57	21.09
5	681.24	38.61 QP	46.00	-7.39	1.00 H	232	16.78	21.83
6	811.50	38.09 QP	46.00	-7.91	1.00 H	211	13.62	24.48
7	850.39	37.58 QP	46.00	-8.42	1.00 H	100	12.73	24.85

ANTENNA POLARITY & TEST DISTANCE: VERTICAL AT 3 M								
No.	Freq. (MHz)	Emission Level (dBuV/m)	Limit (dBuV/m)	Margin (dB)	Antenna Height (m)	Table Angle (Degree)	Raw Value (dBuV)	Correction Factor (dB/m)
1	55.18	36.88 QP	40.00	-3.12	1.00 V	211	23.41	13.47
2	105.73	39.91 QP	43.50	-3.59	1.50 V	292	30.07	9.84
3	199.05	40.10 QP	43.50	-3.40	1.00 V	70	29.70	10.40
4	249.60	43.33 QP	46.00	-2.67	1.00 V	304	30.79	12.54
5	399.31	41.04 QP	46.00	-4.96	1.00 V	172	25.34	15.69
6	500.42	39.73 QP	46.00	-6.27	1.00 V	166	20.96	18.76
7	599.58	44.44 QP	46.00	-1.56	1.50 V	181	23.35	21.09
8	850.39	39.51 QP	46.00	-6.49	1.00 V	187	14.66	24.85
9	951.49	39.01 QP	46.00	-6.99	1.00 V	187	13.28	25.73

- REMARKS:**
1. Emission level(dBuV/m)=Raw Value(dBuV) + Correction Factor(dB/m)
 2. Correction Factor(dB/m) = Antenna Factor (dB/m) + Cable Factor (dB)
 3. The other emission levels were very low against the limit.
 4. Margin value = Emission level – Limit value.

DRAFT 802.11n (40MHz) OFDM MODULATION: DUAL TX:

EUT TEST CONDITION		MEASUREMENT DETAIL	
CHANNEL	Channel 1	FREQUENCY RANGE	Below 1000MHz
MODULATION TYPE	BPSK	INPUT POWER (SYSTEM)	120Vac, 60 Hz
TRANSFER RATE	15Mbps	DETECTOR FUNCTION	Quasi-Peak
ENVIRONMENTAL CONDITIONS	23deg. C, 69%RH, 991hPa	TESTED BY	Lori Chiu

ANTENNA POLARITY & TEST DISTANCE: HORIZONTAL AT 3 M								
No.	Freq. (MHz)	Emission Level (dBuV/m)	Limit (dBuV/m)	Margin (dB)	Antenna Height (m)	Table Angle (Degree)	Raw Value (dBuV)	Correction Factor (dB/m)
1	399.31	38.58 QP	46.00	-7.42	1.00 H	52	22.89	15.69
2	500.42	38.51 QP	46.00	-7.49	2.00 H	46	19.74	18.76
3	599.58	43.87 QP	46.00	-2.13	1.50 H	10	22.78	21.09
4	681.24	38.51 QP	46.00	-7.49	1.00 H	232	16.68	21.83
5	811.50	38.02 QP	46.00	-7.98	1.00 H	199	13.54	24.48
6	850.39	38.02 QP	46.00	-7.98	1.00 H	103	13.17	24.85

ANTENNA POLARITY & TEST DISTANCE: VERTICAL AT 3 M								
No.	Freq. (MHz)	Emission Level (dBuV/m)	Limit (dBuV/m)	Margin (dB)	Antenna Height (m)	Table Angle (Degree)	Raw Value (dBuV)	Correction Factor (dB/m)
1	55.18	36.42 QP	40.00	-3.58	1.50 V	10	22.95	13.47
2	105.73	40.68 QP	43.50	-2.82	1.50 V	307	30.84	9.84
3	199.05	40.78 QP	43.50	-2.72	1.00 V	142	30.38	10.40
4	249.60	43.80 QP	46.00	-2.20	1.00 V	313	31.26	12.54
5	399.31	40.76 QP	46.00	-5.24	1.00 V	208	25.07	15.69
6	500.42	39.26 QP	46.00	-6.74	1.00 V	199	20.50	18.76
7	599.58	43.90 QP	46.00	-2.10	1.50 V	172	22.82	21.09
8	850.39	39.40 QP	46.00	-6.60	1.00 V	181	14.55	24.85
9	951.49	39.01 QP	46.00	-6.99	1.00 V	196	13.28	25.73

- REMARKS:**
1. Emission level(dBuV/m)=Raw Value(dBuV) + Correction Factor(dB/m)
 2. Correction Factor(dB/m) = Antenna Factor (dB/m) + Cable Factor (dB)
 3. The other emission levels were very low against the limit.
 4. Margin value = Emission level – Limit value.

802.11b DSSS MODULATION: DUAL TX:

EUT TEST CONDITION		MEASUREMENT DETAIL	
CHANNEL	Channel 1	FREQUENCY RANGE	1 ~ 25GHz
MODULATION TYPE	DBPSK	INPUT POWER (SYSTEM)	120Vac, 60 Hz
TRANSFER RATE	1Mbps	DETECTOR FUNCTION	Peak(PK) Average (AV)
ENVIRONMENTAL CONDITIONS	23deg. C, 69%RH, 991hPa	TESTED BY	Match Tsui

ANTENNA POLARITY & TEST DISTANCE: HORIZONTAL AT 3 M								
No.	Freq. (MHz)	Emission Level (dBuV/m)	Limit (dBuV/m)	Margin (dB)	Antenna Height (m)	Table Angle (Degree)	Raw Value (dBuV)	Correction Factor (dB/m)
1	2390.00	53.55 PK	74.00	-20.45	1.22 H	67	22.34	31.21
2	2390.00	43.81 AV	54.00	-10.19	1.22 H	67	12.60	31.21
3	*2412.00	101.07 PK			1.22 H	67	69.87	31.20
4	*2412.00	96.67 AV			1.22 H	67	65.47	31.20
5	4824.00	53.89 PK	74.00	-20.11	1.55 H	261	17.46	36.42
6	4824.00	52.40 AV	54.00	-1.60	1.55 H	261	15.98	36.42
7	7236.00	56.26 PK	74.00	-17.74	1.44 H	216	13.35	42.92
8	7236.00	46.78 AV	54.00	-7.22	1.44 H	216	3.87	42.92

ANTENNA POLARITY & TEST DISTANCE: VERTICAL AT 3 M								
No.	Freq. (MHz)	Emission Level (dBuV/m)	Limit (dBuV/m)	Margin (dB)	Antenna Height (m)	Table Angle (Degree)	Raw Value (dBuV)	Correction Factor (dB/m)
1	2390.00	54.03 PK	74.00	-19.97	1.20 V	350	22.82	31.21
2	2390.00	44.83 AV	54.00	-9.17	1.20 V	350	13.62	31.21
3	*2412.00	112.54 PK			1.38 V	164	81.34	31.20
4	*2412.00	108.04 AV			1.38 V	164	76.84	31.20
5	3216.00	45.44 PK	74.00	-28.56	1.00 V	273	13.09	32.35
6	3216.00	38.45 AV	54.00	-15.55	1.00 V	273	6.10	32.35
7	4824.00	52.78 PK	74.00	-21.22	1.26 V	201	16.35	36.42
8	4824.00	50.00 AV	54.00	-4.00	1.26 V	201	13.57	36.42
9	7236.00	56.03 PK	74.00	-17.97	1.54 V	91	13.12	42.92
10	7236.00	47.60 AV	54.00	-6.40	1.54 V	91	4.69	42.92

- REMARKS:**
1. Emission level (dBuV/m) = Raw Value (dBuV) + Correction Factor (dB/m).
 2. Correction Factor (dB/m) = Antenna Factor (dB/m) + Cable Factor (dB).
 3. The other emission levels were very low against the limit.
 4. Margin value = Emission level – Limit value.
 5. The limit value is defined as per 15.247.
 6. “ * “: Fundamental frequency.

EUT TEST CONDITION		MEASUREMENT DETAIL	
CHANNEL	Channel 6	FREQUENCY RANGE	1 ~ 25GHz
MODULATION TYPE	DBPSK	INPUT POWER (SYSTEM)	120Vac, 60 Hz
TRANSFER RATE	1Mbps	DETECTOR FUNCTION	Peak(PK) Average (AV)
ENVIRONMENTAL CONDITIONS	23deg. C, 69%RH, 991hPa	TESTED BY	Match Tsui

ANTENNA POLARITY & TEST DISTANCE: HORIZONTAL AT 3 M								
No.	Freq. (MHz)	Emission Level (dBuV/m)	Limit (dBuV/m)	Margin (dB)	Antenna Height (m)	Table Angle (Degree)	Raw Value (dBuV)	Correction Factor (dB/m)
1	*2437.00	104.34 PK			1.34 H	82	73.12	31.22
2	*2437.00	99.66 AV			1.34 H	82	68.44	31.22
3	4874.00	48.87 PK	74.00	-25.13	1.03 H	360	12.29	36.58
4	4874.00	43.87 AV	54.00	-10.13	1.03 H	360	7.29	36.58
5	7311.00	58.50 PK	74.00	-15.50	1.45 H	49	15.48	43.02
6	7311.00	50.19 AV	54.00	-3.81	1.45 H	49	7.17	43.02

ANTENNA POLARITY & TEST DISTANCE: VERTICAL AT 3 M								
No.	Freq. (MHz)	Emission Level (dBuV/m)	Limit (dBuV/m)	Margin (dB)	Antenna Height (m)	Table Angle (Degree)	Raw Value (dBuV)	Correction Factor (dB/m)
1	*2437.00	114.85 PK			1.17 V	213	83.63	31.22
2	*2437.00	109.88 AV			1.17 V	213	78.66	31.22
3	2483.50	55.94 PK	74.00	-18.06	1.17 V	213	24.71	31.24
4	2483.50	45.76 AV	54.00	-8.24	1.17 V	213	14.53	31.24
5	4874.00	53.85 PK	74.00	-20.15	1.00 V	20	17.27	36.58
6	4874.00	51.10 AV	54.00	-2.90	1.00 V	20	14.52	36.58
7	7311.00	56.39 PK	74.00	-17.61	1.37 V	237	13.38	43.02
8	7311.00	48.55 AV	54.00	-5.45	1.37 V	237	5.54	43.02

- REMARKS:**
1. Emission level (dBuV/m) = Raw Value (dBuV) + Correction Factor (dB/m).
 2. Correction Factor (dB/m) = Antenna Factor (dB/m) + Cable Factor (dB).
 3. The other emission levels were very low against the limit.
 4. Margin value = Emission level – Limit value.
 5. The limit value is defined as per 15.247.
 6. “ * “: Fundamental frequency.

EUT TEST CONDITION		MEASUREMENT DETAIL	
CHANNEL	Channel 11	FREQUENCY RANGE	1 ~ 25GHz
MODULATION TYPE	DBPSK	INPUT POWER (SYSTEM)	120Vac, 60 Hz
TRANSFER RATE	1Mbps	DETECTOR FUNCTION	Peak(PK) Average (AV)
ENVIRONMENTAL CONDITIONS	23deg. C, 69%RH, 991hPa	TESTED BY	Match Tsui

ANTENNA POLARITY & TEST DISTANCE: HORIZONTAL AT 3 M								
No.	Freq. (MHz)	Emission Level (dBuV/m)	Limit (dBuV/m)	Margin (dB)	Antenna Height (m)	Table Angle (Degree)	Raw Value (dBuV)	Correction Factor (dB/m)
1	*2462.00	104.17 PK			1.20 H	105	72.95	31.22
2	*2462.00	100.20 AV			1.20 H	105	68.98	31.22
3	2487.00	55.67 PK	74.00	-18.33	1.20 H	105	24.44	31.23
4	2487.00	46.08 AV	54.00	-7.92	1.20 H	105	14.85	31.23
5	4924.00	49.71 PK	74.00	-24.29	1.65 H	128	13.07	36.63
6	4924.00	45.49 AV	54.00	-8.51	1.65 H	128	8.85	36.63
7	7386.00	58.29 PK	74.00	-15.71	1.50 H	225	15.26	43.03
8	7386.00	51.47 AV	54.00	-2.53	1.50 H	225	8.44	43.03

ANTENNA POLARITY & TEST DISTANCE: VERTICAL AT 3 M								
No.	Freq. (MHz)	Emission Level (dBuV/m)	Limit (dBuV/m)	Margin (dB)	Antenna Height (m)	Table Angle (Degree)	Raw Value (dBuV)	Correction Factor (dB/m)
1	*2462.00	115.08 PK			1.11 V	153	83.86	31.22
2	*2462.00	110.61 AV			1.11 V	153	79.39	31.22
3	2487.00	61.48 PK	74.00	-12.52	1.10 V	157	30.25	31.23
4	2487.00	51.67 AV	54.00	-2.33	1.10 V	157	20.44	31.23
5	4924.00	50.80 PK	74.00	-23.20	1.14 V	254	14.16	36.63
6	4924.00	47.74 AV	54.00	-6.26	1.14 V	254	11.10	36.63
7	7386.00	57.93 PK	74.00	-16.07	1.85 V	248	14.90	43.03
8	7386.00	49.93 AV	54.00	-4.07	1.85 V	248	6.90	43.03

- REMARKS:**
1. Emission level (dBuV/m) = Raw Value (dBuV) + Correction Factor (dB/m).
 2. Correction Factor (dB/m) = Antenna Factor (dB/m) + Cable Factor (dB).
 3. The other emission levels were very low against the limit.
 4. Margin value = Emission level – Limit value.
 5. The limit value is defined as per 15.247.
 6. “ * “: Fundamental frequency.



802.11g OFDM MODULATION: DUAL TX:

EUT TEST CONDITION		MEASUREMENT DETAIL	
CHANNEL	Channel 1	FREQUENCY RANGE	1 ~ 25GHz
MODULATION TYPE	BPSK	INPUT POWER (SYSTEM)	120Vac, 60 Hz
TRANSFER RATE	6Mbps	DETECTOR FUNCTION	Peak(PK) Average (AV)
ENVIRONMENTAL CONDITIONS	23deg. C, 69%RH, 991hPa	TESTED BY	Match Tsui

ANTENNA POLARITY & TEST DISTANCE: HORIZONTAL AT 3 M								
No.	Freq. (MHz)	Emission Level (dBuV/m)	Limit (dBuV/m)	Margin (dB)	Antenna Height (m)	Table Angle (Degree)	Raw Value (dBuV)	Correction Factor (dB/m)
1	2390.00	56.77 PK	74.00	-17.23	1.48 H	267	25.56	31.21
2	2390.00	44.96 AV	54.00	-9.04	1.48 H	267	13.75	31.21
3	*2412.00	100.35 PK			1.48 H	267	69.15	31.20
4	*2412.00	90.50 AV			1.48 H	267	59.30	31.20
5	4824.00	50.77 PK	74.00	-23.23	1.10 H	1	14.35	36.42
6	4824.00	35.47 AV	54.00	-18.53	1.10 H	1	-0.95	36.42

ANTENNA POLARITY & TEST DISTANCE: VERTICAL AT 3 M								
No.	Freq. (MHz)	Emission Level (dBuV/m)	Limit (dBuV/m)	Margin (dB)	Antenna Height (m)	Table Angle (Degree)	Raw Value (dBuV)	Correction Factor (dB/m)
1	2390.00	72.66 PK	74.00	-1.34	1.12 V	156	41.45	31.21
2	2390.00	51.66 AV	54.00	-2.34	1.12 V	156	20.45	31.21
3	*2412.00	114.00 PK			1.12 V	156	82.80	31.20
4	*2412.00	104.15 AV			1.12 V	156	72.95	31.20
5	4824.00	54.54 PK	74.00	-19.46	1.17 V	147	18.11	36.42
6	4824.00	39.14 AV	54.00	-14.86	1.17 V	147	2.71	36.42

- REMARKS:**
1. Emission level (dBuV/m) = Raw Value (dBuV) + Correction Factor (dB/m).
 2. Correction Factor (dB/m) = Antenna Factor (dB/m) + Cable Factor (dB).
 3. The other emission levels were very low against the limit.
 4. Margin value = Emission level – Limit value.
 5. The limit value is defined as per 15.247.
 6. “ * “: Fundamental frequency.

EUT TEST CONDITION		MEASUREMENT DETAIL	
CHANNEL	Channel 6	FREQUENCY RANGE	1 ~ 25GHz
MODULATION TYPE	BPSK	INPUT POWER (SYSTEM)	120Vac, 60 Hz
TRANSFER RATE	6Mbps	DETECTOR FUNCTION	Peak(PK) Average (AV)
ENVIRONMENTAL CONDITIONS	23deg. C, 69%RH, 991hPa	TESTED BY	Match Tsui

ANTENNA POLARITY & TEST DISTANCE: HORIZONTAL AT 3 M								
No.	Freq. (MHz)	Emission Level (dBuV/m)	Limit (dBuV/m)	Margin (dB)	Antenna Height (m)	Table Angle (Degree)	Raw Value (dBuV)	Correction Factor (dB/m)
1	*2437.00	101.40 PK			1.34 H	300	70.19	31.21
2	*2437.00	90.85 AV			1.34 H	300	59.64	31.21
3	4874.00	45.77 PK	74.00	-28.23	1.00 H	0	9.24	36.53
4	4874.00	34.75 AV	54.00	-19.25	1.00 H	0	-1.78	36.53

ANTENNA POLARITY & TEST DISTANCE: VERTICAL AT 3 M								
No.	Freq. (MHz)	Emission Level (dBuV/m)	Limit (dBuV/m)	Margin (dB)	Antenna Height (m)	Table Angle (Degree)	Raw Value (dBuV)	Correction Factor (dB/m)
1	*2437.00	114.27 PK			1.31 V	167	83.06	31.21
2	*2437.00	104.30 AV			1.31 V	167	73.09	31.21
3	4874.00	53.47 PK	74.00	-20.53	1.07 V	169	16.94	36.53
4	4874.00	37.85 AV	54.00	-16.15	1.07 V	169	1.32	36.53

- REMARKS:**
1. Emission level (dBuV/m) = Raw Value (dBuV) + Correction Factor (dB/m).
 2. Correction Factor (dB/m) = Antenna Factor (dB/m) + Cable Factor (dB).
 3. The other emission levels were very low against the limit.
 4. Margin value = Emission level – Limit value.
 5. The limit value is defined as per 15.247.
 6. “ * “: Fundamental frequency.

EUT TEST CONDITION		MEASUREMENT DETAIL	
CHANNEL	Channel 11	FREQUENCY RANGE	1 ~ 25GHz
MODULATION TYPE	BPSK	INPUT POWER (SYSTEM)	120Vac, 60 Hz
TRANSFER RATE	6Mbps	DETECTOR FUNCTION	Peak(PK) Average (AV)
ENVIRONMENTAL CONDITIONS	23deg. C, 69%RH, 991hPa	TESTED BY	Match Tsui

ANTENNA POLARITY & TEST DISTANCE: HORIZONTAL AT 3 M								
No.	Freq. (MHz)	Emission Level (dBuV/m)	Limit (dBuV/m)	Margin (dB)	Antenna Height (m)	Table Angle (Degree)	Raw Value (dBuV)	Correction Factor (dB/m)
1	*2462.00	100.49 PK			1.35 H	240	69.27	31.22
2	*2462.00	90.96 AV			1.35 H	240	59.74	31.22
3	2483.50	57.87 PK	74.00	-16.13	1.35 H	240	26.64	31.23
4	2483.50	45.60 AV	54.00	-8.40	1.35 H	240	14.37	31.23
5	4924.00	48.80 PK	74.00	-25.20	1.00 H	360	12.17	36.63
6	4924.00	33.49 AV	54.00	-20.51	1.00 H	360	-3.14	36.63

ANTENNA POLARITY & TEST DISTANCE: VERTICAL AT 3 M								
No.	Freq. (MHz)	Emission Level (dBuV/m)	Limit (dBuV/m)	Margin (dB)	Antenna Height (m)	Table Angle (Degree)	Raw Value (dBuV)	Correction Factor (dB/m)
1	*2462.00	114.32 PK			1.10 V	154	83.10	31.22
2	*2462.00	104.62 AV			1.10 V	154	73.40	31.22
3	2483.50	70.37 PK	74.00	-3.63	1.09 V	162	39.14	31.23
4	2483.50	52.01 AV	54.00	-1.99	1.09 V	162	20.78	31.23
5	4924.00	50.32 PK	74.00	-23.68	1.13 V	143	13.68	36.63
6	4924.00	35.74 AV	54.00	-18.26	1.13 V	143	-0.90	36.63

- REMARKS:**
1. Emission level (dBuV/m) = Raw Value (dBuV) + Correction Factor (dB/m).
 2. Correction Factor (dB/m) = Antenna Factor (dB/m) + Cable Factor (dB).
 3. The other emission levels were very low against the limit.
 4. Margin value = Emission level – Limit value.
 5. The limit value is defined as per 15.247.
 6. “ * “: Fundamental frequency.



DRAFT 802.11n (20MHz) OFDM MODULATION: DUAL TX:

EUT TEST CONDITION		MEASUREMENT DETAIL	
CHANNEL	Channel 1	FREQUENCY RANGE	1 ~ 25GHz
MODULATION TYPE	BPSK	INPUT POWER (SYSTEM)	120Vac, 60 Hz
TRANSFER RATE	7.2Mbps	DETECTOR FUNCTION	Peak(PK) Average (AV)
ENVIRONMENTAL CONDITIONS	23deg. C, 69%RH, 991hPa	TESTED BY	Lori Chen

ANTENNA POLARITY & TEST DISTANCE: HORIZONTAL AT 3 M								
No.	Freq. (MHz)	Emission Level (dBuV/m)	Limit (dBuV/m)	Margin (dB)	Antenna Height (m)	Table Angle (Degree)	Raw Value (dBuV)	Correction Factor (dB/m)
1	2390.00	55.22 PK	74.00	-18.78	1.12 H	186	24.01	31.21
2	2390.00	44.31 AV	54.00	-9.69	1.12 H	186	13.10	31.21
3	*2412.00	98.79 PK			1.12 H	185	67.59	31.20
4	*2412.00	88.65 AV			1.12 H	185	57.45	31.20
5	4824.00	47.16 PK	74.00	-26.84	1.06 H	327	10.74	36.42
6	4824.00	33.85 AV	54.00	-20.15	1.06 H	327	-2.57	36.42

ANTENNA POLARITY & TEST DISTANCE: VERTICAL AT 3 M								
No.	Freq. (MHz)	Emission Level (dBuV/m)	Limit (dBuV/m)	Margin (dB)	Antenna Height (m)	Table Angle (Degree)	Raw Value (dBuV)	Correction Factor (dB/m)
1	2390.00	72.08 PK	74.00	-1.92	1.15 V	154	40.87	31.21
2	2390.00	51.98 AV	54.00	-2.02	1.15 V	154	20.77	31.21
3	*2412.00	112.50 PK			1.13 V	219	81.30	31.20
4	*2412.00	102.46 AV			1.13 V	219	71.26	31.20
5	4824.00	48.82 PK	74.00	-25.18	1.47 V	106	12.39	36.42
6	4824.00	34.73 AV	54.00	-19.27	1.47 V	106	-1.70	36.42

- REMARKS:**
1. Emission level (dBuV/m) = Raw Value (dBuV) + Correction Factor (dB/m).
 2. Correction Factor (dB/m) = Antenna Factor (dB/m) + Cable Factor (dB).
 3. The other emission levels were very low against the limit.
 4. Margin value = Emission level – Limit value.
 5. The limit value is defined as per 15.247.
 6. “ * “: Fundamental frequency.



EUT TEST CONDITION		MEASUREMENT DETAIL	
CHANNEL	Channel 6	FREQUENCY RANGE	1 ~ 25GHz
MODULATION TYPE	BPSK	INPUT POWER (SYSTEM)	120Vac, 60 Hz
TRANSFER RATE	7.2Mbps	DETECTOR FUNCTION	Peak(PK) Average (AV)
ENVIRONMENTAL CONDITIONS	23deg. C, 69%RH, 991hPa	TESTED BY	Lori Chen

ANTENNA POLARITY & TEST DISTANCE: HORIZONTAL AT 3 M								
No.	Freq. (MHz)	Emission Level (dBuV/m)	Limit (dBuV/m)	Margin (dB)	Antenna Height (m)	Table Angle (Degree)	Raw Value (dBuV)	Correction Factor (dB/m)
1	*2437.00	100.35 PK			1.17 H	176	69.14	31.21
2	*2437.00	90.11 AV			1.17 H	176	58.90	31.21
3	4874.00	47.97 PK	74.00	-26.03	1.30 H	244	11.44	36.53
4	4874.00	34.58 AV	54.00	-19.42	1.30 H	244	-1.95	36.53

ANTENNA POLARITY & TEST DISTANCE: VERTICAL AT 3 M								
No.	Freq. (MHz)	Emission Level (dBuV/m)	Limit (dBuV/m)	Margin (dB)	Antenna Height (m)	Table Angle (Degree)	Raw Value (dBuV)	Correction Factor (dB/m)
1	*2437.00	114.79 PK			1.14 V	162	83.58	31.21
2	*2437.00	104.51 AV			1.14 V	162	73.30	31.21
3	4874.00	48.59 PK	74.00	-25.41	1.24 V	278	12.06	36.53
4	4874.00	35.17 AV	54.00	-18.83	1.24 V	278	-1.36	36.53

- REMARKS:**
1. Emission level (dBuV/m) = Raw Value (dBuV) + Correction Factor (dB/m).
 2. Correction Factor (dB/m) = Antenna Factor (dB/m) + Cable Factor (dB).
 3. The other emission levels were very low against the limit.
 4. Margin value = Emission level – Limit value.
 5. The limit value is defined as per 15.247.
 6. “ * “: Fundamental frequency.



EUT TEST CONDITION		MEASUREMENT DETAIL	
CHANNEL	Channel 11	FREQUENCY RANGE	1 ~ 25GHz
MODULATION TYPE	BPSK	INPUT POWER (SYSTEM)	120Vac, 60 Hz
TRANSFER RATE	7.2Mbps	DETECTOR FUNCTION	Peak(PK) Average (AV)
ENVIRONMENTAL CONDITIONS	23deg. C, 69%RH, 991hPa	TESTED BY	Lori Chen

ANTENNA POLARITY & TEST DISTANCE: HORIZONTAL AT 3 M								
No.	Freq. (MHz)	Emission Level (dBuV/m)	Limit (dBuV/m)	Margin (dB)	Antenna Height (m)	Table Angle (Degree)	Raw Value (dBuV)	Correction Factor (dB/m)
1	*2462.00	100.42 PK			1.29 H	190	69.20	31.22
2	*2462.00	90.38 AV			1.29 H	190	59.16	31.22
3	2483.50	56.10 PK	74.00	-17.90	1.30 H	190	24.87	31.23
4	2483.50	45.48 AV	54.00	-8.52	1.30 H	190	14.25	31.23
5	4924.00	47.64 PK	74.00	-26.36	1.10 H	276	11.01	36.63
6	4924.00	34.55 AV	54.00	-19.45	1.10 H	276	-2.08	36.63

ANTENNA POLARITY & TEST DISTANCE: VERTICAL AT 3 M								
No.	Freq. (MHz)	Emission Level (dBuV/m)	Limit (dBuV/m)	Margin (dB)	Antenna Height (m)	Table Angle (Degree)	Raw Value (dBuV)	Correction Factor (dB/m)
1	*2462.00	114.82 PK			1.08 V	153	83.60	31.22
2	*2462.00	104.48 AV			1.08 V	153	73.26	31.22
3	2483.50	69.75 PK	74.00	-4.25	1.09 V	158	38.52	31.23
4	2483.50	52.19 AV	54.00	-1.81	1.09 V	158	20.96	31.23
5	4924.00	48.27 PK	74.00	-25.73	1.20 V	195	11.64	36.63
6	4924.00	35.99 AV	54.00	-18.01	1.20 V	195	-0.64	36.63

- REMARKS:**
1. Emission level (dBuV/m) = Raw Value (dBuV) + Correction Factor (dB/m).
 2. Correction Factor (dB/m) = Antenna Factor (dB/m) + Cable Factor (dB).
 3. The other emission levels were very low against the limit.
 4. Margin value = Emission level – Limit value.
 5. The limit value is defined as per 15.247.
 6. “ * “: Fundamental frequency.

DRAFT 802.11n (40MHz) OFDM MODULATION: DUAL TX:

EUT TEST CONDITION		MEASUREMENT DETAIL	
CHANNEL	Channel 1	FREQUENCY RANGE	1 ~ 25GHz
MODULATION TYPE	BPSK	INPUT POWER (SYSTEM)	120Vac, 60 Hz
TRANSFER RATE	15Mbps	DETECTOR FUNCTION	Peak(PK) Average (AV)
ENVIRONMENTAL CONDITIONS	23deg. C, 69%RH, 991hPa	TESTED BY	Lori Chen

ANTENNA POLARITY & TEST DISTANCE: HORIZONTAL AT 3 M								
No.	Freq. (MHz)	Emission Level (dBuV/m)	Limit (dBuV/m)	Margin (dB)	Antenna Height (m)	Table Angle (Degree)	Raw Value (dBuV)	Correction Factor (dB/m)
1	2390.00	54.81 PK	74.00	-19.19	1.14 H	126	23.60	31.21
2	2390.00	44.98 AV	54.00	-9.02	1.14 H	126	13.77	31.21
3	*2422.00	95.44 PK			1.13 H	126	64.23	31.21
4	*2422.00	85.48 AV			1.13 H	126	54.27	31.21
5	4844.00	45.99 PK	74.00	-28.01	1.00 H	15	9.53	36.46
6	4844.00	32.11 AV	54.00	-21.89	1.00 H	15	-4.35	36.46

ANTENNA POLARITY & TEST DISTANCE: VERTICAL AT 3 M								
No.	Freq. (MHz)	Emission Level (dBuV/m)	Limit (dBuV/m)	Margin (dB)	Antenna Height (m)	Table Angle (Degree)	Raw Value (dBuV)	Correction Factor (dB/m)
1	2390.00	67.16 PK	74.00	-6.84	1.14 V	274	35.95	31.21
2	2390.00	52.43 AV	54.00	-1.57	1.14 V	274	21.22	31.21
3	*2422.00	106.97 PK			1.16 V	216	75.76	31.21
4	*2422.00	96.85 AV			1.16 V	216	65.64	31.21
5	4844.00	46.99 PK	74.00	-27.01	1.12 V	160	10.53	36.46
6	4844.00	33.11 AV	54.00	-20.89	1.12 V	160	-3.35	36.46

- REMARKS:**
1. Emission level (dBuV/m) = Raw Value (dBuV) + Correction Factor (dB/m).
 2. Correction Factor (dB/m) = Antenna Factor (dB/m) + Cable Factor (dB).
 3. The other emission levels were very low against the limit.
 4. Margin value = Emission level – Limit value.
 5. The limit value is defined as per 15.247.
 6. “ * “: Fundamental frequency.



EUT TEST CONDITION		MEASUREMENT DETAIL	
CHANNEL	Channel 4	FREQUENCY RANGE	1 ~ 25GHz
MODULATION TYPE	BPSK	INPUT POWER (SYSTEM)	120Vac, 60 Hz
TRANSFER RATE	15Mbps	DETECTOR FUNCTION	Peak(PK) Average (AV)
ENVIRONMENTAL CONDITIONS	23deg. C, 69%RH, 991hPa	TESTED BY	Lori Chen

ANTENNA POLARITY & TEST DISTANCE: HORIZONTAL AT 3 M								
No.	Freq. (MHz)	Emission Level (dBuV/m)	Limit (dBuV/m)	Margin (dB)	Antenna Height (m)	Table Angle (Degree)	Raw Value (dBuV)	Correction Factor (dB/m)
1	*2437.00	97.58 PK			1.18 H	289	66.37	31.21
2	*2437.00	87.77 AV			1.18 H	289	56.56	31.21
3	4874.00	46.76 PK	74.00	-27.24	1.00 H	249	10.23	36.53
4	4874.00	33.52 AV	54.00	-20.48	1.00 H	249	-3.01	36.53

ANTENNA POLARITY & TEST DISTANCE: VERTICAL AT 3 M								
No.	Freq. (MHz)	Emission Level (dBuV/m)	Limit (dBuV/m)	Margin (dB)	Antenna Height (m)	Table Angle (Degree)	Raw Value (dBuV)	Correction Factor (dB/m)
1	*2437.00	108.36 PK			1.14 V	323	77.15	31.21
2	*2437.00	98.29 AV			1.14 V	323	67.08	31.21
3	2483.50	67.32 PK	74.00	-6.68	1.14 V	329	36.09	31.23
4	2483.50	51.30 AV	54.00	-2.70	1.14 V	329	20.07	31.23
5	4874.00	47.87 PK	74.00	-26.13	1.33 V	208	11.34	36.53
6	4874.00	34.90 AV	54.00	-19.10	1.33 V	208	-1.63	36.53

- REMARKS:**
1. Emission level (dBuV/m) = Raw Value (dBuV) + Correction Factor (dB/m).
 2. Correction Factor (dB/m) = Antenna Factor (dB/m) + Cable Factor (dB).
 3. The other emission levels were very low against the limit.
 4. Margin value = Emission level – Limit value.
 5. The limit value is defined as per 15.247.
 6. “ * “: Fundamental frequency.



EUT TEST CONDITION		MEASUREMENT DETAIL	
CHANNEL	Channel 7	FREQUENCY RANGE	1 ~ 25GHz
MODULATION TYPE	BPSK	INPUT POWER (SYSTEM)	120Vac, 60 Hz
TRANSFER RATE	15Mbps	DETECTOR FUNCTION	Peak(PK) Average (AV)
ENVIRONMENTAL CONDITIONS	23deg. C, 69%RH, 991hPa	TESTED BY	Lori Chen

ANTENNA POLARITY & TEST DISTANCE: HORIZONTAL AT 3 M								
No.	Freq. (MHz)	Emission Level (dBuV/m)	Limit (dBuV/m)	Margin (dB)	Antenna Height (m)	Table Angle (Degree)	Raw Value (dBuV)	Correction Factor (dB/m)
1	*2452.00	96.24 PK			1.25 H	301	65.02	31.22
2	*2452.00	86.75 AV			1.25 H	301	55.53	31.22
3	2483.50	56.39 PK	74.00	-17.61	1.25 H	300	25.16	31.23
4	2483.50	45.75 AV	54.00	-8.25	1.25 H	300	14.52	31.23
5	4904.00	46.58 PK	74.00	-27.42	1.07 H	112	9.99	36.59
6	4904.00	33.20 AV	54.00	-20.80	1.07 H	112	-3.39	36.59

ANTENNA POLARITY & TEST DISTANCE: VERTICAL AT 3 M								
No.	Freq. (MHz)	Emission Level (dBuV/m)	Limit (dBuV/m)	Margin (dB)	Antenna Height (m)	Table Angle (Degree)	Raw Value (dBuV)	Correction Factor (dB/m)
1	*2452.00	107.51 PK			1.16 V	9	76.29	31.22
2	*2452.00	98.00 AV			1.16 V	9	66.78	31.22
3	2483.50	68.99 PK	74.00	-5.01	1.16 V	6	37.76	31.23
4	2483.50	52.05 AV	54.00	-1.95	1.16 V	6	20.82	31.23
5	4904.00	47.15 PK	74.00	-26.85	1.42 V	323	10.56	36.59
6	4904.00	34.67 AV	54.00	-19.33	1.42 V	323	-1.92	36.59

- REMARKS:**
1. Emission level (dBuV/m) = Raw Value (dBuV) + Correction Factor (dB/m).
 2. Correction Factor (dB/m) = Antenna Factor (dB/m) + Cable Factor (dB).
 3. The other emission levels were very low against the limit.
 4. Margin value = Emission level – Limit value.
 5. The limit value is defined as per 15.247.
 6. “ * “: Fundamental frequency.



4.3 6dB BANDWIDTH MEASUREMENT

4.3.1 LIMITS OF 6dB BANDWIDTH MEASUREMENT

The minimum of 6dB Bandwidth Measurement is 0.5 MHz.

4.3.2 TEST INSTRUMENTS

DESCRIPTION & MANUFACTURER	MODEL NO.	SERIAL NO.	CALIBRATED UNTIL
SPECTRUM ANALYZER	FSP40	100040	Jun. 07, 2007

NOTE: The calibration interval of the above test instruments is 12 months and the calibrations are traceable to NML/ROC and NIST/USA.

4.3.3 TEST PROCEDURE

The transmitter output was connected to the spectrum analyzer through an attenuator. The bandwidth of the fundamental frequency was measured by spectrum analyzer with 100kHz RBW and 100kHz VBW. The 6dB bandwidth is defined as the total spectrum the power of which is higher than peak power minus 6dB.

4.3.4 DEVIATION FROM TEST STANDARD

No deviation

4.3.5 TEST SETUP

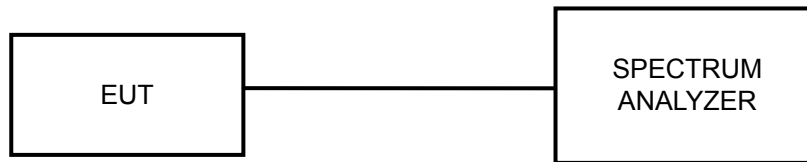

4.3.6 EUT OPERATING CONDITIONS

The software provided by client to enable the EUT under transmission condition continuously at lowest, middle and highest channel frequencies individually.

4.3.7 TEST RESULTS

802.11b DSSS MODULATION:

MODULATION TYPE	DBPSK	TRANSFER RATE	1Mbps
INPUT POWER (SYSTEM)	120Vac, 60 Hz	ENVIRONMENTAL CONDITIONS	25deg.C, 63%RH, 991hPa
TESTED BY	Long Chen		

CHANNEL	CHANNEL FREQUENCY (MHz)	6dB BANDWIDTH (MHz)		MINIMUM LIMIT (MHz)	PASS / FAIL
		CHAIN 0	CHAIN 1		
1	2412	11.12	11.16	0.5	PASS
6	2437	11.08	12.00	0.5	PASS
11	2462	12.04	11.16	0.5	PASS

FOR CHAIN 0: CH 1

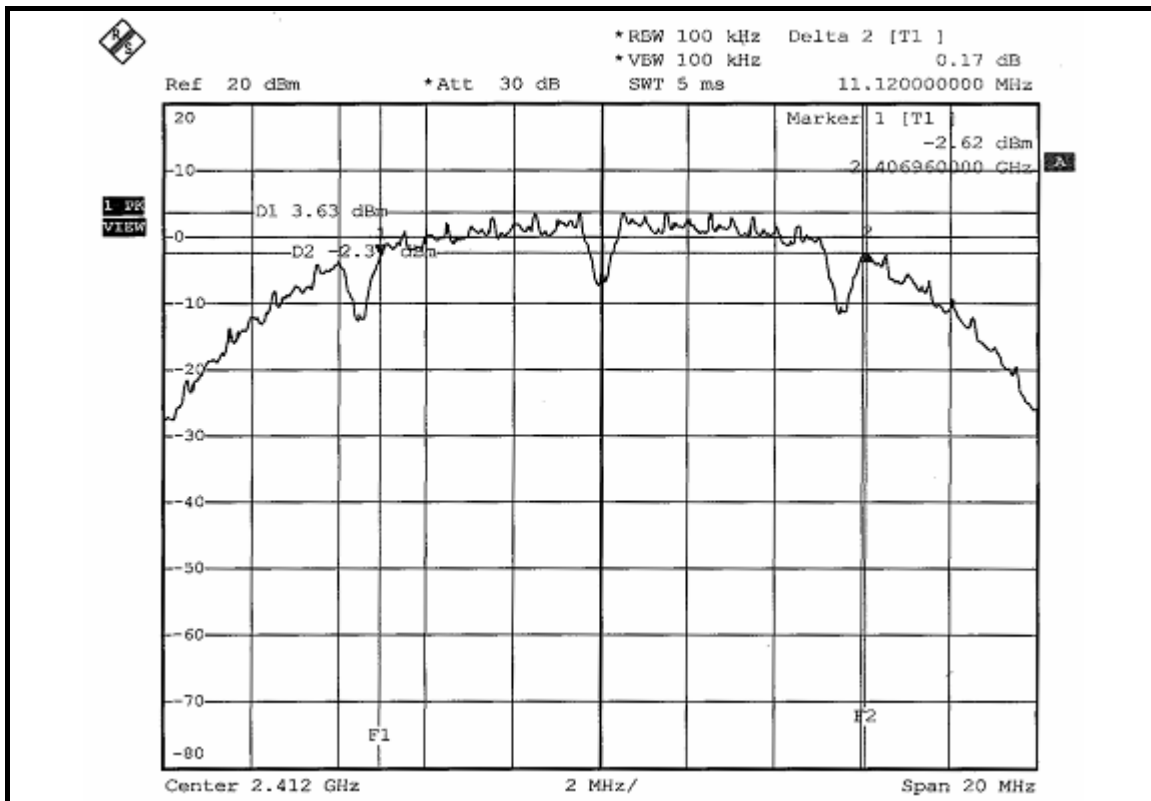

CH 6

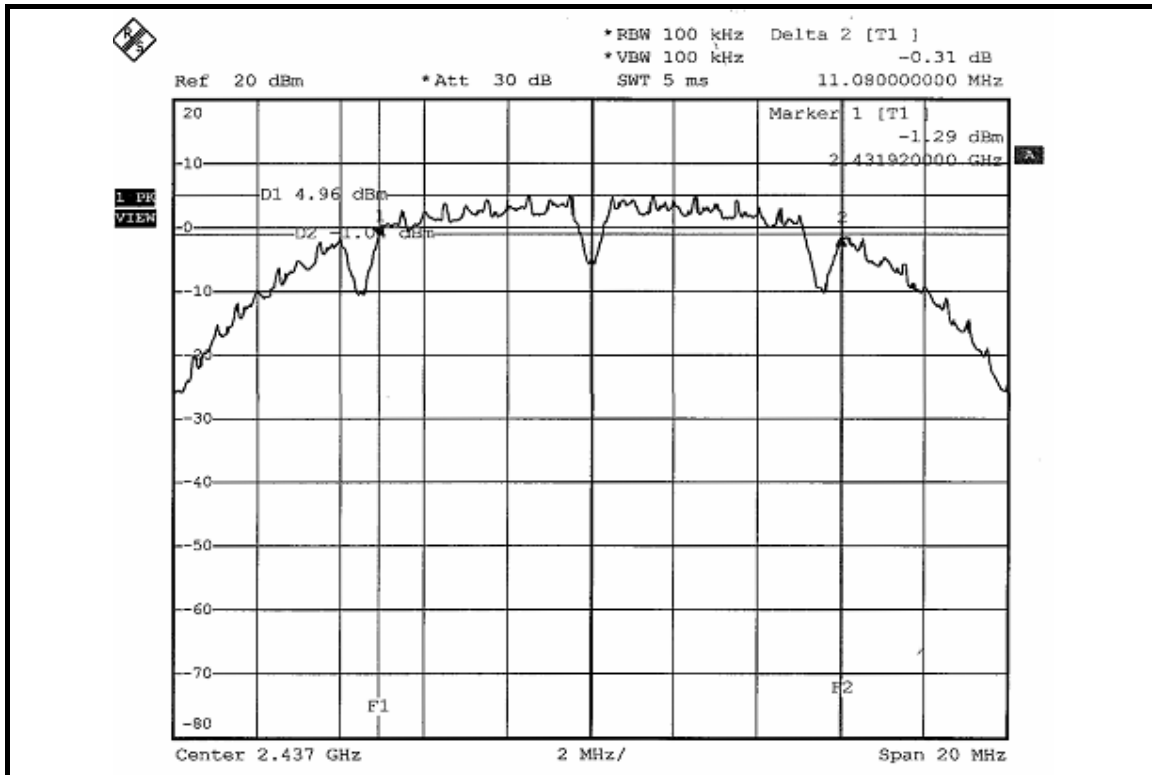

CH 11

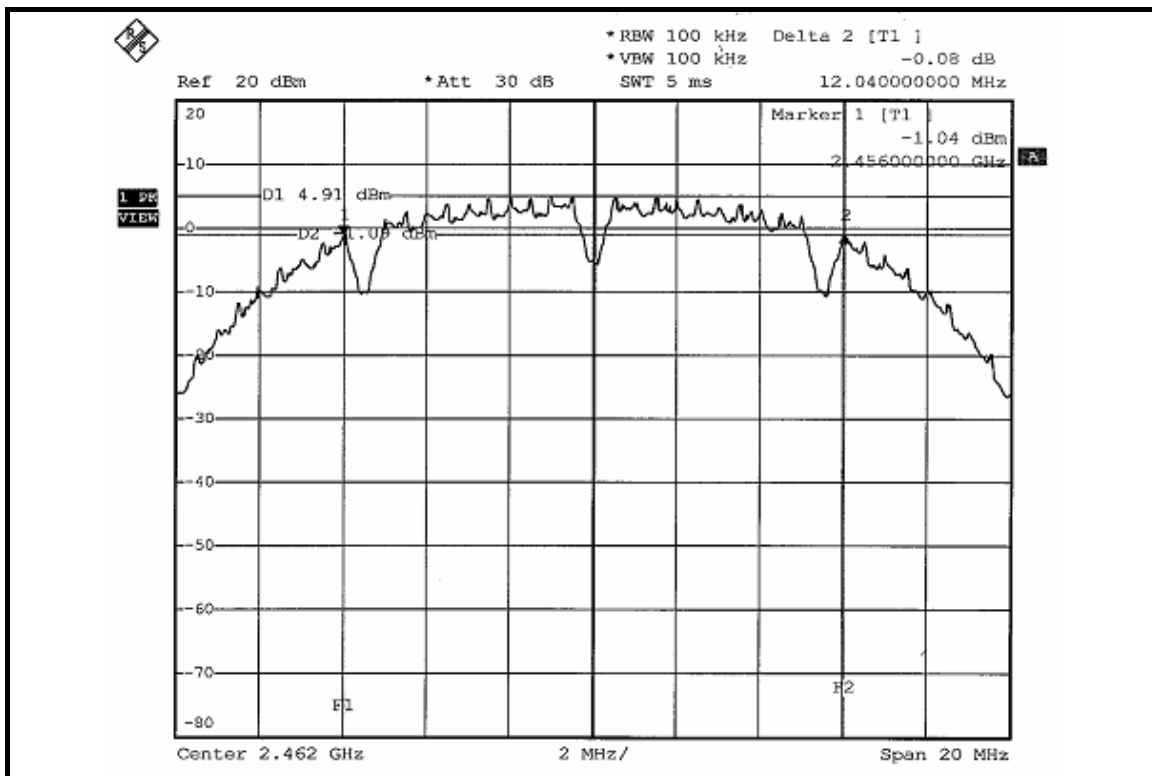

FOR CHAIN 1: CH 1

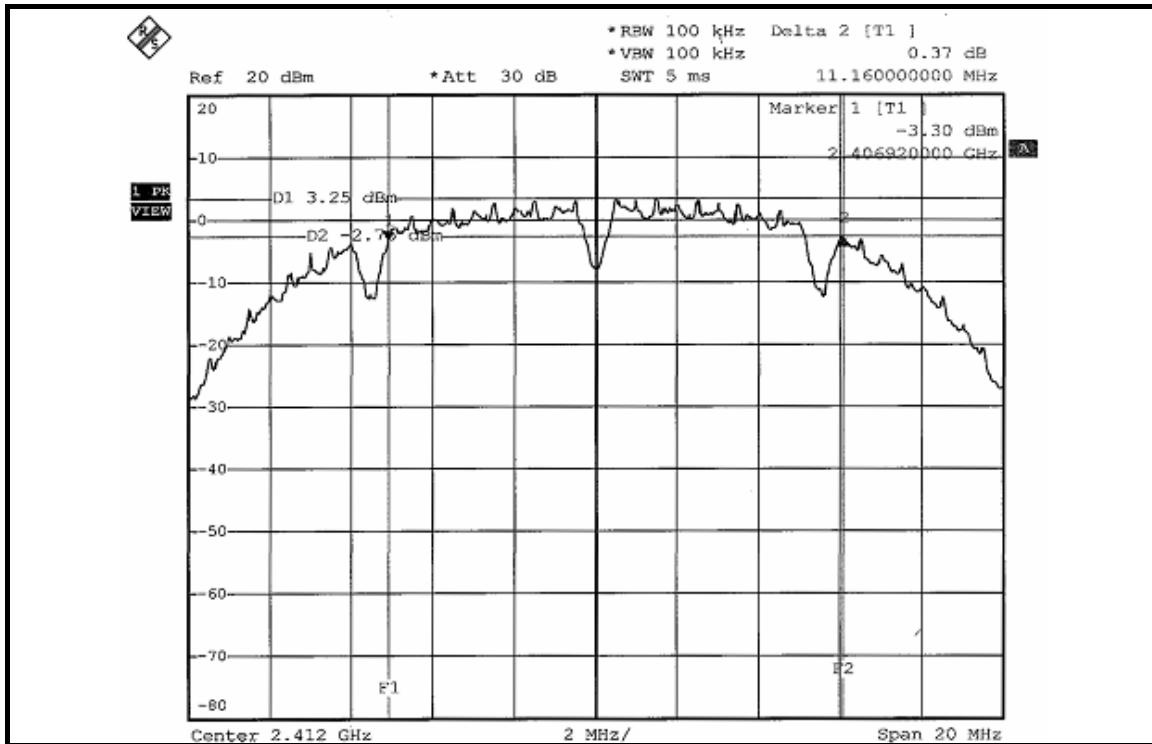

CH 6

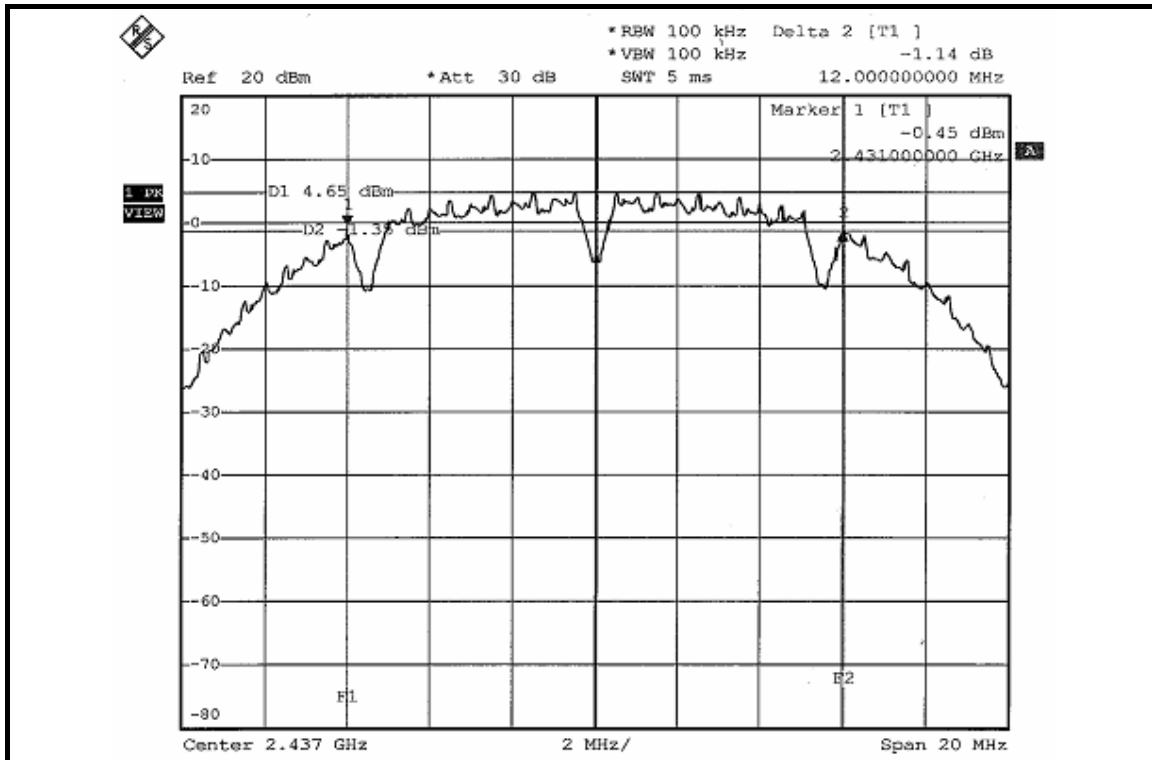

CH 11

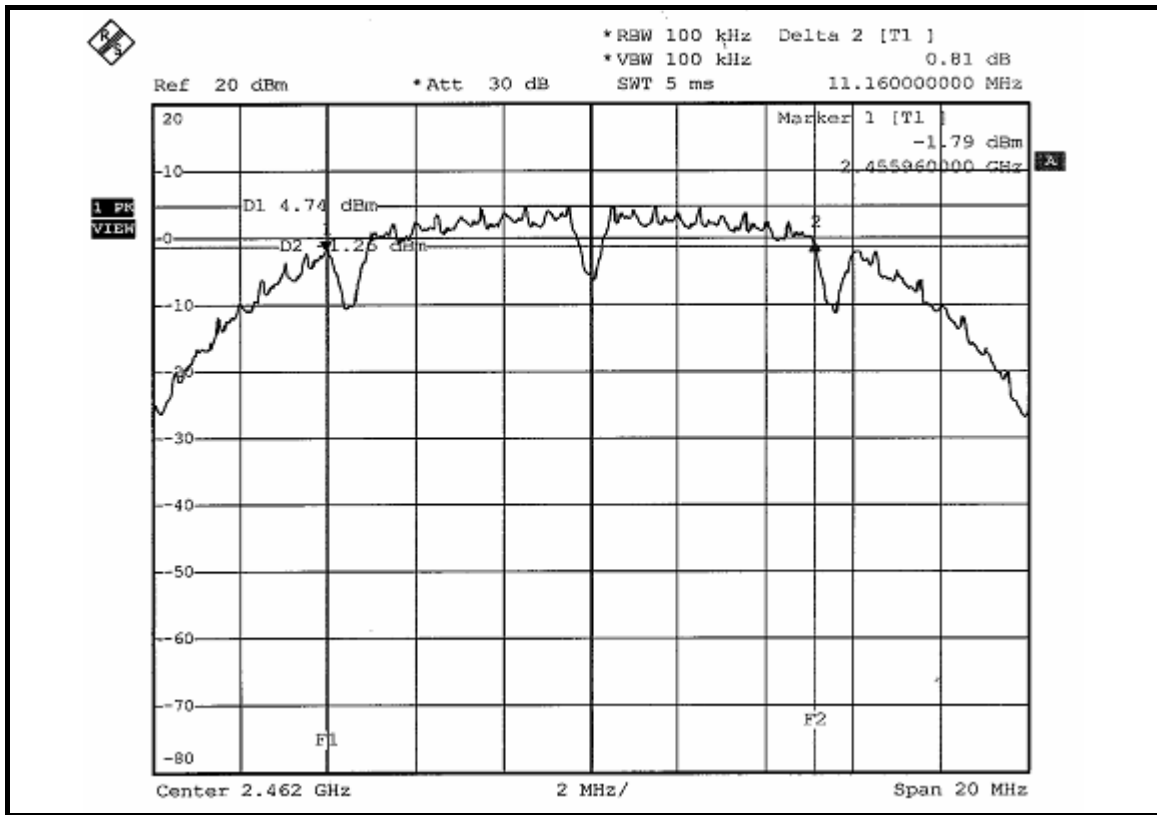

802.11g OFDM MODULATION:

MODULATION TYPE	BPSK	TRANSFER RATE	6Mbps
INPUT POWER (SYSTEM)	120Vac, 60 Hz	ENVIRONMENTAL CONDITIONS	25deg.C, 63%RH, 991hPa
TESTED BY	Long Chen		

CHANNEL	CHANNEL FREQUENCY (MHz)	6dB BANDWIDTH (MHz)		MINIMUM LIMIT (MHz)	PASS / FAIL
		CHAIN 0	CHAIN 1		
1	2412	16.36	16.32	0.5	PASS
6	2437	16.36	16.40	0.5	PASS
11	2462	16.36	16.36	0.5	PASS

FOR CHAIN 0: CH 1

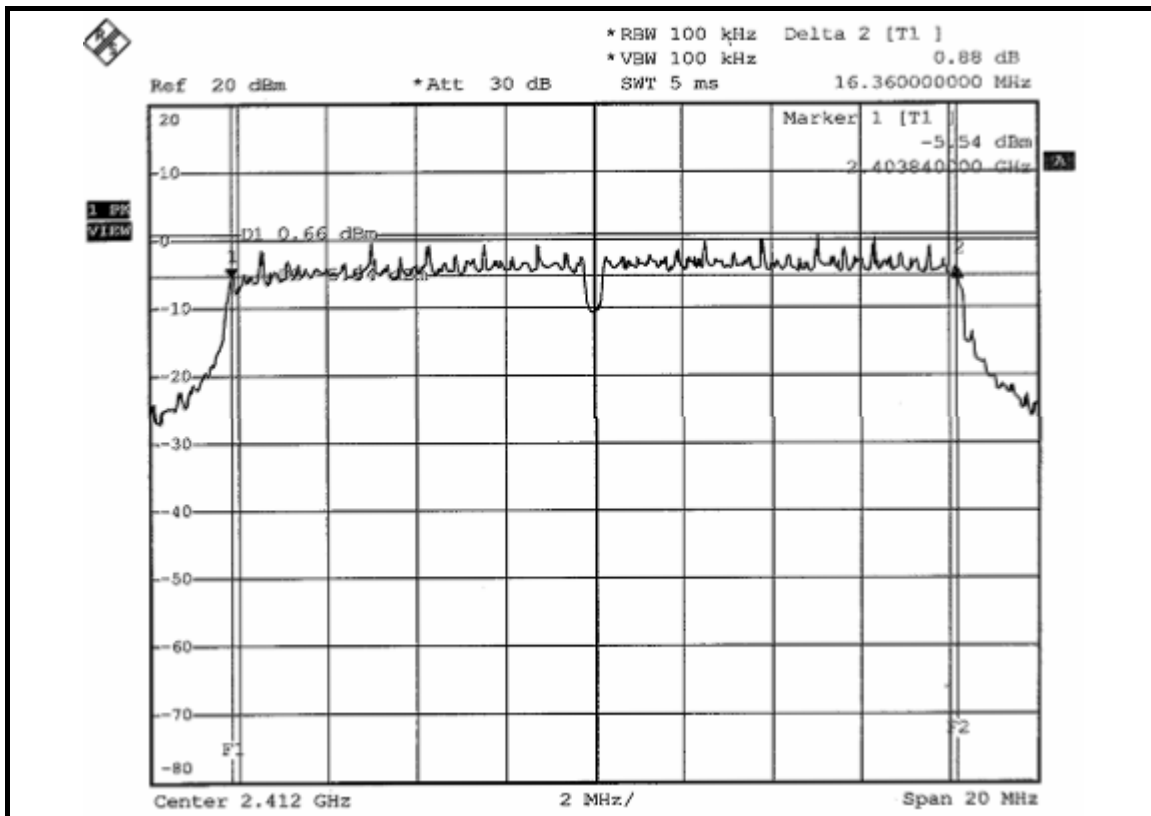

CH 6

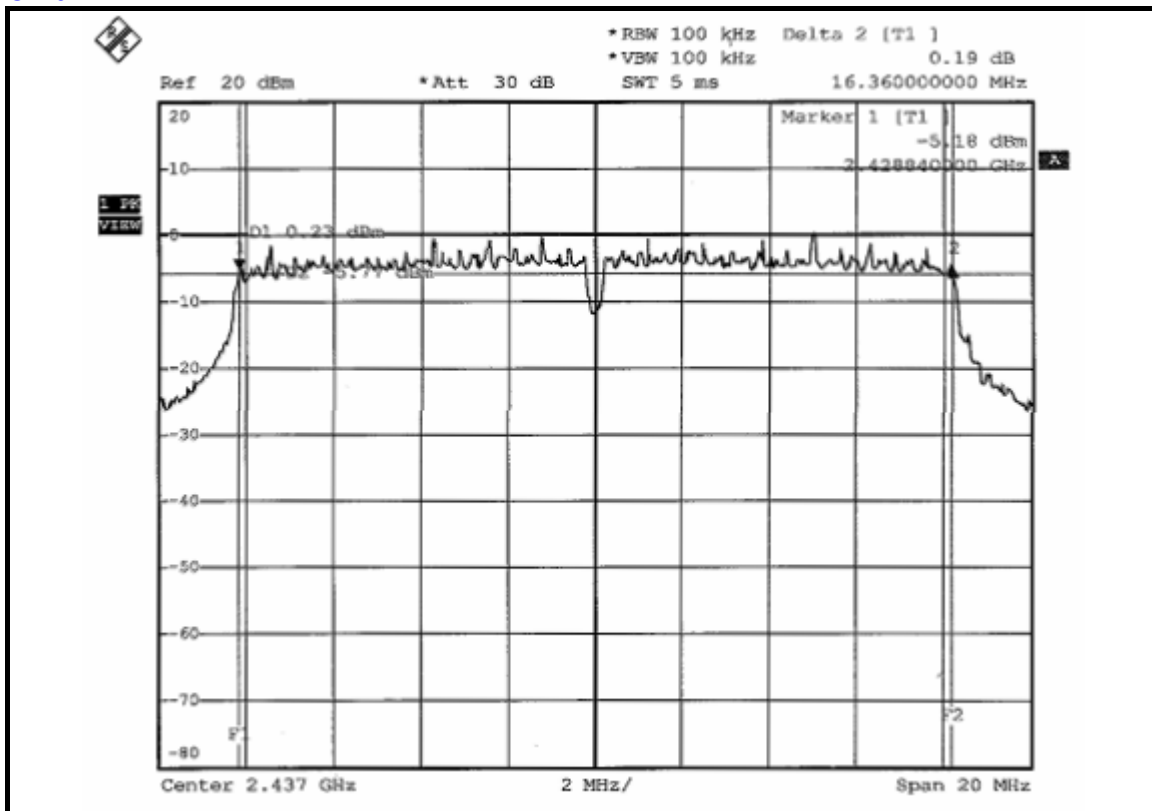

CH 11

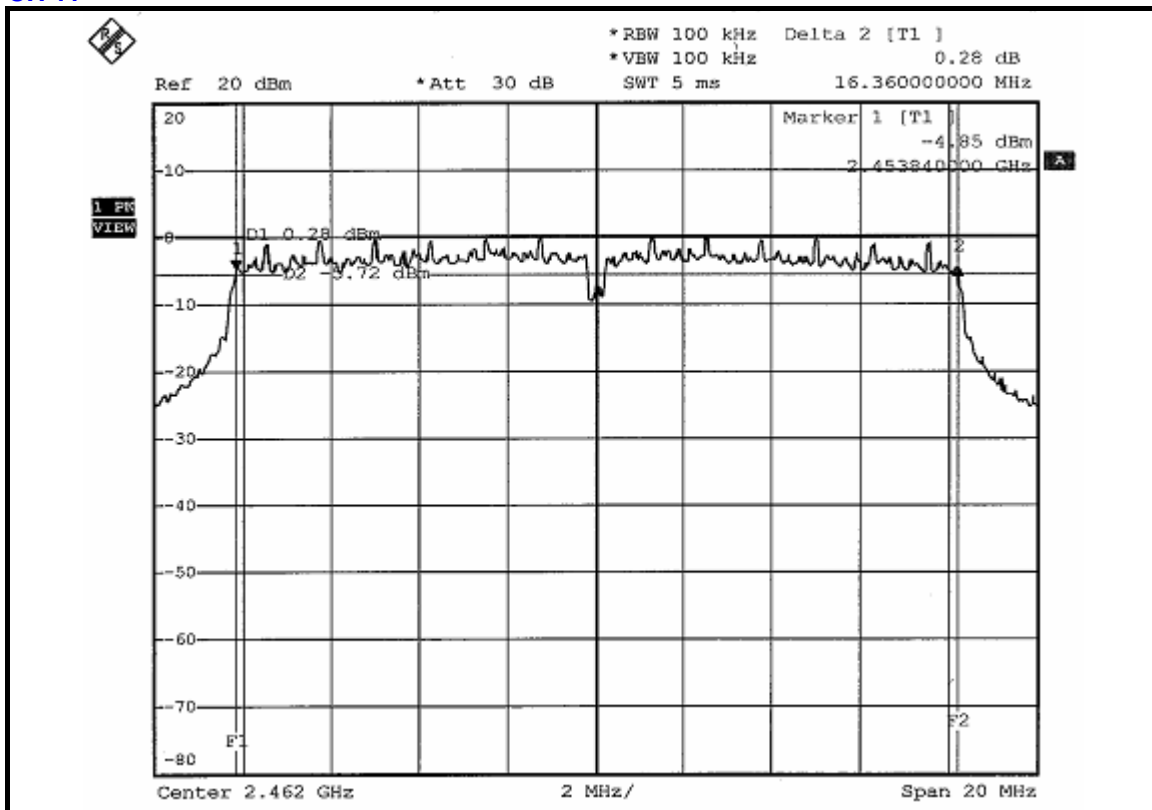

FOR CHAIN 1: CH 1

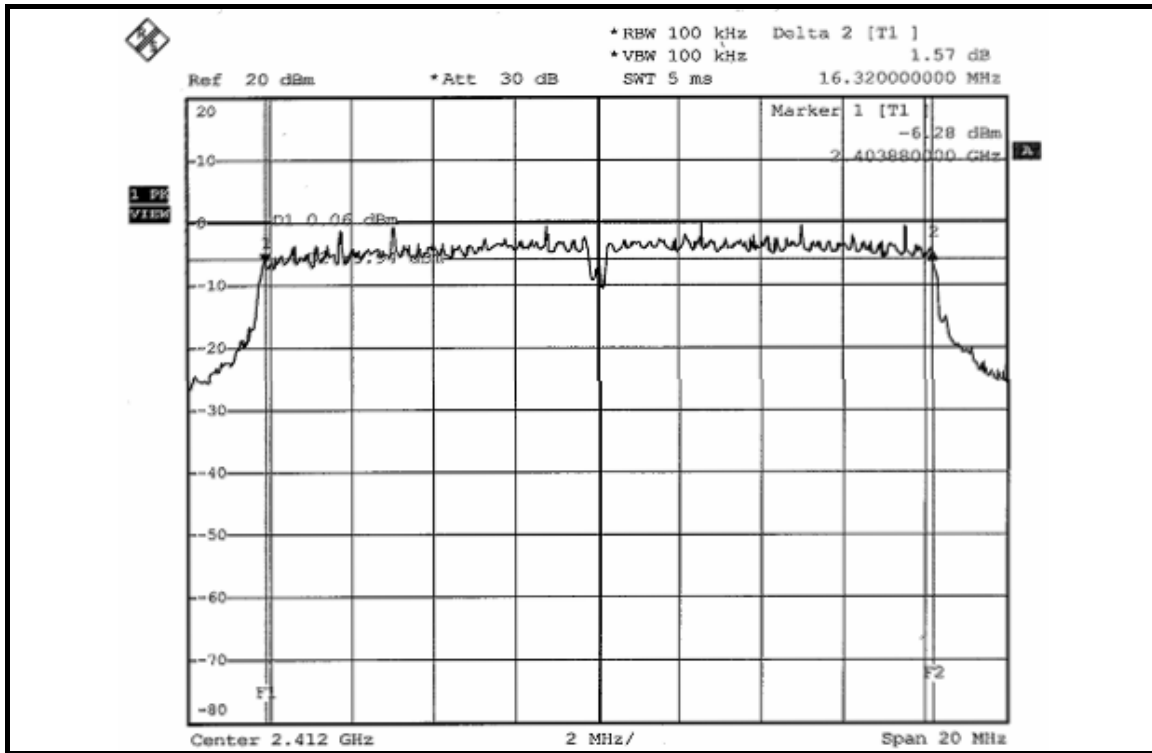

CH 6

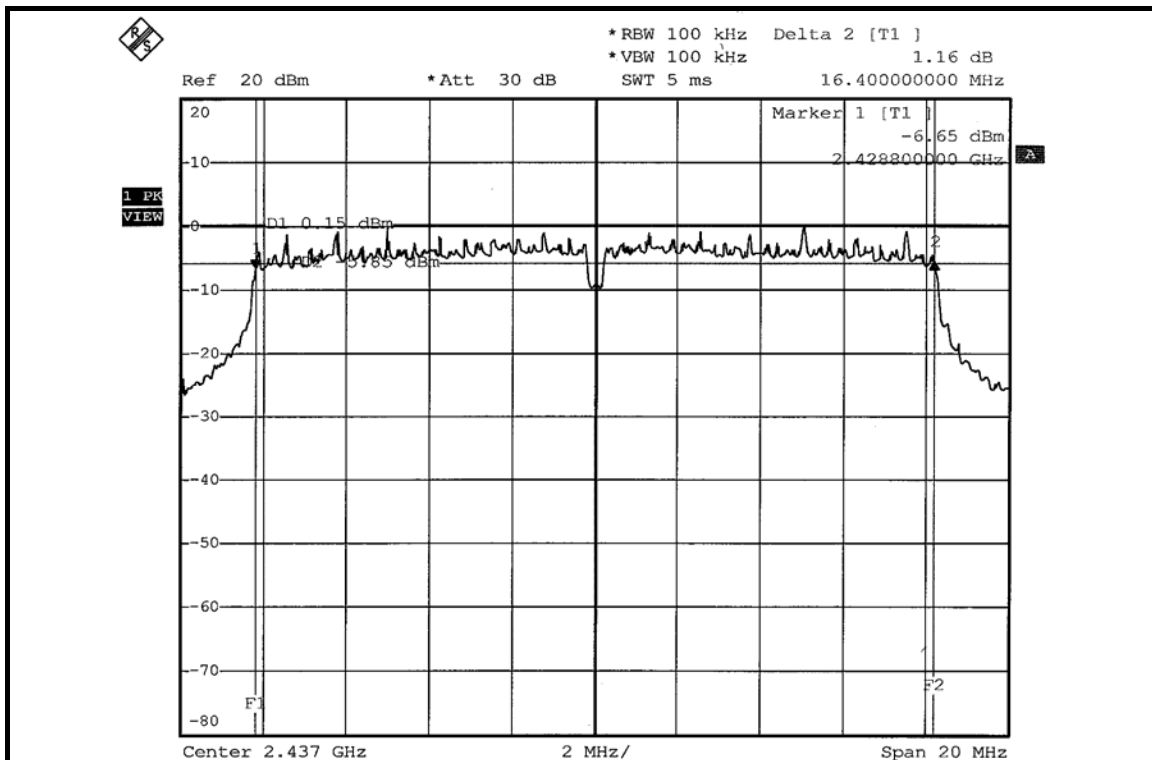



DRAFT 802.11n (20MHz) OFDM MODULATION: DUAL TX:

MODULATION TYPE	BPSK	TRANSFER RATE	7.2Mbps
INPUT POWER (SYSTEM)	120Vac, 60 Hz	ENVIRONMENTAL CONDITIONS	25deg.C, 63%RH, 991hPa
TESTED BY	Long Chen		

CHANNEL	CHANNEL FREQUENCY (MHz)	6dB BANDWIDTH (MHz)		MINIMUM LIMIT (MHz)	PASS / FAIL
		CHAIN 0	CHAIN 1		
1	2412	17.60	17.60	0.5	PASS
6	2437	17.60	17.56	0.5	PASS
11	2462	17.60	17.60	0.5	PASS

FOR CHAIN 0: CH 1

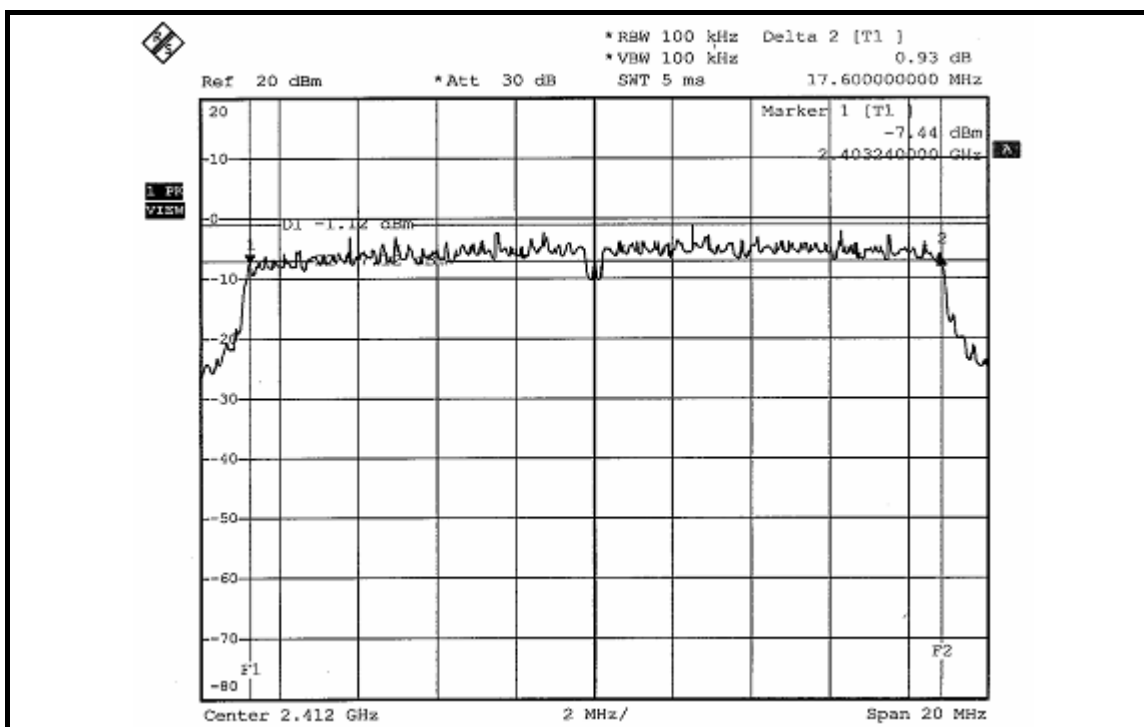

CH 6

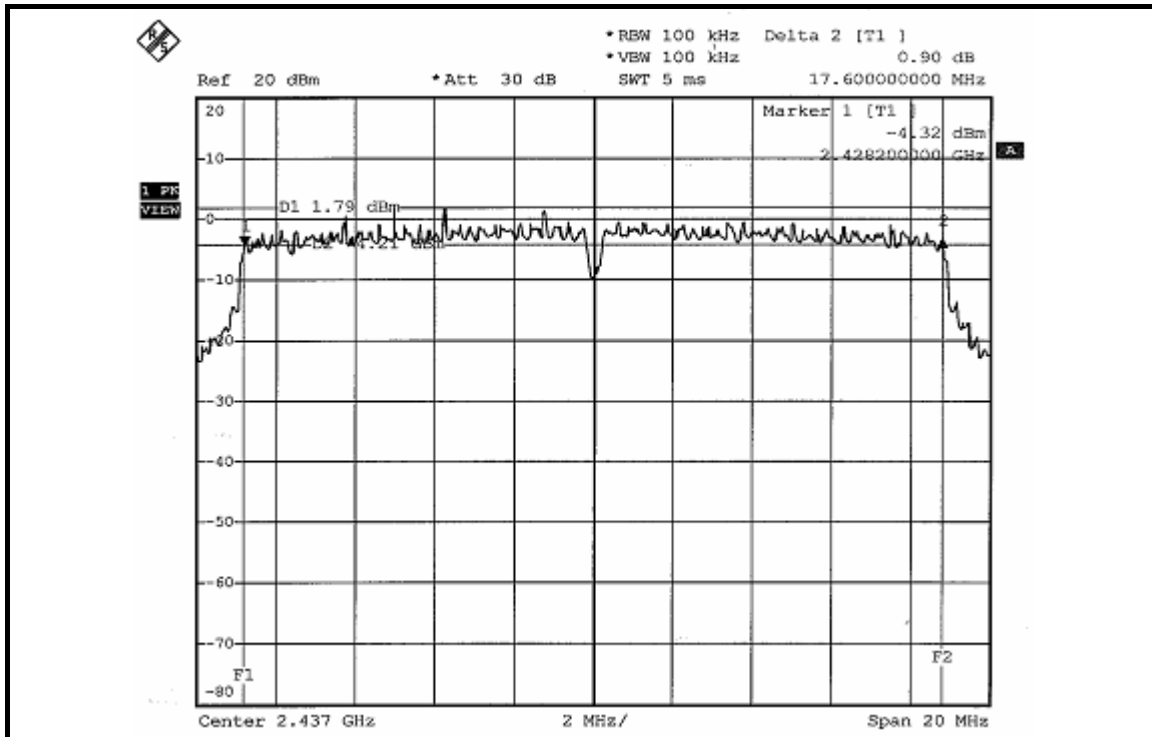

CH 11

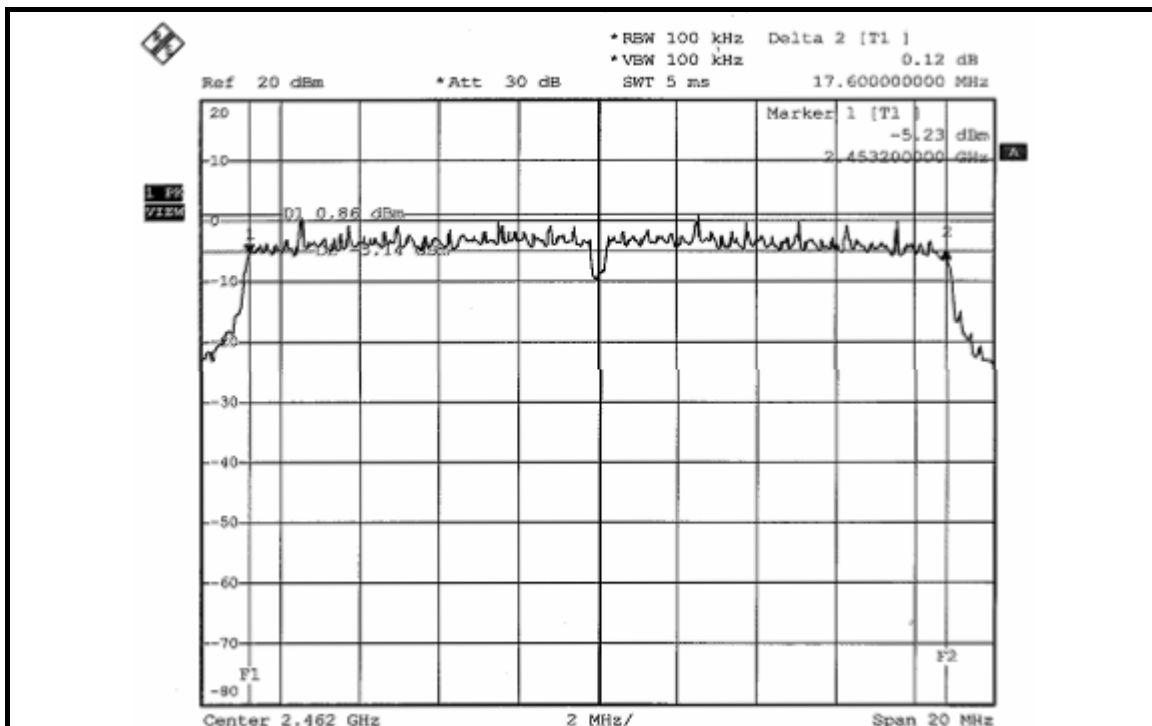

FOR CHAIN 1: CH 1

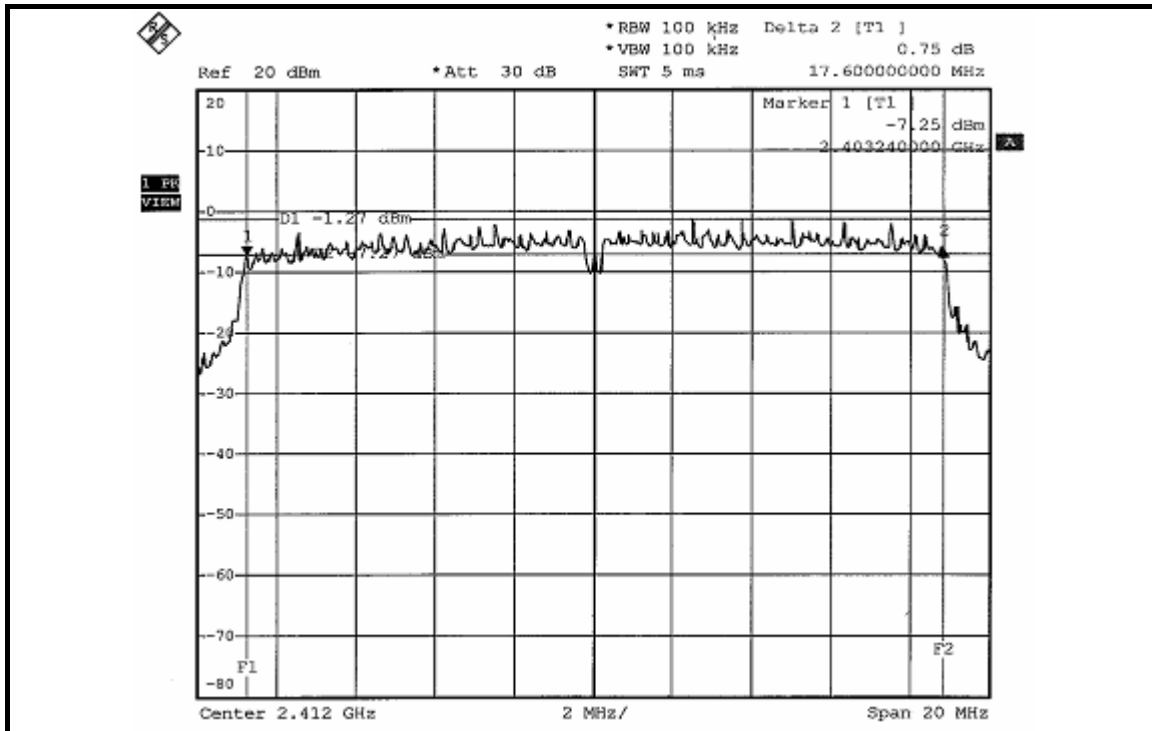

CH 6

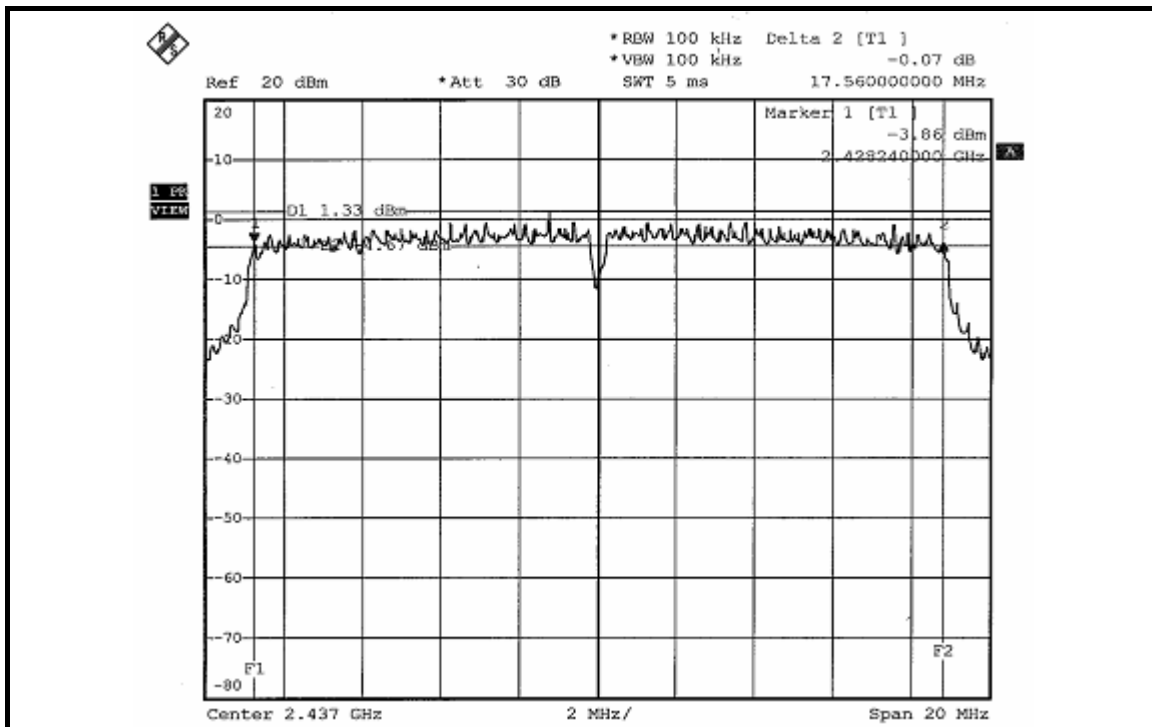

CH 11

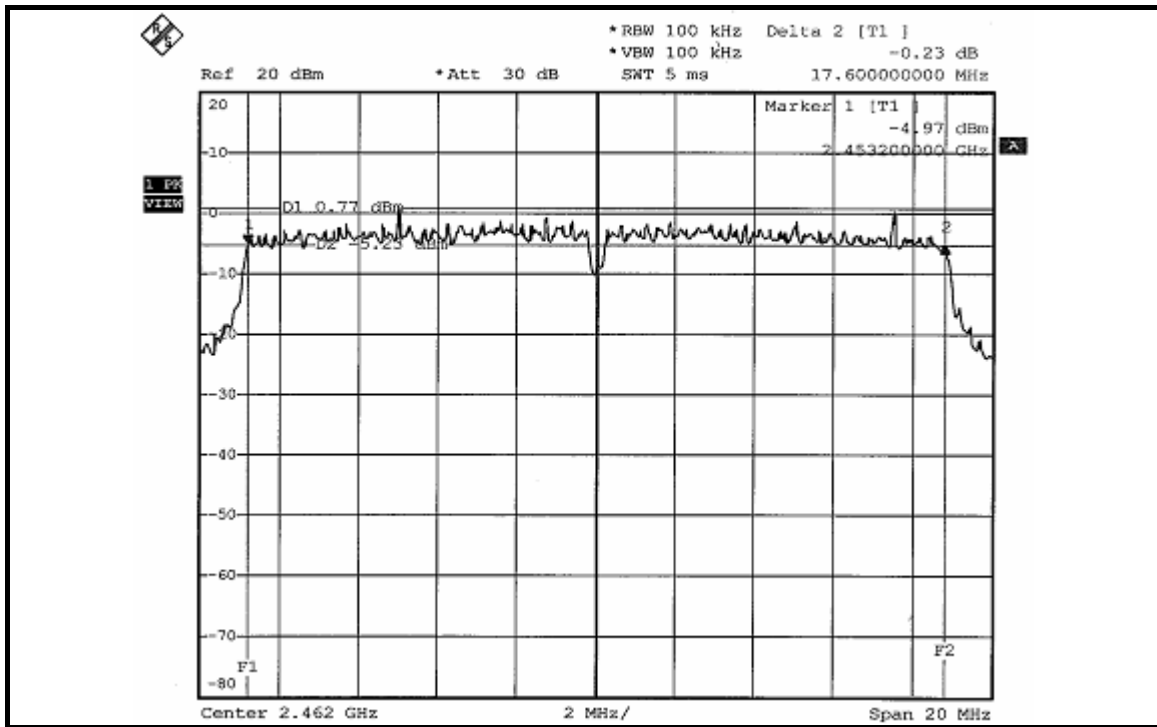

DRAFT 802.11n (40MHz) OFDM MODULATION: DUAL TX:

MODULATION TYPE	BPSK	TRANSFER RATE	15Mbps
INPUT POWER (SYSTEM)	120Vac, 60 Hz	ENVIRONMENTAL CONDITIONS	25deg.C, 63%RH, 991hPa
TESTED BY	Long Chen		

CHANNEL	CHANNEL FREQUENCY (MHz)	6dB BANDWIDTH (MHz)		MINIMUM LIMIT (MHz)	PASS / FAIL
		CHAIN 0	CHAIN 1		
1	2422	36.08	36.16	0.5	PASS
4	2437	36.40	36.40	0.5	PASS
7	2452	36.40	36.40	0.5	PASS

FOR CHAIN 0: CH 1

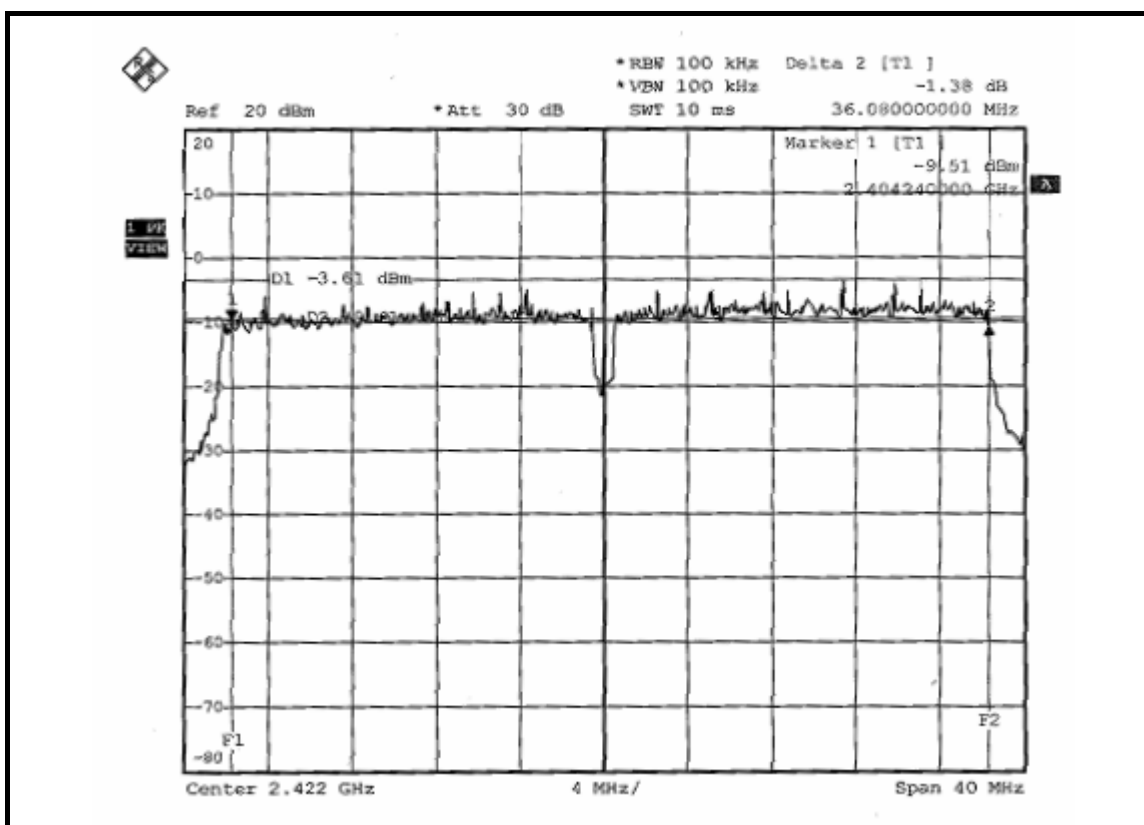

CH 4

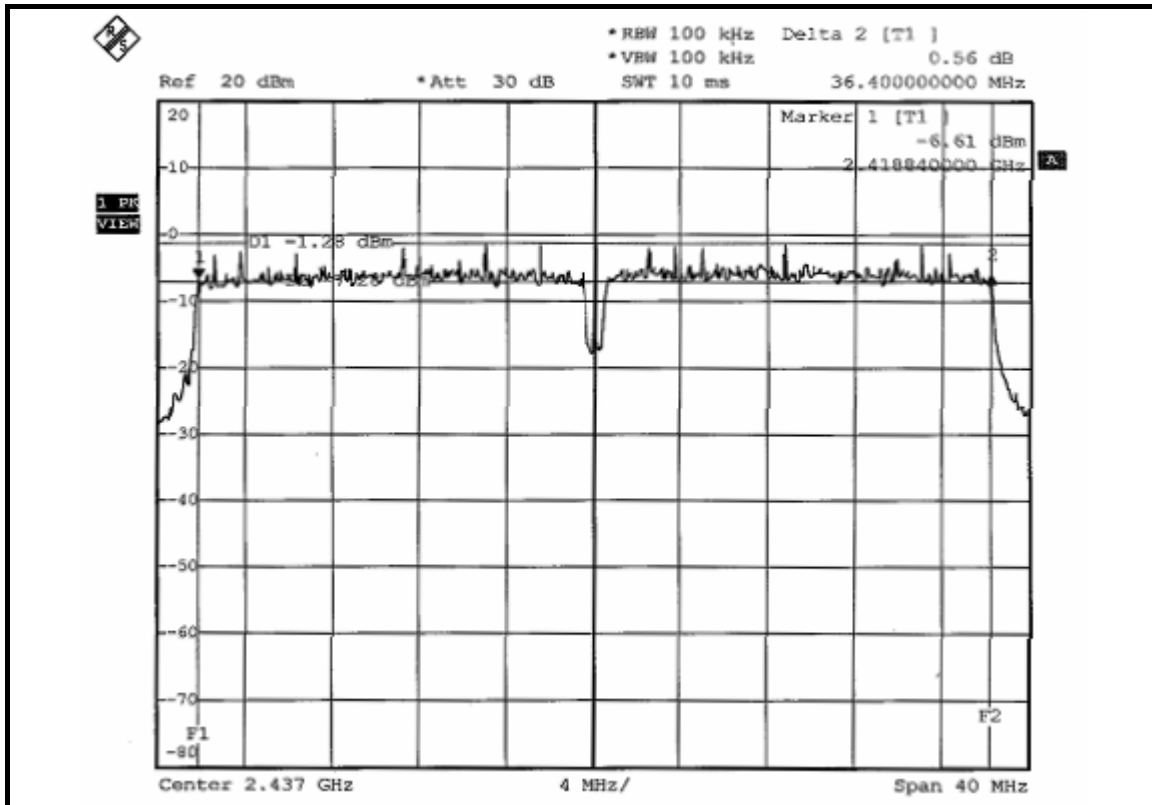

CH 7

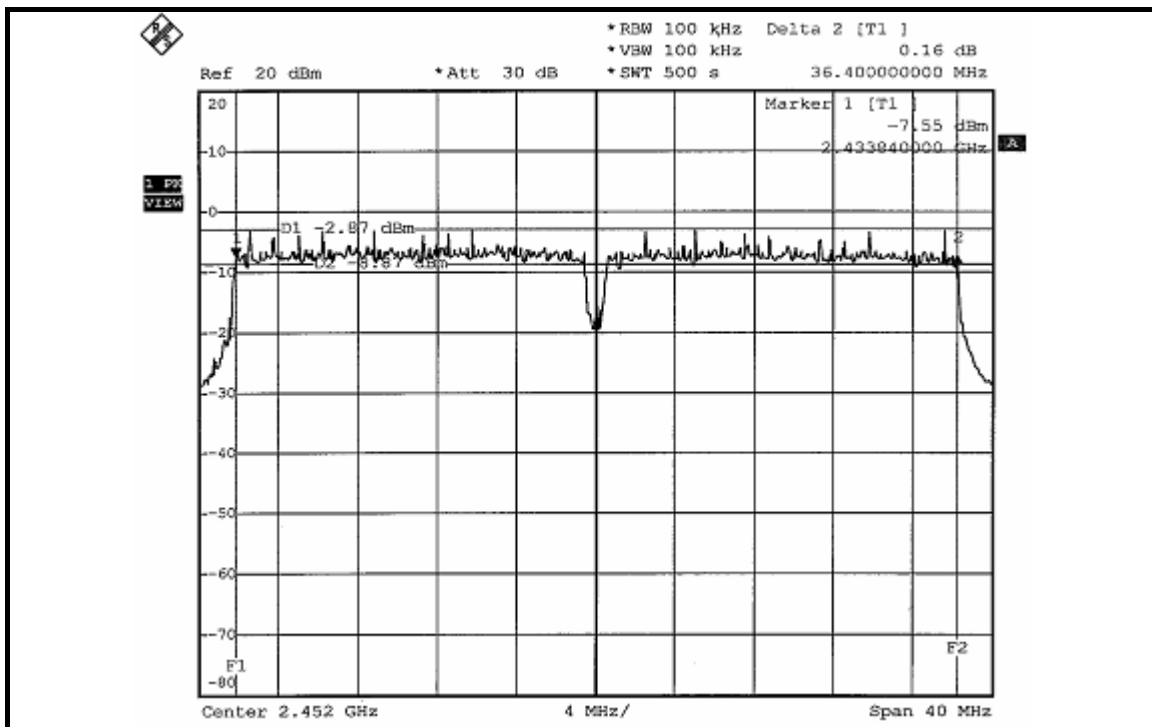

FOR CHAIN 1: CH 1

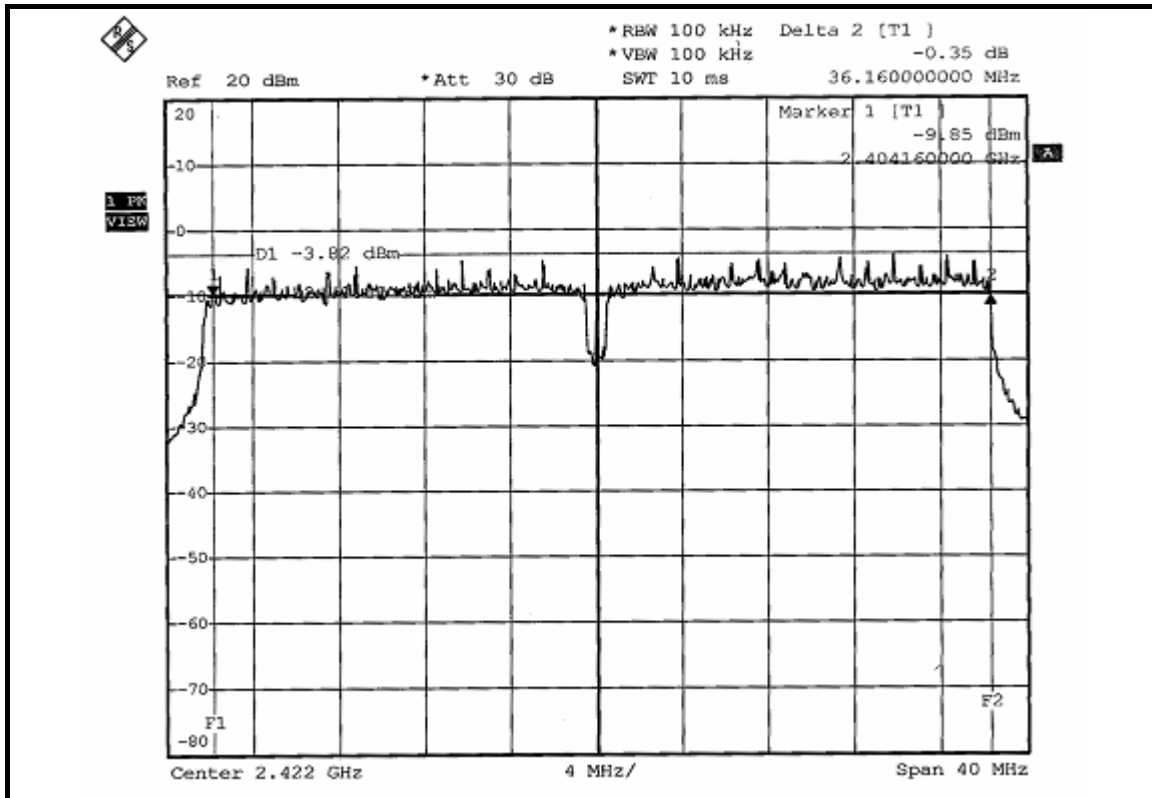

CH 4

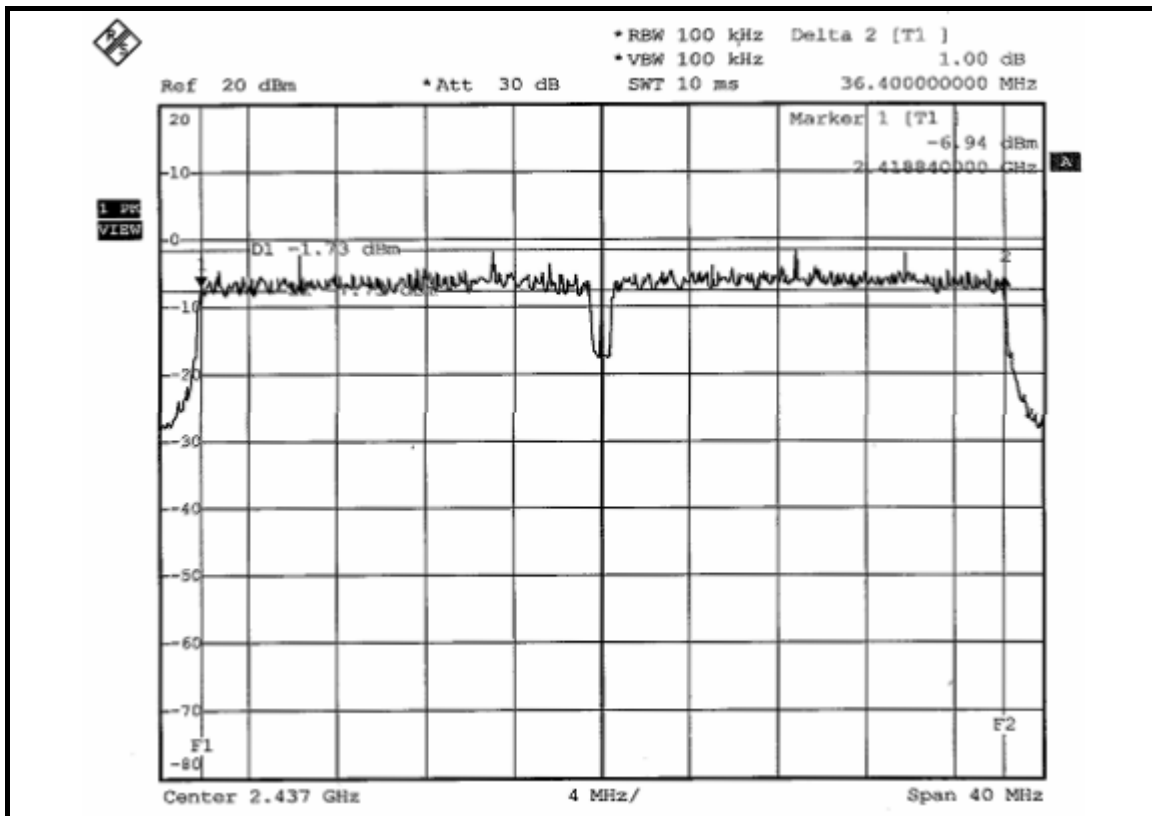

CH 7

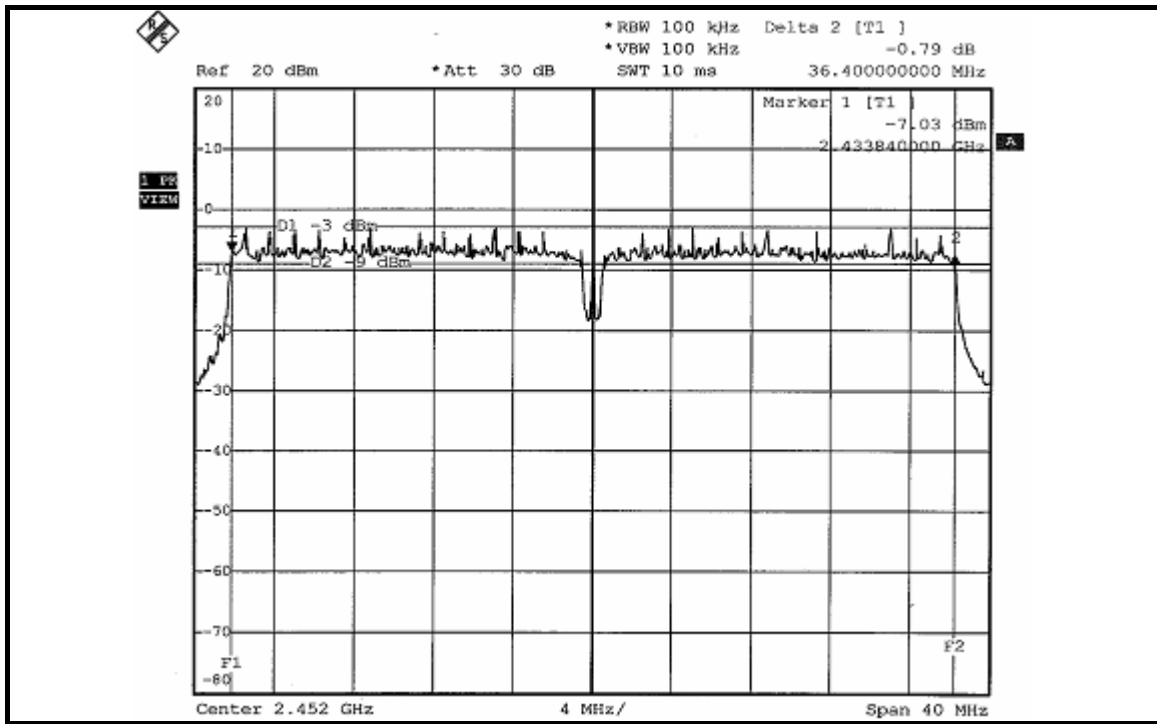

4.4 MAXIMUM PEAK OUTPUT POWER

4.4.1 LIMITS OF MAXIMUM PEAK OUTPUT POWER MEASUREMENT

The Maximum Peak Output Power Measurement is 30dBm.

4.4.2 INSTRUMENTS

DESCRIPTION & MANUFACTURER	MODEL NO.	SERIAL NO.	CALIBRATED UNTIL
R&S SPECTRUM ANALYZER	FSP40	100040	Jun. 07, 2007
Anritsu Synthesized Signal Generator	68247B	984703	May 08, 2007
DIGITAL RT OSCILLOSCOPE	TDS1012	C037299	Nov. 27, 2007
NARDA DETECTOR	4503A	FSCM99899	NA

NOTE: The calibration interval of the above test instruments is 12 months and the calibrations are traceable to NML/ROC and NIST/USA.

4.4.3 TEST PROCEDURES

1. A detector was used on the output port of the EUT. An oscilloscope was used to read the response of the detector.
2. Replaced the EUT by the signal generator. The center frequency of the S.G was adjusted to the center frequency of the measured channel.
3. Adjusted the power to have the same reading on oscilloscope. Record the power level.

4.4.4 DEVIATION FROM TEST STANDARD

No deviation

4.4.5 TEST SETUP



4.4.6 EUT OPERATING CONDITIONS

Same as Item 4.3.6.

4.4.7 TEST RESULTS

802.11b DSSS MODULATION:

MODULATION TYPE	DBPSK	TRANSFER RATE	1Mbps
INPUT POWER (SYSTEM)	120Vac, 60 Hz	ENVIRONMENTAL CONDITIONS	25deg.C, 63%RH, 991hPa
TESTED BY	Long Chen		

CHANNEL	CHANNEL FREQUENCY (MHz)	PEAK POWER OUTPUT (mW)		PEAK POWER OUTPUT (dBm)		TOTAL PEAK POWER (mW)	TOTAL PEAK POWER (dBm)	PEAK POWER LIMIT (dBm)	PASS / FAIL
		CHAIN 0	CHAIN 1	CHAIN 0	CHAIN 1				
1	2412	40.644	39.902	16.09	16.01	80.547	19.06	30	PASS
6	2437	64.863	63.241	18.12	18.01	128.105	21.08	30	PASS
11	2462	65.163	63.973	18.14	18.06	129.136	21.11	30	PASS

802.11g OFDM MODULATION:

MODULATION TYPE	BPSK	TRANSFER RATE	6Mbps
INPUT POWER (SYSTEM)	120Vac, 60 Hz	ENVIRONMENTAL CONDITIONS	25deg.C, 63%RH, 991hPa
TESTED BY	Long Chen		

CHANNEL	CHANNEL FREQUENCY (MHz)	PEAK POWER OUTPUT (mW)		PEAK POWER OUTPUT (dBm)		TOTAL PEAK POWER (mW)	TOTAL PEAK POWER (dBm)	PEAK POWER LIMIT (dBm)	PASS / FAIL
		CHAIN 0	CHAIN 1	CHAIN 0	CHAIN 1				
1	2412	40.738	39.994	16.10	16.02	80.733	19.07	30	PASS
6	2437	40.926	40.087	16.12	16.03	81.013	19.09	30	PASS
11	2462	40.926	40.365	16.12	16.06	81.291	19.10	30	PASS



DRAFT 802.11n (20MHz) OFDM MODULATION: DUAL TX:

MODULATION TYPE	BPSK	TRANSFER RATE	7.2Mbps
INPUT POWER (SYSTEM)	120Vac, 60 Hz	ENVIRONMENTAL CONDITIONS	25deg.C, 63%RH, 991hPa
TESTED BY	Long Chen		

CHANNEL	CHANNEL FREQUENCY (MHz)	PEAK POWER OUTPUT (mW)		PEAK POWER OUTPUT (dBm)		TOTAL PEAK POWER (mW)	TOTAL PEAK POWER (dBm)	PEAK POWER LIMIT (dBm)	PASS / FAIL
		CHAIN 0	CHAIN 1	CHAIN 0	CHAIN 1				
1	2412	29.242	28.973	14.66	14.62	58.215	17.65	30	PASS
6	2437	45.814	45.394	16.61	16.57	91.208	19.60	30	PASS
11	2462	46.238	44.875	16.65	16.52	91.113	19.60	30	PASS

DRAFT 802.11n (40MHz) OFDM MODULATION: DUAL TX:

MODULATION TYPE	BPSK	TRANSFER RATE	15Mbps
INPUT POWER (SYSTEM)	120Vac, 60 Hz	ENVIRONMENTAL CONDITIONS	25deg.C, 63%RH, 991hPa
TESTED BY	Long Chen		

CHANNEL	CHANNEL FREQUENCY (MHz)	PEAK POWER OUTPUT (mW)		PEAK POWER OUTPUT (dBm)		TOTAL PEAK POWER (mW)	TOTAL PEAK POWER (dBm)	PEAK POWER LIMIT (dBm)	PASS / FAIL
		CHAIN 0	CHAIN 1	CHAIN 0	CHAIN 1				
1	2422	28.840	28.379	14.60	14.53	57.220	17.58	30	PASS
4	2437	46.345	45.394	16.66	16.57	91.739	19.63	30	PASS
7	2452	39.898	35.724	15.67	15.53	72.625	18.61	30	PASS



4.5 POWER SPECTRAL DENSITY MEASUREMENT

4.5.1 LIMITS OF POWER SPECTRAL DENSITY MEASUREMENT

The Maximum of Power Spectral Density Measurement is 8dBm.

4.5.2 TEST INSTRUMENTS

DESCRIPTION & MANUFACTURER	MODEL NO.	SERIAL NO.	CALIBRATED UNTIL
R&S SPECTRUM ANALYZER	FSP40	100040	Jun. 07, 2007

NOTE: The calibration interval of the above test instruments is 12 months and the calibrations are traceable to NML/ROC and NIST/USA.

4.5.3 TEST PROCEDURE

The transmitter output was connected to the spectrum analyzer through an attenuator, the bandwidth of the fundamental frequency was measured with the spectrum analyzer using 3kHz RBW and 30kHz VBW, set sweep time = span/3kHz. The power spectral density was measured and recorded.

The sweep time is allowed to be longer than span/3kHz for a full response of the mixer in the spectrum analyzer.

4.5.4 DEVIATION FROM TEST STANDARD

No deviation

4.5.5 TEST SETUP

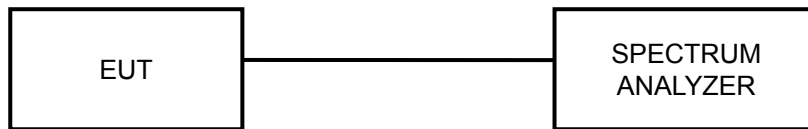

4.5.6 EUT OPERATING CONDITION

Same as Item 4.3.6.

4.5.7 TEST RESULTS

802.11b DSSS MODULATION:

MODULATION TYPE	DBPSK	TRANSFER RATE	1Mbps
INPUT POWER (SYSTEM)	120Vac, 60 Hz	ENVIRONMENTAL CONDITIONS	25deg.C, 63%RH, 991hPa
TESTED BY	Long Chen		

CHANNEL	CHANNEL FREQUENCY (MHz)	RF POWER LEVEL IN 3kHz BW (mW)		RF POWER LEVEL IN 3kHz BW (dBm)		TOTAL POWER DENSITY (mW)	TOTAL POWER DENSITY (dBm)	MAX. LIMIT (dBm)	PASS / FAIL
		CHAIN 0	CHAIN 1	CHAIN 0	CHAIN 1				
1	2412	0.039	0.072	-14.11	-14.41	0.111	-9.547	8	PASS
6	2437	0.065	0.061	-11.89	-12.14	0.126	-8.996	8	PASS
11	2462	0.064	0.062	-11.94	-12.11	0.125	-9.031	8	PASS

FOR CHAIN 0: CH 1

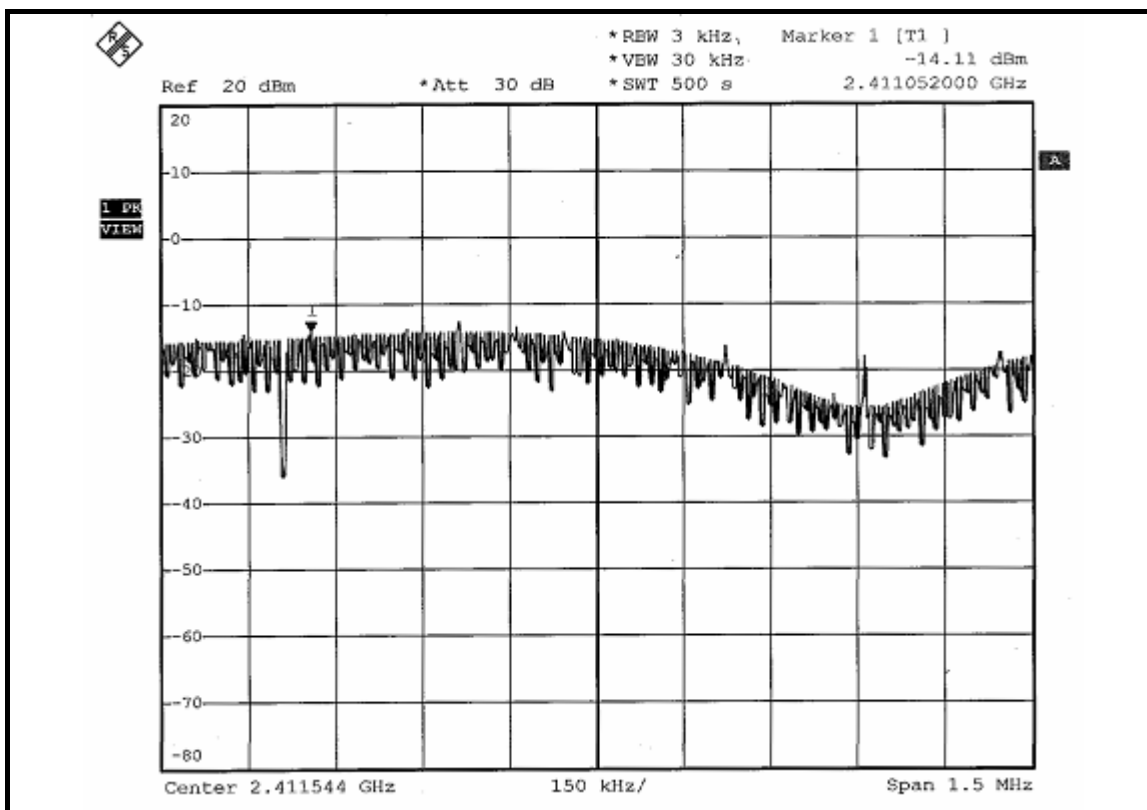

CH 6

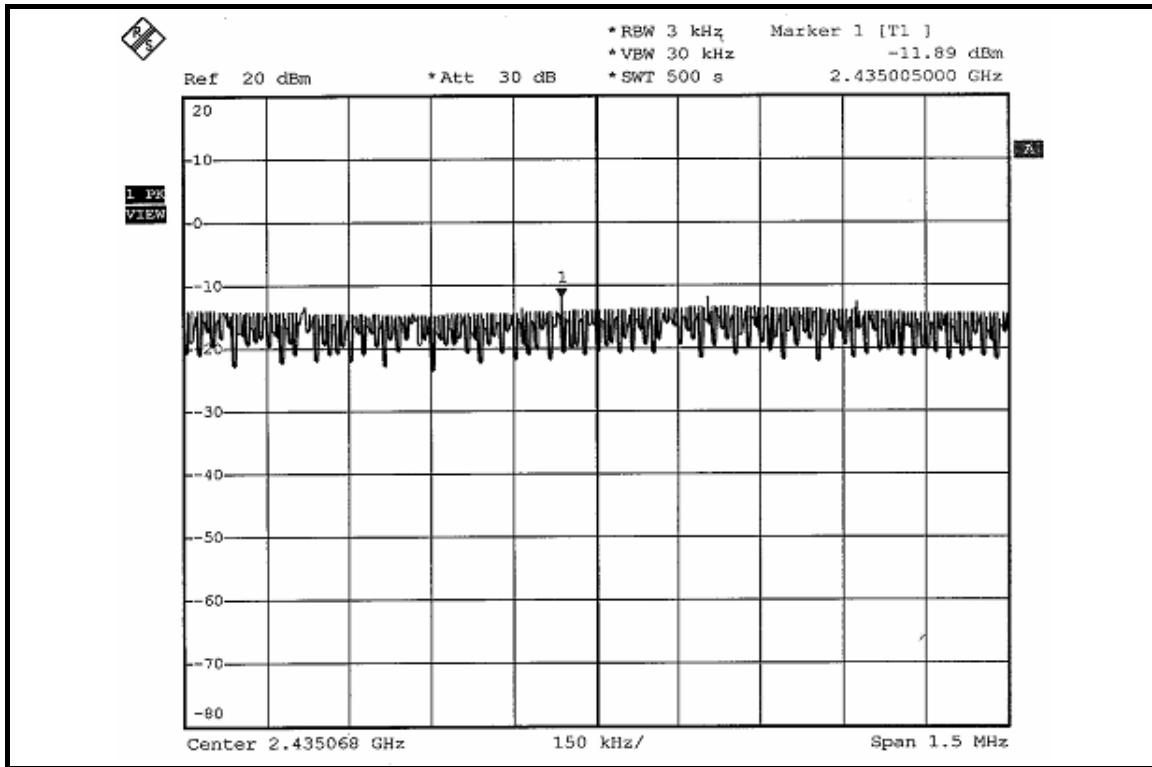

CH 11

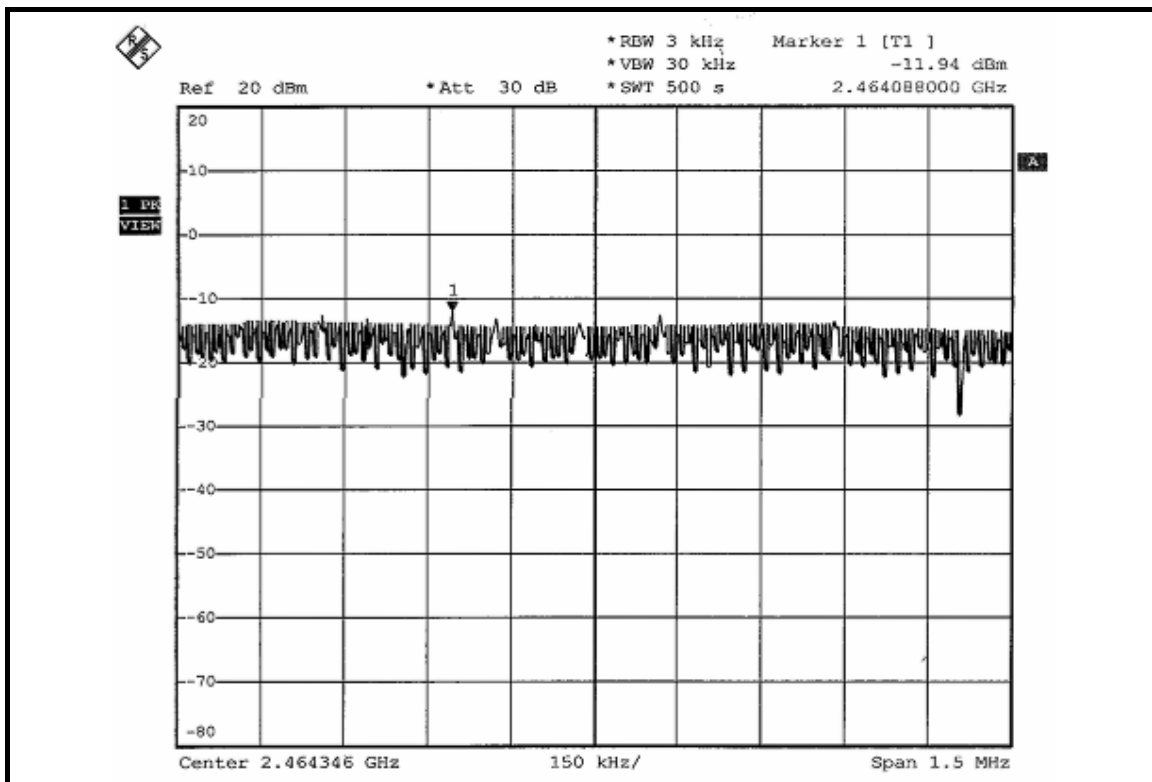

FOR CHAIN 1: CH 1

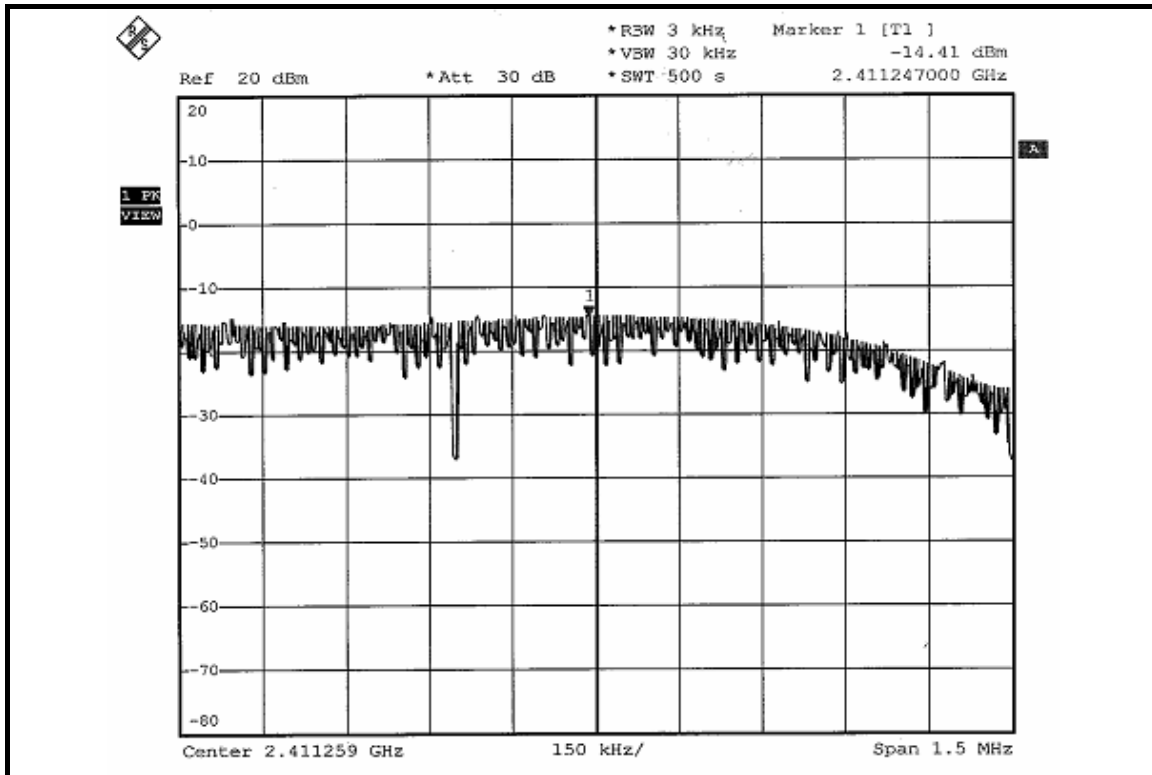

CH 6

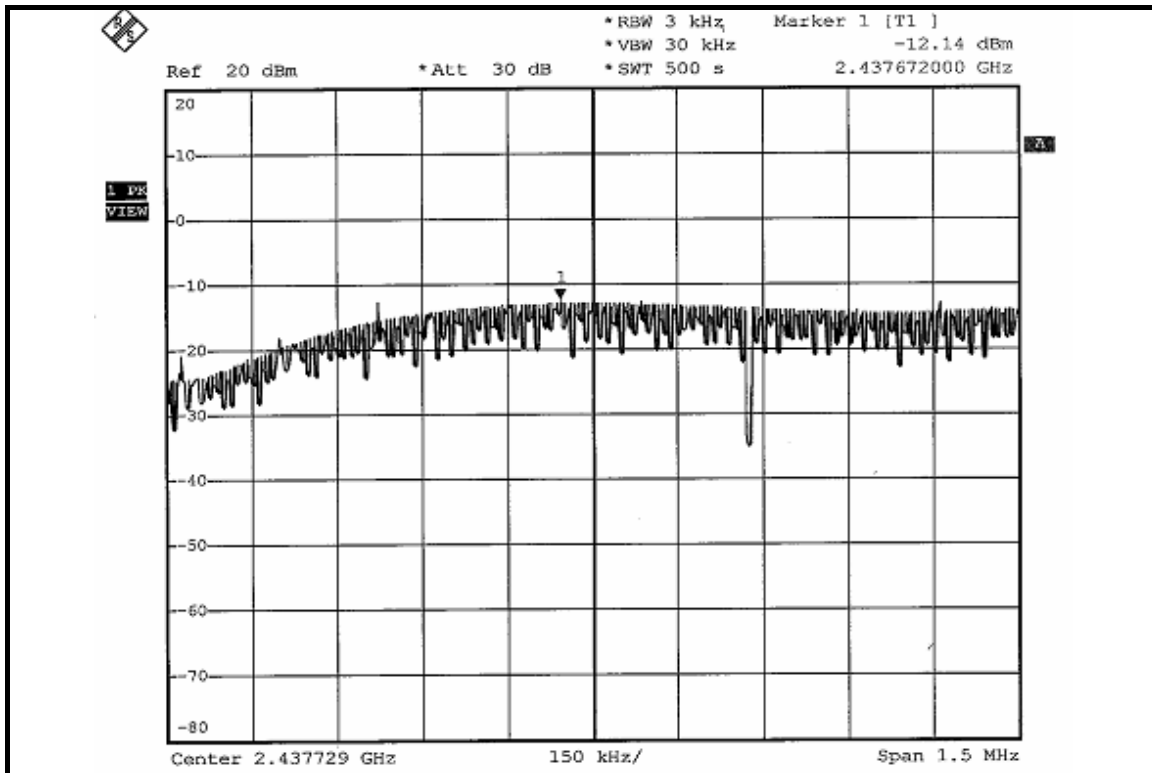

CH 11

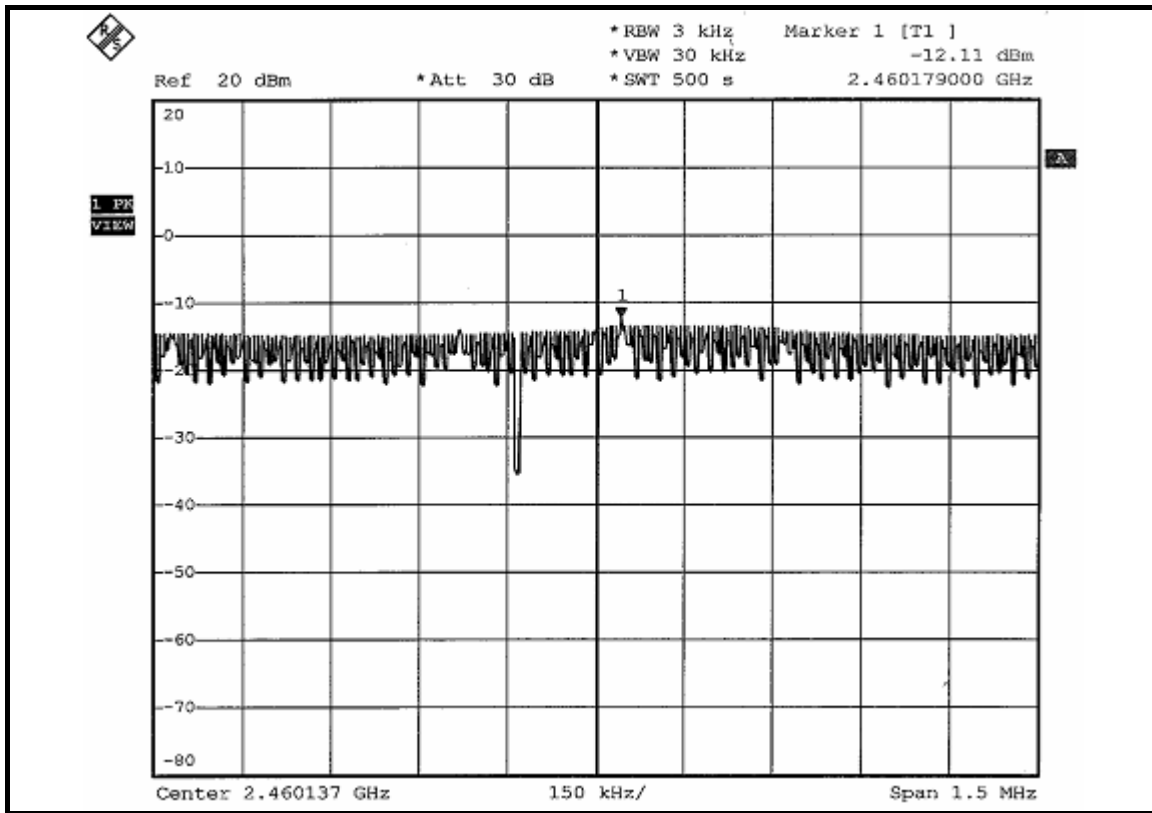

802.11g OFDM MODULATION:

MODULATION TYPE	BPSK	TRANSFER RATE	6Mbps
INPUT POWER (SYSTEM)	120Vac, 60 Hz	ENVIRONMENTAL CONDITIONS	25deg.C, 63%RH, 991hPa
TESTED BY	Long Chen		

CHANNEL	CHANNEL FREQUENCY (MHz)	RF POWER LEVEL IN 3kHz BW (mW)		RF POWER LEVEL IN 3kHz BW (dBm)		TOTAL POWER DENSITY (mW)	TOTAL POWER DENSITY (dBm)	MAX. LIMIT (dBm)	PASS / FAIL
		CHAIN 0	CHAIN 1	CHAIN 0	CHAIN 1				
1	2412	0.025	0.024	-15.95	-16.18	0.049	-13.098	8	PASS
6	2437	0.025	0.024	-16.04	-16.22	0.049	-13.098	8	PASS
11	2462	0.025	0.024	-16.06	-16.16	0.049	-13.098	8	PASS

FOR CHAIN 0: CH 1

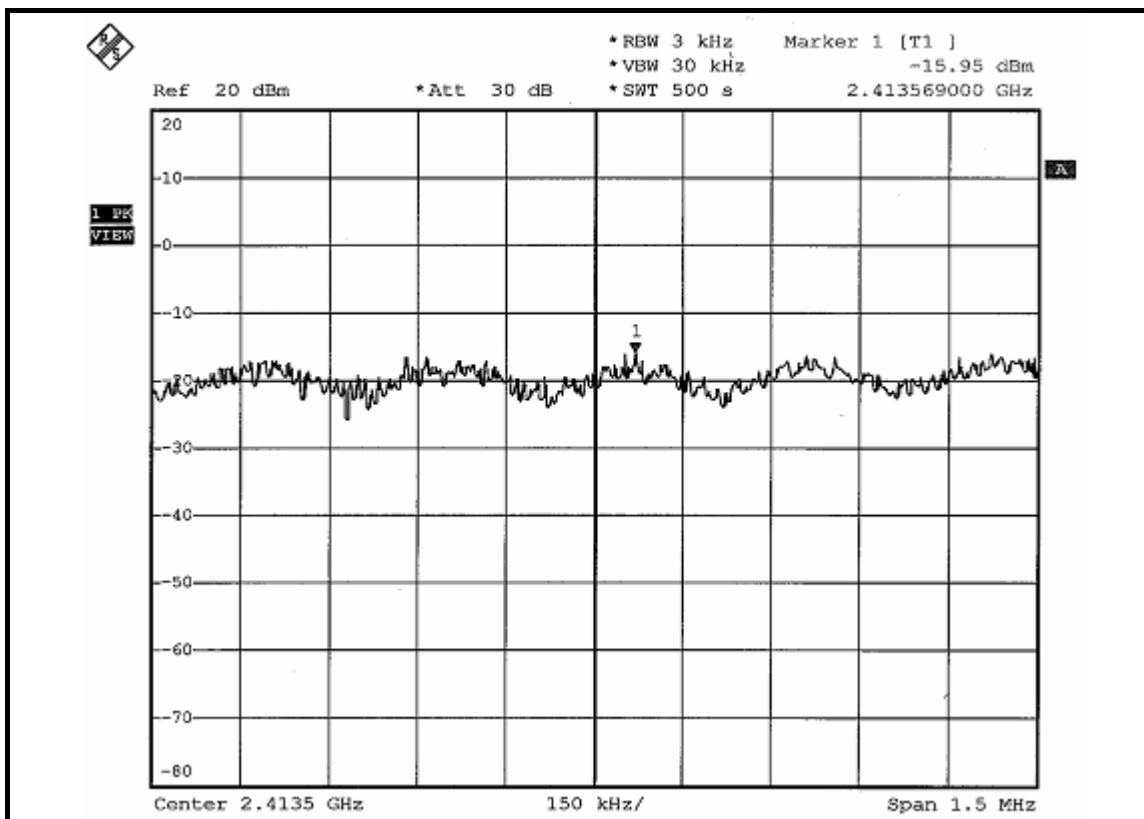

CH 6

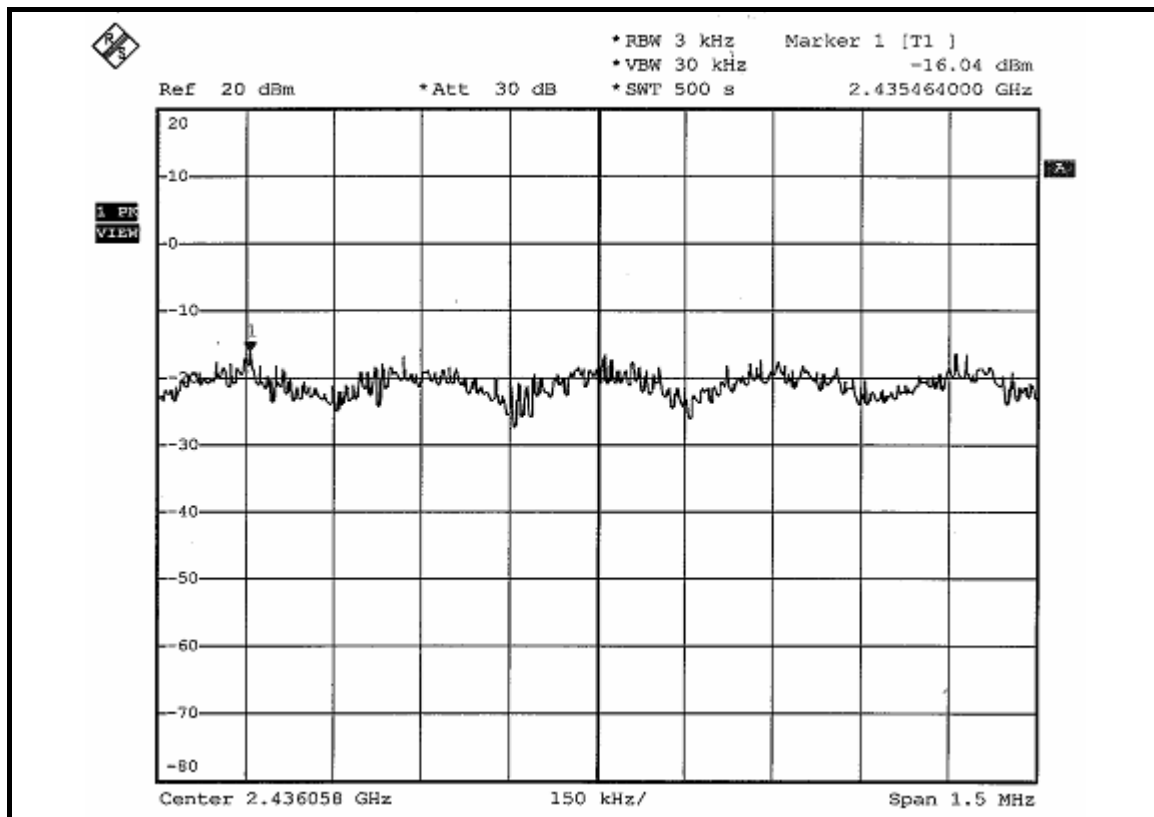

CH 11

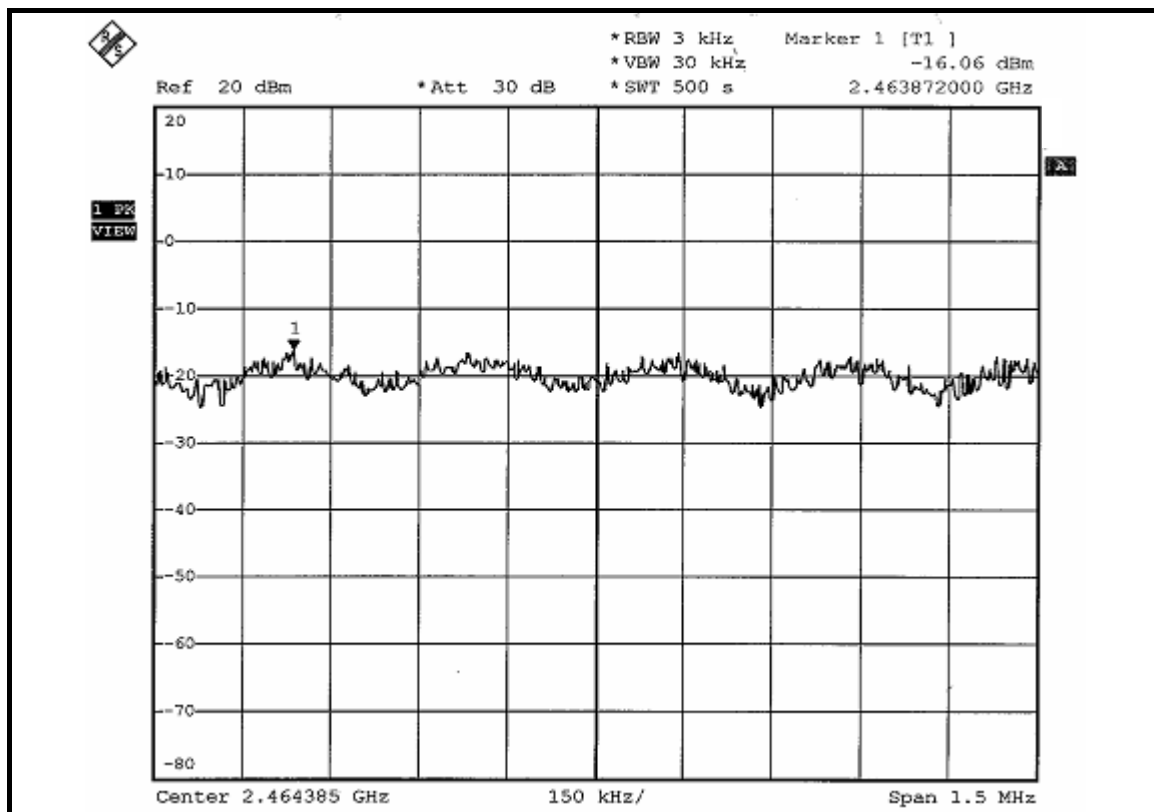

FOR CHAIN 1: CH 1

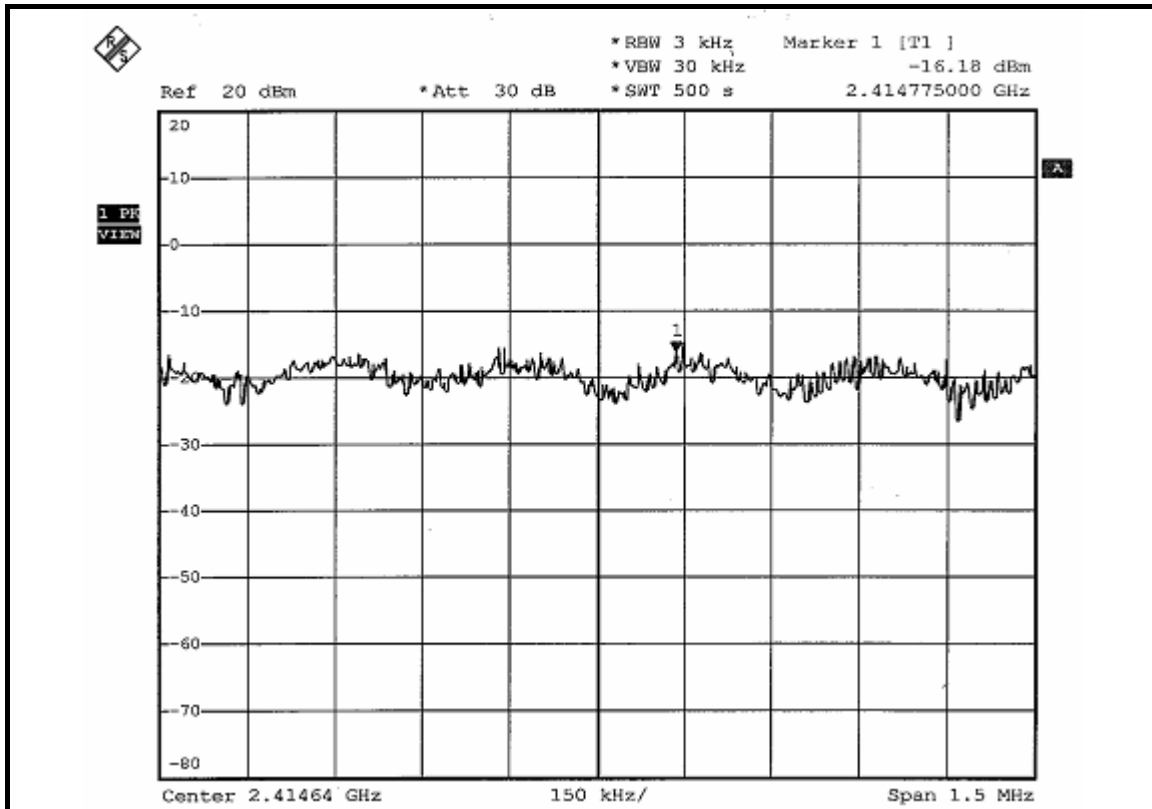

CH 6

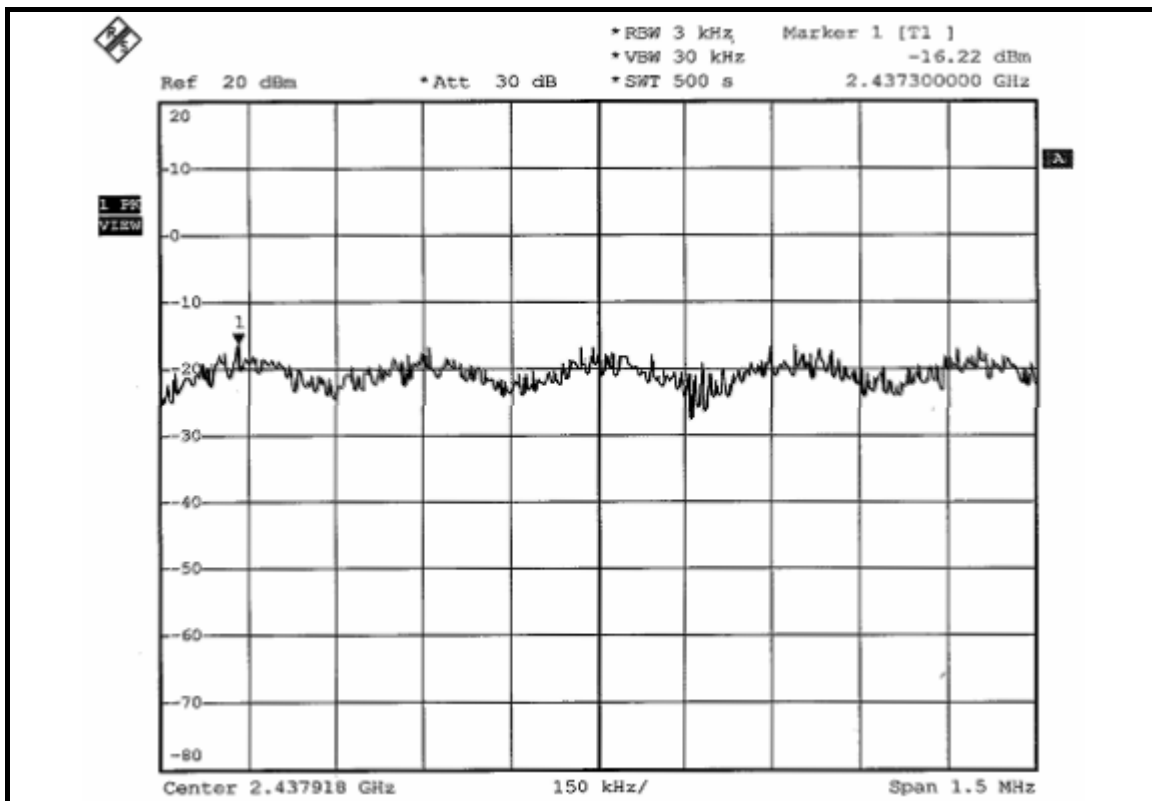

CH 11

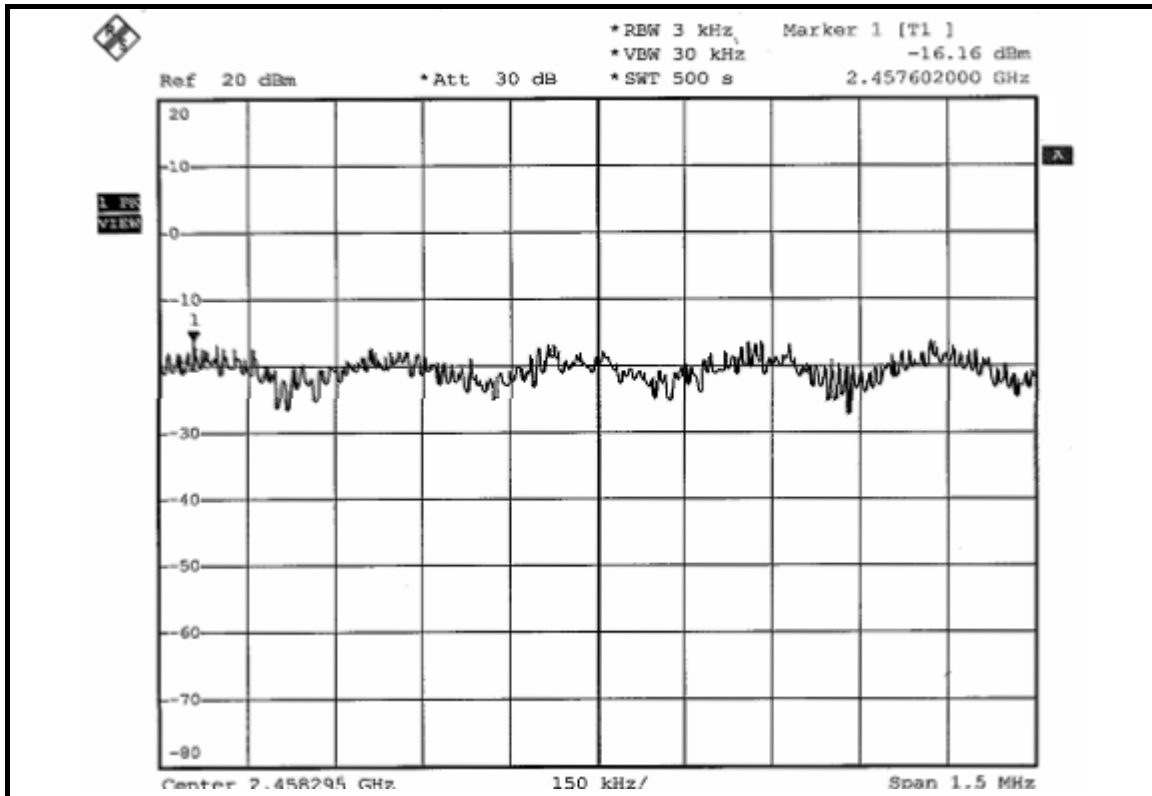



DRAFT 802.11n (20MHz) OFDM MODULATION: DUAL TX:

MODULATION TYPE	BPSK	TRANSFER RATE	7.2Mbps
INPUT POWER (SYSTEM)	120Vac, 60 Hz	ENVIRONMENTAL CONDITIONS	25deg.C, 63%RH, 991hPa
TESTED BY	Long Chen		

CHANNEL	CHANNEL FREQUENCY (MHz)	RF POWER LEVEL IN 3kHz BW (mW)		RF POWER LEVEL IN 3kHz BW (dBm)		TOTAL POWER DENSITY (mW)	TOTAL POWER DENSITY (dBm)	MAX. LIMIT (dBm)	PASS / FAIL
		CHAIN 0	CHAIN 1	CHAIN 0	CHAIN 1				
1	2412	0.022	0.021	-16.56	-16.81	0.043	-13.665	8	PASS
6	2437	0.036	0.035	-14.40	-14.55	0.071	-11.487	8	PASS
11	2462	0.036	0.035	-14.42	-14.52	0.071	-11.487	8	PASS

FOR CHAIN 0: CH 1

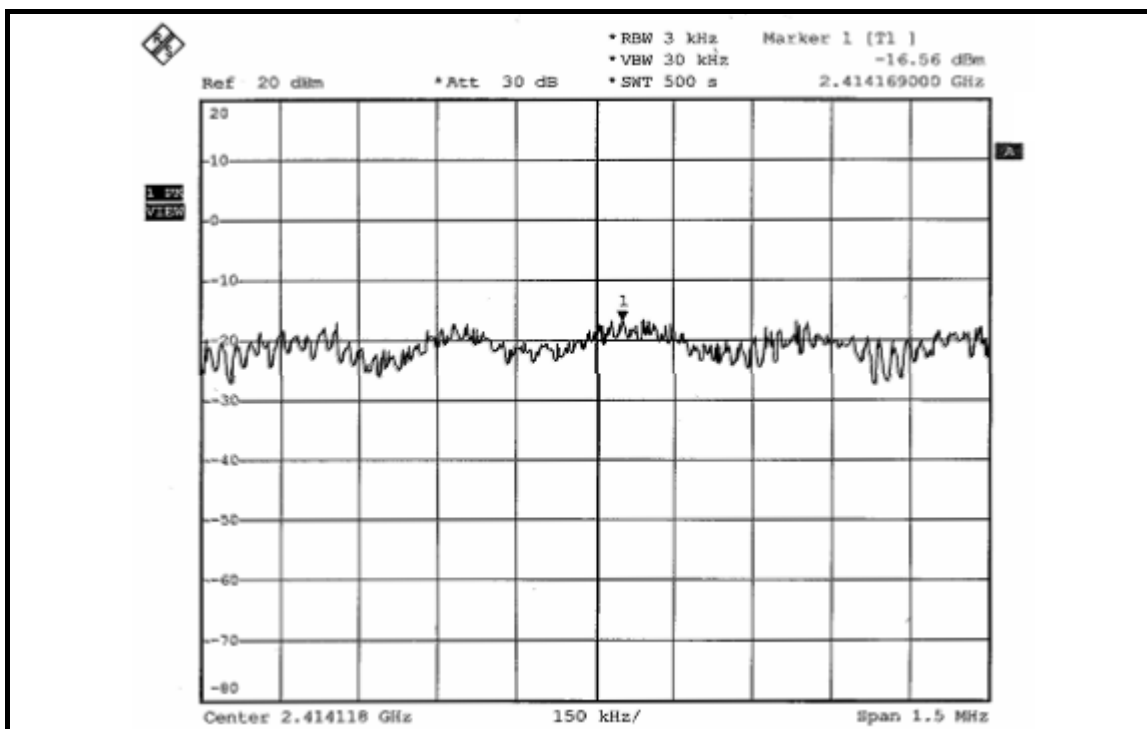

CH 11

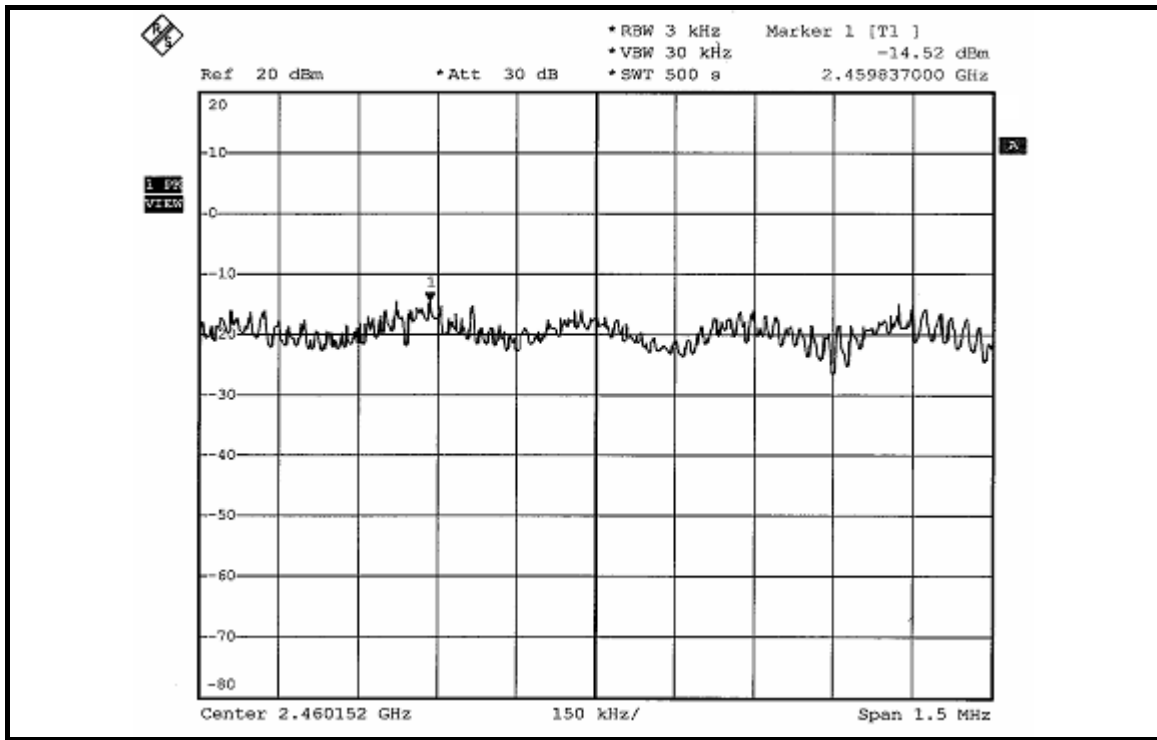



DRAFT 802.11n (40MHz) OFDM MODULATION: DUAL TX:

MODULATION TYPE	BPSK	TRANSFER RATE	15Mbps
INPUT POWER (SYSTEM)	120Vac, 60 Hz	ENVIRONMENTAL CONDITIONS	25deg.C, 63%RH, 991hPa
TESTED BY	Long Chen		

CHANNEL	CHANNEL FREQUENCY (MHz)	RF POWER LEVEL IN 3kHz BW (mW)		RF POWER LEVEL IN 3kHz BW (dBm)		TOTAL POWER DENSITY (mW)	TOTAL POWER DENSITY (dBm)	MAX. LIMIT (dBm)	PASS / FAIL
		CHAIN 0	CHAIN 1	CHAIN 0	CHAIN 1				
1	2422	0.007	0.007	-21.57	-21.85	0.013	-18.860	8	PASS
4	2437	0.011	0.011	-19.50	-19.73	0.022	-16.576	8	PASS
7	2452	0.009	0.009	-20.54	-20.67	0.017	-17.696	8	PASS

FOR CHAIN 0: CH 1

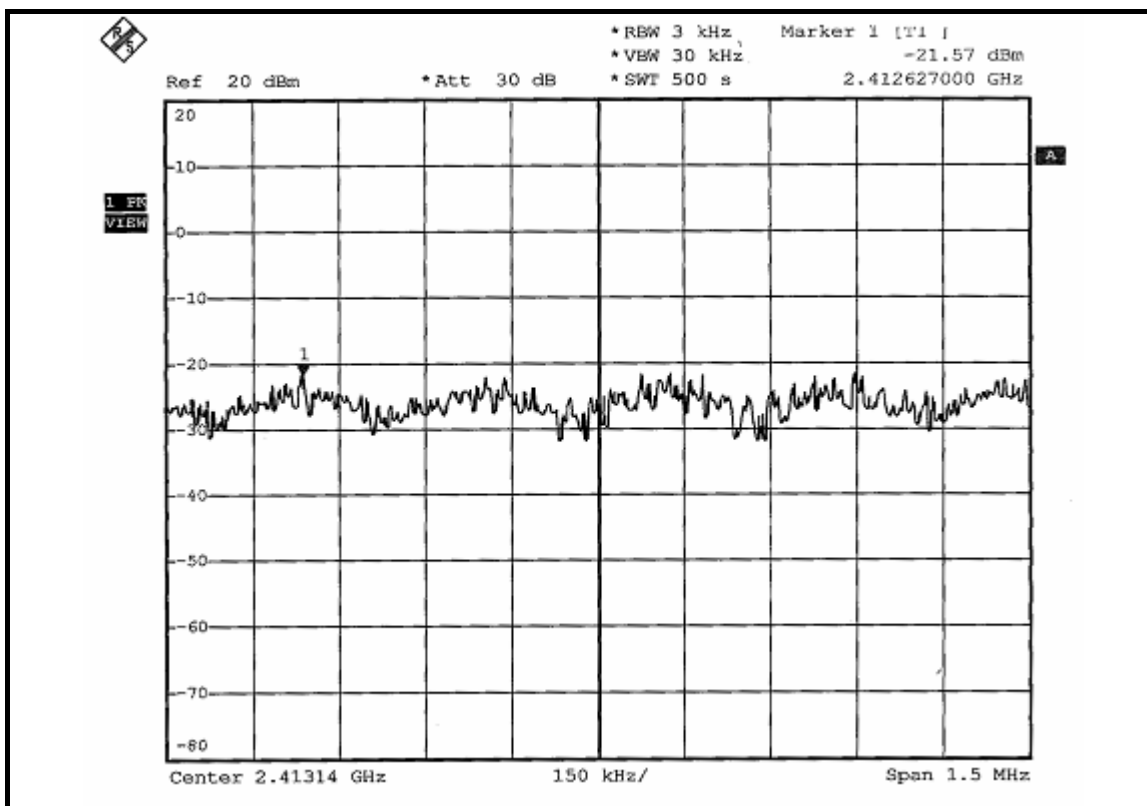

FOR CHAIN 1: CH 1

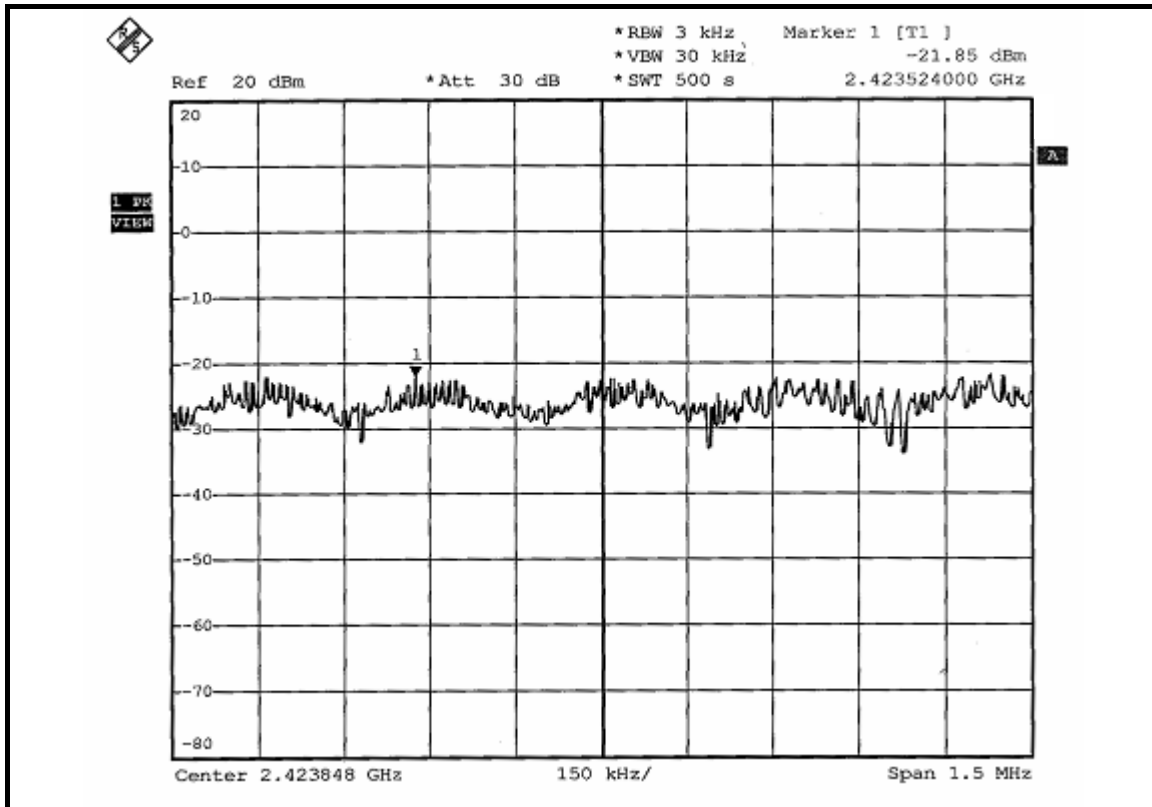

CH 4

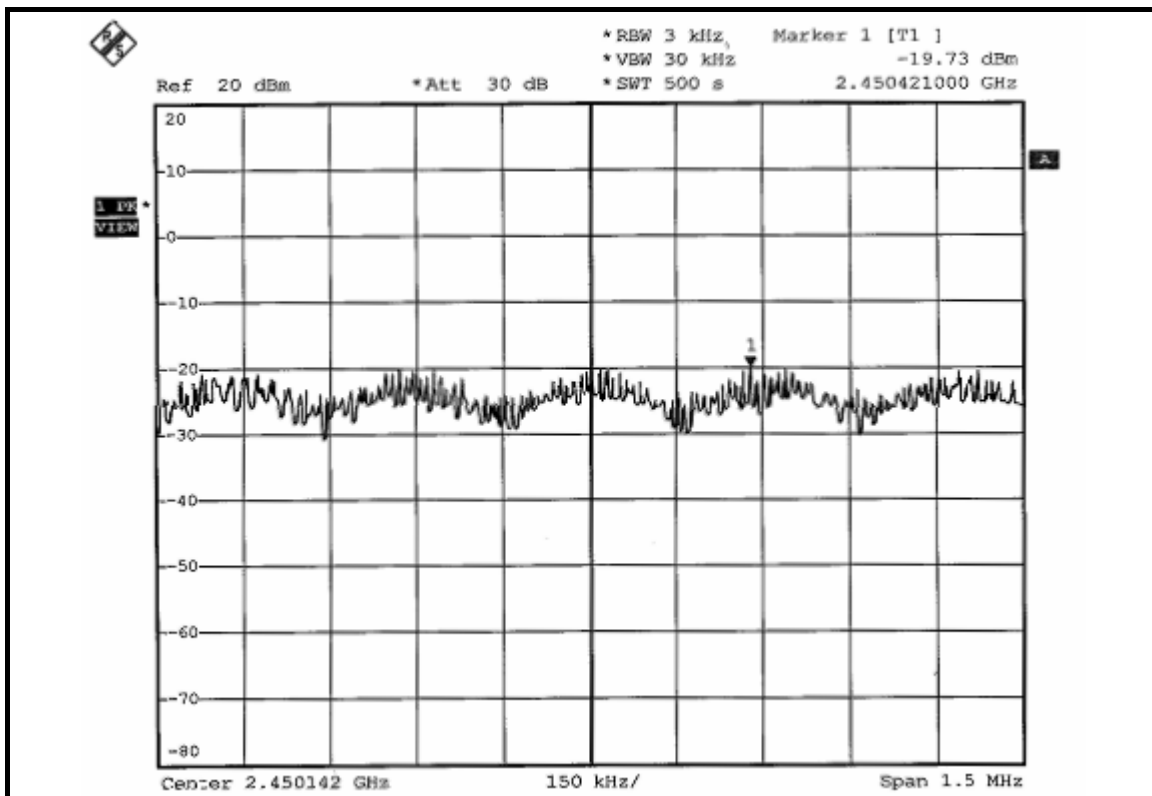

CH 7

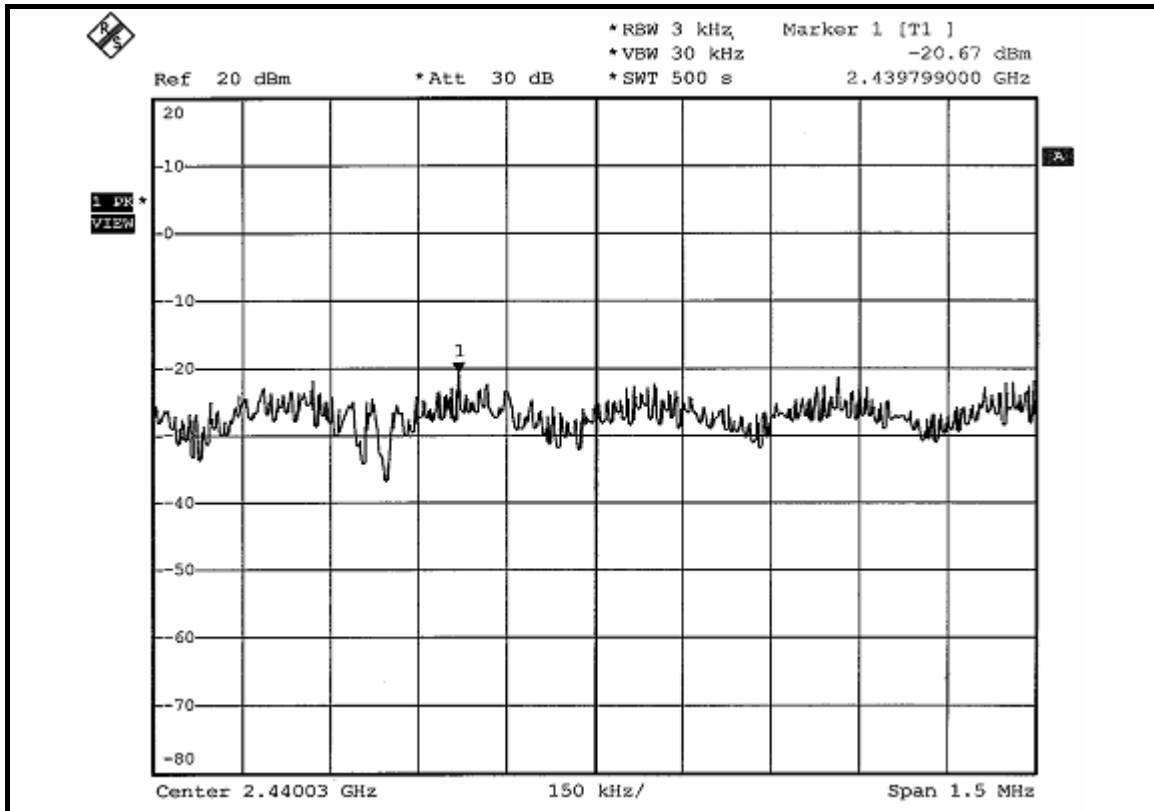



4.6 BAND EDGES MEASUREMENT

4.6.1 LIMITS OF BAND EDGES MEASUREMENT

Below -20dB of the highest emission level of operating band (in 100kHz Resolution Bandwidth).

4.6.2 TEST INSTRUMENTS

DESCRIPTION & MANUFACTURER	MODEL NO.	SERIAL NO.	CALIBRATED UNTIL
Spectrum Analyzer ROHDE & SCHWARZ	FSP40	100269	Aug. 07, 2007
BILOG Antenna SCHWARZBECK	VULB9168	9168-153	Jan. 04, 2008
HORN Antenna SCHWARZBECK	BBHA 9120 D	9120D-563	Jul. 26, 2007
HORN Antenna SCHWARZBECK	BBHA 9170	BBHA9170242	Jan. 16, 2008
RF signal cable HUBER+SUHNNER	SUCOFLEX 104	218188/218189	Nov. 14, 2007
RF signal cable Worken	8D-FB	Cable-HYCH9-01	Mar. 08, 2007
Software	ADT_Radiated_V7.6	NA	NA
Antenna Tower EMCO	2070/2080	512.835.4684	NA
Turn Table EMCO	2087-2.03	NA	NA
Antenna Tower & Turn Table Controller EMCO	2090	NA	NA

NOTE: 1. The calibration interval of the above test instruments is 12 months and the calibrations are traceable to NML/ROC and NIST/USA.

4.6.3 TEST PROCEDURE

- a. The EUT was placed on the top of a rotating table 0.8 meters above the ground at a 3 meter semi-anechoic chamber. The table was rotated 360 degrees to determine the position of the highest radiation.
- b. The EUT was set 3 meters away from the interference-receiving antenna, which was mounted on the top of a variable-height antenna tower.
- c. The antenna is a broadband antenna, and its height is varied from one meter to four meters above the ground to determine the maximum value of the field strength. Both horizontal and vertical polarizations of the antenna are set to make the measurement.
- d. For each suspected emission, the EUT was arranged to its worst case and then the antenna was tuned to heights from 1 meter to 4 meters and the rotatable table was turned from 0 degrees to 360 degrees to find the maximum reading.
- e. Set both RBW and VBW of spectrum analyzer to 100kHz with suitable frequency span including 100MHz bandwidth from band edge. The band edges was measured and recorded.

The spectrum plots (Peak RBW = VBW = 100kHz; Average RBW = 1MHz, VBW = 10Hz)

NOTE: The resolution bandwidth of test receiver/spectrum analyzer is 1 MHz and the video bandwidth is 10Hz for Average detection (AV) at frequency above 1GHz.

4.6.4 DEVIATION FROM TEST STANDARD

No deviation

4.6.5 EUT OPERATING CONDITION

Same as Item 4.3.6.

4.6.6 TEST RESULTS

The spectrum plots are attached on the following 24 images. D1 line indicates the highest level, and D2 line indicates the 20dB offset below D1. It shows compliance with the requirement in part 15.247(d).

802.11b DSSS MODULATION:

NOTE 1:

The band edge emission plot of DSSS technique on the next page shows 55.86dBc between carrier maximum power and local maximum emission in restrict band (2.3328GHz). The emission of carrier strength list in the test result of channel 1 at the item 4.2.7 is 112.54dBuV/m (Peak), so the maximum field strength in restrict band is $112.54 - 55.86 = 56.68$ dBuV/m which is under 74dBuV/m limit.

The band edge emission plot of DSSS technique on the next page shows 66.07dBc between carrier maximum power and local maximum emission in restrict band (2.3900GHz). The emission of carrier strength list in the test result of channel 1 at the item 4.2.7 is 108.04dBuV/m (Average), so the maximum field strength in restrict band is $108.04 - 66.07 = 41.97$ dBuV/m which is under 54dBuV/m limit.

NOTE 2:

The band edge emission plot of DSSS technique on the next second page shows 56.53dBc between carrier maximum power and local maximum emission in restrict band (2.4880GHz). The emission of carrier strength list in the test result of channel 11 at the item 4.2.7 is 115.08dBuV/m (Peak), so the maximum field strength in restrict band is $115.08 - 56.53 = 58.55$ dBuV/m which is under 74dBuV/m limit.

The band edge emission plot of DSSS technique on the next third page shows 59.83dBc between carrier maximum power and local maximum emission in restrict band (2.4878GHz). The emission of carrier strength list in the test result of channel 11 at the item 4.2.7 is 110.61dBuV/m (Average), so the maximum field strength in restrict band is $110.61 - 59.83 = 50.78$ dBuV/m which is under 54dBuV/m limit.

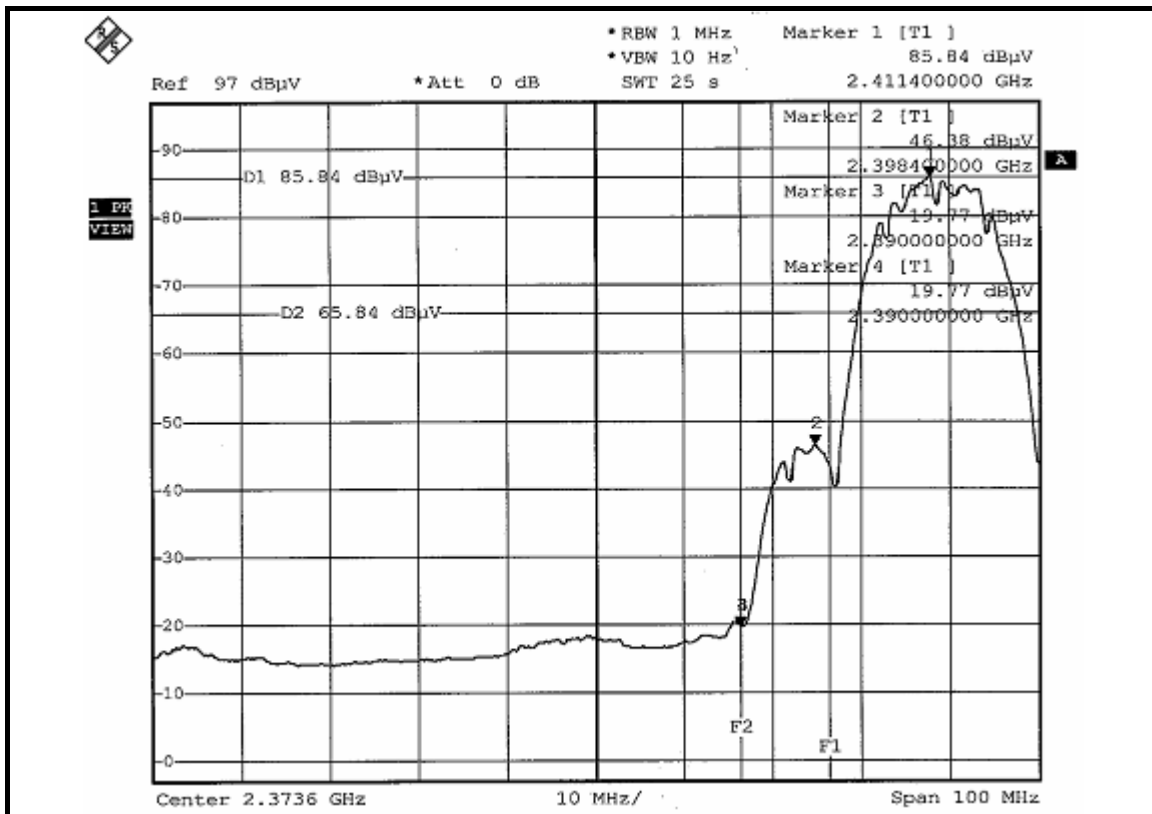
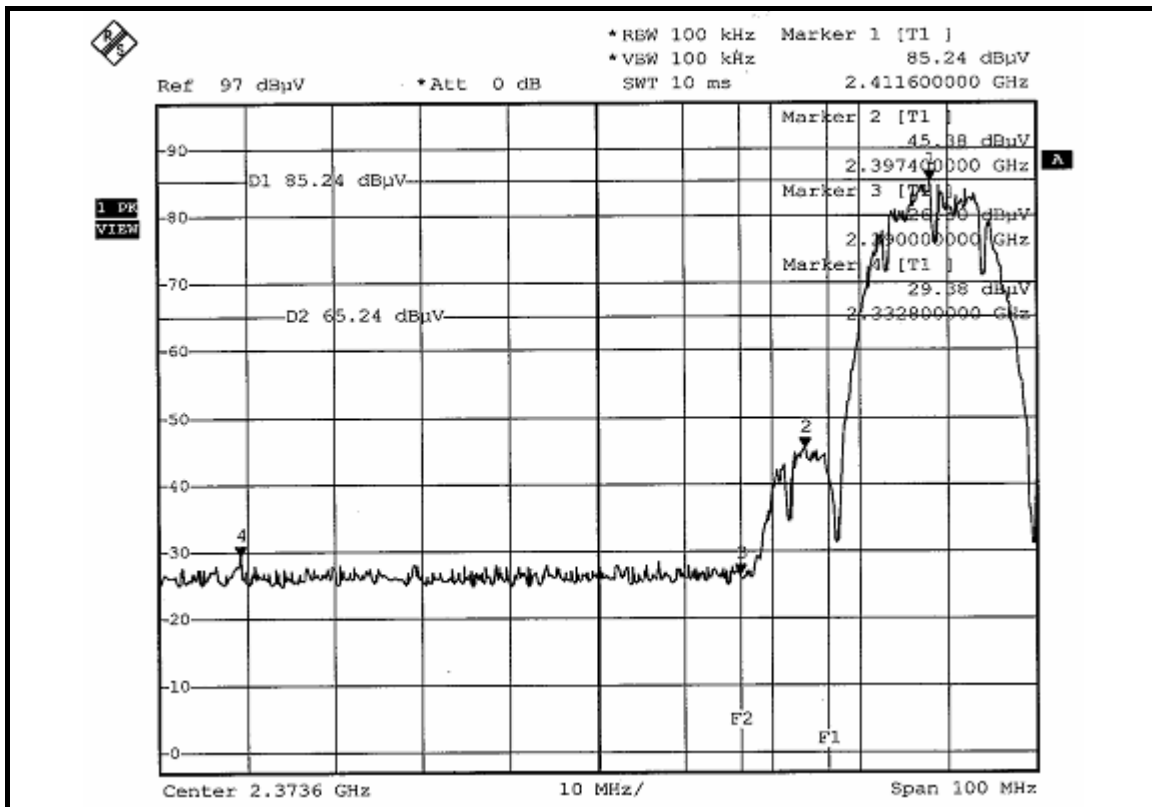

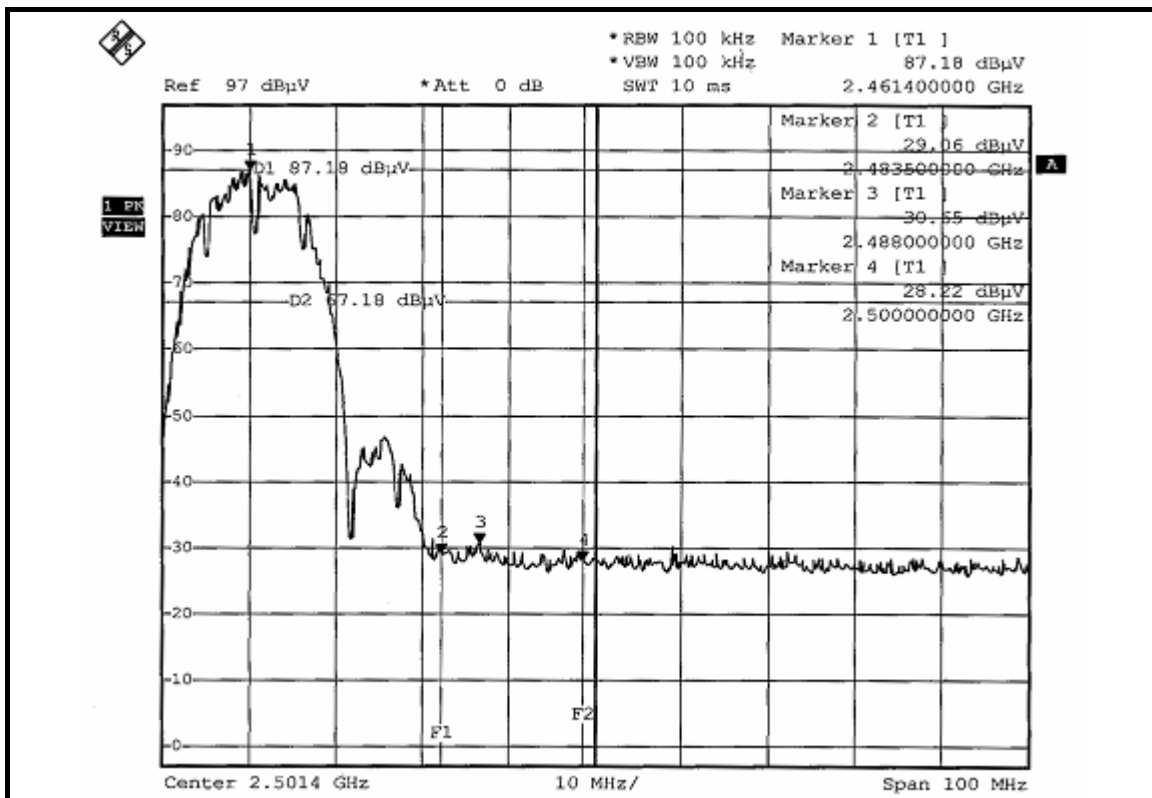
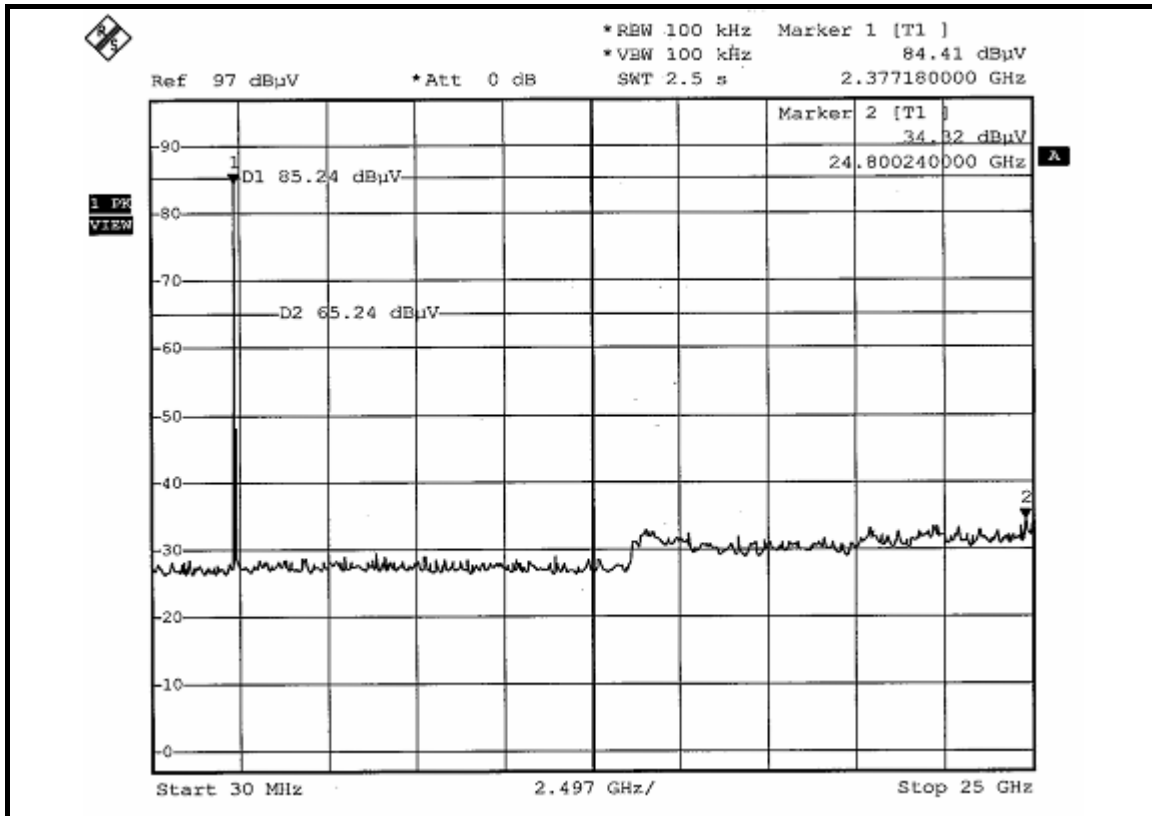

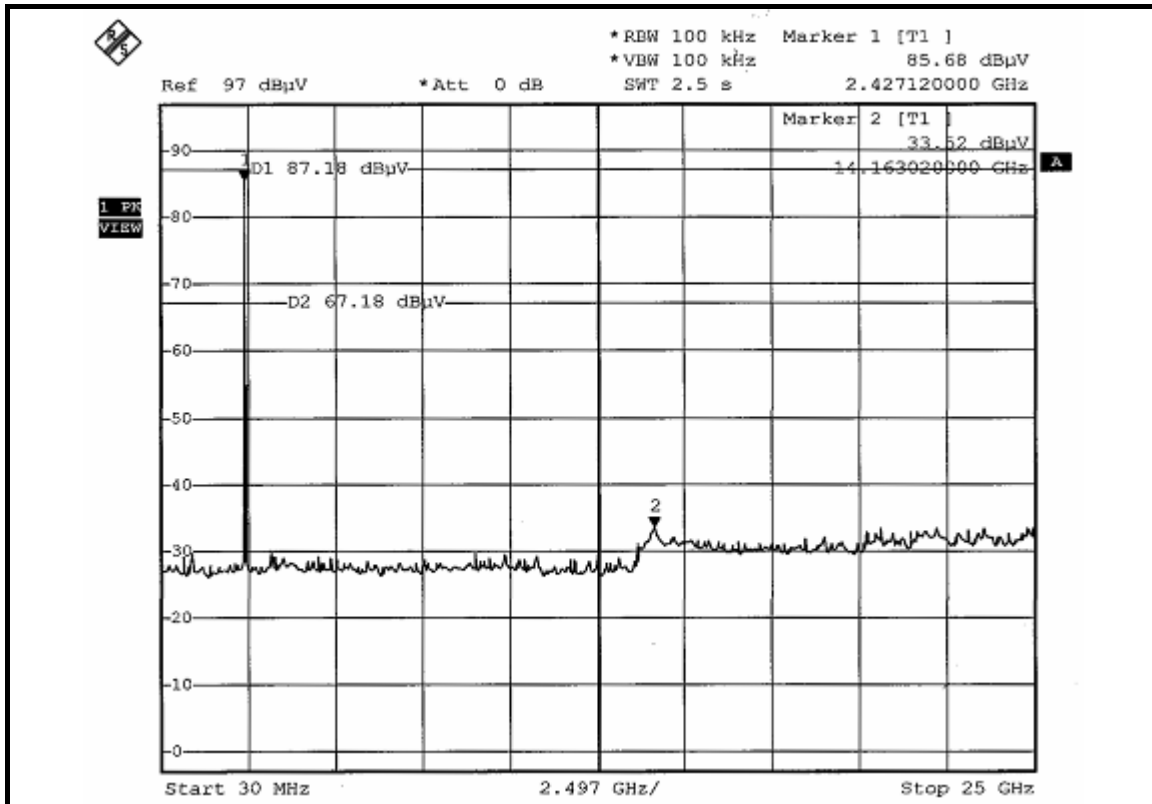
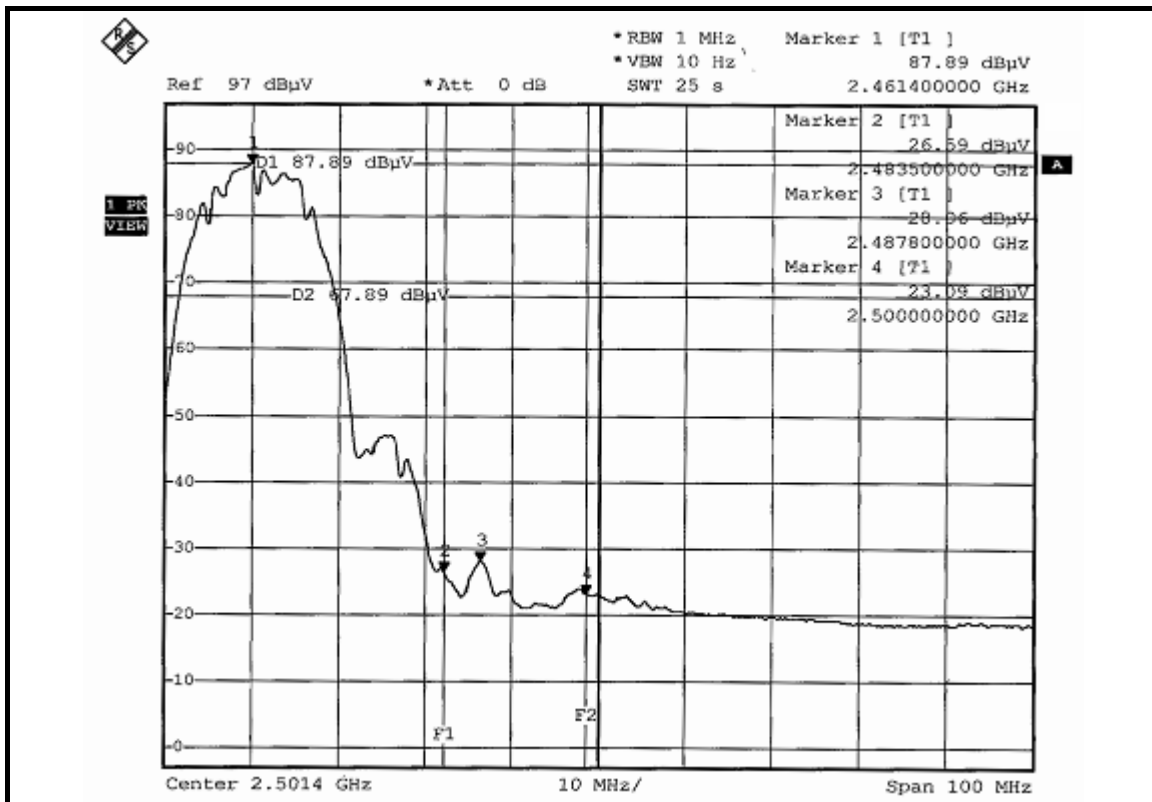

802.11g OFDM MODULATION:

NOTE 1:

The band edge emission plot of OFDM technique on the next page shows 47.61dBc between carrier maximum power and local maximum emission in restrict band (2.3900GHz). The emission of carrier strength list in the test result of channel 1 at the item 4.2.7 is 114.00dBuV/m (Peak), so the maximum field strength in restrict band is $114.00-47.61=66.39\text{dBuV/m}$ which is under 74dBuV/m limit.

The band edge emission plot of OFDM technique on the next page shows 51.21dBc between carrier maximum power and local maximum emission in restrict band (2.3900GHz). The emission of carrier strength list in the test result of channel 1 at the item 4.2.7 is 104.15dBuV/m (Average), so the maximum field strength in restrict band is $104.15-51.21=52.94\text{dBuV/m}$ which is under 54dBuV/m limit.

NOTE 2:

The band edge emission plot of OFDM technique on the next second page shows 49.44dBc between carrier maximum power and local maximum emission in restrict band (2.4858GHz). The emission of carrier strength list in the test result of channel 11 at the item 4.2.7 is 114.32dBuV/m (Peak), so the maximum field strength in restrict band is $114.32-49.44=64.88\text{dBuV/m}$ which is under 74dBuV/m limit.

The band edge emission plot of OFDM technique on the next third page shows 53.52dBc between carrier maximum power and local maximum emission in restrict band (2.4835GHz). The emission of carrier strength list in the test result of channel 11 at the item 4.2.7 is 104.62dBuV/m (Average), so the maximum field strength in restrict band is $104.62-53.52=51.10\text{dBuV/m}$ which is under 54dBuV/m limit.

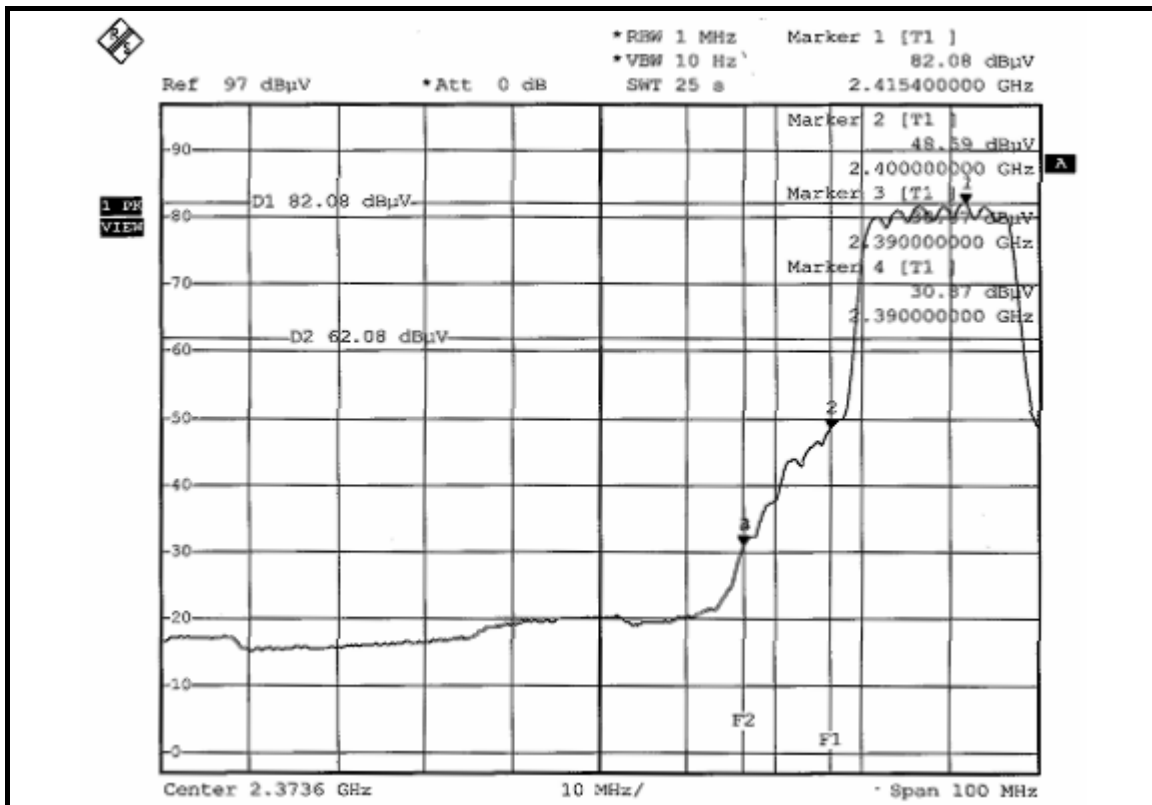
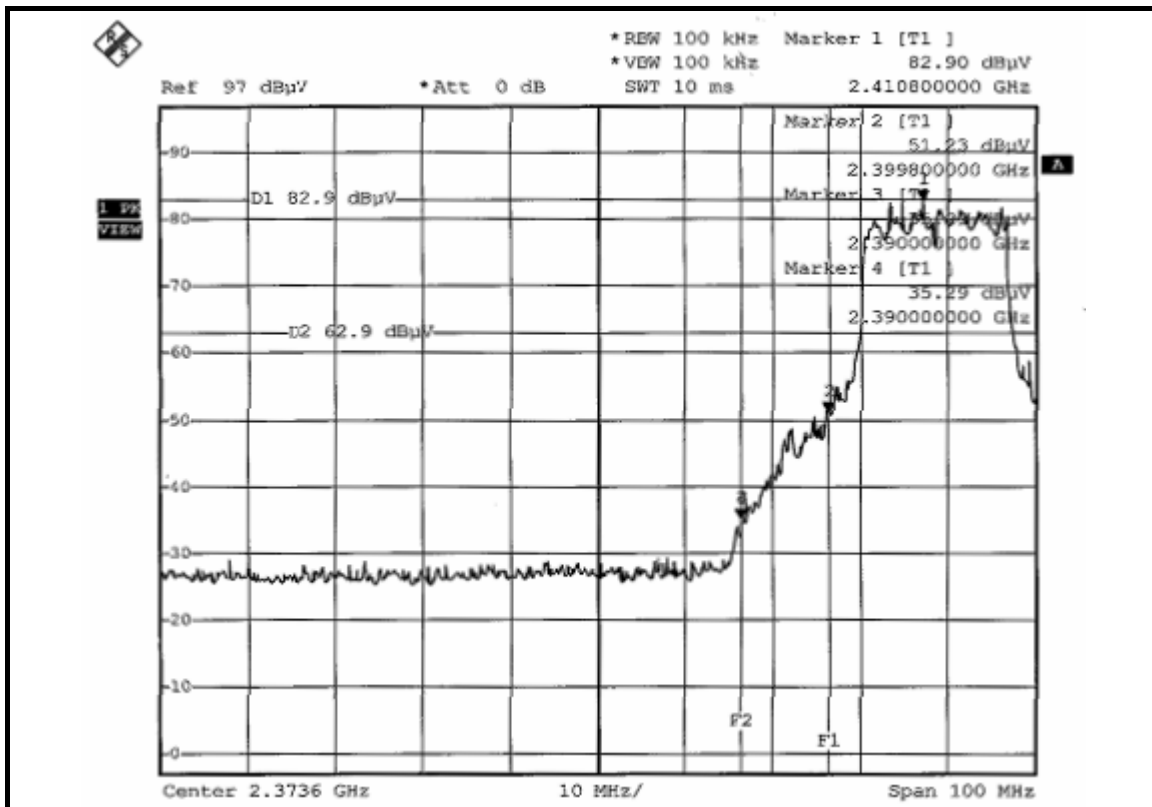

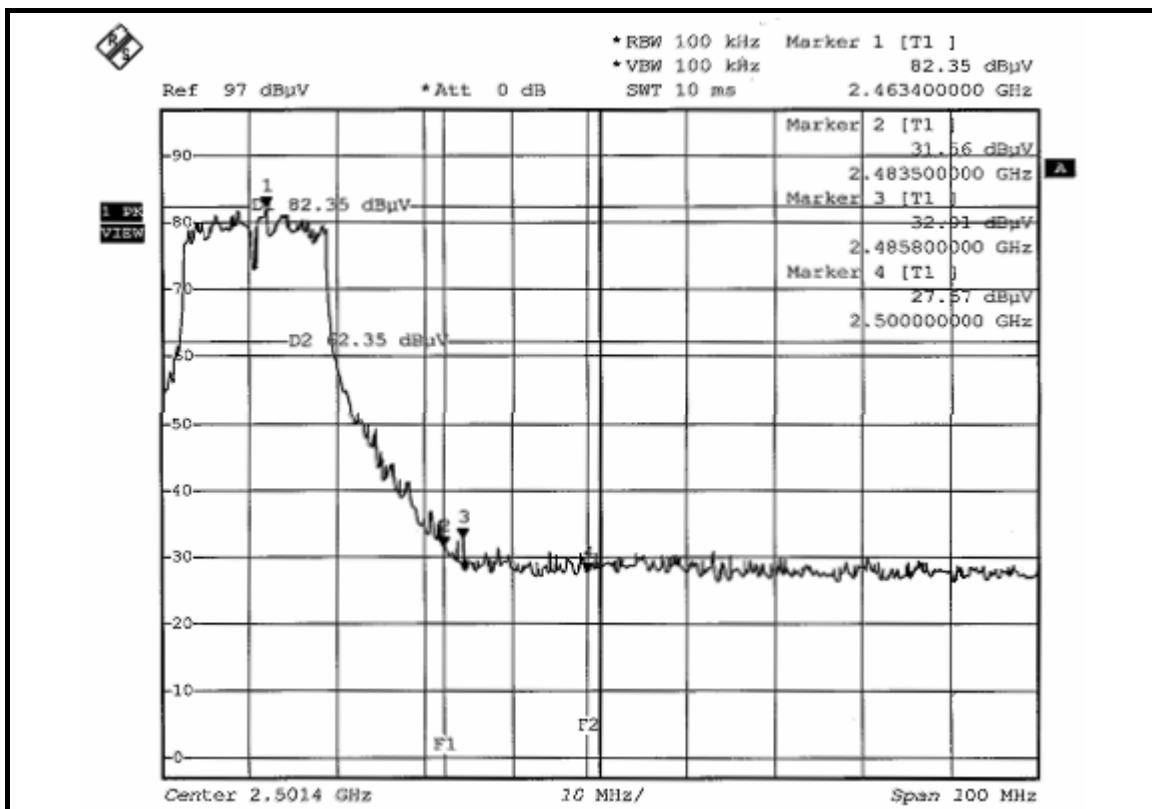
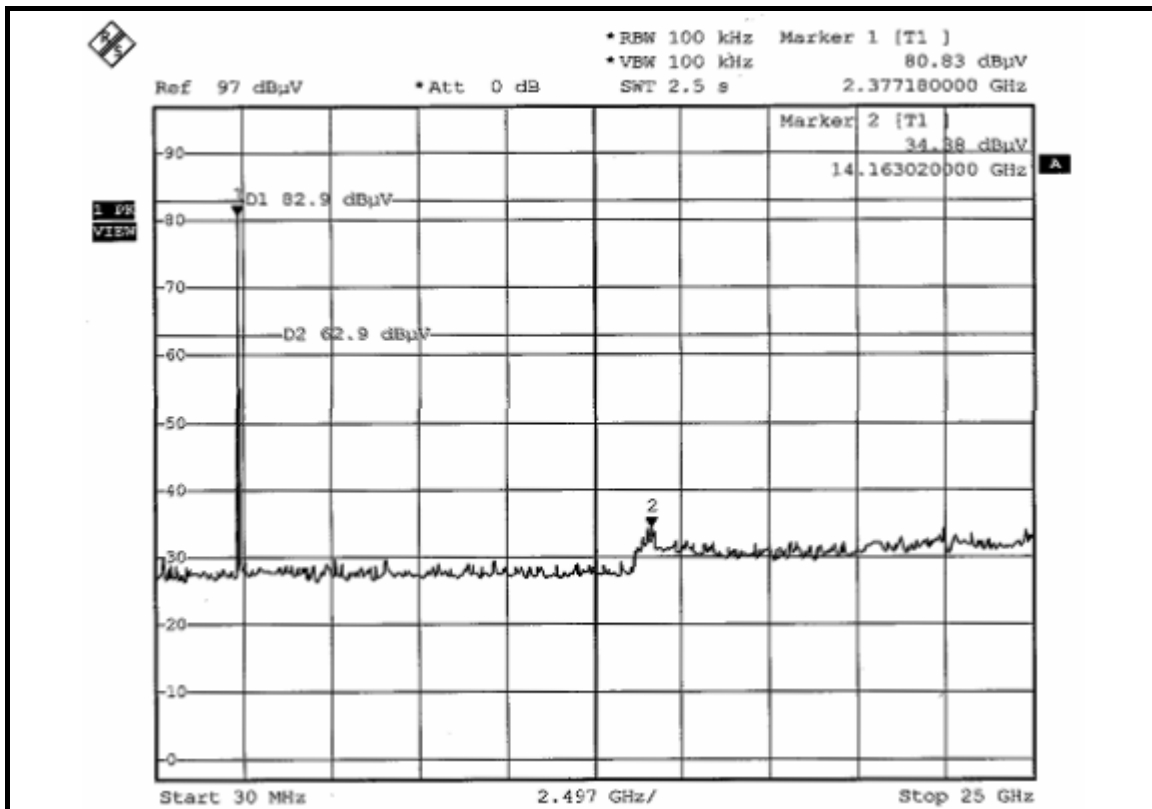

DRAFT 802.11n (20MHz) OFDM MODULATION: DUAL TX:

NOTE 1:

The band edge emission plot of OFDM technique on the next page shows 48.69dBc between carrier maximum power and local maximum emission in restrict band (2.3900GHz). The emission of carrier strength list in the test result of channel 1 at the item 4.2.7 is 112.50dBuV/m (Peak), so the maximum field strength in restrict band is $112.50 - 48.69 = 63.81$ dBuV/m which is under 74dBuV/m limit.

The band edge emission plot of OFDM technique on the next page shows 51.62dBc between carrier maximum power and local maximum emission in restrict band (2.3900GHz). The emission of carrier strength list in the test result of channel 1 at the item 4.2.7 is 102.46dBuV/m (Average), so the maximum field strength in restrict band is $102.46 - 51.62 = 50.84$ dBuV/m which is under 54dBuV/m limit.

NOTE 2:

The band edge emission plot of OFDM technique on the next second page shows 49.64dBc between carrier maximum power and local maximum emission in restrict band (2.4835GHz). The emission of carrier strength list in the test result of channel 11 at the item 4.2.7 is 114.82dBuV/m (Peak), so the maximum field strength in restrict band is $114.82 - 49.64 = 65.18$ dBuV/m which is under 74dBuV/m limit.

The band edge emission plot of OFDM technique on the next third page shows 52.08dBc between carrier maximum power and local maximum emission in restrict band (2.4835GHz). The emission of carrier strength list in the test result of channel 11 at the item 4.2.7 is 104.48dBuV/m (Average), so the maximum field strength in restrict band is $104.48 - 52.08 = 52.40$ dBuV/m which is under 54dBuV/m limit.

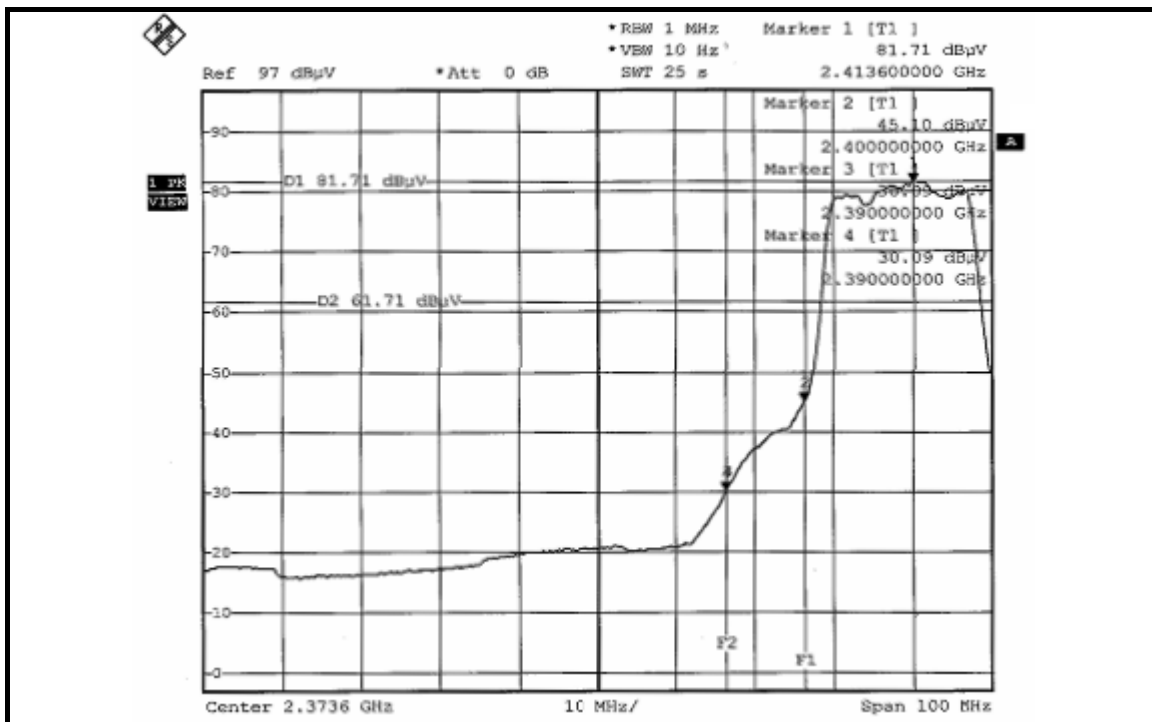
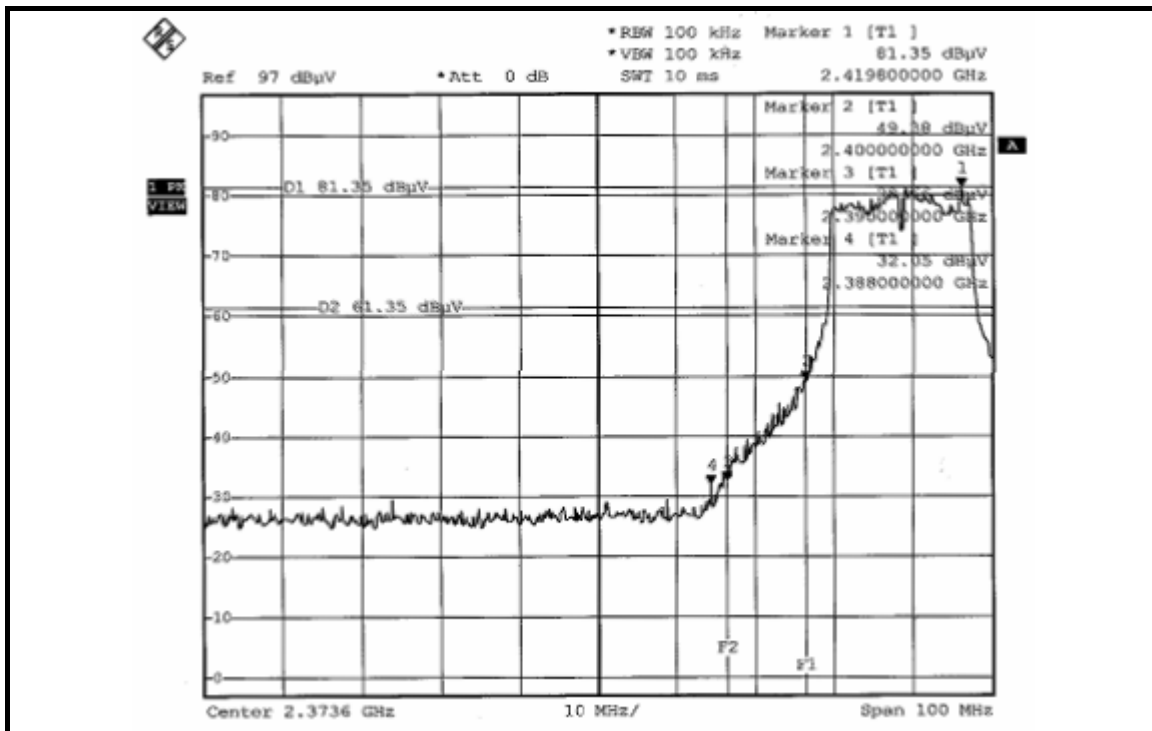

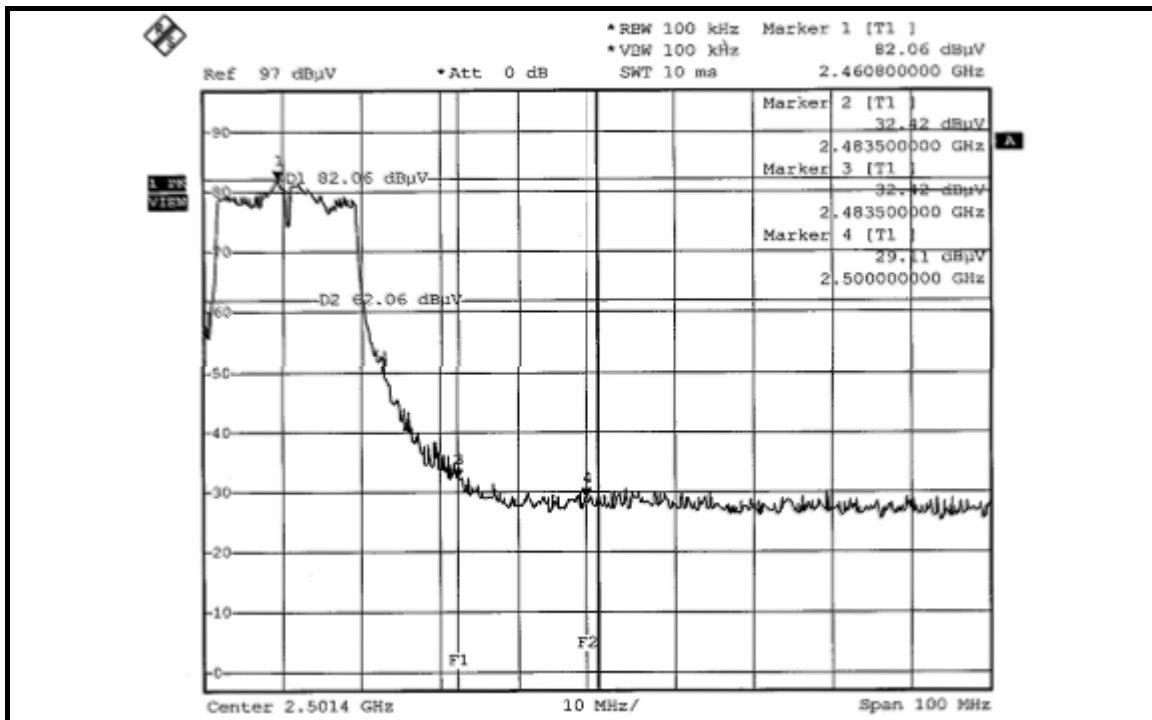
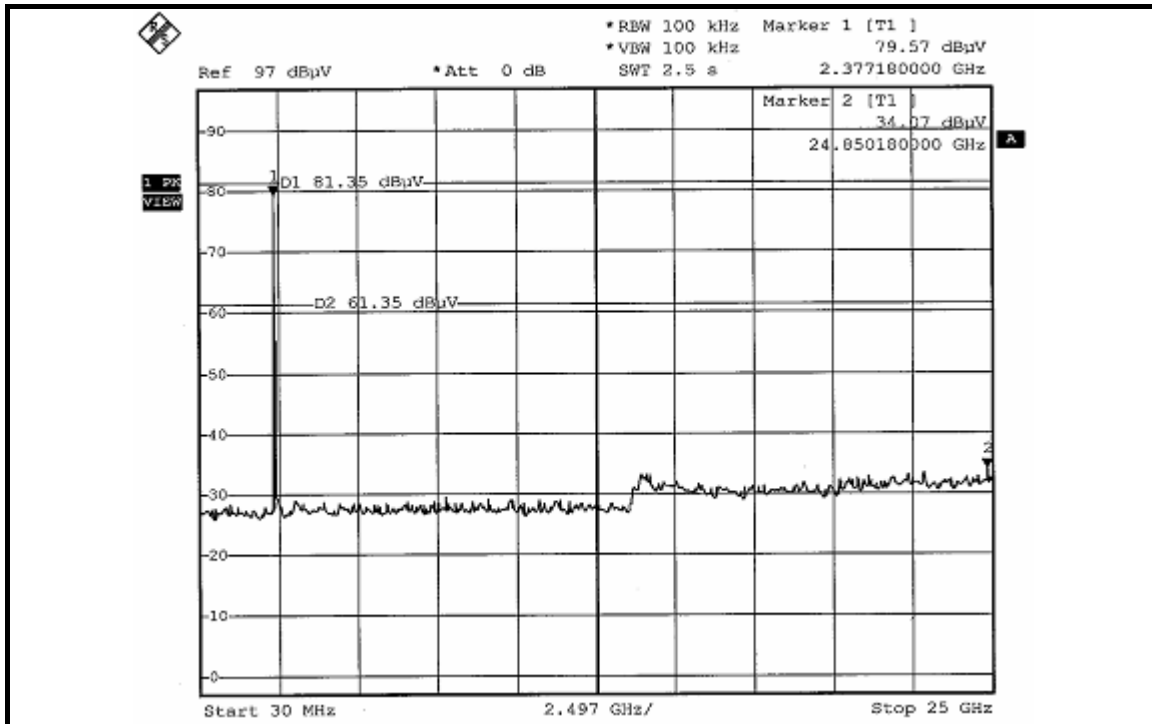

DRAFT 802.11n (40MHz) OFDM MODULATION: DUAL TX:

NOTE 1:

The band edge emission plot of OFDM technique on the next page shows 42.42dBc between carrier maximum power and local maximum emission in restrict band (2.3852GHz). The emission of carrier strength list in the test result of channel 1 at the item 4.2.7 is 106.97dBuV/m (Peak), so the maximum field strength in restrict band is $106.97 - 42.42 = 64.55$ dBuV/m which is under 74dBuV/m limit.

The band edge emission plot of OFDM technique on the next page shows 46.42dBc between carrier maximum power and local maximum emission in restrict band (2.3900GHz). The emission of carrier strength list in the test result of channel 1 at the item 4.2.7 is 96.85dBuV/m (Average), so the maximum field strength in restrict band is $96.85 - 46.42 = 50.43$ dBuV/m which is under 54dBuV/m limit.

NOTE 2:

The band edge emission plot of OFDM technique on the next second page shows 43.43dBc between carrier maximum power and local maximum emission in restrict band (2.4850GHz). The emission of carrier strength list in the test result of channel 7 at the item 4.2.7 is 107.51dBuV/m (Peak), so the maximum field strength in restrict band is $107.51 - 43.43 = 64.08$ dBuV/m which is under 74dBuV/m limit.

The band edge emission plot of OFDM technique on the next third page shows 45.53dBc between carrier maximum power and local maximum emission in restrict band (2.4835GHz). The emission of carrier strength list in the test result of channel 7 at the item 4.2.7 is 98.00dBuV/m (Average), so the maximum field strength in restrict band is $98.00 - 45.53 = 52.47$ dBuV/m which is under 54dBuV/m limit.

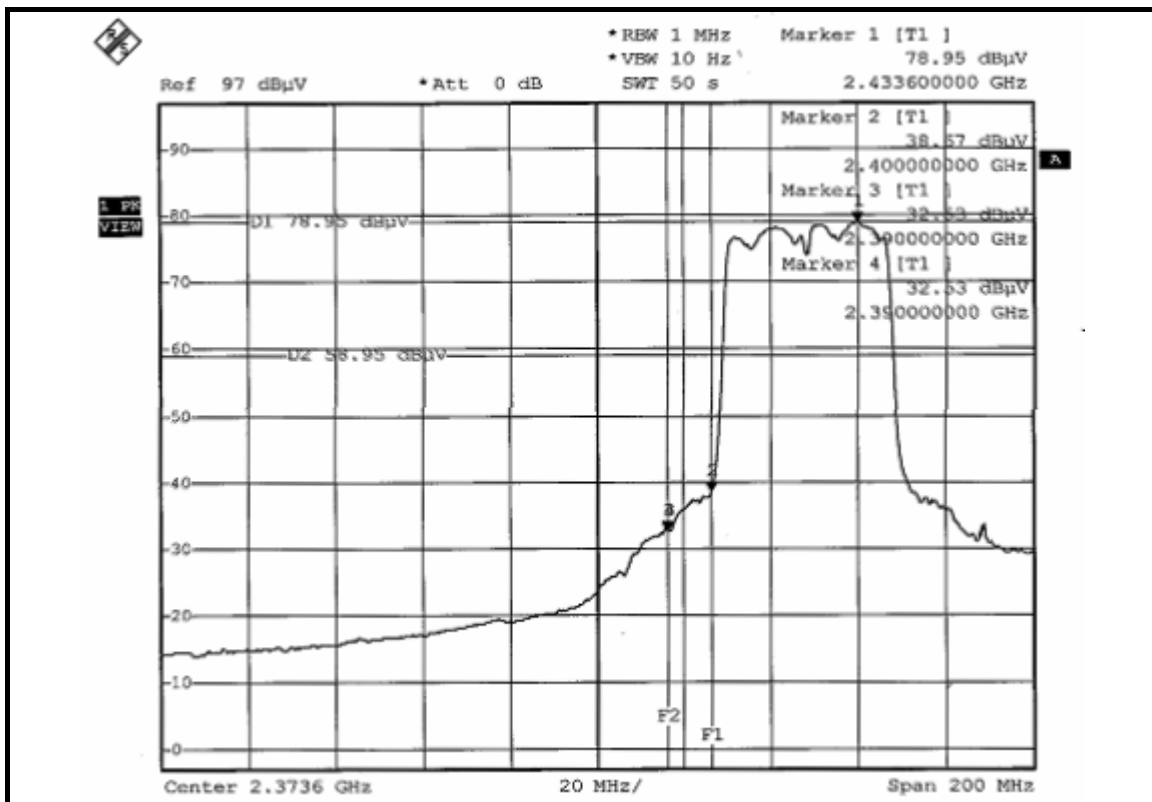
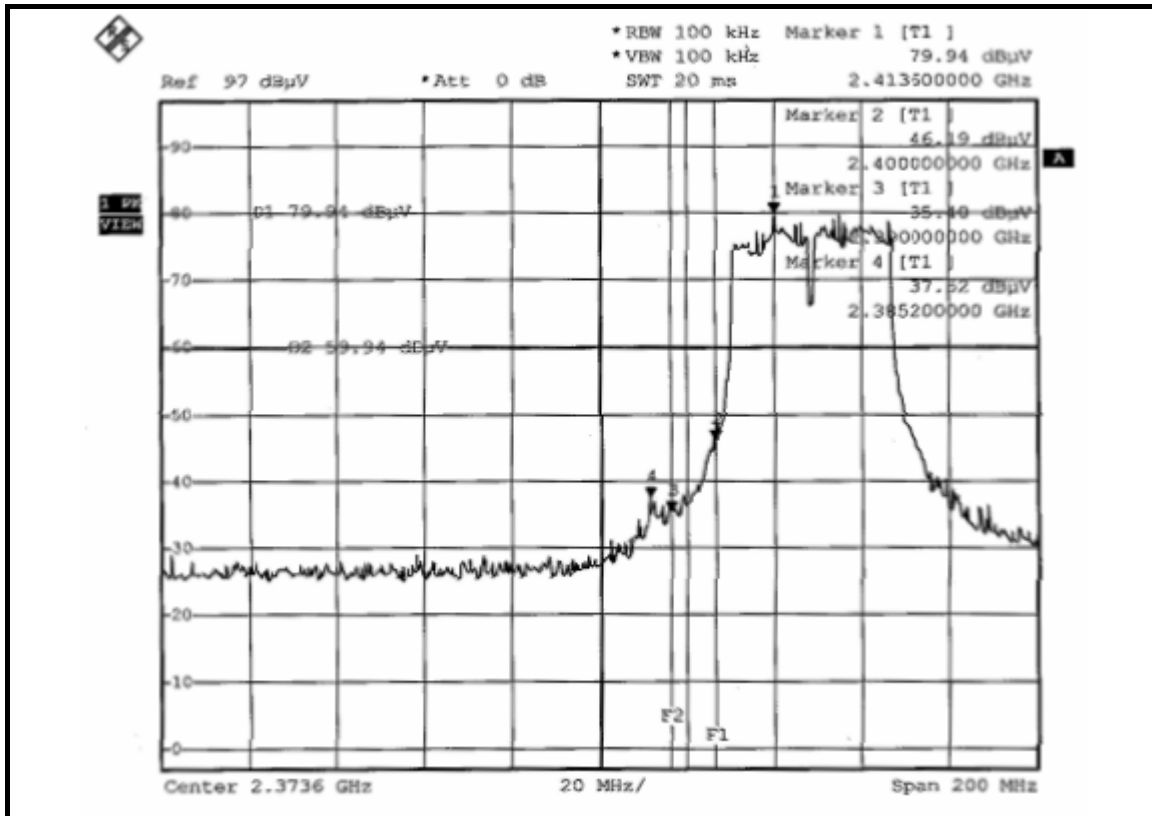

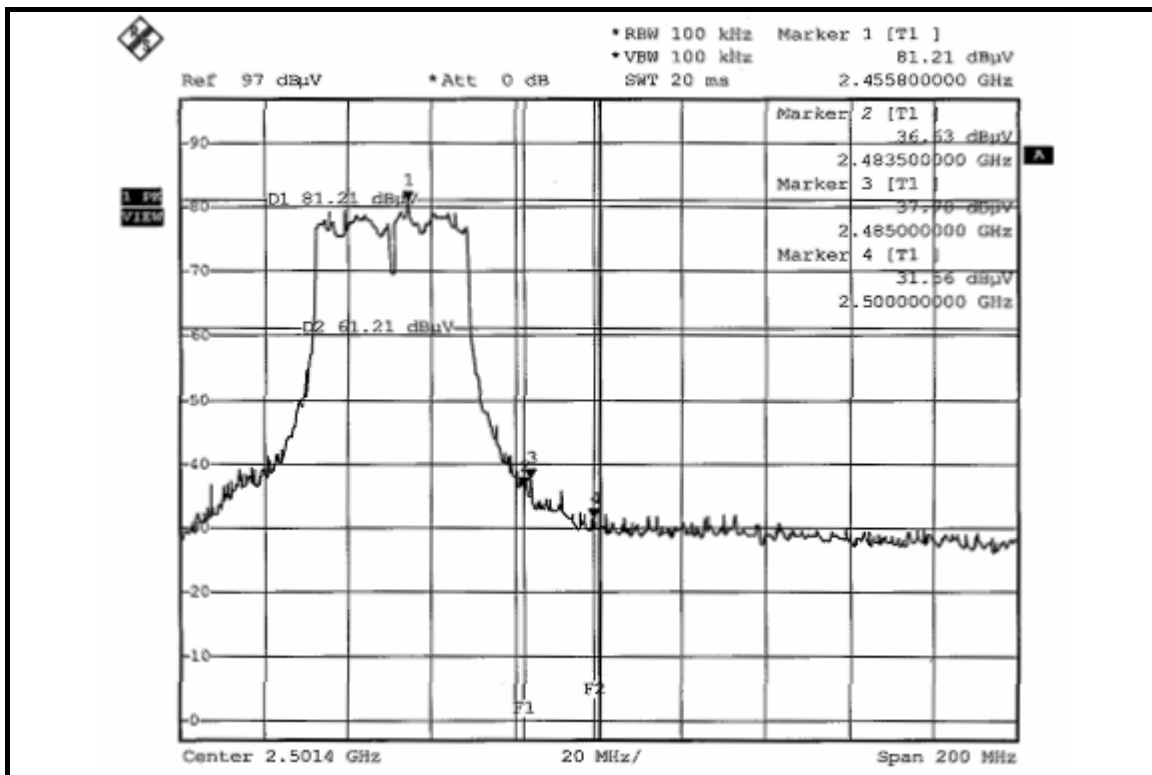
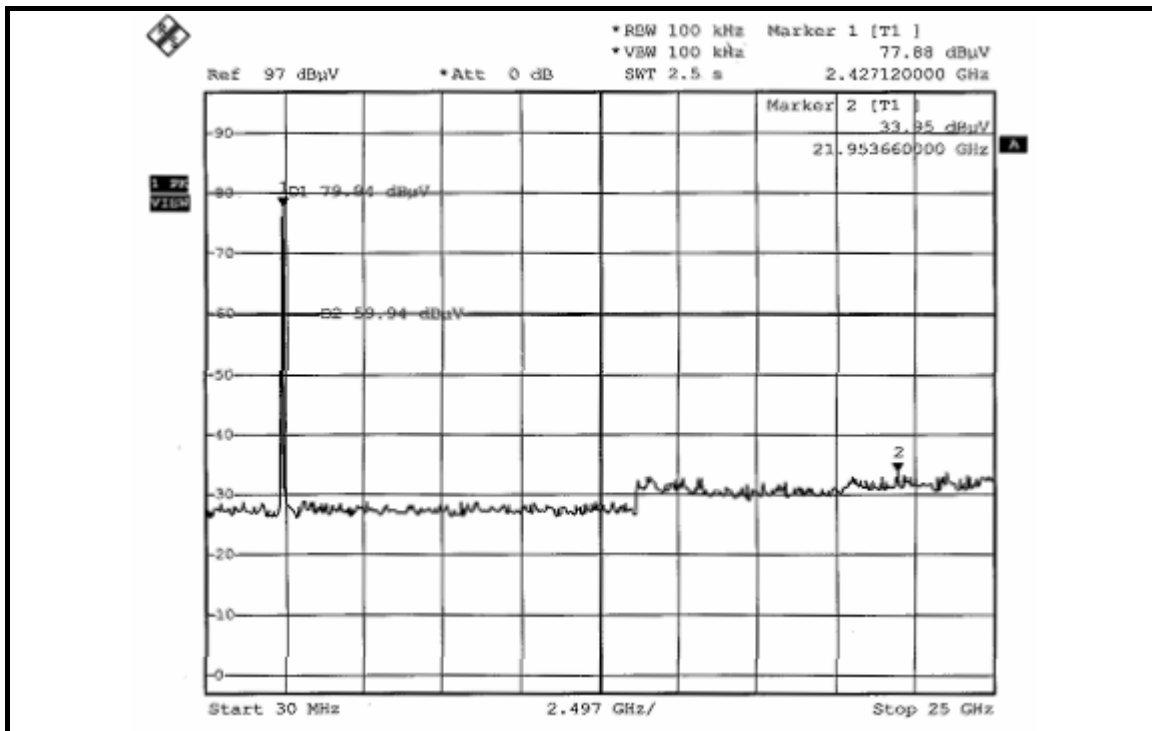

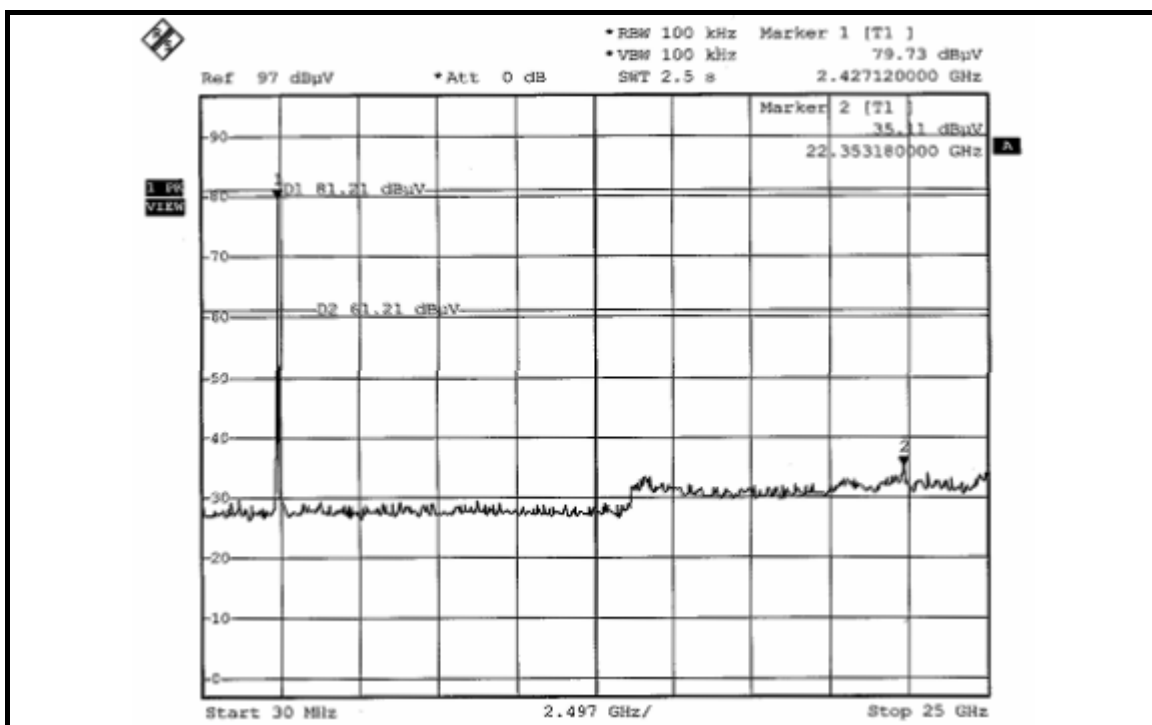
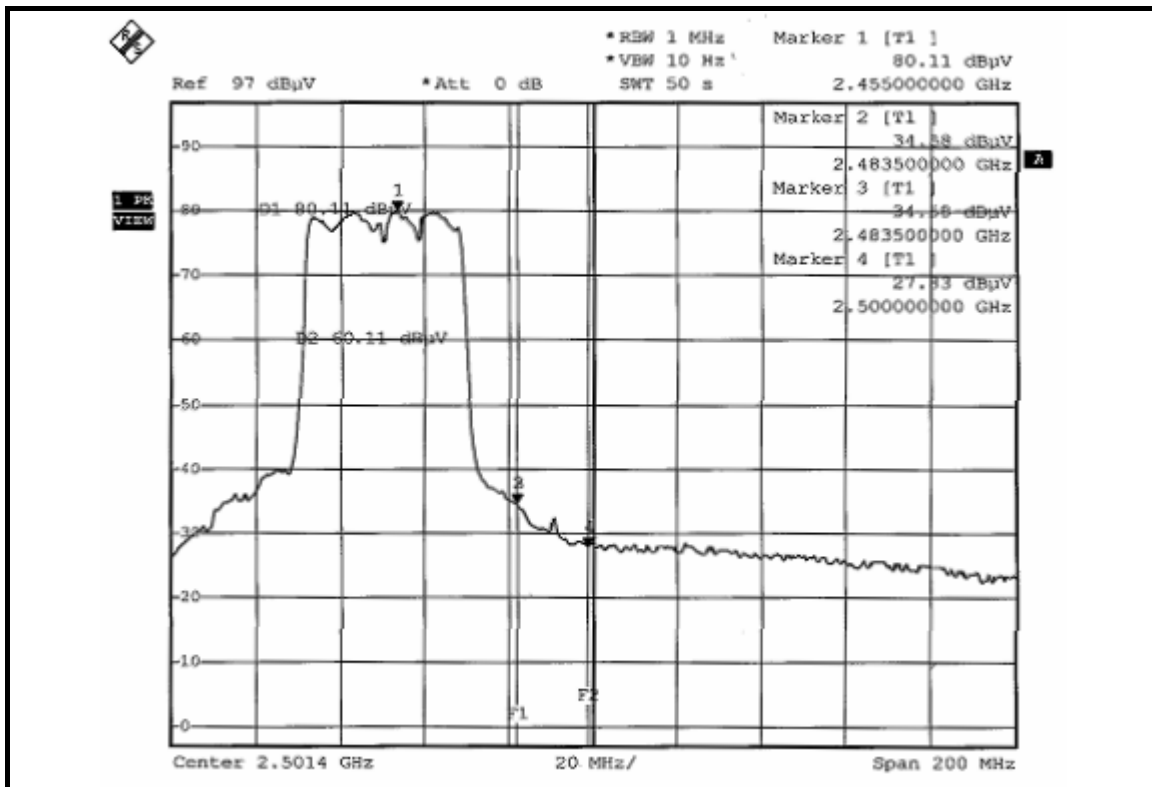

4.7 ANTENNA REQUIREMENT

4.7.1 STANDARD APPLICABLE

For intentional device, according to FCC 47 CFR Section 15.203, an intentional radiator shall be designed to ensure that no antenna other than that furnished by the responsible party shall be used with the device. And according to FCC 47 CFR Section 15.247 (b), if transmitting antennas of directional gain greater than 6dBi are used, the power shall be reduced by the amount in dB that the directional gain of the antenna exceeds 6dBi.

4.7.2 ANTENNA CONNECTED CONSTRUCTION

The antenna used in this product is Dipole antenna with R-SMA connector. The maximum Gain of the antenna is 2.0dBi.



5. PHOTOGRAPHS OF THE TEST CONFIGURATION

Please refer to the attached file (Test Setup Photo).



6. INFORMATION ON THE TESTING LABORATORIES

We, ADT Corp., were founded in 1988 to provide our best service in EMC, Radio, Telecom and Safety consultation. Our laboratories are accredited and approved by the following approval agencies according to ISO/IEC 17025.

USA	FCC, UL, A2LA
Germany	TUV Rheinland
Japan	VCCI
Norway	NEMKO
Canada	INDUSTRY CANADA , CSA
R.O.C.	CNLA, BSMI, NCC
Netherlands	Telefication
Singapore	PSB , GOST-ASIA(MOU)
Russia	CERTIS(MOU)

Copies of accreditation certificates of our laboratories obtained from approval agencies can be downloaded from our web site:

www.adt.com.tw/index.5/phtml. If you have any comments, please feel free to contact us at the following:

Linko EMC/RF Lab:

Tel: 886-2-26052180

Fax: 886-2-26051924

Hsin Chu EMC/RF Lab:

Tel: 886-3-5935343

Fax: 886-3-5935342

Hwa Ya EMC/RF/Safety Telecom Lab: Linko RF Lab.

Tel: 886-3-3183232

Fax: 886-3-3185050

Tel: 886-3-3270910

Fax: 886-3-3270892

Web Site: www.adt.com.tw

The address and road map of all our labs can be found in our web site also.



APPENDIX-A

MODIFICATIONS RECORDERS FOR ENGINEERING CHANGES TO THE EUT BY THE LAB

No any modifications are made to the EUT by the lab during the test.