



FCC 47 CFR PART 15 SUBPART C AND ANSI C63.4 : 2003

TEST REPORT

For

Wireless N Router

Model : DIR-605

Trade Name : D-Link

Issued for

D-Link Corporation

**No. 289, Sinhu 3rd Rd., Neihu District, Taipei City 114,
Taiwan, R.O.C.**

Issued by

Compliance Certification Services Inc.

Tainan Laboratory

No. 8, Jiu Cheng Ling, Jiaokeng Village, Sinhua
Township, Tainan Hsien 712, Taiwan R.O.C.

TEL: 886-6-580-2201

FAX: 886-6-580-2202



***Note:** This report shall not be reproduced except in full, without the written approval of Compliance Certification Services Inc. This document may be altered or revised by Compliance Certification Services Inc. personnel only, and shall be noted in the revision section of the document. The client should not use it to claim product endorsement by TAF or any government agencies. The test results in the report only apply to the tested sample.*



Revision History

Rev.	Issue Date	Revisions	Effect Page	Revised By
00	08/04/2009	Initial Issue	All Page 140	Jeter Wu



TABLE OF CONTENTS

TITLE	PAGE NO.
1. TEST REPORT CERTIFICATION.....	4
2. EUT DESCRIPTION.....	5
2.1 DESCRIPTION OF EUT & POWER.....	5
3. DESCRIPTION OF TEST MODES.....	6
4. TEST METHODOLOGY.....	6
5. FACILITIES AND ACCREDITATIONS.....	7
5.1 FACILITIES.....	7
5.2 EQUIPMENT.....	7
5.3 LABORATORY ACCREDITATIONS LISTINGS.....	7
5.4 TABLE OF ACCREDITATIONS AND LISTINGS.....	8
6. CALIBRATION AND UNCERTAINTY.....	9
6.1 MEASURING INSTRUMENT CALIBRATION.....	9
6.2 MEASUREMENT UNCERTAINTY.....	9
7. SETUP OF EQUIPMENT UNDER TEST.....	10-11
8. APPLICABLE LIMITS AND TEST RESULTS.....	12
8.1 6dB BANDWIDTH.....	12-25
8.2 99% BANDWIDTH.....	26-39
8.3 MAXIMUM PEAK OUTPUT POWER.....	40-54
8.4 MAXIMUM PERMISSIBLE EXPOSURE.....	55-56
8.5 AVERAGE POWER.....	57-59
8.6 POWER SPECTRAL DENSITY.....	60-79
8.7 CONDUCTED SPURIOUS EMISSION.....	80-96
8.8 RADIATED EMISSIONS.....	97
8.8.1 TRANSMITTER RADIATED SUPURIOUS EMSSIONS.....	97-100
8.8.2 WORST-CASE RADIATED EMISSION BELOW 1 GHz.....	101
8.8.3 TRANSMITTER RADIATED EMISSION ABOVE 1 GHz.....	102-113
8.8.4 RESTRICTED BAND EDGES.....	114-129
8.9 POWERLINE CONDUCTED EMISSIONS.....	130-133
APPENDIX SETUP PHOTOS.....	134-140



1. TEST REPORT CERTIFICATION

Applicant : D-Link Corporation
Address : No. 289, Sinhu 3rd Rd., Neihu District, Taipei City 114,
Taiwan, R.O.C.
Equipment Under Test : Wireless N Router
Model : DIR-605
Trade Name : D-Link
Tested Date : July 03 ~ August 03, 2009

APPLICABLE STANDARD	
STANDARD	TEST RESULT
FCC Part 15 Subpart C AND ANSI C63.4:2003	PASS

Approved by:

Jeter Wu
Section Manager

Reviewed by:

Eric Yang
Senior Engineer

WE HEREBY CERTIFY THAT: The measurements shown in the attachment were made in accordance with the procedures indicated, and the energy emitted by the equipment was found to be within the limits applicable. We assume full responsibility for the accuracy and completeness of these measurements and vouch for the qualifications of all persons taking them.



2. EUT DESCRIPTION

2.1 DESCRIPTION OF EUT & POWER

Product Name	Wireless N Router
Model Number	DIR-605
Frequency Range	IEEE 802.11b/g, 802.11n HT20 : 2412MHz ~ 2462MHz IEEE 802.11n HT40 : 2422MHz ~ 2452MHz
Transmit Power	IEEE 802.11b : 22.21dBm IEEE 802.11g : 22.74dBm IEEE 802.11n HT20 : 23.66dBm IEEE 802.11n HT40 : 21.12dBm
Channel Spacing	IEEE 802.11b/g, 802.11n HT20/HT40 : 5MHz
Channel Number	IEEE 802.11b/g, 802.11n HT20 : 11 Channels IEEE 802.11n HT40 : 7 Channels
Transmit Data Rate	IEEE 802.11b : 11, 5.5, 2, 1 Mbps IEEE 802.11g : 54, 48, 36, 24, 18, 12, 9, 6 Mbps IEEE 802.11n HT20 : 144.444, 130, 117, 115.556, 104, 86.667, 78, 72.222, 65, 58.5, 57.778, 52, 43.333, 39, 28.889, 26, 21.667, 19.5, 14.444, 13, 7.2, 6.5 Mbps IEEE 802.11n HT40 : 300, 270, 243, 240, 216, 180, 162, 150, 135, 121.5, 120, 108, 90, 81, 60, 54, 45, 40.5, 30, 27, 15, 13.5Mbps
Type of Modulation	IEEE 802.11b : DSSS (CCK, DQPSK, DBPSK) IEEE 802.11g : OFDM (64QAM, 16QAM, QPSK, BPSK) IEEE 802.11n HT20/40 : OFDM (64QAM, 16QAM, QPSK, BPSK)
Frequency Selection	by software / firmware
Antenna Type	Dipole Antenna × 2, Antenna Gain 1.8dBi
Power Source	5VDC, 1.2A (From Power Adapter)
I/O Port	WAN port × 1, LAN port × 4, Power port × 1
Note	Broadcom RF Module Model:BCM4716B0KFBG

Power Adapter :

No.	Manufacturer	Model No.	Power Input	Power Output
1	D-Link	AMS1-0501200FU	100-240VAC , 50/60Hz , 0.2A/15VA	5V, 1.2A

Remark:

- The sample selected for test was engineering sample that approximated to production product and was provided by manufacturer.
- This submittal(s) (test report) is intended for FCC ID: KA2DIR605D1 filing to comply with Section 15.207, 15.209 and 15.247 of the FCC Part 15, Subpart C Rules.
- For more details, please refer to the User's manual of the EUT.



3. DESCRIPTION OF TEST MODES

The EUT is an 802.11n MIMO transceiver in Wireless N Router form factor. It has two transmitter chains and two receive chains (2×2 configurations). The 2×2 configuration is implemented with two outside chains (Chain 0 and 1).

IEEE 802.11 b, 802.11g, 802.11n HT20 mode

The EUT had been tested under operating condition.

There are three channels have been tested as following :

Channel	Frequency (MHz)
Low	2412
Middle	2437
High	2462

IEEE 802.11b mode : 1Mbps data rate (worst case) were chosen for full testing.

IEEE 802.11g mode : 54Mbps data rate (worst case) were chosen for full testing.

IEEE 802.11n HT20 mode : 6.5Mbps data rate (worst case) were chosen for full testing.

IEEE 802.11n HT40 mode

The EUT had been tested under operating condition.

There are three channels have been tested as following :

Channel	Frequency (MHz)
Low	2422
Middle	2437
High	2452

IEEE 802.11n HT40 mode : 13.5Mbps data rate (worst case) were chosen for full testing.

4. TEST METHODOLOGY

The tests documented in this report were performed in accordance with ANSI C63.4:2003 and FCC CRF 47 15.207, 15.209 and 15.247.



5. FACILITIES AND ACCREDITATIONS

5.1 FACILITIES

All measurement facilities used to collect the measurement data are located at

No. 8, Jiu Cheng Ling, Jiaokeng Village, Sinhua Township, Tainan Hsien 712, Taiwan R.O.C.

The sites are constructed in conformance with the requirements of ANSI C63.7, ANSI C63.4 : 2003 and CISPR Publication 22.

5.2 EQUIPMENT

Radiated emissions are measured with one or more of the following types of linearly polarized antennas: tuned dipole, biconical, log periodic, bi-log, and/or ridged waveguide, horn. Spectrum analyzers with preselectors and quasi-peak detectors are used to perform radiated measurements.

Conducted emissions are measured with Line Impedance Stabilization Networks and EMI Test Receivers.







Calibrated wideband preamplifiers, coaxial cables, and coaxial attenuators are also used for making measurements.

All receiving equipment conforms to CISPR Publication 16-1, "Radio Interference Measuring Apparatus and Measurement Methods."

5.3 LABORATORY ACCREDITATIONS LISTINGS

The test facilities used to perform radiated and conducted emissions tests are accredited by Taiwan Accreditation Foundation for the specific scope of accreditation under Lab Code: 1109 to perform Electromagnetic Interference tests according to FCC PART 15 AND CISPR 22 requirements. In addition, the test facilities are listed with Industry Canada, Certification and Engineering Bureau, IC 2324H-1 for OATS -6.

5.4 TABLE OF ACCREDITATIONS AND LISTINGS

Country	Agency	Scope of Accreditation	Logo
USA	FCC	3/10 meter Open Area Test Sites to perform FCC Part 15/18 measurements	 TW-1037
Japan	VCCI	3/10 meter Open Area Test Sites to perform conducted/radiated measurements	 C-2882 R-2635
Taiwan	TAF	CISPR 11, FCC METHOD-47 CFR Part 18, EN 55011, EN 60601-1-2, CISPR 22, CNS 13438, EN 55022, EN 55024, AS/NZS CISPR 22 CISPR 14, EN 55014-1, EN 55014-2, CNS 13783-1, CISPR 22, CNS 13439, EN 55013, FCC Method-47 CFR Part 15 Subpart B, IC ICES-003, VCCI V-3 & V-4 FCC Method-47 CFR Part 15 Subpart C and ANSI C63.4, LP 0002 EN / IEC 61000-4-2 / -3 / -4 / -5 / -6 / -8 / -11 EN 61000-3-2, EN 61000-3-3 EN 61000-6-3, EN 61000-6-1, AS/NZS 4251.1, EN 61000-6-4, EN 61000-6-2, AS/NZS 4251.2, EN 61204-3, EN 50130-4, EN 62040-2, EN 50371, EN 50385, AS/NZS 4268, ETSI EN 300 386 ETSI EN 300 328, ETSI EN 301 489-1/-3/-9/-17 ETSI EN 301 893, ETSI EN 300 220-2/-1 ETSI EN 300 440-2/-1 ETSI EN 301 357-2/-1 RSS-310, RSS-210 Issue 7, RSS-Gen Issue 2	 
Taiwan	BSMI	CNS 13438, CNS 13783-1, CNS13439	 SL2-IN-E-0039 SL2-R1/R2-0039 SL2-A1-E-0039
Canada	Industry Canada	RSS210, Issue 7	 IC 2324H-1

* No part of this report may be used to claim or imply product endorsement by TAF or any agency of the US Government.



6. CALIBRATION AND UNCERTAINTY

6.1 MEASURING INSTRUMENT CALIBRATION

The measuring equipment utilized to perform the tests documented in this report has been calibrated in accordance with the manufacturer's recommendations, and is traceable to recognized national standards.

6.2 MEASUREMENT UNCERTAINTY

The following table is for the measurement uncertainty, which is calculated as per the document CISPR 16-4.

PARAMETER	UNCERTAINTY
Radiated Emission, 30 to 1000 MHz	+/- 3.2 dB
Radiated Emission, 1 to 26.5GHz	+/- 3.2 dB
Power Line Conducted Emission	+/- 2.1 dB

This uncertainty represents an expanded uncertainty expressed at approximately the 95% confidence level using a coverage factor of k=2.



7. SETUP OF EQUIPMENT UNDER TEST

SUPPORT EQUIPMENT

No.	Product	Manufacturer	Model No.	Serial No.	FCC ID
1	Notebook PC	DELL	Latitude D610	CN-0C4708-48643-625 -5565	E2K24BNHM
2	Notebook PC	HP	nx6130	CNU543274R	CNTWM3B2200BGA
3	Notebook PC	IBM (LENOVO)	7663-AS6	L3F3864	DoC
4	Ethernet Switch	ASUS	GX1008B	88QSA1003522	DoC

SETUP DIAGRAM FOR TESTS

EUT & peripherals setup diagram is shown in appendix setup photos.

EUT OPERATING CONDITION

RF

1. Set up all computers like the setup diagram.
 2. Software settings
 - (1) Notebook ip set two Group:192.168.0.x , 192.168.1.x
 - (2) Super Terminal: Console(115200bps)→Ctrl+C(Termination)→CFE> boot -raw -z
-addr=0x80001000 -max=0x3a0000 :
 - (3) DOS, enter the vmlinuz file storage directory→ Input> tftp-i 192.168.0.1 PUT
vmlinuz
 - (4) Telnet links to equipment (IP address: 192.168.1.1)→ implementation wl command
files inside of the directive
 - (5) DOS, the wl command to enter the store directory: C:\Program Files\DIR 605
\Binaries→implementation epi_ttcp -tsuHfm -l 1400 -n 8000000 192.168.1.255
- TX Mode:
- ⇒ Tx Data Rate:1Mbps (IEEE 802.11b mode , only chain0 TX)
 - 54Mbps (IEEE 802.11g mode , only chain0 TX)
 - 6.5Mbps (IEEE 802.11n HT20 mode ,chain 0/1 TX)
 - 13.5Mbps (IEEE 802.11n HT40 mode, chain 0/1 TX)



⇒ Power control mode:

Power Set: IEEE 802.11b

Channel Low (2412MHz) = 18.5 (only chain0 TX)

Channel Middle (2437MHz) = 17.5 (only chain0 TX)

Channel High (2462MHz) = 17.5 (only chain0 TX)

Power Set: IEEE 802.11g

Channel Low (2412MHz) = 12 (only chain0 TX)

Channel Middle (2437MHz) = 18 (only chain0 TX)

Channel High (2462MHz) = 12 (only chain0 TX)

Power Set: IEEE 802.11n HT20

Channel Low (2412MHz) TX Power0/1= 11

Channel Middle (2437MHz) TX Power0/1= 15

Channel High (2462MHz) TX Power0/1= 11

Power Set: IEEE 802.11n HT40

Channel Low (2422MHz) TX Power0/1= 10

Channel Middle (2437MHz) TX Power0/1= 13

Channel High (2452MHz) TX Power0/1= 10

3. All of the function are under run.

4. Start test.

For Normal operating :

1. Set up all computers like the setup diagram.
2. All of the function are under run.
3. Notebook PC (1)(2)(3) ping IP address -t to EUT.
4. Notebook PC (1) ping IP address -t to Notebook PC (3).
5. Start test.



8. APPLICABLE LIMITS AND TEST RESULTS

8.1 6dB BANDWIDTH

LIMIT

§ 15.247(a) (2) For direct sequence systems, the minimum 6dB bandwidth shall be at least 500kHz

TEST EQUIPMENT

Name of Equipment	Manufacturer	Model	Serial Number	Calibration Due
SPECTRUM ANALYZER	AGILENT	E4446A	MY43360132	06/09/2010
SPECTRUM ANALYZER	AGILENT	E4446A	MY46180323	05/26/2010

Remark: Each piece of equipment is scheduled for calibration once a year.

TEST SETUP

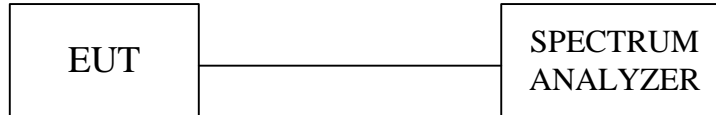

TEST PROCEDURE

The transmitter output was connected to a spectrum analyzer. The bandwidth of the fundamental frequency was measured by spectrum analyzer with 100 KHz RBW and 300 KHz VBW. The 6dB bandwidth is defined as the total spectrum the power of which is higher than peak power minus 6dB.

**TEST RESULTS****IEEE 802.11b mode**

Channel	Channel Frequency (MHz)	6dB Bandwidth (MHz)	Minimum Limit (kHz)	Pass / Fail
Low	2412	6.92	500	PASS
Middle	2437	7.83	500	PASS
High	2462	7.67	500	PASS

IEEE 802.11g mode

Channel	Channel Frequency (MHz)	6dB Bandwidth (MHz)	Minimum Limit (kHz)	Pass / Fail
Low	2412	14.92	500	PASS
Middle	2437	15.92	500	PASS
High	2462	15.08	500	PASS

IEEE 802.11n HT20 mode (Two TX)

Channel	Channel Frequency (MHz)	6dB Bandwidth (MHz)		Minimum Limit (kHz)	Pass / Fail
		Chain 0	Chain 1		
Low	2412	12.33	17.42	500	PASS
Middle	2437	17.00	17.50	500	PASS
High	2462	14.25	16.67	500	PASS

IEEE 802.11n HT40 mode (Two TX)

Channel	Channel Frequency (MHz)	6dB Bandwidth (MHz)		Minimum Limit (kHz)	Pass / Fail
		Chain 0	Chain 1		
Low	2422	36.33	36.00	500	PASS
Middle	2437	32.67	28.75	500	PASS
High	2452	28.58	34.50	500	PASS



6dB BANDWIDTH (IEEE 802.11b mode)

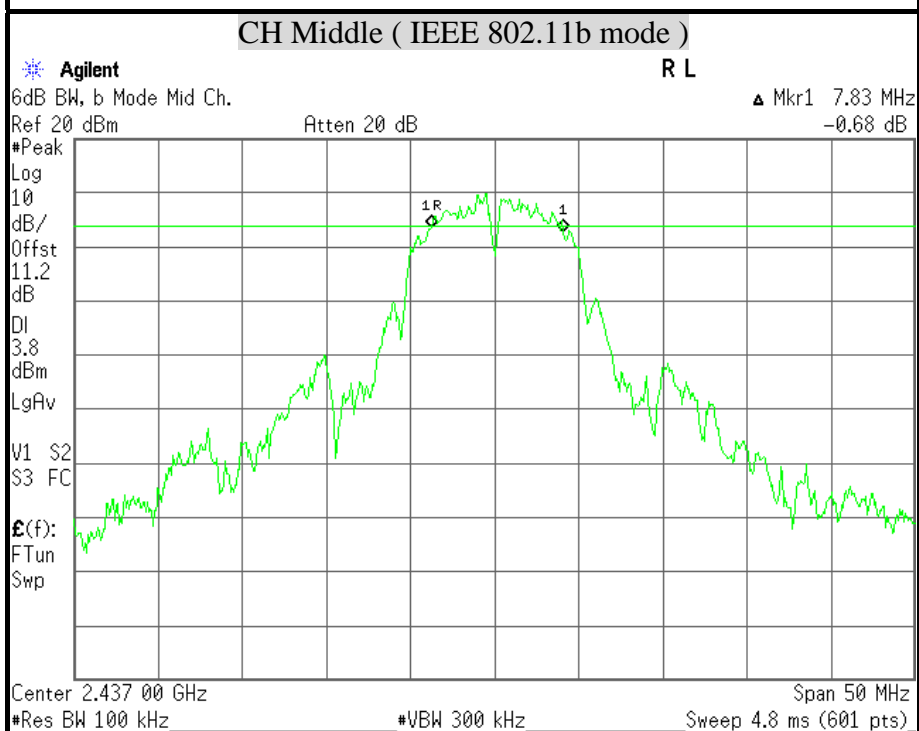
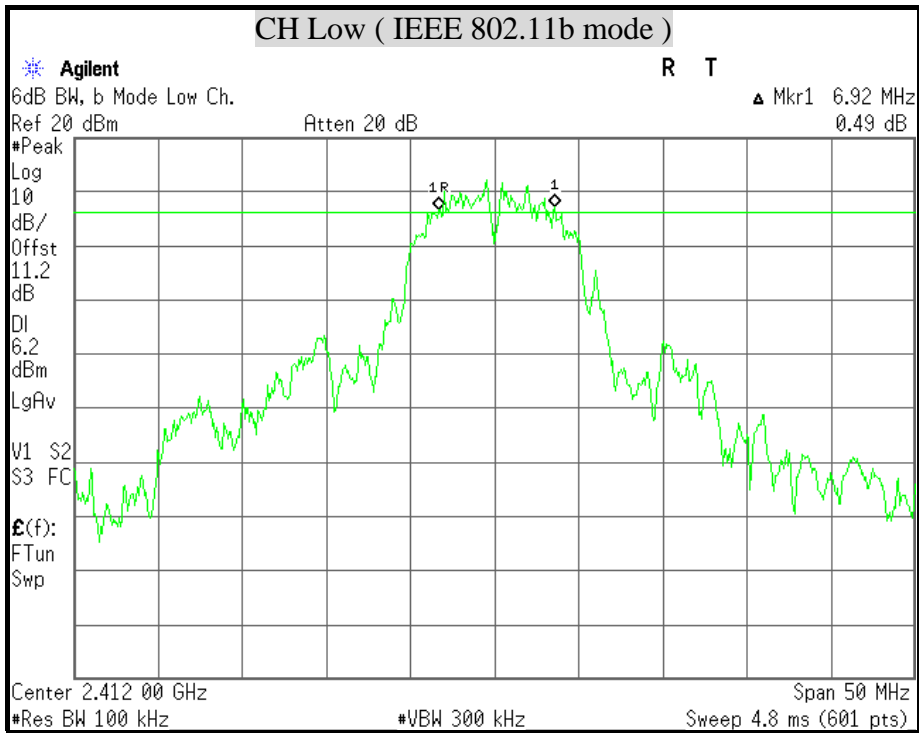

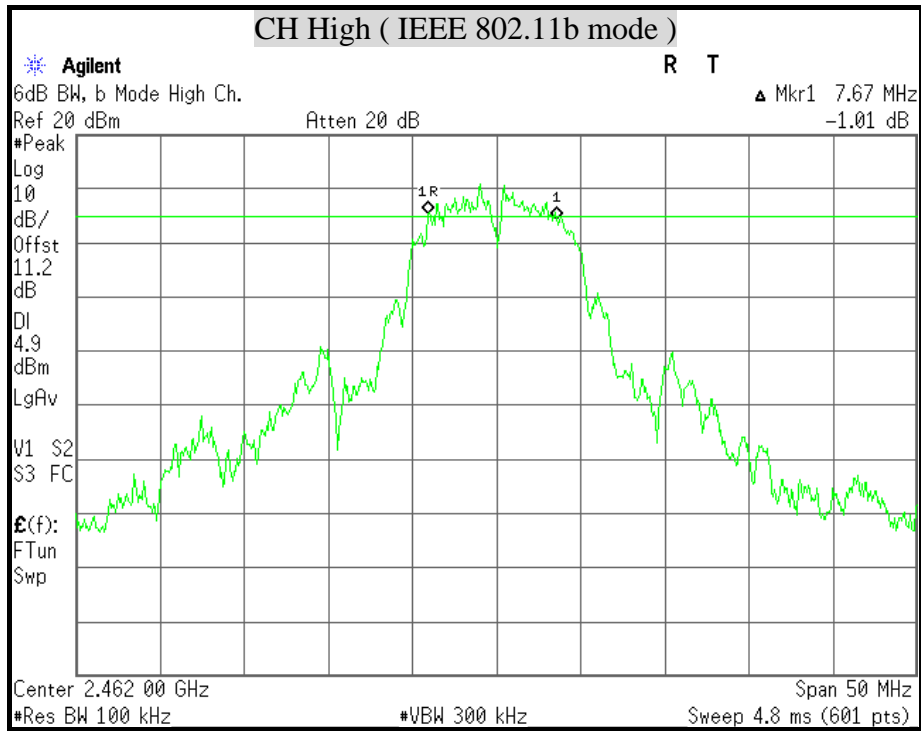



6dB BANDWIDTH (IEEE 802.11g mode)

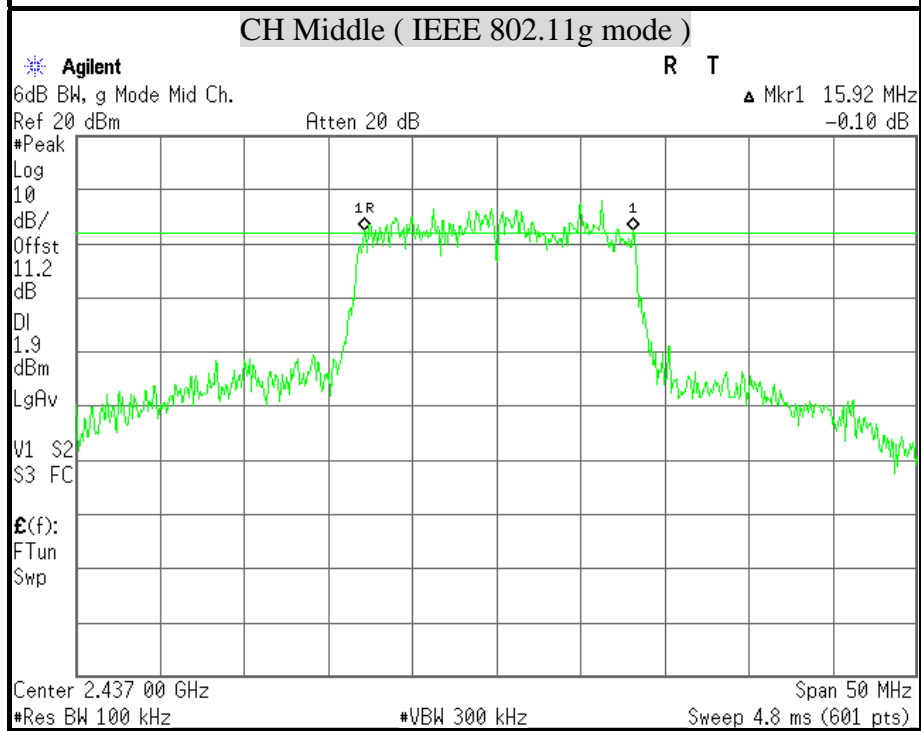
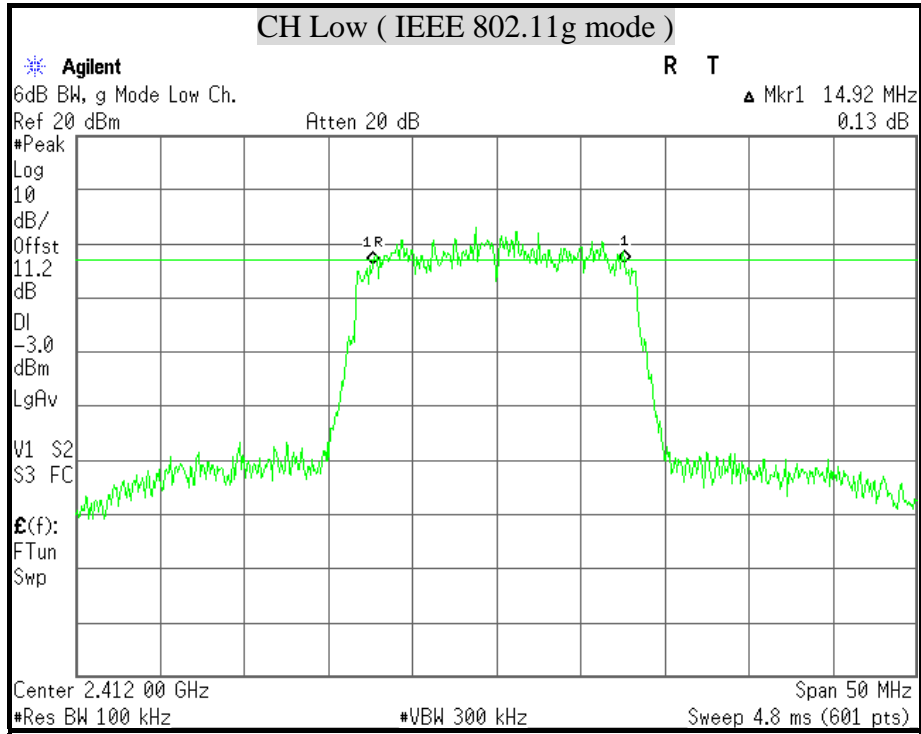

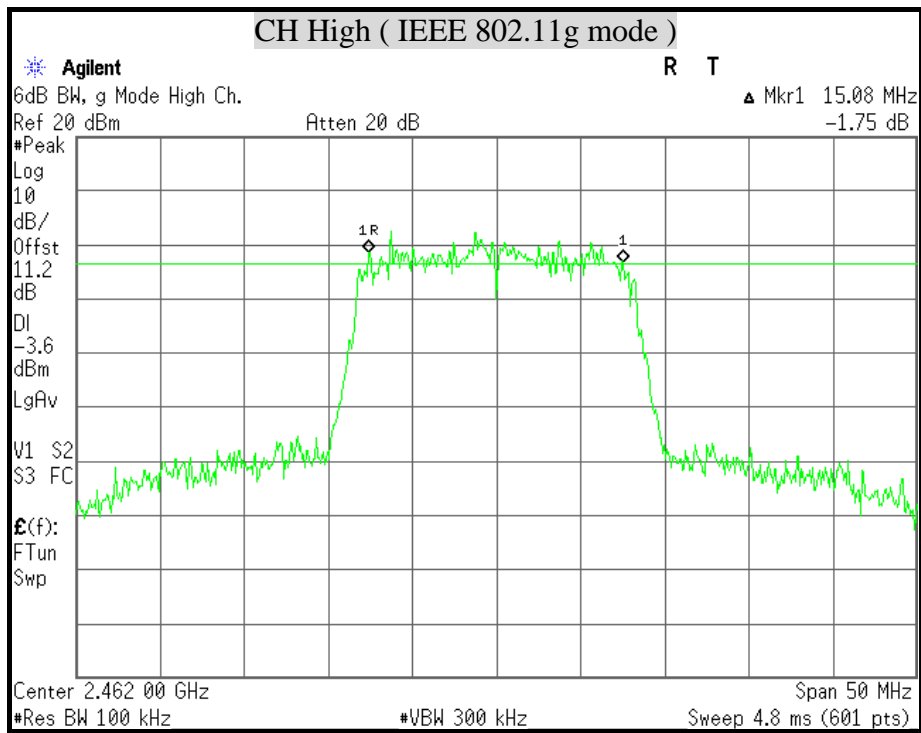



6dB BANDWIDTH (IEEE 802.11n HT20 mode)

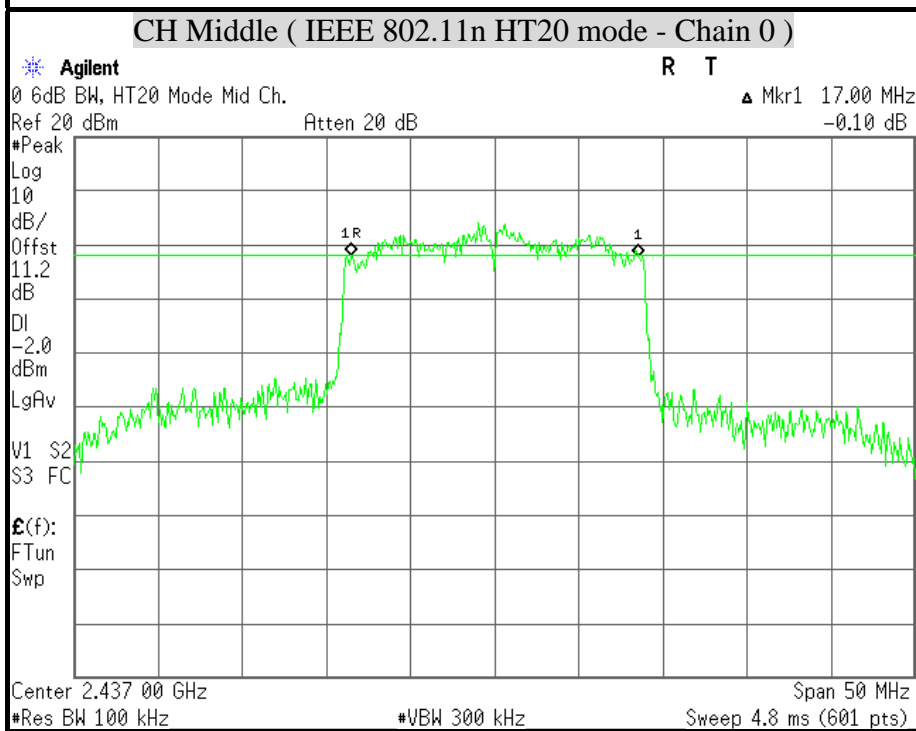
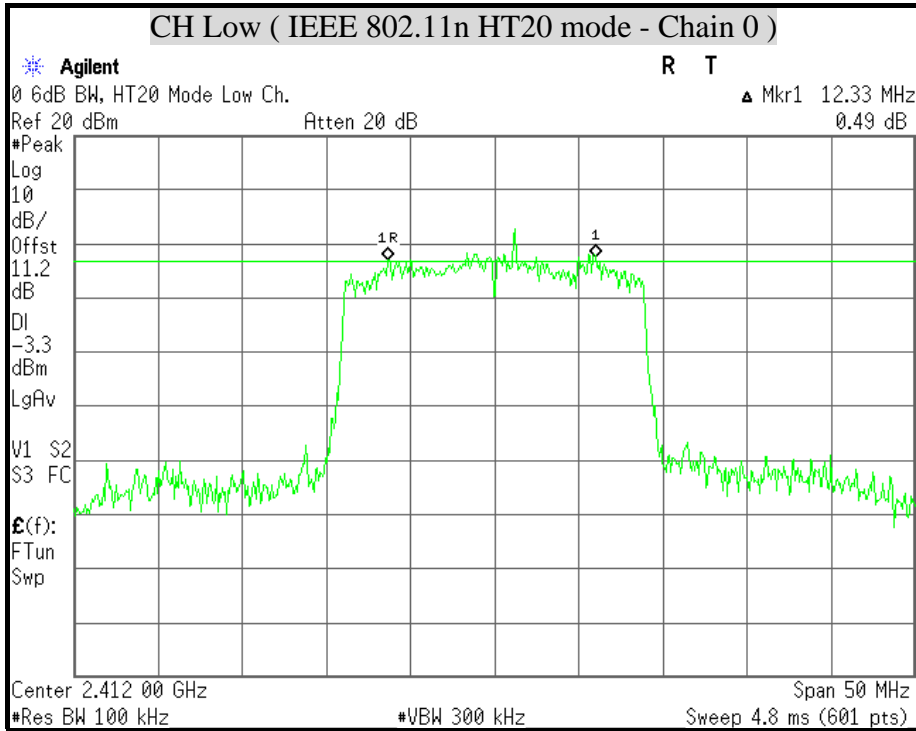

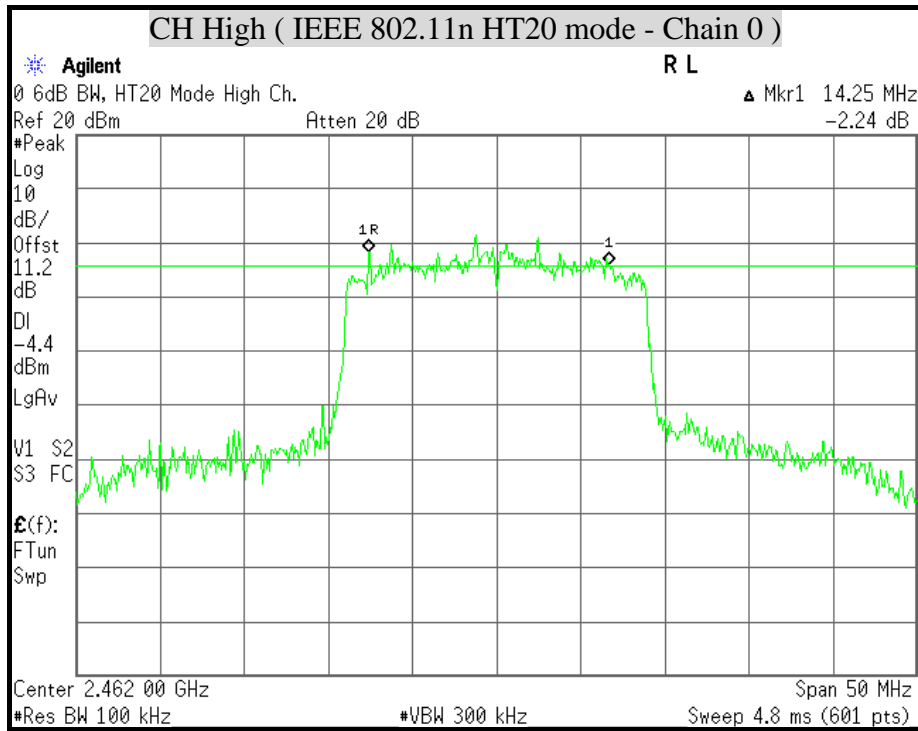

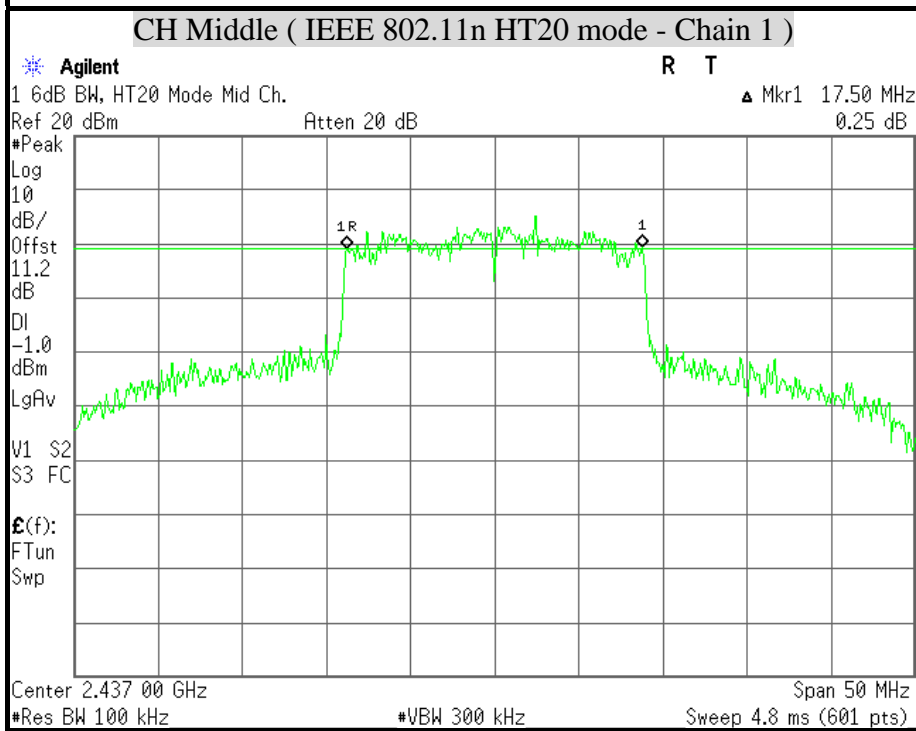
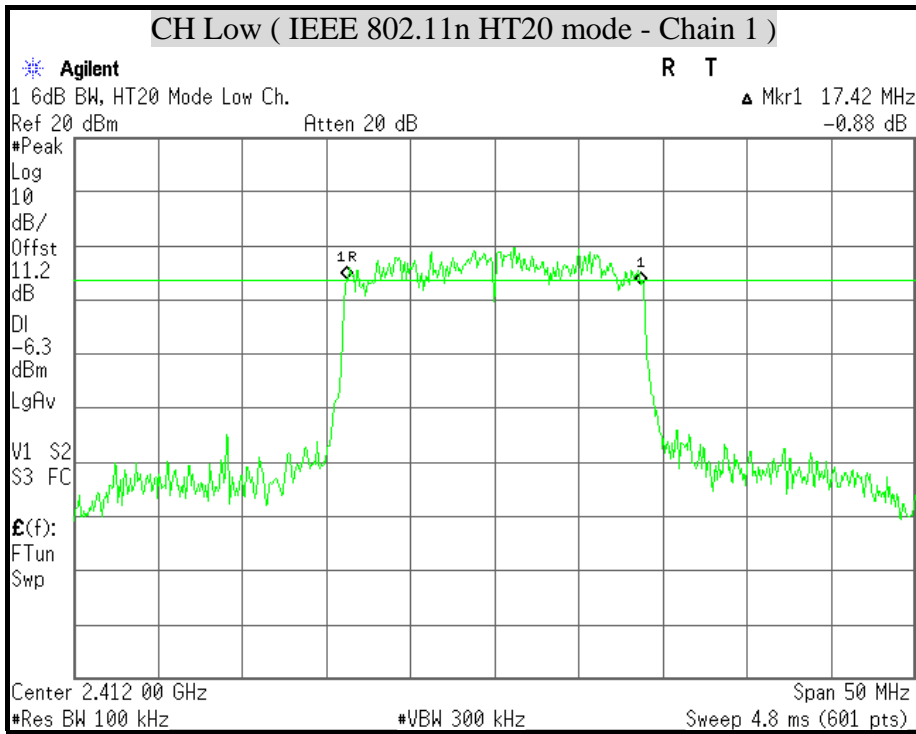

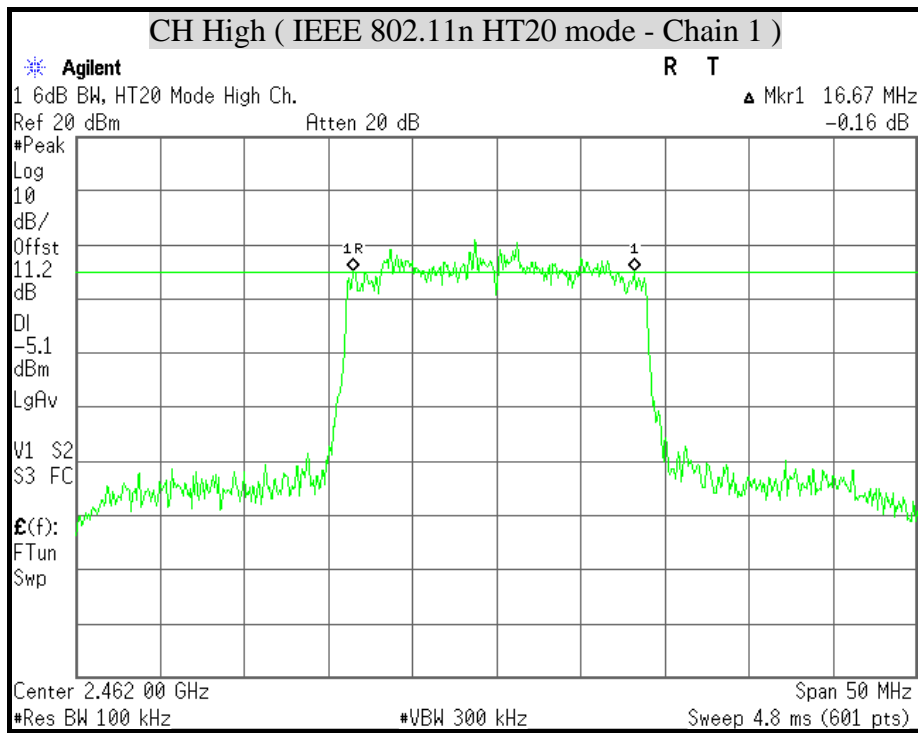



6dB BANDWIDTH (IEEE 802.11n HT40 mode)

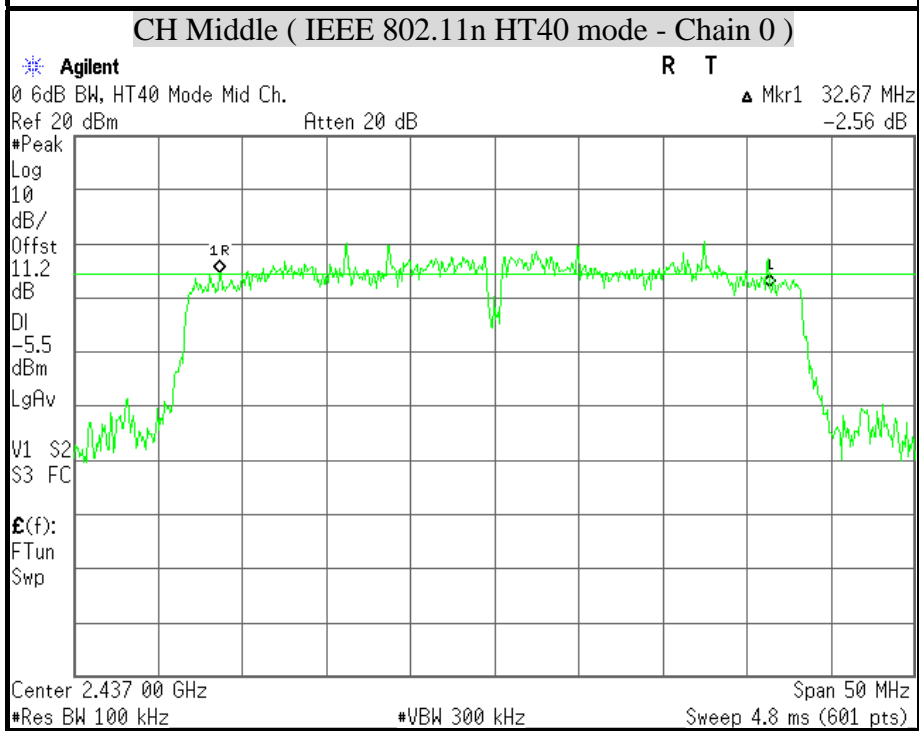
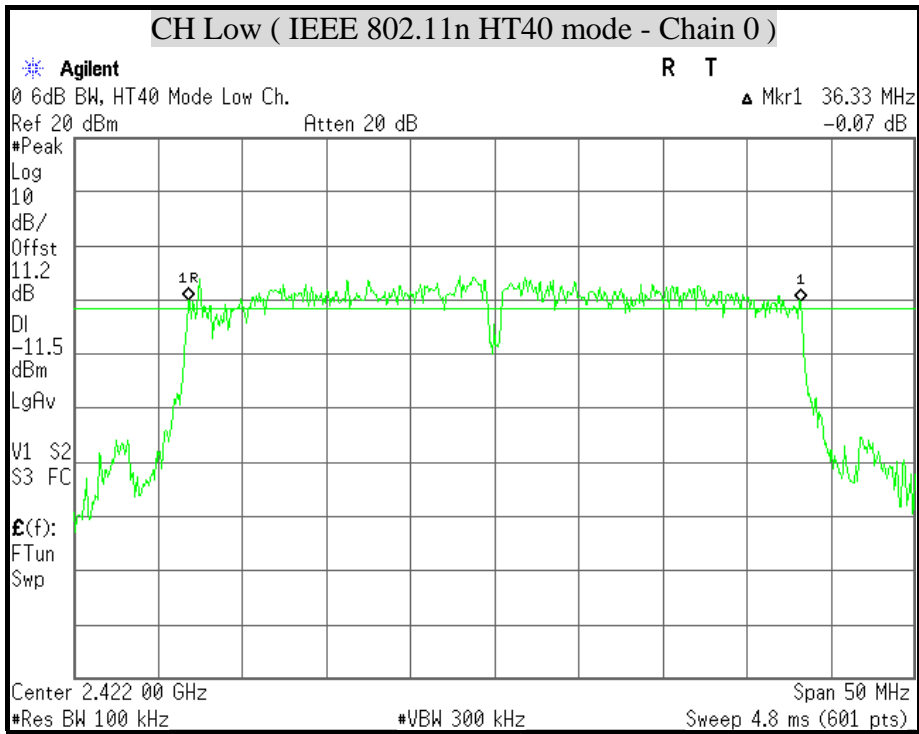

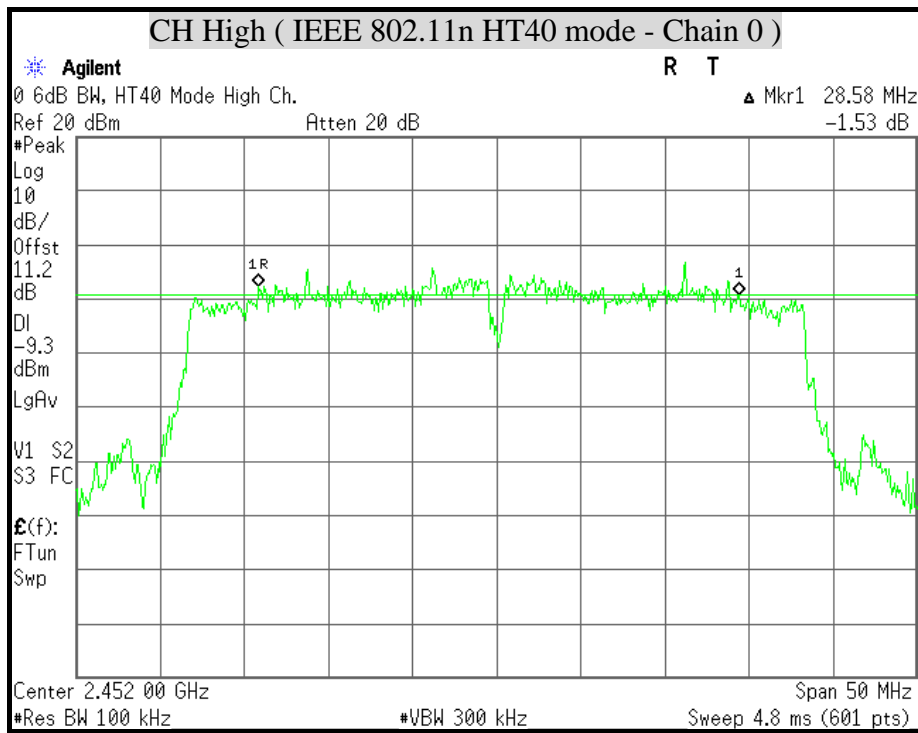

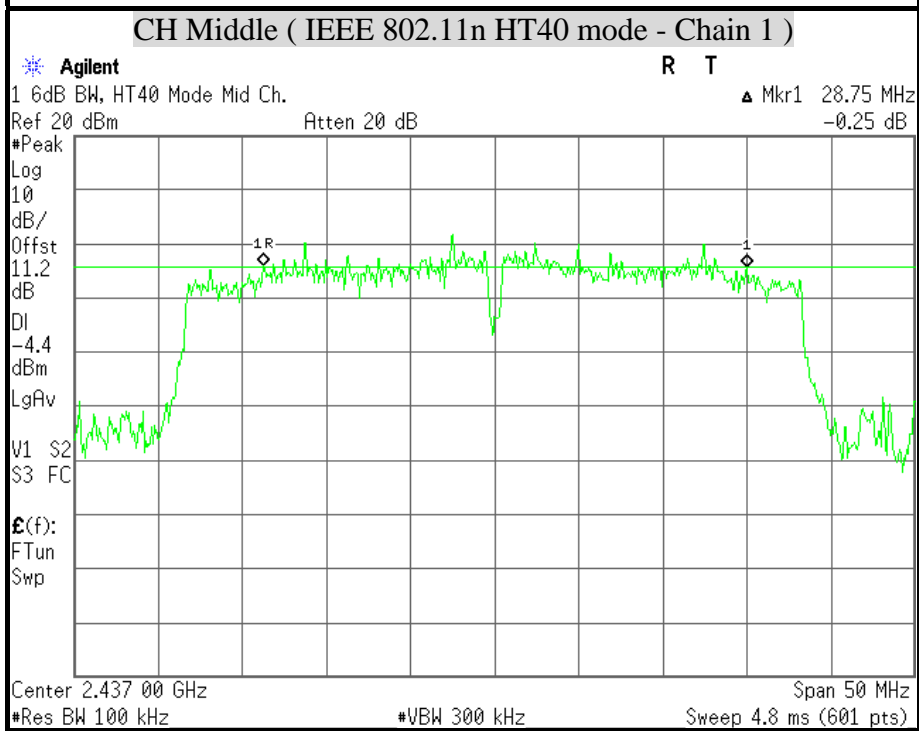
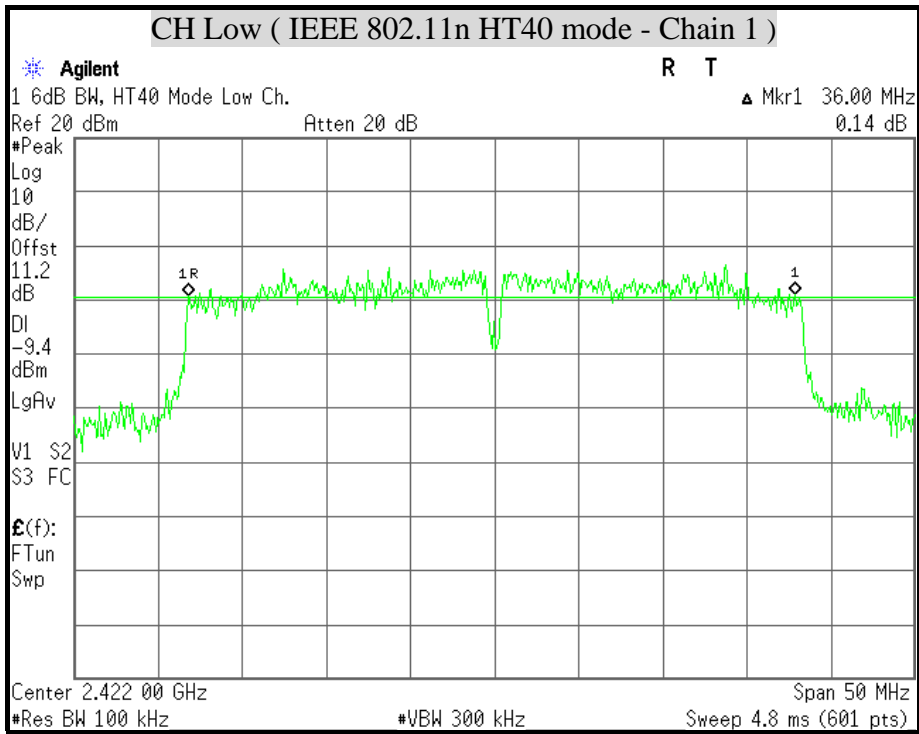

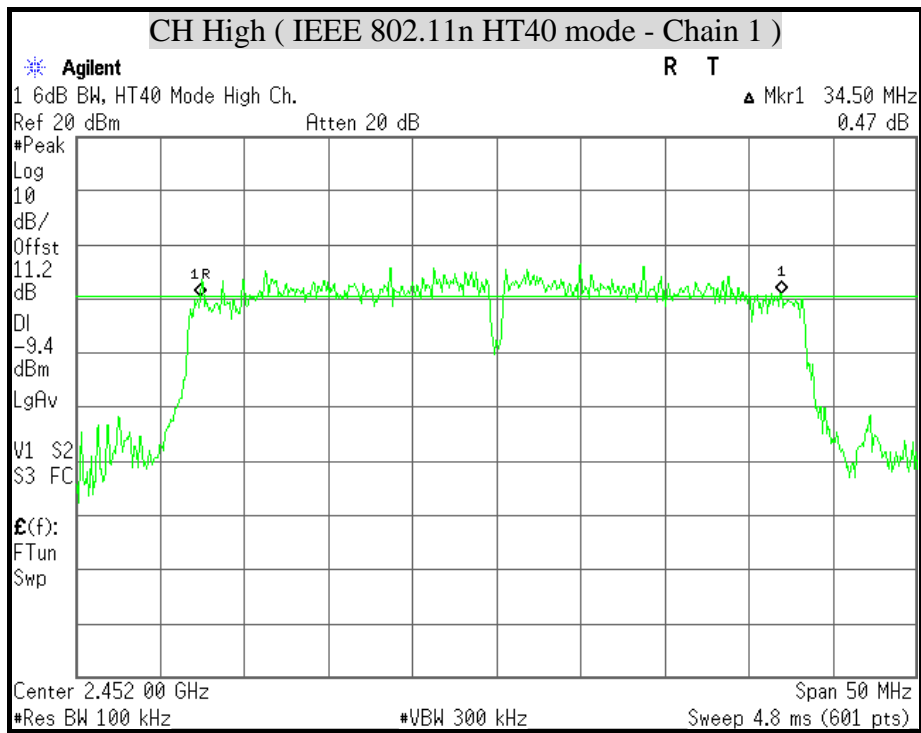



8.2 99% BANDWIDTH

LIMIT

None; for reporting purposes only.

TEST EQUIPMENT

Name of Equipment	Manufacturer	Model	Serial Number	Calibration Due
SPECTRUM ANALYZER	AGILENT	E4446A	MY43360132	06/09/2010
SPECTRUM ANALYZER	AGILENT	E4446A	MY46180323	05/26/2010

Remark: Each piece of equipment is scheduled for calibration once a year.

TEST SETUP



TEST PROCEDURE

1. The spectrum shall be set as follows :

Span : The minimum span to fully display the emission and approximately 20dB below peak level.

RBW : The set to 1% to 3% of the approximate emission width.

2. Compute the combined power of all signal responses contained in the trace by covering all the data points.

3. For 99% occupied BW, place the markers at the frequency at which 0.5% of the power lies to the right of the right marker and 0.5% of the power lies to the left of the left marker.

4. The 99% BW is the bandwidth between the right and left markers.

**TEST RESULTS****IEEE 802.11b mode**

Channel	Channel Frequency (MHz)	99% Occupied power bandwidth (MHz)
Low	2412	10.083
Middle	2437	10.026
High	2462	10.030

IEEE 802.11g mode

Channel	Channel Frequency (MHz)	99% Occupied power bandwidth (MHz)
Low	2412	16.335
Middle	2437	16.257
High	2462	16.303

IEEE 802.11n HT20 mode (Two TX)

Channel	Channel Frequency (MHz)	99% Occupied power bandwidth (MHz)	
		Chain 0	Chain 1
Low	2412	17.406	17.529
Middle	2437	17.507	17.606
High	2462	17.504	17.529

IEEE 802.11n HT40 mode (Two TX)

Channel	Channel Frequency (MHz)	99% Occupied power bandwidth (MHz)	
		Chain 0	Chain 1
Low	2422	35.823	35.943
Middle	2437	35.935	35.875
High	2452	35.864	35.906



99% BANDWIDTH (IEEE 802.11b mode)

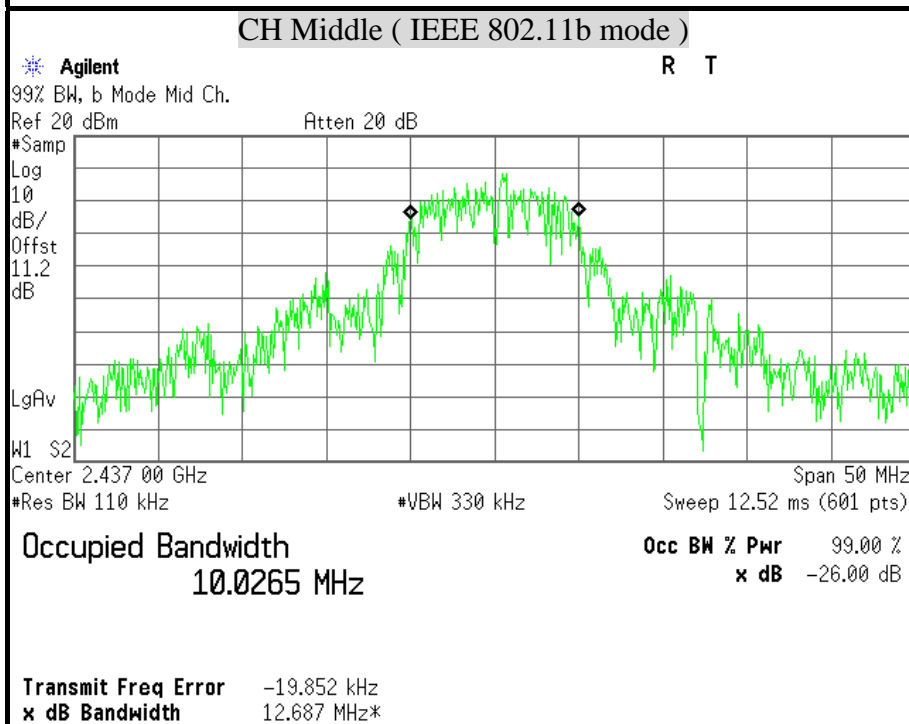
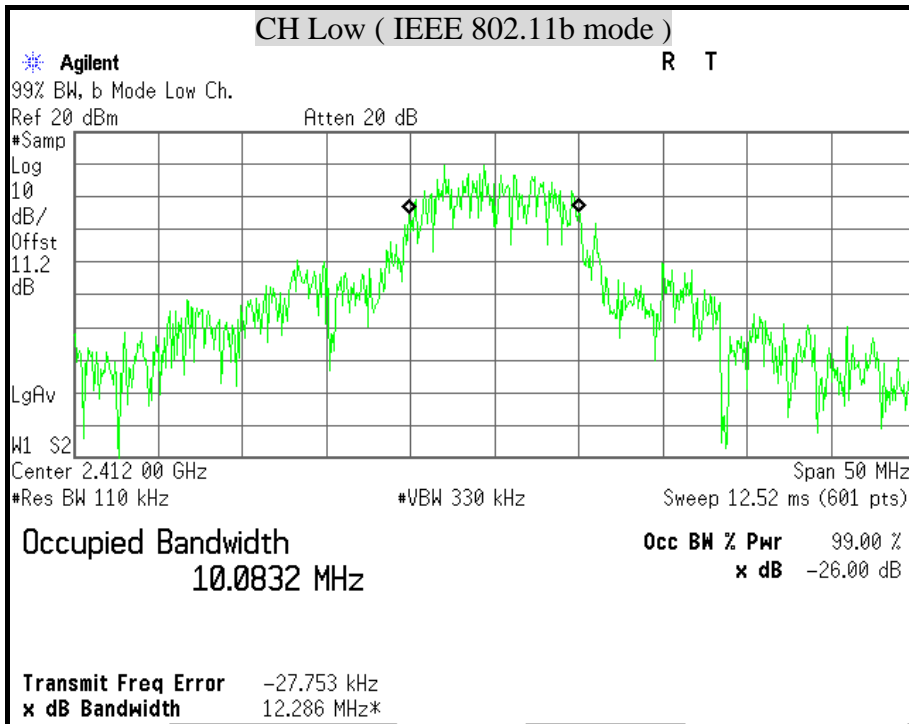

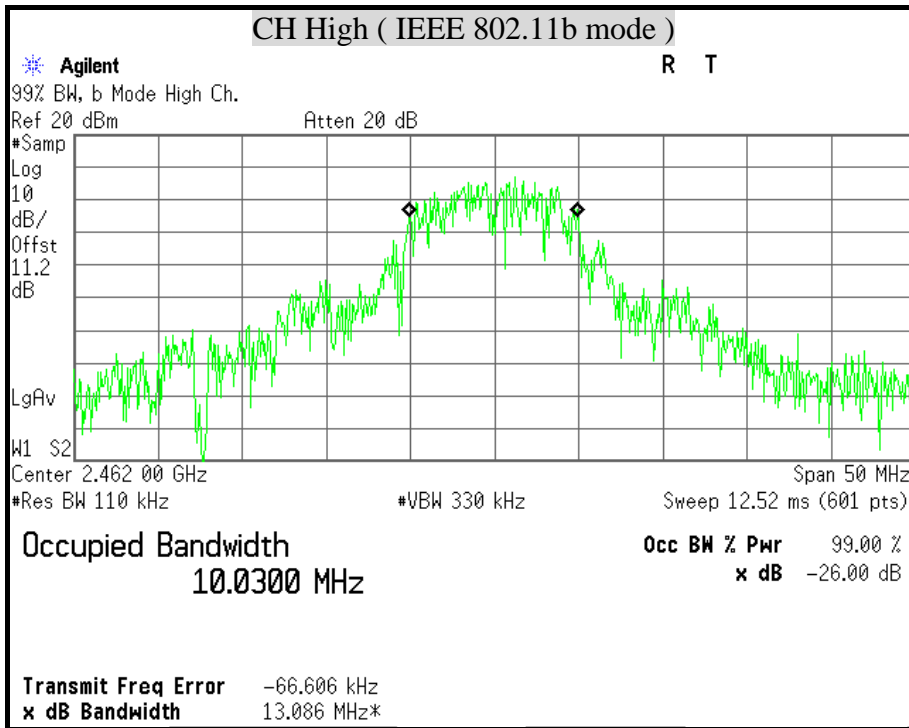



99% BANDWIDTH (IEEE 802.11g mode)

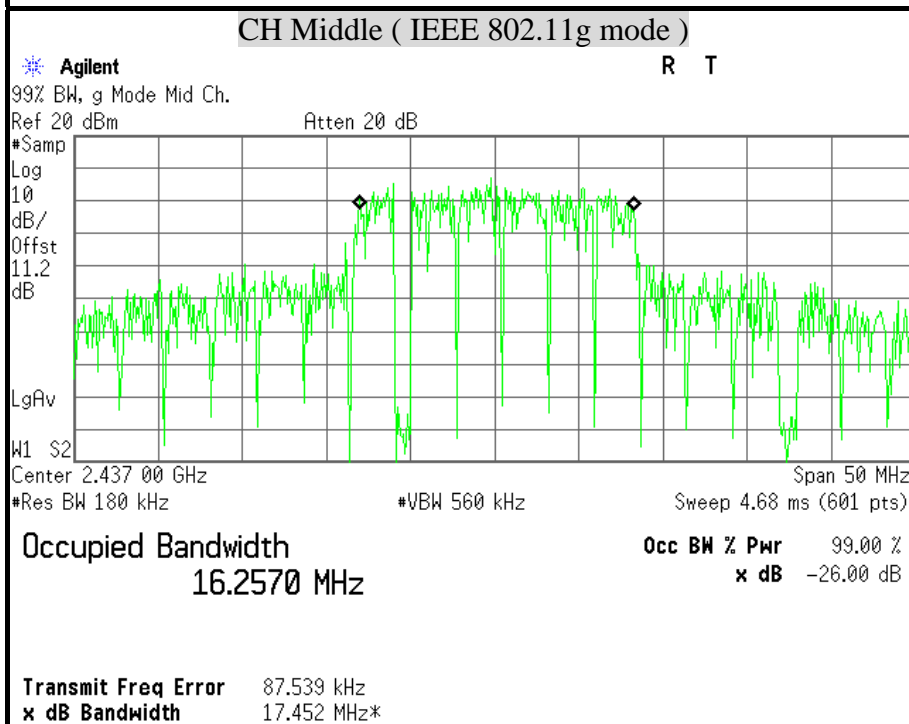
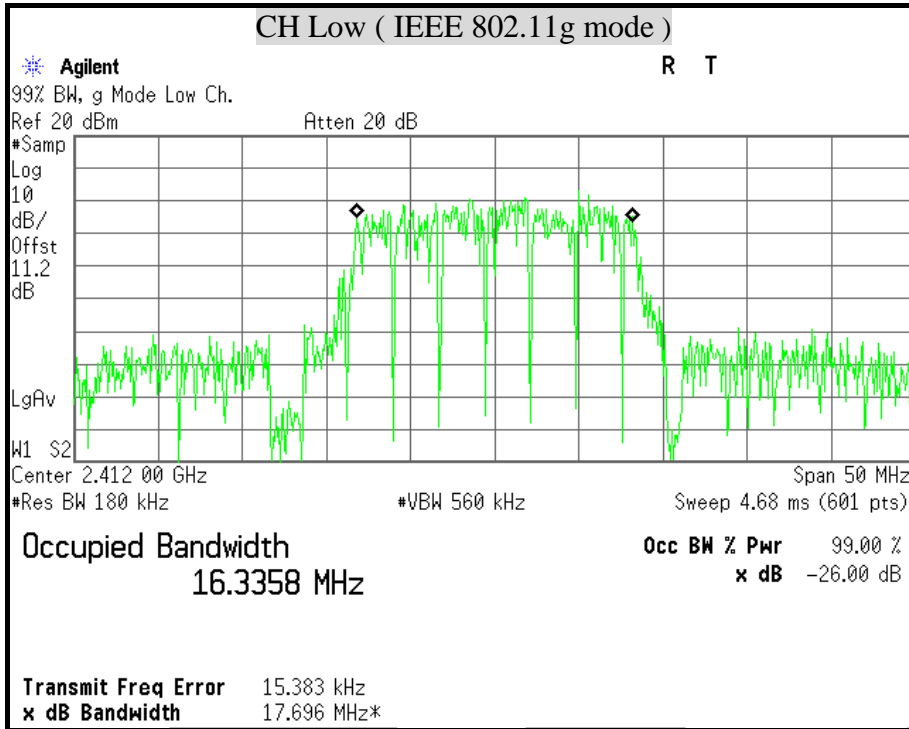

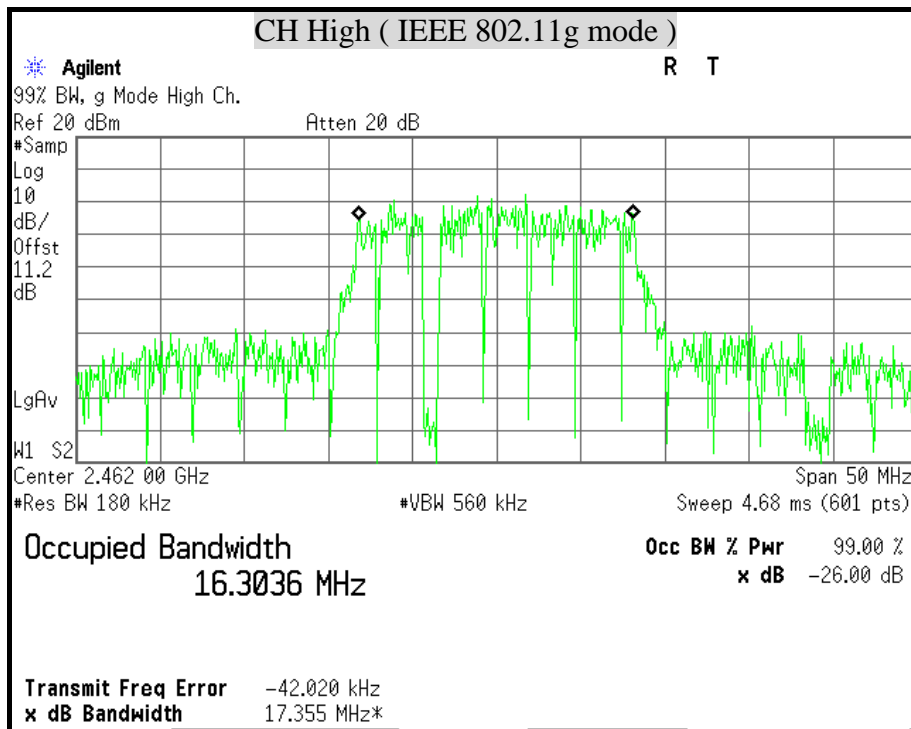



99% BANDWIDTH (IEEE 802.11n HT20 mode)

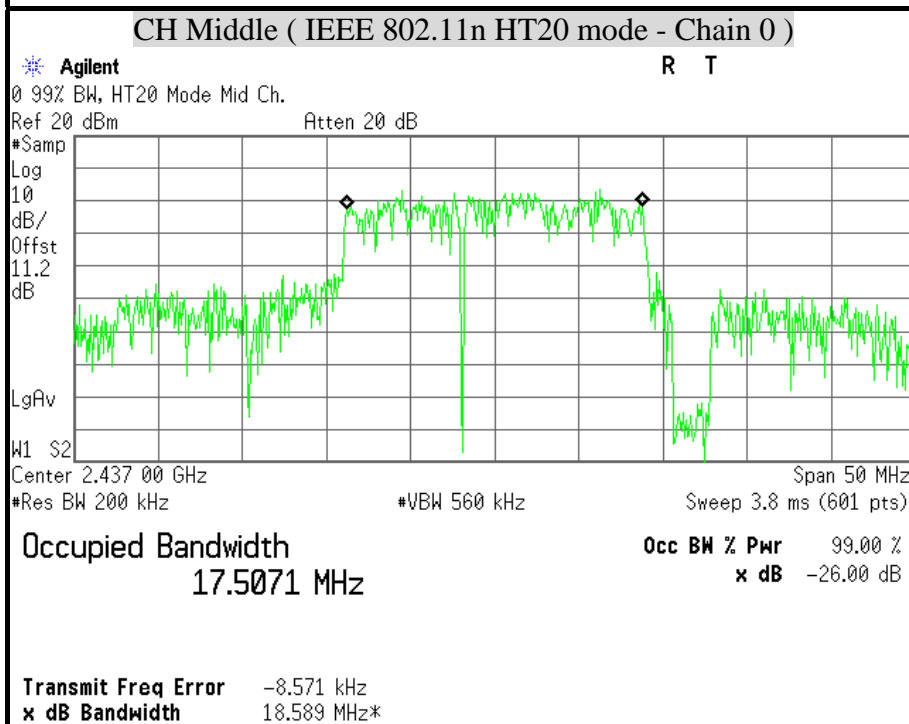
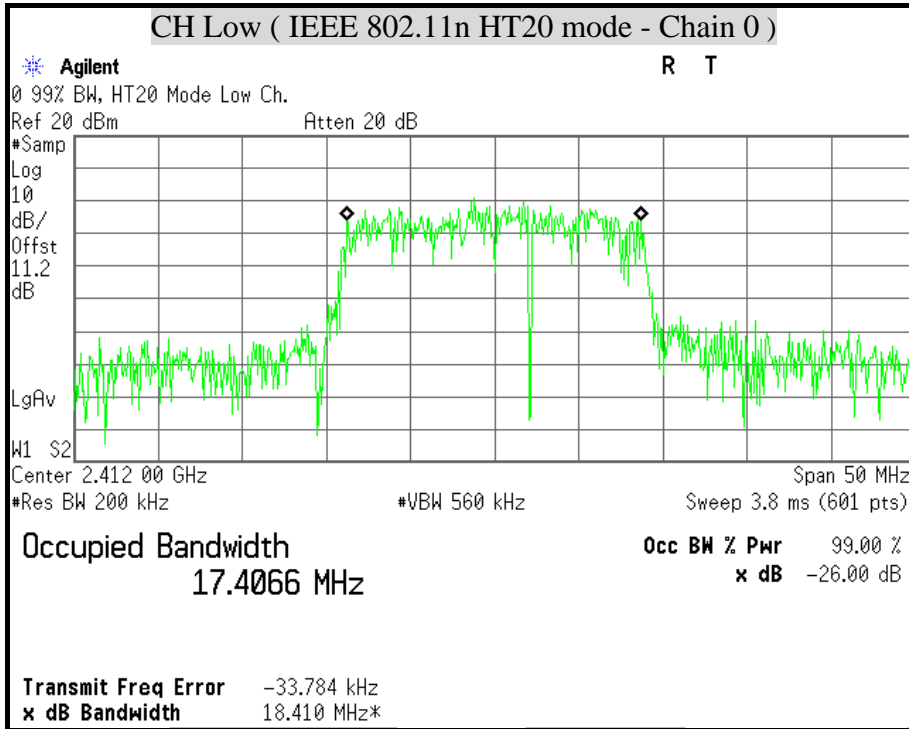

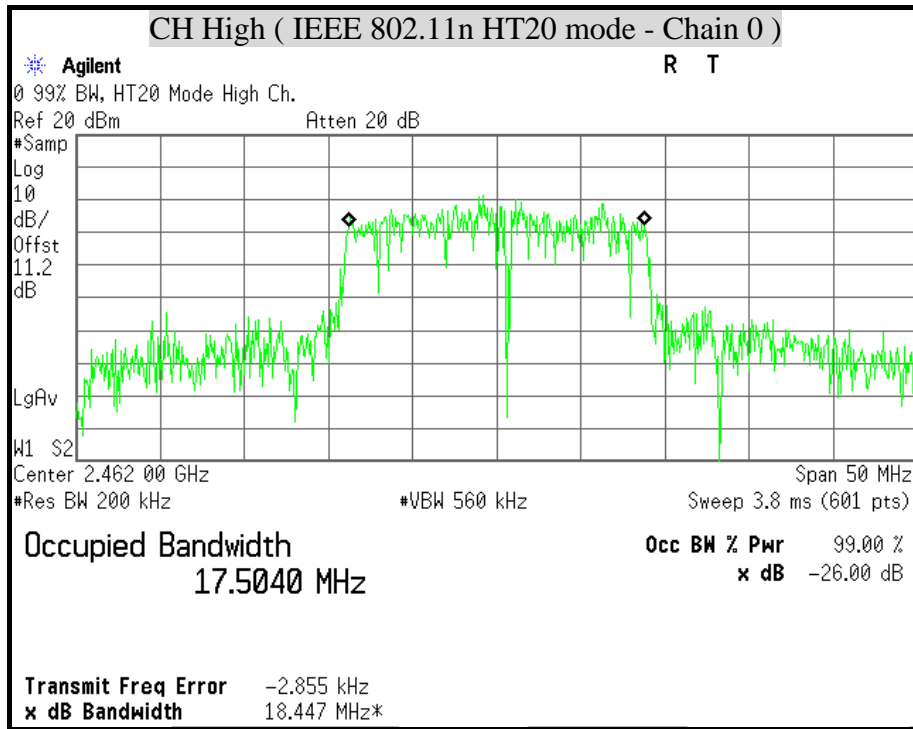

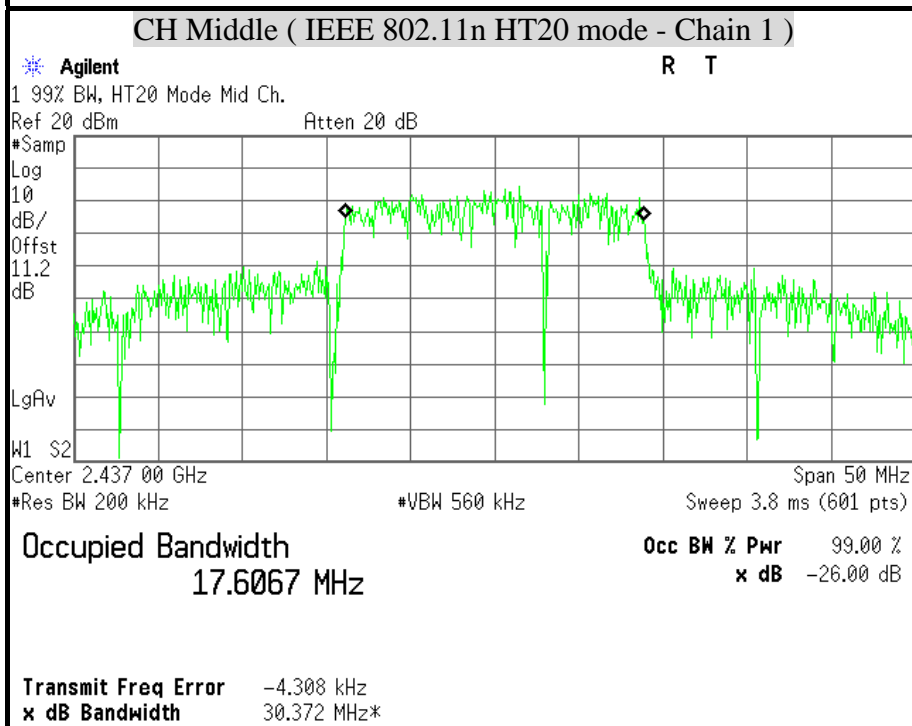
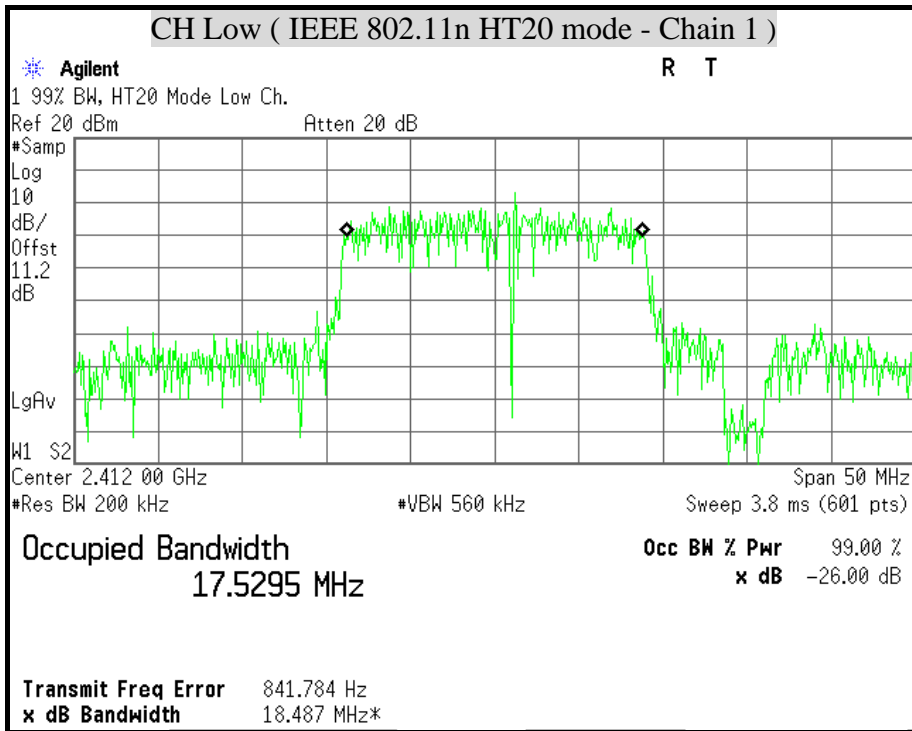

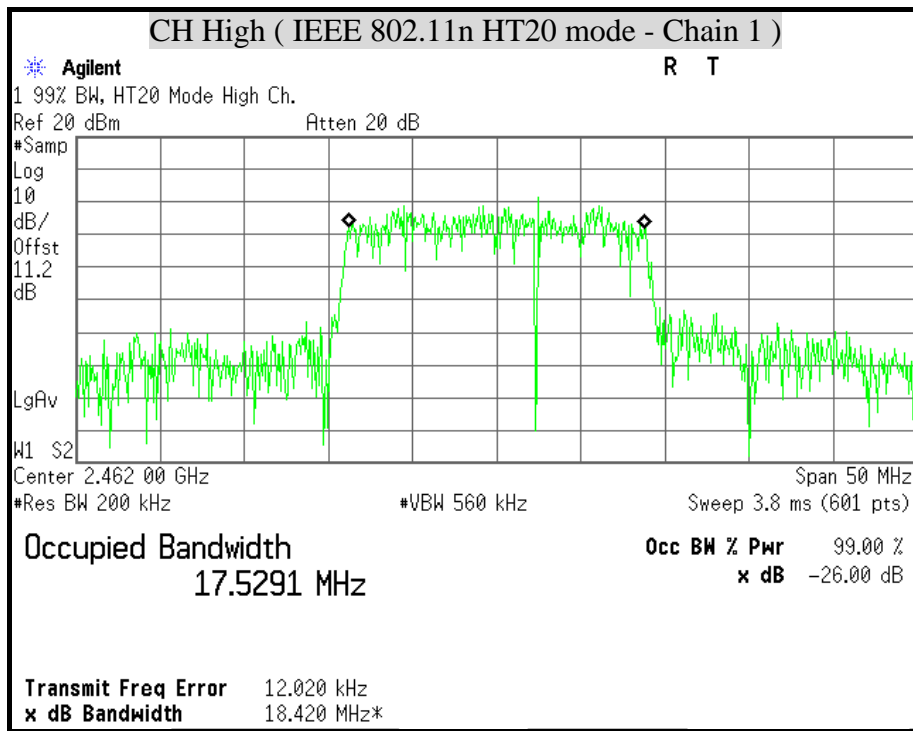



99% BANDWIDTH (IEEE 802.11n HT40 mode)

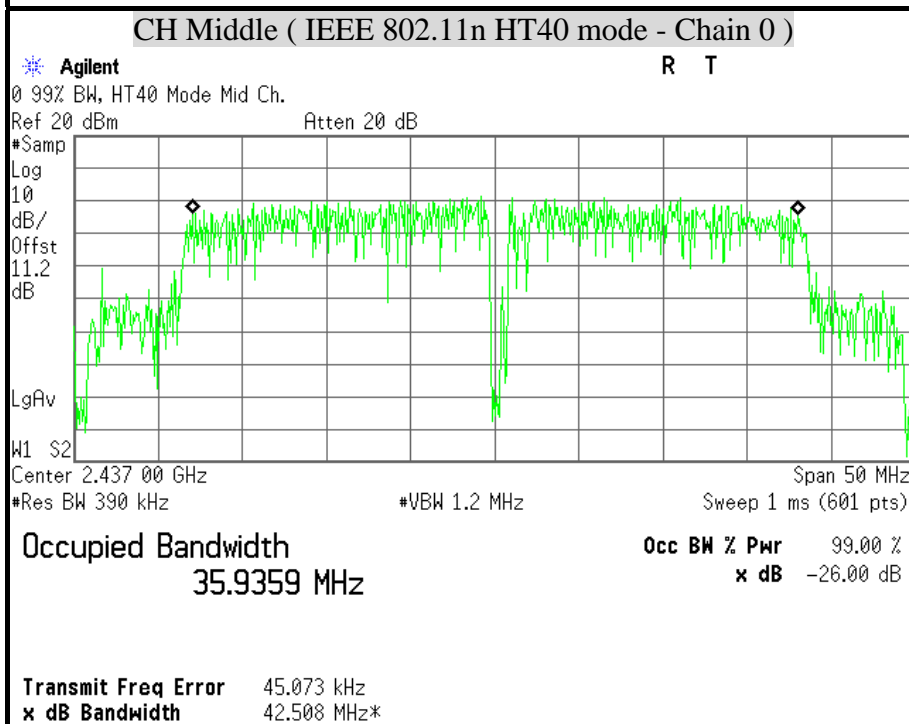
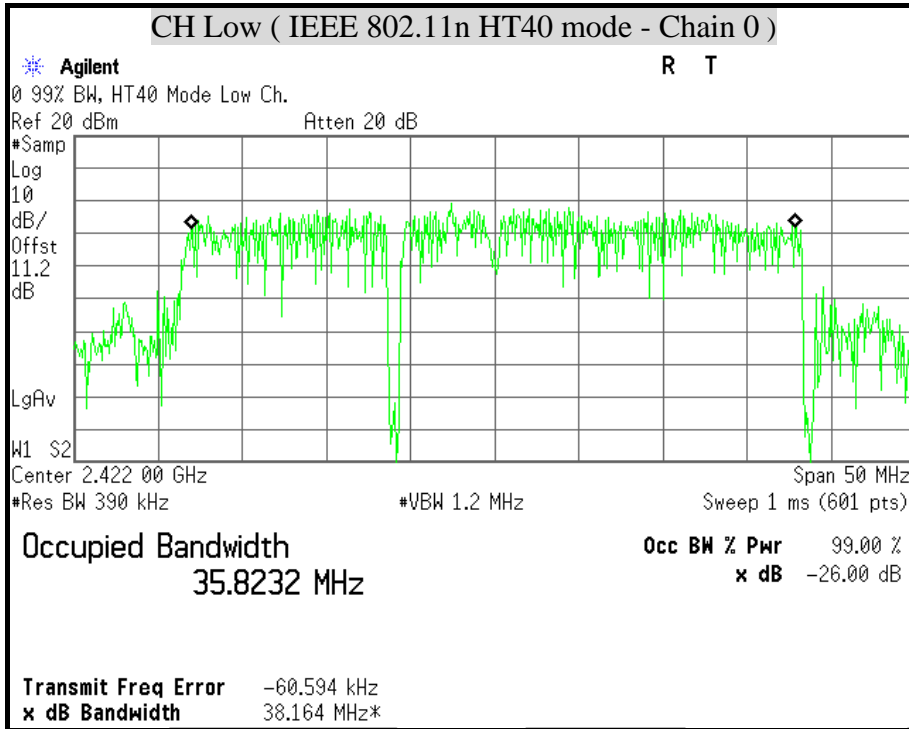

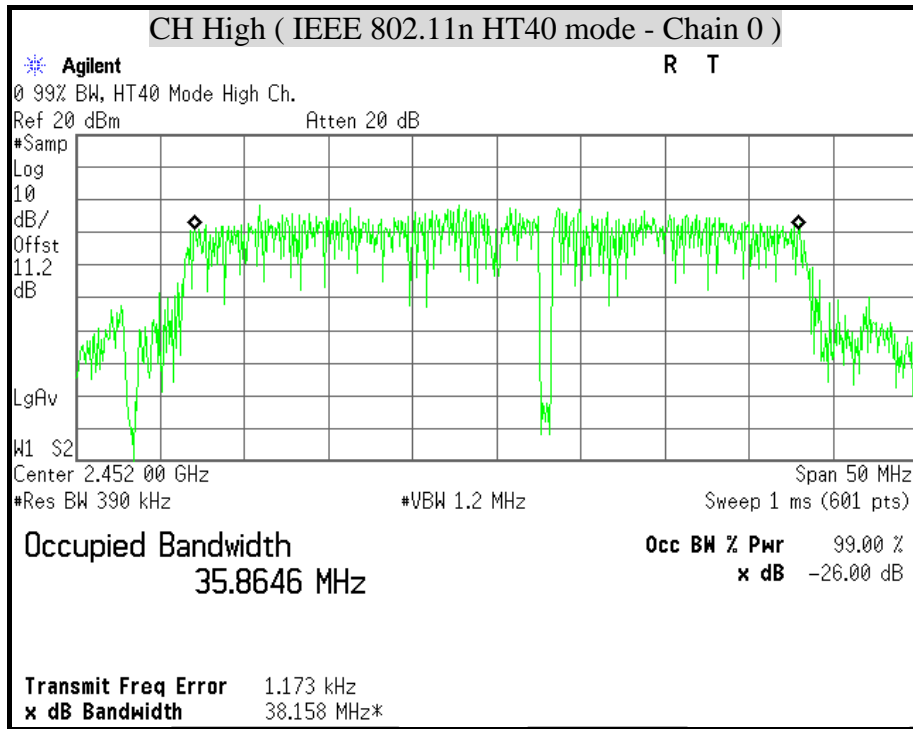

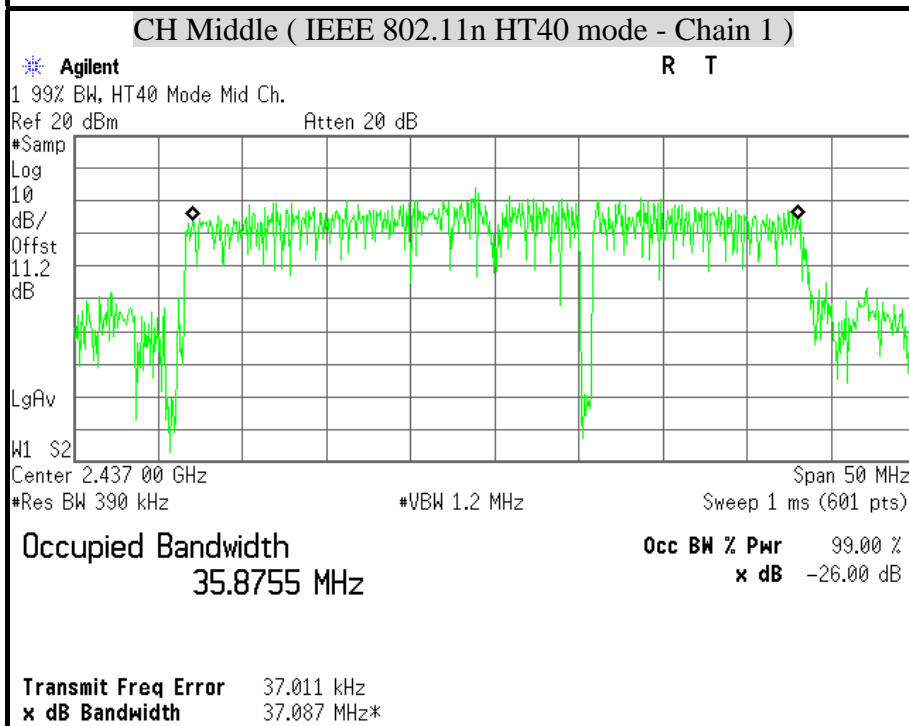
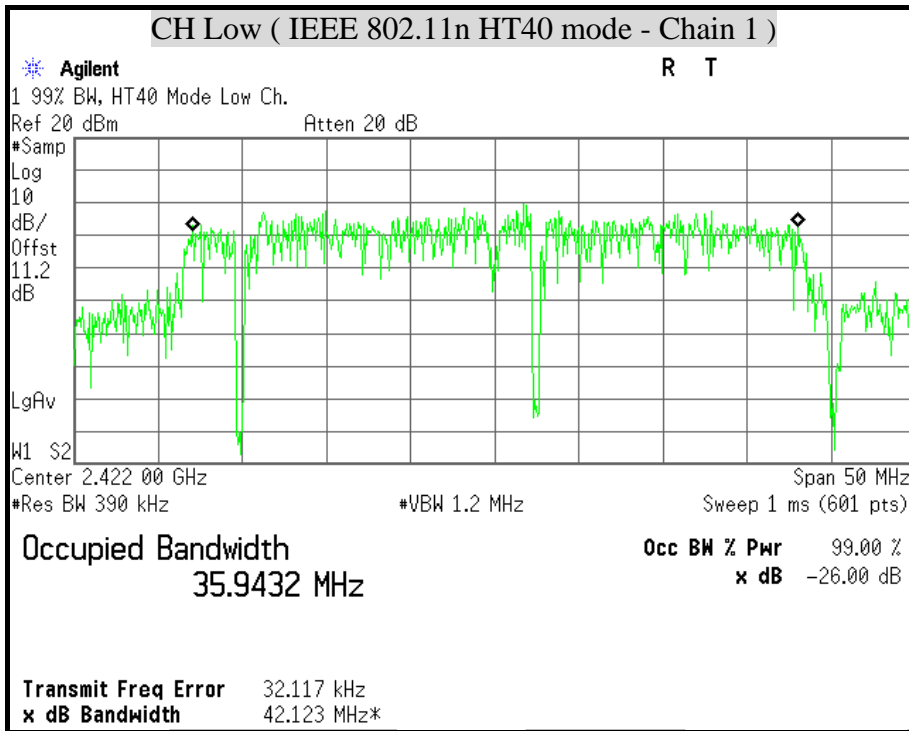

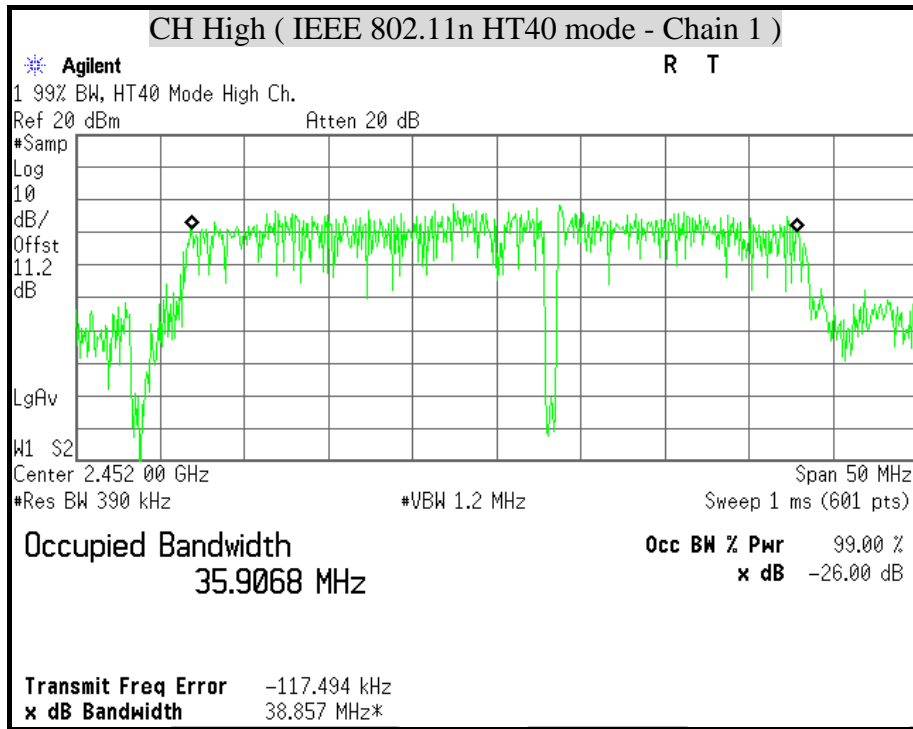



8.3 MAXIMUM PEAK OUTPUT POWER

LIMIT

§ 15.247(b) The maximum peak output power of the intentional radiator shall not exceed the following :

§ 15.247(b) (3) For systems using digital modulation in the 902-928 MHz, 2400-2483.5 MHz, and 5725-5850 MHz bands : 1 watt.

§ 15.247(b) (4) Except as shown in paragraphs (c) of this section , if transmitting antennas of directional gain greater than 6 dBi are used the peak output power from the intentional radiator shall be reduced below the stated values in paragraphs (b)(1) or (b)(2), and (b)(3) of this section , as appropriate, by the amount in dB that the directional gain of the antenna exceeds 6 dBi.

TEST EQUIPMENT

Name of Equipment	Manufacturer	Model	Serial Number	Calibration Due
SPECTRUM ANALYZER	AGILENT	E4446A	MY43360132	06/09/2010
SPECTRUM ANALYZER	AGILENT	E4446A	MY46180323	05/26/2010

Remark: Each piece of equipment is scheduled for calibration once a year.

TEST SETUP

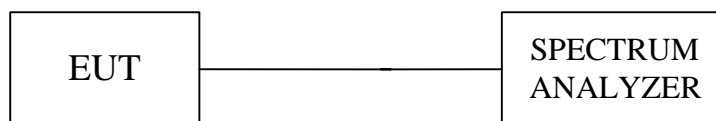

TEST PROCEDURE

- The spectrum shall be set as follows :
Span : 1.5 times channel integration bandwidth.
RBW : 1MHz
VBW : 3MHz
Detector : Peak
Sweep : Single trace
- Compute the combined power of all signal responses contained in the trace by covering all the data points.
- For 99% occupied BW, place the markers at the frequency at which 0.5% of the power lies to the right of the right marker and 0.5% of the power lies to the left of the left marker.
- The peak output power is the channel power integrated over 99% bandwidth.

**TEST RESULTS**

Total peak power calculation formula:

$$10 \log (10^{\text{Chain 0 Power} / 10} + 10^{\text{Chain1 Power} / 10}).$$

The maximum antenna gain is 1.8 dBi, therefore the limit is 30 dBm.

In the legacy mode, the effective antenna gain is $1.8 + 10 \times \text{Log}(2) = 4.81$ dBi.

IEEE 802.11b mode

Channel	Channel Frequency (MHz)	Peak Power (dBm)	Peak Power Limit (dBm)	Pass / Fail
Low	2412	22.21	30	PASS
Middle	2437	21.28	30	PASS
High	2462	21.12	30	PASS

Remark:

1. At final test to get the worst-case emission at 1Mbps.
2. The cable assembly insertion loss of 11.2dB (including 10 dB pad and 1.2 dB cable) was Entered as an offset in the spectrum analyzer to allow for direct reading of power.

IEEE 802.11g mode

Channel	Channel Frequency (MHz)	Peak Power (dBm)	Peak Power Limit (dBm)	Pass / Fail
Low	2412	17.39	30	PASS
Middle	2437	22.74	30	PASS
High	2462	17.66	30	PASS

Remark:

1. At final test to get the worst-case emission at 54Mbps.
2. The cable assembly insertion loss of 11.2dB (including 10 dB pad and 1.2 dB cable) was Entered as an offset in the spectrum analyzer to allow for direct reading of power.

**IEEE 802.11n HT20 mode (Two TX)**

Channel	Channel Frequency (MHz)	Peak Power (dBm)		Peak Power Total (dBm)	Peak Power Limit (dBm)	Pass / Fail
		Chain 0	Chain 1			
Low	2412	16.33	17.34	19.78	30.00	PASS
Middle	2437	20.52	20.78	23.66	30.00	PASS
High	2462	16.26	16.58	19.43	30.00	PASS

Remark:

1. At final test to get the worst-case emission at 6.5Mbps.
2. The cable assembly insertion loss of 11.2dB (including 10 dB pad and 1.2 dB cable) was Entered as an offset in the spectrum analyzer to allow for direct reading of power.

IEEE 802.11n HT40 mode (Two TX)

Channel	Channel Frequency (MHz)	Peak Power (dBm)		Peak Power Total (dBm)	Peak Power Limit (dBm)	Pass / Fail
		Chain 0	Chain 1			
Low	2422	14.41	14.88	17.66	30.00	PASS
Middle	2437	18.27	17.96	21.12	30.00	PASS
High	2452	14.32	14.80	17.57	30.00	PASS

Remark:

1. At final test to get the worst-case emission at 13.5Mbps.
2. The cable assembly insertion loss of 11.2dB (including 10 dB pad and 1.2 dB cable) was Entered as an offset in the spectrum analyzer to allow for direct reading of power.



MAXIMUM PEAK OUTPUT POWER (IEEE 802.11b mode)

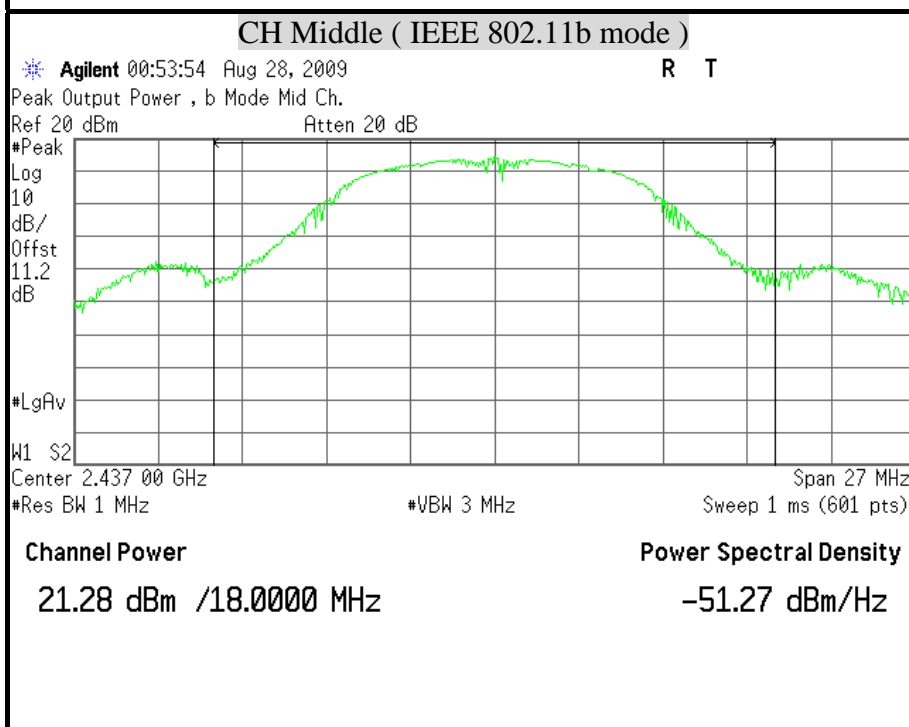
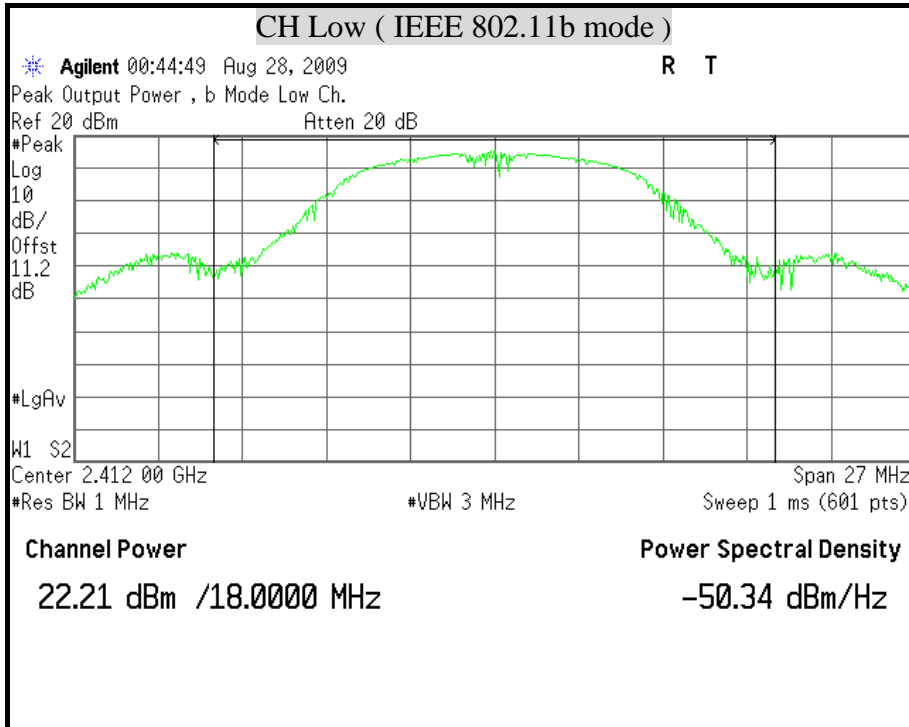

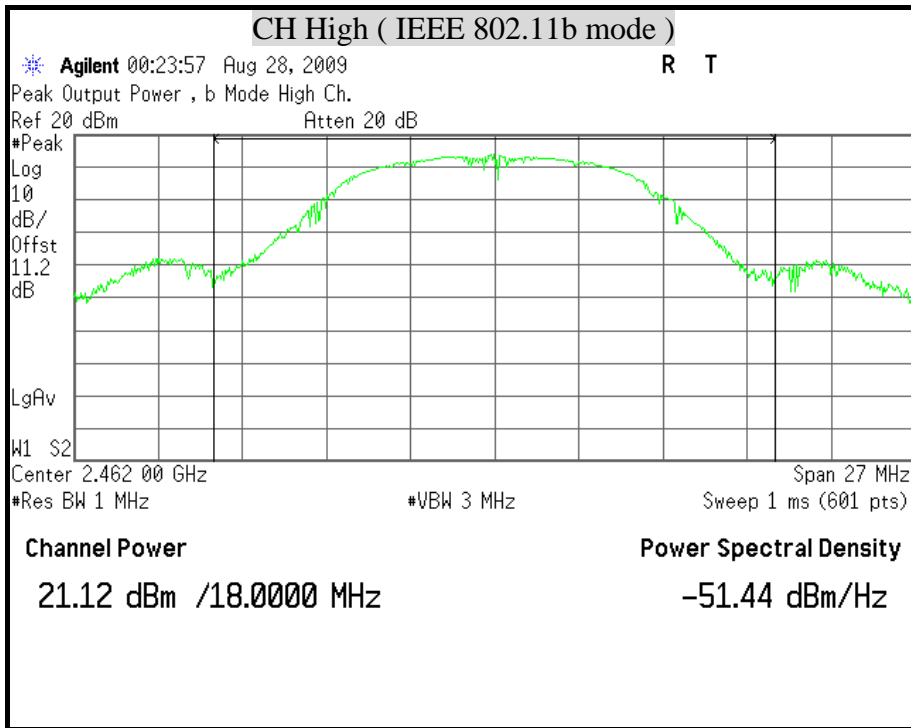



MAXIMUM PEAK OUTPUT POWER (IEEE 802.11g mode)

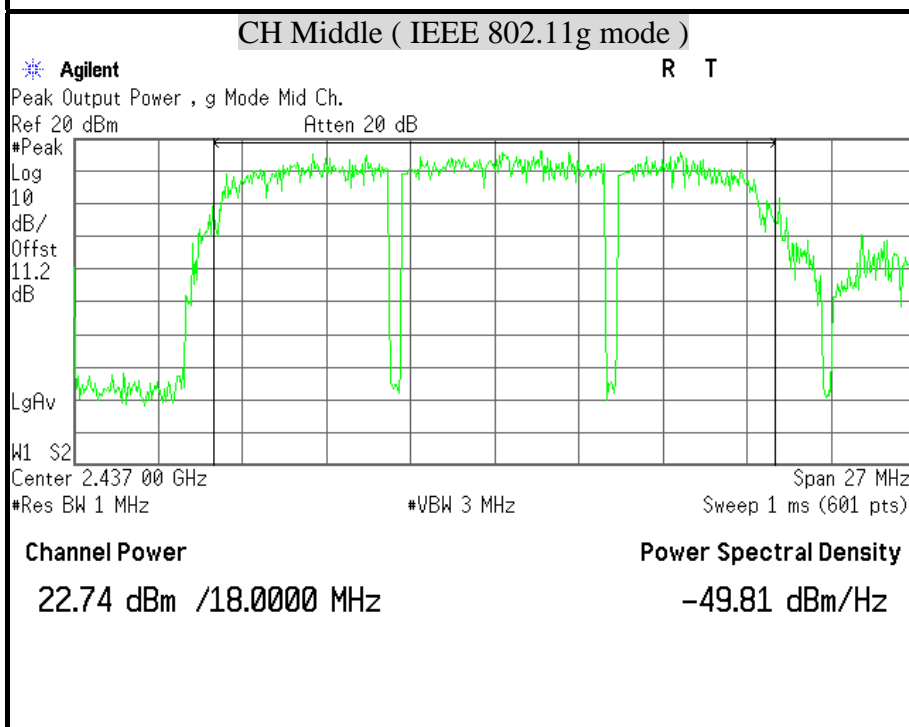
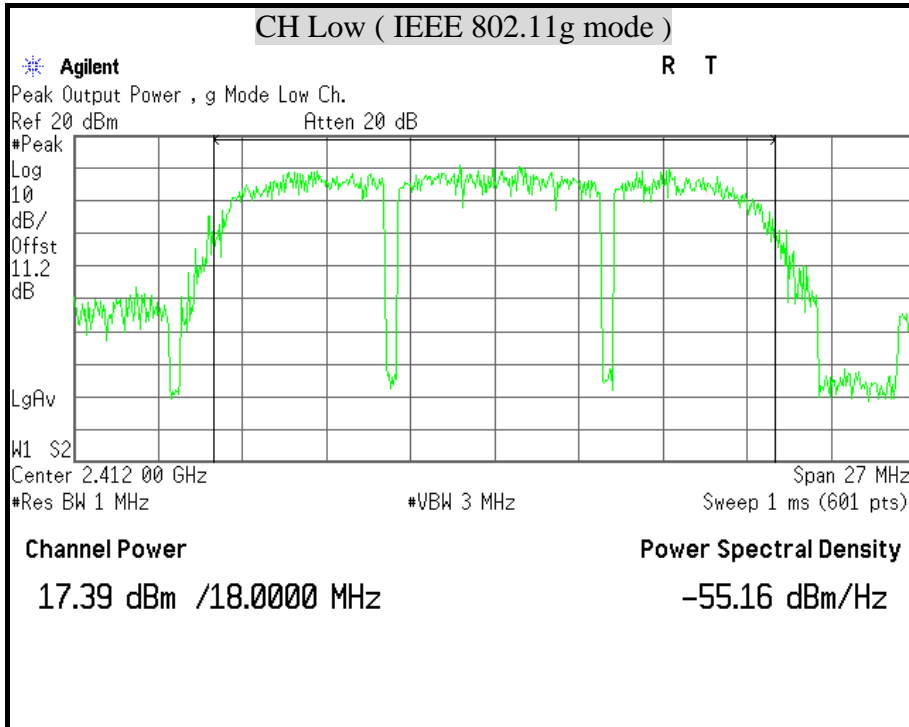

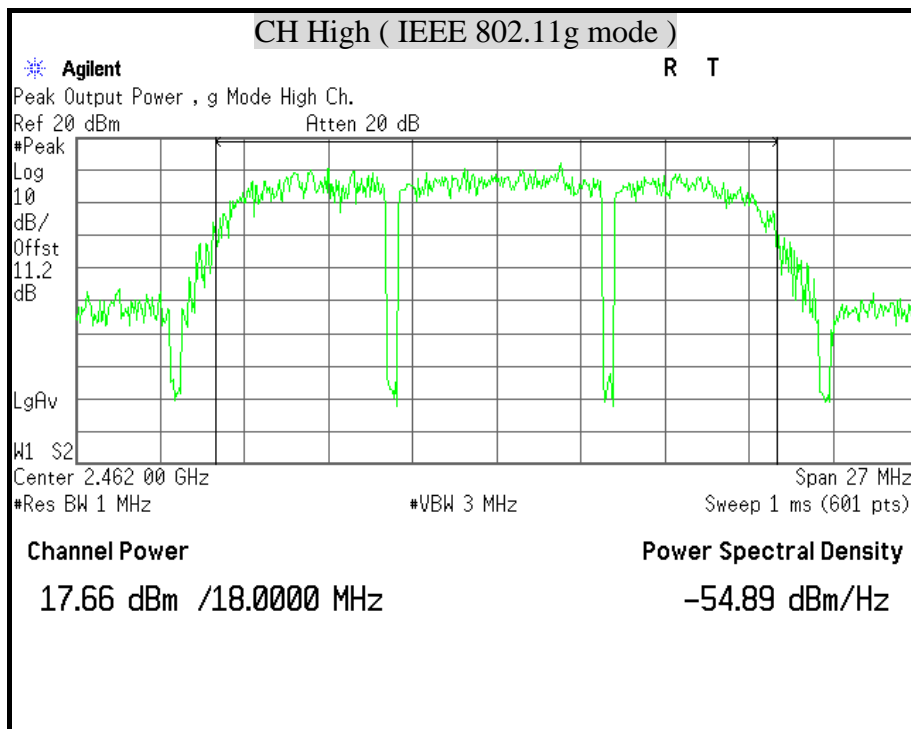



MAXIMUM PEAK OUTPUT POWER (IEEE 802.11n HT20 mode)

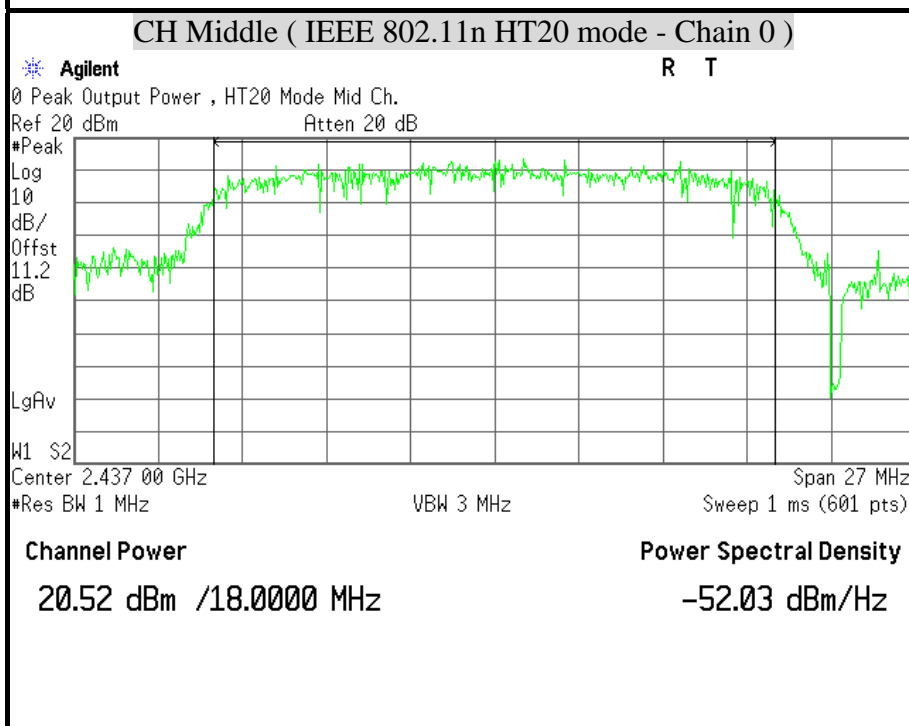
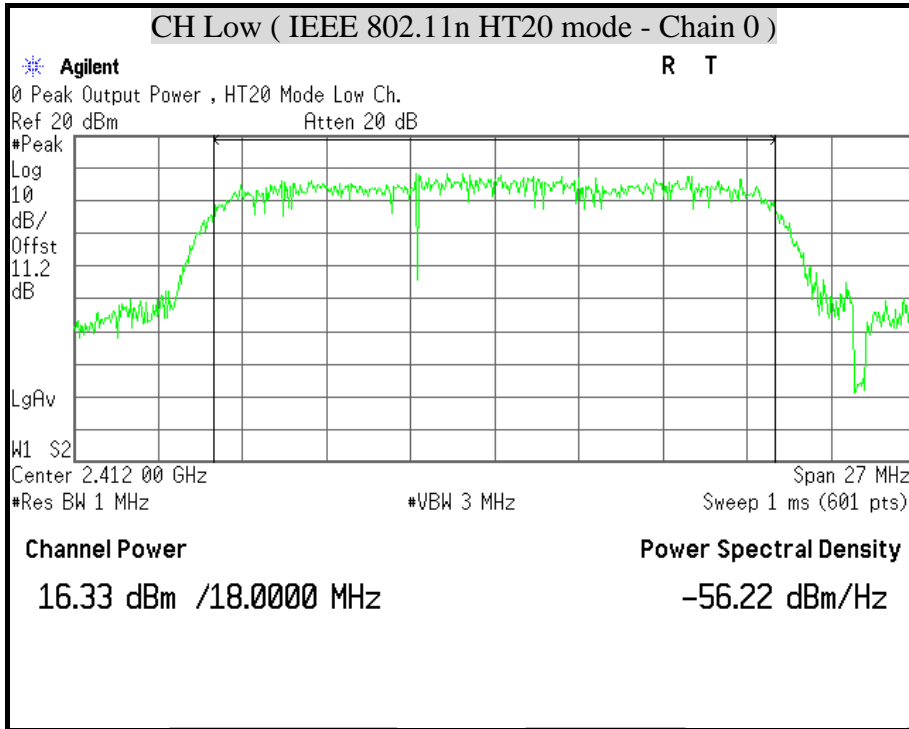

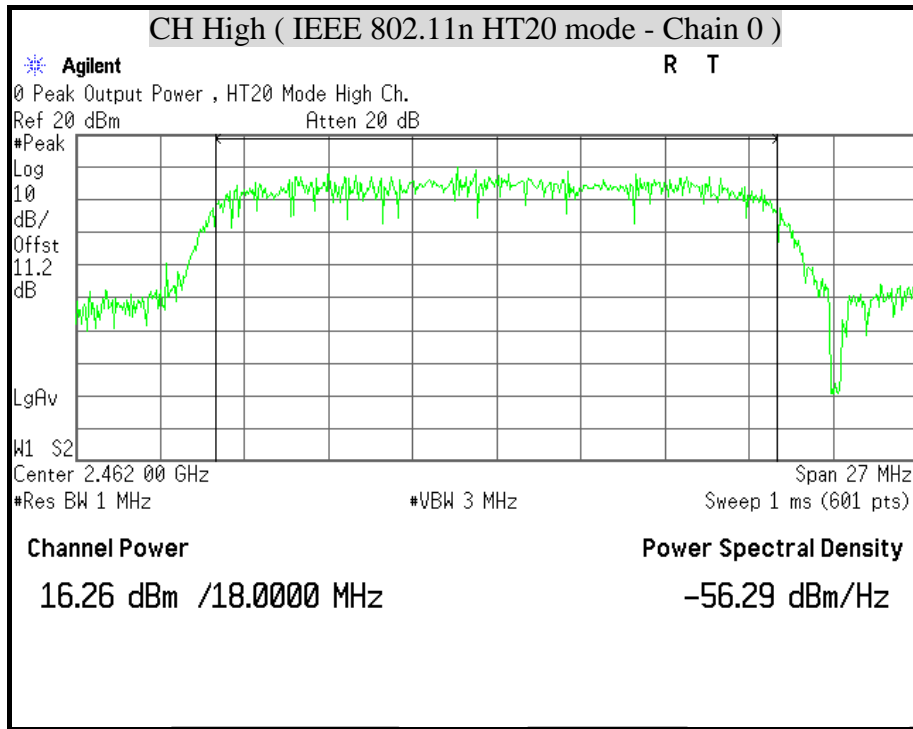

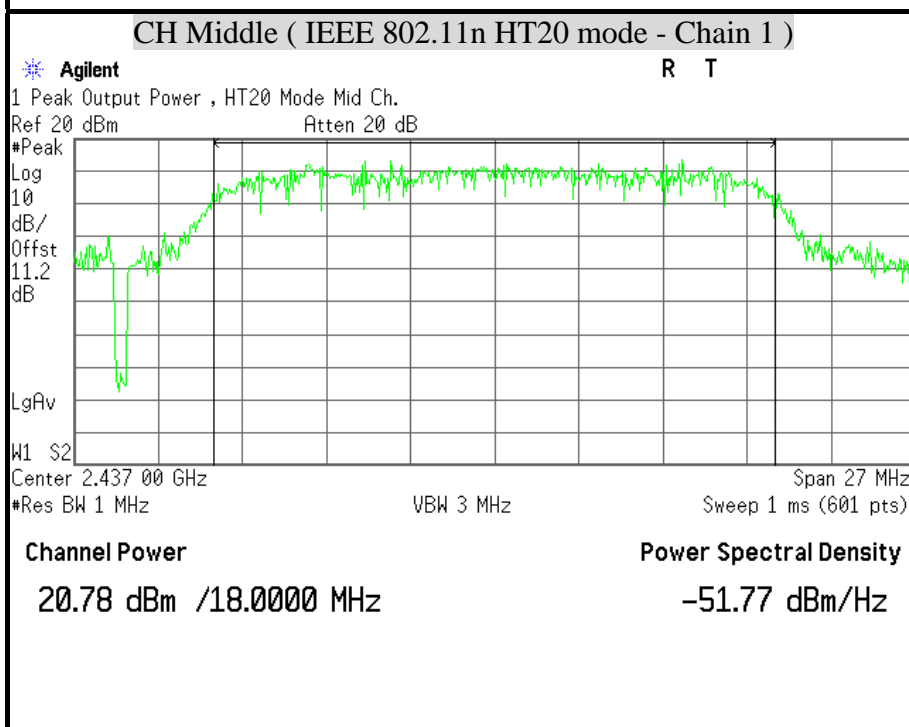
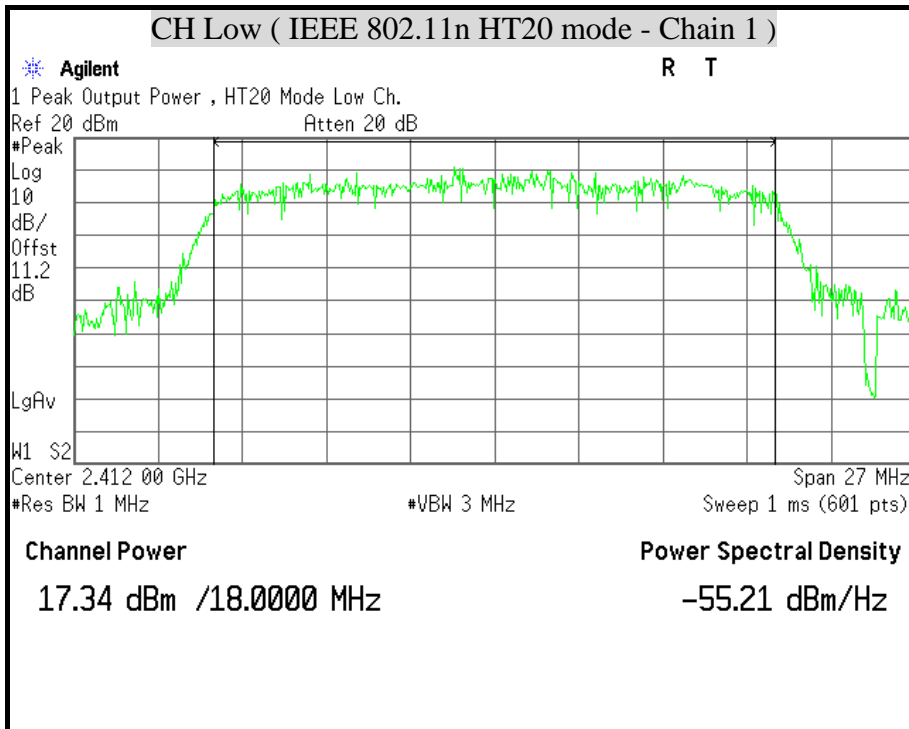

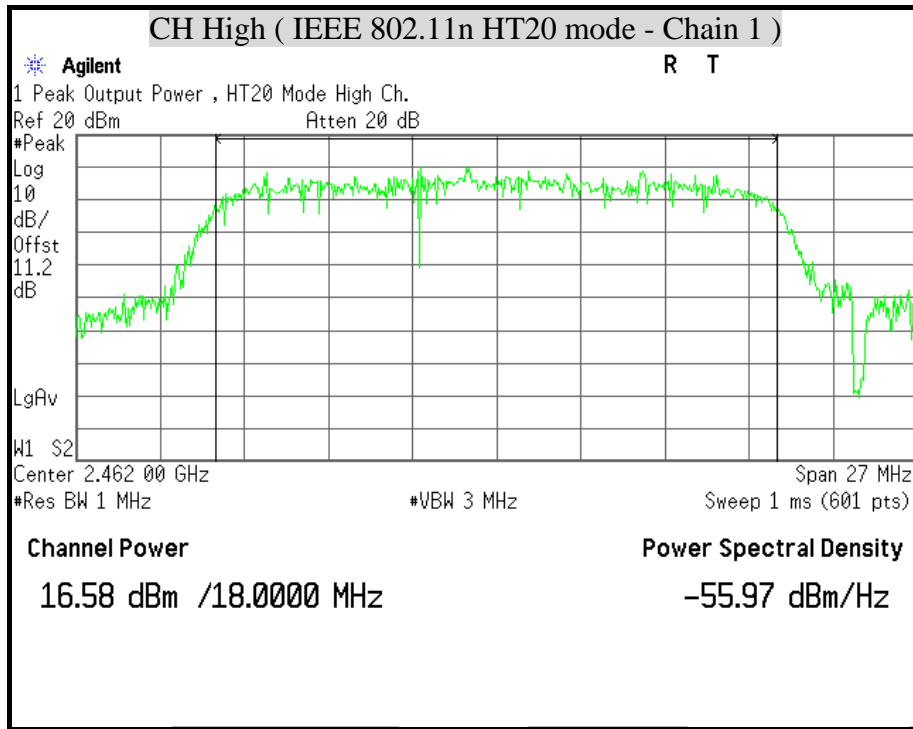



MAXIMUM PEAK OUTPUT POWER (IEEE 802.11n HT40 mode)

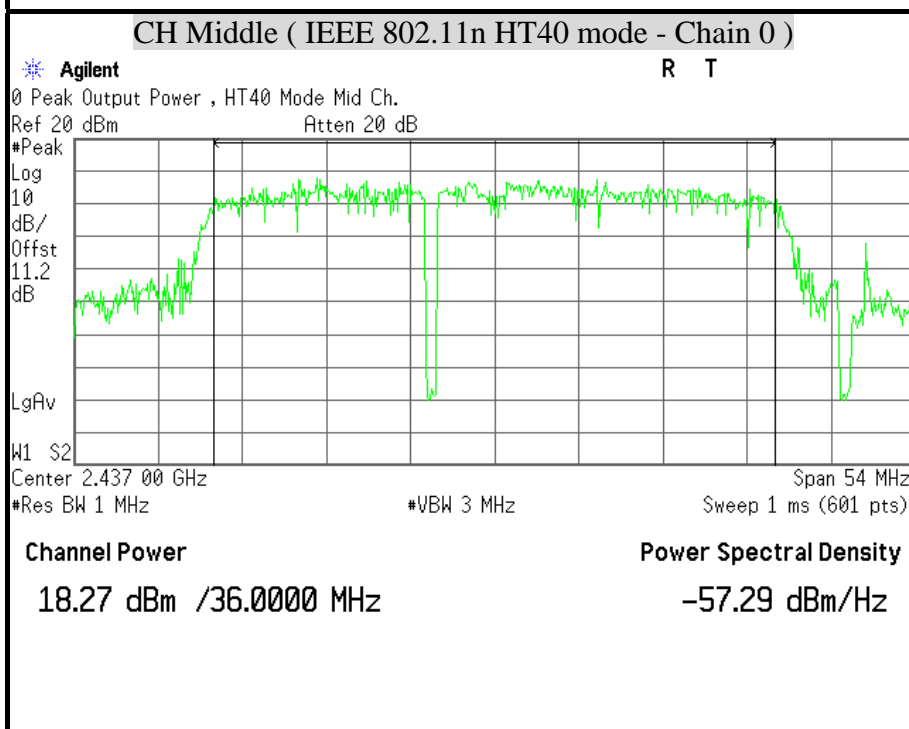
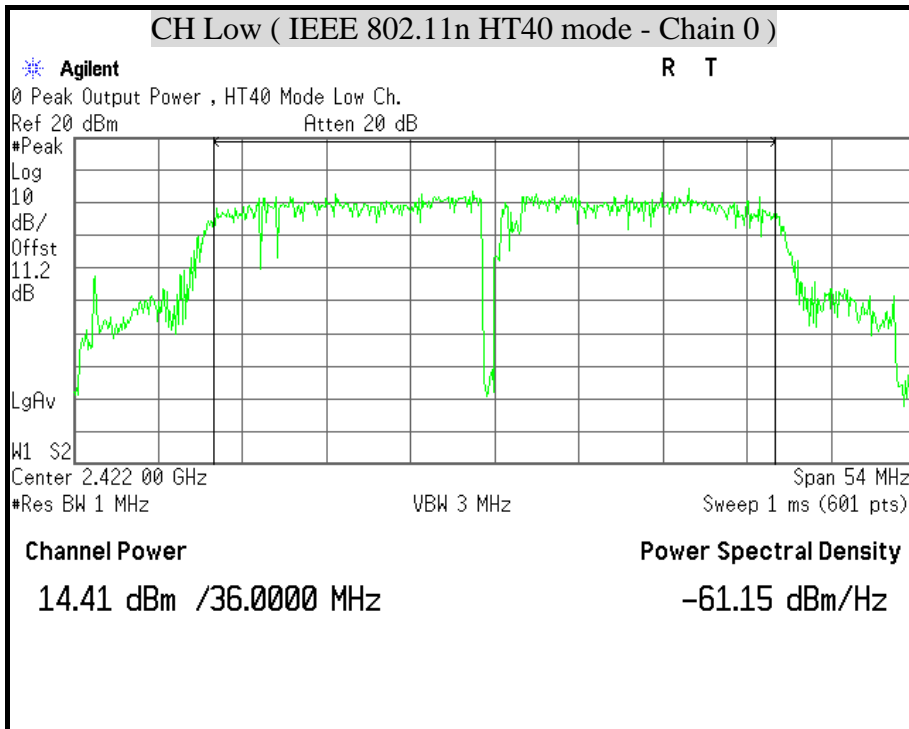

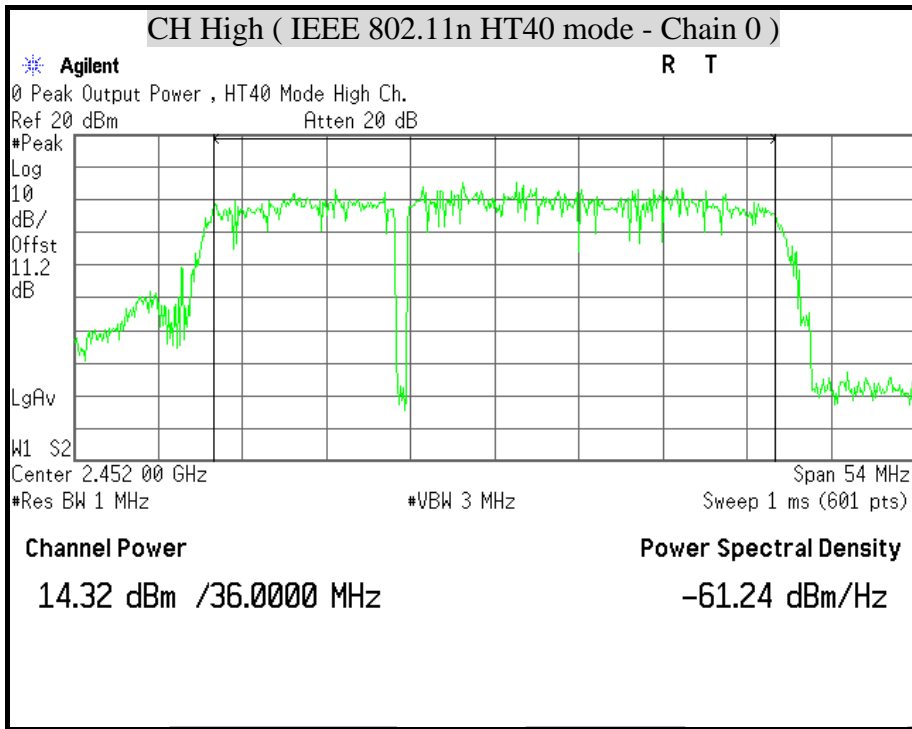

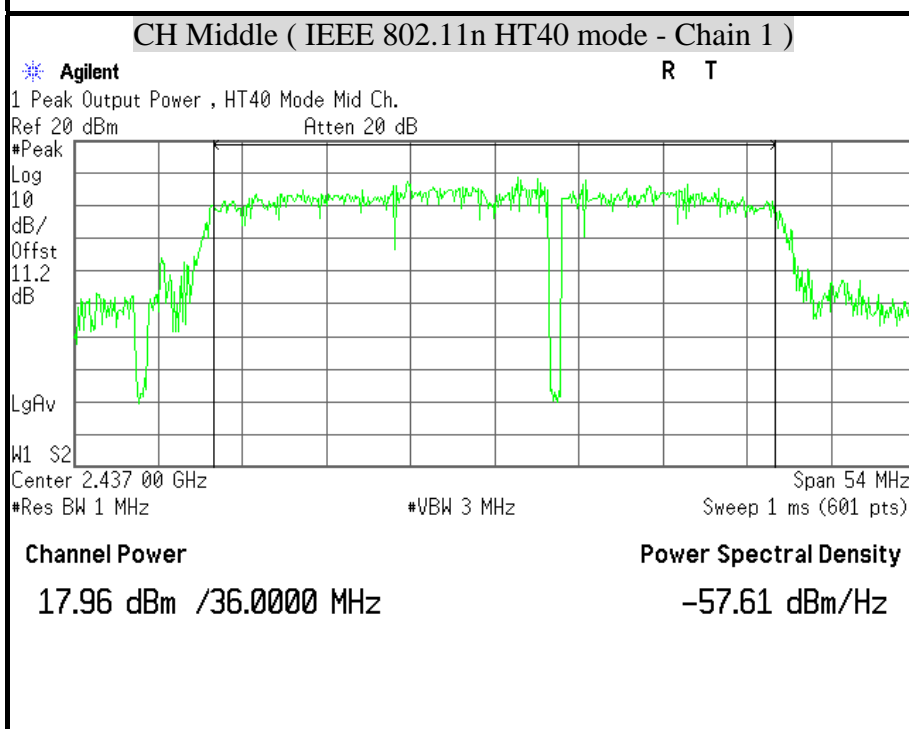
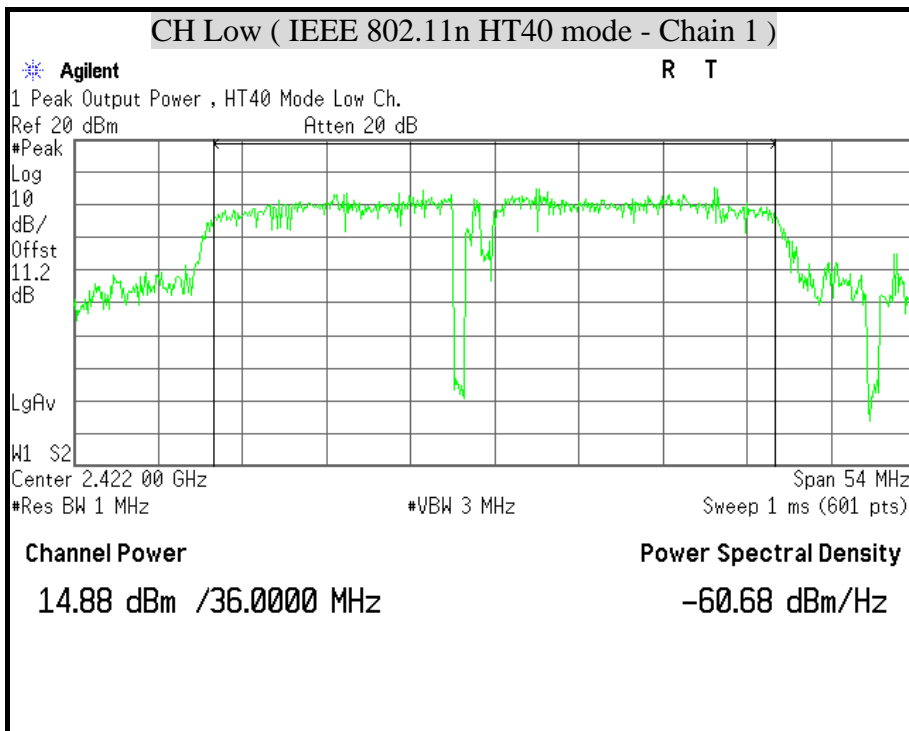

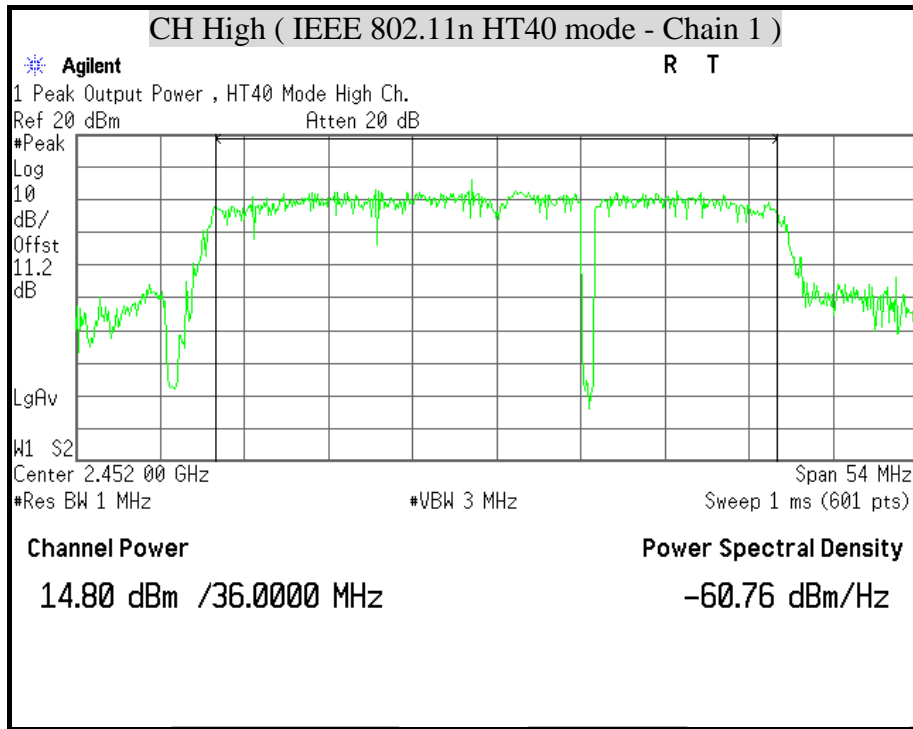



8.4 MAXIMUM PERMISSIBLE EXPOSURE

According to FCC 1.1310 : The criteria listed in the following table shall be used to evaluate the environment impact of human exposure to radio frequency (RF) radiation as specified in 1.1307(b) LIMITS FOR MAXIMUM PERMISSIBLE EXPOSURE (MPE)

Frequency Range (MHz)	Electric Field Strength (V/m)	Magnetic Field Strength (A/m)	Power Density (mW/cm ²)	Average Time
(A) Limits for Occupational / Control Exposures				
300-1,500	--	--	F/300	6
1,500-100,000	--	--	5	6
(B) Limits for General Population / Uncontrol Exposures				
300-1,500	--	--	F/1500	6
1,500-100,000	--	--	1	30

CALCULATIONS

Given $E = \frac{\sqrt{30 \times P \times G}}{d}$ & $S = \frac{E^2}{3770}$

Where $E =$ Field strength in Volts / meter

$P =$ Power in Watts

$G =$ Numeric antenna gain

$d =$ Distance in meters

$S =$ Power density in milliwatts / square centimeter

Combining equations and re-arranging the terms to express the distance as a function of the remaining variables yields:

$$S = \frac{30 \times P \times G}{3770d^2}$$

Changing to units of mW and cm, using:

$$P (mW) = P (W) / 1000 \text{ and}$$

$$d (cm) = d(m) / 100$$

Yields

$$S = \frac{30 \times (P/1000) \times G}{3770 \times (d/100)^2} = 0.0796 \times \frac{P \times G}{d^2}$$

Where $d =$ Distance in cm

$P =$ Power in mW

$G =$ Numeric antenna gain

$S =$ Power density in mW / cm²

**LIMIT**Power Density Limit, $S=1.0\text{mW}/\text{cm}^2$ **TEST RESULTS**

Mode	Antenna Gain (dBi)	Minimum separation distance (cm)	Output Power (dBm)	Numeric antenna gain (dB)	Power Density Limit (mW/cm^2)	Power Density at 20cm (mW/cm^2)
IEEE 802.11b	1.8	20.0	22.21	1.51	1.00	0.050086
IEEE 802.11g	1.8	20.0	22.74	1.51	1.00	0.056587
IEEE 802.11n HT20	1.8	20.0	23.66	1.51	1.00	0.069939
IEEE 802.11n HT40	1.8	20.0	21.12	1.51	1.00	0.038969

Remark: For mobile or fixed location transmitters, the maximum power density is $1.0\text{ mW}/\text{cm}^2$ even if the calculation indicates that the power density would be larger.



8.5 AVERAGE POWER

LIMIT

None; for reporting purposes only.

TEST EQUIPMENT

Name of Equipment	Manufacturer	Model	Serial Number	Calibration Due
SPECTRUM ANALYZER	AGILENT	E4446A	MY43360132	06/09/2010
SPECTRUM ANALYZER	AGILENT	E4446A	MY46180323	05/26/2010

Remark: Each piece of equipment is scheduled for calibration once a year.

TEST SETUP

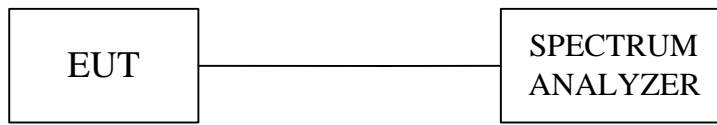

TEST PROCEDURE

The transmitter output is connected to a spectrum analyzer.

**TEST RESULTS**

Total avg power calculation formula:

$10 \log (10^{\text{Chain 0 Power / 10}} + 10^{\text{Chain 1 Power / 10}})$.

IEEE 802.11b mode

Channel	Channel Frequency (MHz)	Average Power Output (dBm)
Low	2412	19.61
Middle	2437	18.75
High	2462	18.55

Remark:

1. At final test to get the worst-case emission at 1Mbps.
2. The cable assembly insertion loss of 11.2dB (including 10 dB pad and 1.2 dB cable) was Entered as an offset in the spectrum analyzer to allow for direct reading of power.

IEEE 802.11g mode

Channel	Channel Frequency (MHz)	Average Power Output (dBm)
Low	2412	13.73
Middle	2437	19.31
High	2462	13.85

Remark:

1. At final test to get the worst-case emission at 54Mbps.
2. The cable assembly insertion loss of 11.2dB (including 10 dB pad and 1.2 dB cable) was Entered as an offset in the spectrum analyzer to allow for direct reading of power.

**IEEE 802.11n HT20 mode (Two TX)**

Channel	Channel Frequency (MHz)	Average Power (dBm)		Average Power Total (dBm)
		Chain 0	Chain 1	
Low	2412	12.67	13.55	16.14
Middle	2437	16.91	16.95	19.94
High	2462	12.67	13.01	15.85

Remark:

1. At final test to get the worst-case emission at 6.5Mbps.
2. The cable assembly insertion loss of 11.2dB (including 10 dB pad and 1.2 dB cable) was Entered as an offset in the spectrum analyzer to allow for direct reading of power.

IEEE 802.11n HT40 mode (Two TX)

Channel	Channel Frequency (MHz)	Average Power (dBm)		Average Power Total (dBm)
		Chain 0	Chain 1	
Low	2422	10.55	10.86	13.71
Middle	2437	14.89	14.43	17.67
High	2452	10.78	10.90	13.85

Remark:

1. At final test to get the worst-case emission at 13.5Mbps.
2. The cable assembly insertion loss of 11.2dB (including 10 dB pad and 1.2 dB cable) was Entered as an offset in the spectrum analyzer to allow for direct reading of power.



8.6 POWER SPECTRAL DENSITY

LIMIT

§ 15.247(e) For digitally modulated systems, the power spectral density conducted from the intentional radiator to the antenna shall not greater than 8 dBm in any 3 kHz band during any time interval of continuous transmission.

TEST EQUIPMENT

Name of Equipment	Manufacturer	Model	Serial Number	Calibration Due
SPECTRUM ANALYZER	AGILENT	E4446A	MY43360132	06/09/2010
SPECTRUM ANALYZER	AGILENT	E4446A	MY46180323	05/26/2010

Remark: Each piece of equipment is scheduled for calibration once a year.

TEST SETUP

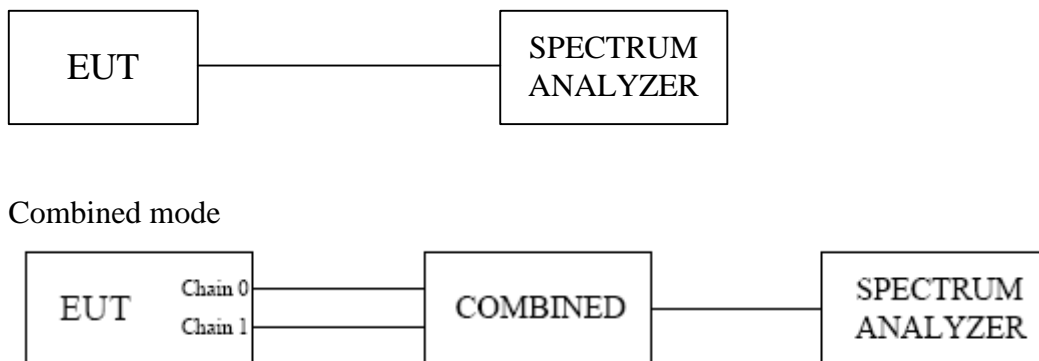

TEST PROCEDURE

The transmitter output was connected to the spectrum analyzer, the bandwidth of the fundamental frequency was measured with the spectrum analyzer using RBW = 3KHz and VBW = RBW, set sweep time = span / 3KHz.

The power spectral density was measured and recorded.

The sweep time is allowed to be longer than span / 3KHz for a full response of the mixer in the spectrum analyzer.

**TEST RESULTS**

Total peak power calculation formula:

$$10 \log (10^{\wedge} (\text{Chain 0 PPSD} / 10) + 10^{\wedge} (\text{Chain1 PPSD} / 10))$$

IEEE 802.11b mode

Channel	Channel Frequency (MHz)	Final RF Power Level in 3KHz BW (dBm)	Maxmum Limit (dBm)	Pass / Fail
Low	2412	-0.10	8	PASS
Middle	2437	-1.49	8	PASS
High	2462	-0.57	8	PASS

Remark:

1. At finial test to get the worst-case emission at 1Mbps.
2. The cable assembly insertion loss of 11.2dB (including 10 dB pad and 1.2 dB cable) was Entered as an offset in the spectrum analyzer to allow for direct reading of power.

IEEE 802.11g mode

Channel	Channel Frequency (MHz)	Final RF Power Level in 3KHz BW (dBm)	Maxmum Limit (dBm)	Pass / Fail
Low	2412	-9.70	8	PASS
Middle	2437	-4.01	8	PASS
High	2462	-8.83	8	PASS

Remark:

1. At finial test to get the worst-case emission at 54Mbps.
2. The cable assembly insertion loss of 11.2dB (including 10 dB pad and 1.2 dB cable) was Entered as an offset in the spectrum analyzer to allow for direct reading of power.

**IEEE 802.11n HT20 mode (Two TX)**

Channel	Channel Frequency (MHz)	Final RF Power Level in 3KHz BW (dBm)		PPSD Total (dBm)	Maximum Limit (dBm)	Pass / Fail
		Chain 0	Chain 1			
Low	2412	-10.41	-10.81	-7.59	8	PASS
Middle	2437	-7.52	-6.66	-4.05	8	PASS
High	2462	-10.69	-9.31	-6.93	8	PASS

Remark:

1. At final test to get the worst-case emission at 6.5Mbps.
2. The cable assembly insertion loss of 11.2dB (including 10 dB pad and 1.2 dB cable) was Entered as an offset in the spectrum analyzer to allow for direct reading of power.

IEEE 802.11n HT20 Combined mode (Two TX)

Channel	Channel Frequency (MHz)	Final RF Power Level in 3KHz BW (dBm)	Maximum Limit (dBm)	Pass / Fail
Low	2412	-8.57	8	PASS
Middle	2437	-3.58	8	PASS
High	2462	-7.95	8	PASS

Remark:

1. At final test to get the worst-case emission at 6.5Mbps.
2. The cable assembly insertion loss of 15dB (including 10 dB pad and 5dB cable) was Entered as an offset in the spectrum analyzer to allow for direct reading of power.

**IEEE 802.11n HT40 mode (Two TX)**

Channel	Channel Frequency (MHz)	Final RF Power Level in 3KHz BW (dBm)		PPSD Total (dBm)	Maximum Limit (dBm)	Pass / Fail
		Chain 0	Chain 1			
Low	2422	-14.75	-15.59	-12.13	8	PASS
Middle	2437	-11.25	-12.66	-8.88	8	PASS
High	2452	-15.18	-14.72	-11.93	8	PASS

Remark:

1. At final test to get the worst-case emission at 13.5Mbps.
2. The cable assembly insertion loss of 11.2dB (including 10 dB pad and 1.2 dB cable) was Entered as an offset in the spectrum analyzer to allow for direct reading of power.

IEEE 802.11n HT40 Combined mode (Two TX)

Channel	Channel Frequency (MHz)	Final RF Power Level in 3KHz BW (dBm)	Maximum Limit (dBm)	Pass / Fail
Low	2422	-11.80	8	PASS
Middle	2437	-8.61	8	PASS
High	2452	-12.03	8	PASS

Remark:

1. At final test to get the worst-case emission at 13.5Mbps.
2. The cable assembly insertion loss of 15dB (including 10 dB pad and 5dB cable) was Entered as an offset in the spectrum analyzer to allow for direct reading of power.



POWER SPECTRAL DENSITY (IEEE 802.11b mode)

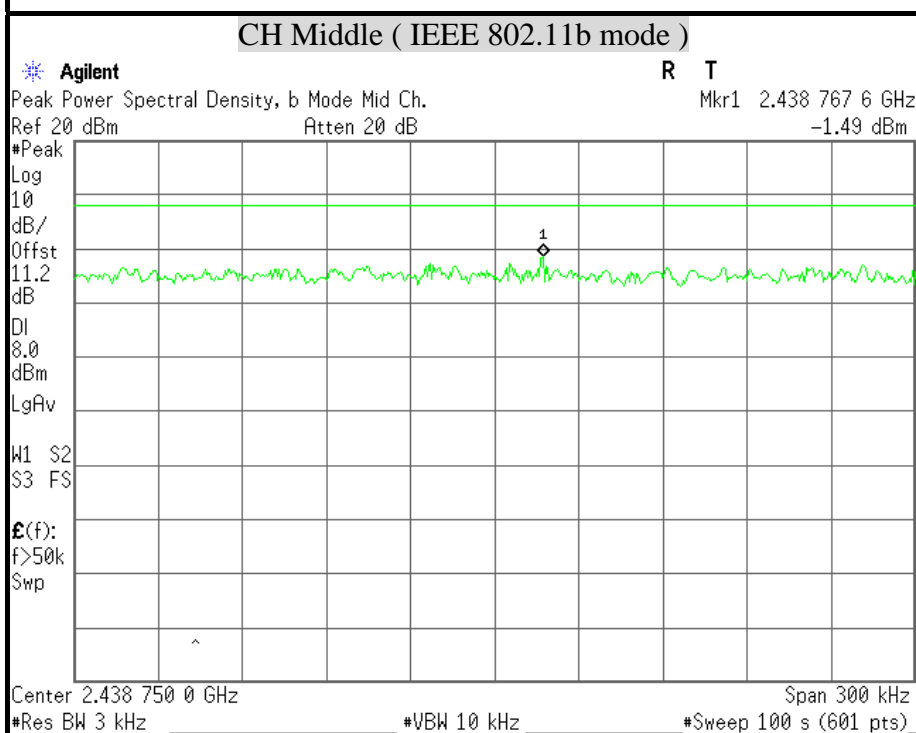
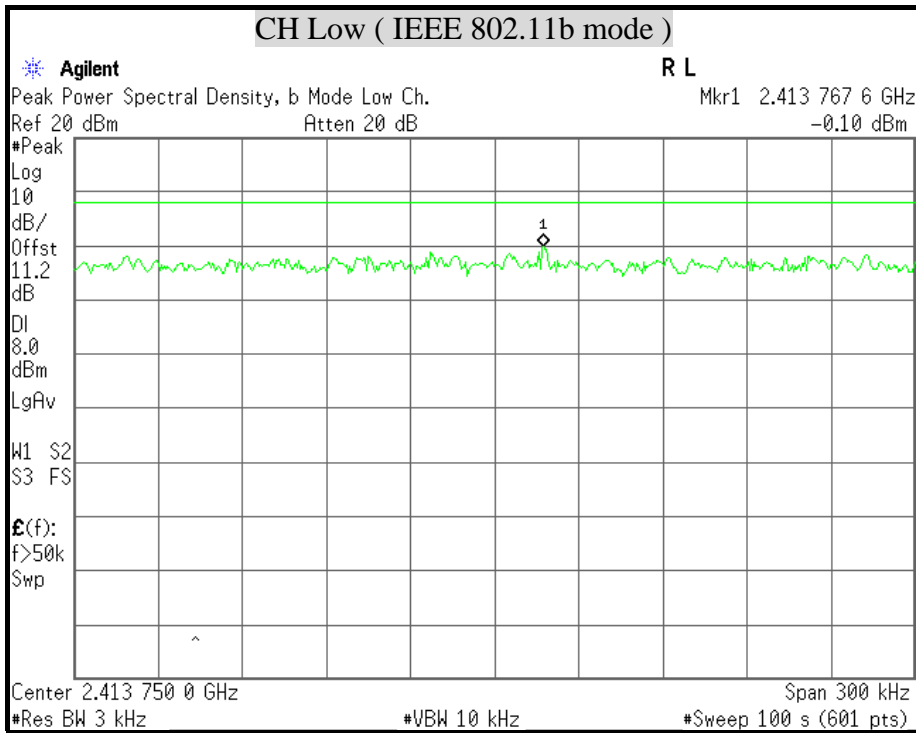

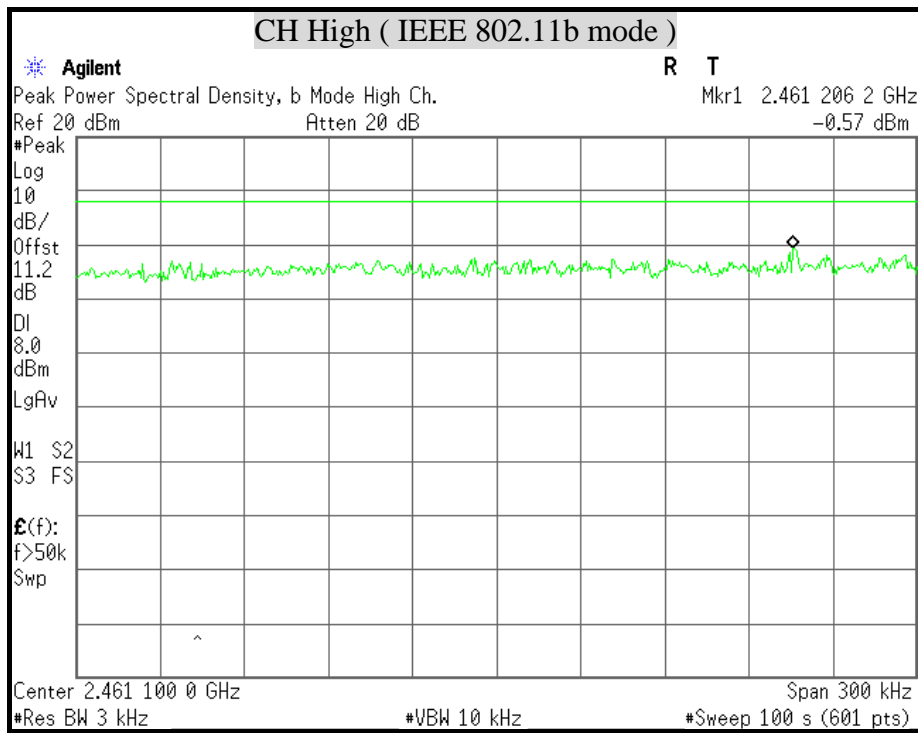



POWER SPECTRAL DENSITY (IEEE 802.11g mode)

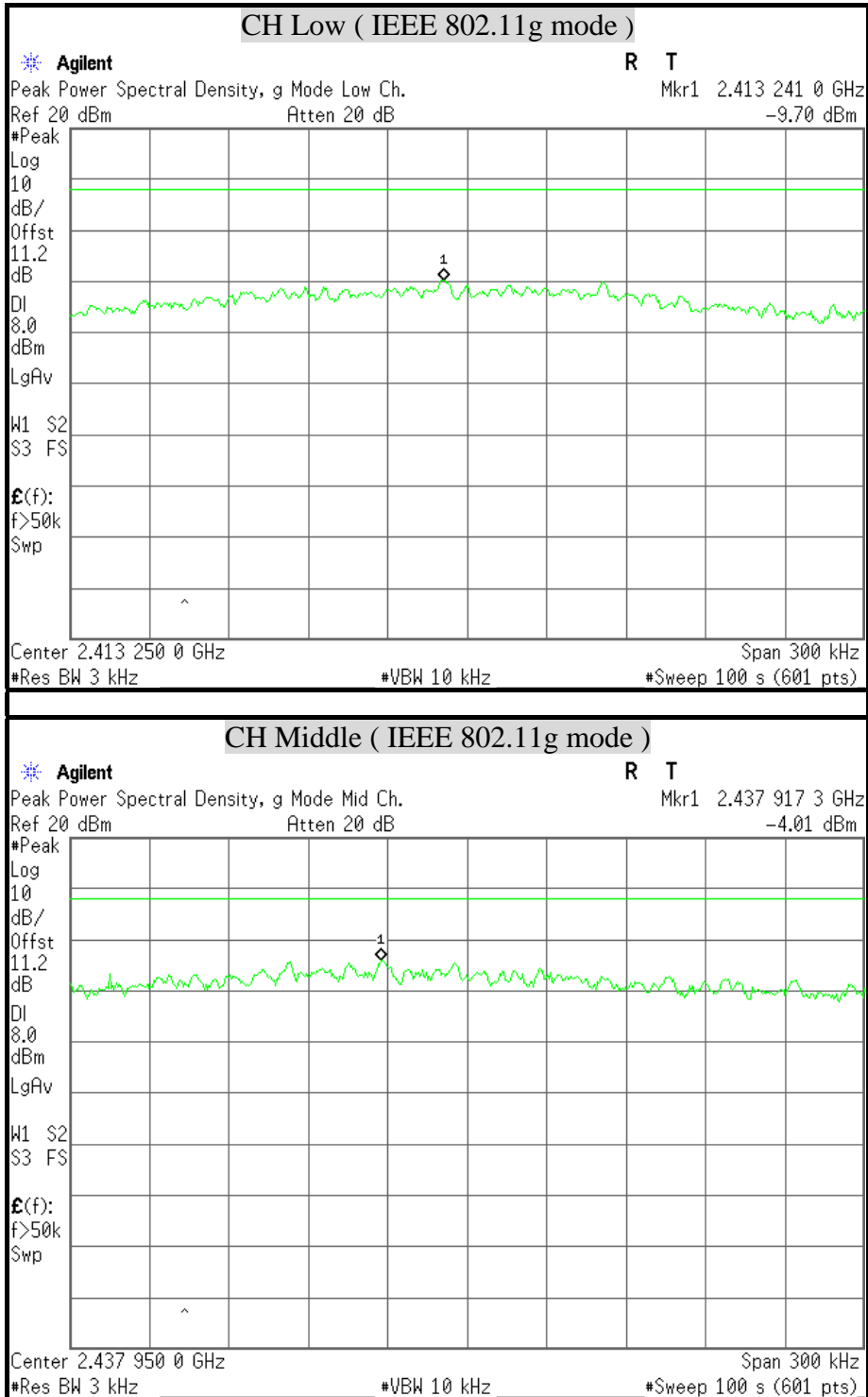

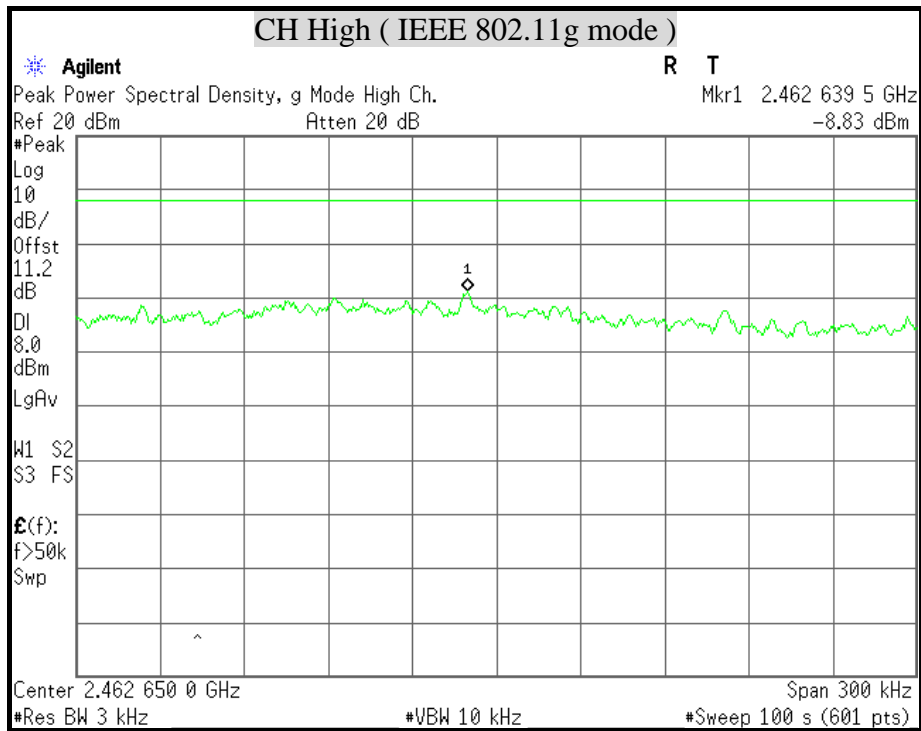



POWER SPECTRAL DENSITY (IEEE 802.11n HT20 mode)

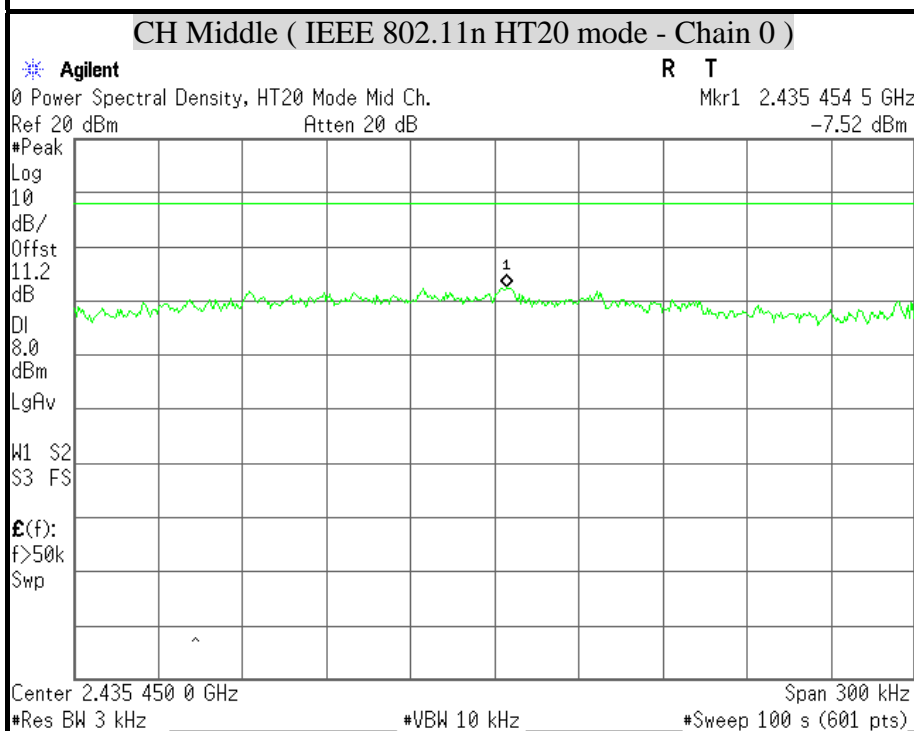
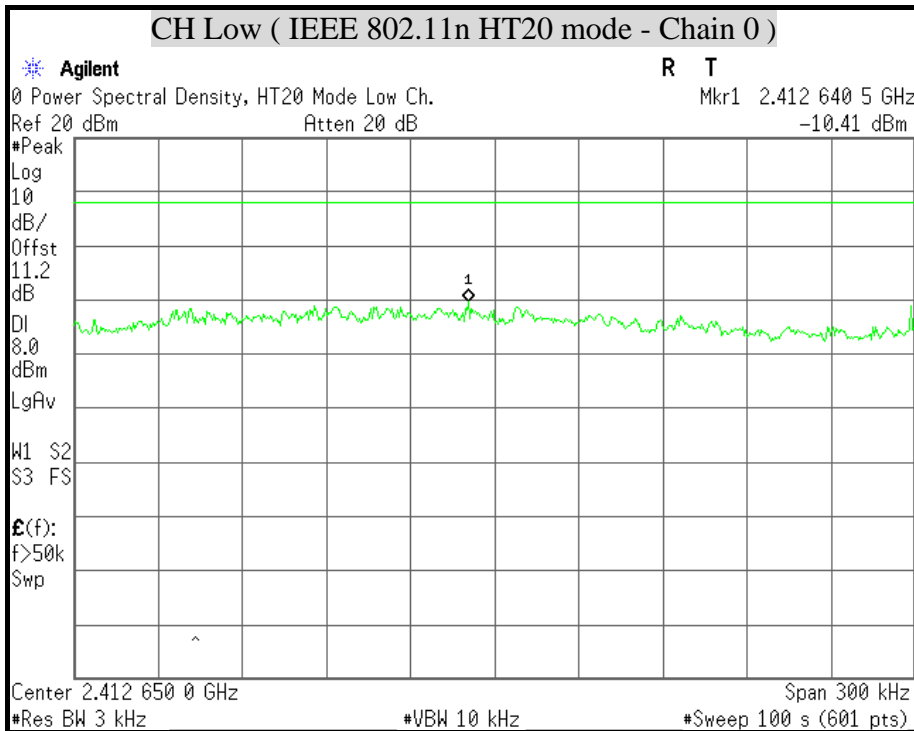

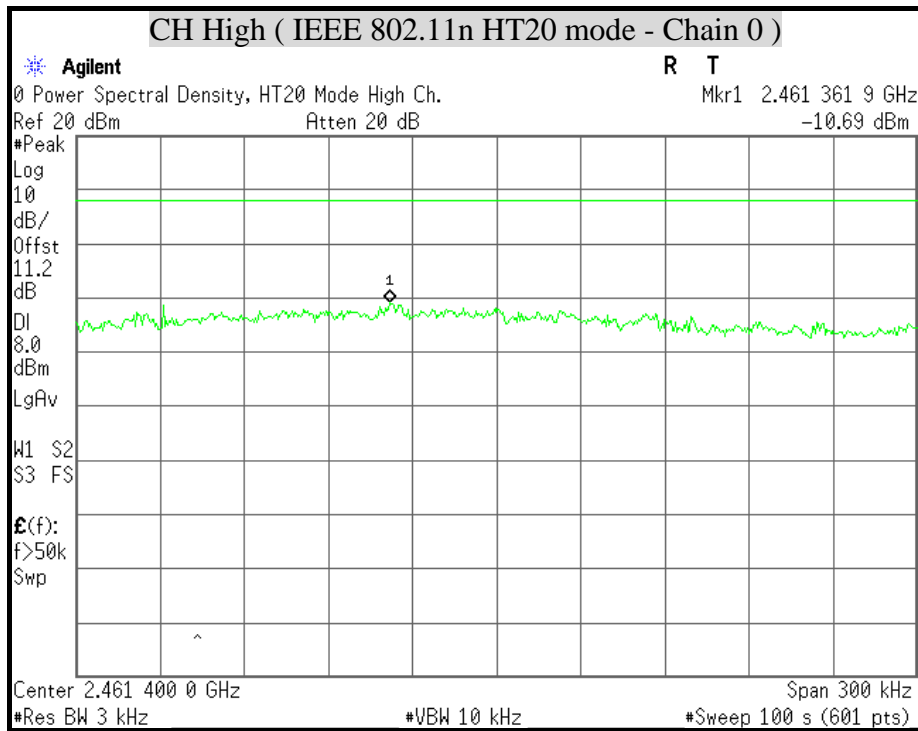

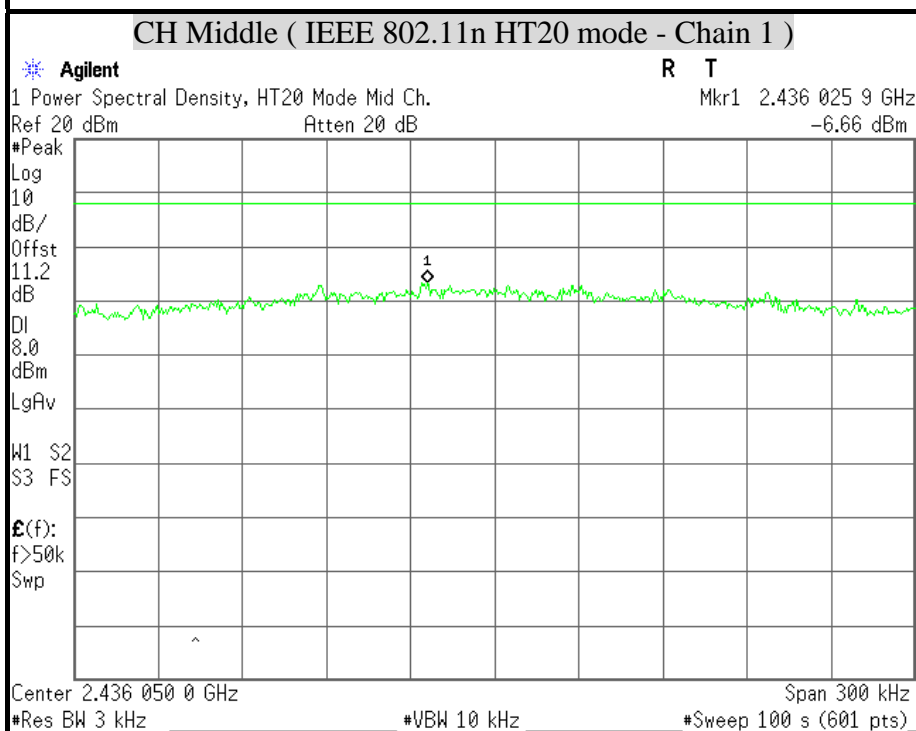
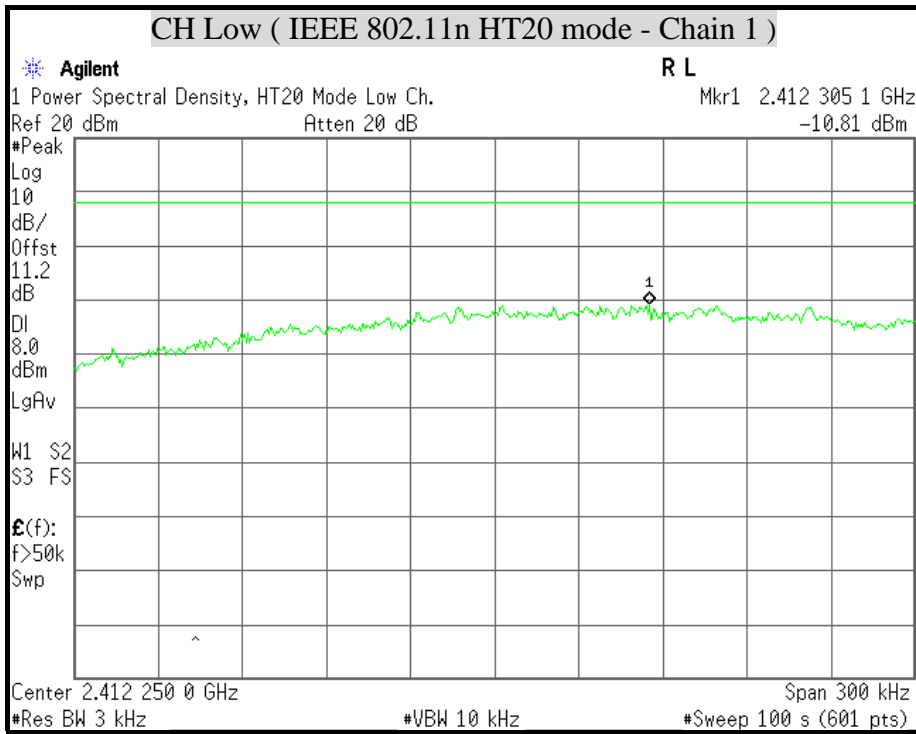

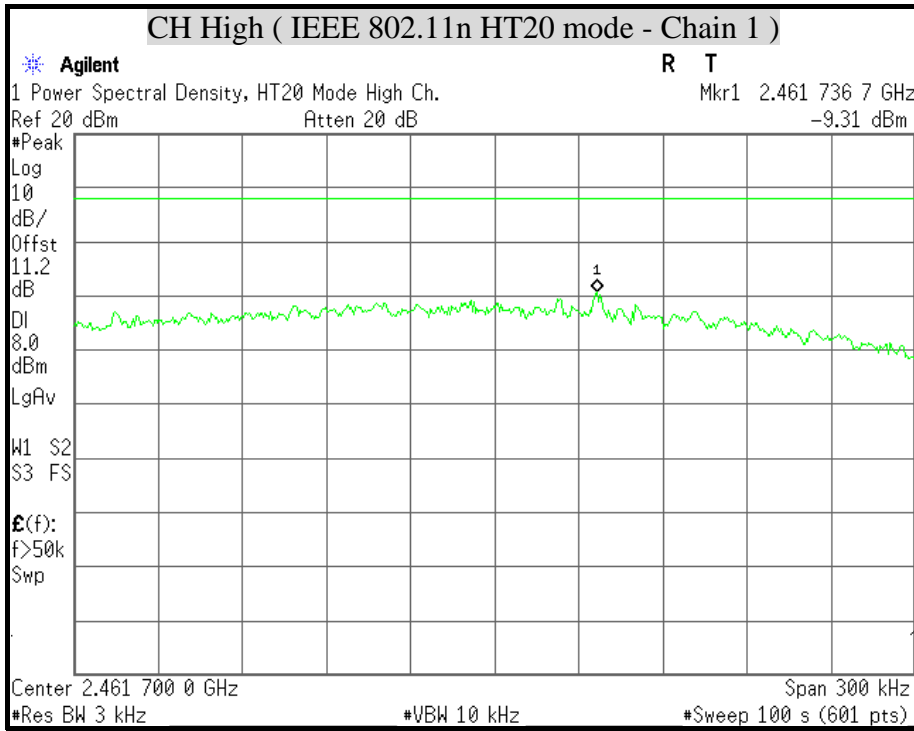



POWER SPECTRAL DENSITY (IEEE 802.11n HT20 Combined mode)

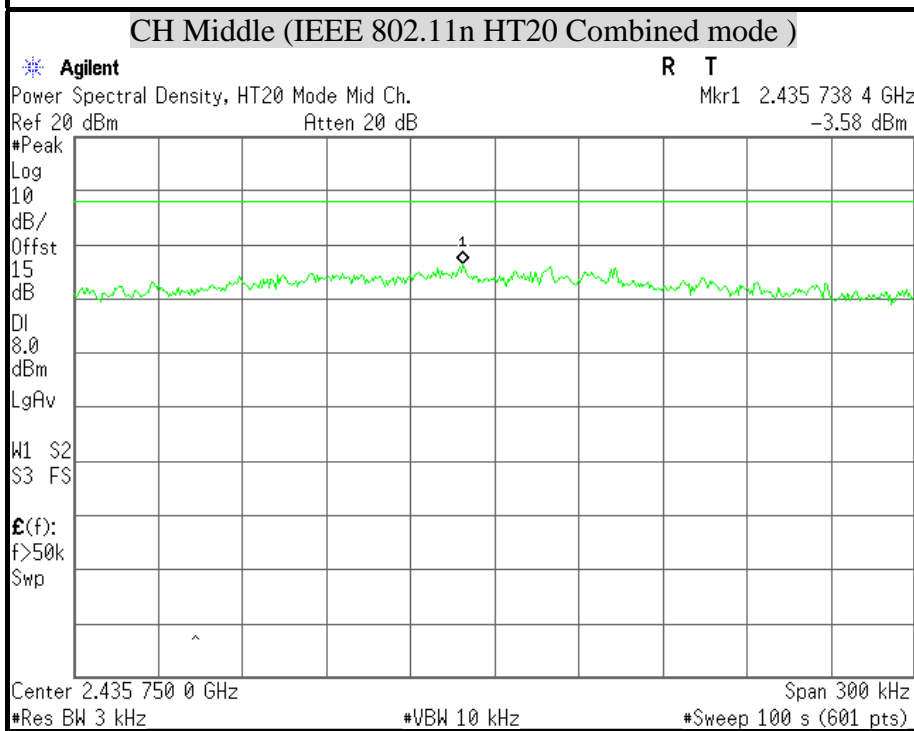
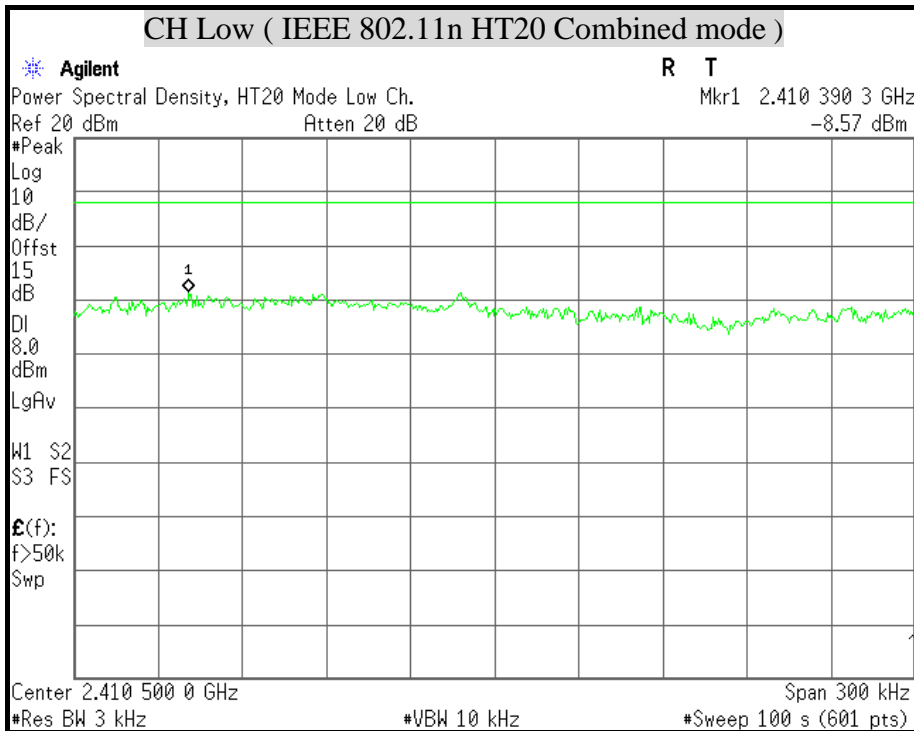

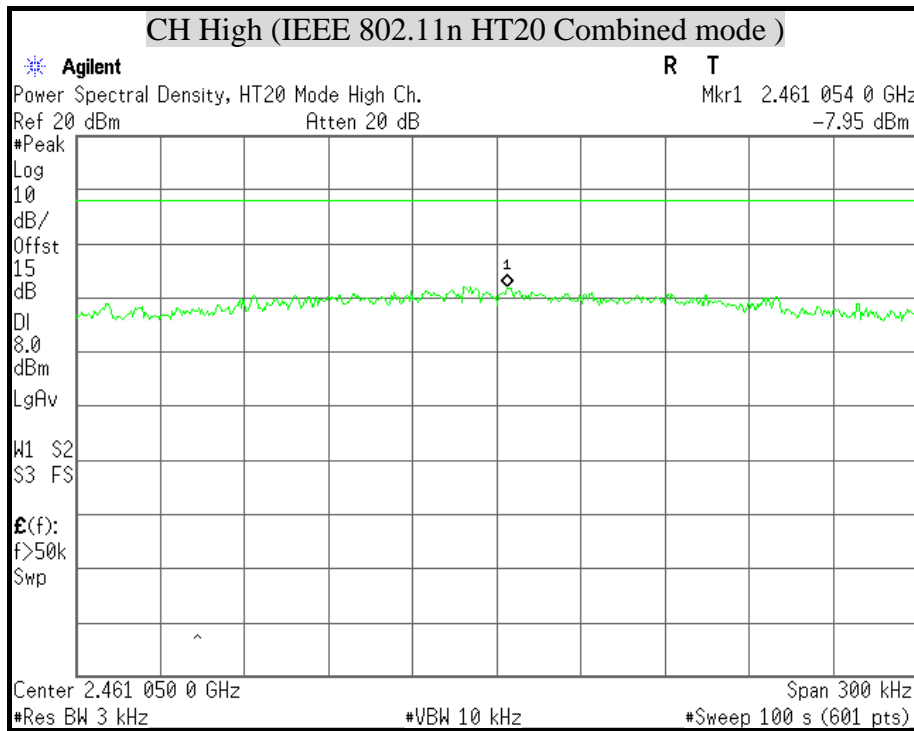



POWER SPECTRAL DENSITY (IEEE 802.11n HT40 mode)

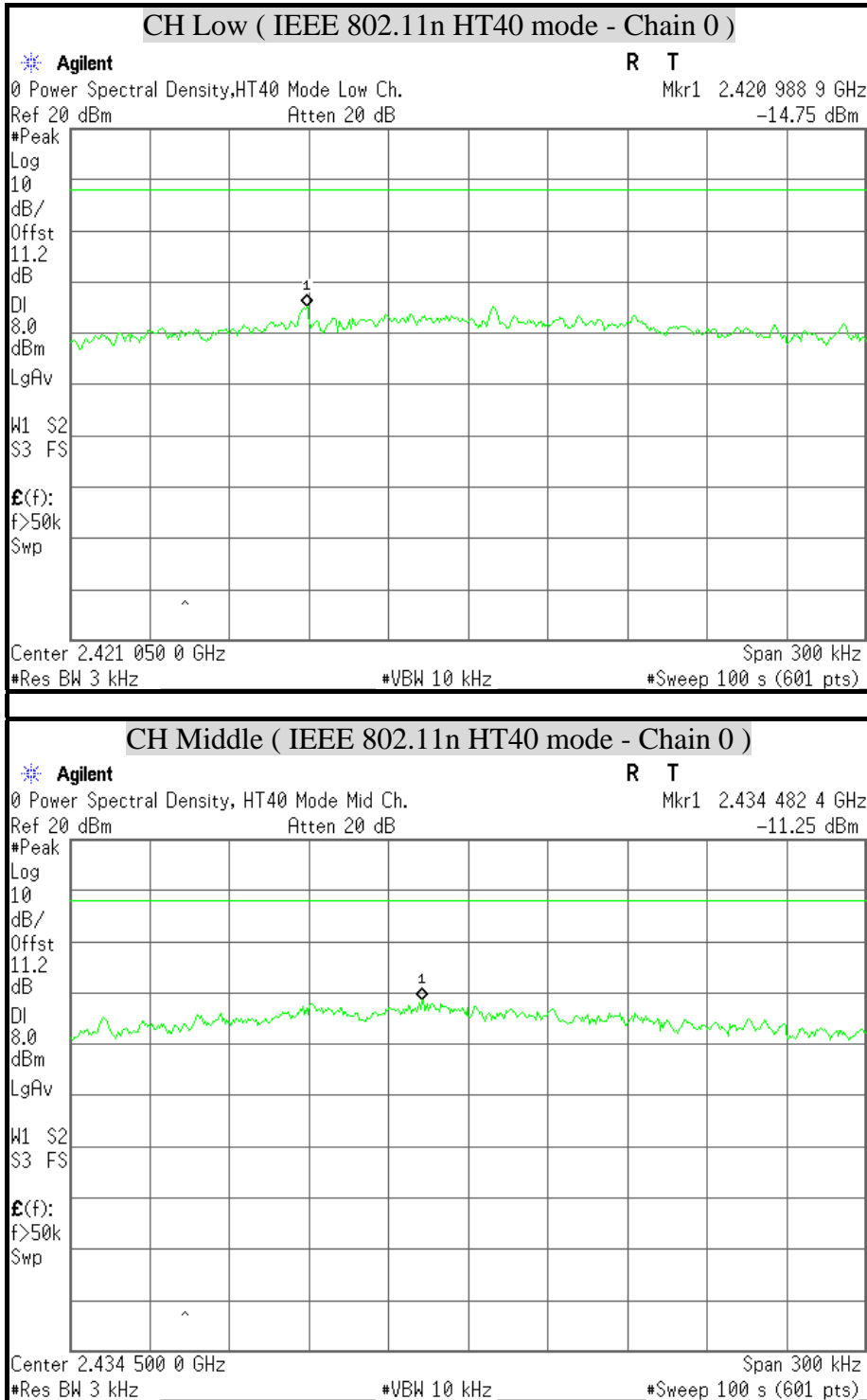

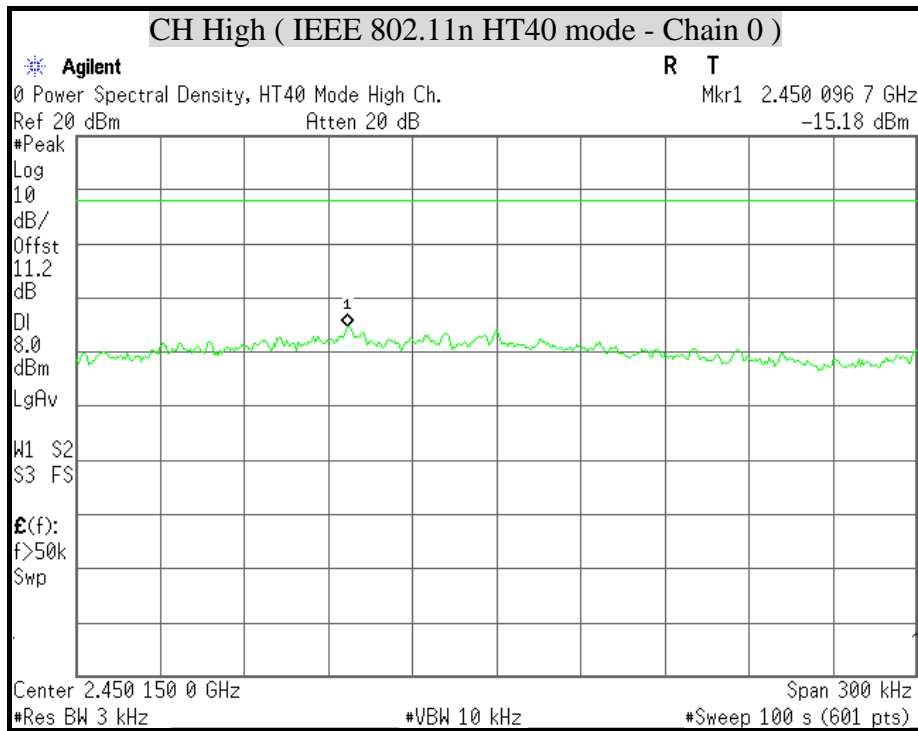

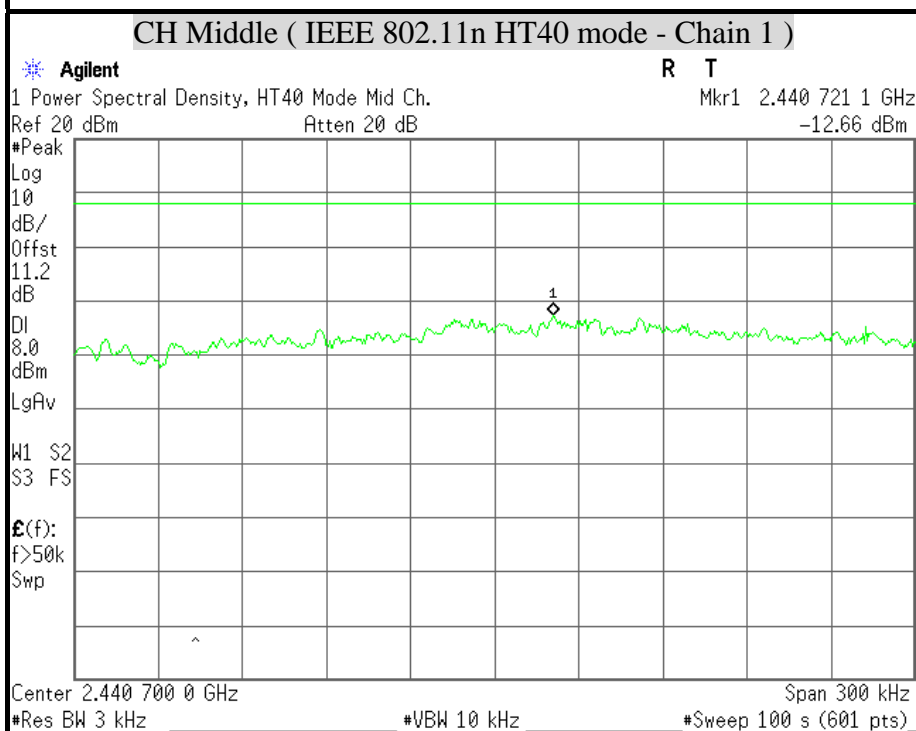
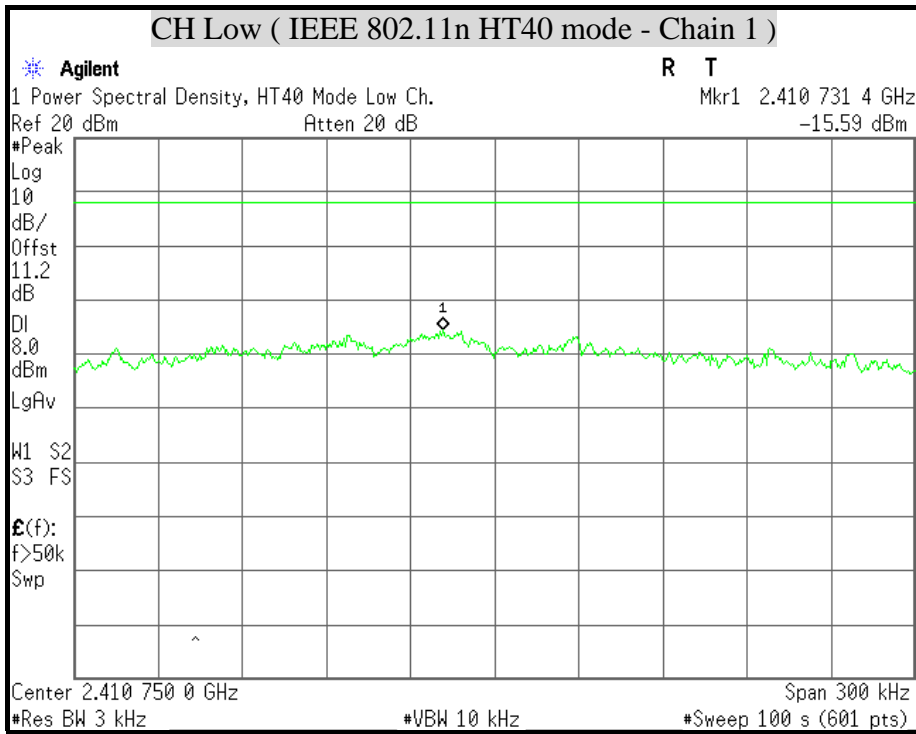

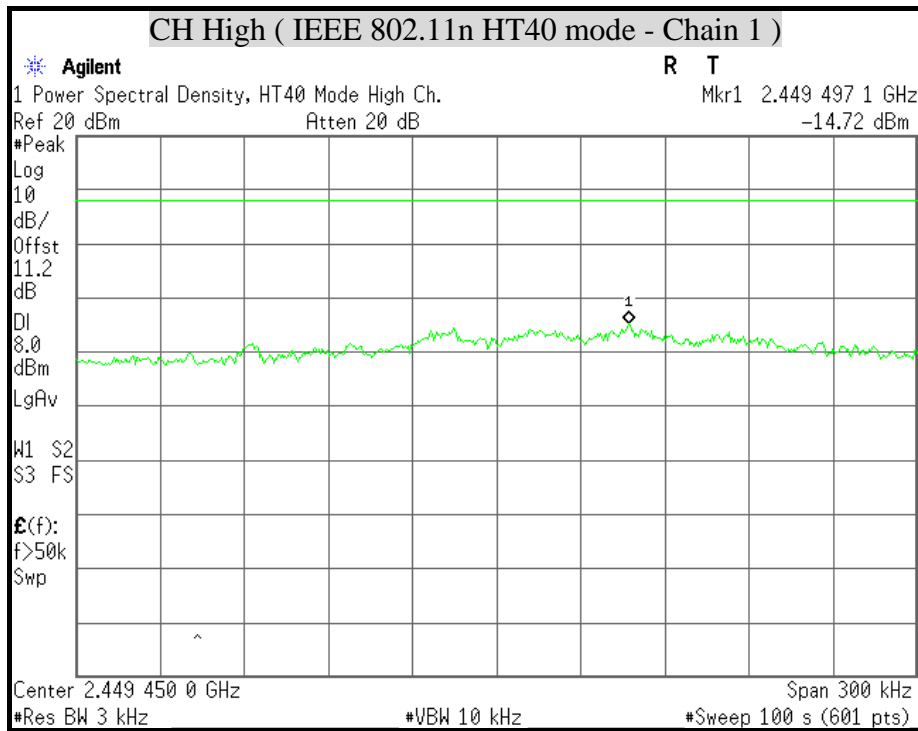



POWER SPECTRAL DENSITY (IEEE 802.11n HT40 Combined mode)

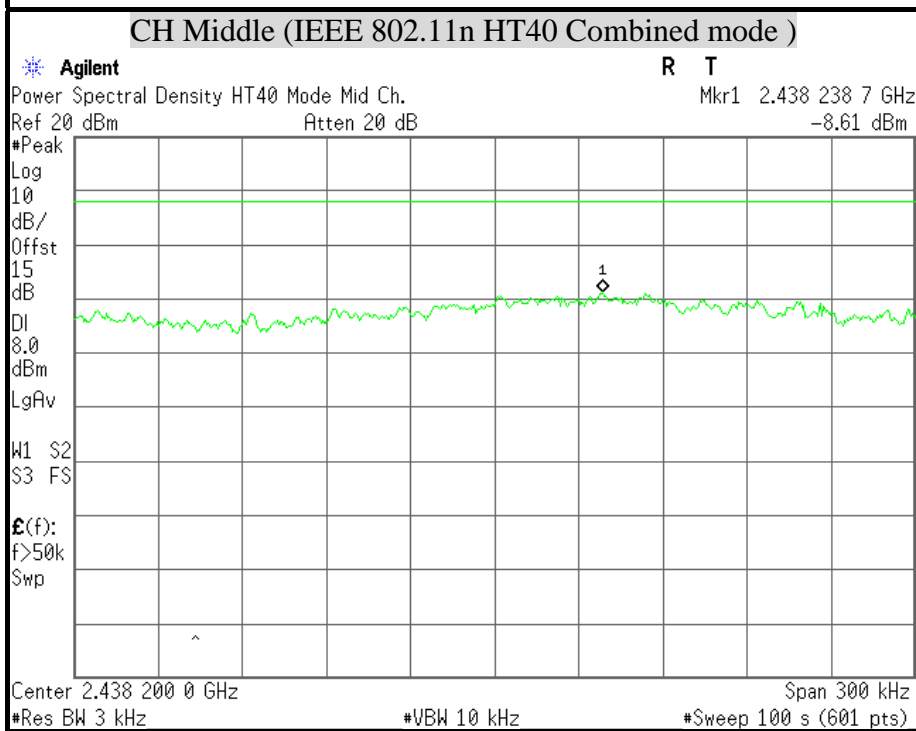
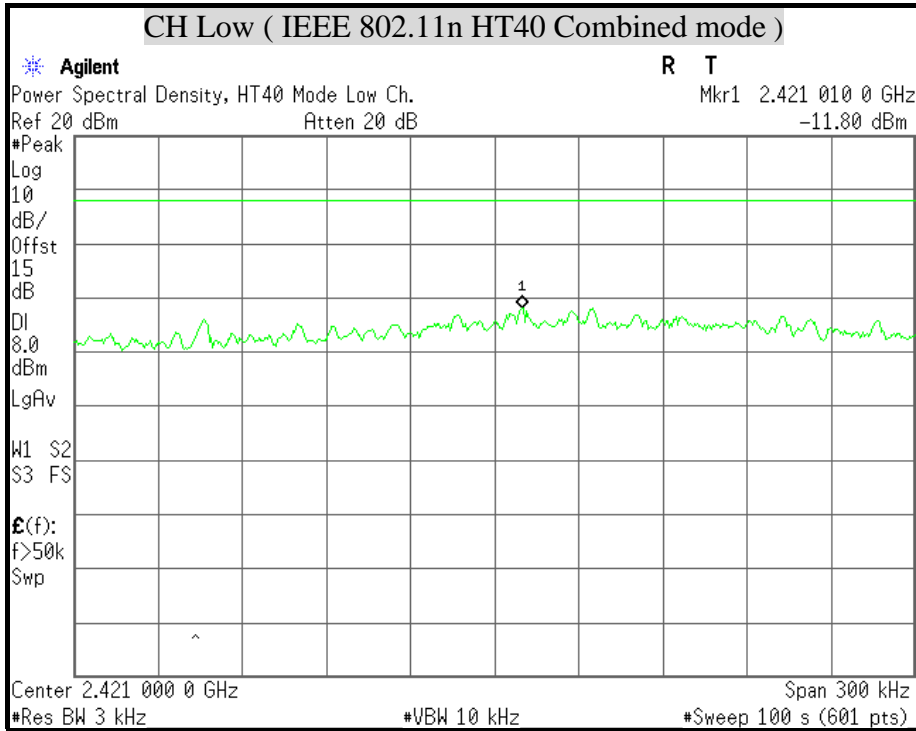

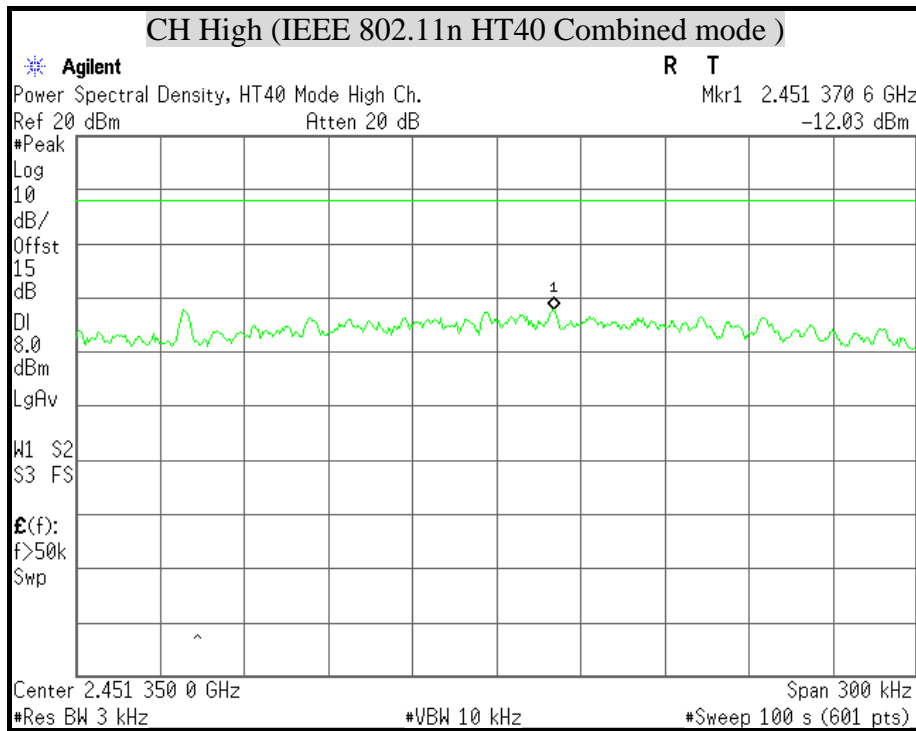



8.7 CONDUCTED SPURIOUS EMISSION

LIMITS

§ 15.247(d) In any 100 kHz bandwidth outside the frequency band in which the spread spectrum intentional radiator is operating, the radio frequency power that is produced by the intentional radiator shall be at least 20 dB below that in the 100 kHz bandwidth within the and that contains the highest level of the desired power, based on either an RF conducted or a radiated measurement. Attenuation below the general limits specified in § 15.209(a) is not required. In addition, radiated emissions which fall in the restricted bands, as defined in § 15.205(a), must also comply with the radiated emission limits specified in § 15.209(a) (see § 15.205(c)).

TEST EQUIPMENT

Name of Equipment	Manufacturer	Model	Serial Number	Calibration Due
SPECTRUM ANALYZER	AGILENT	E4446A	MY43360132	06/09/2010
SPECTRUM ANALYZER	AGILENT	E4446A	MY46180323	05/26/2010

Remark: Each piece of equipment is scheduled for calibration once a year.

TEST SETUP

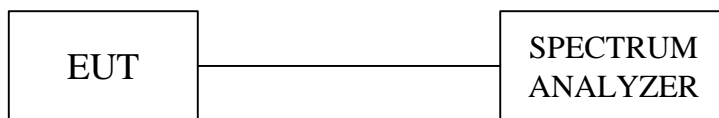

Combined mode

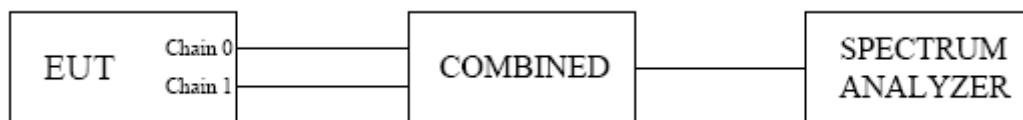

TEST PROCEDURE

The transmitter output is connected to a spectrum analyzer. The resolution bandwidth is set to 100 kHz. The video bandwidth is set to 300 kHz.

The spectrum from 30 MHz to 26 GHz is investigated with the transmitter set to the lowest, middle, and highest channels in the 2.4 GHz band.



TEST RESULTS

OUT-OF-BAND SPURIOUS EMISSIONS-CONDUCTED MEASUREMENT

(IEEE 802.11b mode)

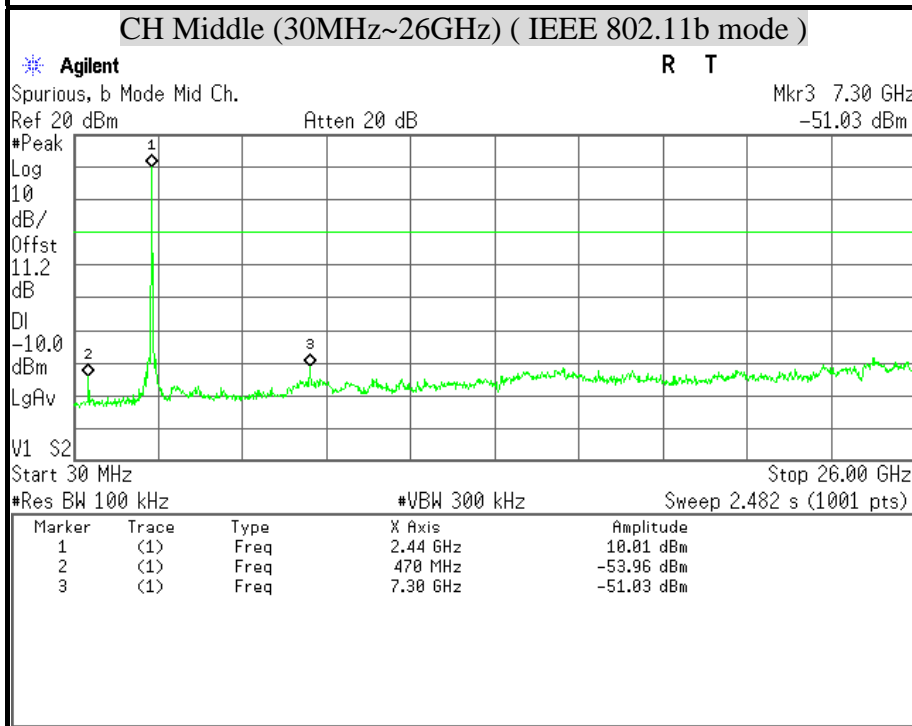
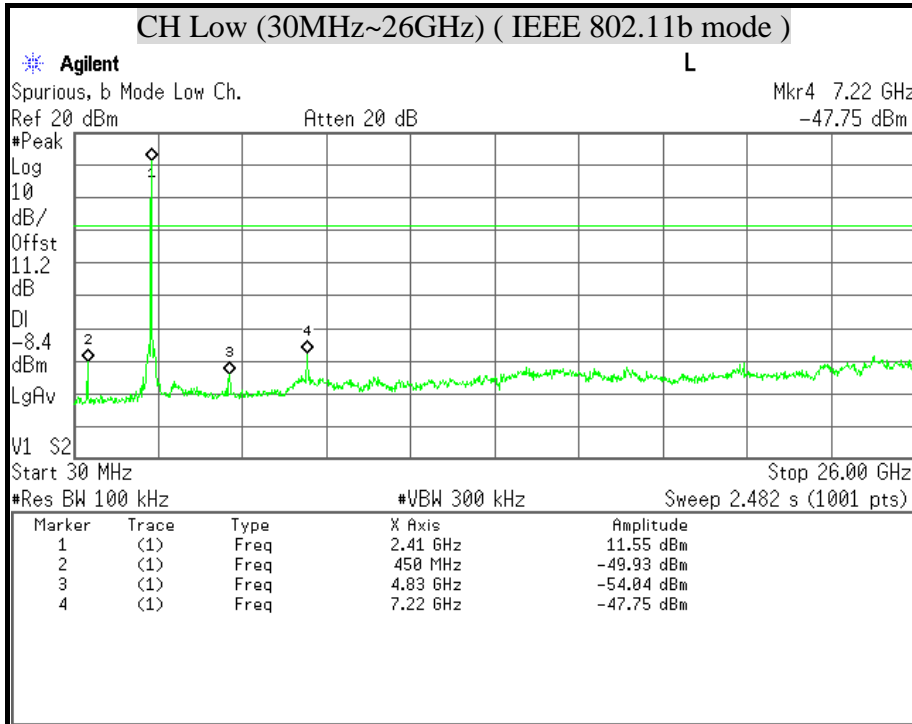

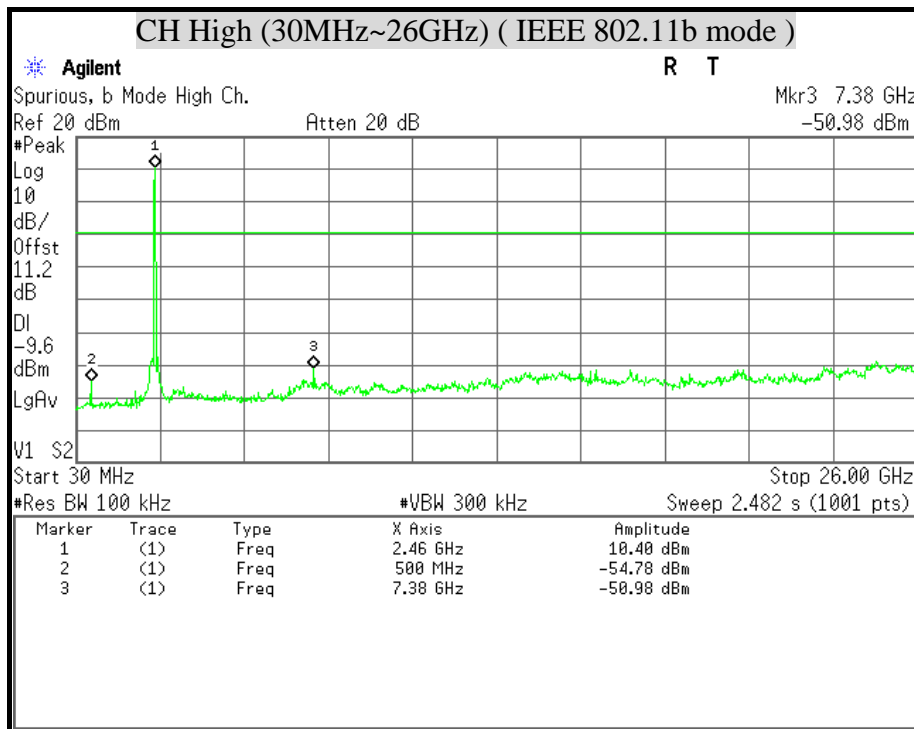



OUT-OF-BAND SPURIOUS EMISSIONS-CONDUCTED MEASUREMENT

(IEEE 802.11g mode)

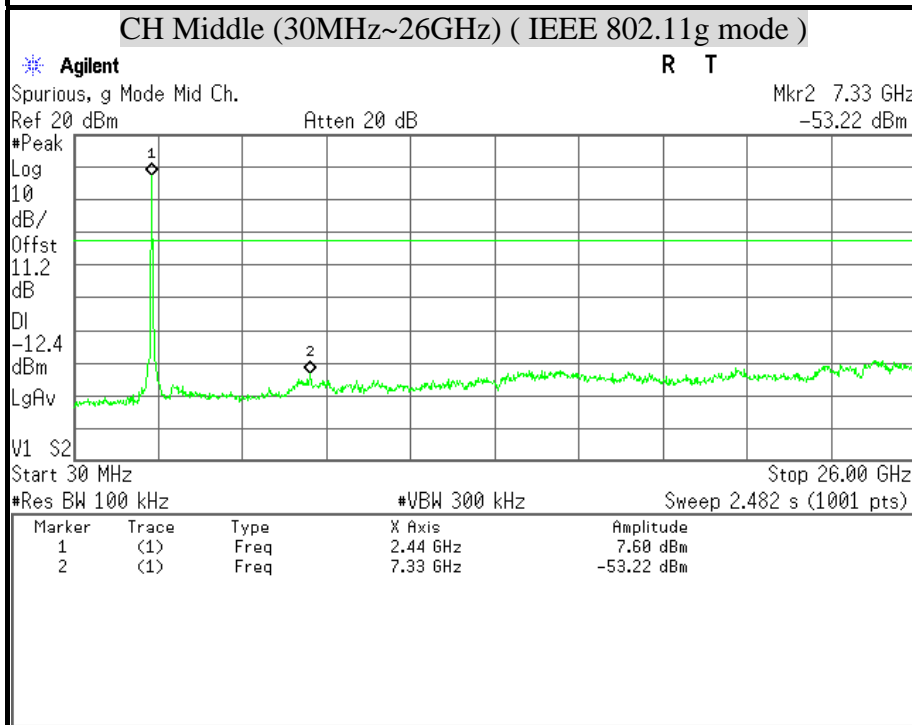
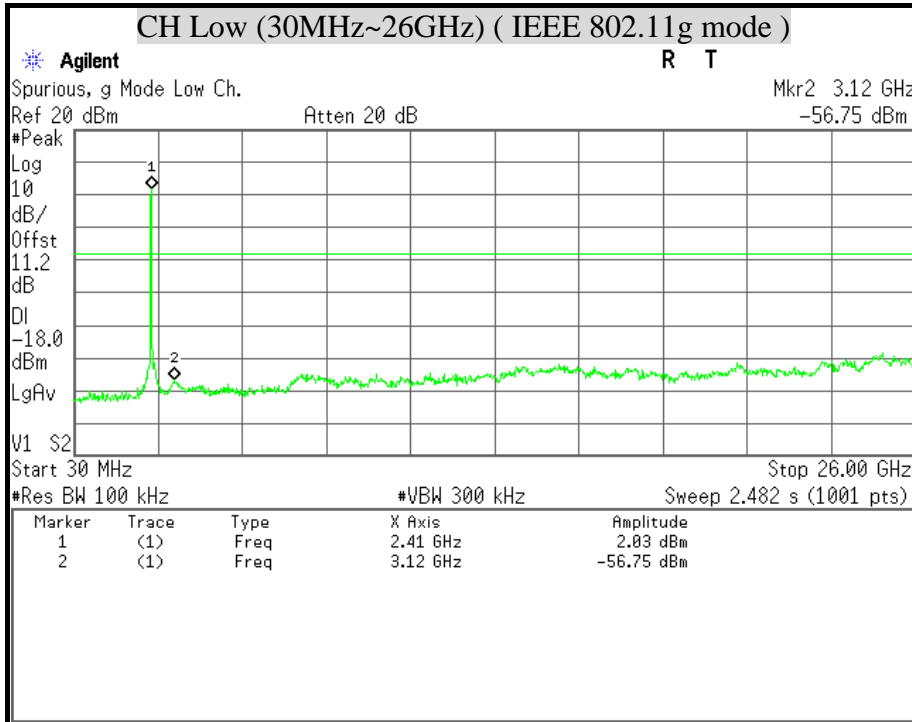

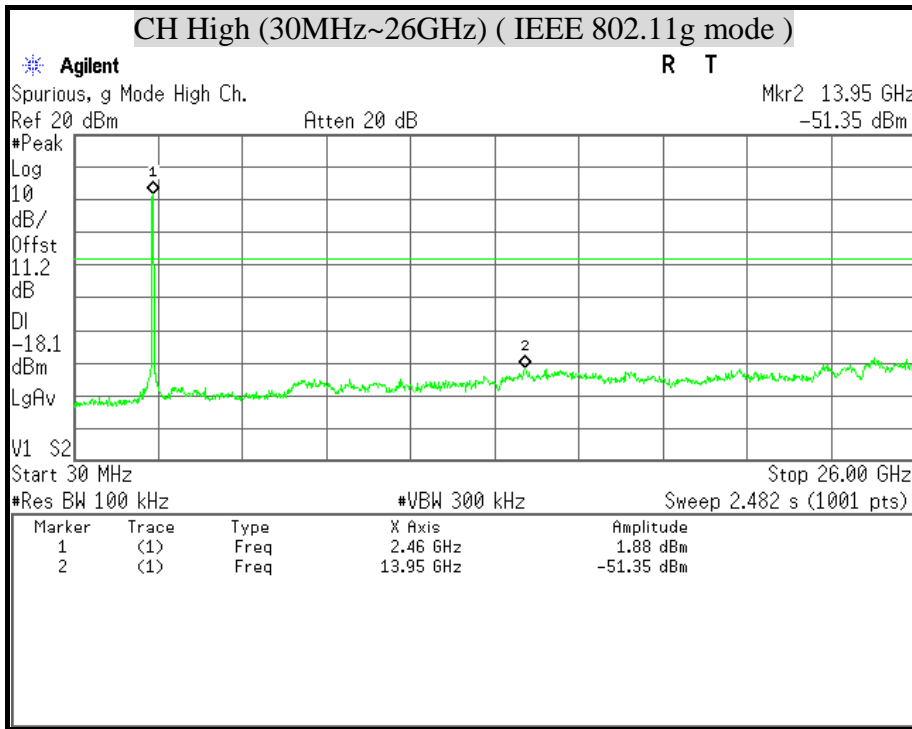



OUT-OF-BAND SPURIOUS EMISSIONS-CONDUCTED MEASUREMENT

(IEEE 802.11n HT20 mode)

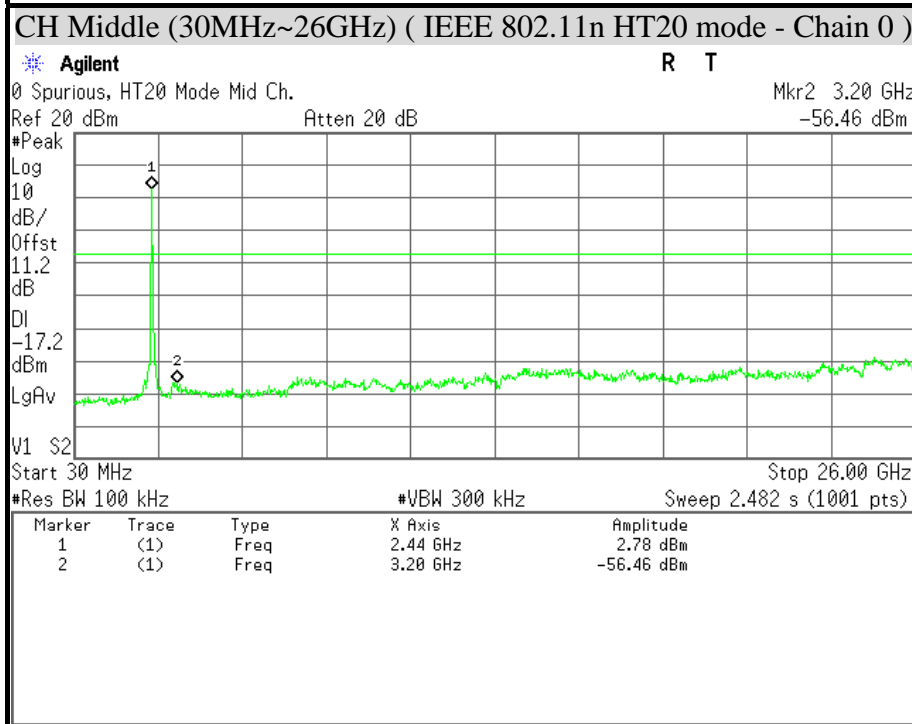
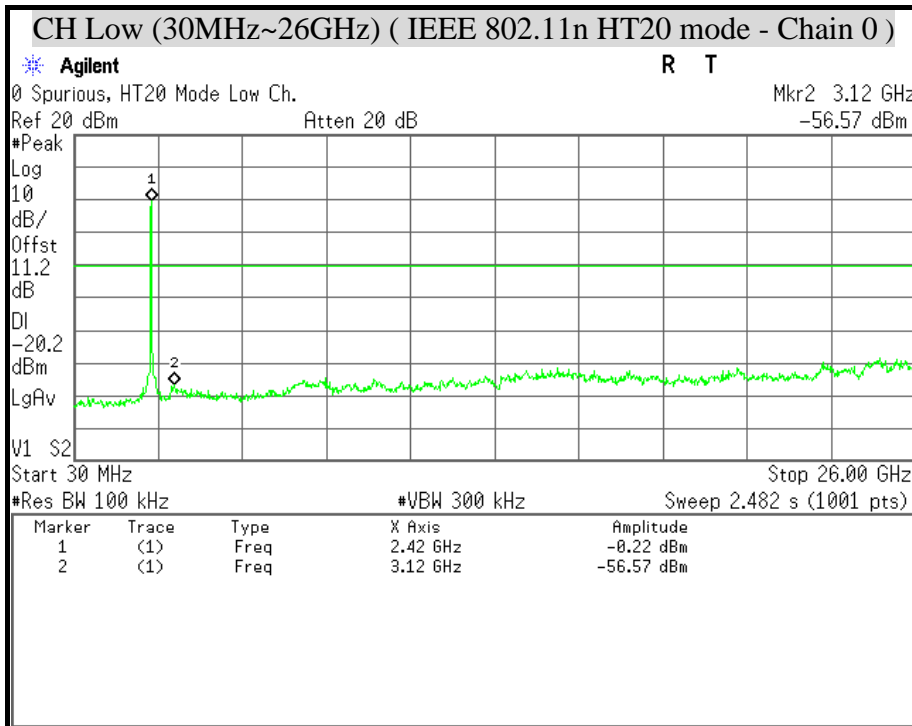

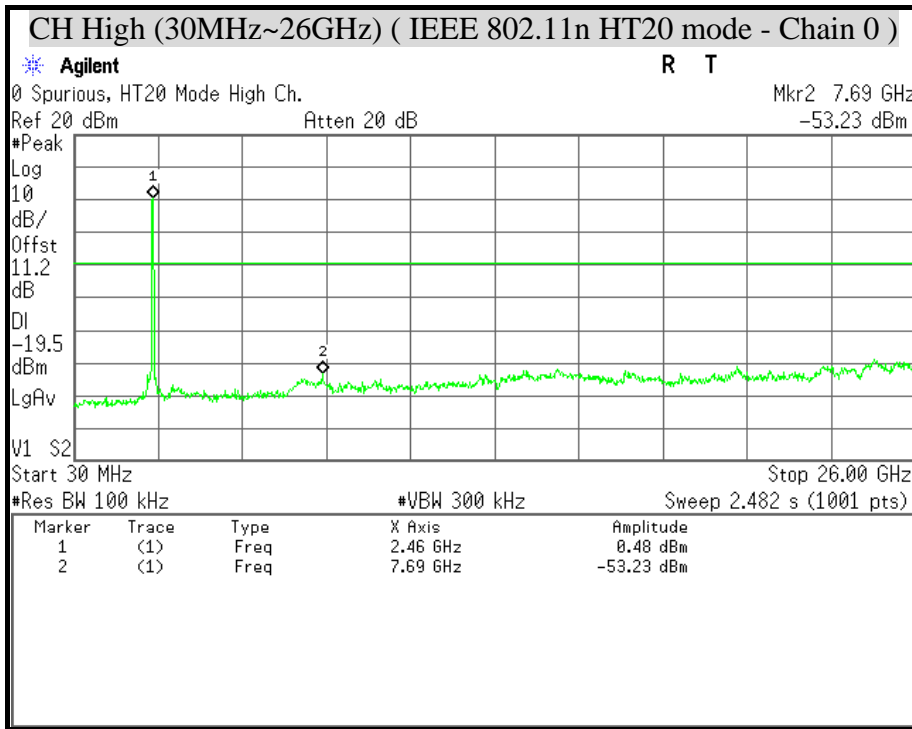

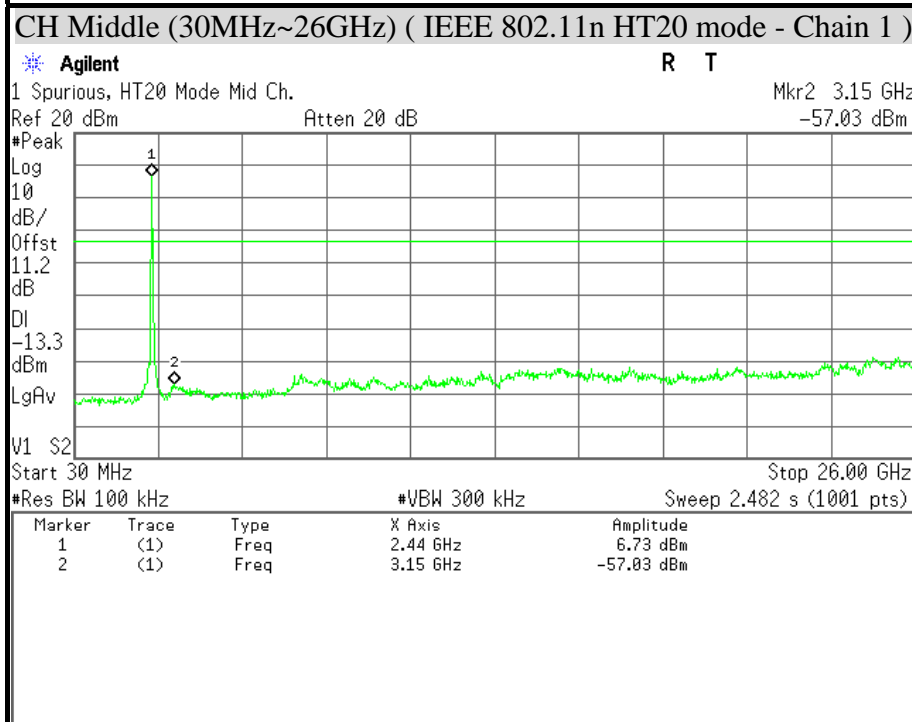
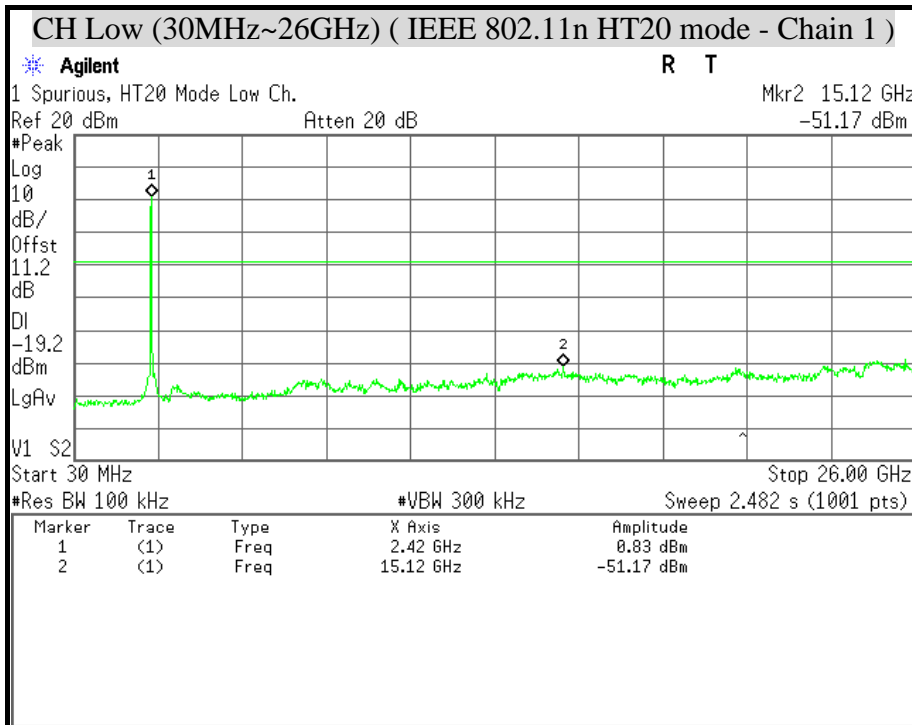

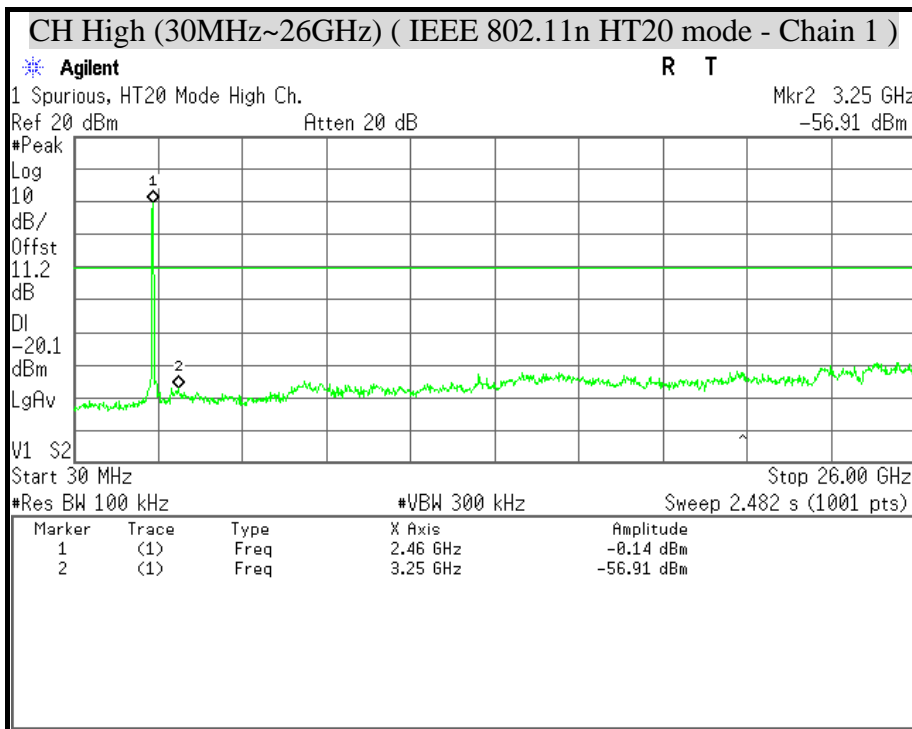



OUT-OF-BAND SPURIOUS EMISSIONS-CONDUCTED MEASUREMENT

(IEEE 802.11n HT20 Combined mode)

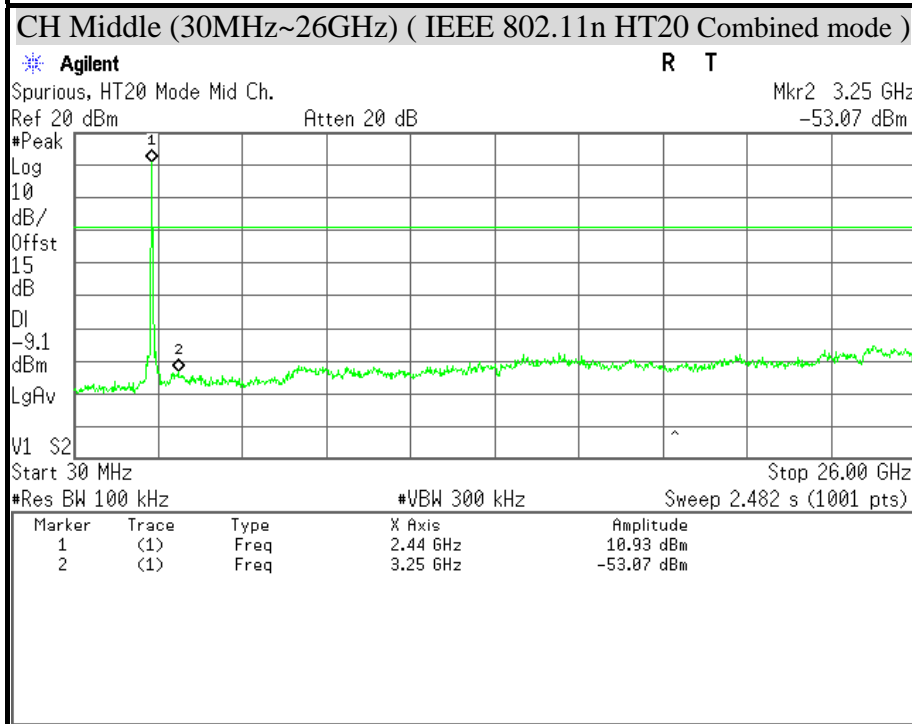
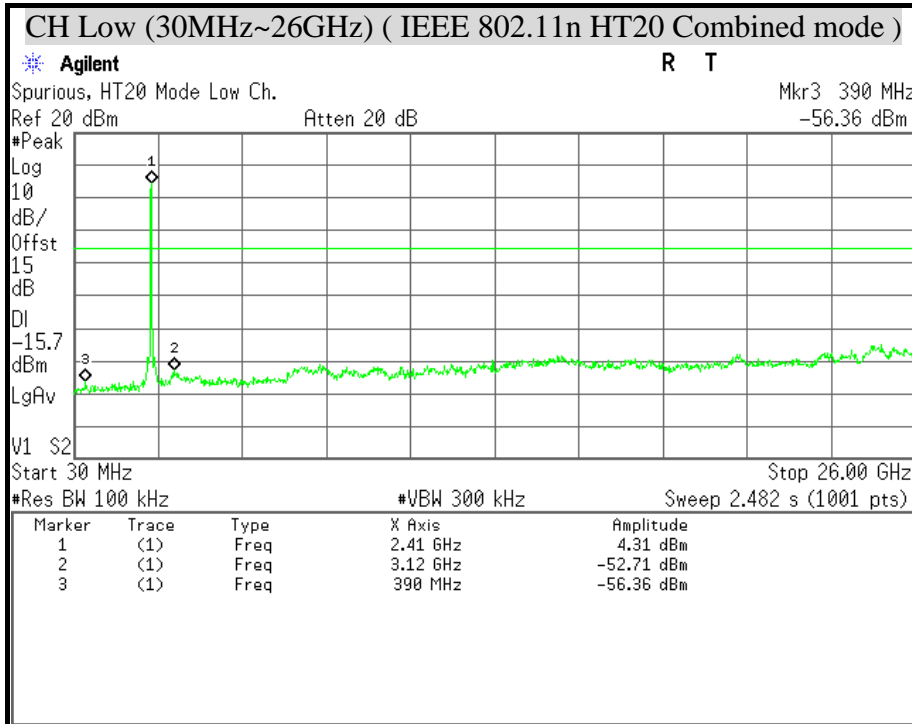

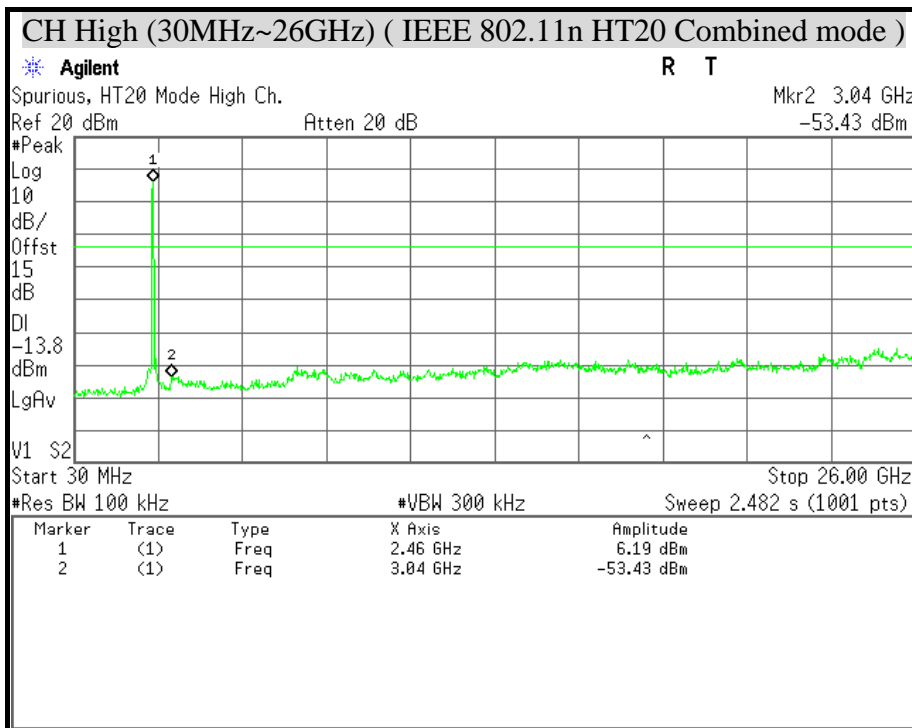



OUT-OF-BAND SPURIOUS EMISSIONS-CONDUCTED MEASUREMENT

(IEEE 802.11n HT40 mode)

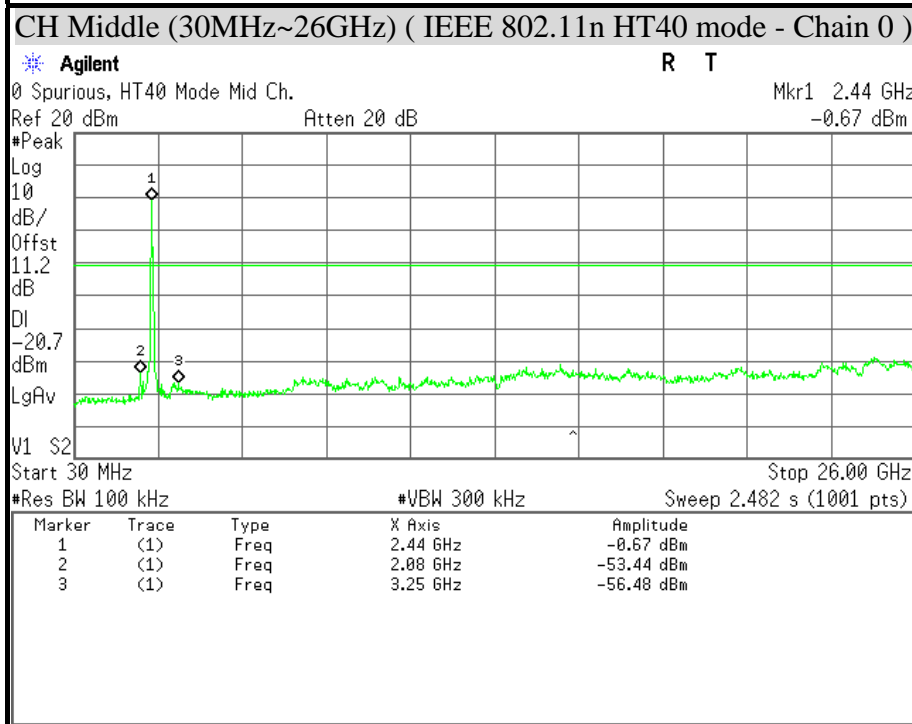
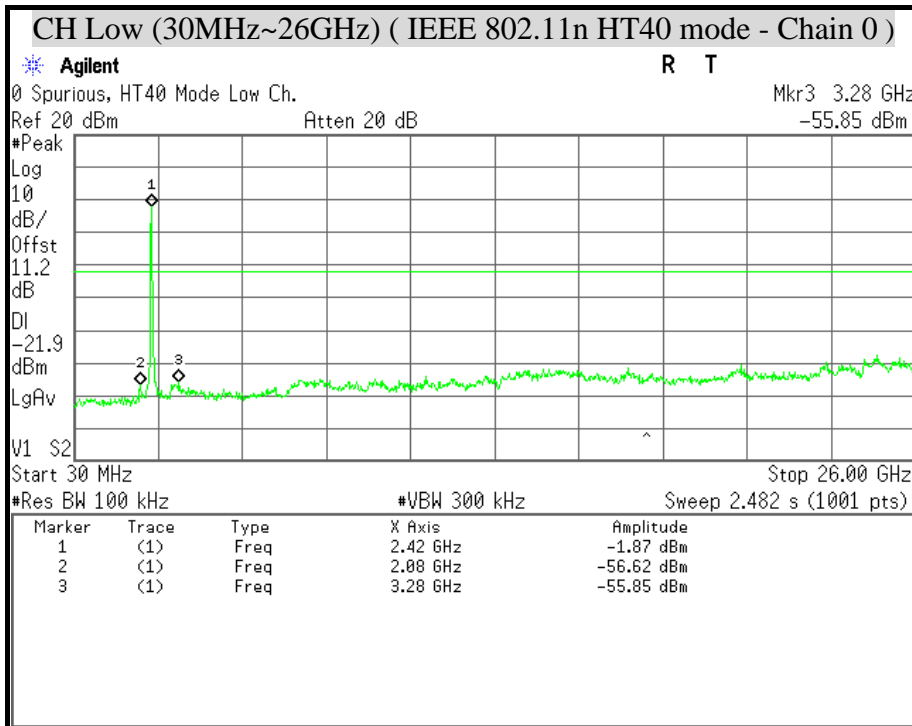

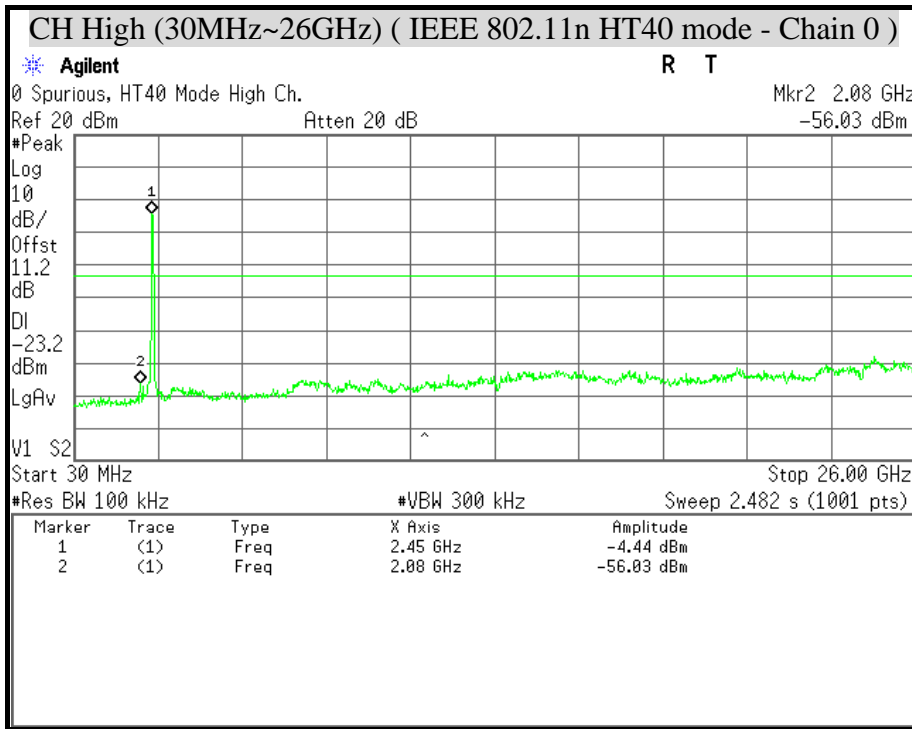

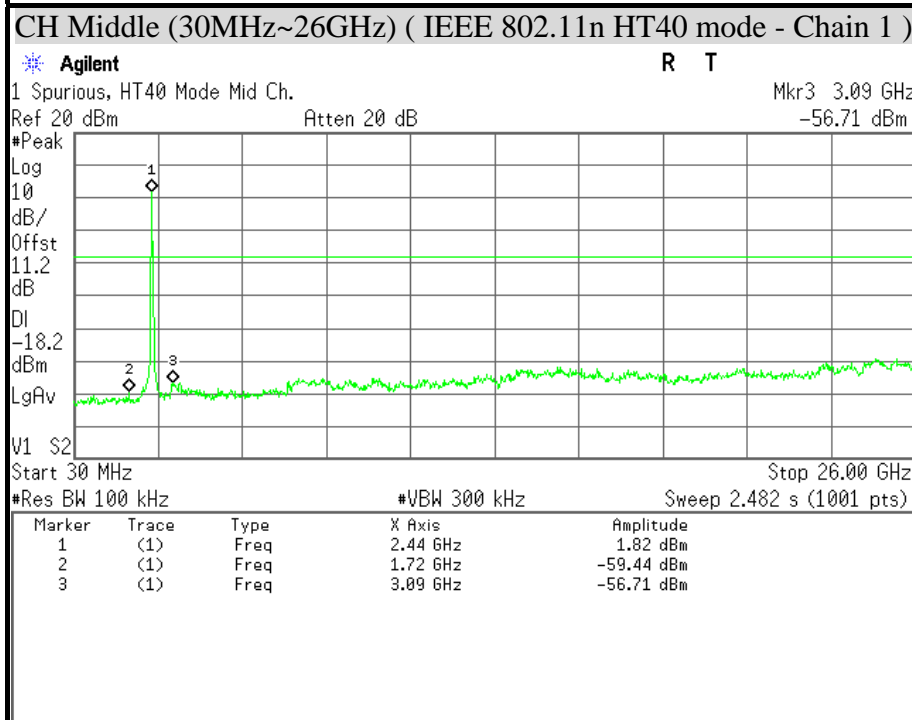
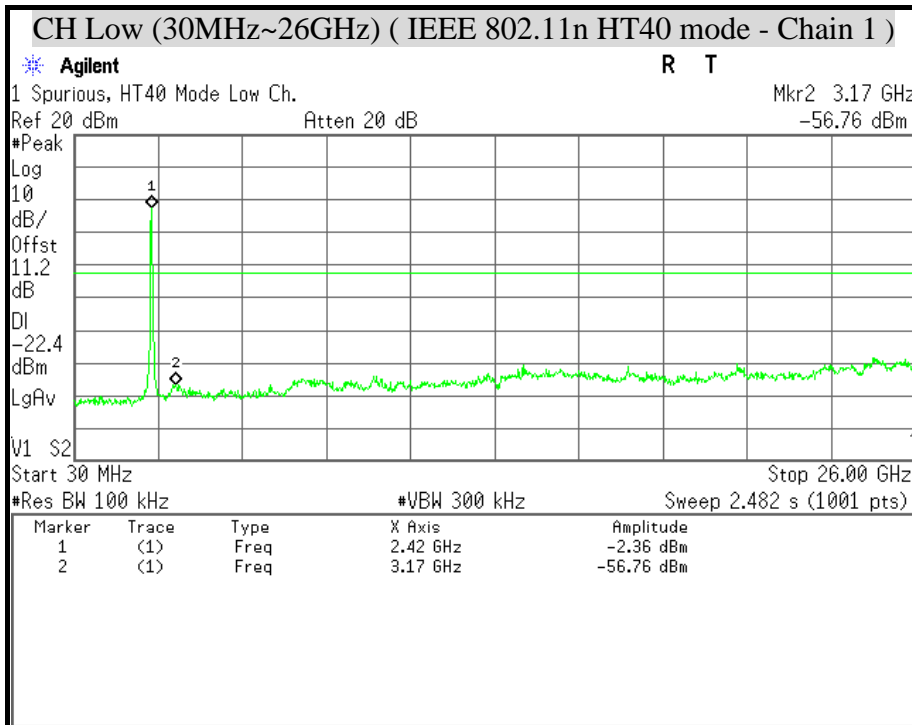

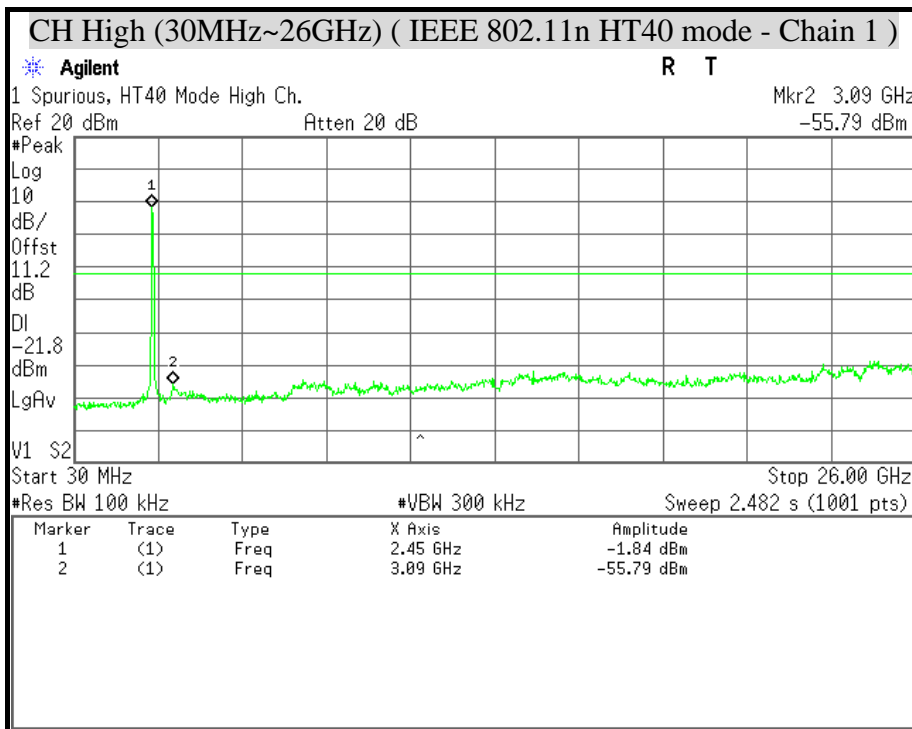



OUT-OF-BAND SPURIOUS EMISSIONS-CONDUCTED MEASUREMENT

(IEEE 802.11n HT40 Combined mode)

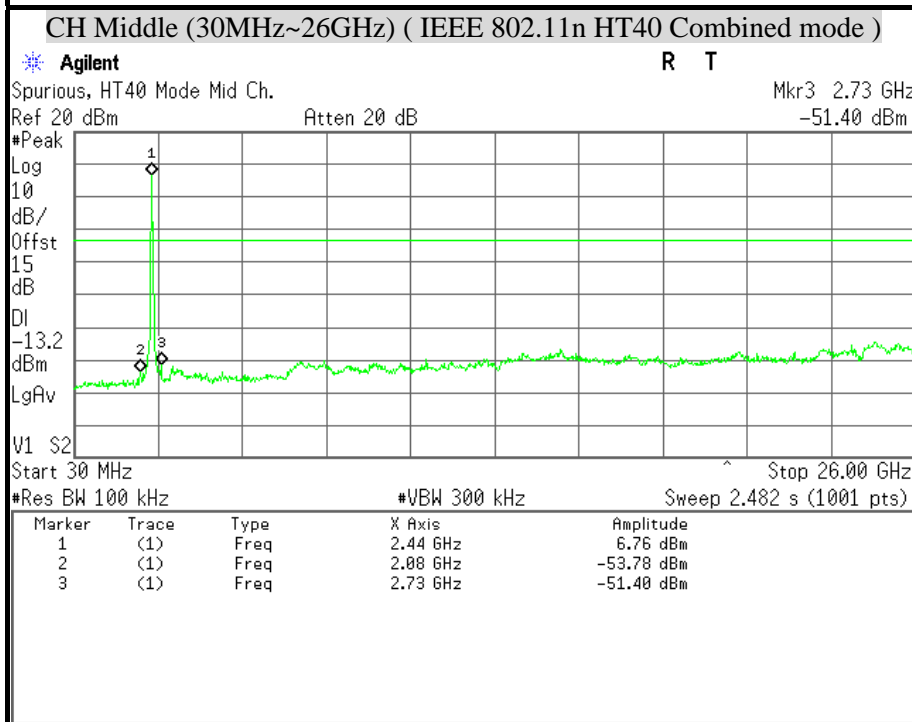
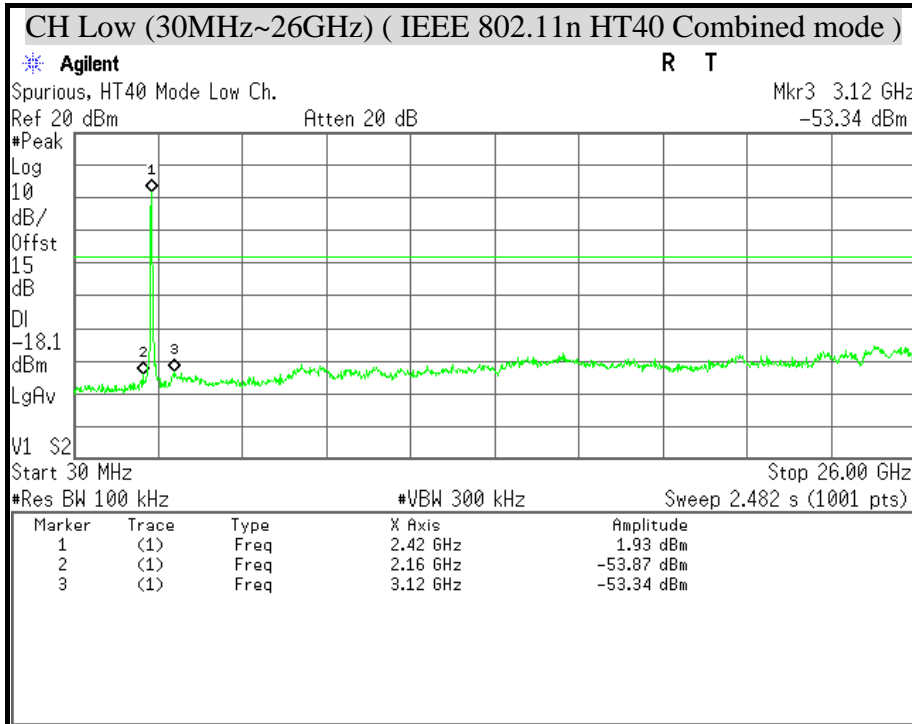

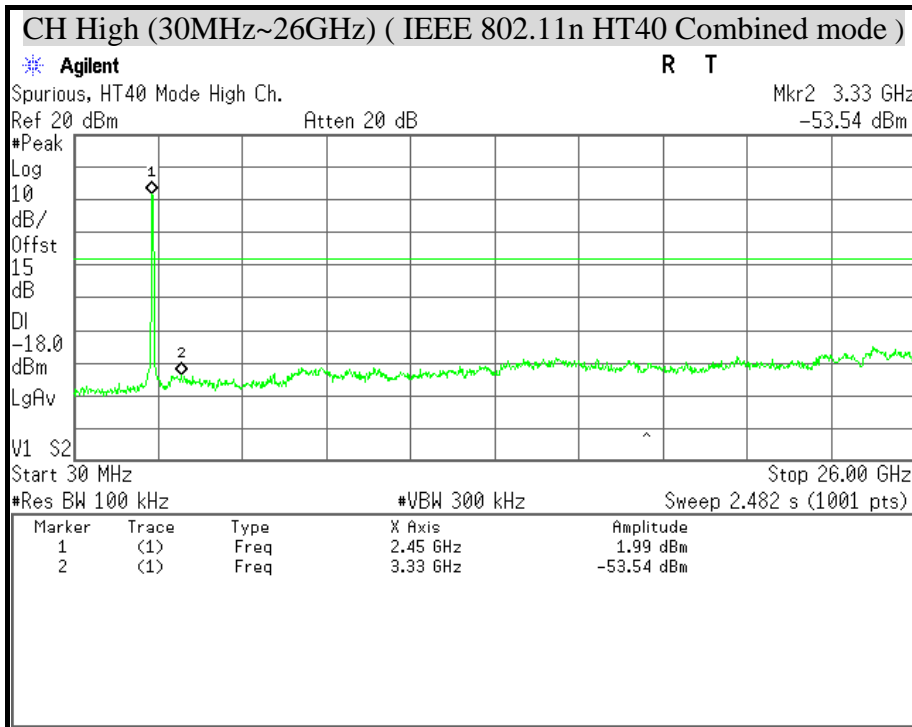



8.8 RADIATED EMISSIONS

8.8.1 TRANSMITTER RADIATED SUPURIOUS EMSSIONS

LIMITS

§ 15.205 (a) Except as shown in paragraph (d) of this section, only spurious emissions are permitted in any of the frequency bands listed below:

MHz	MHz	MHz	GHz
0.090 - 0.110	16.42 - 16.423	399.9 - 410	4.5 - 5.15
¹ 0.495 - 0.505	16.69475 - 16.69525	608 - 614	5.35 - 5.46
2.1735 - 2.1905	16.80425 - 16.80475	960 - 1240	7.25 - 7.75
4.125 - 4.128	25.5 - 25.67	1300 - 1427	8.025 - 8.5
4.17725 - 4.17775	37.5 - 38.25	1435 - 1626.5	9.0 - 9.2
4.20725 - 4.20775	73 - 74.6	1645.5 - 1646.5	9.3 - 9.5
6.215 - 6.218	74.8 - 75.2	1660 - 1710	10.6 - 12.7
6.26775 - 6.26825	108 - 121.94	1718.8 - 1722.2	13.25 - 13.4
6.31175 - 6.31225	123 - 138	2200 - 2300	14.47 - 14.5
8.291 - 8.294	149.9 - 150.05	2310 - 2390	15.35 - 16.2
8.362 - 8.366	156.52475 - 156.52525	2483.5 - 2500	17.7 - 21.4
8.37625 - 8.38675	156.7 - 156.9	2655 - 2900	22.01 - 23.12
8.41425 - 8.41475	162.0125 - 167.17	3260 - 3267	23.6 - 24.0
12.29 - 12.293	167.72 - 173.2	3332 - 3339	31.2 - 31.8
12.51975 - 12.52025	240 - 285	3345.8 - 3338	36.43 - 36.5
12.57675 - 12.57725	322 - 335.4	3600 - 4400	(²)
13.36 - 13.41			

¹ Until February 1, 1999, this restricted band shall be 0.490-0.510 MHz.

² Above 38.6

§ 15.205 (b) Except as provided in paragraphs (d) and (e), the field strength of emissions appearing within these frequency bands shall not exceed the limits shown in Section 15.209. At frequencies equal to or less than 1000 MHz, compliance with the limits in Section 15.209 shall be demonstrated using measurement instrumentation employing a CISPR quasi-peak detector. Above 1000 MHz, compliance with the emission limits in Section 15.209 shall be demonstrated based on the average value of the measured emissions. The provisions in Section 15.35 apply to these measurements.



§ 15.209 (a) Except as provided elsewhere in this Subpart, the emissions from an intentional radiator shall not exceed the field strength levels specified in the following table :

Frequency (MHz)	Field Strength (microvolts/meter)	Measurement Distance (meters)
30 - 88	100 **	3
88 - 216	150 **	3
216 - 960	200 **	3
Above 960	500	3

** Except as provided in paragraph (g), fundamental emissions from intentional radiators operating under this Section shall not be located in the frequency bands 54-72 MHz, 76-88 MHz, 174-216 MHz or 470-806 MHz, However, operation within these frequency bands is permitted under other sections of this Part, e-g, Sections 15.231 and 15.241.

§ 15.209 (b) In the emission table above, the tighter limit applies at the band edges.

TEST EQUIPMENT

Name of Equipment	Manufacturer	Model	Serial Number	Calibration Due
SPECTRUM ANALYZER	AGILENT	E4446A	MY46180323	06/09/2010
EMI TEST RECEIVER	R & S	ESCI	100221	05/17/2010
BILOG ANTENNA	SCHWARZBECK	VULB9168	9168_249	09/17/2009
Double-Ridged Waveguide Horn	ETS LINDGREN	3117	00078732	06/30/2010
PRE-AMPLIFIER	EM	EM30265	07032611	07/14/2010
Notch Filters Band Reject	Micro-Tronics	BRM50702-01	009	N.C.R.
RF COAXIAL CABLE	HUBERSUHNER	SUCOFLEX 104PEA	SN31350	07/21/2010
LOOP ANTENNA	EMCO	6502	2356	05/28/2010

Remark: 1. Each piece of equipment is scheduled for calibration once a year.

2. N.C.R = No Calibration Request.

TEST SETUP

The diagram below shows the test setup that is utilized to make the measurements for emission from below 1GHz.

9kHz ~ 30MHz

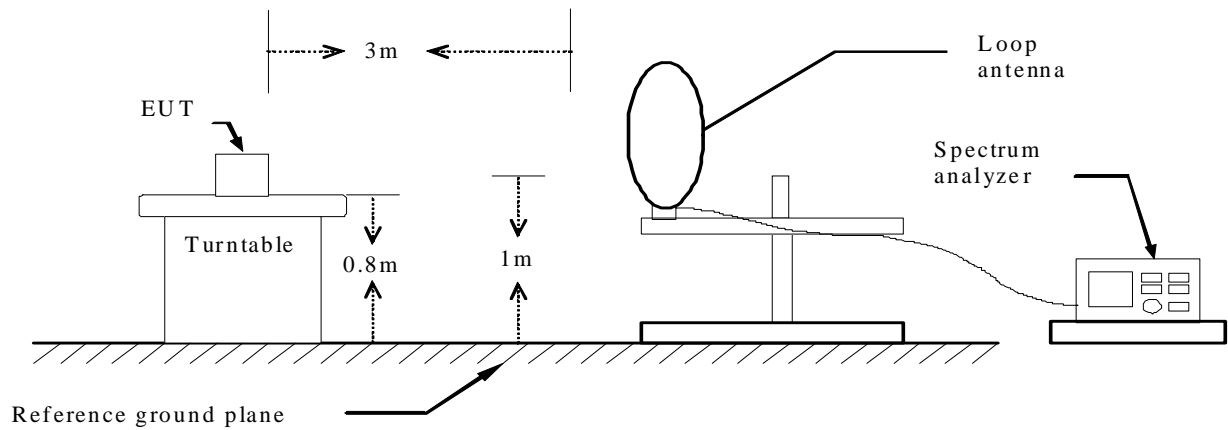

30MHz ~ 1GHz

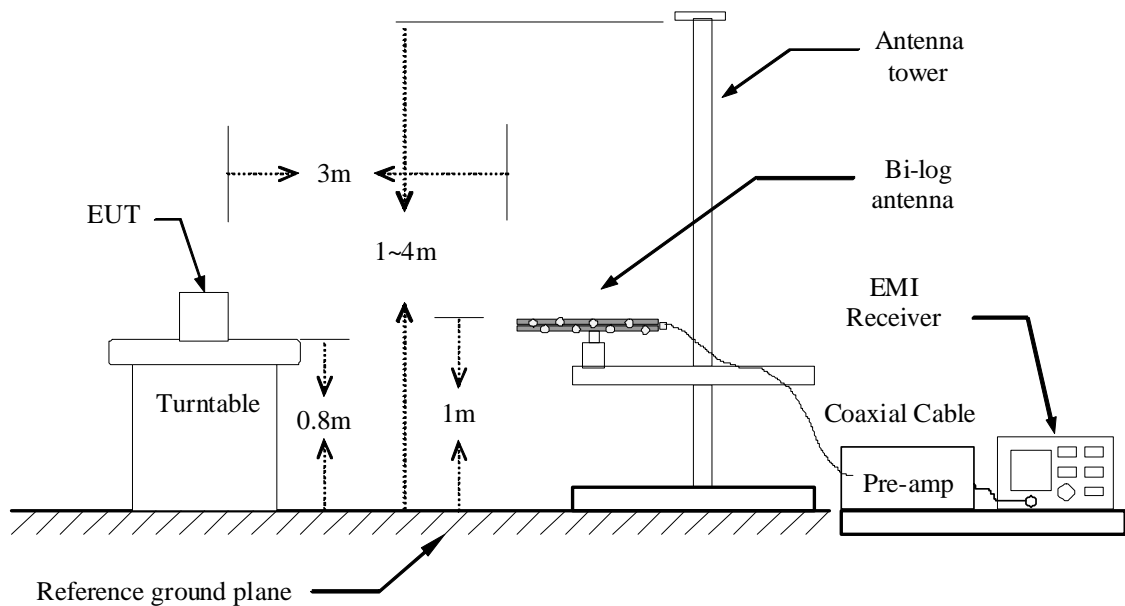

The diagram below shows the test setup that is utilized to make the measurements for emission above 1GHz.

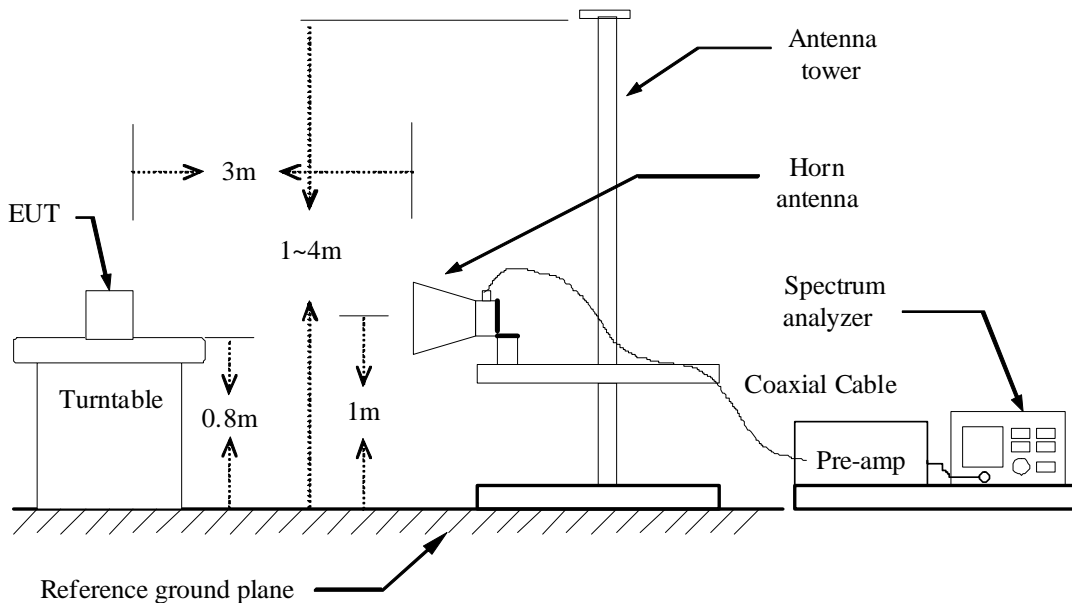

TEST PROCEDURE

- a. The EUT was placed on the top of a rotating table 0.8 meters above the ground at a 10 meter open area test site. The table was rotated 360 degrees to determine the position of the highest radiation.
- b. While measuring the radiated emission below 1GHz, the EUT was set 3 meters away from the interference-receiving antenna, which was mounted on the top of a variable-height antenna tower. While measuring the radiated emission above 1GHz, the EUT was set 3 meters away from the interference-receiving antenna
- c. The antenna is a broadband antenna, and its height is varied from one meter to four meters above the ground to determine the maximum value of the field strength. Both horizontal and vertical polarization of the antenna are set to make the measurement.
- d. For each suspected emission, the EUT was arranged to its worst case and then the antenna was tuned to heights from 1 meter to 4 meters and the table was turned from 0 degrees to 360 degrees to find the maximum reading.
- e. The test-receiver system was set to Peak Detect Function and Specified Bandwidth with Maximum Hold Mode.
- f. If the emission level of the EUT in peak mode was 10 dB lower than the limit specified, then testing could be stopped and the peak values of the EUT would be reported. Otherwise the emissions that did not have 10 dB margin would be re-tested one by one using peak, quasi-peak or average method as specified and then reported in a data sheet.

Note :

1. The resolution bandwidth and video bandwidth of test receiver/spectrum analyzer is 120 KHz for Peak detection (PK) and Quasi-peak detection (QP) at frequency below 1GHz.
2. The resolution bandwidth and video bandwidth of test receiver/spectrum analyzer is 1 MHz for Peak detection and frequency above 1GHz.
3. The resolution bandwidth of test receiver/spectrum analyzer is 1 MHz and the video bandwidth is 10 Hz for Average detection (AV) at frequency above 1GHz.

**8.8.2 WORST-CASE RADIATED EMISSION BELOW 1 GHz****BELOW 1 GHz (9kHz ~ 30MHz)**

No emission found between lowest internal used/generated frequency to 30MHz.

BELOW 1 GHz (30MHz ~ 1GHz)

Product Name	Wireless N Router	Test Date	2009/07/28
Model	DIR-605	Test By	Rueyyan Lin
Test Mode	Normal operating (worst-case)	TEMP & Humidity	25.9°C, 54%

Horizontal						
Frequency (MHz)	Reading (dBμV)	Correction Factor (dB/m)	Result (dBμV/m)	Limit (dBμV/m)	Margin (dB)	Remark
149.31	70.60	-31.78	38.82	43.50	-4.68	QP
249.22	72.14	-31.66	40.48	46.00	-5.52	Peak
303.54	69.65	-29.11	40.54	46.00	-5.46	Peak
407.33	70.16	-27.38	42.78	46.00	-3.22	Peak
465.53	64.23	-26.39	37.85	46.00	-8.15	Peak
533.43	57.73	-25.37	32.36	46.00	-13.64	Peak
733.25	57.83	-21.84	35.98	46.00	-10.02	Peak
Vertical						
Frequency (MHz)	Reading (dBμV)	Correction Factor (dB/m)	Result (dBμV/m)	Limit (dBμV/m)	Margin (dB)	Remark
52.31	64.30	-30.39	33.91	40.00	-6.09	QP
154.16	70.20	-31.54	38.66	43.50	-4.84	QP
266.68	70.43	-30.76	39.67	46.00	-6.33	Peak
299.66	67.53	-29.21	38.32	46.00	-7.68	Peak
350.10	62.72	-28.09	34.63	46.00	-11.37	Peak
517.91	60.30	-25.64	34.66	46.00	-11.34	Peak
900.09	51.69	-19.59	32.10	46.00	-13.90	Peak

Remark:

1. Quasi-peak test would be performed if the peak result were greater than the quasi-peak limit.
2. Data of measurement within this frequency range shown " --- " in the table above means the reading of emissions are attenuated more than 20dB below the permissible limits or the field strength is too small to be measured.
3. Correction Factor (dB/m) = Antenna Factor (dB/m) + Cable Loss (dB) – PreAmp.Gain (dB)
4. Result (dBμV/m) = Reading (dBμV) + Correction Factor (dB/m)
5. Margin (dB) = Remark result (dBμV/m) - Quasi-peak limit (dBμV/m).

**8.8.3 TRANSMITTER RADIATED EMISSION ABOVE 1 GHz**

Product Name	Wireless N Router	Test Date	2009/07/28
Model	DIR-605	Test By	Rick Lin
Test Mode	IEEE 802.11b TX (CH Low)	TEMP & Humidity	25.9°C, 54%

Horizontal									
Frequency (MHz)	Reading-PK (dBμV)	Reading-AV (dBμV)	Correction Factor (dB/m)	Result-PK (dBμV/m)	Result-AV (dBμV/m)	Limit-PK (dBμV/m)	Limit-AV (dBμV/m)	Margin (dB)	Remark
2330.00	64.71	56.23	-8.96	55.74	47.27	74.00	54.00	-6.73	AVG
2412.00	116.57	---	-8.85	107.72	---	---	---	---	Carrier
2490.00	64.46	56.78	-8.75	55.71	48.03	74.00	54.00	-5.97	AVG
4822.50	52.05	---	-4.56	47.49	---	74.00	54.00	-6.51	Peak
5767.50	51.42	---	-2.99	48.43	---	74.00	54.00	-5.57	Peak
7237.50	56.67	50.81	-0.89	55.78	49.92	74.00	54.00	-4.08	AVG
Vertical									
Frequency (MHz)	Reading-PK (dBμV)	Reading-AV (dBμV)	Correction Factor (dB/m)	Result-PK (dBμV/m)	Result-AV (dBμV/m)	Limit-PK (dBμV/m)	Limit-AV (dBμV/m)	Margin (dB)	Remark
2412.00	122.44	117.30	-8.85	113.58	108.45	---	---	---	Carrier
2490.00	70.50	61.21	-8.75	61.75	52.46	74.00	54.00	-1.54	AVG
2530.00	67.65	58.78	-8.71	58.94	50.07	74.00	54.00	-3.93	AVG
4822.50	58.82	53.01	-4.56	54.26	48.45	74.00	54.00	-5.55	AVG
5655.00	51.27	---	-3.11	48.16	---	74.00	54.00	-5.84	Peak
7237.50	57.06	51.56	-0.89	56.17	50.67	74.00	54.00	-3.33	AVG

Remark:

1. Measuring frequencies from 1 GHz to the 10th harmonic of highest fundamental frequency.
2. Average test would be performed if the peak result were greater than the average limit.
3. Data of measurement within this frequency range shown " --- " in the table above means the reading of emissions are attenuated more than 20dB below the permissible limits or the field strength is too small to be measured.
4. Measurements above show only up to 6 maximum emissions noted, or would be lesser, with " N/A " remark, if no specific emissions from the EUT are recorded (ie: margin>20dB from the applicable limit) and considered that's already beyond the background noise floor.
5. In any 100 kHz bandwidth outside the frequency band in which the spread spectrum or digitally modulated intentional radiator is operating, the radio frequency power that is produced by the intentional radiator shall be at least 20 dB below that in the 100 kHz bandwidth within the band that contains the highest level of the desired power, based on either an RF conducted or a radiated measurement, provided the transmitter demonstrates compliance with the peak conducted power limits. If the transmitter complies with the conducted power limits based on the use of RMS averaging over a time interval, as permitted under paragraph (b)(3) of this section, the attenuation required under this paragraph shall be 30 dB instead of 20 dB.
6. Result = Reading + Correction Factor
Margin = Result - Limit
Remark Peak = Result(PK) - Limit(AV)
Remark AVG = Result(AV) - Limit(AV)



Product Name	Wireless N Router	Test Date	2009/07/28
Model	DIR-605	Test By	Rick Lin
Test Mode	IEEE 802.11b TX (CH Middle)	TEMP & Humidity	25.9°C, 54%

Horizontal									
Frequency (MHz)	Reading-PK (dBμV)	Reading-AV (dBμV)	Correction Factor (dB/m)	Result-PK (dBμV/m)	Result-AV (dBμV/m)	Limit-PK (dBμV/m)	Limit-AV (dBμV/m)	Margin (dB)	Remark
2436.00	115.14	---	-8.82	106.32	---	---	---	---	Carrier
4590.00	51.41	---	-5.16	46.26	---	74.00	54.00	-7.74	Peak
5685.00	51.07	---	-3.08	47.99	---	74.00	54.00	-6.01	Peak
6157.50	50.50	---	-2.55	47.94	---	74.00	54.00	-6.06	Peak
6682.50	50.93	---	-1.77	49.16	---	74.00	54.00	-4.84	Peak
7312.50	55.39	47.97	-0.83	54.56	47.14	74.00	54.00	-6.86	AVG
Vertical									
Frequency (MHz)	Reading-PK (dBμV)	Reading-AV (dBμV)	Correction Factor (dB/m)	Result-PK (dBμV/m)	Result-AV (dBμV/m)	Limit-PK (dBμV/m)	Limit-AV (dBμV/m)	Margin (dB)	Remark
2438.00	119.95	116.29	-8.82	111.13	107.47	---	---	---	Carrier
2516.00	71.21	61.54	-8.72	62.49	52.82	74.00	54.00	-1.18	AVG
2560.00	71.65	61.12	-8.69	62.96	52.43	74.00	54.00	-1.57	AVG
4875.00	53.77	---	-4.42	49.35	---	74.00	54.00	-4.65	Peak
5662.50	51.34	---	-3.10	48.24	---	74.00	54.00	-5.76	Peak
7312.50	58.13	52.35	-0.83	57.30	51.52	74.00	54.00	-2.48	AVG
8002.50	49.28	---	0.40	49.68	---	74.00	54.00	-4.32	Peak

Remark:

1. Measuring frequencies from 1 GHz to the 10th harmonic of highest fundamental frequency.
2. Average test would be performed if the peak result were greater than the average limit.
3. Data of measurement within this frequency range shown " --- " in the table above means the reading of emissions are attenuated more than 20dB below the permissible limits or the field strength is too small to be measured.
4. Measurements above show only up to 6 maximum emissions noted, or would be lesser, with " N/A " remark, if no specific emissions from the EUT are recorded (ie: margin>20dB from the applicable limit) and considered that's already beyond the background noise floor.
5. In any 100 kHz bandwidth outside the frequency band in which the spread spectrum or digitally modulated intentional radiator is operating, the radio frequency power that is produced by the intentional radiator shall be at least 20 dB below that in the 100 kHz bandwidth within the band that contains the highest level of the desired power, based on either an RF conducted or a radiated measurement, provided the transmitter demonstrates compliance with the peak conducted power limits. If the transmitter complies with the conducted power limits based on the use of RMS averaging over a time interval, as permitted under paragraph (b)(3) of this section, the attenuation required under this paragraph shall be 30 dB instead of 20 dB.
6. Result = Reading + Correction Factor
Margin = Result - Limit
Remark Peak = Result(PK) - Limit(AV)
Remark AVG = Result(AV) - Limit(AV)



Product Name	Wireless N Router	Test Date	2009/07/28
Model	DIR-605	Test By	Rick Lin
Test Mode	IEEE 802.11b TX (CH High)	TEMP & Humidity	25.9°C, 54%

Horizontal									
Frequency (MHz)	Reading-PK (dBμV)	Reading-AV (dBμV)	Correction Factor (dB/m)	Result-PK (dBμV/m)	Result-AV (dBμV/m)	Limit-PK (dBμV/m)	Limit-AV (dBμV/m)	Margin (dB)	Remark
2384.00	64.58	56.74	-8.89	55.68	47.85	74.00	54.00	-6.15	AVG
2462.00	107.42	103.67	-8.79	98.63	94.88	---	---	---	Carrier
2542.00	63.76	56.61	-8.70	55.05	47.91	74.00	54.00	-6.09	AVG
4552.50	50.84	---	-4.20	46.63	---	74.00	54.00	-7.37	Peak
4927.50	51.33	---	-3.98	47.35	---	74.00	54.00	-6.65	Peak
5752.50	50.26	---	-1.64	48.61	---	74.00	54.00	-5.39	Peak
7387.50	51.02	42.40	1.85	52.87	44.25	74.00	54.00	-9.75	AVG
Vertical									
Frequency (MHz)	Reading-PK (dBμV)	Reading-AV (dBμV)	Correction Factor (dB/m)	Result-PK (dBμV/m)	Result-AV (dBμV/m)	Limit-PK (dBμV/m)	Limit-AV (dBμV/m)	Margin (dB)	Remark
2462.00	115.68	112.45	-8.79	106.89	103.66	---	---	---	Carrier
2542.00	69.23	59.07	-8.70	60.53	50.37	74.00	54.00	-3.63	AVG
2578.00	69.89	58.77	-8.68	61.21	50.09	74.00	54.00	-3.91	AVG
4087.50	51.99	---	-6.03	45.96	---	74.00	54.00	-8.04	Peak
4920.00	53.41	---	-3.98	49.43	---	74.00	54.00	-4.57	Peak
6045.00	50.42	---	-0.67	49.75	---	74.00	54.00	-4.25	Peak
7387.50	56.32	49.41	1.85	58.17	51.26	74.00	54.00	-2.74	AVG

Remark:

1. Measuring frequencies from 1 GHz to the 10th harmonic of highest fundamental frequency.
2. Average test would be performed if the peak result were greater than the average limit.
3. Data of measurement within this frequency range shown " --- " in the table above means the reading of emissions are attenuated more than 20dB below the permissible limits or the field strength is too small to be measured.
4. Measurements above show only up to 6 maximum emissions noted, or would be lesser, with " N/A " remark, if no specific emissions from the EUT are recorded (ie: margin>20dB from the applicable limit) and considered that's already beyond the background noise floor.
5. In any 100 kHz bandwidth outside the frequency band in which the spread spectrum or digitally modulated intentional radiator is operating, the radio frequency power that is produced by the intentional radiator shall be at least 20 dB below that in the 100 kHz bandwidth within the band that contains the highest level of the desired power, based on either an RF conducted or a radiated measurement, provided the transmitter demonstrates compliance with the peak conducted power limits. If the transmitter complies with the conducted power limits based on the use of RMS averaging over a time interval, as permitted under paragraph (b)(3) of this section, the attenuation required under this paragraph shall be 30 dB instead of 20 dB.
6. Result = Reading + Correction Factor
Margin = Result - Limit
Remark Peak = Result(PK) - Limit(AV)
Remark AVG = Result(AV) - Limit(AV)



Product Name	Wireless N Router	Test Date	2009/07/28
Model	DIR-605	Test By	Rick Lin
Test Mode	IEEE 802.11g TX (CH Low)	TEMP & Humidity	25.9°C, 54%

Horizontal									
Frequency (MHz)	Reading-PK (dBμV)	Reading-AV (dBμV)	Correction Factor (dB/m)	Result-PK (dBμV/m)	Result-AV (dBμV/m)	Limit-PK (dBμV/m)	Limit-AV (dBμV/m)	Margin (dB)	Remark
2412.00	111.16	---	-8.85	102.30	---	---	---	---	Carrier
4995.00	52.36	---	-4.12	48.25	---	74.00	54.00	-5.75	Peak
5767.50	51.55	---	-2.99	48.57	---	74.00	54.00	-5.43	Peak
7237.50	46.72	---	-0.89	45.83	---	74.00	54.00	-8.17	Peak
8265.00	49.19	---	0.73	49.92	---	74.00	54.00	-4.08	Peak
9645.00	46.92	---	2.51	49.43	---	74.00	54.00	-4.57	Peak
Vertical									
Frequency (MHz)	Reading-PK (dBμV)	Reading-AV (dBμV)	Correction Factor (dB/m)	Result-PK (dBμV/m)	Result-AV (dBμV/m)	Limit-PK (dBμV/m)	Limit-AV (dBμV/m)	Margin (dB)	Remark
2412.00	118.75	99.81	-8.85	109.90	90.96	---	---	---	Carrier
2492.00	67.15	53.86	-8.75	58.40	45.11	74.00	54.00	-8.89	AVG
2532.00	68.79	54.58	-8.71	60.08	45.87	74.00	54.00	-8.13	AVG
3352.50	54.44	---	-7.59	46.85	---	74.00	54.00	-7.15	Peak
5002.50	52.47	---	-4.10	48.37	---	74.00	54.00	-5.63	Peak
7237.50	50.85	---	-0.89	49.97	---	74.00	54.00	-4.03	Peak

Remark:

1. Measuring frequencies from 1 GHz to the 10th harmonic of highest fundamental frequency.
2. Average test would be performed if the peak result were greater than the average limit.
3. Data of measurement within this frequency range shown " --- " in the table above means the reading of emissions are attenuated more than 20dB below the permissible limits or the field strength is too small to be measured.
4. Measurements above show only up to 6 maximum emissions noted, or would be lesser, with " N/A " remark, if no specific emissions from the EUT are recorded (ie: margin>20dB from the applicable limit) and considered that's already beyond the background noise floor.
5. In any 100 kHz bandwidth outside the frequency band in which the spread spectrum or digitally modulated intentional radiator is operating, the radio frequency power that is produced by the intentional radiator shall be at least 20 dB below that in the 100 kHz bandwidth within the band that contains the highest level of the desired power, based on either an RF conducted or a radiated measurement, provided the transmitter demonstrates compliance with the peak conducted power limits. If the transmitter complies with the conducted power limits based on the use of RMS averaging over a time interval, as permitted under paragraph (b)(3) of this section, the attenuation required under this paragraph shall be 30 dB instead of 20 dB.
6. Result = Reading + Correction Factor
Margin = Result - Limit
Remark Peak = Result(PK) - Limit(AV)
Remark AVG = Result(AV) - Limit(AV)



Product Name	Wireless N Router	Test Date	2009/07/28
Model	DIR-605	Test By	Rick Lin
Test Mode	IEEE 802.11g TX (CH Middle)	TEMP & Humidity	25.9°C, 54%

Horizontal									
Frequency (MHz)	Reading-PK (dBμV)	Reading-AV (dBμV)	Correction Factor (dB/m)	Result-PK (dBμV/m)	Result-AV (dBμV/m)	Limit-PK (dBμV/m)	Limit-AV (dBμV/m)	Margin (dB)	Remark
2438.00	116.11	---	-8.82	107.29	---	---	---	---	Carrier
4875.00	51.23	---	-4.42	46.81	---	74.00	54.00	-7.19	Peak
6495.00	48.74	---	-2.19	46.55	---	74.00	54.00	-7.45	Peak
7312.50	55.96	40.59	-0.83	55.13	39.76	74.00	54.00	-14.24	AVG
9750.00	45.84	---	2.66	48.50	---	74.00	54.00	-5.50	Peak
Vertical									
Frequency (MHz)	Reading-PK (dBμV)	Reading-AV (dBμV)	Correction Factor (dB/m)	Result-PK (dBμV/m)	Result-AV (dBμV/m)	Limit-PK (dBμV/m)	Limit-AV (dBμV/m)	Margin (dB)	Remark
2438.00	125.00	104.83	-8.82	116.18	96.01	---	---	---	Carrier
2518.00	70.97	57.12	-8.72	62.25	48.40	74.00	54.00	-5.60	AVG
2560.00	68.63	55.59	-8.69	59.94	46.90	74.00	54.00	-7.10	AVG
4867.50	51.99	---	-4.44	47.55	---	74.00	54.00	-6.45	Peak
6495.00	48.10	---	-2.19	45.91	---	74.00	54.00	-8.09	Peak
7312.50	59.44	44.11	-0.83	58.61	43.28	74.00	54.00	-10.72	AVG
9750.00	45.96	---	2.66	48.62	---	74.00	54.00	-5.38	Peak

Remark:

1. Measuring frequencies from 1 GHz to the 10th harmonic of highest fundamental frequency.
2. Average test would be performed if the peak result were greater than the average limit.
3. Data of measurement within this frequency range shown " --- " in the table above means the reading of emissions are attenuated more than 20dB below the permissible limits or the field strength is too small to be measured.
4. Measurements above show only up to 6 maximum emissions noted, or would be lesser, with " N/A " remark, if no specific emissions from the EUT are recorded (ie: margin>20dB from the applicable limit) and considered that's already beyond the background noise floor.
5. In any 100 kHz bandwidth outside the frequency band in which the spread spectrum or digitally modulated intentional radiator is operating, the radio frequency power that is produced by the intentional radiator shall be at least 20 dB below that in the 100 kHz bandwidth within the band that contains the highest level of the desired power, based on either an RF conducted or a radiated measurement, provided the transmitter demonstrates compliance with the peak conducted power limits. If the transmitter complies with the conducted power limits based on the use of RMS averaging over a time interval, as permitted under paragraph (b)(3) of this section, the attenuation required under this paragraph shall be 30 dB instead of 20 dB.
6. Result = Reading + Correction Factor
Margin = Result - Limit
Remark Peak = Result(PK) - Limit(AV)
Remark AVG = Result(AV) - Limit(AV)



Product Name	Wireless N Router	Test Date	2009/07/28
Model	DIR-605	Test By	Rick Lin
Test Mode	IEEE 802.11g TX (CH High)	TEMP & Humidity	25.9°C, 54%

Horizontal									
Frequency (MHz)	Reading-PK (dBμV)	Reading-AV (dBμV)	Correction Factor (dB/m)	Result-PK (dBμV/m)	Result-AV (dBμV/m)	Limit-PK (dBμV/m)	Limit-AV (dBμV/m)	Margin (dB)	Remark
2462.00	111.30	---	-8.79	102.51	---	---	---	---	Carrier
4440.00	52.53	---	-5.54	47.00	---	74.00	54.00	-7.00	Peak
4927.50	50.13	---	-4.29	45.84	---	74.00	54.00	-8.16	Peak
7222.50	50.13	---	-0.90	49.23	---	74.00	54.00	-4.77	Peak
7387.50	47.18	---	-0.78	46.40	---	74.00	54.00	-7.60	Peak
9847.50	46.96	---	2.80	49.76	---	74.00	54.00	-4.24	Peak
Vertical									
Frequency (MHz)	Reading-PK (dBμV)	Reading-AV (dBμV)	Correction Factor (dB/m)	Result-PK (dBμV/m)	Result-AV (dBμV/m)	Limit-PK (dBμV/m)	Limit-AV (dBμV/m)	Margin (dB)	Remark
2460.00	117.17	98.53	-8.79	108.38	89.74	---	---	---	Carrier
2542.00	65.67	52.77	-8.70	56.97	44.07	74.00	54.00	-9.93	AVG
2576.00	66.70	53.50	-8.68	58.02	44.82	74.00	54.00	-9.18	AVG
4012.50	52.56	---	-6.62	45.95	---	74.00	54.00	-8.05	Peak
4927.50	50.26	---	-4.29	45.98	---	74.00	54.00	-8.02	Peak
6690.00	50.52	---	-1.76	48.77	---	74.00	54.00	-5.23	Peak
7387.50	48.77	---	-0.78	47.99	---	74.00	54.00	-6.01	Peak

Remark:

1. Measuring frequencies from 1 GHz to the 10th harmonic of highest fundamental frequency.
2. Average test would be performed if the peak result were greater than the average limit.
3. Data of measurement within this frequency range shown " --- " in the table above means the reading of emissions are attenuated more than 20dB below the permissible limits or the field strength is too small to be measured.
4. Measurements above show only up to 6 maximum emissions noted, or would be lesser, with " N/A " remark, if no specific emissions from the EUT are recorded (ie: margin>20dB from the applicable limit) and considered that's already beyond the background noise floor.
5. In any 100 kHz bandwidth outside the frequency band in which the spread spectrum or digitally modulated intentional radiator is operating, the radio frequency power that is produced by the intentional radiator shall be at least 20 dB below that in the 100 kHz bandwidth within the band that contains the highest level of the desired power, based on either an RF conducted or a radiated measurement, provided the transmitter demonstrates compliance with the peak conducted power limits. If the transmitter complies with the conducted power limits based on the use of RMS averaging over a time interval, as permitted under paragraph (b)(3) of this section, the attenuation required under this paragraph shall be 30 dB instead of 20 dB.
6. Result = Reading + Correction Factor
Margin = Result - Limit
Remark Peak = Result(PK) - Limit(AV)
Remark AVG = Result(AV) - Limit(AV)



Product Name	Wireless N Router	Test Date	2009/07/28
Model	DIR-605	Test By	Rick Lin
Test Mode	IEEE 802.11n HT20 TX (CH Low)	TEMP & Humidity	25.9°C, 54%

Horizontal									
Frequency (MHz)	Reading-PK (dBμV)	Reading-AV (dBμV)	Correction Factor (dB/m)	Result-PK (dBμV/m)	Result-AV (dBμV/m)	Limit-PK (dBμV/m)	Limit-AV (dBμV/m)	Margin (dB)	Remark
2412.00	110.55	---	-8.85	101.69	---	---	---	---	Carrier
4822.50	48.81	---	-4.56	44.25	---	74.00	54.00	-9.75	Peak
6322.50	49.53	---	-2.38	47.15	---	74.00	54.00	-6.85	Peak
7237.50	46.76	---	-0.89	45.88	---	74.00	54.00	-8.12	Peak
9360.00	48.96	---	2.21	51.18	---	74.00	54.00	-2.82	Peak
9645.00	46.51	---	2.51	49.02	---	74.00	54.00	-4.98	Peak
Vertical									
Frequency (MHz)	Reading-PK (dBμV)	Reading-AV (dBμV)	Correction Factor (dB/m)	Result-PK (dBμV/m)	Result-AV (dBμV/m)	Limit-PK (dBμV/m)	Limit-AV (dBμV/m)	Margin (dB)	Remark
2412.00	116.54	104.62	-8.85	107.69	95.77	---	---	---	Carrier
2484.00	66.85	53.54	-8.76	58.09	44.78	74.00	54.00	-9.22	AVG
2530.00	66.76	54.57	-8.71	58.05	45.86	74.00	54.00	-8.14	AVG
4822.50	49.22	---	-4.56	44.67	---	74.00	54.00	-9.33	Peak
5737.50	51.06	---	-3.02	48.04	---	74.00	54.00	-5.96	Peak
7237.50	47.94	---	-0.89	47.05	---	74.00	54.00	-6.95	Peak
9652.50	47.43	---	2.52	49.95	---	74.00	54.00	-4.05	Peak

Remark:

1. Measuring frequencies from 1 GHz to the 10th harmonic of highest fundamental frequency.
2. Average test would be performed if the peak result were greater than the average limit.
3. Data of measurement within this frequency range shown " --- " in the table above means the reading of emissions are attenuated more than 20dB below the permissible limits or the field strength is too small to be measured.
4. Measurements above show only up to 6 maximum emissions noted, or would be lesser, with " N/A " remark, if no specific emissions from the EUT are recorded (ie: margin>20dB from the applicable limit) and considered that's already beyond the background noise floor.
5. In any 100 kHz bandwidth outside the frequency band in which the spread spectrum or digitally modulated intentional radiator is operating, the radio frequency power that is produced by the intentional radiator shall be at least 20 dB below that in the 100 kHz bandwidth within the band that contains the highest level of the desired power, based on either an RF conducted or a radiated measurement, provided the transmitter demonstrates compliance with the peak conducted power limits. If the transmitter complies with the conducted power limits based on the use of RMS averaging over a time interval, as permitted under paragraph (b)(3) of this section, the attenuation required under this paragraph shall be 30 dB instead of 20 dB.
6. Result = Reading + Correction Factor
Margin = Result - Limit
Remark Peak = Result(PK) - Limit(AV)
Remark AVG = Result(AV) - Limit(AV)



Product Name	Wireless N Router	Test Date	2009/07/28
Model	DIR-605	Test By	Rick Lin
Test Mode	IEEE 802.11n HT20 TX (CH Middle)	TEMP & Humidity	25.9°C, 54%

Horizontal									
Frequency (MHz)	Reading-PK (dBμV)	Reading-AV (dBμV)	Correction Factor (dB/m)	Result-PK (dBμV/m)	Result-AV (dBμV/m)	Limit-PK (dBμV/m)	Limit-AV (dBμV/m)	Margin (dB)	Remark
2436.00	115.53	---	-8.82	106.71	---	---	---	---	Carrier
4875.00	50.56	---	-4.42	46.14	---	74.00	54.00	-7.86	Peak
6495.00	48.64	---	-2.19	46.45	---	74.00	54.00	-7.55	Peak
7312.50	49.20	---	-0.83	48.36	---	74.00	54.00	-5.64	Peak
9750.00	45.94	---	2.66	48.60	---	74.00	54.00	-5.40	Peak
Vertical									
Frequency (MHz)	Reading-PK (dBμV)	Reading-AV (dBμV)	Correction Factor (dB/m)	Result-PK (dBμV/m)	Result-AV (dBμV/m)	Limit-PK (dBμV/m)	Limit-AV (dBμV/m)	Margin (dB)	Remark
2436.00	119.13	108.81	-8.82	110.30	99.99	---	---	---	Carrier
2516.00	67.94	55.63	-8.72	59.22	46.91	74.00	54.00	-7.09	AVG
2558.00	67.14	54.58	-8.69	58.45	45.89	74.00	54.00	-8.11	AVG
4882.50	53.93	---	-4.40	49.52	---	74.00	54.00	-4.48	Peak
6555.00	50.77	---	-2.06	48.71	---	74.00	54.00	-5.29	Peak
7320.00	55.94	41.39	-0.83	55.11	40.56	74.00	54.00	-13.44	AVG
8850.00	48.79	35.39	1.70	50.49	37.09	74.00	54.00	-16.91	AVG

Remark:

1. Measuring frequencies from 1 GHz to the 10th harmonic of highest fundamental frequency.
2. Average test would be performed if the peak result were greater than the average limit.
3. Data of measurement within this frequency range shown " --- " in the table above means the reading of emissions are attenuated more than 20dB below the permissible limits or the field strength is too small to be measured.
4. Measurements above show only up to 6 maximum emissions noted, or would be lesser, with " N/A " remark, if no specific emissions from the EUT are recorded (ie: margin>20dB from the applicable limit) and considered that's already beyond the background noise floor.
5. In any 100 kHz bandwidth outside the frequency band in which the spread spectrum or digitally modulated intentional radiator is operating, the radio frequency power that is produced by the intentional radiator shall be at least 20 dB below that in the 100 kHz bandwidth within the band that contains the highest level of the desired power, based on either an RF conducted or a radiated measurement, provided the transmitter demonstrates compliance with the peak conducted power limits. If the transmitter complies with the conducted power limits based on the use of RMS averaging over a time interval, as permitted under paragraph (b)(3) of this section, the attenuation required under this paragraph shall be 30 dB instead of 20 dB.
6. Result = Reading + Correction Factor
Margin = Result - Limit
Remark Peak = Result(PK) - Limit(AV)
Remark AVG = Result(AV) - Limit(AV)



Product Name	Wireless N Router	Test Date	2009/07/28
Model	DIR-605	Test By	Rick Lin
Test Mode	IEEE 802.11n HT20 TX (CH High)	TEMP & Humidity	25.9°C, 54%

Horizontal									
Frequency (MHz)	Reading-PK (dBμV)	Reading-AV (dBμV)	Correction Factor (dB/m)	Result-PK (dBμV/m)	Result-AV (dBμV/m)	Limit-PK (dBμV/m)	Limit-AV (dBμV/m)	Margin (dB)	Remark
2460.00	108.58	---	-8.79	99.79	---	---	---	---	Carrier
4305.00	51.89	---	-5.08	46.81	---	74.00	54.00	-7.19	Peak
5880.00	49.31	---	-1.20	48.12	---	74.00	54.00	-5.88	Peak
7117.50	47.65	---	1.80	49.45	---	74.00	54.00	-4.55	Peak
7567.50	47.95	---	2.11	50.06	---	74.00	54.00	-3.94	Peak
8235.00	46.87	---	3.77	50.64	---	74.00	54.00	-3.36	Peak
Vertical									
Frequency (MHz)	Reading-PK (dBμV)	Reading-AV (dBμV)	Correction Factor (dB/m)	Result-PK (dBμV/m)	Result-AV (dBμV/m)	Limit-PK (dBμV/m)	Limit-AV (dBμV/m)	Margin (dB)	Remark
2462.00	115.59	103.68	-8.79	106.80	94.89	---	---	---	Carrier
2536.00	66.33	53.09	-8.71	57.62	44.38	74.00	54.00	-9.62	AVG
4357.50	50.57	---	-4.86	45.72	---	74.00	54.00	-8.28	Peak
4672.50	50.80	---	-4.13	46.67	---	74.00	54.00	-7.33	Peak
5070.00	50.75	---	-3.73	47.02	---	74.00	54.00	-6.98	Peak
6450.00	50.01	---	0.31	50.32	---	74.00	54.00	-3.68	Peak
9495.00	47.11	33.84	4.60	51.71	38.44	74.00	54.00	-15.56	AVG

Remark:

1. Measuring frequencies from 1 GHz to the 10th harmonic of highest fundamental frequency.
2. Average test would be performed if the peak result were greater than the average limit.
3. Data of measurement within this frequency range shown " --- " in the table above means the reading of emissions are attenuated more than 20dB below the permissible limits or the field strength is too small to be measured.
4. Measurements above show only up to 6 maximum emissions noted, or would be lesser, with " N/A " remark, if no specific emissions from the EUT are recorded (ie: margin>20dB from the applicable limit) and considered that's already beyond the background noise floor.
5. In any 100 kHz bandwidth outside the frequency band in which the spread spectrum or digitally modulated intentional radiator is operating, the radio frequency power that is produced by the intentional radiator shall be at least 20 dB below that in the 100 kHz bandwidth within the band that contains the highest level of the desired power, based on either an RF conducted or a radiated measurement, provided the transmitter demonstrates compliance with the peak conducted power limits. If the transmitter complies with the conducted power limits based on the use of RMS averaging over a time interval, as permitted under paragraph (b)(3) of this section, the attenuation required under this paragraph shall be 30 dB instead of 20 dB.
6. Result = Reading + Correction Factor
Margin = Result - Limit
Remark Peak = Result(PK) - Limit(AV)
Remark AVG = Result(AV) - Limit(AV)



Product Name	Wireless N Router	Test Date	2009/07/28
Model	DIR-605	Test By	Rick Lin
Test Mode	IEEE 802.11n HT40 TX (CH Low)	TEMP & Humidity	25.9°C, 54%

Horizontal									
Frequency (MHz)	Reading-PK (dBμV)	Reading-AV (dBμV)	Correction Factor (dB/m)	Result-PK (dBμV/m)	Result-AV (dBμV/m)	Limit-PK (dBμV/m)	Limit-AV (dBμV/m)	Margin (dB)	Remark
2424.00	105.30	---	-8.84	96.46	---	---	---	---	Carrier
4072.50	51.60	---	-6.10	45.51	---	74.00	54.00	-8.49	Peak
5377.50	49.93	---	-2.87	47.05	---	74.00	54.00	-6.95	Peak
6015.00	49.48	---	-0.74	48.74	---	74.00	54.00	-5.26	Peak
6375.00	48.50	---	0.13	48.63	---	74.00	54.00	-5.37	Peak
7342.50	48.00	---	1.84	49.85	---	74.00	54.00	-4.15	Peak
Vertical									
Frequency (MHz)	Reading-PK (dBμV)	Reading-AV (dBμV)	Correction Factor (dB/m)	Result-PK (dBμV/m)	Result-AV (dBμV/m)	Limit-PK (dBμV/m)	Limit-AV (dBμV/m)	Margin (dB)	Remark
2424.00	108.80	---	-8.84	99.96	---	---	---	---	Carrier
4125.00	52.04	---	-5.87	46.17	---	74.00	54.00	-7.83	Peak
4920.00	50.57	---	-3.98	46.59	---	74.00	54.00	-7.41	Peak
5692.50	49.89	---	-1.85	48.03	---	74.00	54.00	-5.97	Peak
6502.50	49.13	---	0.43	49.57	---	74.00	54.00	-4.43	Peak
7185.00	48.52	---	1.82	50.34	---	74.00	54.00	-3.66	Peak

Remark:

1. Measuring frequencies from 1 GHz to the 10th harmonic of highest fundamental frequency.
2. Average test would be performed if the peak result were greater than the average limit.
3. Data of measurement within this frequency range shown " --- " in the table above means the reading of emissions are attenuated more than 20dB below the permissible limits or the field strength is too small to be measured.
4. Measurements above show only up to 6 maximum emissions noted, or would be lesser, with " N/A " remark, if no specific emissions from the EUT are recorded (ie: margin>20dB from the applicable limit) and considered that's already beyond the background noise floor.
5. In any 100 kHz bandwidth outside the frequency band in which the spread spectrum or digitally modulated intentional radiator is operating, the radio frequency power that is produced by the intentional radiator shall be at least 20 dB below that in the 100 kHz bandwidth within the band that contains the highest level of the desired power, based on either an RF conducted or a radiated measurement, provided the transmitter demonstrates compliance with the peak conducted power limits. If the transmitter complies with the conducted power limits based on the use of RMS averaging over a time interval, as permitted under paragraph (b)(3) of this section, the attenuation required under this paragraph shall be 30 dB instead of 20 dB.
6. Result = Reading + Correction Factor
Margin = Result - Limit
Remark Peak = Result(PK) - Limit(AV)
Remark AVG = Result(AV) - Limit(AV)



Product Name	Wireless N Router	Test Date	2009/07/28
Model	DIR-605	Test By	Rick Lin
Test Mode	IEEE 802.11n HT40 TX (CH Middle)	TEMP & Humidity	25.9°C, 54%

Horizontal									
Frequency (MHz)	Reading-PK (dBμV)	Reading-AV (dBμV)	Correction Factor (dB/m)	Result-PK (dBμV/m)	Result-AV (dBμV/m)	Limit-PK (dBμV/m)	Limit-AV (dBμV/m)	Margin (dB)	Remark
2438.00	108.97	---	-8.82	100.15	---	---	---	---	Carrier
3457.50	53.16	---	-7.51	45.65	---	74.00	54.00	-8.35	Peak
4050.00	52.77	---	-6.19	46.57	---	74.00	54.00	-7.43	Peak
4500.00	51.04	---	-4.24	46.80	---	74.00	54.00	-7.20	Peak
5977.50	49.61	---	-0.86	48.76	---	74.00	54.00	-5.24	Peak
6525.00	48.64	---	0.50	49.13	---	74.00	54.00	-4.87	Peak
Vertical									
Frequency (MHz)	Reading-PK (dBμV)	Reading-AV (dBμV)	Correction Factor (dB/m)	Result-PK (dBμV/m)	Result-AV (dBμV/m)	Limit-PK (dBμV/m)	Limit-AV (dBμV/m)	Margin (dB)	Remark
2440.00	114.72	---	-8.82	105.90	---	---	---	---	Carrier
4485.00	51.23	---	-4.30	46.93	---	74.00	54.00	-7.07	Peak
4830.00	50.86	---	-4.03	46.82	---	74.00	54.00	-7.18	Peak
5767.50	49.42	---	-1.59	47.83	---	74.00	54.00	-6.17	Peak
6465.00	48.35	---	0.34	48.69	---	74.00	54.00	-5.31	Peak
7275.00	47.97	---	1.83	49.80	---	74.00	54.00	-4.20	Peak

Remark:

1. Measuring frequencies from 1 GHz to the 10th harmonic of highest fundamental frequency.
2. Average test would be performed if the peak result were greater than the average limit.
3. Data of measurement within this frequency range shown " --- " in the table above means the reading of emissions are attenuated more than 20dB below the permissible limits or the field strength is too small to be measured.
4. Measurements above show only up to 6 maximum emissions noted, or would be lesser, with " N/A " remark, if no specific emissions from the EUT are recorded (ie: margin>20dB from the applicable limit) and considered that's already beyond the background noise floor.
5. In any 100 kHz bandwidth outside the frequency band in which the spread spectrum or digitally modulated intentional radiator is operating, the radio frequency power that is produced by the intentional radiator shall be at least 20 dB below that in the 100 kHz bandwidth within the band that contains the highest level of the desired power, based on either an RF conducted or a radiated measurement, provided the transmitter demonstrates compliance with the peak conducted power limits. If the transmitter complies with the conducted power limits based on the use of RMS averaging over a time interval, as permitted under paragraph (b)(3) of this section, the attenuation required under this paragraph shall be 30 dB instead of 20 dB.
6. Result = Reading + Correction Factor
Margin = Result - Limit
Remark Peak = Result(PK) - Limit(AV)
Remark AVG = Result(AV) - Limit(AV)



Product Name	Wireless N Router	Test Date	2009/07/28
Model	DIR-605	Test By	Rick Lin
Test Mode	IEEE 802.11n HT40 TX (CH High)	TEMP & Humidity	25.9°C, 54%

Horizontal									
Frequency (MHz)	Reading-PK (dBμV)	Reading-AV (dBμV)	Correction Factor (dB/m)	Result-PK (dBμV/m)	Result-AV (dBμV/m)	Limit-PK (dBμV/m)	Limit-AV (dBμV/m)	Margin (dB)	Remark
2450.00	103.24	---	-8.80	94.44	---	---	---	---	Carrier
5002.50	51.28	---	-3.92	47.35	---	74.00	54.00	-6.65	Peak
5625.00	50.19	---	-2.09	48.10	---	74.00	54.00	-5.90	Peak
6525.00	48.68	---	0.50	49.17	---	74.00	54.00	-4.83	Peak
7057.50	47.54	---	1.79	49.33	---	74.00	54.00	-4.67	Peak
7905.00	46.86	---	3.30	50.16	---	74.00	54.00	-3.84	Peak
Vertical									
Frequency (MHz)	Reading-PK (dBμV)	Reading-AV (dBμV)	Correction Factor (dB/m)	Result-PK (dBμV/m)	Result-AV (dBμV/m)	Limit-PK (dBμV/m)	Limit-AV (dBμV/m)	Margin (dB)	Remark
2448.00	111.30	---	-8.81	102.49	---	---	---	---	Carrier
3412.50	52.54	---	-7.60	44.94	---	74.00	54.00	-9.06	Peak
3735.00	51.74	---	-6.95	44.78	---	74.00	54.00	-9.22	Peak
4305.00	51.27	---	-5.08	46.18	---	74.00	54.00	-7.82	Peak
6007.50	49.34	---	-0.76	48.58	---	74.00	54.00	-5.42	Peak
6570.00	48.83	---	0.62	49.45	---	74.00	54.00	-4.55	Peak
7792.50	47.64	---	2.91	50.55	---	74.00	54.00	-3.45	Peak

Remark:

1. Measuring frequencies from 1 GHz to the 10th harmonic of highest fundamental frequency.
2. Average test would be performed if the peak result were greater than the average limit.
3. Data of measurement within this frequency range shown " --- " in the table above means the reading of emissions are attenuated more than 20dB below the permissible limits or the field strength is too small to be measured.
4. Measurements above show only up to 6 maximum emissions noted, or would be lesser, with " N/A " remark, if no specific emissions from the EUT are recorded (ie: margin>20dB from the applicable limit) and considered that's already beyond the background noise floor.
5. In any 100 kHz bandwidth outside the frequency band in which the spread spectrum or digitally modulated intentional radiator is operating, the radio frequency power that is produced by the intentional radiator shall be at least 20 dB below that in the 100 kHz bandwidth within the band that contains the highest level of the desired power, based on either an RF conducted or a radiated measurement, provided the transmitter demonstrates compliance with the peak conducted power limits. If the transmitter complies with the conducted power limits based on the use of RMS averaging over a time interval, as permitted under paragraph (b)(3) of this section, the attenuation required under this paragraph shall be 30 dB instead of 20 dB.
6. Result = Reading + Correction Factor
Margin = Result - Limit
Remark Peak = Result(PK) - Limit(AV)
Remark AVG = Result(AV) - Limit(AV)



8.8.4 RESTRICTED BAND EDGES

Detector mode : Peak

Polarity : Horizontal

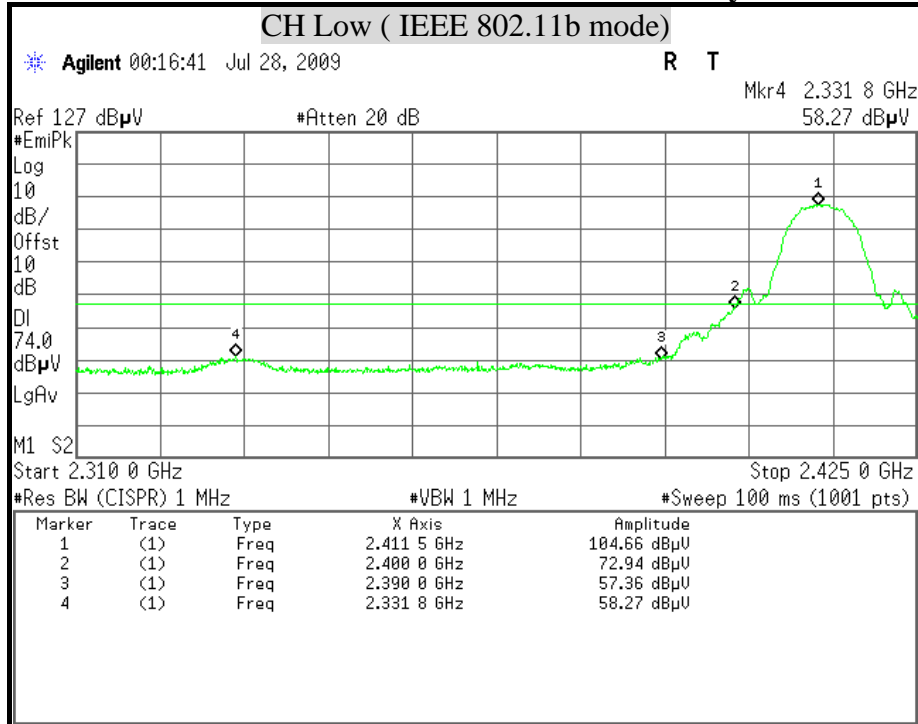

Detector mode : Average

Polarity : Horizontal

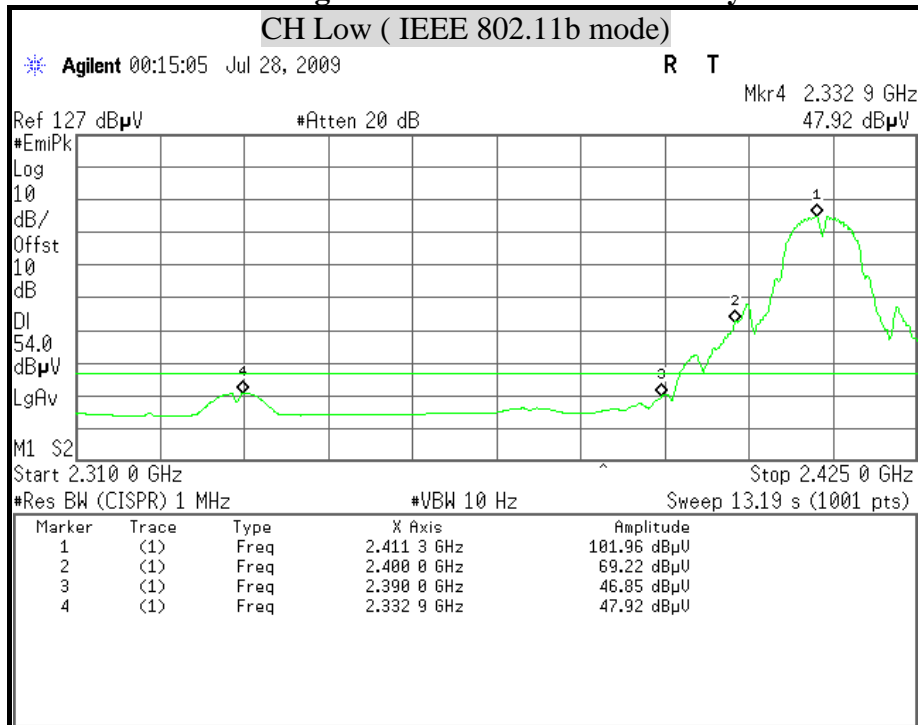



Detector mode : Peak

Polarity : Vertical

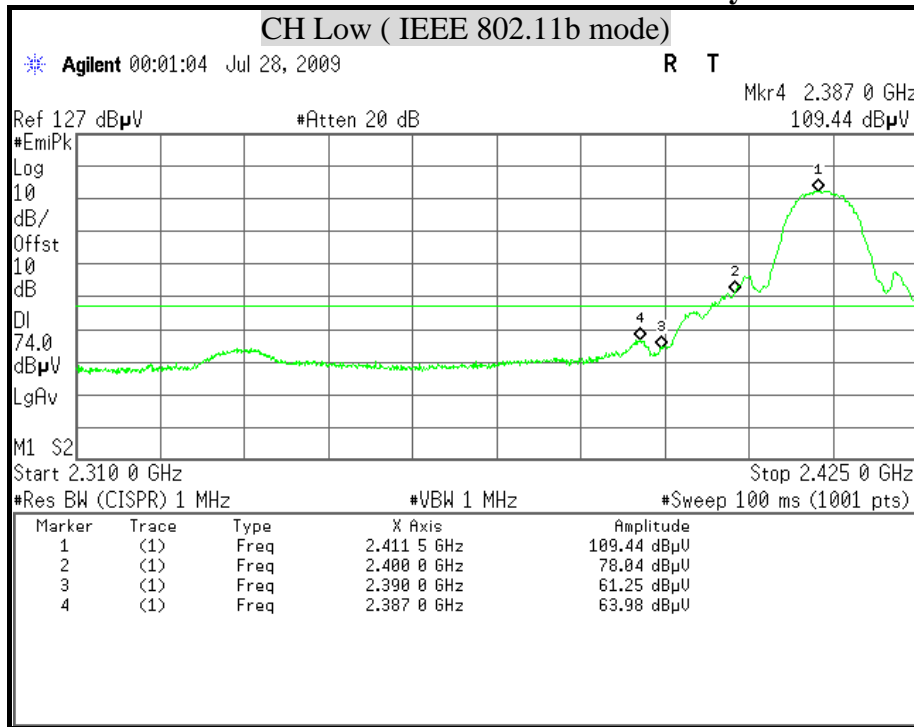

Detector mode : Average

Polarity : Vertical

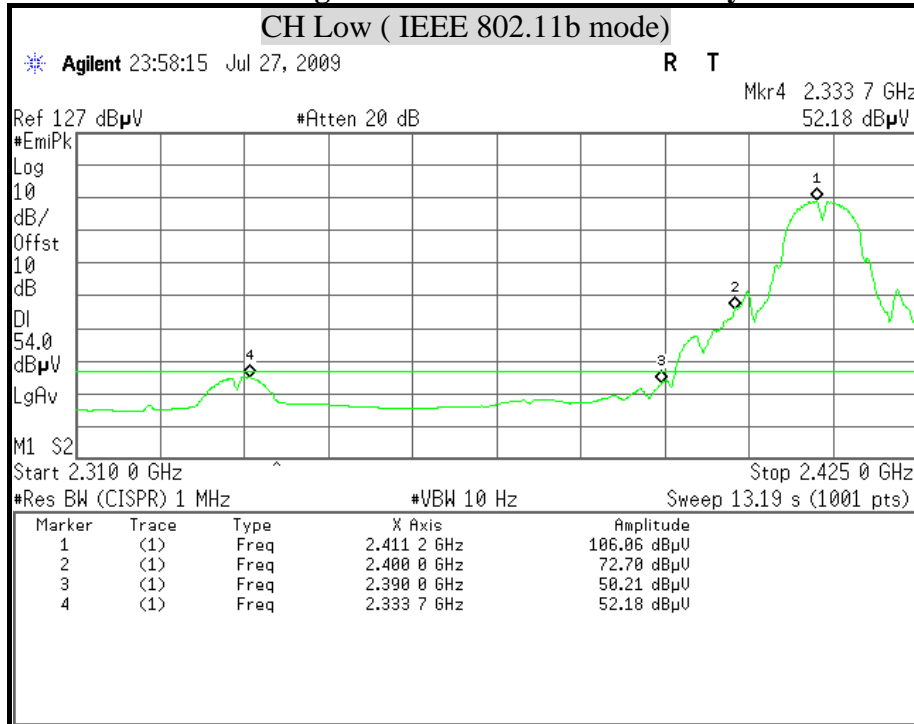



Detector mode : Peak

Polarity : Horizontal

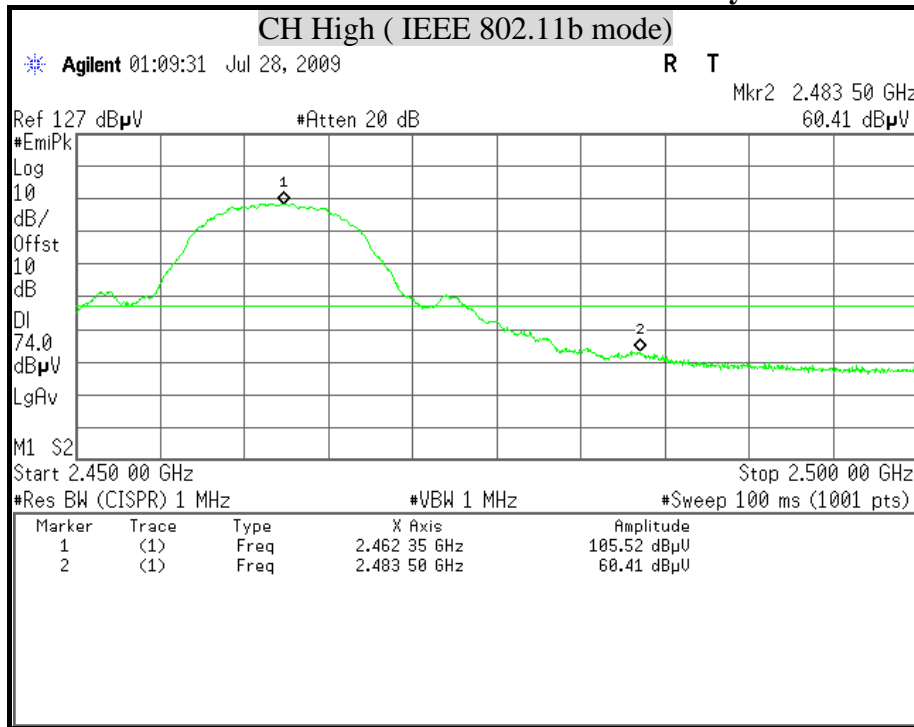

Detector mode : Average

Polarity : Horizontal

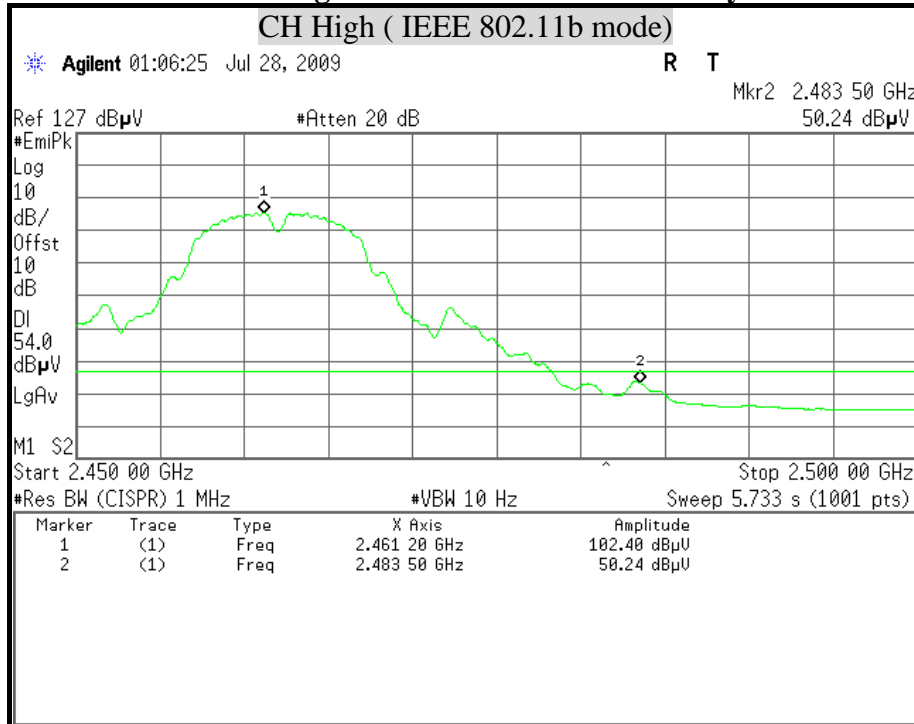



Detector mode : Peak

Polarity : Vertical

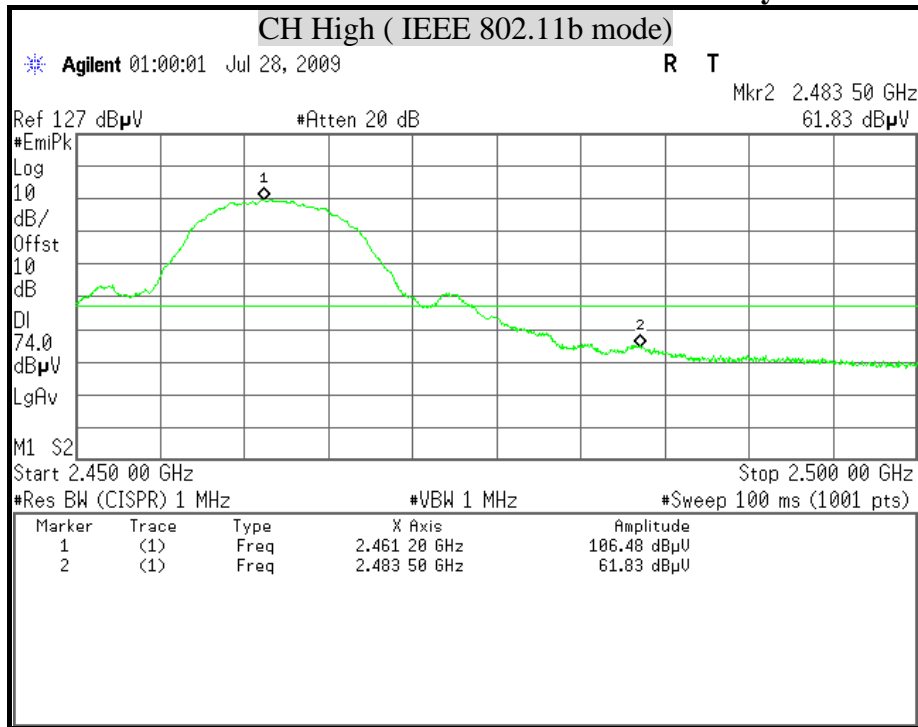

Detector mode : Average

Polarity : Vertical

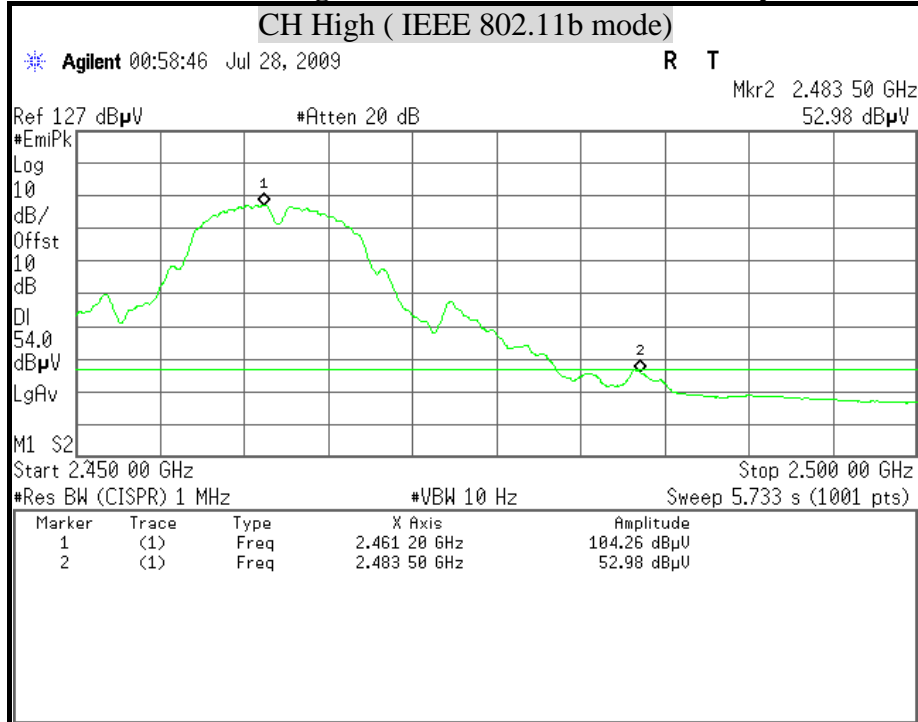



Detector mode : Peak

Polarity : Horizontal

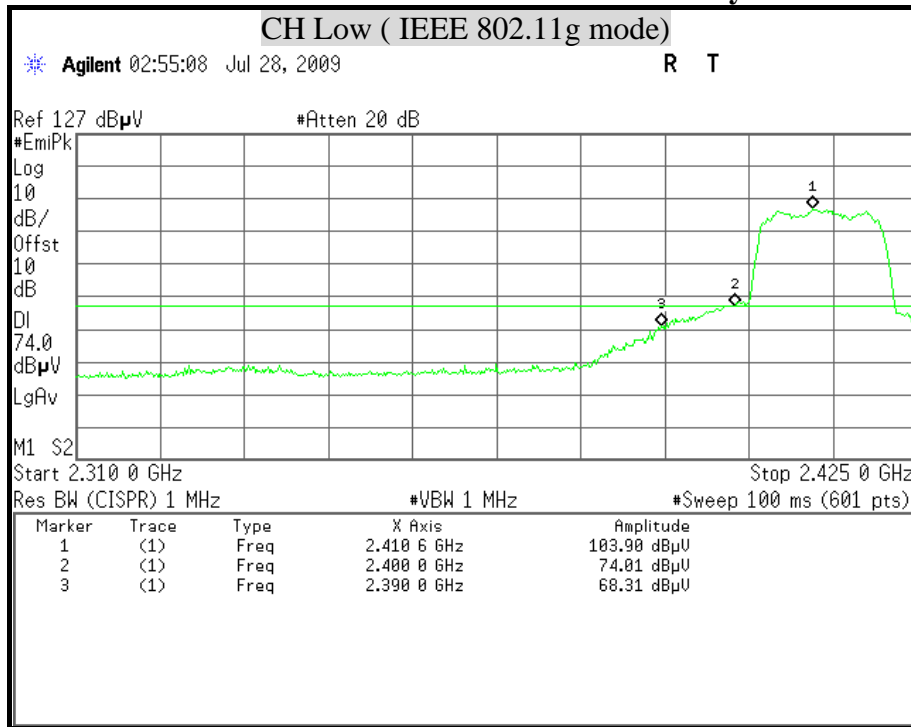

Detector mode : Average

Polarity : Horizontal

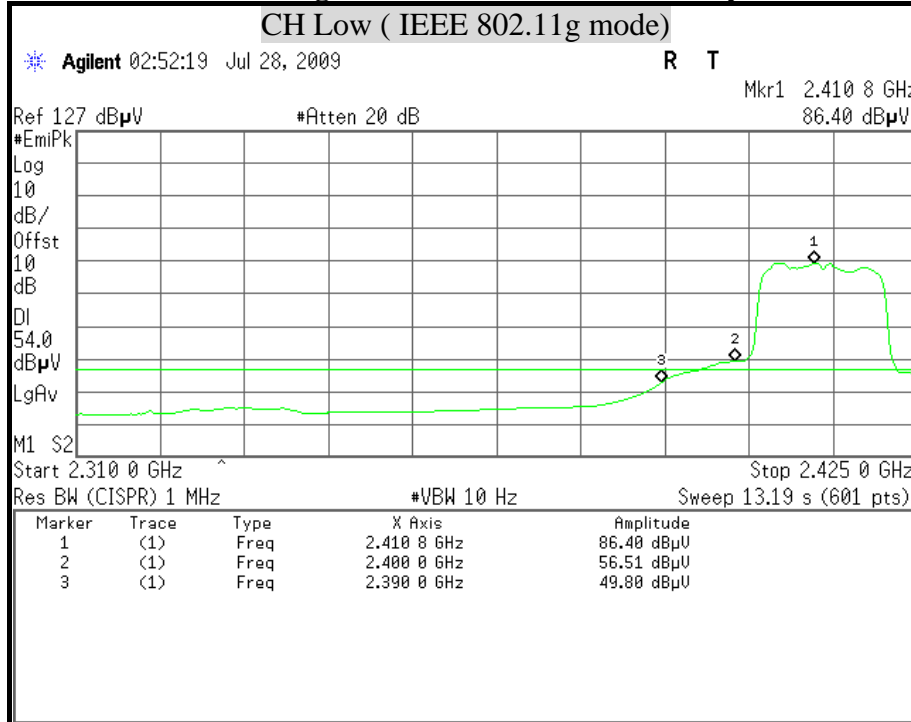



Detector mode : Peak

Polarity : Vertical

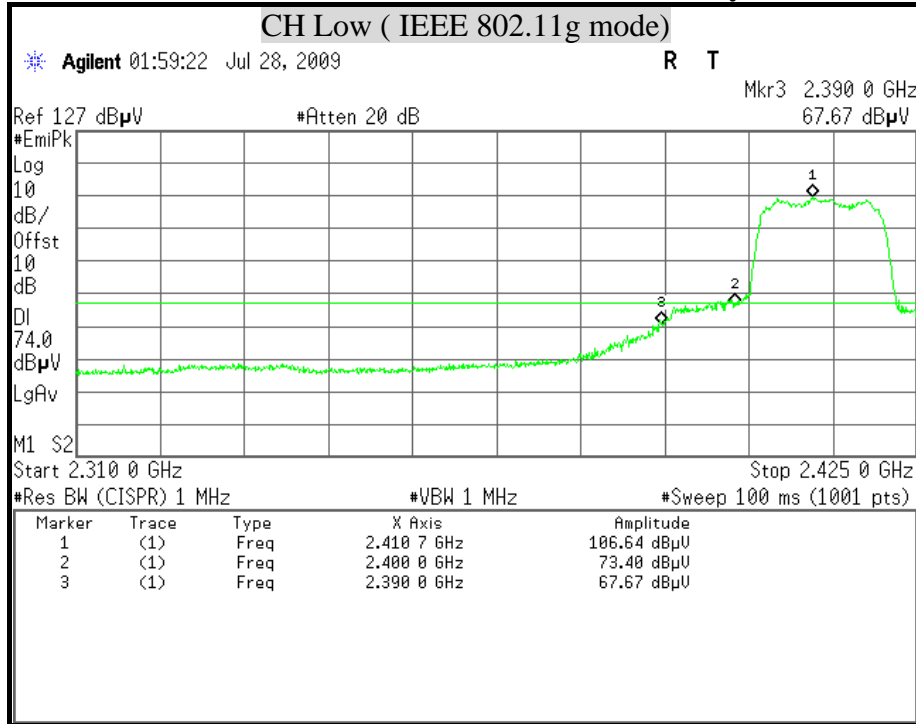

Detector mode : Average

Polarity : Vertical

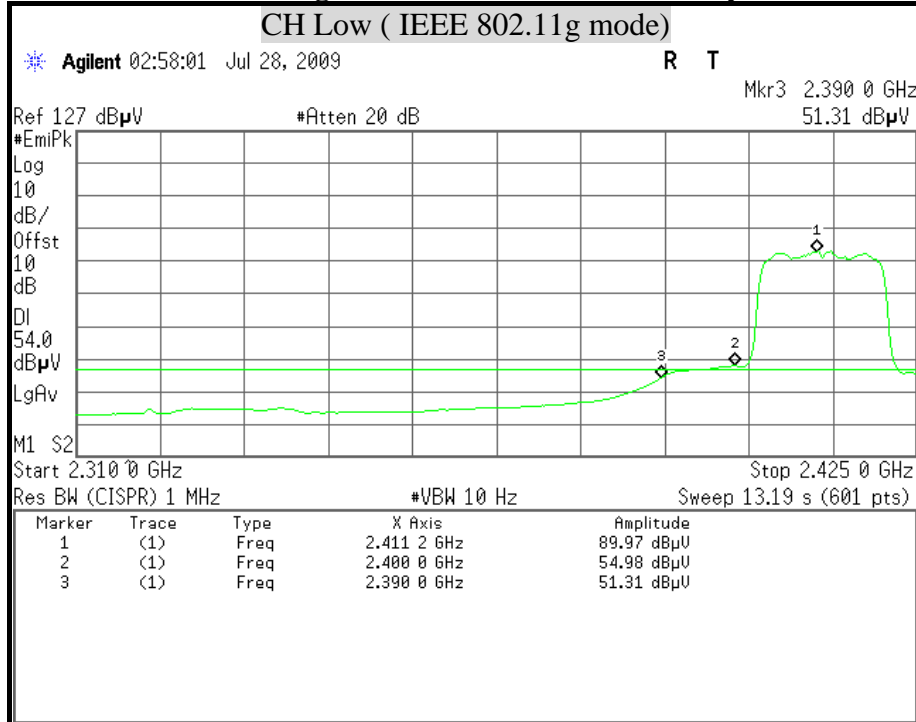



Detector mode : Peak

Polarity : Horizontal

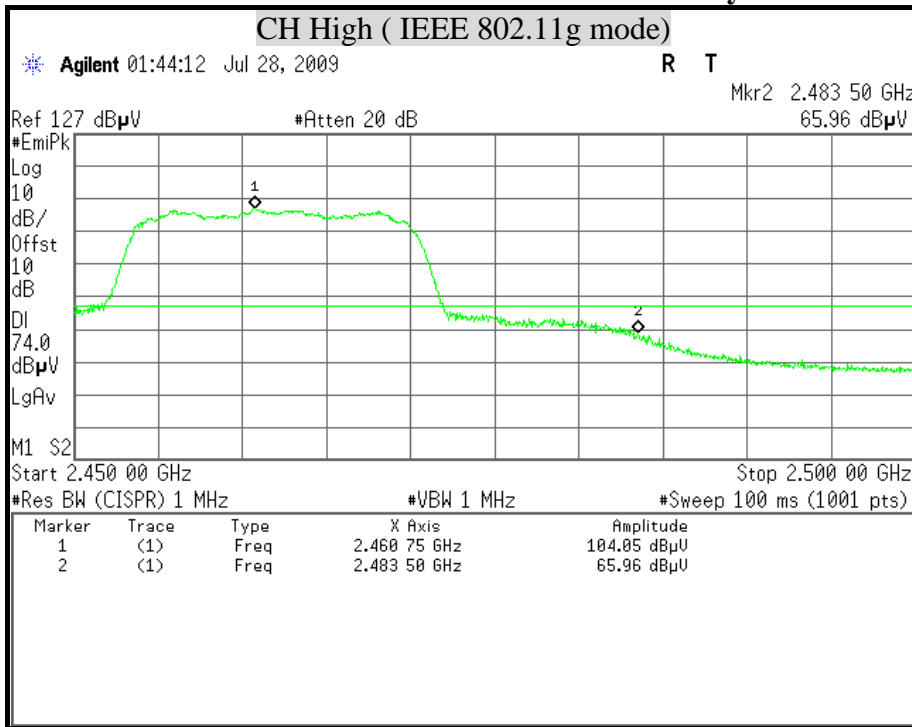

Detector mode : Average

Polarity : Horizontal

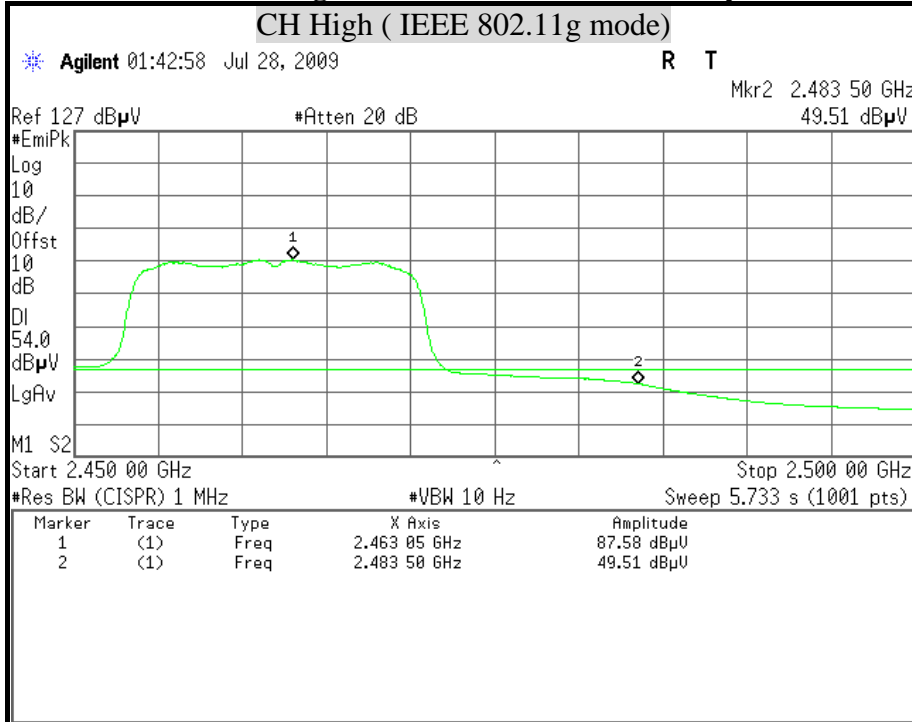



Detector mode : Peak

Polarity : Vertical

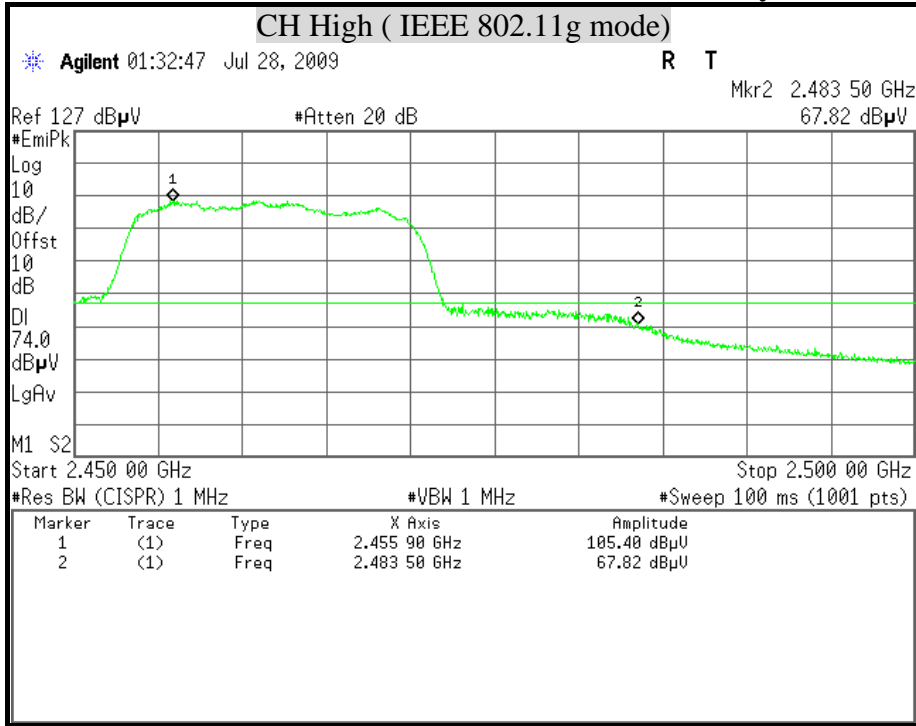

Detector mode : Average

Polarity : Vertical

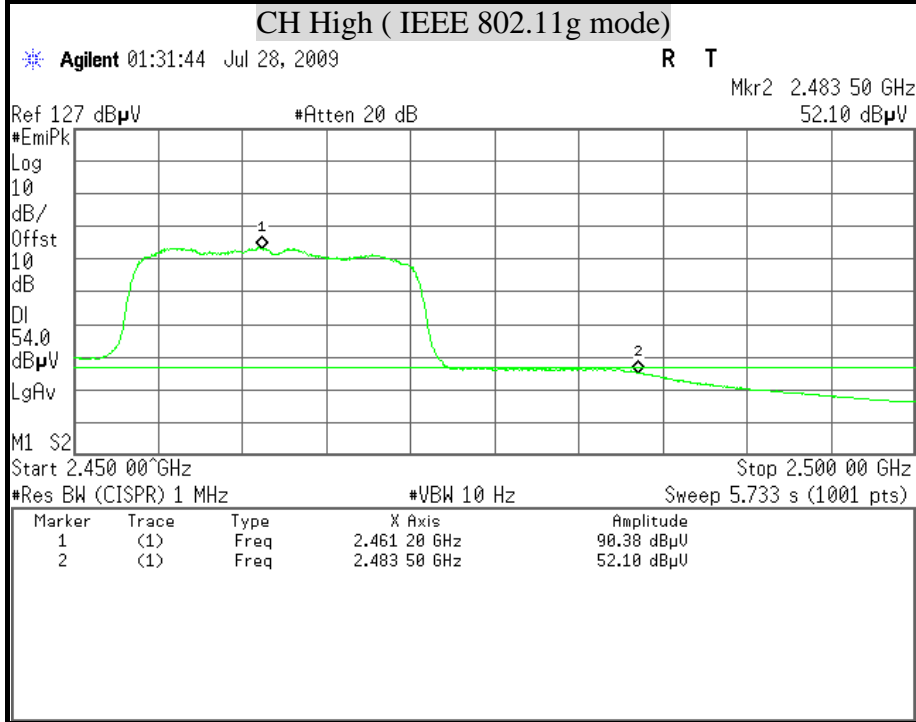



Detector mode : Peak

Polarity : Horizontal

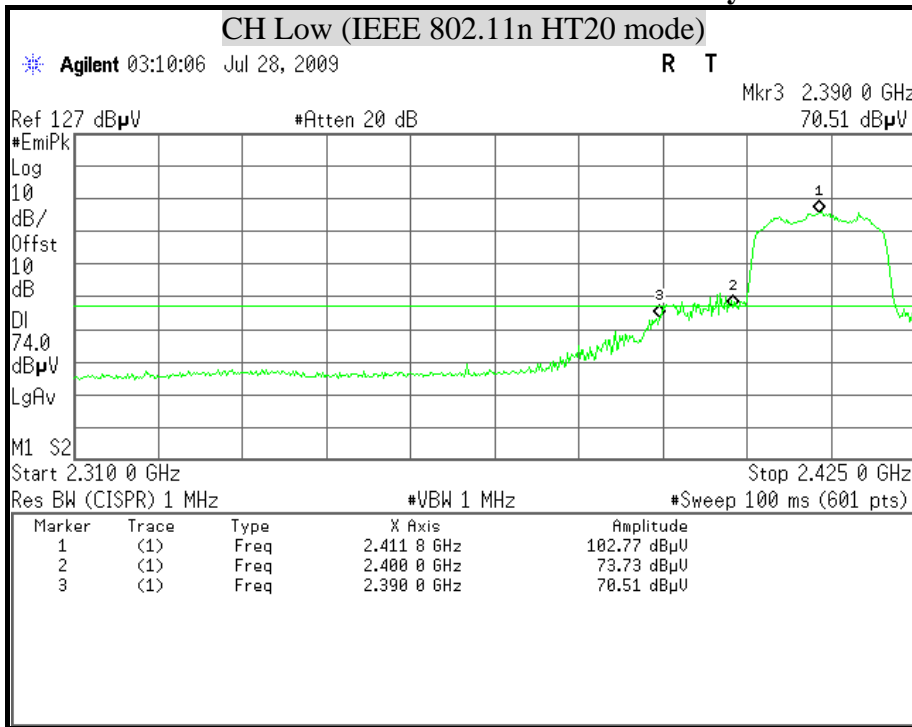

Detector mode : Average

Polarity : Horizontal

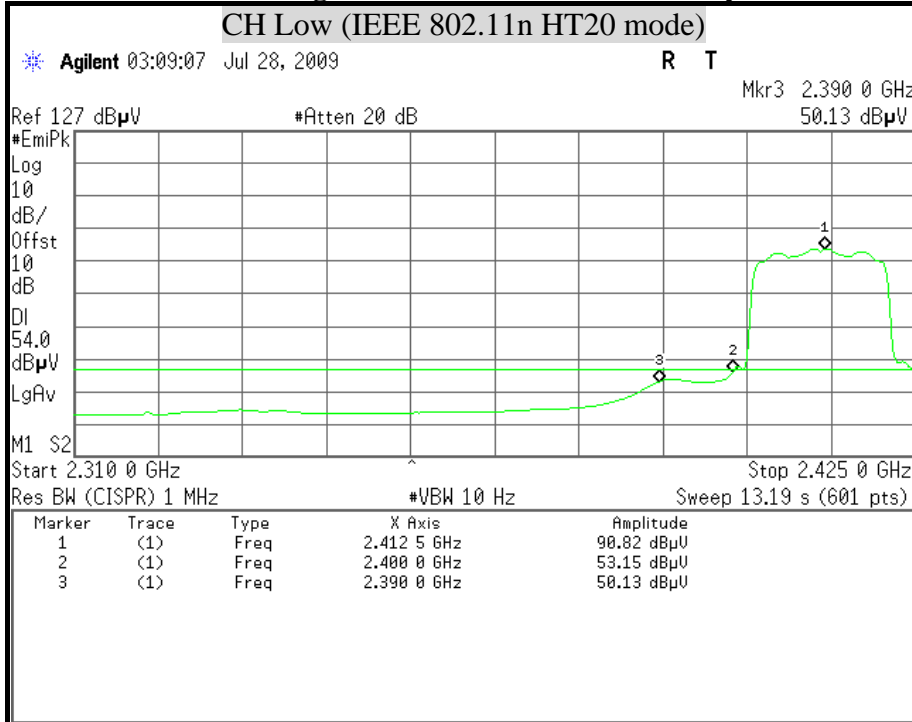



Detector mode : Peak

Polarity : Vertical

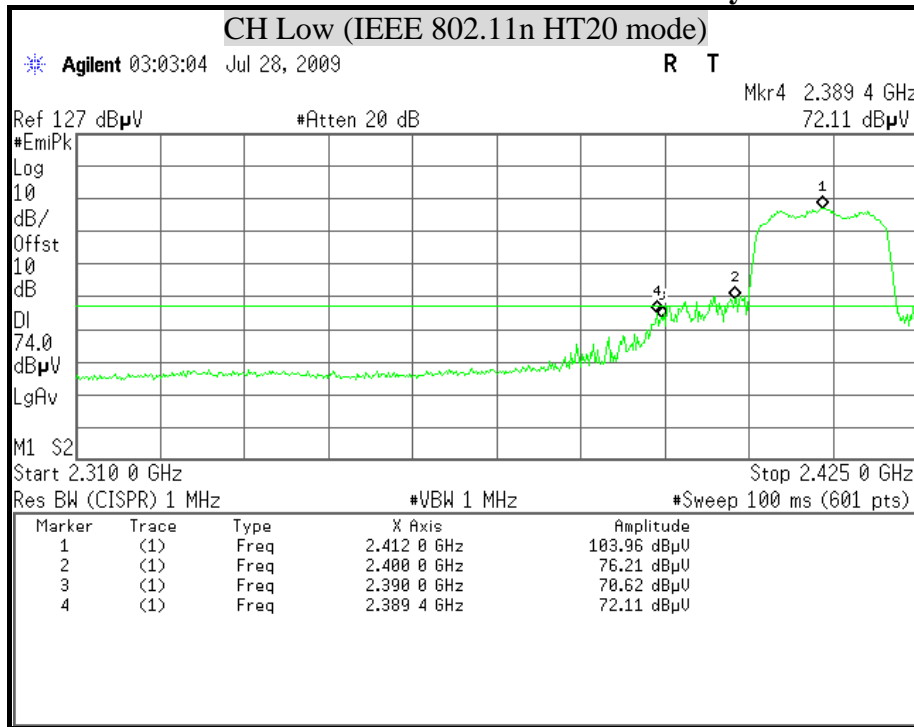

Detector mode : Average

Polarity : Vertical

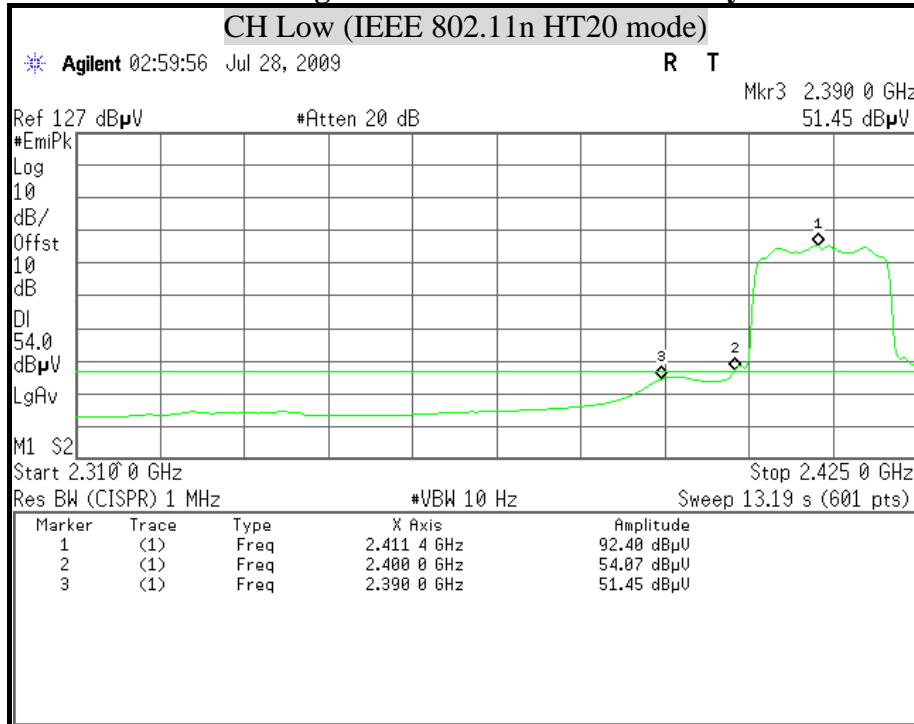



Detector mode : Peak

Polarity : Horizontal

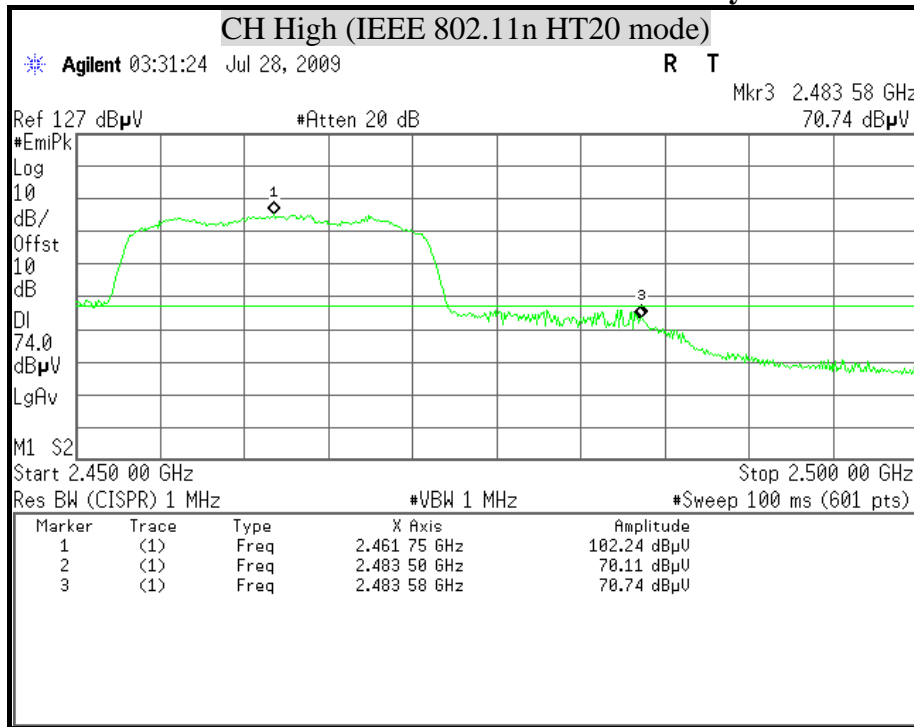

Detector mode : Average

Polarity : Horizontal

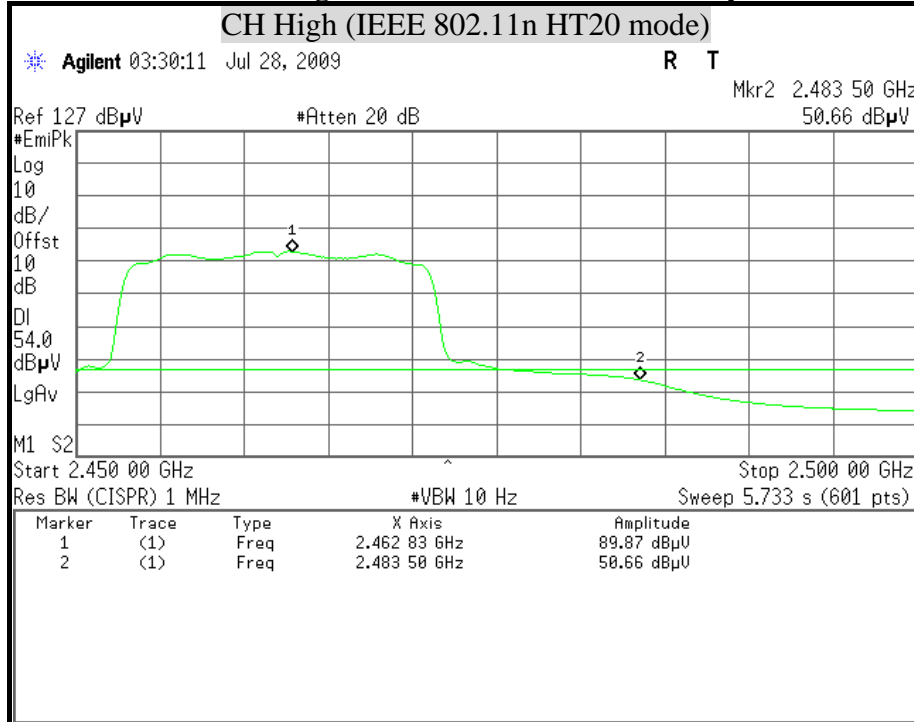



Detector mode : Peak

Polarity : Vertical

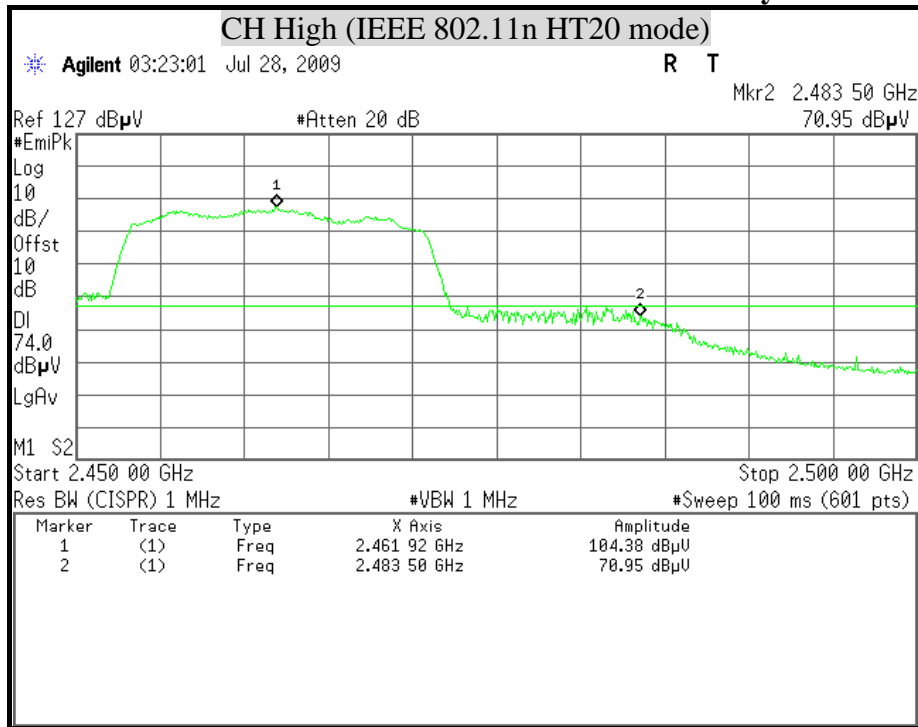

Detector mode : Average

Polarity : Vertical

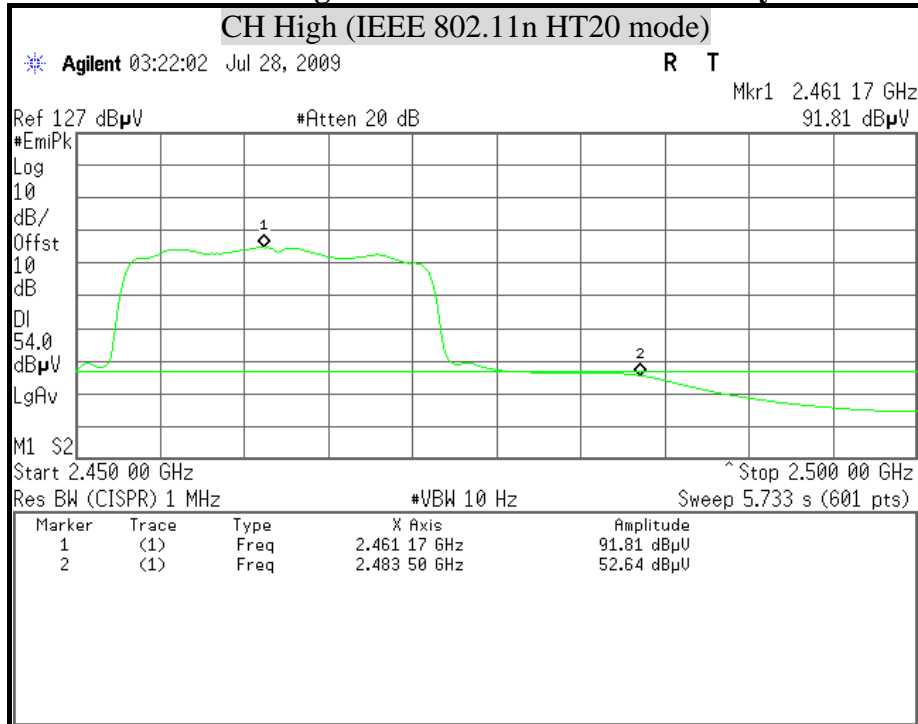



Detector mode : Peak

Polarity : Horizontal

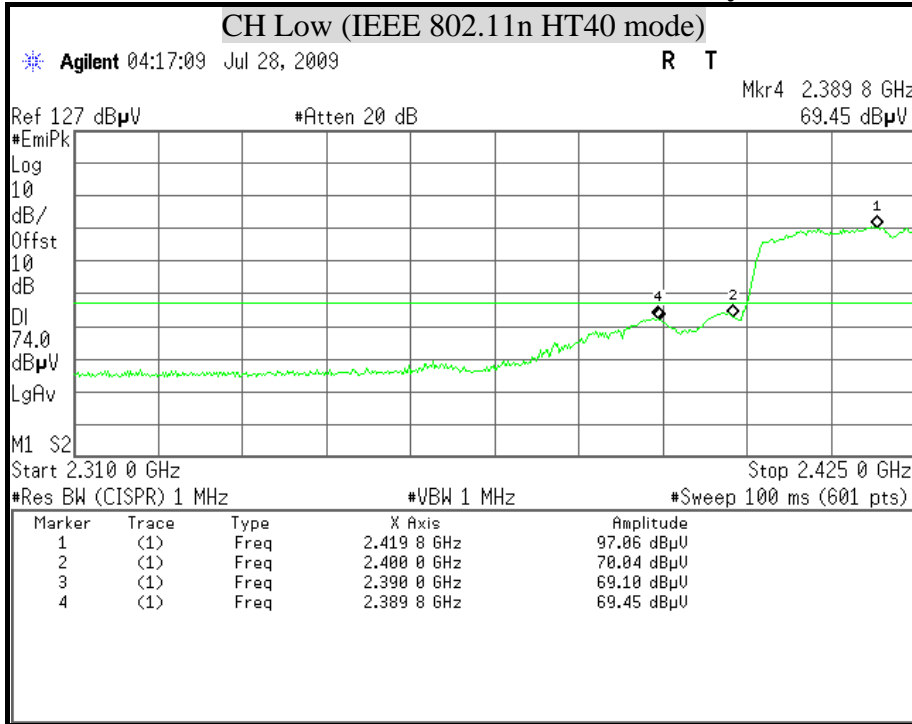

Detector mode : Average

Polarity : Horizontal

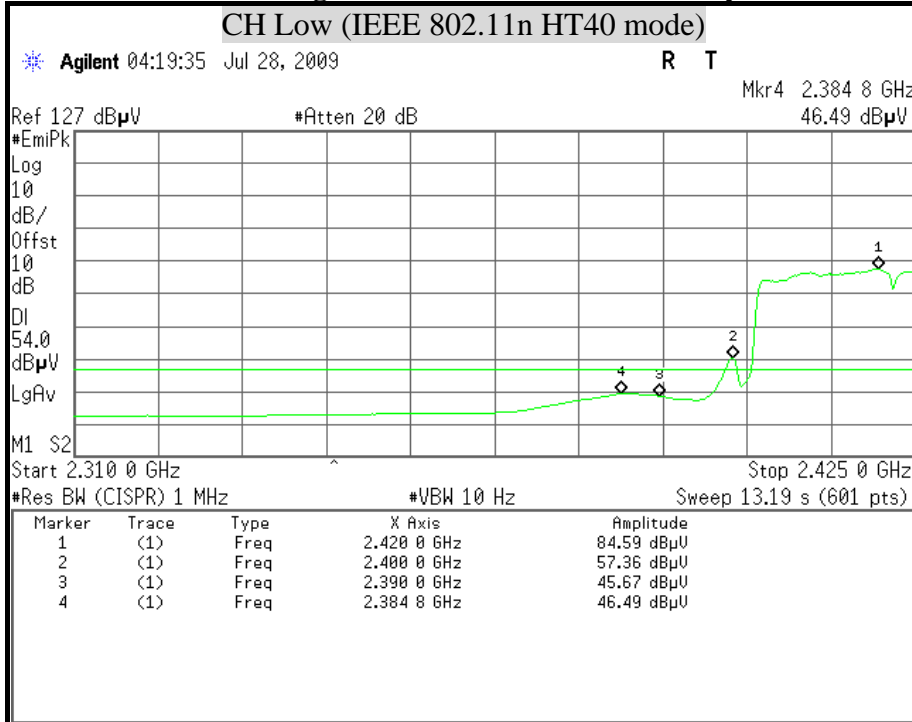



Detector mode : Peak

Polarity : Vertical

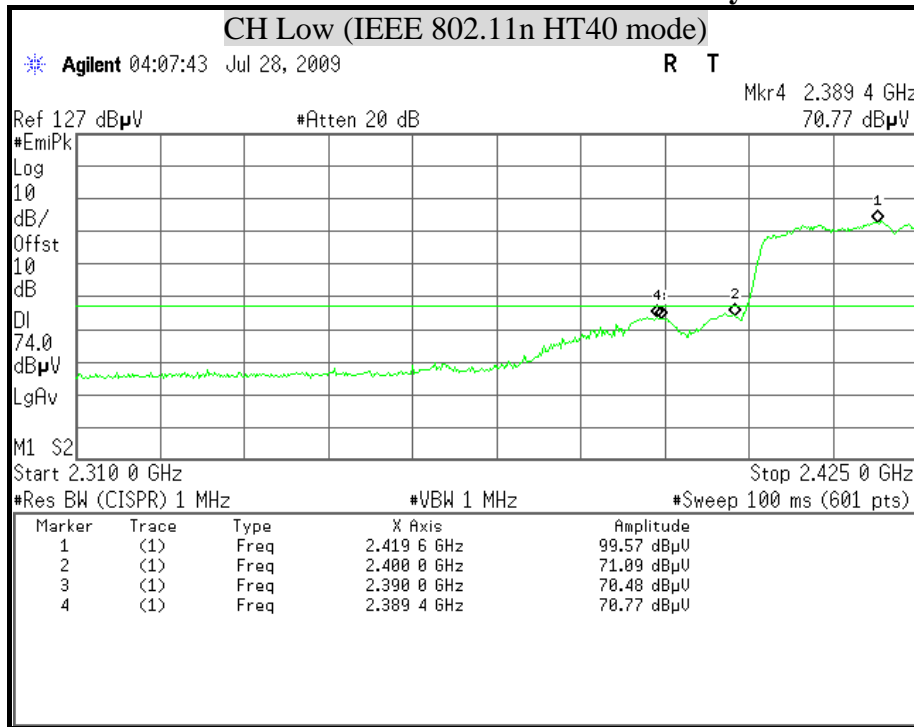

Detector mode : Average

Polarity : Vertical

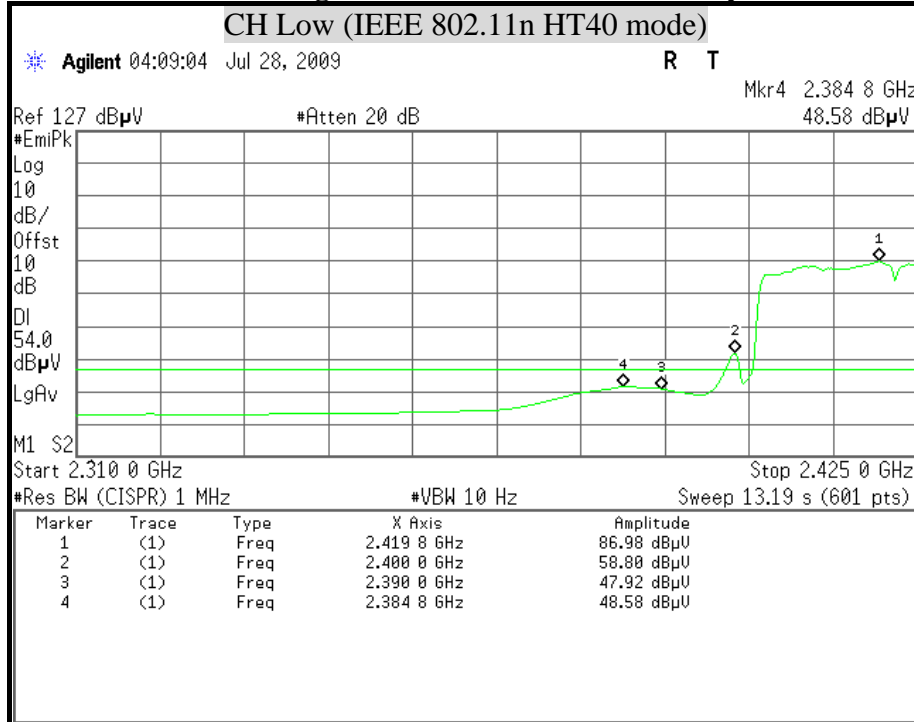



Detector mode : Peak

Polarity : Horizontal

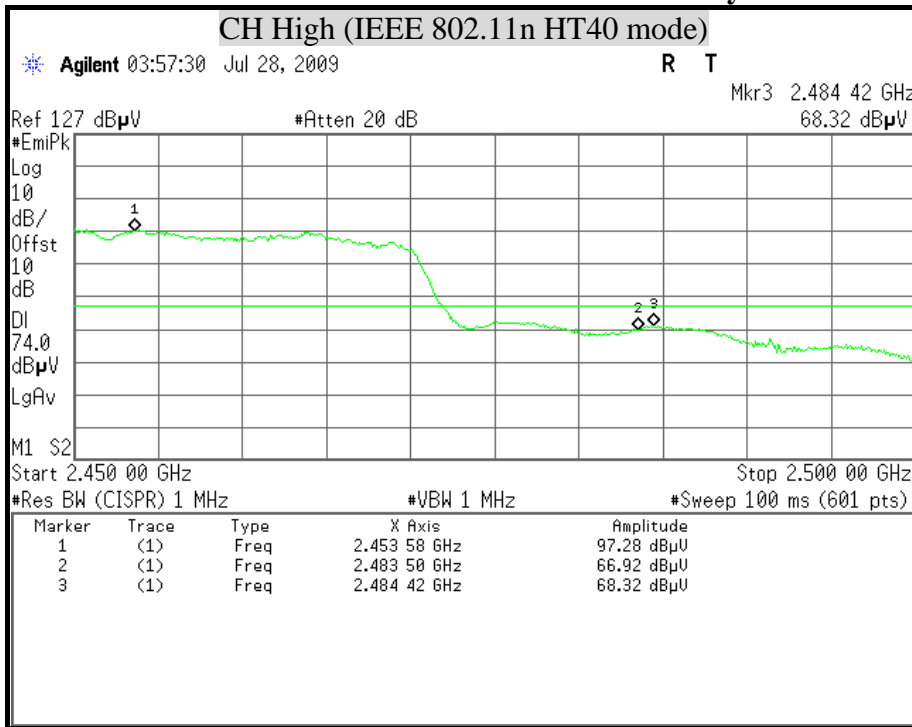

Detector mode : Average

Polarity : Horizontal

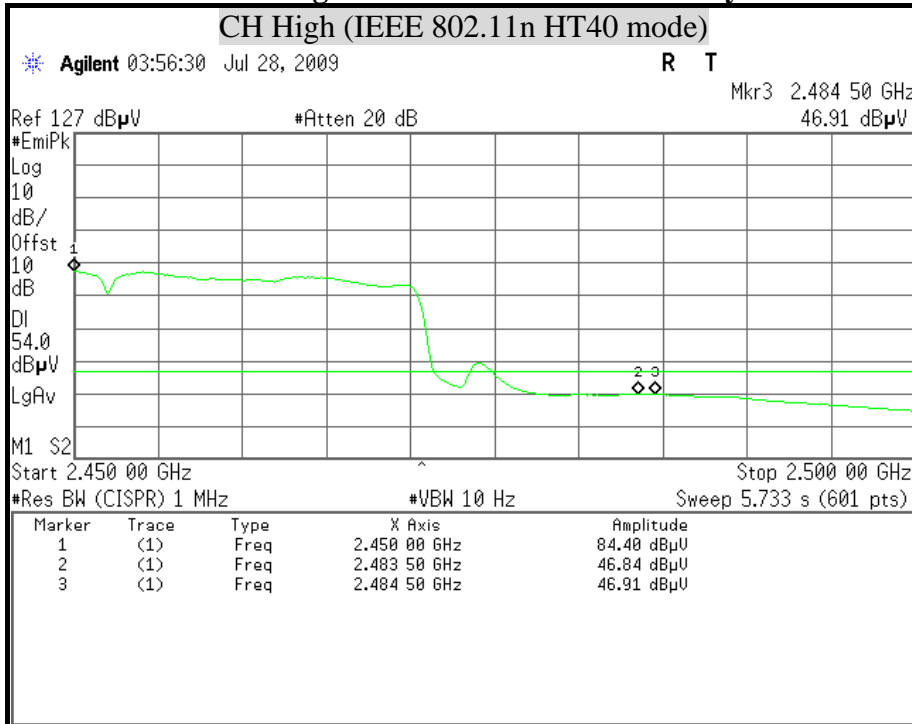



Detector mode : Peak

Polarity : Vertical

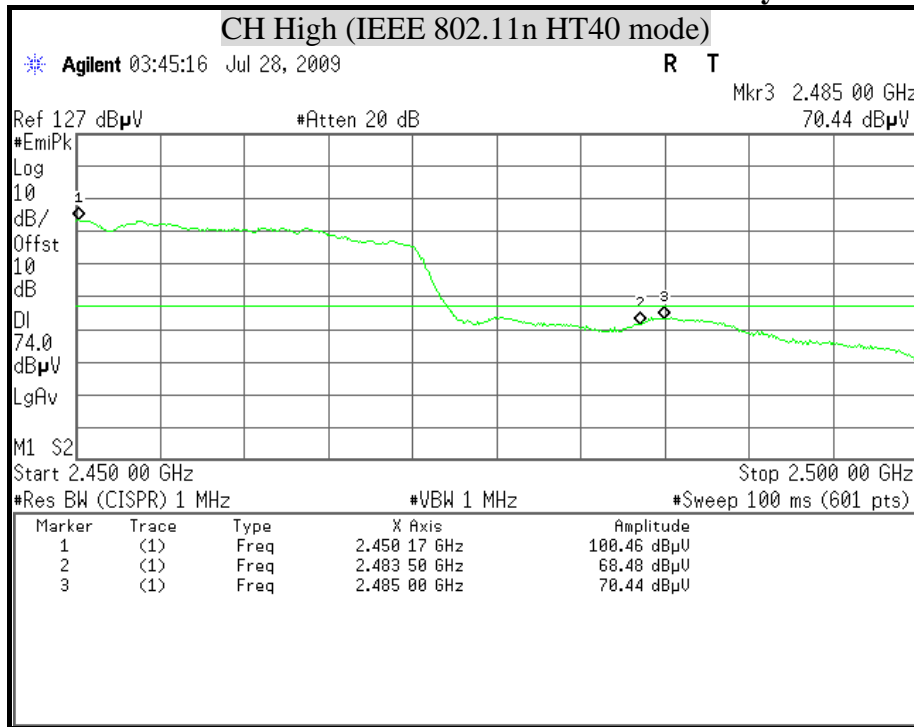

Detector mode : Average

Polarity : Vertical

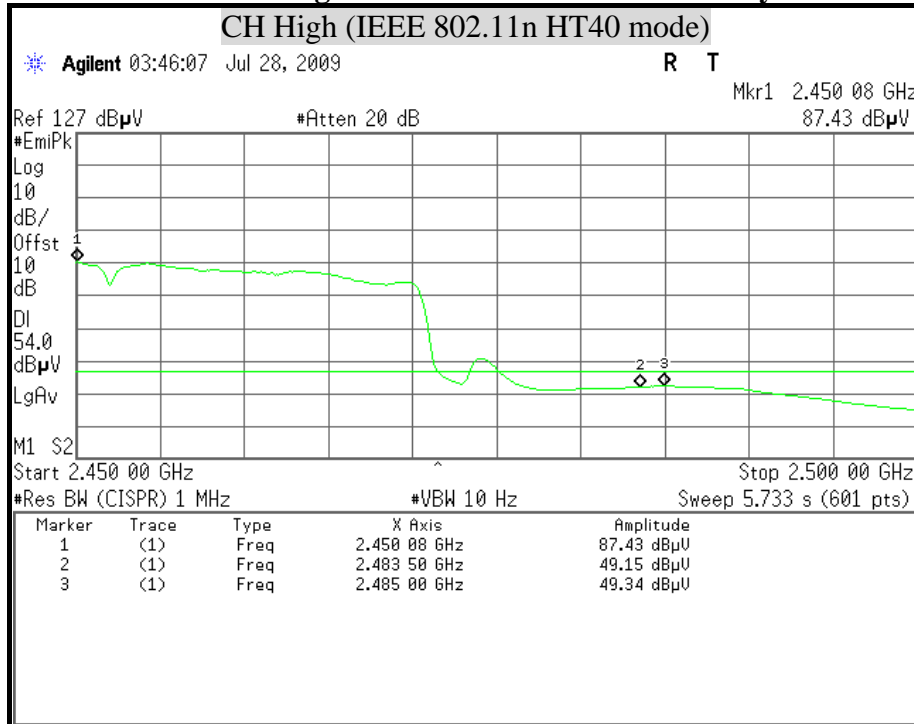



8.9 POWERLINE CONDUCTED EMISSIONS

LIMITS

§ 15.207 (a) Except as shown in paragraph (b) and (c) this section, for an intentional radiator that is designed to be connected to the public utility (AC) power line, the radio frequency voltage that is conducted back onto the AC power line on any frequency or frequencies within the band 150 kHz to 30 MHz shall not exceed the limits in the following table, as measured using a 50 μ H/50 ohms line impedance stabilization network (LISN). Compliance with the provisions of this paragraph shall be based on the measurement of the radio frequency voltage between each power line and ground at the power terminal.

The lower limit applies at the boundary between the frequency ranges.

Frequency of Emission (MHz)	Conducted limit (dB μ v)	
	Quasi-peak	Average
0.15 - 0.5	66 to 56	56 to 46
0.5 - 5	56	46
5 - 30	60	50

TEST EQUIPMENT

Name of Equipment	Manufacturer	Model	Serial Number	Calibration Due
L.I.S.N	SCHWARZBECK	NSLK 8127	8127-465	08/13/2009
L.I.S.N	SCHWARZBECK	NSLK 8127	8127-473	10/12/2009
TEST RECEIVER	R & S	ESHS 30	838550/003	02/02/2010
TEST RECEIVER	R & S	ESCS 30	826547/004	08/05/2010
PULSE LIMIT	R & S	ESH3-Z2	100117	09/23/2009
N TYPE COAXIAL CABLE	BELDEN	8268 M17/164	003	07/09/2010

Remark: Each piece of equipment is scheduled for calibration once a year.

TEST SETUP

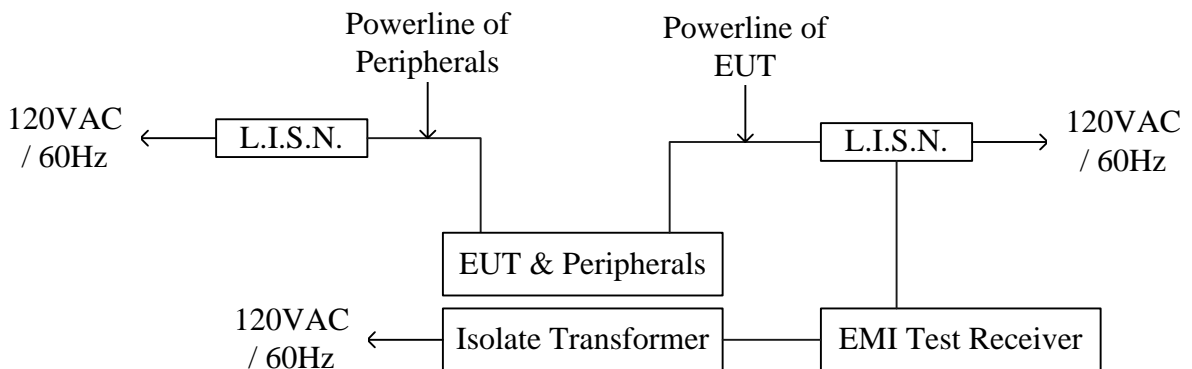
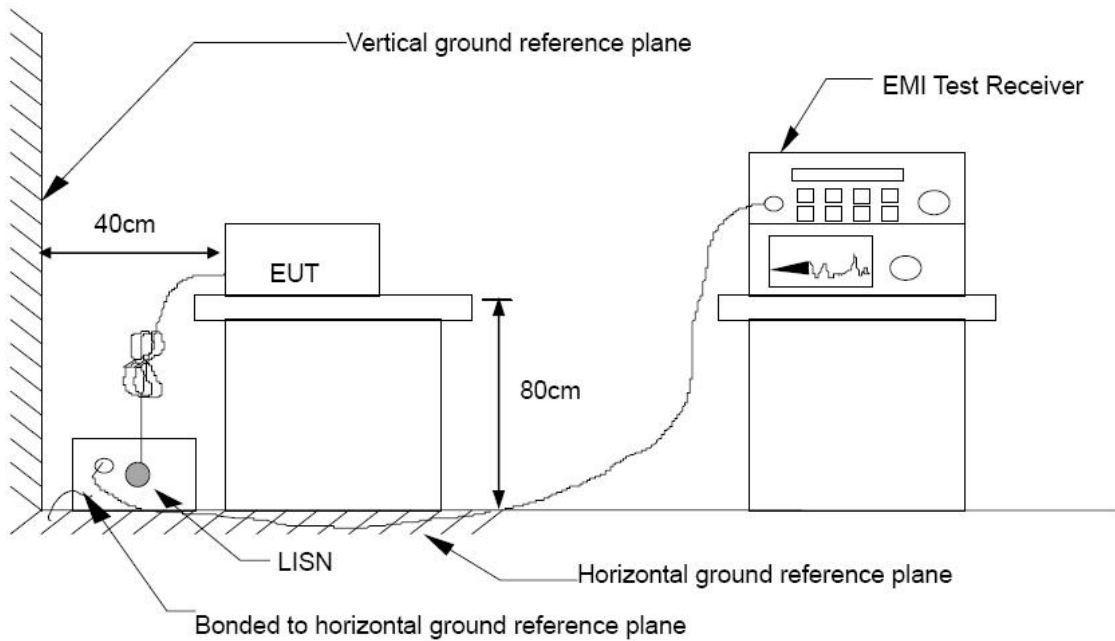

TEST PROCEDURE

The EUT is placed on a non-conducting table 40 cm from the vertical ground plane and 80cm above the horizontal ground plane. The EUT IS CONFIGURED IN ACCORDANCE WITH ANSI C63.4 : 2003.

The resolution bandwidth is set to 9 kHz for both quasi-peak detection and average detection measurements.

Line conducted data is recorded for both NEUTRAL and LINE.

**TEST RESULTS**

Product Name	Wireless N Router	Test Date	2009/07/29
Model	DIR-605	Test By	Rueyyan Lin
Test Mode	Normal operating (worst-case)	TEMP & Humidity	23.1°C, 58%

LINE

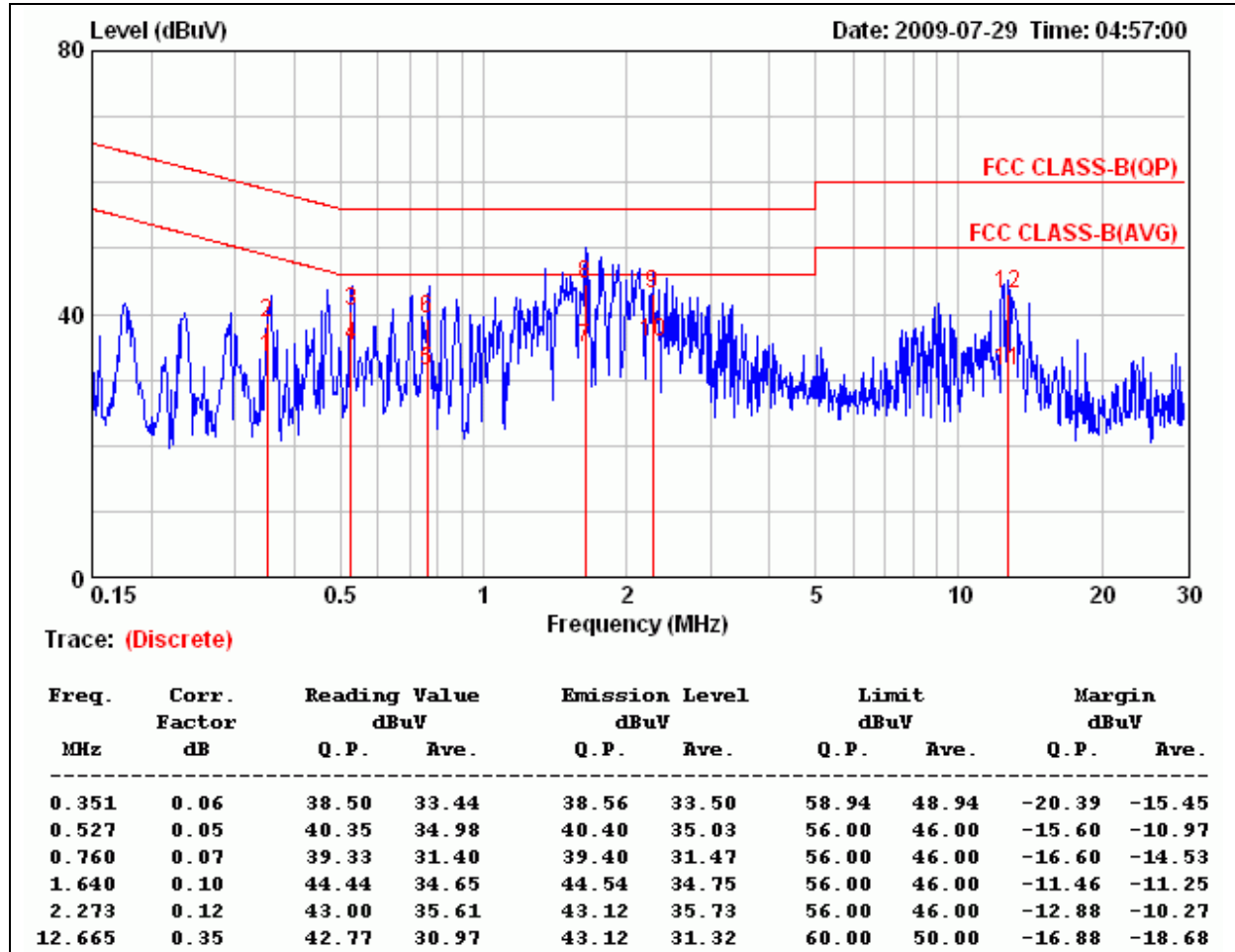
**Remark:**

1. Correction Factor = Insertion loss + cable loss
2. Margin value = Emission level - Limit value



Product Name	Wireless N Router	Test Date	2009/07/29
Model	DIR-605	Test By	Rueyyan Lin
Test Mode	Normal operating (worst-case)	TEMP & Humidity	23.1°C, 58%

NEUTRAL

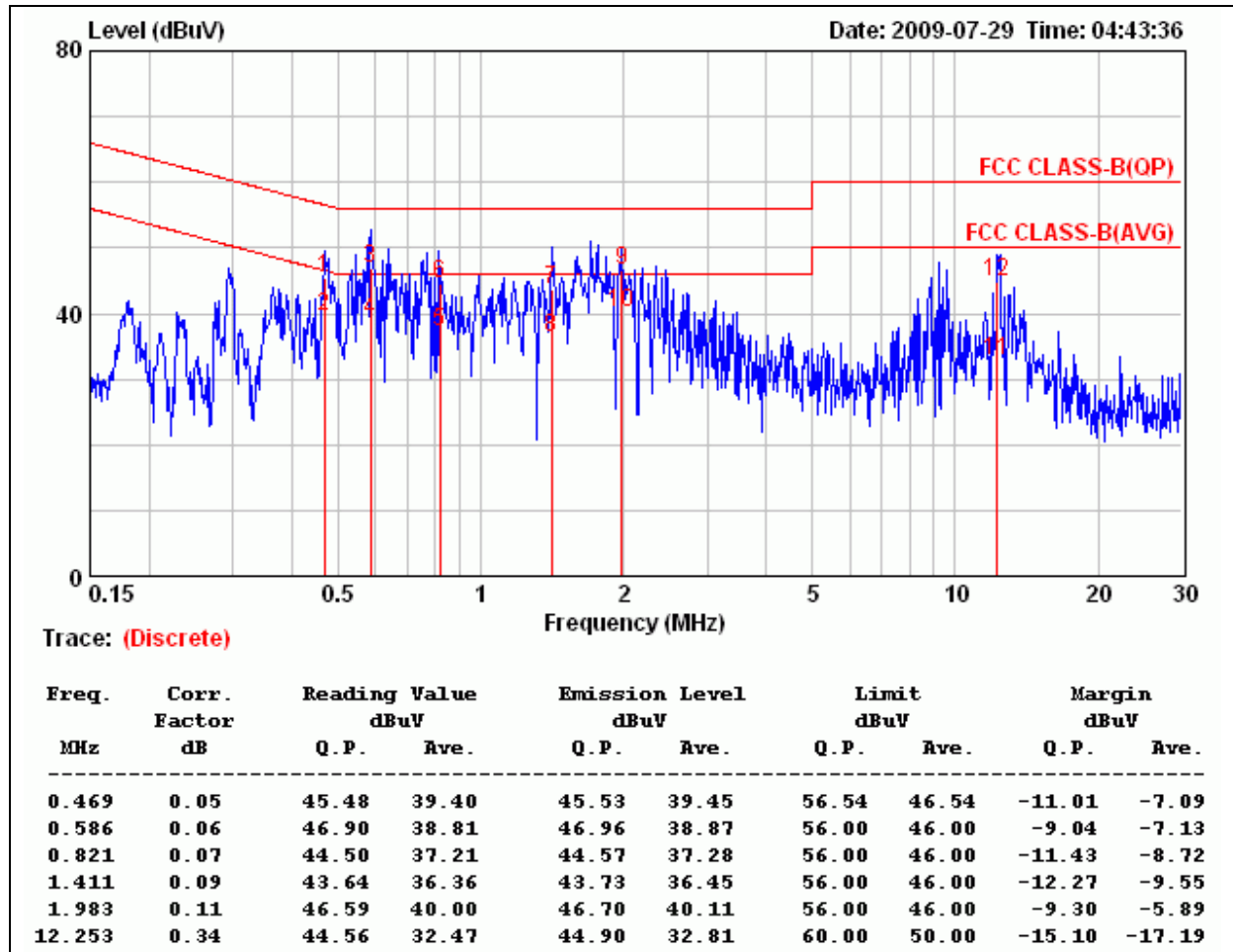
**Remark:**

1. Correction Factor = Insertion loss + cable loss
2. Margin value = Emission level - Limit value