



# FCC TEST REPORT (15.407)

**REPORT NO.:** RF970520L25-1

**MODEL NO.:** DGL-4500

**RECEIVED:** May 20, 2008

**TESTED:** May 26 ~ Jun. 12, 2008

**ISSUED:** Jun. 19, 2008

**APPLICANT:** D-Link Corporation

**ADDRESS:** 17595 Mt. Herrmann, Fountain Valley, CA  
92708, U.S.A.

**ISSUED BY:** Advance Data Technology Corporation

**LAB ADDRESS:** No.47, 14<sup>th</sup> Ling, Chia Pau Tsuen, Linko Hsiang  
244, Taipei Hsien, Taiwan, R.O.C.

**TEST LOCATION:** No. 19, Hwa Ya 2<sup>nd</sup> Rd, Wen Hwa Tsuen, Kwei  
Shan Hsiang, Taoyuan Hsien 333, Taiwan,  
R.O.C.

This test report consists of 100 pages in total. It may be duplicated completely for legal use with the approval of the applicant. It should not be reproduced except in full, without the written approval of our laboratory. The client should not use it to claim product endorsement by TAF, A2LA or any government agencies. The test results in the report only apply to the tested sample.





## TABLE OF CONTENTS

|       |   |    |
|-------|---|----|
| 1.    | CERTIFICATION .....   | 4  |
| 2.    | SUMMARY OF TEST RESULTS.....                                  | 5  |
| 2.1   | MEASUREMENT UNCERTAINTY .....                                 | 5  |
| 3.    | GENERAL INFORMATION .....                                     | 6  |
| 3.1   | GENERAL DESCRIPTION OF EUT .....                              | 6  |
| 3.2   | DESCRIPTION OF TEST MODES .....                               | 8  |
| 3.2.1 | CONFIGURATION OF SYSTEM UNDER TEST.....                       | 8  |
| 3.2.2 | TEST MODE APPLICABILITY AND TESTED CHANNEL DETAIL .....       | 9  |
| 3.3   | GENERAL DESCRIPTION OF APPLIED STANDARDS.....                 | 11 |
| 3.4   | DESCRIPTION OF SUPPORT UNITS.....                             | 11 |
| 4.    | TEST TYPES AND RESULTS.....                                   | 12 |
| 4.1   | RADIATED EMISSION MEASUREMENT .....                           | 12 |
| 4.1.1 | LIMITS OF RADIATED EMISSION MEASUREMENT .....                 | 12 |
| 4.1.2 | LIMITS OF UNWANTED EMISSION OUT OF THE RESTRICTED BANDS ..... | 12 |
| 4.1.3 | TEST INSTRUMENTS .....  | 13 |
| 4.1.4 | TEST PROCEDURES.....  | 14 |
| 4.1.5 | DEVIATION FROM TEST STANDARD .....                            | 14 |
| 4.1.6 | TEST SETUP .....  | 15 |
| 4.1.7 | EUT OPERATING CONDITION .....                                 | 15 |
| 4.1.8 | TEST RESULTS.....   | 16 |
| 4.2   | CONDUCTED EMISSION MEASUREMENT.....                           | 25 |
| 4.2.1 | LIMITS OF CONDUCTED EMISSION MEASUREMENT .....                | 25 |
| 4.2.2 | TEST INSTRUMENTS .....  | 25 |
| 4.2.3 | TEST PROCEDURES.....  | 26 |
| 4.2.4 | DEVIATION FROM TEST STANDARD .....                            | 26 |
| 4.2.5 | TEST SETUP .....  | 27 |
| 4.2.6 | EUT OPERATING CONDITIONS.....                                 | 27 |
| 4.2.7 | TEST RESULTS.....   | 28 |
| 4.3   | PEAK TRANSMIT POWER MEASUREMENT.....                          | 30 |
| 4.3.1 | LIMITS OF PEAK TRANSMIT POWER MEASUREMENT .....               | 30 |
| 4.3.2 | TEST INSTRUMENTS .....  | 30 |
| 4.3.3 | TEST PROCEDURE .....  | 30 |
| 4.3.4 | DEVIATION FROM TEST STANDARD .....                            | 31 |
| 4.3.5 | TEST SETUP .....  | 31 |
| 4.3.6 | EUT OPERATING CONDITIONS.....                                 | 31 |
| 4.3.7 | TEST RESULTS.....   | 32 |
| 4.4   | PEAK POWER EXCURSION MEASUREMENT.....                         | 54 |
| 4.4.1 | LIMITS OF PEAK POWER EXCURSION MEASUREMENT .....              | 54 |
| 4.4.2 | TEST INSTRUMENTS .....  | 54 |
| 4.4.3 | TEST PROCEDURE .....  | 54 |
| 4.4.4 | DEVIATION FROM TEST STANDARD .....                            | 55 |
| 4.4.5 | TEST SETUP .....  | 55 |
| 4.4.6 | EUT OPERATING CONDITIONS.....                                 | 55 |
| 4.4.7 | TEST RESULTS.....   | 56 |
| 4.5   | PEAK POWER SPECTRAL DENSITY MEASUREMENT.....                  | 67 |
| 4.5.1 | LIMITS OF PEAK POWER SPECTRAL DENSITY MEASUREMENT .....       | 67 |
| 4.5.2 | TEST INSTRUMENTS .....  | 67 |
| 4.5.3 | TEST PROCEDURES.....  | 67 |



|       |  |     |
|-------|--|-----|
| 4.5.4 | DEVIATION FROM TEST STANDARD .....   | 68  |
| 4.5.5 | TEST SETUP .....   | 68  |
| 4.5.6 | EUT OPERATING CONDITIONS.....  | 68  |
| 4.5.7 | TEST RESULTS.....  | 69  |
| 4.6   | FREQUENCY STABILITY .....  | 80  |
| 4.6.1 | LIMITS OF FREQUENCY STABILITY MEASUREMENT .....  | 80  |
| 4.6.2 | TEST INSTRUMENTS .....   | 80  |
| 4.6.3 | TEST PROCEDURE .....   | 80  |
| 4.6.4 | DEVIATION FROM TEST STANDARD.....  | 81  |
| 4.6.5 | TEST SETUP .....   | 81  |
| 4.6.6 | EUT OPERATING CONDITION .....  | 81  |
| 4.6.7 | TEST RESULTS.....  | 82  |
| 4.7   | BAND EDGES MEASUREMENT .....   | 83  |
| 4.7.1 | TEST INSTRUMENTS .....   | 83  |
| 4.7.2 | TEST PROCEDURE .....   | 84  |
| 4.7.3 | EUT OPERATING CONDITION .....  | 84  |
| 4.7.4 | TEST RESULTS.....  | 85  |
| 4.8   | ANTENNA REQUIREMENT.....   | 97  |
| 4.8.1 | STANDARD APPLICABLE.....   | 97  |
| 4.8.2 | ANTENNA CONNECTED CONSTRUCTION .....   | 97  |
| 5.    | PHOTOGRAPHS OF THE TEST CONFIGURATION .....  | 98  |
| 6.    | INFORMATION ON THE TESTING LABORATORIES.....   | 99  |
| 7.    | APPENDIX A - MODIFICATIONS RECORDERS FOR ENGINEERING<br>CHANGES TO THE EUT BY THE LAB..... | 100 |



## 1. CERTIFICATION

**PRODUCT:** Xtreme N GAMING ROUTER

**MODEL:** DGL-4500

**BRAND:** D-Link

**APPLICANT:** D-Link Corporation

**TEST SAMPLE:** ENGINEERING SAMPLE

**TESTED:** May 26 ~ Jun. 12, 2008

**STANDARDS: FCC Part 15, Subpart E (Section 15.407)**  
ANSI C63.4-2003

The above equipment (Model: DGL-4500) has been tested by **Advance Data Technology Corporation**, and found compliance with the requirement of the above standards. The test record, data evaluation & Equipment Under Test (EUT) configurations represented herein are true and accurate accounts of the measurements of the sample's EMC characteristics under the conditions specified in this report.

**PREPARED BY** : Andrea Hsia , **DATE:** Jun. 19, 2008  
Andrea Hsia / Specialist

**TECHNICAL ACCEPTANCE** : Long Chen , **DATE:** Jun. 19, 2008  
Responsible for RF Long Chen / Senior Engineer

**APPROVED BY** : Gary Chang , **DATE:** Jun. 19, 2008  
Gary Chang / Assistant Manager

## 2. SUMMARY OF TEST RESULTS

The EUT has been tested according to the following specifications:

| APPLIED STANDARD: FCC PART 15, SUBPART E (SECTION 15.407) |   |        |  |
|---|---|--------|--|
| STANDARD SECTION  | TEST TYPE AND LIMIT   | RESULT | REMARK   |
| 15.407(b)(5)  | AC Power Conducted Emission                                     | PASS   | Meet the requirement of limit. Minimum passing margin is -12.05dB at 0.189MHz. |
| 15.407(b)(1/2/3)<br>(b)(5)                                | Electric Field Strength Spurious Emissions,<br>30MHz ~ 40000MHz | PASS   | Meet the requirement of limit. Minimum passing margin is -1.25dB at 249.60MHz. |
| 15.407(a)(1/2/3)  | Peak Transmit Power   | PASS   | Meet the requirement of limit.   |
| 15.407(a)(6)  | Peak Power Excursion  | PASS   | Meet the requirement of limit.   |
| 15.407(a)(1/2/3)  | Peak Power Spectral Density                                     | PASS   | Meet the requirement of limit.   |
| 15.407(g)   | Frequency Stability   | PASS   | Meet the requirement of limit.   |

### 2.1 MEASUREMENT UNCERTAINTY

Where relevant, the following measurement uncertainty levels have been estimated for tests performed on the EUT as specified in CISPR 16-4-2:

| MEASUREMENT         | FREQUENCY       | UNCERTAINTY |
|---------------------|-----------------|-------------|
| Conducted emissions | 9kHz~30MHz      | 2.44 dB     |
| Radiated emissions  | 30MHz ~ 200MHz  | 2.93 dB     |
|                     | 200MHz ~1000MHz | 2.95 dB     |
|                     | 1GHz ~ 18GHz    | 2.26 dB     |
|                     | 18GHz ~ 40GHz   | 1.94 dB     |

This uncertainty represents an expanded uncertainty expressed at approximately the 95% confidence level using a coverage factor of  $k = 2$ .

### 3. GENERAL INFORMATION

#### 3.1 GENERAL DESCRIPTION OF EUT

|                              |   |
|------------------------------|---|
| <b>PRODUCT</b>               | Xtreme N GAMING ROUTER  |
| <b>MODEL NO.</b>             | DGL-4500  |
| <b>FCC ID</b>                | KA2DGL4500A2  |
| <b>POWER SUPPLY</b>          | 12Vdc from AC adapter   |
| <b>MODULATION TYPE</b>       | CCK, DQPSK, DBPSK for DSSS<br>64QAM, 16QAM, QPSK, BPSK for OFDM   |
| <b>MODULATION TECHNOLOGY</b> | DSSS, OFDM  |
| <b>TRANSFER RATE</b>         | 802.11b:11.0/ 5.5/ 2.0/ 1.0Mbps<br>802.11g: 54.0/ 48.0/ 36.0/ 24.0/ 18.0/ 12.0/ 9.0/ 6.0Mbps<br>802.11a: 54.0/ 48.0/ 36.0/ 24.0/ 18.0/ 12.0/ 9.0/ 6.0Mbps<br>Draft 802.11n: up to 300.0Mbps |
| <b>FREQUENCY RANGE</b>       | 2.4GHz: 2400.0 ~ 2483.5MHz<br>5.0GHz: 5150.0 ~ 5250.0MHz, 5725.0 ~ 5850.0MHz  |
| <b>NUMBER OF CHANNEL</b>     | 2.4GHz:<br>11 for 802.11b, 802.11g, draft 802.11n (20MHz)<br>7 for draft 802.11n (40MHz)<br>5.0GHz:<br>9 for 802.11a, draft 802.11n (20MHz)<br>4 for draft 802.11n (40MHz)                  |
| <b>OUTPUT POWER</b>          | 68.051mW for 2400.0 ~ 2483.5MHz<br>39.771mW for 5150.0 ~ 5250.0MHz<br>72.325mW for 5725.0 ~ 5850.0MHz   |
| <b>ANTENNA TYPE</b>          | 2.4GHz: Dipole antenna with 2.0dBi gain<br>5.0GHz: Dipole antenna with 2.0dBi gain  |
| <b>DATA CABLE</b>            | NA  |
| <b>I/O PORTS</b>             | RJ45  |
| <b>ASSOCIATED DEVICES</b>    | Adapter   |

**NOTE:**

- The EUT is an Xtreme N GAMING ROUTER. The functions of EUT listed as below:

|  | TEST STANDARD                              | REFERENCE REPORT |
|--|--|------------------|
| WLAN 802.11b/g, draft 802.11n                  | FCC Part 15, Subpart C<br>(Section 15.247) | RF970520L25      |
| WLAN 802.11a, draft 802.11n<br>(5725~5850 MHz) |  |                  |
| WLAN 802.11a, draft 802.11n<br>(5150~ 5250MHz) | FCC Part 15, Subpart E<br>(Section 15.407) | RF970520L25-1    |

2. The frequency bands used in this EUT are listed as follows:

| Frequency Band (MHz)  | 2400~2483.5 | 5150~5250 | 5725~5850 |
|-----------------------|-------------|-----------|-----------|
| 802.11b               | √           |           |           |
| 802.11g               | √           |           |           |
| 802.11a               |             | √         | √         |
| Draft 802.11n (20MHz) | √           | √         | √         |
| Draft 802.11n (40MHz) | √           | √         | √         |

3. The EUT was powered by the following adapter:

|                    |                                      |
|--------------------|--------------------------------------|
| <b>BRAND:</b>      | D-Link                               |
| <b>MODEL:</b>      | AG2412-B                             |
| <b>INPUT:</b>      | 100-240Vac, 50-60Hz, 0.5A            |
| <b>OUTPUT:</b>     | 12Vdc, 2A                            |
| <b>POWER LINE:</b> | 1.8m non-shielded cable without core |

4. The EUT incorporates a MIMO function. Physically, the EUT provides three completed transmitters and three receivers.

| MODULATION MODE       | TX FUNCTION |
|-----------------------|-------------|
| 802.11b               | 1TX         |
| 802.11g               | 1TX         |
| 802.11a               | 1TX         |
| Draft 802.11n (20MHz) | 3TX         |
| Draft 802.11n (40MHz) | 3TX         |

5. The above EUT information was declared by manufacturer and for more detailed features description, please refer to the manufacturer's specifications or user's manual.

### 3.2 DESCRIPTION OF TEST MODES

4 channels are provided for 802.11a, draft 802.11n (20MHz):

| CHANNEL | FREQUENCY | CHANNEL | FREQUENCY |
|---------|-----------|---------|-----------|
| 36      | 5180MHz   | 44      | 5220MHz   |
| 40      | 5200MHz   | 48      | 5240MHz   |

2 channels are provided for draft 802.11n (40MHz):

| CHANNEL | FREQUENCY | CHANNEL | FREQUENCY |
|---------|-----------|---------|-----------|
| 38      | 5190MHz   | 46      | 5230MHz   |

#### 3.2.1 CONFIGURATION OF SYSTEM UNDER TEST

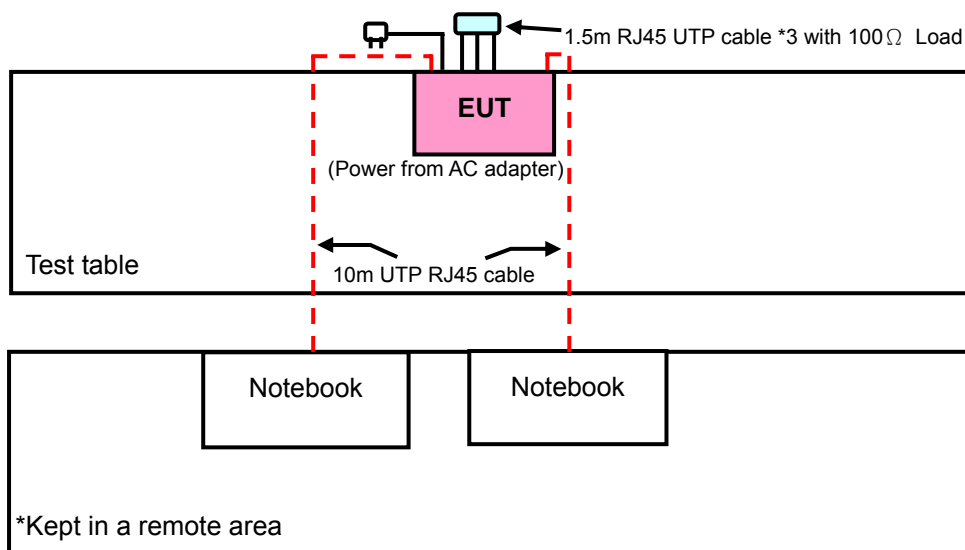



### 3.2.2 TEST MODE APPLICABILITY AND TESTED CHANNEL DETAIL

| EUT CONFIGURE MODE | APPLICABLE TO |       |     |      | DESCRIPTION |
|--------------------|---------------|-------|-----|------|-------------|
|                    | RE $\geq$ 1G  | RE<1G | PLC | APCM |             |
| -                  | √             | √     | √   | √    | -           |

Where **RE $\geq$ 1G**: Radiated Emission above 1GHz      **RE<1G**: Radiated Emission below 1GHz  
**PLC**: Power Line Conducted Emission      **APCM**: Antenna Port Conducted Measurement

#### RADIATED EMISSION TEST (ABOVE 1GHz):

- Pre-Scan has been conducted to determine the worst-case mode from all possible combinations between available modulations, data rates and antenna ports (if EUT with antenna diversity architecture).
- Following channel(s) was (were) selected for the final test as listed below.

| MODE                  | AVAILABLE CHANNEL | TESTED CHANNEL | MODULATION TECHNOLOGY | MODULATION TYPE | DATA RATE (Mbps) |
|-----------------------|-------------------|----------------|-----------------------|-----------------|------------------|
| 802.11a               | 36 to 48          | 36, 40, 48     | OFDM                  | BPSK            | 6.0              |
| Draft 802.11n (20MHz) | 36 to 48          | 36, 40, 48     | OFDM                  | BPSK            | 7.2              |
| Draft 802.11n (40MHz) | 38 to 46          | 38, 46         | OFDM                  | BPSK            | 15.0             |

#### RADIATED EMISSION TEST (BELOW 1GHz):

- Pre-Scan has been conducted to determine the worst-case mode from all possible combinations between available modulations, data rates and antenna ports (if EUT with antenna diversity architecture).
- Following channel(s) was (were) selected for the final test as listed below.

| MODE                  | AVAILABLE CHANNEL | TESTED CHANNEL | MODULATION TECHNOLOGY | MODULATION TYPE | DATA RATE (Mbps) |
|-----------------------|-------------------|----------------|-----------------------|-----------------|------------------|
| Draft 802.11n (20MHz) | 38 to 46          | 36             | OFDM                  | BPSK            | 7.2              |

#### POWER LINE CONDUCTED EMISSION TEST:

- Pre-Scan has been conducted to determine the worst-case mode from all possible combinations between available modulations, data rates and antenna ports (if EUT with antenna diversity architecture).
- Following channel(s) was (were) selected for the final test as listed below.

| MODE                  | AVAILABLE CHANNEL | TESTED CHANNEL | MODULATION TECHNOLOGY | MODULATION TYPE | DATA RATE (Mbps) |
|-----------------------|-------------------|----------------|-----------------------|-----------------|------------------|
| Draft 802.11n (20MHz) | 38 to 46          | 36             | OFDM                  | BPSK            | 7.2              |

**BANDEDGE MEASUREMENT:**

- Pre-Scan has been conducted to determine the worst-case mode from all possible combinations between available modulations, data rates and antenna ports (if EUT with antenna diversity architecture).
- Following channel(s) was (were) selected for the final test as listed below.

| MODE                  | AVAILABLE CHANNEL | TESTED CHANNEL | MODULATION TECHNOLOGY | MODULATION TYPE | DATA RATE (Mbps) |
|-----------------------|-------------------|----------------|-----------------------|-----------------|------------------|
| 802.11a               | 36 to 48          | 36, 48         | OFDM                  | BPSK            | 6.0              |
| Draft 802.11n (20MHz) | 36 to 48          | 36, 48         | OFDM                  | BPSK            | 7.2              |
| Draft 802.11n (40MHz) | 38 to 46          | 38, 46         | OFDM                  | BPSK            | 15.0             |

**ANTENNA PORT CONDUCTED MEASUREMENT:**

- Pre-Scan has been conducted to determine the worst-case mode from all possible combinations between available modulations, data rates and antenna ports (if EUT with antenna diversity architecture).
- Following channel(s) was (were) selected for the final test as listed below.

| MODE                  | AVAILABLE CHANNEL | TESTED CHANNEL | MODULATION TECHNOLOGY | MODULATION TYPE | DATA RATE (Mbps) |
|-----------------------|-------------------|----------------|-----------------------|-----------------|------------------|
| 802.11a               | 36 to 48          | 36, 40, 48     | OFDM                  | BPSK            | 6.0              |
| Draft 802.11n (20MHz) | 36 to 48          | 36, 40, 48     | OFDM                  | BPSK            | 7.2              |
| Draft 802.11n (40MHz) | 38 to 46          | 38, 46         | OFDM                  | BPSK            | 15.0             |



### 3.3 GENERAL DESCRIPTION OF APPLIED STANDARDS

The EUT is a RF Product. According to the specifications of the manufacturer, it must comply with the requirements of the following standards:

**FCC Part 15, Subpart E (15.407)**

**ANSI C63.4-2003**

All test items have been performed and recorded as per the above standards.

**NOTE:** The EUT is also considered as a kind of computer peripheral, because the connection to computer is necessary for typical use. It has been verified to comply with the requirements of FCC Part 15, Subpart B, Class B (DoC). The test report has been issued separately.

### 3.4 DESCRIPTION OF SUPPORT UNITS

The EUT has been tested as an independent unit together with other necessary accessories or support units. The following support units or accessories were used to form a representative test configuration during the tests.

| NO. | PRODUCT           | BRAND | MODEL NO. | SERIAL NO.  | FCC ID    |
|-----|-------------------|-------|-----------|-------------|-----------|
| 1   | NOTEBOOK COMPUTER | DELL  | PP05L     | 16484462992 | E2K24CLNS |
| 2   | NOTEBOOK COMPUTER | DELL  | PP05L     | 12130898320 | E2K24CLNS |

| NO. | SIGNAL CABLE DESCRIPTION OF THE ABOVE SUPPORT UNITS |
|-----|---|
| 1   | 10m UTP RJ 45 cable                                 |
| 2   | 10m UTP RJ 45 cable                                 |

**NOTE 1:** All power cords of the above support units are non shielded (1.8m).

**NOTE 2:** Item 1 ~ 2 acted as communication partners to transfer data.

## 4. TEST TYPES AND RESULTS

### 4.1 RADIATED EMISSION MEASUREMENT

#### 4.1.1 LIMITS OF RADIATED EMISSION MEASUREMENT

Emissions radiated outside of the specified bands, shall be according to the general radiated limits in 15.209 as following:

| FREQUENCIES (MHz) | FIELD STRENGTH (microvolts/meter) | MEASUREMENT DISTANCE (meters) |
|-------------------|-----------------------------------|-------------------------------|
| 0.009 ~ 0.490     | 2400/F(kHz)                       | 300                           |
| 0.490 ~ 1.705     | 24000/F(kHz)                      | 30                            |
| 1.705 ~ 30.0      | 30                                | 30                            |
| 30 ~ 88           | 100                               | 3                             |
| 88 ~ 216          | 150                               | 3                             |
| 216 ~ 960         | 200                               | 3                             |
| Above 960         | 500                               | 3                             |

**NOTE:**

1. The lower limit shall apply at the transition frequencies.
2. Emission level (dBuV/m) = 20 log Emission level (uV/m).
3. As shown in 15.35(b), for frequencies above 1000MHz, the field strength limits are based on average detector, however, the peak field strength of any emission shall not exceed the maximum permitted average limits, specified above by more than 20dB under any condition of modulation.

#### 4.1.2 LIMITS OF UNWANTED EMISSION OUT OF THE RESTRICTED BANDS

| FREQUENCIES (MHz) | EIRP LIMIT (dBm) |     | EQUIVALENT FIELD STRENGTH AT 3m (dBµV/m) *NOTE 3 |      |
|-------------------|------------------|-----|--|------|
|                   | PK               | AV  | PK   | AV   |
| 5150 ~ 5250       | -7               | -27 | 88.3   | 68.3 |

**NOTE:**

1. For frequencies 10MHz or greater above or below the band edge.
2. All emissions within the frequency range from the band edge to 10MHz above or below the band edge.
3. The following formula is used to convert the equipment isotropic radiated power (eirp) to field strength:

$$E = \frac{1000000\sqrt{30P}}{3} \mu\text{V/m, where P is the eirp (Watts).}$$



#### 4.1.3 TEST INSTRUMENTS

| DESCRIPTION & MANUFACTURER                    | MODEL NO.         | SERIAL NO.     | CALIBRATED UNTIL |
|---|-------------------|----------------|------------------|
| Test Receiver<br>ROHDE & SCHWARZ              | ESIB7             | 100212         | May. 27, 2009    |
| Spectrum Analyzer<br>ROHDE & SCHWARZ          | FSP40             | 100269         | Aug. 05, 2008    |
| BILOG Antenna<br>SCHWARZBECK                  | VULB9168          | 9168-153       | Jan. 03, 2009    |
| HORN Antenna<br>SCHWARZBECK                   | BBHA 9120 D       | 9120D-563      | Jul. 30, 2008    |
| HORN Antenna<br>SCHWARZBECK                   | BBHA 9170         | BBHA9170242    | Jan. 06, 2009    |
| Preamplifier<br>Agilent                       | 8449B             | 3008A01910     | Sep. 19, 2008    |
| Preamplifier<br>Agilent                       | 8447D             | 2944A10638     | Dec. 19, 2008    |
| RF signal cable<br>HUBER+SUHNNER              | SUCOFLEX 104      | 274039/223650  | Nov. 07, 2008    |
| RF signal cable<br>Worken                     | 8D-FB             | Cable-HYCH9-01 | Aug. 09, 2008    |
| Software                                      | ADT_Radiated_V7.6 | NA             | NA               |
| Antenna Tower<br>EMCO                         | 2070/2080         | 512.835.4684   | NA               |
| Turn Table<br>EMCO                            | 2087-2.03         | NA             | NA               |
| Antenna Tower & Turn Table<br>Controller EMCO | 2090              | NA             | NA               |
| 26GHz ~ 40GHz Amplifier                       | EM26400           | 07026401       | May 05, 2009     |

- NOTE:**
1. The calibration interval of the above test instruments is 12 months and the calibrations are traceable to NML/ROC and NIST/USA.
  2. The test was performed in HwaYa Chamber 9.
  3. The horn antenna and HP preamplifier (model: 8449B) are used only for the measurement of emission frequency above 1GHz if tested.
  4. The FCC Site Registration No. is 215374.
  5. The IC Site Registration No. is IC3789B-9.

#### 4.1.4 TEST PROCEDURES

- a. The EUT was placed on the top of a rotating table 0.8 meters above the ground at a 3 meter semi-anechoic chamber. The table was rotated 360 degrees to determine the position of the highest radiation.
- b. The EUT was set 3 meters away from the interference-receiving antenna, which was mounted on the top of a variable-height antenna tower.
- c. The antenna is a broadband antenna, and its height is varied from one meter to four meters above the ground to determine the maximum value of the field strength. Both horizontal and vertical polarizations of the antenna are set to make the measurement.
- d. For each suspected emission, the EUT was arranged to its worst case and then the antenna was tuned to heights from 1 meter to 4 meters and the rotatable table was turned from 0 degrees to 360 degrees to find the maximum reading.
- e. The test-receiver system was set to Peak Detect Function and Specified Bandwidth with Maximum Hold Mode.
- f. If the emission level of the EUT in peak mode was 10dB lower than the limit specified, then testing could be stopped and the peak values of the EUT would be reported. Otherwise the emissions that did not have 10dB margin would be re-tested one by one using peak, quasi-peak or average method as specified and then reported in a data sheet.

**NOTE:**

1. The resolution bandwidth and video bandwidth of test receiver/spectrum analyzer is 120kHz for Peak detection (PK) and Quasi-peak detection (QP) at frequency below 1GHz.
2. The resolution bandwidth of test receiver/spectrum analyzer is 1MHz and video bandwidth is 3MHz for Peak detection at frequency above 1GHz.
3. The resolution bandwidth of test receiver/spectrum analyzer is 1MHz and the video bandwidth is 10Hz for Average detection (AV) at frequency above 1GHz.
4. All modes of operation were investigated and the worst-case emissions are reported.

#### 4.1.5 DEVIATION FROM TEST STANDARD

No deviation

#### 4.1.6 TEST SETUP

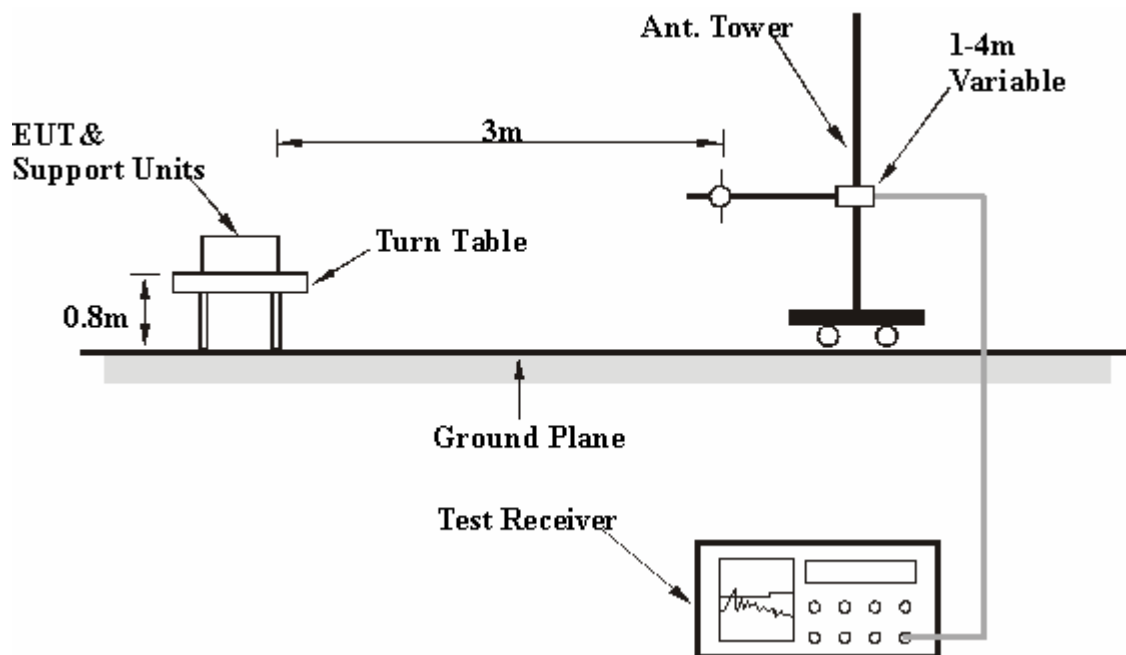

For the actual test configuration, please refer to the attached file (Test Setup Photo).

#### 4.1.7 EUT OPERATING CONDITION

- a. Placed the EUT on a testing table.
- b. Prepared notebook computer and placed it outside of testing area to act as communication partner for EUT.
- c. The EUT ran a test program (provided by manufacturer) to enable all functions under transmission condition continuously at specific channel frequency.
- d. The necessary accessories enable the EUT in full functions.

#### 4.1.8 TEST RESULTS

##### 802.11a OFDM MODULATION

| EUT TEST CONDITION       |                           | MEASUREMENT DETAIL |                           |
|--------------------------|---------------------------|--------------------|---------------------------|
| CHANNEL                  | Channel 36                | FREQUENCY RANGE    | 1 ~ 40GHz                 |
| INPUT POWER (SYSTEM)     | 120Vac, 60 Hz             | DETECTOR FUNCTION  | Peak (PK)<br>Average (AV) |
| ENVIRONMENTAL CONDITIONS | 23deg. C, 68%RH<br>999hPa | TESTED BY          | Mitch Tsui                |

| ANTENNA POLARITY & TEST DISTANCE: HORIZONTAL AT 3 M |             |                         |                |             |                    |                      |                  |                          |
|---|-------------|-------------------------|----------------|-------------|--------------------|----------------------|------------------|--------------------------|
| NO.   | FREQ. (MHz) | EMISSION LEVEL (dBuV/m) | LIMIT (dBuV/m) | MARGIN (dB) | ANTENNA HEIGHT (m) | TABLE ANGLE (Degree) | RAW VALUE (dBuV) | CORRECTION FACTOR (dB/m) |
| 1   | 1125.00     | 54.97 PK                | 74.00          | -19.03      | 1.13 H             | 346                  | 26.89            | 28.08                    |
| 2   | 1125.00     | 45.75 AV                | 54.00          | -8.25       | 1.13 H             | 346                  | 17.67            | 28.08                    |
| 3   | 5150.00     | 49.57 PK                | 74.00          | -24.43      | 1.04 H             | 305                  | 10.98            | 38.59                    |
| 4   | 5150.00     | 37.14 AV                | 54.00          | -16.86      | 1.04 H             | 305                  | -1.45            | 38.59                    |
| 5   | *5180.00    | 99.23 PK                |                |             | 1.04 H             | 305                  | 60.59            | 38.64                    |
| 6   | *5180.00    | 88.41 AV                |                |             | 1.04 H             | 305                  | 49.77            | 38.64                    |
| 7   | #10360.00   | 58.08 PK                | 88.30          | -30.22      | 1.00 H             | 360                  | 9.38             | 48.70                    |
| 8   | #10360.00   | 44.27 AV                | 68.30          | -24.03      | 1.00 H             | 360                  | -4.43            | 48.70                    |
| ANTENNA POLARITY & TEST DISTANCE: VERTICAL AT 3 M   |             |                         |                |             |                    |                      |                  |                          |
| NO.   | FREQ. (MHz) | EMISSION LEVEL (dBuV/m) | LIMIT (dBuV/m) | MARGIN (dB) | ANTENNA HEIGHT (m) | TABLE ANGLE (Degree) | RAW VALUE (dBuV) | CORRECTION FACTOR (dB/m) |
| 1   | 1125.00     | 57.58 PK                | 74.00          | -16.42      | 1.41 V             | 356                  | 29.50            | 28.08                    |
| 2   | 1125.00     | 51.30 AV                | 54.00          | -2.70       | 1.41 V             | 356                  | 23.22            | 28.08                    |
| 3   | 5150.00     | 57.72 PK                | 74.00          | -16.28      | 1.05 V             | 342                  | 19.13            | 38.59                    |
| 4   | 5150.00     | 41.68 AV                | 54.00          | -12.32      | 1.05 V             | 342                  | 3.09             | 38.59                    |
| 5   | *5180.00    | 111.21 PK               |                |             | 1.05 V             | 342                  | 72.57            | 38.64                    |
| 6   | *5180.00    | 99.98 AV                |                |             | 1.05 V             | 342                  | 61.34            | 38.64                    |
| 7   | #10360.00   | 57.53 PK                | 88.30          | -30.77      | 1.00 V             | 0                    | 8.83             | 48.70                    |
| 8   | #10360.00   | 44.50 AV                | 68.30          | -23.80      | 1.00 V             | 0                    | -4.20            | 48.70                    |

- REMARKS:**
1. Emission level (dBuV/m) = Raw Value (dBuV) + Correction Factor (dB/m).
  2. Correction Factor (dB/m) = Antenna Factor (dB/m) + Cable Factor (dB).
  3. The other emission levels were very low against the limit.
  4. Margin value = Emission level – Limit value.
  5. “ \* “: Fundamental frequency.
  6. “#“: The radiated frequency is out the restricted band.



| EUT TEST CONDITION       |                           | MEASUREMENT DETAIL |                           |
|--------------------------|---------------------------|--------------------|---------------------------|
| CHANNEL                  | Channel 40                | FREQUENCY RANGE    | 1 ~ 40GHz                 |
| INPUT POWER (SYSTEM)     | 120Vac, 60 Hz             | DETECTOR FUNCTION  | Peak (PK)<br>Average (AV) |
| ENVIRONMENTAL CONDITIONS | 23deg. C, 68%RH<br>999hPa | TESTED BY          | Mitch Tsui                |

| ANTENNA POLARITY & TEST DISTANCE: HORIZONTAL AT 3 M |             |                         |                |             |                    |                      |                  |                          |
|---|-------------|-------------------------|----------------|-------------|--------------------|----------------------|------------------|--------------------------|
| NO.   | FREQ. (MHz) | EMISSION LEVEL (dBuV/m) | LIMIT (dBuV/m) | MARGIN (dB) | ANTENNA HEIGHT (m) | TABLE ANGLE (Degree) | RAW VALUE (dBuV) | CORRECTION FACTOR (dB/m) |
| 1   | 1125.00     | 55.06 PK                | 74.00          | -18.94      | 1.17 H             | 356                  | 26.98            | 28.08                    |
| 2   | 1125.00     | 46.08 AV                | 54.00          | -7.92       | 1.17 H             | 356                  | 18.00            | 28.08                    |
| 3   | *5200.00    | 99.95 PK                |                |             | 1.06 H             | 310                  | 61.28            | 38.67                    |
| 4   | *5200.00    | 88.16 AV                |                |             | 1.06 H             | 310                  | 49.49            | 38.67                    |
| 5   | #10400.00   | 57.85 PK                | 88.30          | -30.45      | 1.00 H             | 0                    | 9.08             | 48.77                    |
| 6   | #10400.00   | 44.31 AV                | 68.30          | -23.99      | 1.00 H             | 0                    | -4.46            | 48.77                    |
| ANTENNA POLARITY & TEST DISTANCE: VERTICAL AT 3 M   |             |                         |                |             |                    |                      |                  |                          |
| NO.   | FREQ. (MHz) | EMISSION LEVEL (dBuV/m) | LIMIT (dBuV/m) | MARGIN (dB) | ANTENNA HEIGHT (m) | TABLE ANGLE (Degree) | RAW VALUE (dBuV) | CORRECTION FACTOR (dB/m) |
| 1   | 1125.00     | 57.62 PK                | 74.00          | -16.38      | 1.39 V             | 354                  | 29.54            | 28.08                    |
| 2   | 1125.00     | 51.21 AV                | 54.00          | -2.79       | 1.39 V             | 354                  | 23.13            | 28.08                    |
| 3   | *5200.00    | 111.04 PK               |                |             | 1.07 V             | 355                  | 72.37            | 38.67                    |
| 4   | *5200.00    | 100.24 AV               |                |             | 1.07 V             | 355                  | 61.57            | 38.67                    |
| 5   | #10400.00   | 57.96 PK                | 88.30          | -30.34      | 1.00 V             | 360                  | 9.19             | 48.77                    |
| 6   | #10400.00   | 44.69 AV                | 68.30          | -23.61      | 1.00 V             | 360                  | -4.08            | 48.77                    |

- REMARKS:**
1. Emission level (dBuV/m) = Raw Value (dBuV) + Correction Factor (dB/m).
  2. Correction Factor (dB/m) = Antenna Factor (dB/m) + Cable Factor (dB).
  3. The other emission levels were very low against the limit.
  4. Margin value = Emission level – Limit value.
  5. “ \* “: Fundamental frequency.
  6. “#”: The radiated frequency is out the restricted band.

| EUT TEST CONDITION       |                           | MEASUREMENT DETAIL |                           |
|--------------------------|---------------------------|--------------------|---------------------------|
| CHANNEL                  | Channel 48                | FREQUENCY RANGE    | 1 ~ 40GHz                 |
| INPUT POWER (SYSTEM)     | 120Vac, 60 Hz             | DETECTOR FUNCTION  | Peak (PK)<br>Average (AV) |
| ENVIRONMENTAL CONDITIONS | 23deg. C, 68%RH<br>999hPa | TESTED BY          | Mitch Tsui                |

| ANTENNA POLARITY & TEST DISTANCE: HORIZONTAL AT 3 M |             |                         |                |             |                    |                      |                  |                          |
|---|-------------|-------------------------|----------------|-------------|--------------------|----------------------|------------------|--------------------------|
| NO.   | FREQ. (MHz) | EMISSION LEVEL (dBuV/m) | LIMIT (dBuV/m) | MARGIN (dB) | ANTENNA HEIGHT (m) | TABLE ANGLE (Degree) | RAW VALUE (dBuV) | CORRECTION FACTOR (dB/m) |
| 1   | 1125.00     | 53.54 PK                | 74.00          | -20.46      | 1.07 H             | 341                  | 25.46            | 28.08                    |
| 2   | 1125.00     | 44.86 AV                | 54.00          | -9.14       | 1.07 H             | 341                  | 16.78            | 28.08                    |
| 3   | *5240.00    | 99.31 PK                |                |             | 1.09 H             | 311                  | 60.60            | 38.71                    |
| 4   | *5240.00    | 88.81 AV                |                |             | 1.09 H             | 311                  | 50.10            | 38.71                    |
| 5   | 5350.00     | 58.49 PK                | 74.00          | -15.51      | 1.09 H             | 311                  | 19.68            | 38.81                    |
| 6   | 5350.00     | 44.27 AV                | 54.00          | -9.73       | 1.09 H             | 311                  | 5.46             | 38.81                    |
| 7   | #10480.00   | 57.98 PK                | 88.30          | -30.32      | 1.00 H             | 360                  | 8.97             | 49.01                    |
| 8   | #10480.00   | 44.62 AV                | 68.30          | -23.68      | 1.00 H             | 360                  | -4.39            | 49.01                    |
| ANTENNA POLARITY & TEST DISTANCE: VERTICAL AT 3 M   |             |                         |                |             |                    |                      |                  |                          |
| NO.   | FREQ. (MHz) | EMISSION LEVEL (dBuV/m) | LIMIT (dBuV/m) | MARGIN (dB) | ANTENNA HEIGHT (m) | TABLE ANGLE (Degree) | RAW VALUE (dBuV) | CORRECTION FACTOR (dB/m) |
| 1   | 1125.00     | 58.21 PK                | 74.00          | -15.79      | 1.04 V             | 354                  | 30.13            | 28.08                    |
| 2   | 1125.00     | 50.88 AV                | 54.00          | -3.12       | 1.04 V             | 354                  | 22.80            | 28.08                    |
| 3   | *5240.00    | 111.42 PK               |                |             | 1.09 V             | 334                  | 72.71            | 38.71                    |
| 4   | *5240.00    | 100.07 AV               |                |             | 1.09 V             | 334                  | 61.36            | 38.71                    |
| 5   | 5350.00     | 59.33 PK                | 74.00          | -14.67      | 1.09 V             | 334                  | 20.52            | 38.81                    |
| 6   | 5350.00     | 45.65 AV                | 54.00          | -8.35       | 1.09 V             | 334                  | 6.84             | 38.81                    |
| 7   | #10480.00   | 57.69 PK                | 88.30          | -30.61      | 1.11 V             | 360                  | 8.68             | 49.01                    |
| 8   | #10480.00   | 44.41 AV                | 68.30          | -23.89      | 1.11 V             | 360                  | -4.60            | 49.01                    |

- REMARKS:**
1. Emission level (dBuV/m) = Raw Value (dBuV) + Correction Factor (dB/m).
  2. Correction Factor (dB/m) = Antenna Factor (dB/m) + Cable Factor (dB).
  3. The other emission levels were very low against the limit.
  4. Margin value = Emission level – Limit value.
  5. “ \* “: Fundamental frequency.
  6. “#”: The radiated frequency is out the restricted band.



**DRAFT 802.11n (20MHz) OFDM MODULATION**

| EUT TEST CONDITION       |                           | MEASUREMENT DETAIL |                           |
|--------------------------|---------------------------|--------------------|---------------------------|
| CHANNEL                  | Channel 36                | FREQUENCY RANGE    | 1 ~ 40GHz                 |
| INPUT POWER (SYSTEM)     | 120Vac, 60 Hz             | DETECTOR FUNCTION  | Peak (PK)<br>Average (AV) |
| ENVIRONMENTAL CONDITIONS | 24deg. C, 68%RH<br>999hPa | TESTED BY          | Mitch Tsui                |

| ANTENNA POLARITY & TEST DISTANCE: HORIZONTAL AT 3 M |             |                         |                |             |                    |                      |                  |                          |
|---|-------------|-------------------------|----------------|-------------|--------------------|----------------------|------------------|--------------------------|
| NO.   | FREQ. (MHz) | EMISSION LEVEL (dBuV/m) | LIMIT (dBuV/m) | MARGIN (dB) | ANTENNA HEIGHT (m) | TABLE ANGLE (Degree) | RAW VALUE (dBuV) | CORRECTION FACTOR (dB/m) |
| 1   | 5150.00     | 46.85 PK                | 74.00          | -27.15      | 1.08 H             | 216                  | 8.26             | 38.59                    |
| 2   | 5150.00     | 34.13 AV                | 54.00          | -19.87      | 1.08 H             | 216                  | -4.46            | 38.59                    |
| 3   | *5180.00    | 98.26 PK                |                |             | 1.08 H             | 216                  | 59.62            | 38.64                    |
| 4   | *5180.00    | 87.85 AV                |                |             | 1.08 H             | 216                  | 49.21            | 38.64                    |
| 5   | #10360.00   | 57.03 PK                | 88.30          | -31.27      | 1.11 H             | 29                   | 8.33             | 48.70                    |
| 6   | #10360.00   | 43.51 AV                | 68.30          | -24.79      | 1.11 H             | 29                   | -5.19            | 48.70                    |

| ANTENNA POLARITY & TEST DISTANCE: VERTICAL AT 3 M |             |                         |                |             |                    |                      |                  |                          |
|---|-------------|-------------------------|----------------|-------------|--------------------|----------------------|------------------|--------------------------|
| NO.   | FREQ. (MHz) | EMISSION LEVEL (dBuV/m) | LIMIT (dBuV/m) | MARGIN (dB) | ANTENNA HEIGHT (m) | TABLE ANGLE (Degree) | RAW VALUE (dBuV) | CORRECTION FACTOR (dB/m) |
| 1   | 1125.00     | 53.81 PK                | 74.00          | -20.19      | 1.01 V             | 14                   | 25.73            | 28.08                    |
| 2   | 1125.00     | 48.62 AV                | 54.00          | -5.38       | 1.01 V             | 14                   | 20.54            | 28.08                    |
| 3   | 5150.00     | 52.28 PK                | 74.00          | -21.72      | 1.04 V             | 159                  | 13.69            | 38.59                    |
| 4   | 5150.00     | 44.00 AV                | 54.00          | -10.00      | 1.04 V             | 159                  | 5.41             | 38.59                    |
| 5   | *5180.00    | 110.69 PK               |                |             | 1.04 V             | 159                  | 72.05            | 38.64                    |
| 6   | *5180.00    | 100.00 AV               |                |             | 1.04 V             | 159                  | 61.36            | 38.64                    |
| 7   | #10360.00   | 57.11 PK                | 88.30          | -31.19      | 1.03 V             | 24                   | 8.41             | 48.70                    |
| 8   | #10360.00   | 43.62 AV                | 68.30          | -24.68      | 1.03 V             | 24                   | -5.08            | 48.70                    |

- REMARKS:**
1. Emission level (dBuV/m) = Raw Value (dBuV) + Correction Factor (dB/m).
  2. Correction Factor (dB/m) = Antenna Factor (dB/m) + Cable Factor (dB).
  3. The other emission levels were very low against the limit.
  4. Margin value = Emission level – Limit value.
  5. “ \* “: Fundamental frequency.
  6. “#”:The radiated frequency is out the restricted band.



| EUT TEST CONDITION       |                           | MEASUREMENT DETAIL |                           |
|--------------------------|---------------------------|--------------------|---------------------------|
| CHANNEL                  | Channel 40                | FREQUENCY RANGE    | 1 ~ 40GHz                 |
| INPUT POWER (SYSTEM)     | 120Vac, 60 Hz             | DETECTOR FUNCTION  | Peak (PK)<br>Average (AV) |
| ENVIRONMENTAL CONDITIONS | 24deg. C, 68%RH<br>999hPa | TESTED BY          | Mitch Tsui                |

| ANTENNA POLARITY & TEST DISTANCE: HORIZONTAL AT 3 M |             |                         |                |             |                    |                      |                  |                          |
|---|-------------|-------------------------|----------------|-------------|--------------------|----------------------|------------------|--------------------------|
| NO.   | FREQ. (MHz) | EMISSION LEVEL (dBuV/m) | LIMIT (dBuV/m) | MARGIN (dB) | ANTENNA HEIGHT (m) | TABLE ANGLE (Degree) | RAW VALUE (dBuV) | CORRECTION FACTOR (dB/m) |
| 1   | *5200.00    | 97.95 PK                |                |             | 1.09 H             | 215                  | 59.28            | 38.67                    |
| 2   | *5200.00    | 87.63 AV                |                |             | 1.09 H             | 215                  | 48.96            | 38.67                    |
| 3   | #10400.00   | 57.11 PK                | 88.30          | -31.19      | 1.09 H             | 56                   | 8.34             | 48.77                    |
| 4   | #10400.00   | 43.62 AV                | 68.30          | -24.68      | 1.09 H             | 56                   | -5.15            | 48.77                    |
| ANTENNA POLARITY & TEST DISTANCE: VERTICAL AT 3 M   |             |                         |                |             |                    |                      |                  |                          |
| NO.   | FREQ. (MHz) | EMISSION LEVEL (dBuV/m) | LIMIT (dBuV/m) | MARGIN (dB) | ANTENNA HEIGHT (m) | TABLE ANGLE (Degree) | RAW VALUE (dBuV) | CORRECTION FACTOR (dB/m) |
| 1   | 1125.00     | 53.66 PK                | 74.00          | -20.34      | 1.09 V             | 56                   | 25.58            | 28.08                    |
| 2   | 1125.00     | 48.42 AV                | 54.00          | -5.58       | 1.09 V             | 56                   | 20.34            | 28.08                    |
| 3   | *5200.00    | 110.53 PK               |                |             | 1.05 V             | 160                  | 71.86            | 38.67                    |
| 4   | *5200.00    | 99.86 AV                |                |             | 1.05 V             | 160                  | 61.19            | 38.67                    |
| 5   | #10400.00   | 57.34 PK                | 88.30          | -30.96      | 1.06 V             | 51                   | 8.57             | 48.77                    |
| 6   | #10400.00   | 43.85 AV                | 68.30          | -24.45      | 1.06 V             | 51                   | -4.92            | 48.77                    |

- REMARKS:**
1. Emission level (dBuV/m) = Raw Value (dBuV) + Correction Factor (dB/m).
  2. Correction Factor (dB/m) = Antenna Factor (dB/m) + Cable Factor (dB).
  3. The other emission levels were very low against the limit.
  4. Margin value = Emission level – Limit value.
  5. “ \* “: Fundamental frequency.
  6. “#”:The radiated frequency is out the restricted band.

| EUT TEST CONDITION       |                           | MEASUREMENT DETAIL |                           |
|--------------------------|---------------------------|--------------------|---------------------------|
| CHANNEL                  | Channel 48                | FREQUENCY RANGE    | 1 ~ 40GHz                 |
| INPUT POWER (SYSTEM)     | 120Vac, 60 Hz             | DETECTOR FUNCTION  | Peak (PK)<br>Average (AV) |
| ENVIRONMENTAL CONDITIONS | 24deg. C, 68%RH<br>999hPa | TESTED BY          | Mitch Tsui                |

| ANTENNA POLARITY & TEST DISTANCE: HORIZONTAL AT 3 M |             |                         |                |             |                    |                      |                  |                          |
|---|-------------|-------------------------|----------------|-------------|--------------------|----------------------|------------------|--------------------------|
| NO.   | FREQ. (MHz) | EMISSION LEVEL (dBuV/m) | LIMIT (dBuV/m) | MARGIN (dB) | ANTENNA HEIGHT (m) | TABLE ANGLE (Degree) | RAW VALUE (dBuV) | CORRECTION FACTOR (dB/m) |
| 1   | *5240.00    | 97.86 PK                |                |             | 1.10 H             | 213                  | 59.15            | 38.71                    |
| 2   | *5240.00    | 87.51 AV                |                |             | 1.10 H             | 213                  | 48.80            | 38.71                    |
| 3   | 5350.00     | 58.32 PK                | 74.00          | -15.68      | 1.10 H             | 213                  | 19.51            | 38.81                    |
| 4   | 5350.00     | 44.09 AV                | 54.00          | -9.91       | 1.10 H             | 213                  | 5.28             | 38.81                    |
| 5   | #10480.00   | 57.26 PK                | 88.30          | -31.04      | 1.01 H             | 66                   | 8.25             | 49.01                    |
| 6   | #10480.00   | 43.81 AV                | 68.30          | -24.49      | 1.01 H             | 66                   | -5.20            | 49.01                    |
| ANTENNA POLARITY & TEST DISTANCE: VERTICAL AT 3 M   |             |                         |                |             |                    |                      |                  |                          |
| NO.   | FREQ. (MHz) | EMISSION LEVEL (dBuV/m) | LIMIT (dBuV/m) | MARGIN (dB) | ANTENNA HEIGHT (m) | TABLE ANGLE (Degree) | RAW VALUE (dBuV) | CORRECTION FACTOR (dB/m) |
| 1   | 1125.00     | 54.12 PK                | 74.00          | -19.88      | 1.02 V             | 23                   | 26.04            | 28.08                    |
| 2   | 1125.00     | 48.96 AV                | 54.00          | -5.04       | 1.02 V             | 23                   | 20.88            | 28.08                    |
| 3   | *5240.00    | 110.41 PK               |                |             | 1.06 V             | 155                  | 71.70            | 38.71                    |
| 4   | *5240.00    | 99.68 AV                |                |             | 1.06 V             | 155                  | 60.97            | 38.71                    |
| 5   | 5350.00     | 59.24 PK                | 74.00          | -14.76      | 1.06 V             | 155                  | 20.43            | 38.81                    |
| 6   | 5350.00     | 45.46 AV                | 54.00          | -8.54       | 1.06 V             | 155                  | 6.65             | 38.81                    |
| 7   | #10480.00   | 58.13 PK                | 88.30          | -30.17      | 1.06 V             | 29                   | 9.12             | 49.01                    |
| 8   | #10480.00   | 43.86 AV                | 68.30          | -24.44      | 1.06 V             | 29                   | -5.15            | 49.01                    |

- REMARKS:**
1. Emission level (dBuV/m) = Raw Value (dBuV) + Correction Factor (dB/m).
  2. Correction Factor (dB/m) = Antenna Factor (dB/m) + Cable Factor (dB).
  3. The other emission levels were very low against the limit.
  4. Margin value = Emission level – Limit value.
  5. “ \* “: Fundamental frequency.
  6. “#”:The radiated frequency is out the restricted band.



**DRAFT 802.11n (40MHz) OFDM MODULATION**

| EUT TEST CONDITION       |                           | MEASUREMENT DETAIL |                           |
|--------------------------|---------------------------|--------------------|---------------------------|
| CHANNEL                  | Channel 38                | FREQUENCY RANGE    | 1 ~ 40GHz                 |
| INPUT POWER (SYSTEM)     | 120Vac, 60 Hz             | DETECTOR FUNCTION  | Peak (PK)<br>Average (AV) |
| ENVIRONMENTAL CONDITIONS | 24deg. C, 68%RH<br>999hPa | TESTED BY          | Mitch Tsui                |

| ANTENNA POLARITY & TEST DISTANCE: HORIZONTAL AT 3 M |             |                         |                |             |                    |                      |                  |                          |
|---|-------------|-------------------------|----------------|-------------|--------------------|----------------------|------------------|--------------------------|
| NO.   | FREQ. (MHz) | EMISSION LEVEL (dBuV/m) | LIMIT (dBuV/m) | MARGIN (dB) | ANTENNA HEIGHT (m) | TABLE ANGLE (Degree) | RAW VALUE (dBuV) | CORRECTION FACTOR (dB/m) |
| 1   | 1125.00     | 54.29 PK                | 74.00          | -19.71      | 1.23 H             | 343                  | 26.21            | 28.08                    |
| 2   | 1125.00     | 45.00 AV                | 54.00          | -9.00       | 1.23 H             | 343                  | 16.92            | 28.08                    |
| 3   | 5150.00     | 55.71 PK                | 74.00          | -18.29      | 1.01 H             | 19                   | 17.12            | 38.59                    |
| 4   | 5150.00     | 41.51 AV                | 54.00          | -12.49      | 1.01 H             | 19                   | 2.92             | 38.59                    |
| 5   | *5190.00    | 98.13 PK                |                |             | 1.01 H             | 19                   | 59.48            | 38.65                    |
| 6   | *5190.00    | 87.87 AV                |                |             | 1.01 H             | 19                   | 49.22            | 38.65                    |
| 7   | #6920.00    | 50.34 PK                | 88.30          | -37.96      | 1.24 H             | 331                  | 7.09             | 43.25                    |
| 8   | #6920.00    | 39.50 AV                | 68.30          | -28.80      | 1.24 H             | 331                  | -3.75            | 43.25                    |
| 9   | #10380.00   | 58.71 PK                | 88.30          | -29.59      | 1.00 H             | 0                    | 9.97             | 48.74                    |
| 10  | #10380.00   | 44.26 AV                | 68.30          | -24.04      | 1.00 H             | 0                    | -4.48            | 48.74                    |

| ANTENNA POLARITY & TEST DISTANCE: VERTICAL AT 3 M |             |                         |                |             |                    |                      |                  |                          |
|---|-------------|-------------------------|----------------|-------------|--------------------|----------------------|------------------|--------------------------|
| NO.   | FREQ. (MHz) | EMISSION LEVEL (dBuV/m) | LIMIT (dBuV/m) | MARGIN (dB) | ANTENNA HEIGHT (m) | TABLE ANGLE (Degree) | RAW VALUE (dBuV) | CORRECTION FACTOR (dB/m) |
| 1   | 1125.00     | 57.61 PK                | 74.00          | -16.39      | 1.00 V             | 360                  | 29.53            | 28.08                    |
| 2   | 1125.00     | 49.92 AV                | 54.00          | -4.08       | 1.00 V             | 360                  | 21.84            | 28.08                    |
| 3   | 5150.00     | 66.34 PK                | 74.00          | -7.66       | 1.02 V             | 21                   | 27.75            | 38.59                    |
| 4   | 5150.00     | 50.70 AV                | 54.00          | -3.30       | 1.02 V             | 21                   | 12.11            | 38.59                    |
| 5   | *5190.00    | 110.15 PK               |                |             | 1.02 V             | 21                   | 71.50            | 38.65                    |
| 6   | *5190.00    | 99.84 AV                |                |             | 1.02 V             | 21                   | 61.19            | 38.65                    |
| 7   | #6920.00    | 53.13 PK                | 88.30          | -35.17      | 1.46 V             | 223                  | 9.88             | 43.25                    |
| 8   | #6920.00    | 42.40 AV                | 68.30          | -25.90      | 1.46 V             | 223                  | -0.85            | 43.25                    |
| 9   | #10380.00   | 57.79 PK                | 88.30          | -30.51      | 1.00 V             | 0                    | 9.05             | 48.74                    |
| 10  | #10380.00   | 44.17 AV                | 68.30          | -24.13      | 1.00 V             | 0                    | -4.57            | 48.74                    |

- REMARKS:**
1. Emission level (dBuV/m) = Raw Value (dBuV) + Correction Factor (dB/m).
  2. Correction Factor (dB/m) = Antenna Factor (dB/m) + Cable Factor (dB).
  3. The other emission levels were very low against the limit.
  4. Margin value = Emission level – Limit value.
  5. “ \* “: Fundamental frequency.
  6. “#”: The radiated frequency is out the restricted band.



| EUT TEST CONDITION       |                           | MEASUREMENT DETAIL |                           |
|--------------------------|---------------------------|--------------------|---------------------------|
| CHANNEL                  | Channel 46                | FREQUENCY RANGE    | 1 ~ 40GHz                 |
| INPUT POWER (SYSTEM)     | 120Vac, 60 Hz             | DETECTOR FUNCTION  | Peak (PK)<br>Average (AV) |
| ENVIRONMENTAL CONDITIONS | 24deg. C, 68%RH<br>999hPa | TESTED BY          | Mitch Tsui                |

| ANTENNA POLARITY & TEST DISTANCE: HORIZONTAL AT 3 M |             |                         |                |             |                    |                      |                  |                          |
|---|-------------|-------------------------|----------------|-------------|--------------------|----------------------|------------------|--------------------------|
| NO.   | FREQ. (MHz) | EMISSION LEVEL (dBuV/m) | LIMIT (dBuV/m) | MARGIN (dB) | ANTENNA HEIGHT (m) | TABLE ANGLE (Degree) | RAW VALUE (dBuV) | CORRECTION FACTOR (dB/m) |
| 1   | 1125.00     | 55.31 PK                | 74.00          | -18.69      | 1.21 H             | 355                  | 27.23            | 28.08                    |
| 2   | 1125.00     | 45.69 AV                | 54.00          | -8.31       | 1.21 H             | 355                  | 17.61            | 28.08                    |
| 3   | *5230.00    | 98.42 PK                |                |             | 1.03 H             | 87                   | 59.72            | 38.70                    |
| 4   | *5230.00    | 88.01 AV                |                |             | 1.03 H             | 87                   | 49.31            | 38.70                    |
| 5   | 5350.00     | 60.35 PK                | 74.00          | -13.65      | 1.03 H             | 87                   | 21.54            | 38.81                    |
| 6   | 5350.00     | 47.41 AV                | 54.00          | -6.59       | 1.03 H             | 87                   | 8.60             | 38.81                    |
| 7   | #6973.00    | 50.70 PK                | 88.30          | -37.60      | 1.13 H             | 300                  | 7.17             | 43.53                    |
| 8   | #6973.00    | 39.47 AV                | 68.30          | -28.83      | 1.13 H             | 300                  | -4.06            | 43.53                    |
| 9   | #10460.00   | 59.04 PK                | 88.30          | -29.26      | 1.04 H             | 0                    | 10.09            | 48.95                    |
| 10  | #10460.00   | 44.64 AV                | 68.30          | -23.66      | 1.04 H             | 0                    | -4.31            | 48.95                    |
| ANTENNA POLARITY & TEST DISTANCE: VERTICAL AT 3 M   |             |                         |                |             |                    |                      |                  |                          |
| NO.   | FREQ. (MHz) | EMISSION LEVEL (dBuV/m) | LIMIT (dBuV/m) | MARGIN (dB) | ANTENNA HEIGHT (m) | TABLE ANGLE (Degree) | RAW VALUE (dBuV) | CORRECTION FACTOR (dB/m) |
| 1   | 1125.00     | 58.31 PK                | 74.00          | -15.69      | 1.00 V             | 14                   | 30.23            | 28.08                    |
| 2   | 1125.00     | 50.12 AV                | 54.00          | -3.88       | 1.00 V             | 14                   | 22.04            | 28.08                    |
| 3   | *5230.00    | 110.33 PK               |                |             | 1.01 V             | 26                   | 71.63            | 38.70                    |
| 4   | *5230.00    | 100.04 AV               |                |             | 1.01 V             | 26                   | 61.34            | 38.70                    |
| 5   | 5350.00     | 61.22 PK                | 74.00          | -12.78      | 1.01 V             | 26                   | 22.41            | 38.81                    |
| 6   | 5350.00     | 48.39 AV                | 54.00          | -5.61       | 1.01 V             | 26                   | 9.58             | 38.81                    |
| 7   | #6973.00    | 53.77 PK                | 88.30          | -34.53      | 1.31 V             | 300                  | 10.24            | 43.53                    |
| 8   | #6973.00    | 42.69 AV                | 68.30          | -25.61      | 1.31 V             | 300                  | -0.84            | 43.53                    |
| 9   | #10460.00   | 57.96 PK                | 88.30          | -30.34      | 1.00 V             | 360                  | 9.01             | 48.95                    |
| 10  | #10460.00   | 44.45 AV                | 68.30          | -23.85      | 1.00 V             | 360                  | -4.50            | 48.95                    |

- REMARKS:**
1. Emission level (dBuV/m) = Raw Value (dBuV) + Correction Factor (dB/m).
  2. Correction Factor (dB/m) = Antenna Factor (dB/m) + Cable Factor (dB).
  3. The other emission levels were very low against the limit.
  4. Margin value = Emission level – Limit value.
  5. “ \* “: Fundamental frequency.
  6. “#”: The radiated frequency is out the restricted band.



**BELOW 1GHz WORST-CASE DATA : DRAFT 802.11n (20MHz) OFDM MODULATION**

| EUT TEST CONDITION       |                           | MEASUREMENT DETAIL |               |
|--------------------------|---------------------------|--------------------|---------------|
| CHANNEL                  | Channel 36                | FREQUENCY RANGE    | Below 1000MHz |
| INPUT POWER (SYSTEM)     | 120Vac, 60 Hz             | DETECTOR FUNCTION  | Quasi-Peak    |
| ENVIRONMENTAL CONDITIONS | 25deg. C, 65%RH<br>999hPa | TESTED BY          | Lori Chiu     |

| ANTENNA POLARITY & TEST DISTANCE: HORIZONTAL AT 3 M |             |                         |                |             |                    |                      |                  |                          |
|---|-------------|-------------------------|----------------|-------------|--------------------|----------------------|------------------|--------------------------|
| NO.   | FREQ. (MHz) | EMISSION LEVEL (dBuV/m) | LIMIT (dBuV/m) | MARGIN (dB) | ANTENNA HEIGHT (m) | TABLE ANGLE (Degree) | RAW VALUE (dBuV) | CORRECTION FACTOR (dB/m) |
| 1   | 249.60      | 44.12 QP                | 46.00          | -1.88       | 1.25 H             | 154                  | 31.36            | 12.76                    |
| 2   | 270.99      | 39.59 QP                | 46.00          | -6.41       | 1.50 H             | 310                  | 26.47            | 13.12                    |
| 3   | 300.16      | 42.60 QP                | 46.00          | -3.40       | 1.25 H             | 124                  | 29.00            | 13.60                    |
| 4   | 500.42      | 42.96 QP                | 46.00          | -3.04       | 1.50 H             | 130                  | 23.85            | 19.12                    |
| 5   | 568.47      | 42.84 QP                | 46.00          | -3.16       | 1.25 H             | 229                  | 22.08            | 20.76                    |
| 6   | 877.61      | 44.42 QP                | 46.00          | -1.58       | 1.50 H             | 259                  | 18.78            | 25.64                    |

| ANTENNA POLARITY & TEST DISTANCE: VERTICAL AT 3 M |               |                         |                |              |                    |                      |                  |                          |
|---|---------------|-------------------------|----------------|--------------|--------------------|----------------------|------------------|--------------------------|
| NO.   | FREQ. (MHz)   | EMISSION LEVEL (dBuV/m) | LIMIT (dBuV/m) | MARGIN (dB)  | ANTENNA HEIGHT (m) | TABLE ANGLE (Degree) | RAW VALUE (dBuV) | CORRECTION FACTOR (dB/m) |
| 1   | 55.18         | 36.04 QP                | 40.00          | -3.96        | 1.50 V             | 292                  | 22.49            | 13.55                    |
| 2   | 64.90         | 35.34 QP                | 40.00          | -4.66        | 1.25 V             | 154                  | 22.90            | 12.45                    |
| 3   | 191.28        | 37.04 QP                | 43.50          | -6.46        | 1.00 V             | 199                  | 25.74            | 11.29                    |
| 4   | <b>249.60</b> | <b>44.75 QP</b>         | <b>46.00</b>   | <b>-1.25</b> | <b>1.00 V</b>      | <b>250</b>           | <b>31.99</b>     | <b>12.76</b>             |
| 5   | 500.42        | 44.43 QP                | 46.00          | -1.57        | 1.00 V             | 160                  | 25.31            | 19.12                    |
| 6   | 568.47        | 41.07 QP                | 46.00          | -4.93        | 1.00 V             | 163                  | 20.31            | 20.76                    |
| 7   | 877.61        | 43.48 QP                | 46.00          | -2.52        | 1.00 V             | 265                  | 17.84            | 25.64                    |

- REMARKS:**
1. Emission level (dBuV/m) = Raw Value (dBuV) + Correction Factor (dB/m).
  2. Correction Factor (dB/m) = Antenna Factor (dB/m) + Cable Factor (dB).
  3. The other emission levels were very low against the limit.
  4. Margin value = Emission level – Limit value.



## 4.2 CONDUCTED EMISSION MEASUREMENT

### 4.2.1 LIMITS OF CONDUCTED EMISSION MEASUREMENT

| FREQUENCY OF EMISSION (MHz) | CONDUCTED LIMIT (dB $\mu$ V) |          |
|-----------------------------|------------------------------|----------|
|                             | Quasi-peak                   | Average  |
| 0.15 ~ 0.5                  | 66 to 56                     | 56 to 46 |
| 0.5 ~ 5                     | 56                           | 46       |
| 5 ~ 30                      | 60                           | 50       |

- NOTE:**
1. The lower limit shall apply at the transition frequencies.
  2. The limit decreases in line with the logarithm of the frequency in the range of 0.15 to 0.50MHz.
  3. All emanations from a class A/B digital device or system, including any network of conductors and apparatus connected thereto, shall not exceed the level of field strengths specified above.

### 4.2.2 TEST INSTRUMENTS

| DESCRIPTION & MANUFACTURER       | MODEL NO.   | SERIAL NO.     | CALIBRATED UNTIL |
|----------------------------------|-------------|----------------|------------------|
| Test Receiver<br>ROHDE & SCHWARZ | ESCS30      | 100288         | Sep. 21, 2008    |
| RF signal cable<br>Woken         | 5D-FB       | Cable-HYCO3-01 | Jan. 06, 2009    |
| LISN<br>ROHDE & SCHWARZ          | ESH2-Z5     | 100100         | Jan. 09, 2009    |
| LISN<br>SCHWARZBECK              | ESH3-Z5     | 100311         | Jan. 21, 2009    |
| Software<br>ADT                  | ADT_Cond_V3 | NA             | NA               |

- NOTE:**
1. The calibration interval of the above test instruments is 12 months and the calibrations are traceable to NML/ROC and NIST/USA.
  2. The test was performed in HwaYa Shielded Room 2.
  3. The VCCI Site Registration No. is C-2047.

#### 4.2.3 TEST PROCEDURES

- a. The EUT was placed 0.4 meters from the conducting wall of the shielded room with EUT being connected to the power mains through a line impedance stabilization network (LISN). Other support units were connected to the power mains through another LISN. The two LISNs provide 50 ohm/ 50uH of coupling impedance for the measuring instrument.
- b. Both lines of the power mains connected to the EUT were checked for maximum conducted interference.
- c. The frequency range from 150kHz to 30MHz was searched. Emission levels under (Limit - 20dB) was not recorded.

#### 4.2.4 DEVIATION FROM TEST STANDARD

No deviation

#### 4.2.5 TEST SETUP

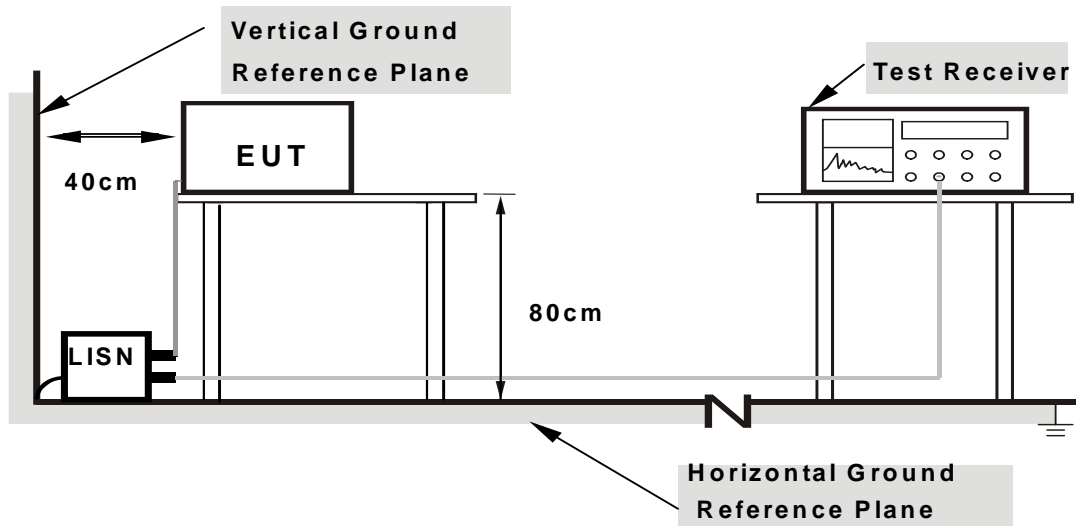

- Note:**
1. Support units were connected to second LISN.
  2. Both of LISNs (AMN) are 80 cm from EUT and at least 80 from other units and other metal planes

For the actual test configuration, please refer to the attached file (Test Setup Photo).

#### 4.2.6 EUT OPERATING CONDITIONS

Same as 4.1.6.

## 4.2.7 TEST RESULTS

### CONDUCTED WORST-CASE DATA : DRAFT 802.11n (20MHz) OFDM MODULATION

| EUT TEST CONDITION       |                         | MEASUREMENT DETAIL   |              |
|--------------------------|-------------------------|----------------------|--------------|
| CHANNEL                  | Channel 36              | PHASE                | Line 1       |
| MODULATION TYPE          | BPSK                    | INPUT POWER (SYSTEM) | 120Vac, 60Hz |
| TRANSFER RATE            | 7.2Mbps                 | 6dB BANDWIDTH        | 9kHz         |
| ENVIRONMENTAL CONDITIONS | 25deg. C, 65%RH, 982hPa | TESTED BY            | Brad Wu      |

| No | Freq. [MHz] | Corr. Factor (dB) | Reading Value [dB (uV)] |     | Emission Level [dB (uV)] |     | Limit [dB (uV)] |       | Margin (dB) |     |
|----|-------------|-------------------|-------------------------|-----|--------------------------|-----|-----------------|-------|-------------|-----|
|    |             |                   | Q.P.                    | AV. | Q.P.                     | AV. | Q.P.            | AV.   | Q.P.        | AV. |
|    |             |                   |                         |     |                          |     |                 |       |             |     |
| 1  | 0.150       | 0.10              | 48.97                   | -   | 49.07                    | -   | 66.00           | 56.00 | -16.93      | -   |
| 2  | 0.185       | 0.10              | 49.91                   | -   | 50.01                    | -   | 64.25           | 54.25 | -14.24      | -   |
| 3  | 0.240       | 0.10              | 44.63                   | -   | 44.73                    | -   | 62.10           | 52.10 | -17.37      | -   |
| 4  | 4.234       | 0.28              | 20.58                   | -   | 20.86                    | -   | 56.00           | 46.00 | -35.14      | -   |
| 5  | 7.609       | 0.31              | 22.43                   | -   | 22.74                    | -   | 60.00           | 50.00 | -37.26      | -   |
| 6  | 16.215      | 0.50              | 22.67                   | -   | 23.17                    | -   | 60.00           | 50.00 | -36.83      | -   |

- REMARKS:**
1. Q.P. and AV. are abbreviations of quasi-peak and average individually.
  2. "-": The Quasi-peak reading value also meets average limit and measurement with the average detector is unnecessary.
  3. The emission levels of other frequencies were very low against the limit.
  4. Margin value = Emission level - Limit value
  5. Correction factor = Insertion loss + Cable loss
  6. Emission Level = Correction Factor + Reading Value.

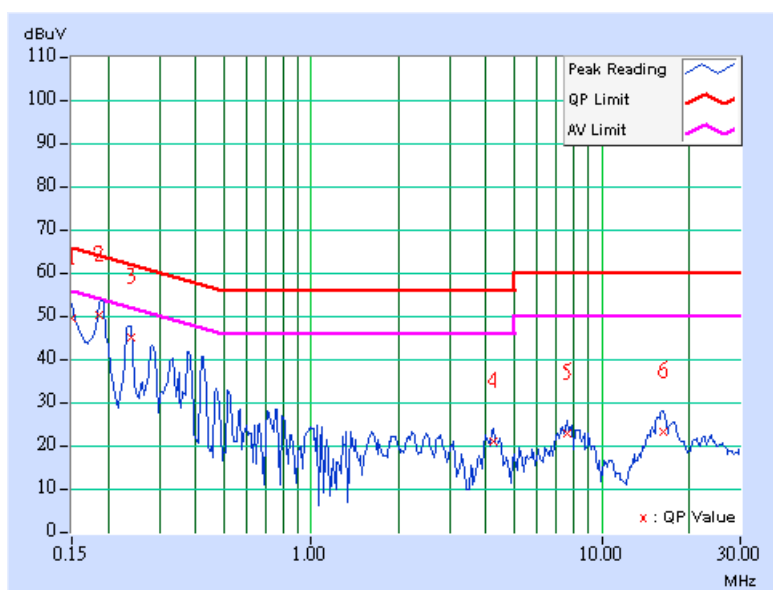

| EUT TEST CONDITION       |                         | MEASUREMENT DETAIL   |              |
|--------------------------|-------------------------|----------------------|--------------|
| CHANNEL                  | Channel 36              | PHASE                | Line 2       |
| MODULATION TYPE          | BPSK                    | INPUT POWER (SYSTEM) | 120Vac, 60Hz |
| TRANSFER RATE            | 7.2Mbps                 | 6dB BANDWIDTH        | 9kHz         |
| ENVIRONMENTAL CONDITIONS | 25deg. C, 65%RH, 982hPa | TESTED BY            | Brad Wu      |

| No | Freq. [MHz] | Corr. Factor (dB) | Reading Value [dB (uV)] |     | Emission Level [dB (uV)] |     | Limit [dB (uV)] |       | Margin (dB) |     |
|----|-------------|-------------------|-------------------------|-----|--------------------------|-----|-----------------|-------|-------------|-----|
|    |             |                   | Q.P.                    | AV. | Q.P.                     | AV. | Q.P.            | AV.   | Q.P.        | AV. |
| 1  | 0.189       | 0.10              | 51.93                   | -   | 52.03                    | -   | 64.08           | 54.08 | -12.05      | -   |
| 2  | 0.236       | 0.10              | 45.66                   | -   | 45.76                    | -   | 62.24           | 52.24 | -16.48      | -   |
| 3  | 0.423       | 0.10              | 34.07                   | -   | 34.17                    | -   | 57.38           | 47.38 | -23.21      | -   |
| 4  | 3.773       | 0.27              | 22.27                   | -   | 22.54                    | -   | 56.00           | 46.00 | -33.46      | -   |
| 5  | 7.488       | 0.37              | 23.02                   | -   | 23.39                    | -   | 60.00           | 50.00 | -36.61      | -   |
| 6  | 15.930      | 0.50              | 24.26                   | -   | 24.76                    | -   | 60.00           | 50.00 | -35.24      | -   |

- REMARKS:**
1. Q.P. and AV. are abbreviations of quasi-peak and average individually.
  2. "-": The Quasi-peak reading value also meets average limit and measurement with the average detector is unnecessary.
  3. The emission levels of other frequencies were very low against the limit.
  4. Margin value = Emission level - Limit value
  5. Correction factor = Insertion loss + Cable loss
  6. Emission Level = Correction Factor + Reading Value.

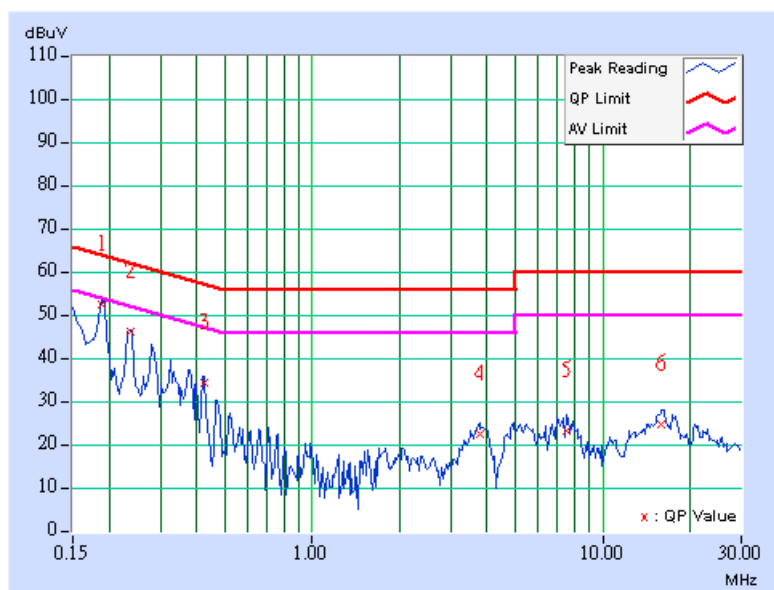



### 4.3 PEAK TRANSMIT POWER MEASUREMENT

#### 4.3.1 LIMITS OF PEAK TRANSMIT POWER MEASUREMENT

| FREQUENCY BAND | LIMIT                                       |
|----------------|---|
| 5.15 ~ 5.25GHz | The lesser of 50mW (17dBm) or 4dBm + 10logB |

**NOTE:** Where B is the 26dB emission bandwidth in MHz.

#### 4.3.2 TEST INSTRUMENTS

| DESCRIPTION & MANUFACTURER | MODEL NO. | SERIAL NO. | CALIBRATED UNTIL |
|----------------------------|-----------|------------|------------------|
| R&S SPECTRUM ANALYZER      | FSP40     | 100040     | Jun. 28, 2008    |

**NOTE:** The calibration interval of the above test instruments is 12 months and the calibrations are traceable to NML/ROC and NIST/USA.

#### 4.3.3 TEST PROCEDURE

- a. The transmitter output was connected to the spectrum analyzer.
- b. Set span to encompass the entire emission bandwidth of the signal.
- c. Set RBW to 1MHz, VBW to 3MHz.
- d. Using the spectrum analyzer's channel power measurement function to measure the output power.

**NOTE:** The test is performed in accordance with FCC Public Notice: APPENDIX A Guidelines for Assessing Unlicensed National Information Infrastructure (U-NII) Devices – Part 15, Subpart E, August 2002.

The transmitter output operates continuously therefore Method # 1 is used.

#### 4.3.4 DEVIATION FROM TEST STANDARD

No deviation

#### 4.3.5 TEST SETUP

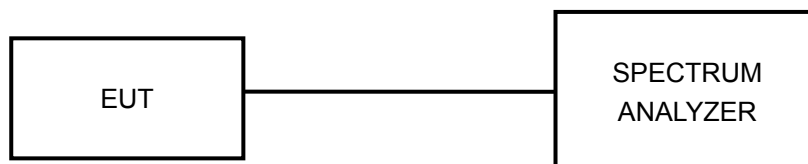

#### 4.3.6 EUT OPERATING CONDITIONS

The software provided by client to enable the EUT under transmission condition continuously at specific channel frequencies individually.

### 4.3.7 TEST RESULTS

#### PEAK POWER OUTPUT: 802.11a OFDM MODULATION

|                             |              |                                 |                          |
|-----------------------------|--------------|---------------------------------|--------------------------|
| <b>MODULATION TYPE</b>      | BPSK         | <b>TRANSFER RATE</b>            | 6.0Mbps                  |
| <b>INPUT POWER (SYSTEM)</b> | 120Vac, 60Hz | <b>ENVIRONMENTAL CONDITIONS</b> | 26 deg.C, 67 %RH, 991hPa |
| <b>TESTED BY</b>            | Dean Wang    |                                 |                          |

| CHANNEL | CHANNEL FREQUENCY (MHz) | PEAK POWER OUTPUT (mW) | PEAK POWER OUTPUT (dBm) | PEAK POWER LIMIT (dBm) | PASS / FAIL |
|---------|-------------------------|------------------------|-------------------------|------------------------|-------------|
| 36      | 5180                    | 32.063                 | 15.06                   | 17.00                  | PASS        |
| 40      | 5200                    | 31.915                 | 15.04                   | 17.00                  | PASS        |
| 48      | 5240                    | 32.434                 | 15.11                   | 17.00                  | PASS        |

#### CH 36

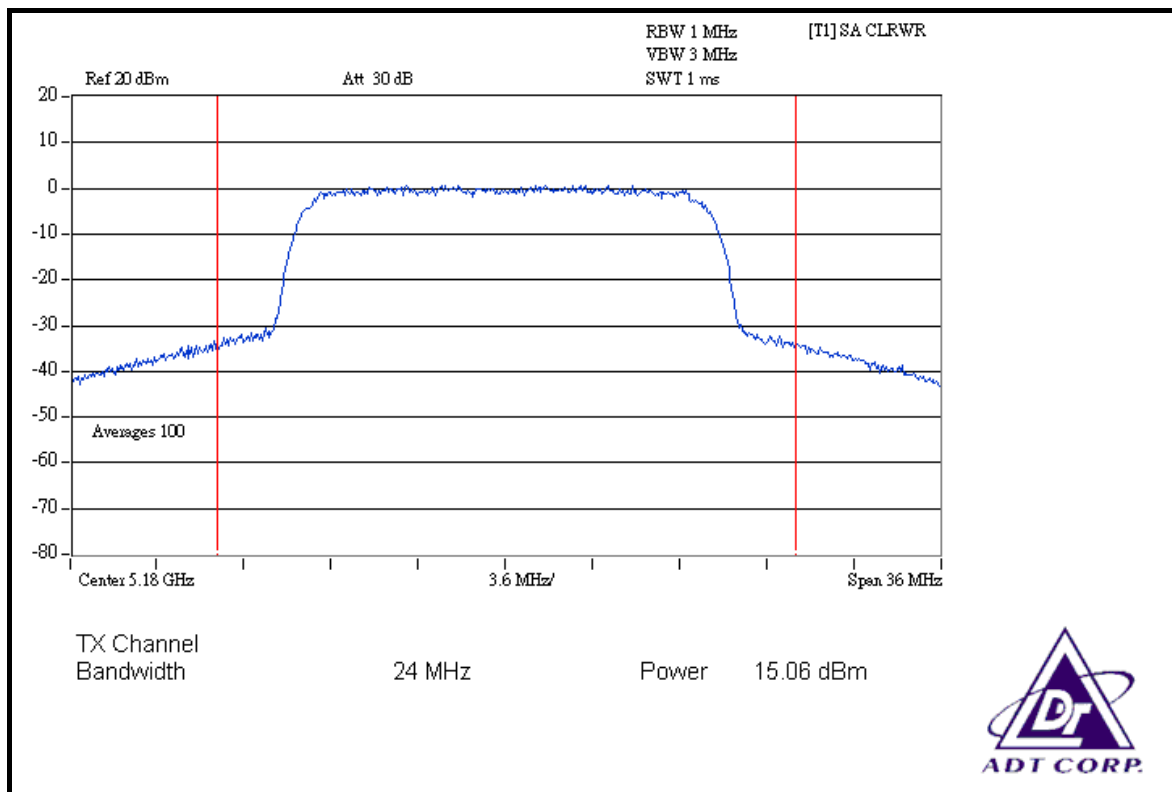



### CH 40

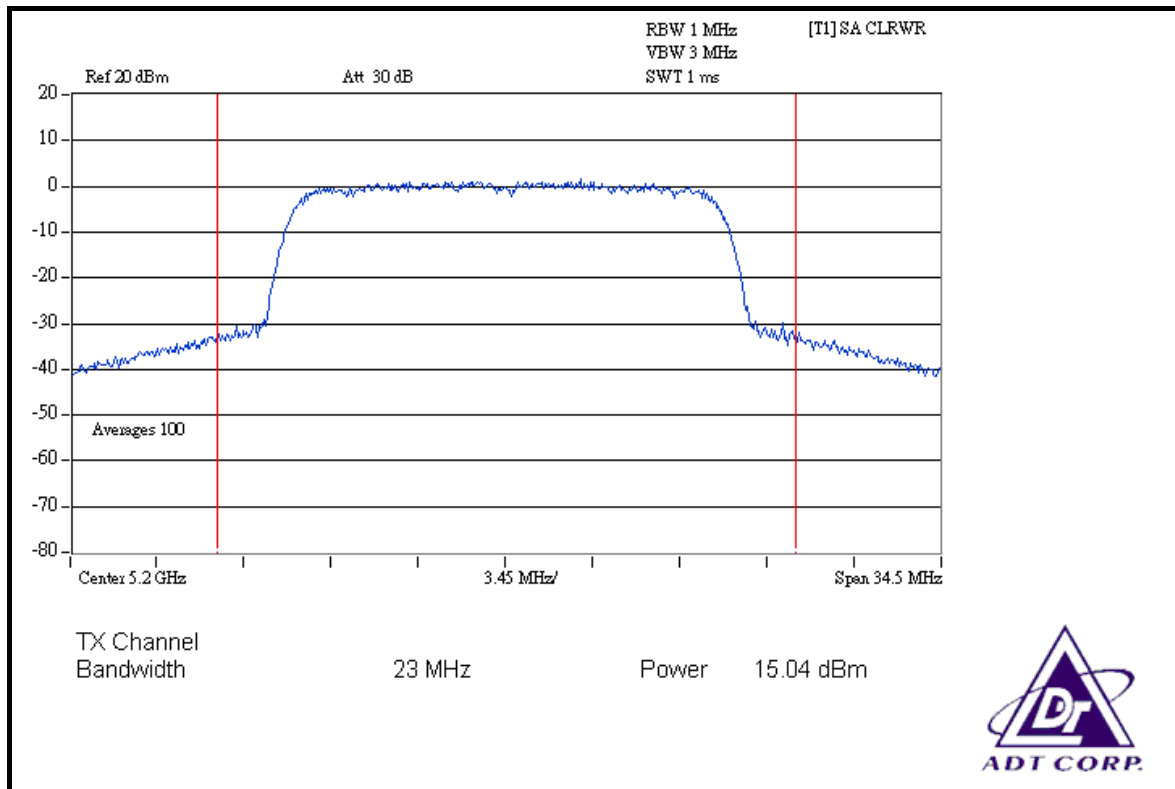

### CH 48

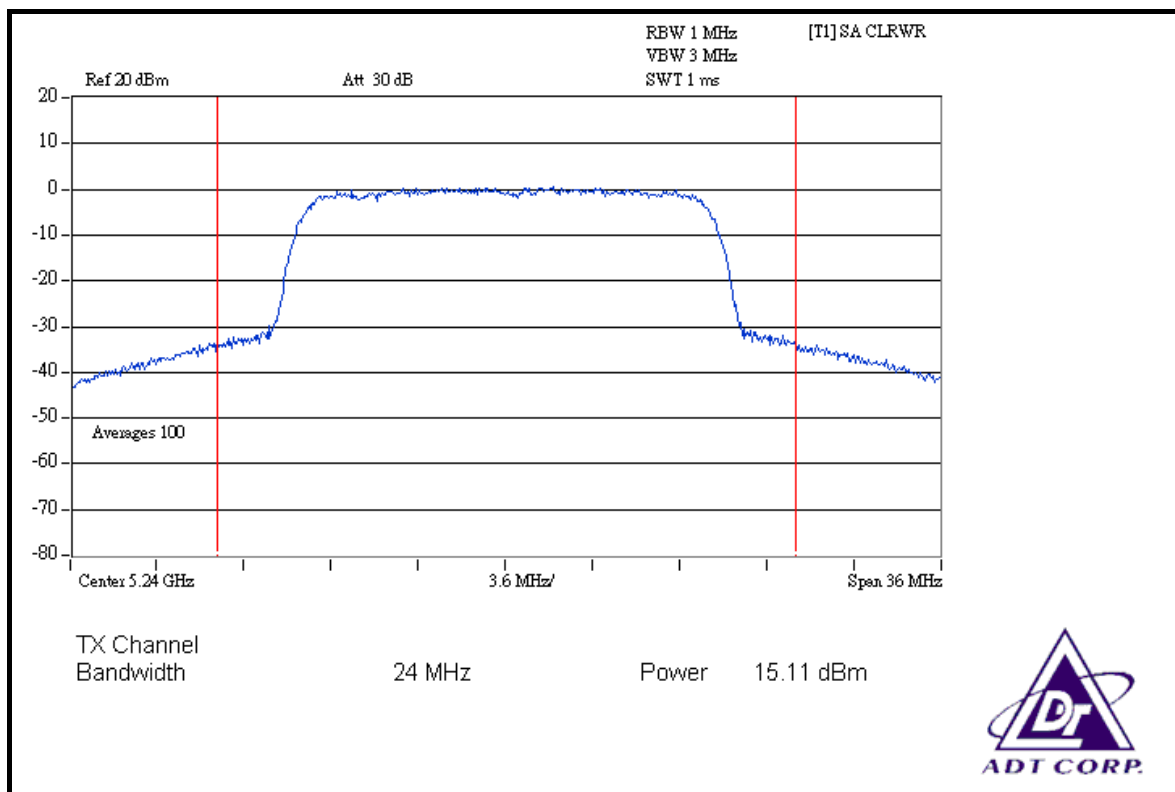



**DRAFT 802.11n (20MHz) OFDM MODULATION**

|                             |              |                                 |                          |
|-----------------------------|--------------|---------------------------------|--------------------------|
| <b>MODULATION TYPE</b>      | BPSK         | <b>TRANSFER RATE</b>            | 7.2Mbps                  |
| <b>INPUT POWER (SYSTEM)</b> | 120Vac, 60Hz | <b>ENVIRONMENTAL CONDITIONS</b> | 26 deg.C, 67 %RH, 991hPa |
| <b>TESTED BY</b>            | Dean Wang    |                                 |                          |

| CHAN. | CHAN. FREQ. (MHz) | PEAK POWER OUTPUT (dBm) |         |         | TOTAL PEAK POWER (mW) | TOTAL PEAK POWER (dBm) | PEAK POWER LIMIT (dBm) | PASS / FAIL |
|-------|-------------------|-------------------------|---------|---------|-----------------------|------------------------|------------------------|-------------|
|       |                   | CHAIN 0                 | CHAIN 1 | CHAIN 1 |                       |                        |                        |             |
| 36    | 5180              | 10.53                   | 11.11   | 11.14   | 37.212                | 15.71                  | 30                     | PASS        |
| 40    | 5200              | 10.02                   | 11.07   | 11.10   | 35.722                | 15.53                  | 30                     | PASS        |
| 48    | 5240              | 10.57                   | 11.52   | 11.04   | 38.299                | 15.83                  | 30                     | PASS        |

**FOR CHAIN 0: CH 36**

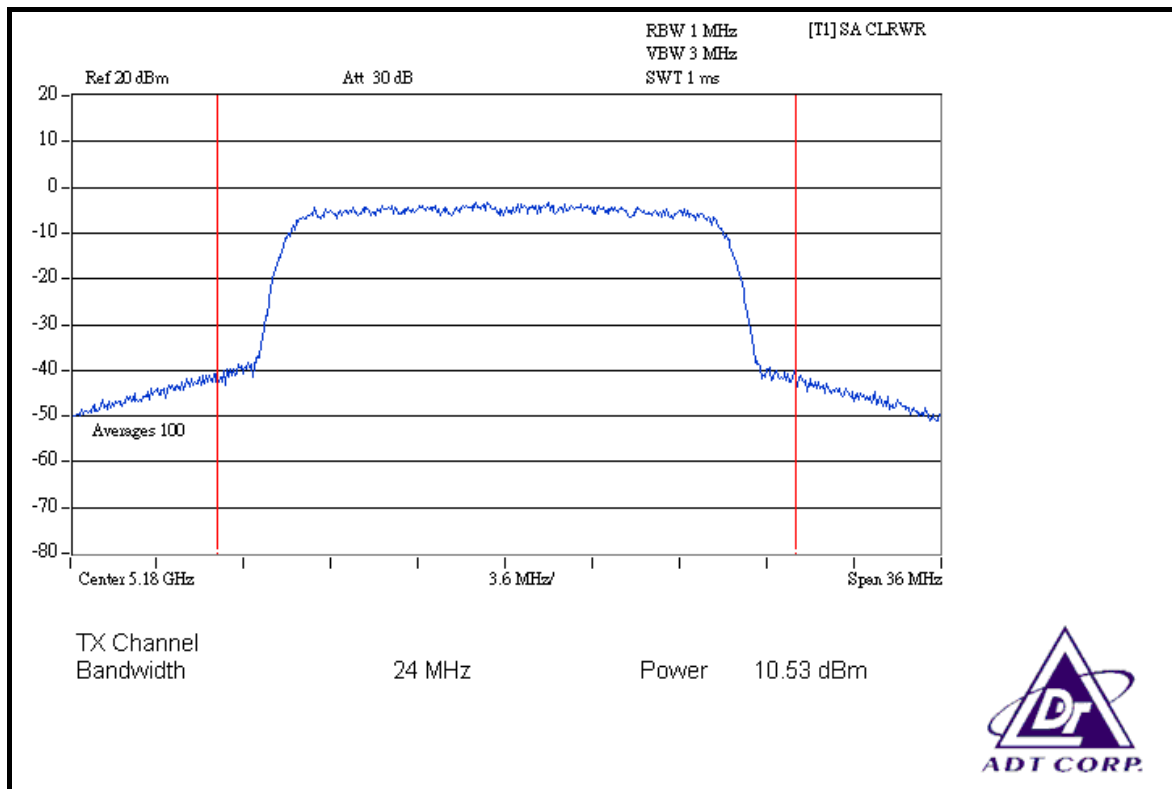

### CH 40

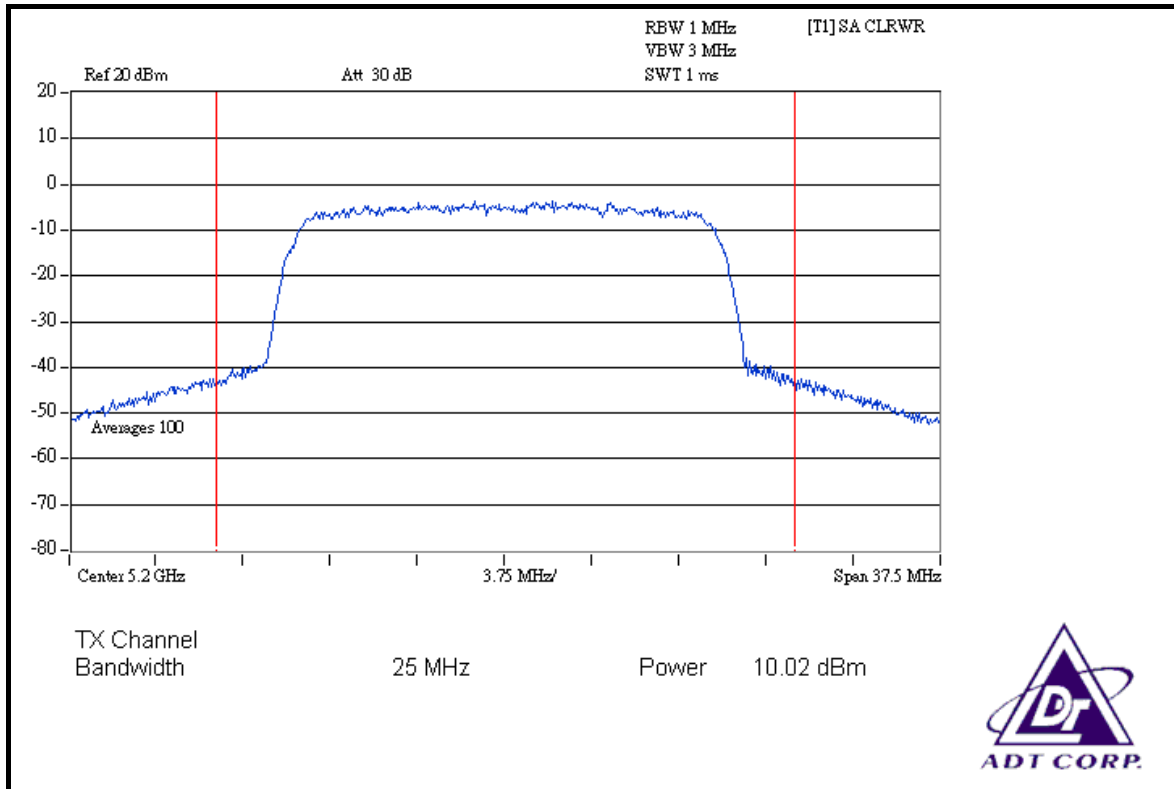

### CH 48

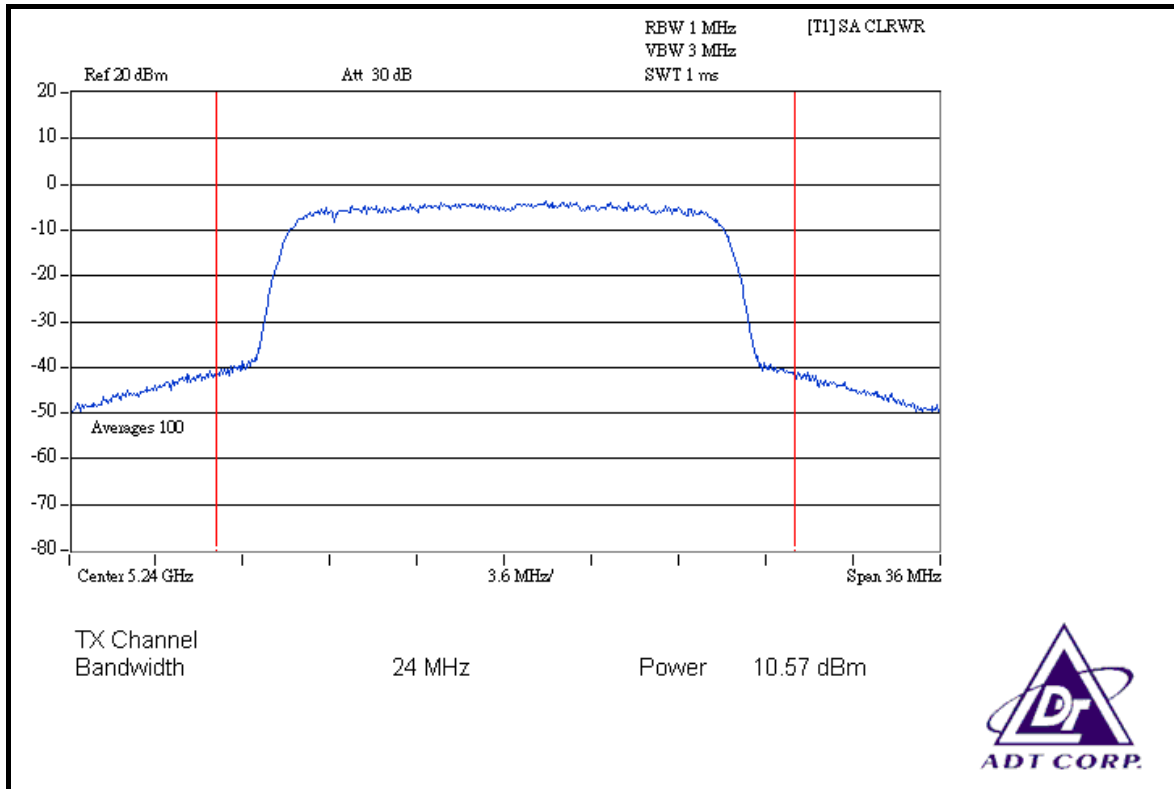



### FOR CHAIN 1: CH 36

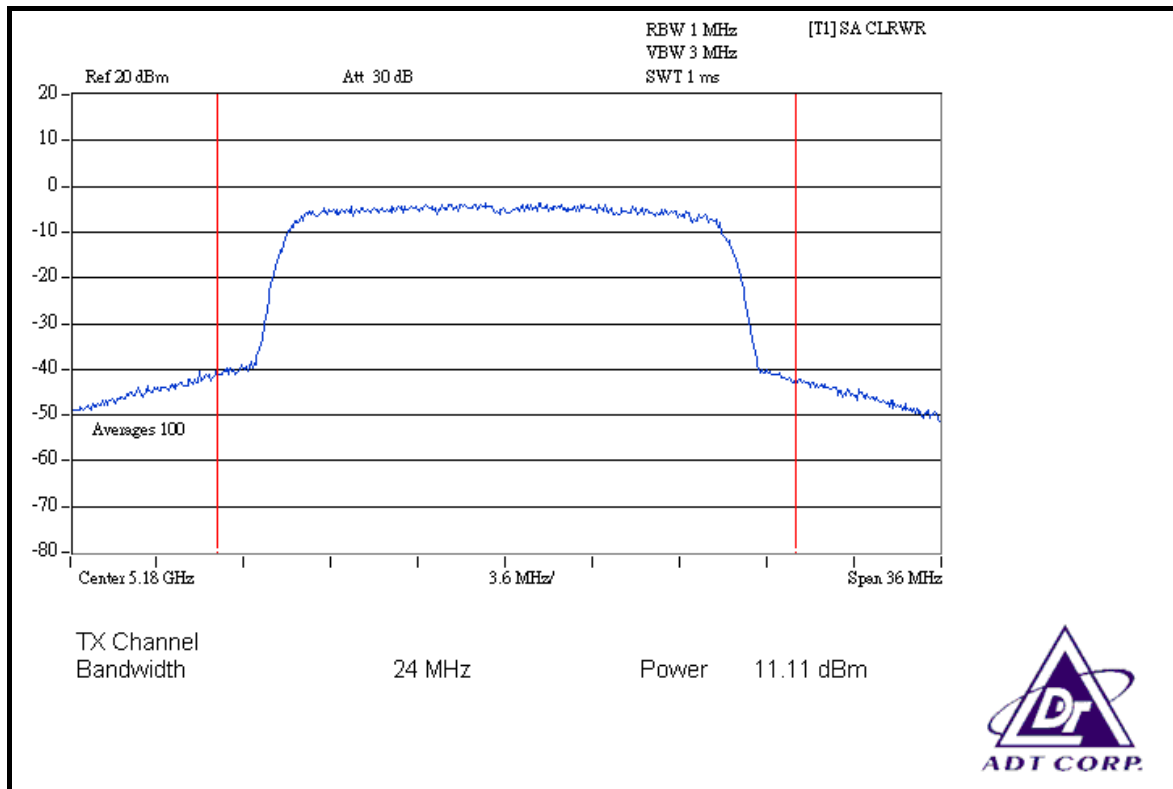

### CH 40

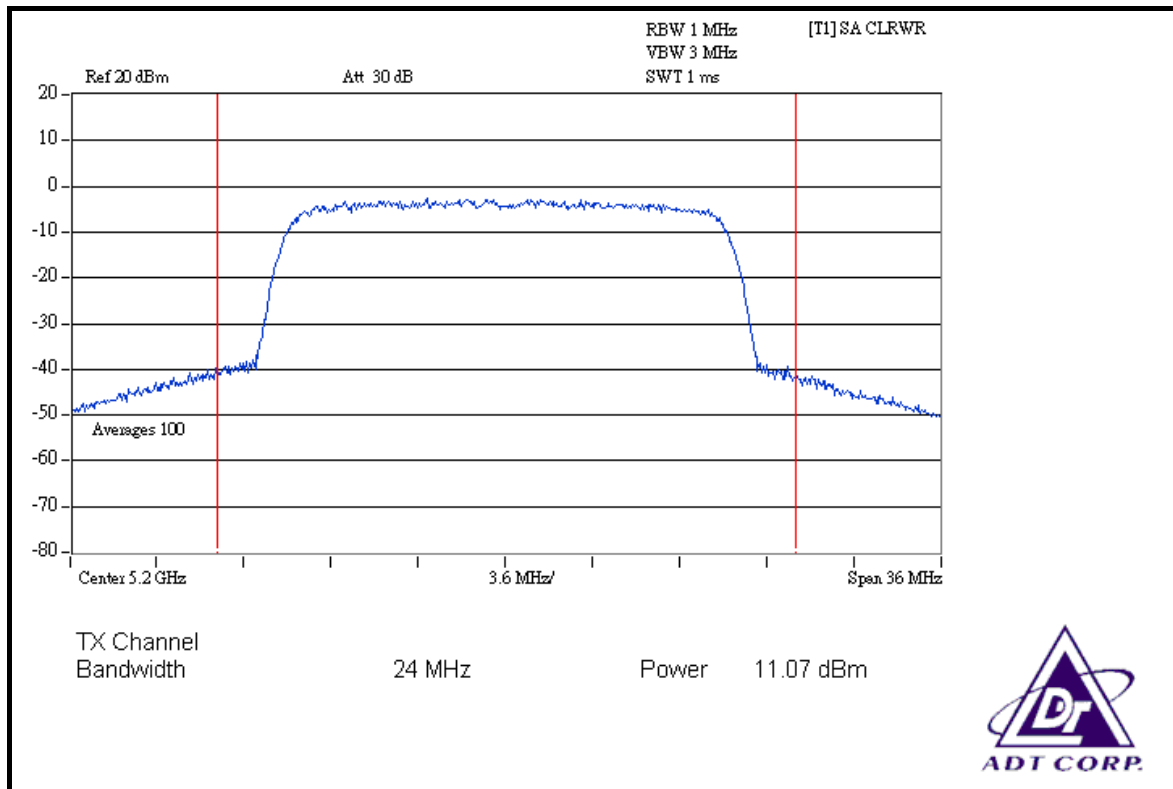

### CH 48

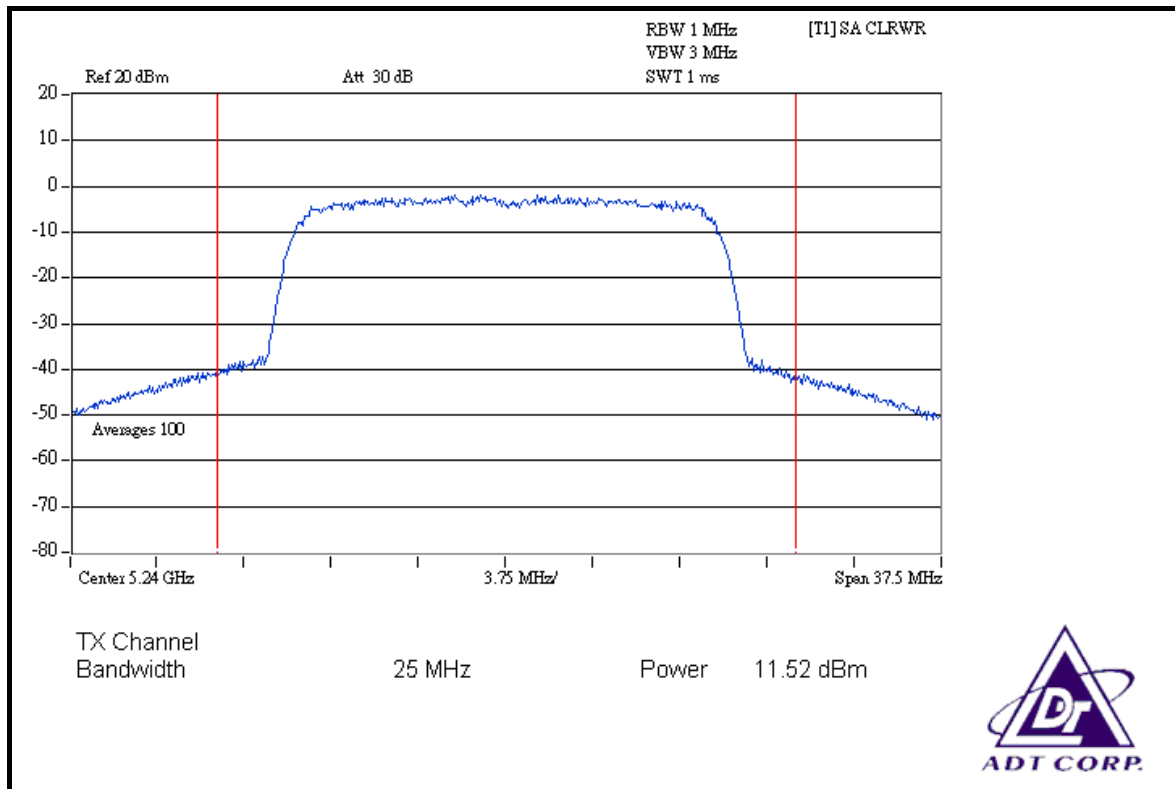

### FOR CHAIN 2: CH 36

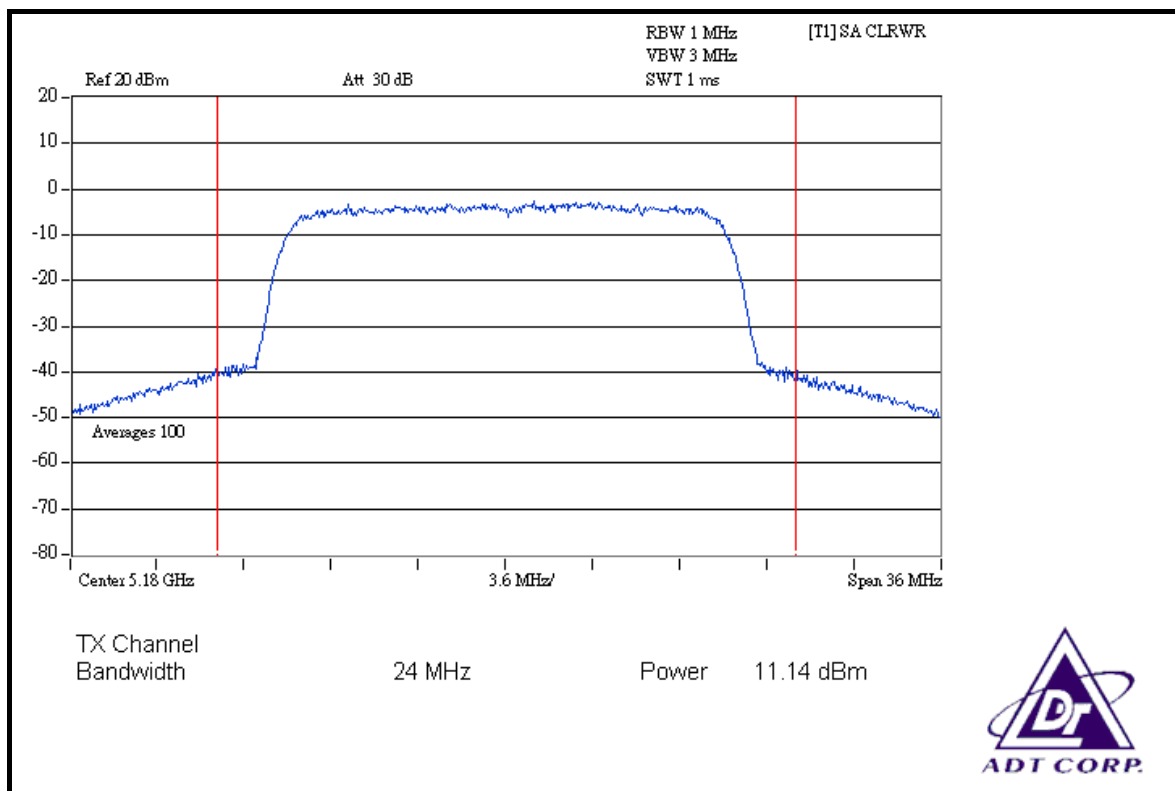

### CH 40

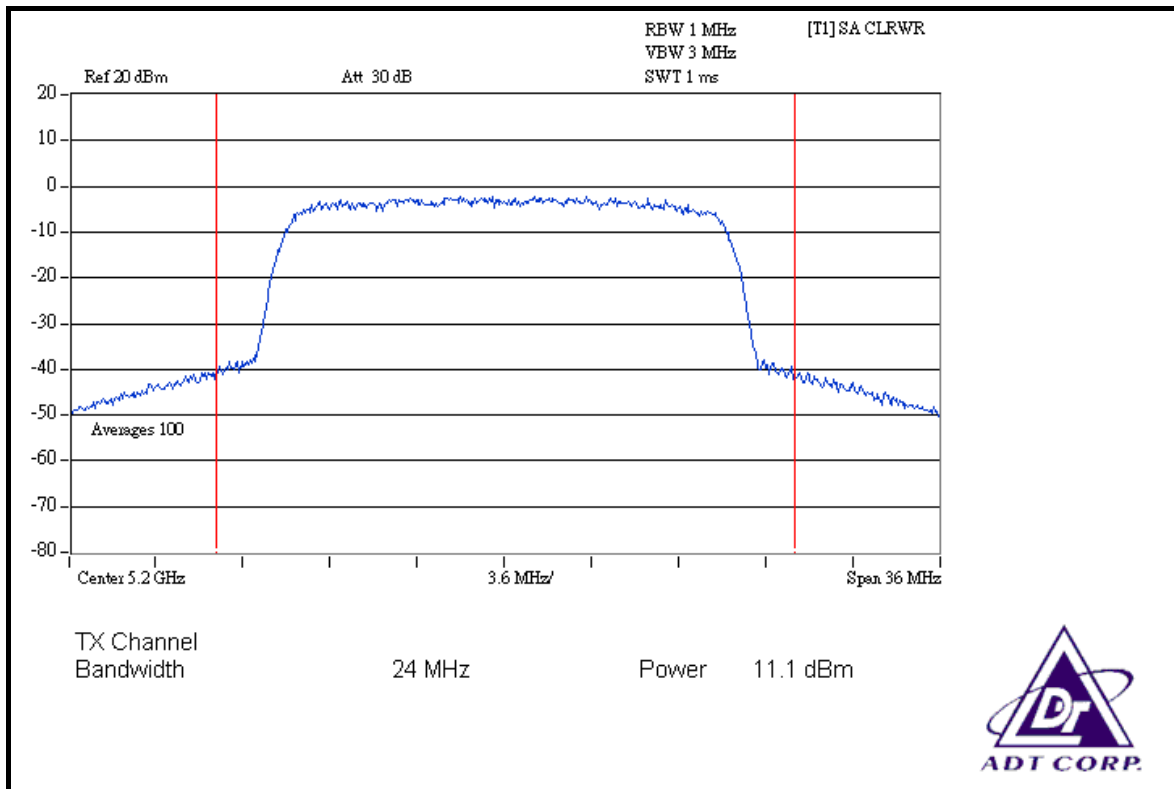

### CH 48

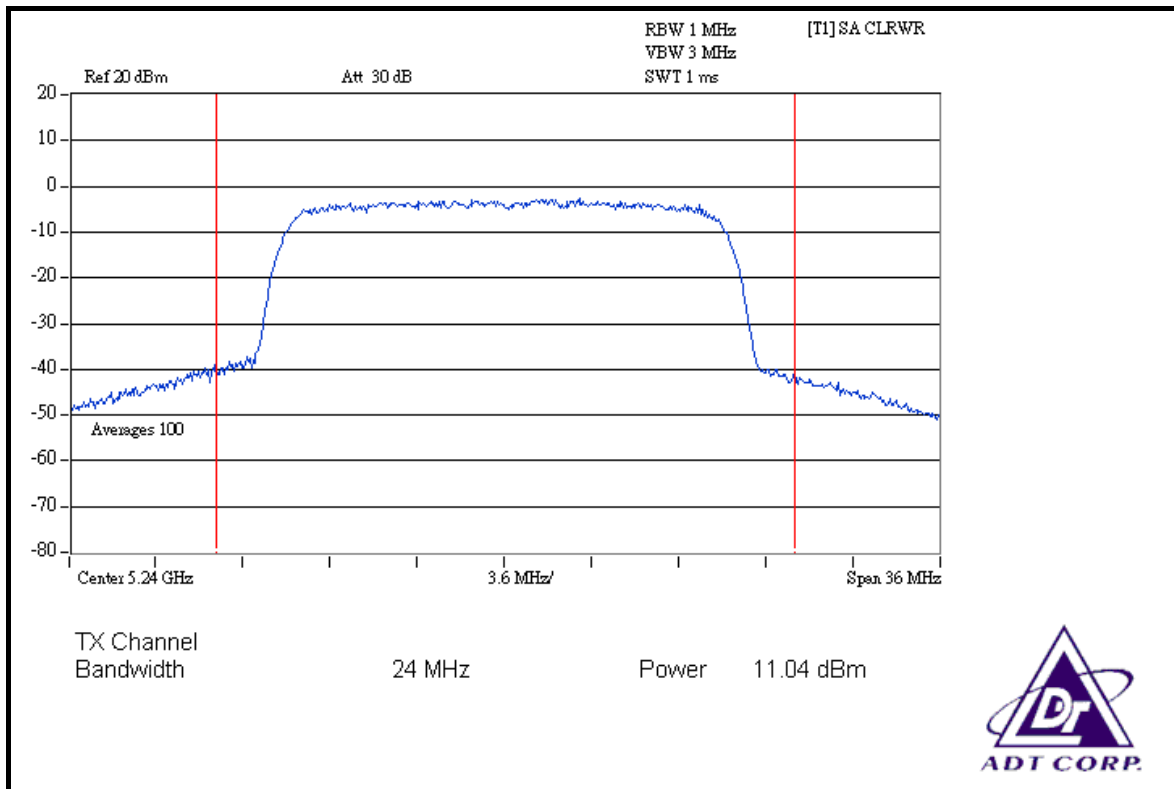



**DRAFT 802.11n (40MHz) OFDM MODULATION**

|                             |              |                                 |                          |
|-----------------------------|--------------|---------------------------------|--------------------------|
| <b>MODULATION TYPE</b>      | BPSK         | <b>TRANSFER RATE</b>            | 15Mbps                   |
| <b>INPUT POWER (SYSTEM)</b> | 120Vac, 60Hz | <b>ENVIRONMENTAL CONDITIONS</b> | 26 deg.C, 67 %RH, 991hPa |
| <b>TESTED BY</b>            | Dean Wang    |                                 |                          |

| CHAN. | CHAN. FREQ. (MHz) | PEAK POWER OUTPUT (dBm) |         |         | TOTAL PEAK POWER (mW) | TOTAL PEAK POWER (dBm) | PEAK POWER LIMIT (dBm) | PASS / FAIL |
|-------|-------------------|-------------------------|---------|---------|-----------------------|------------------------|------------------------|-------------|
|       |                   | CHAIN 0                 | CHAIN 1 | CHAIN 2 |                       |                        |                        |             |
| 38    | 5190              | 10.06                   | 11.58   | 11.13   | 37.499                | 15.74                  | 30                     | PASS        |
| 46    | 5230              | 10.54                   | 11.56   | 11.50   | 39.771                | 16.00                  | 30                     | PASS        |



### FOR CHAIN 0: CH 38

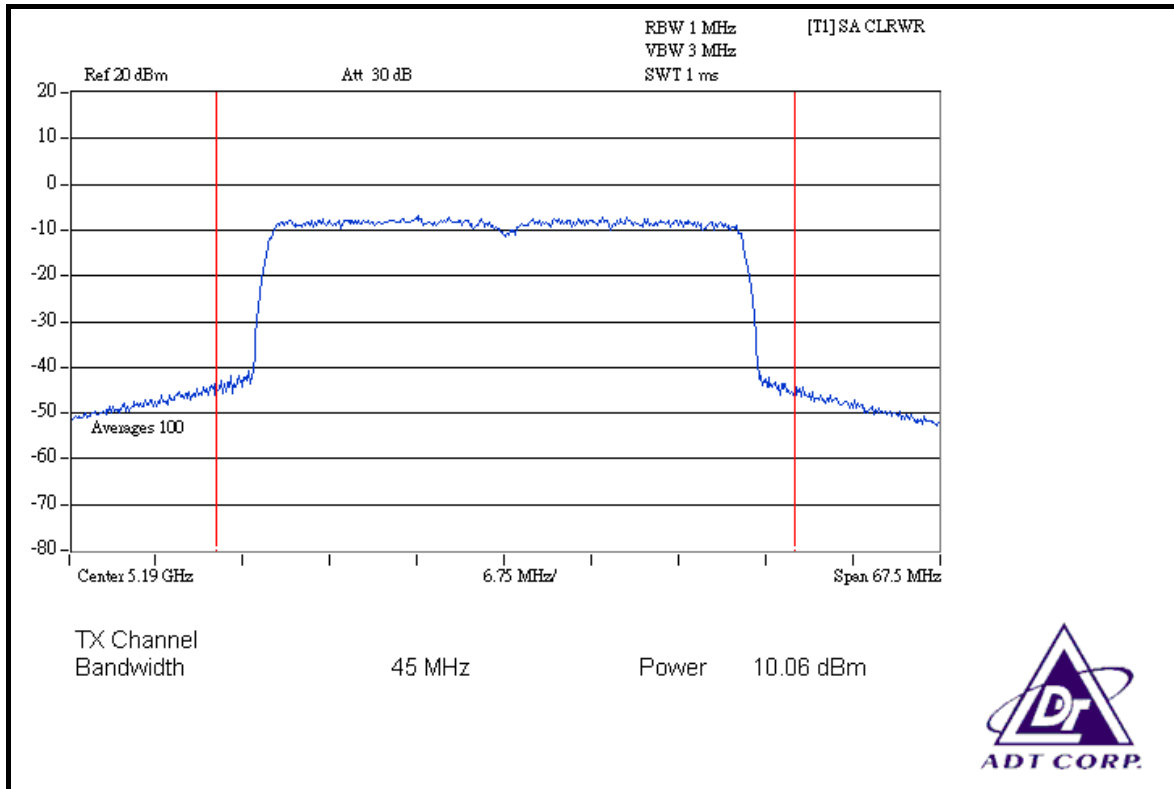

### CH 46

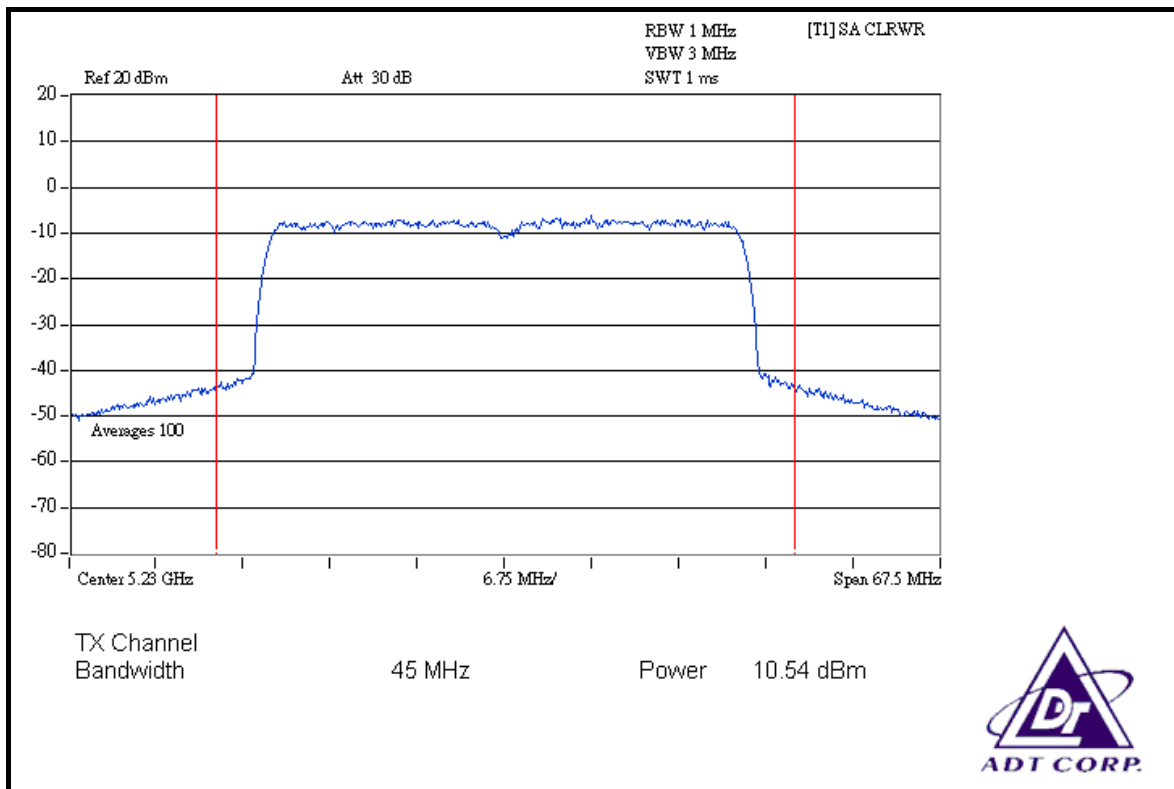





### FOR CHAIN 1: CH 38

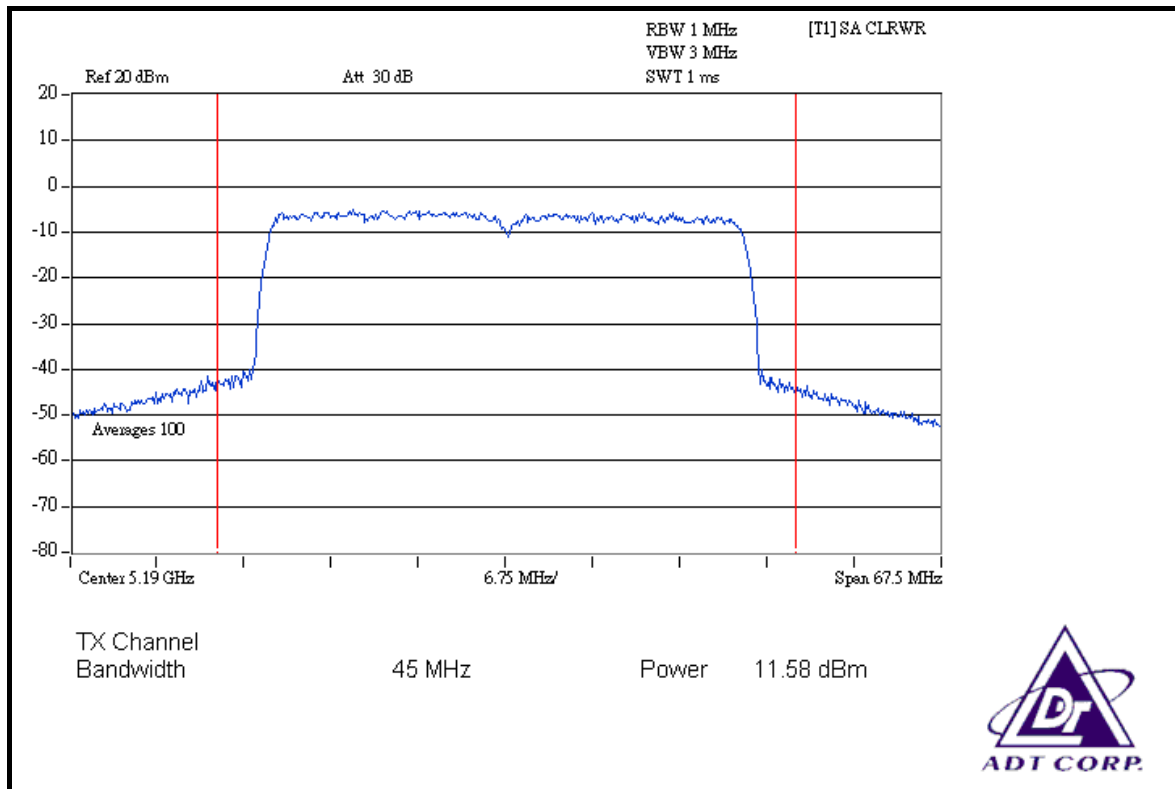

### CH 46

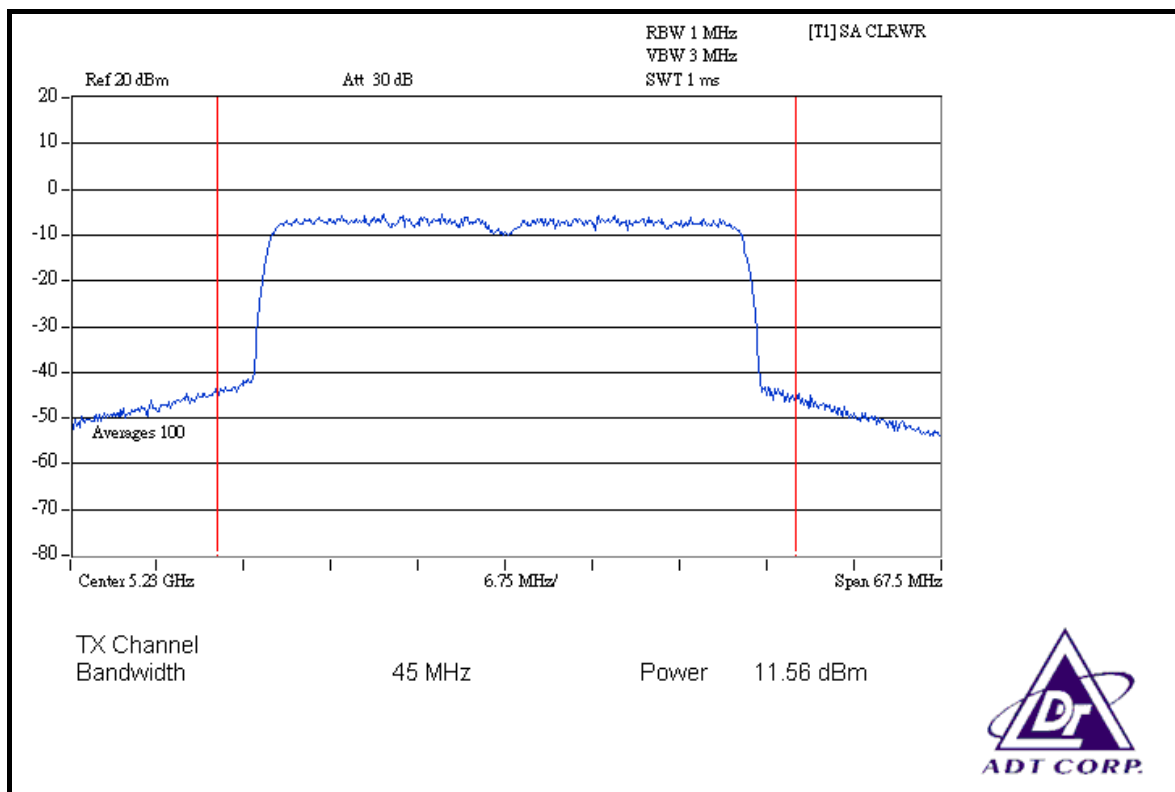



### FOR CHAIN 2: CH 38

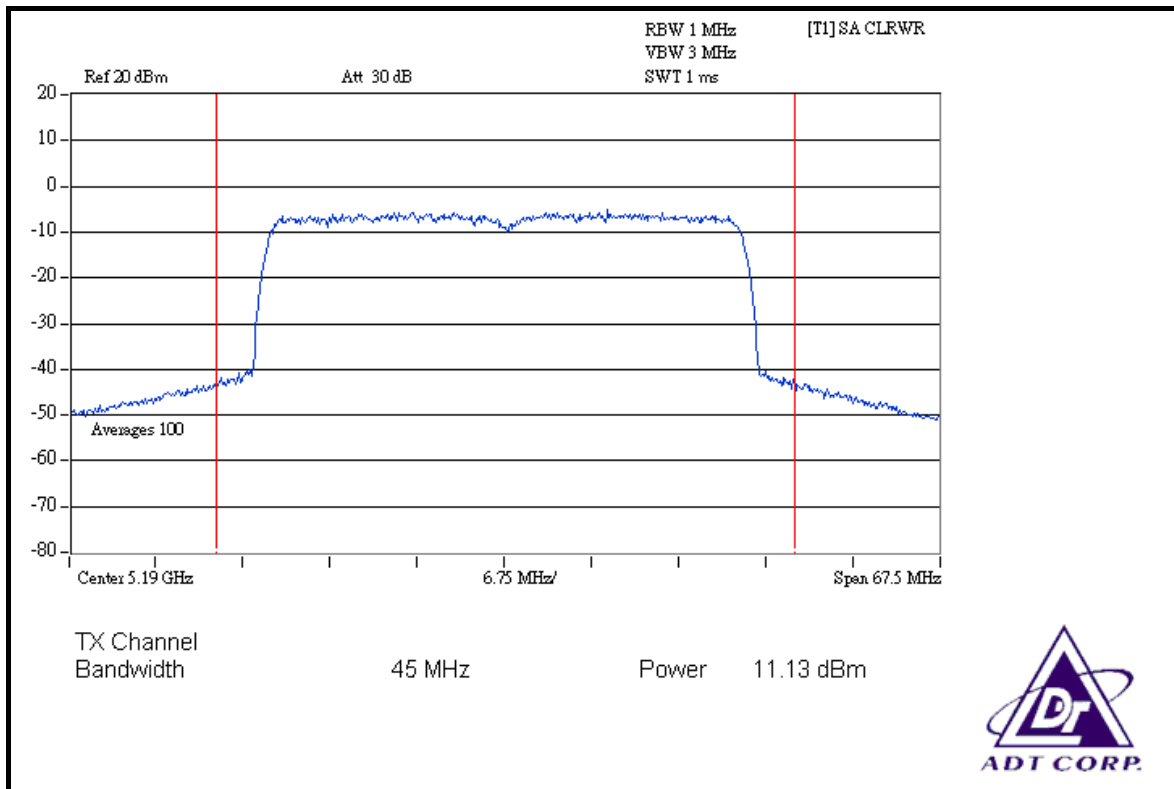

### CH 46

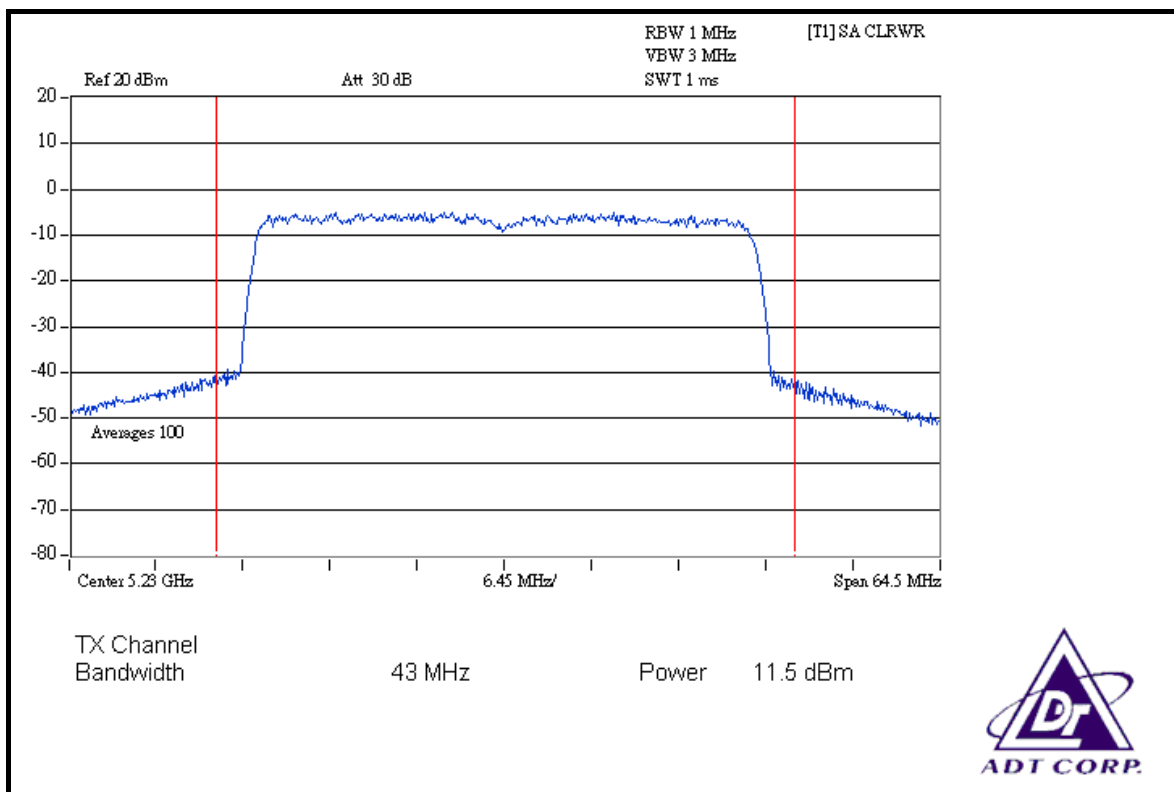



**26dB OCCUPIED BANDWIDTH: 802.11a OFDM MODULATION**

|                             |              |                                 |                          |
|-----------------------------|--------------|---------------------------------|--------------------------|
| <b>MODULATION TYPE</b>      | BPSK         | <b>TRANSFER RATE</b>            | 6.0Mbps                  |
| <b>INPUT POWER (SYSTEM)</b> | 120Vac, 60Hz | <b>ENVIRONMENTAL CONDITIONS</b> | 26 deg.C, 67 %RH, 991hPa |
| <b>TESTED BY</b>            | Dean Wang    |                                 |                          |

| CHANNEL | CHANNEL FREQUENCY (MHz) | 26dBc OCCUPIED BANDWIDTH (MHz) | PASS / FAIL |
|---------|-------------------------|--------------------------------|-------------|
| 36      | 5180                    | 23.03                          | PASS        |
| 40      | 5200                    | 22.70                          | PASS        |
| 48      | 5240                    | 23.28                          | PASS        |

**CH 36**

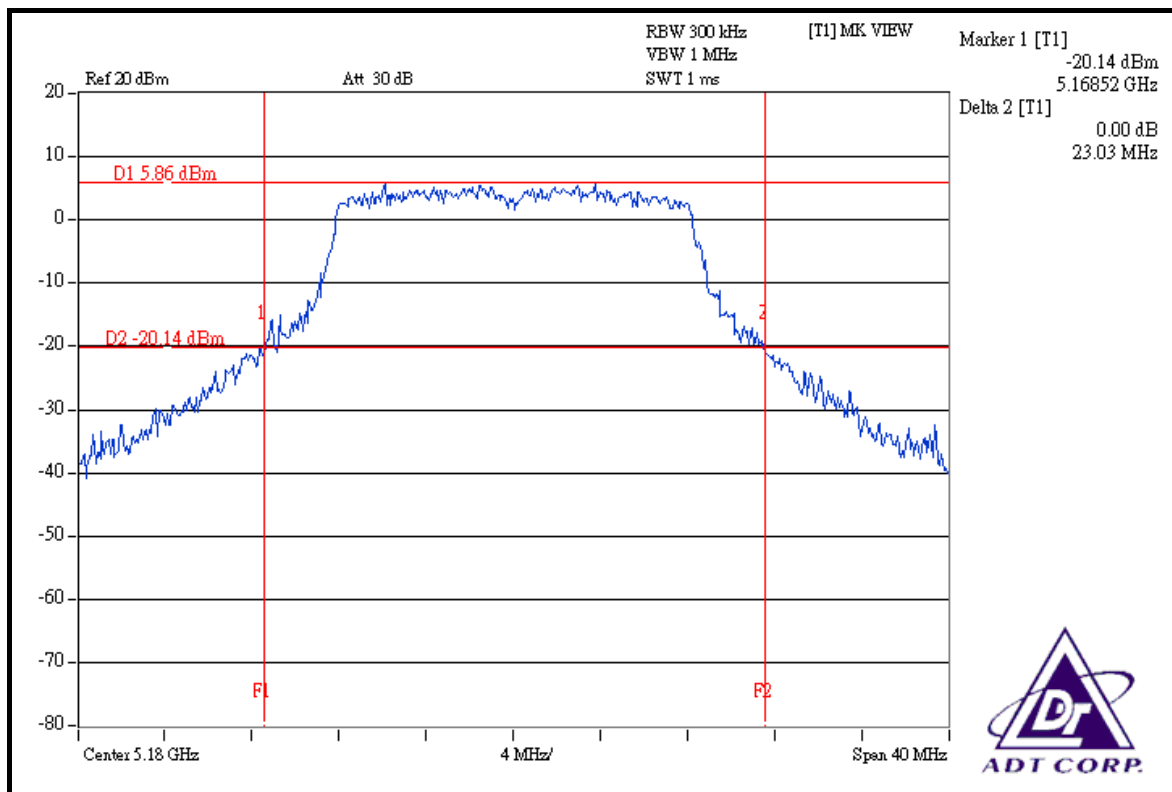

### CH 40

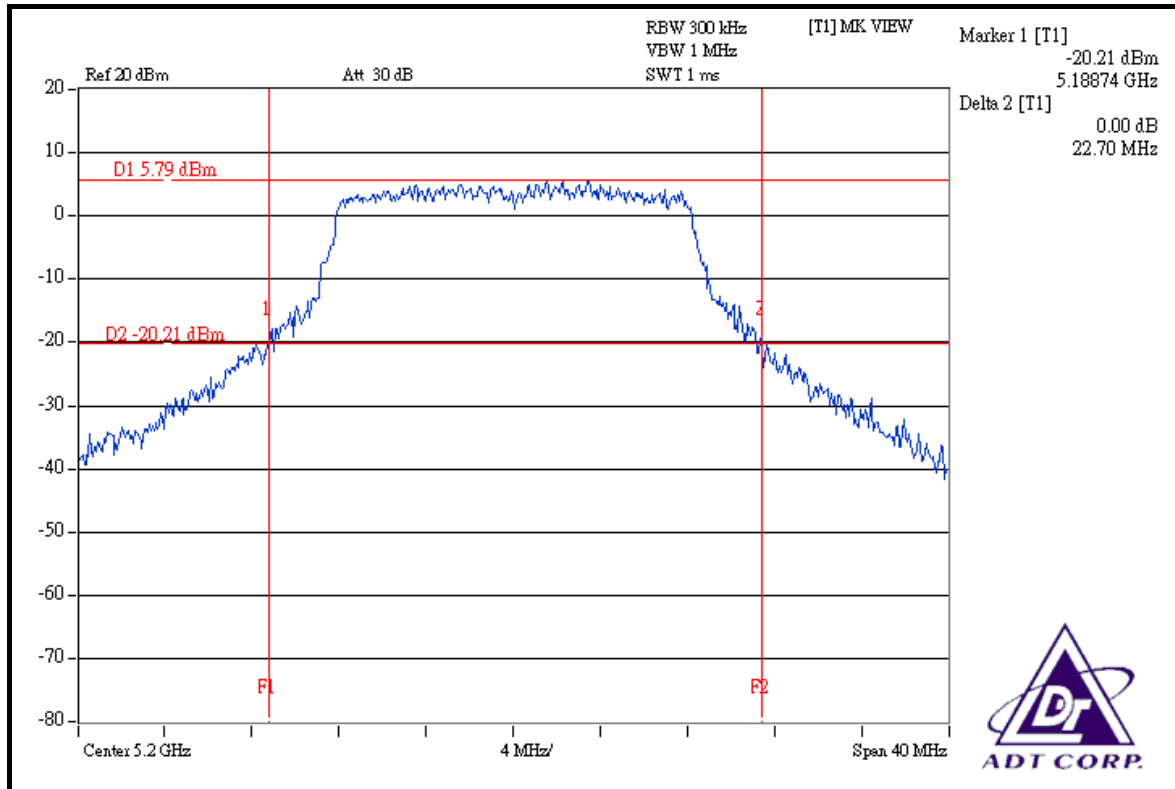

### CH 48

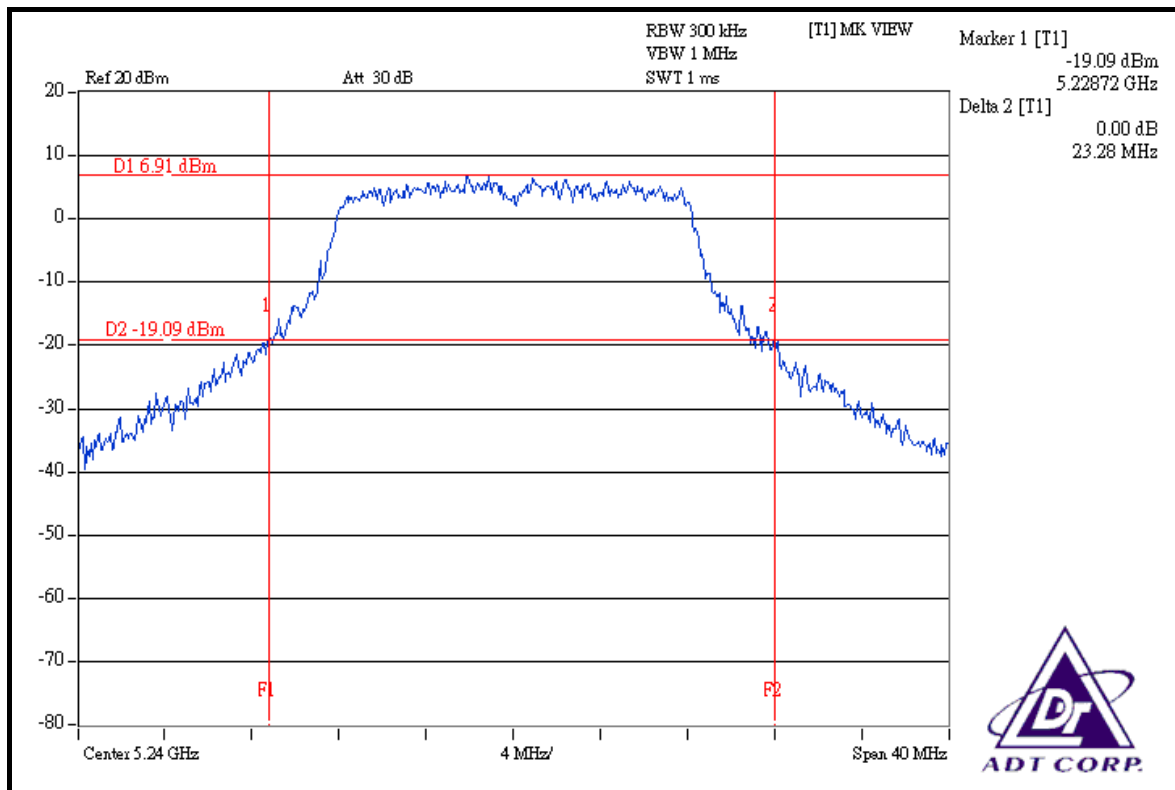



**DRAFT 802.11n (20MHz) OFDM MODULATION**

|                             |              |                                 |                          |
|-----------------------------|--------------|---------------------------------|--------------------------|
| <b>MODULATION TYPE</b>      | BPSK         | <b>TRANSFER RATE</b>            | 7.2Mbps                  |
| <b>INPUT POWER (SYSTEM)</b> | 120Vac, 60Hz | <b>ENVIRONMENTAL CONDITIONS</b> | 26 deg.C, 67 %RH, 991hPa |
| <b>TESTED BY</b>            | Dean Wang    |                                 |                          |

| CHANNEL | CHANNEL FREQUENCY (MHz) | 26dBc OCCUPIED BANDWIDTH (MHz) |         |         | PASS / FAIL |
|---------|-------------------------|--------------------------------|---------|---------|-------------|
|         |                         | CHAIN 0                        | CHAIN 1 | CHAIN 2 |             |
| 36      | 5180                    | 23.45                          | 23.41   | 23.59   | PASS        |
| 40      | 5200                    | 24.32                          | 23.00   | 23.56   | PASS        |
| 48      | 5240                    | 23.50                          | 24.27   | 23.78   | PASS        |

**FOR CHAIN 0: CH 36**

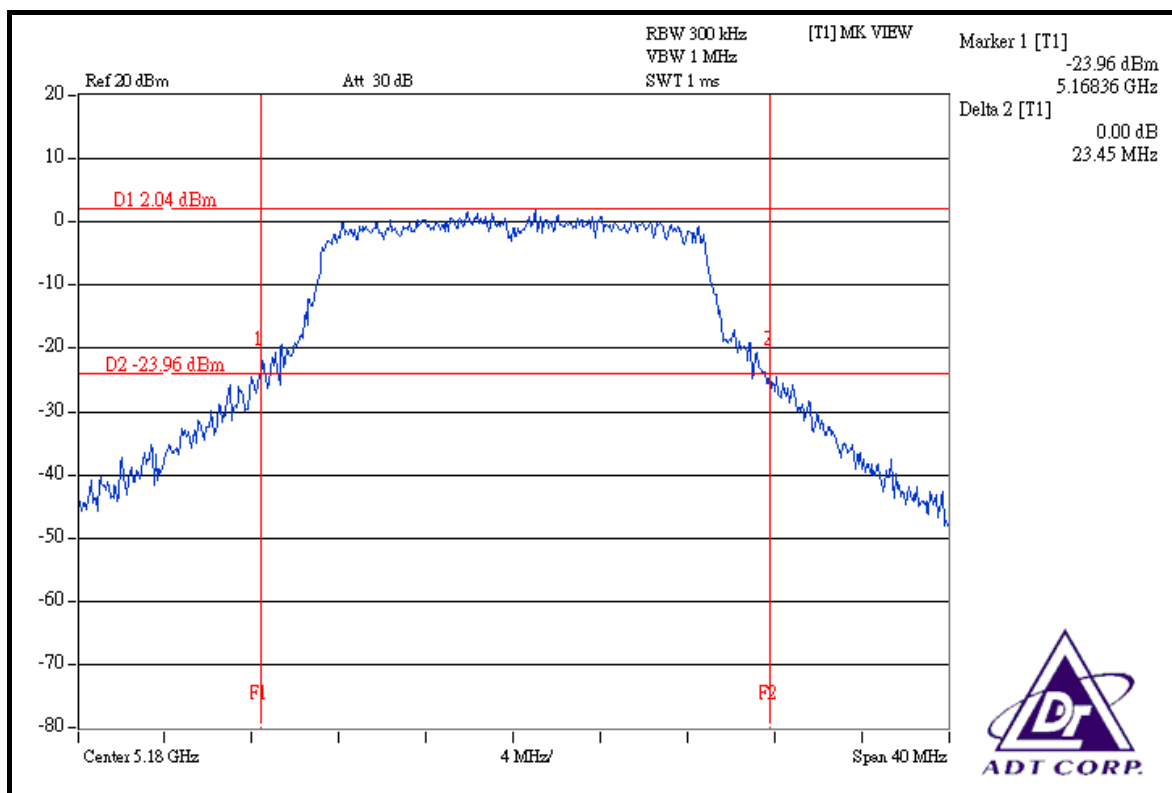

### CH 40

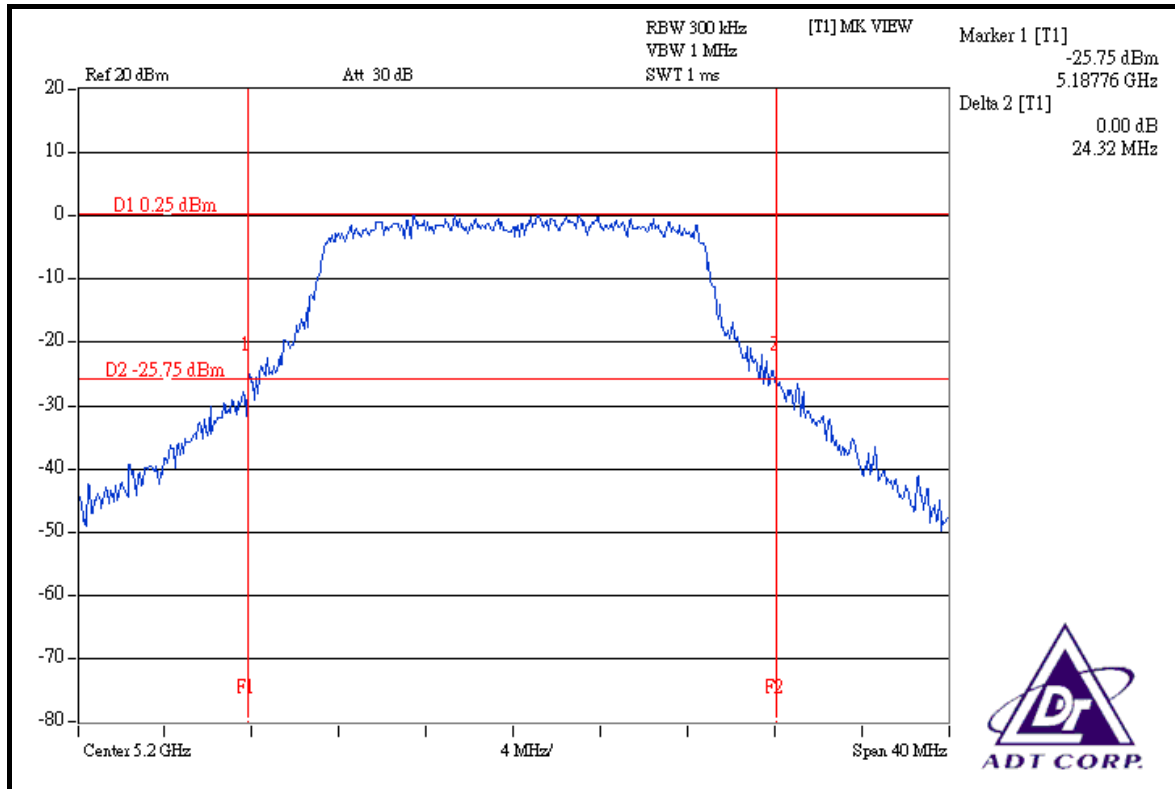

### CH 48

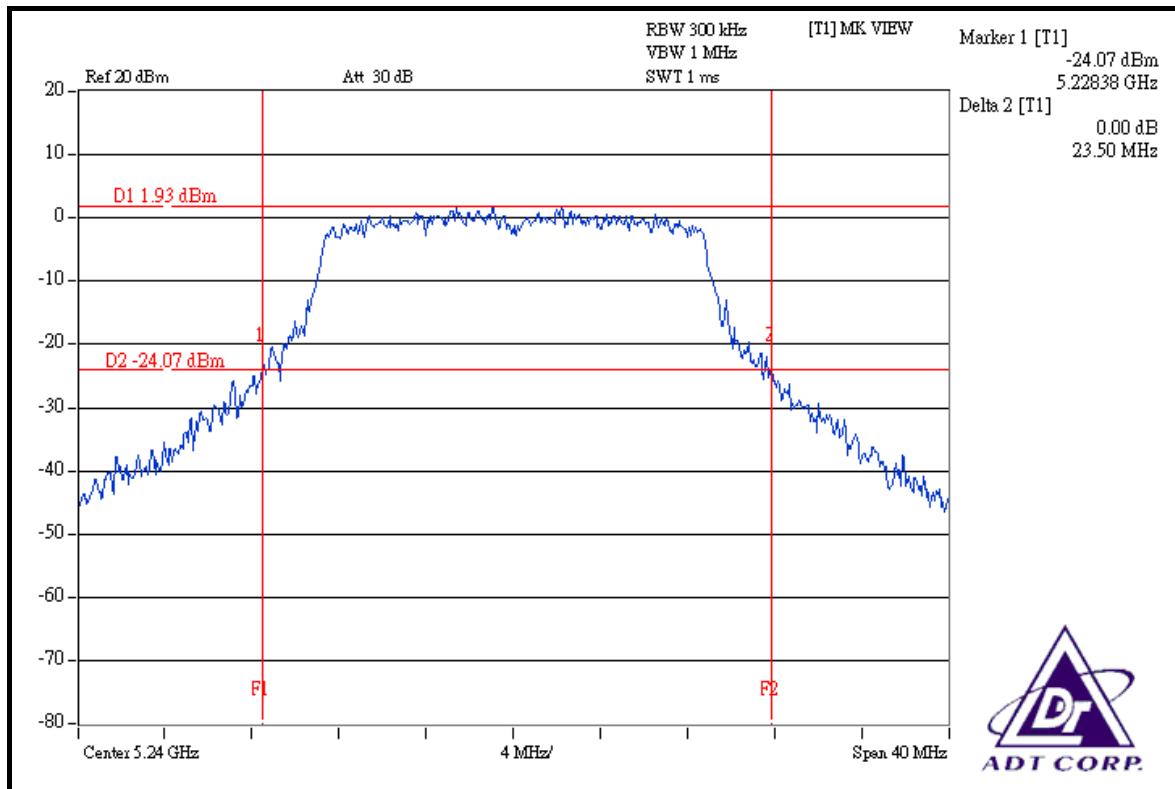



### FOR CHAIN 1: CH 36

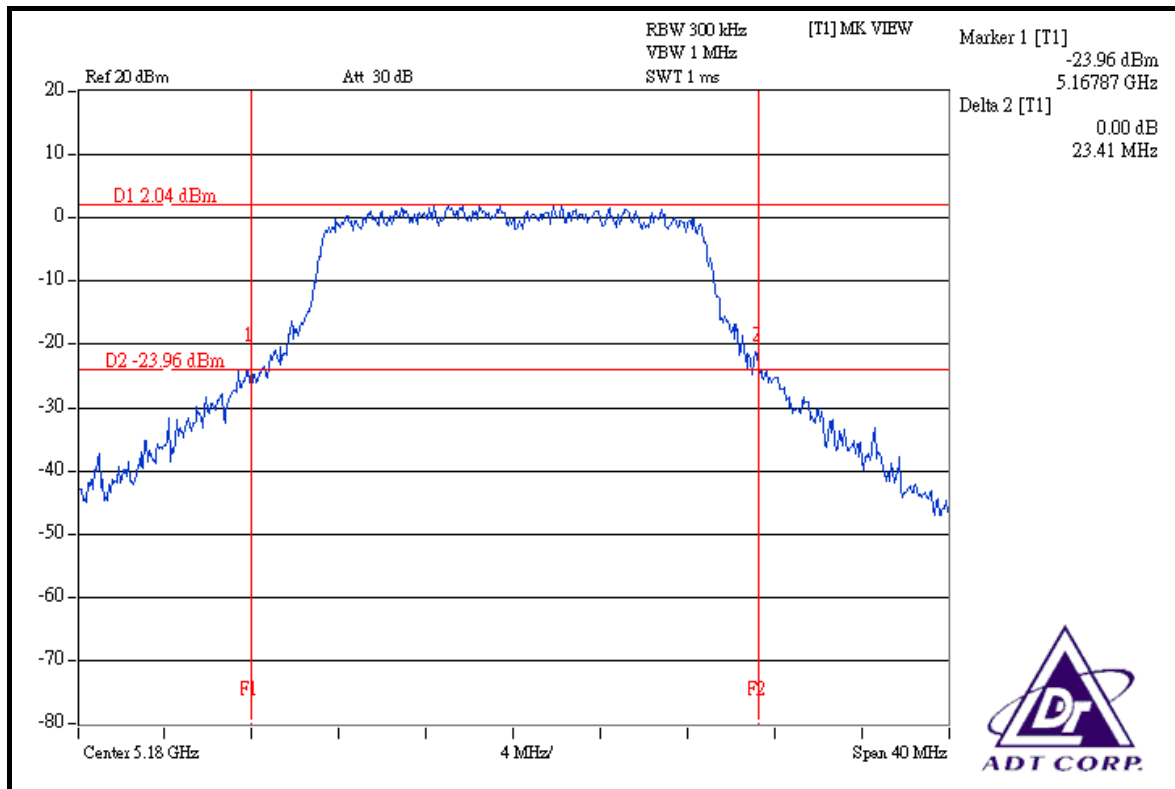

### CH 40

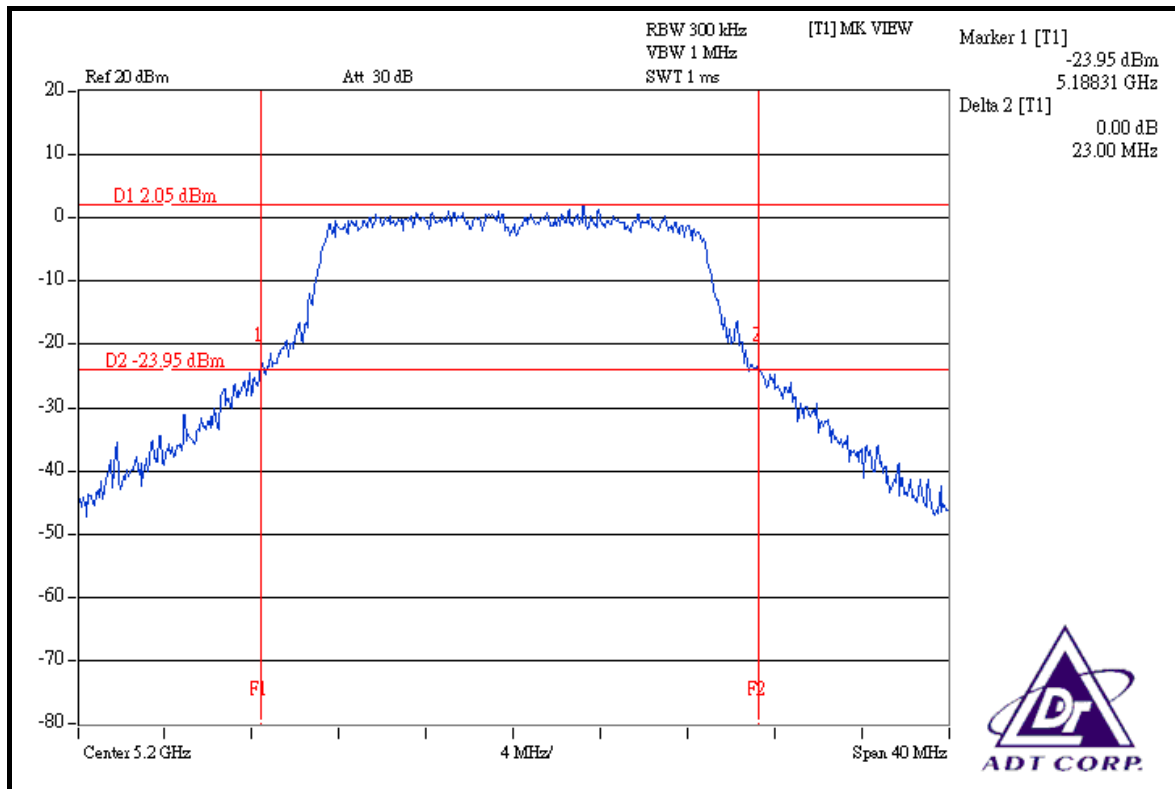



### CH 48

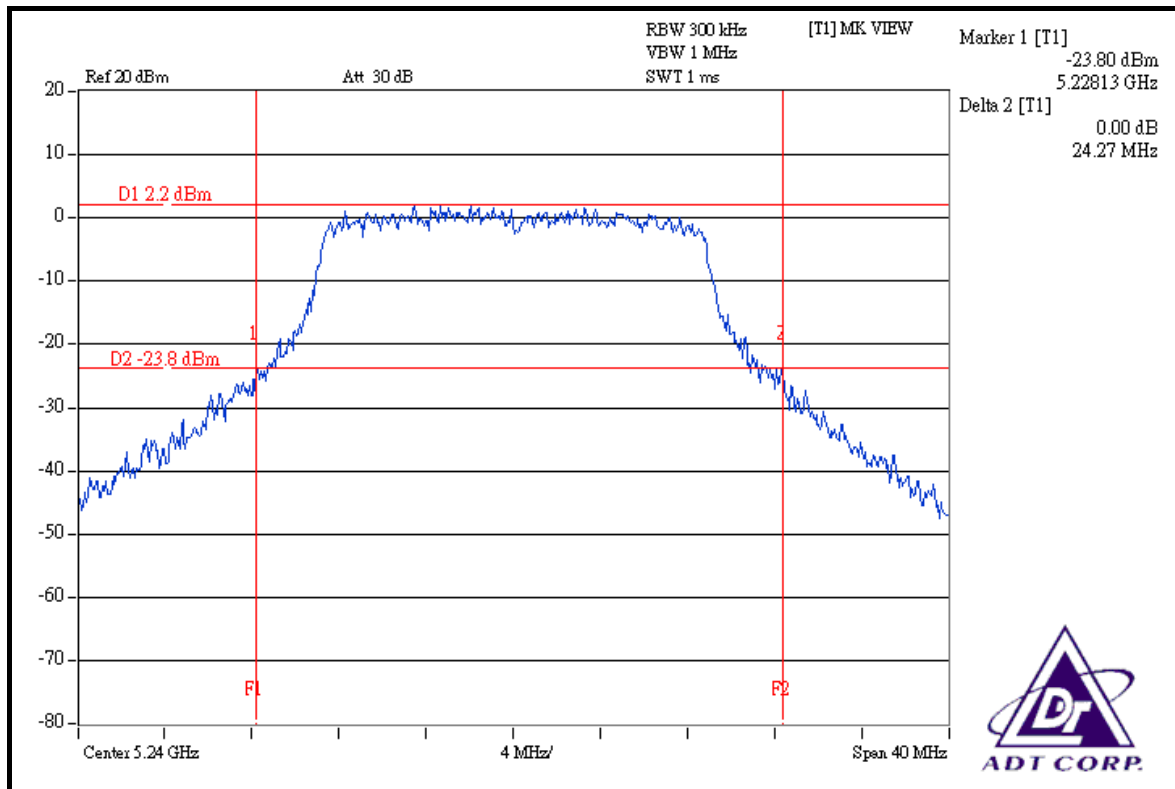

### FOR CHAIN 2: CH 36

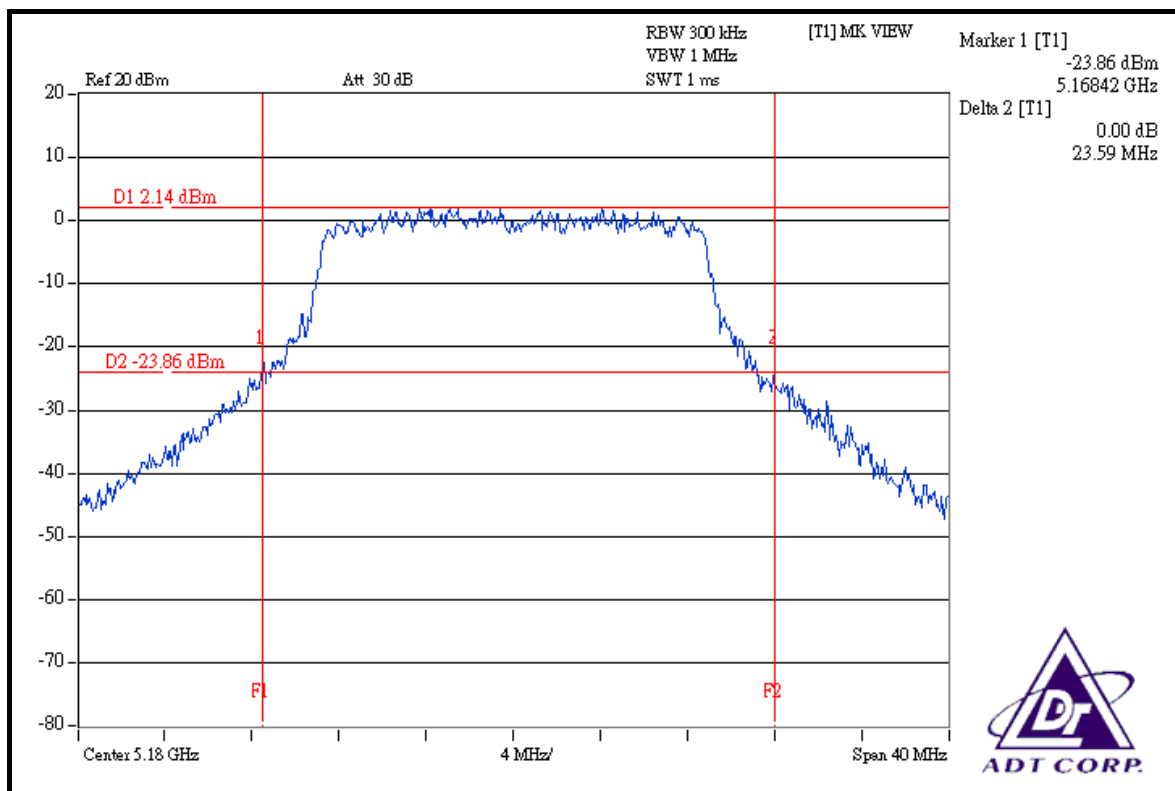



### CH 40

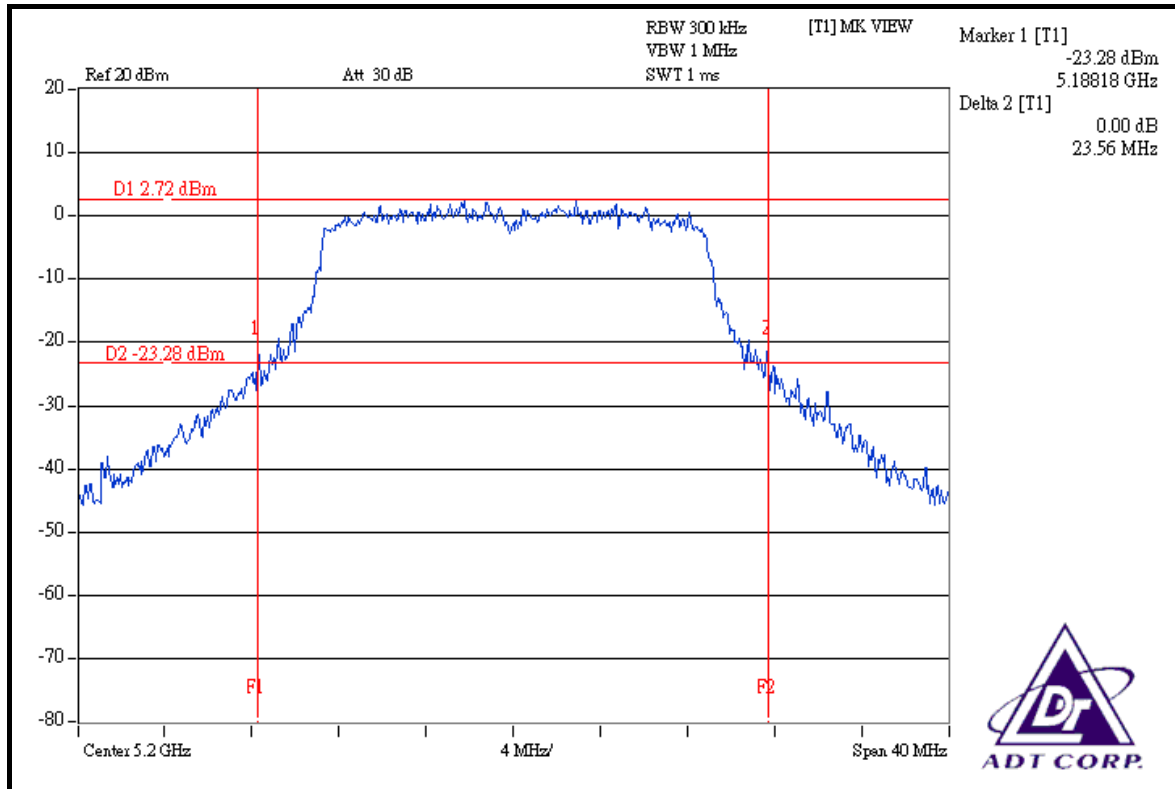

### CH 48

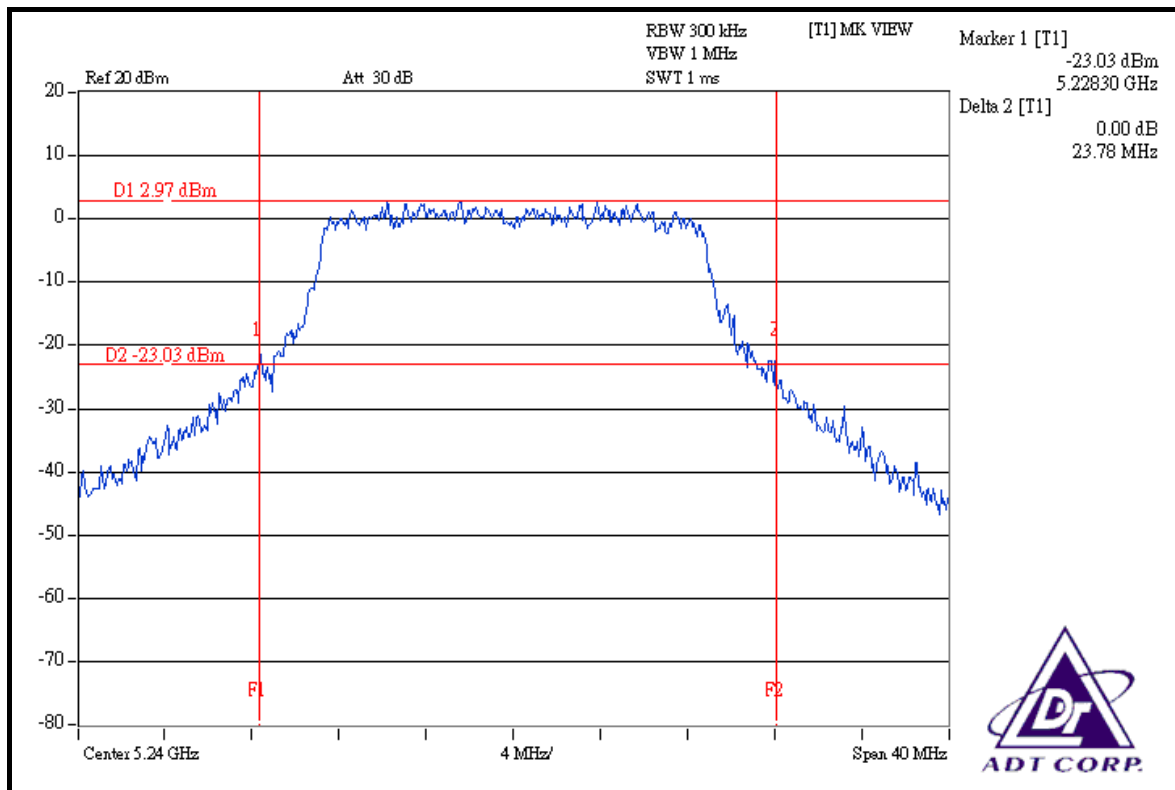



**DRAFT 802.11n (40MHz) OFDM MODULATION**

|                             |              |                                 |                          |
|-----------------------------|--------------|---------------------------------|--------------------------|
| <b>MODULATION TYPE</b>      | BPSK         | <b>TRANSFER RATE</b>            | 15Mbps                   |
| <b>INPUT POWER (SYSTEM)</b> | 120Vac, 60Hz | <b>ENVIRONMENTAL CONDITIONS</b> | 26 deg.C, 67 %RH, 991hPa |
| <b>TESTED BY</b>            | Dean Wang    |                                 |                          |

| CHANNEL | CHANNEL FREQUENCY (MHz) | 26dBc OCCUPIED BANDWIDTH (MHz) |         |         | PASS / FAIL |
|---------|-------------------------|--------------------------------|---------|---------|-------------|
|         |                         | CHAIN 0                        | CHAIN 1 | CHAIN 2 |             |
| 38      | 5190                    | 45.00                          | 44.85   | 44.07   | PASS        |
| 46      | 5230                    | 44.24                          | 44.50   | 42.65   | PASS        |



### FOR CHAIN 0: CH 38

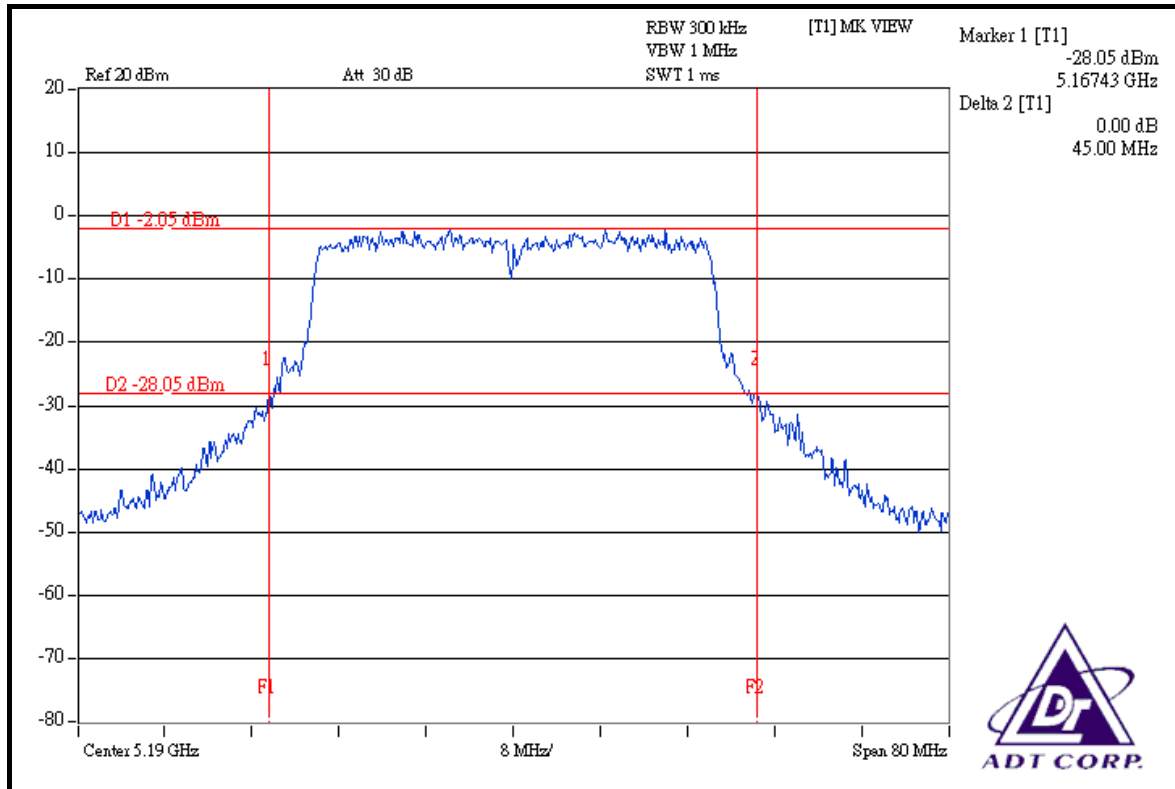

### CH 46

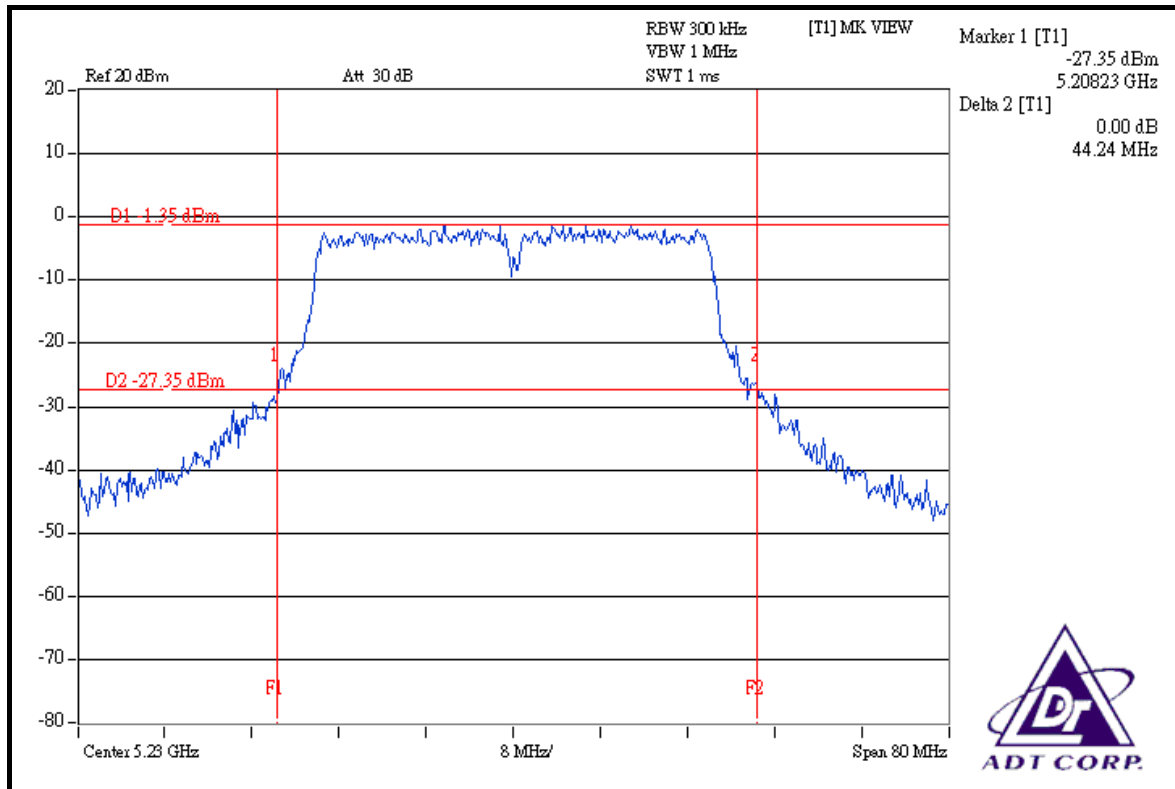



### FOR CHAIN 1: CH 38

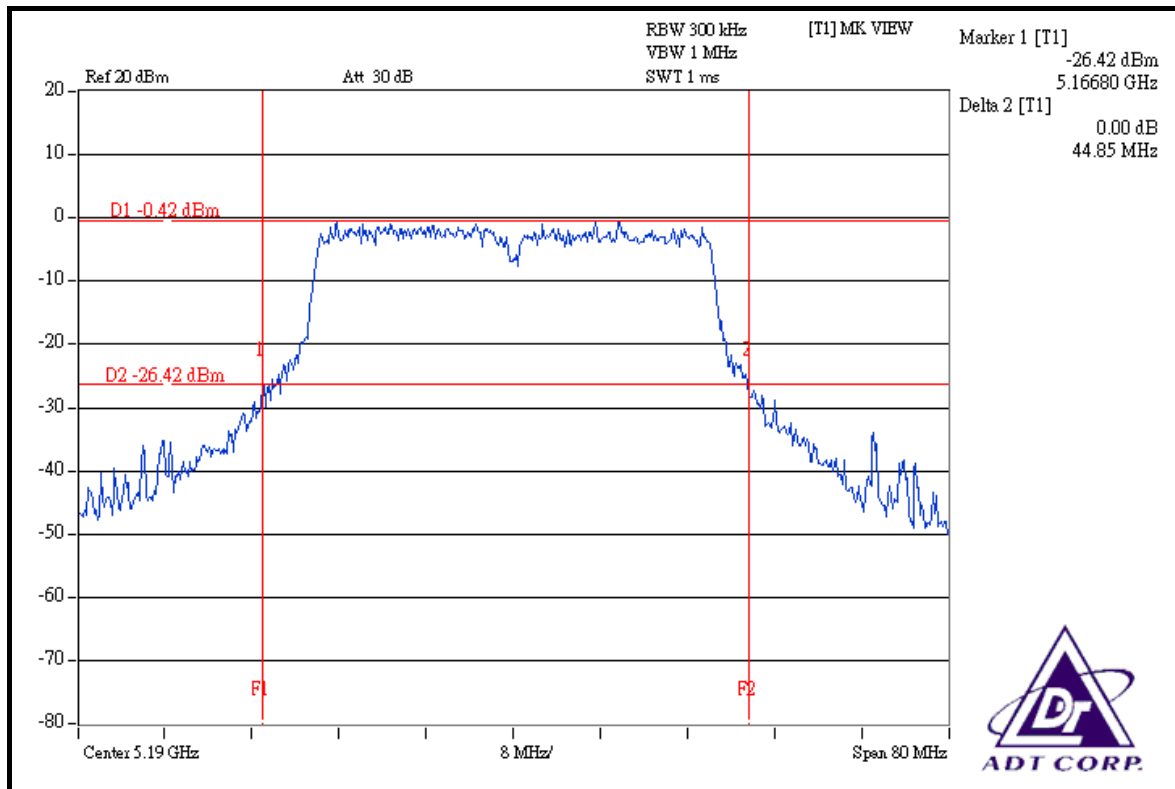

### CH 46

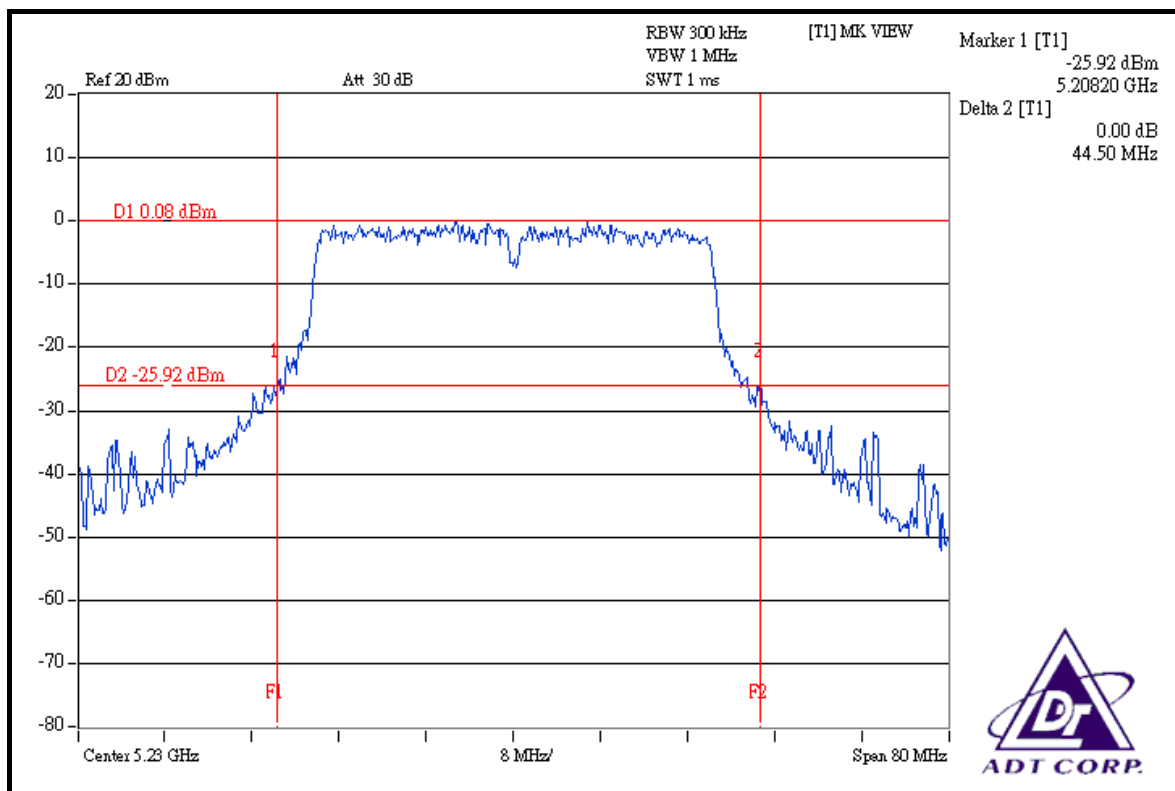



### FOR CHAIN 2: CH 38

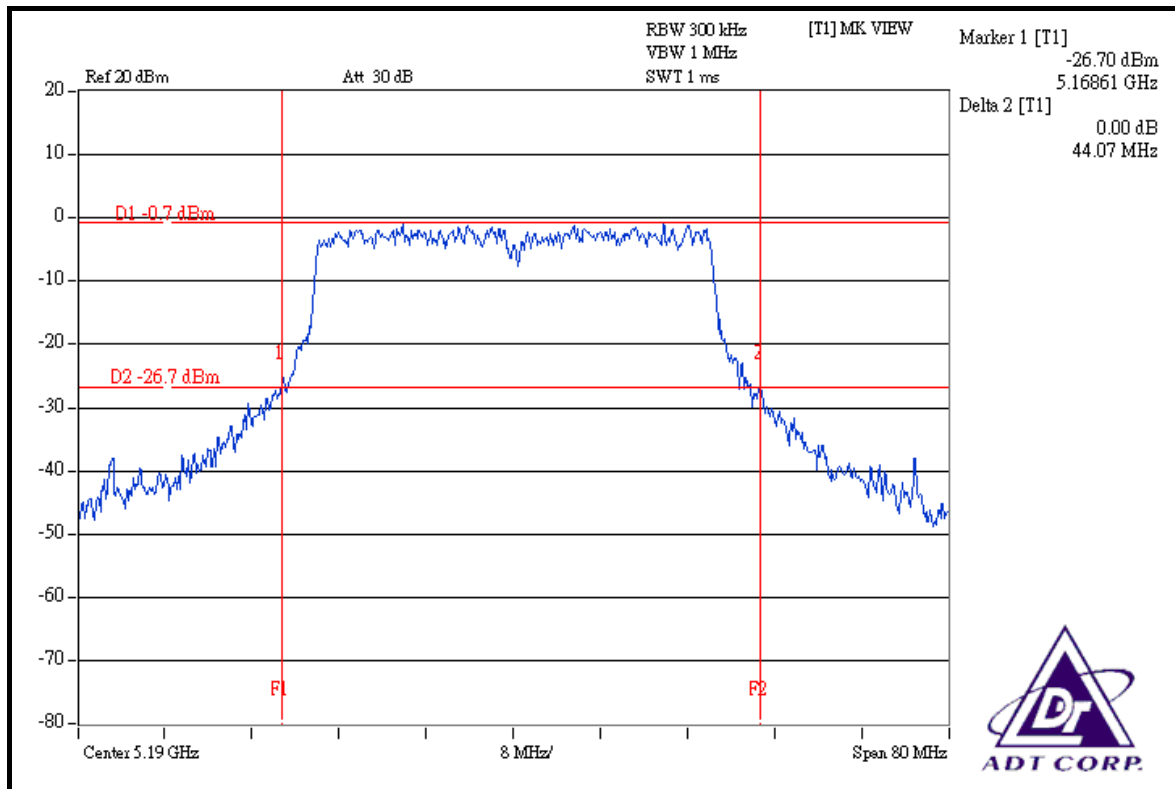

### CH 46

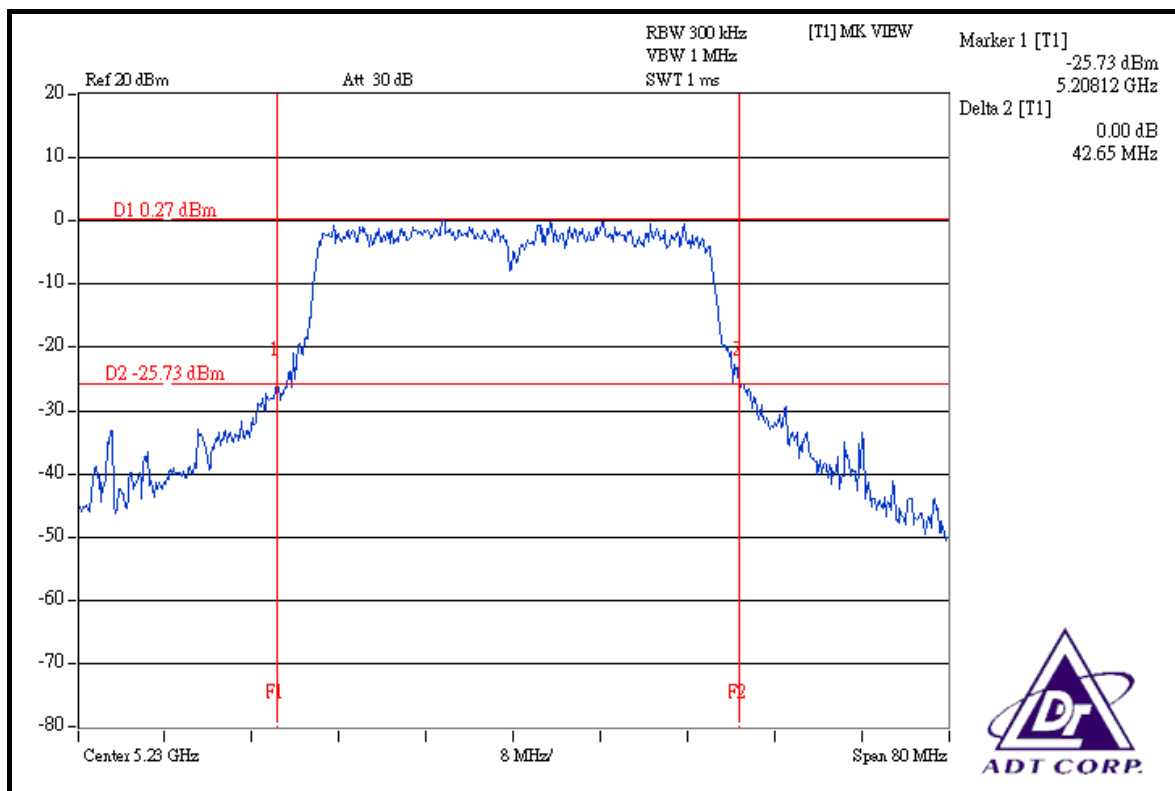



#### 4.4 PEAK POWER EXCURSION MEASUREMENT

##### 4.4.1 LIMITS OF PEAK POWER EXCURSION MEASUREMENT

| FREQUENCY BAND | LIMIT |
|----------------|-------|
| 5.15 ~ 5.25GHz | 13dB  |

##### 4.4.2 TEST INSTRUMENTS

| DESCRIPTION & MANUFACTURER | MODEL NO. | SERIAL NO. | CALIBRATED UNTIL |
|----------------------------|-----------|------------|------------------|
| R&S SPECTRUM ANALYZER      | FSP40     | 100040     | Jun. 28, 2008    |

**NOTE:** The calibration interval of the above test instruments is 12 months and the calibrations are traceable to NML/ROC and NIST/USA.

##### 4.4.3 TEST PROCEDURE

- a. The transmitter output was connected to the spectrum analyzer.
- b. Set the spectrum bandwidth span to view the entire spectrum.
- c. Using peak detector and Max-hold function for Trace 1 (RB = 1MHz, VB = 3MHz) and 2 (RB = 1MHz, VB = 300kHz).
- d. The largest difference between Trace 1 and Trace 2 in any 1MHz band on any frequency was recorded.

#### 4.4.4 DEVIATION FROM TEST STANDARD

No deviation

#### 4.4.5 TEST SETUP

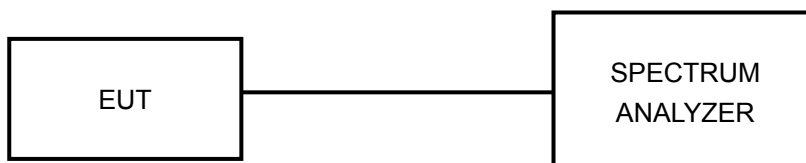

#### 4.4.6 EUT OPERATING CONDITIONS

The software provided by client to enable the EUT under transmission condition continuously at specific channel frequencies individually.







### CH 40

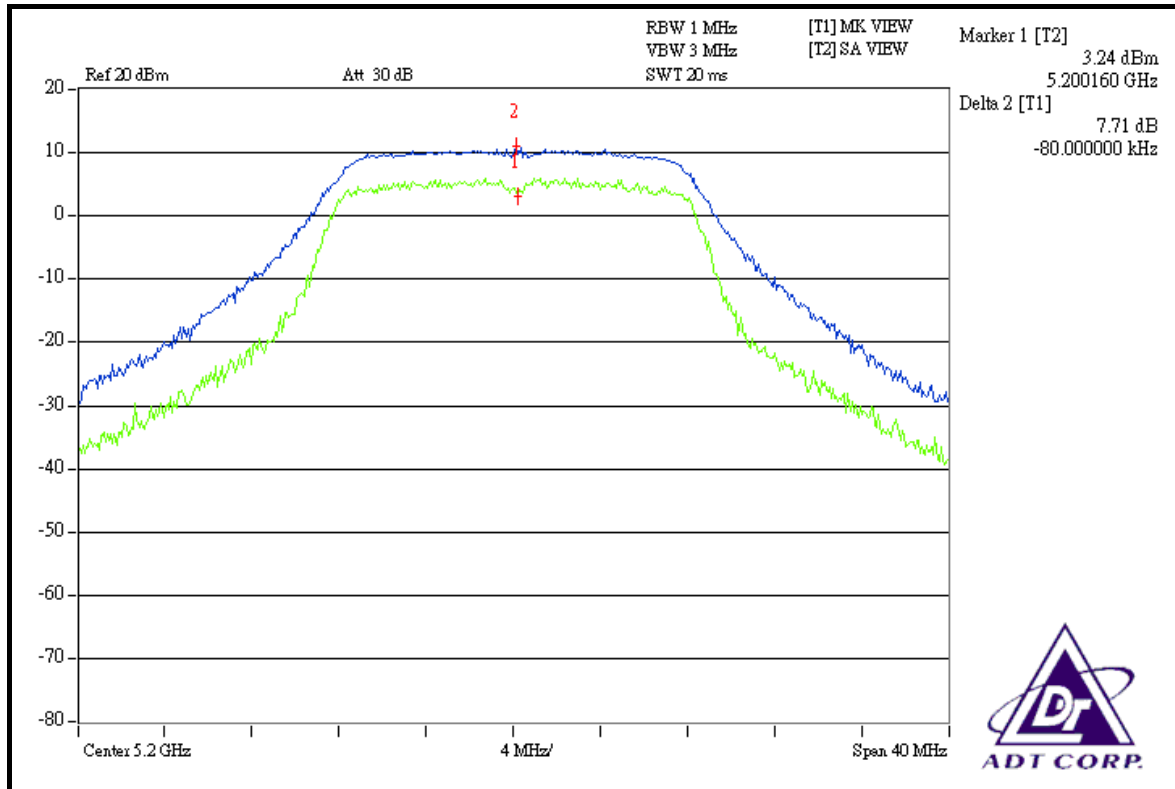

### CH 48

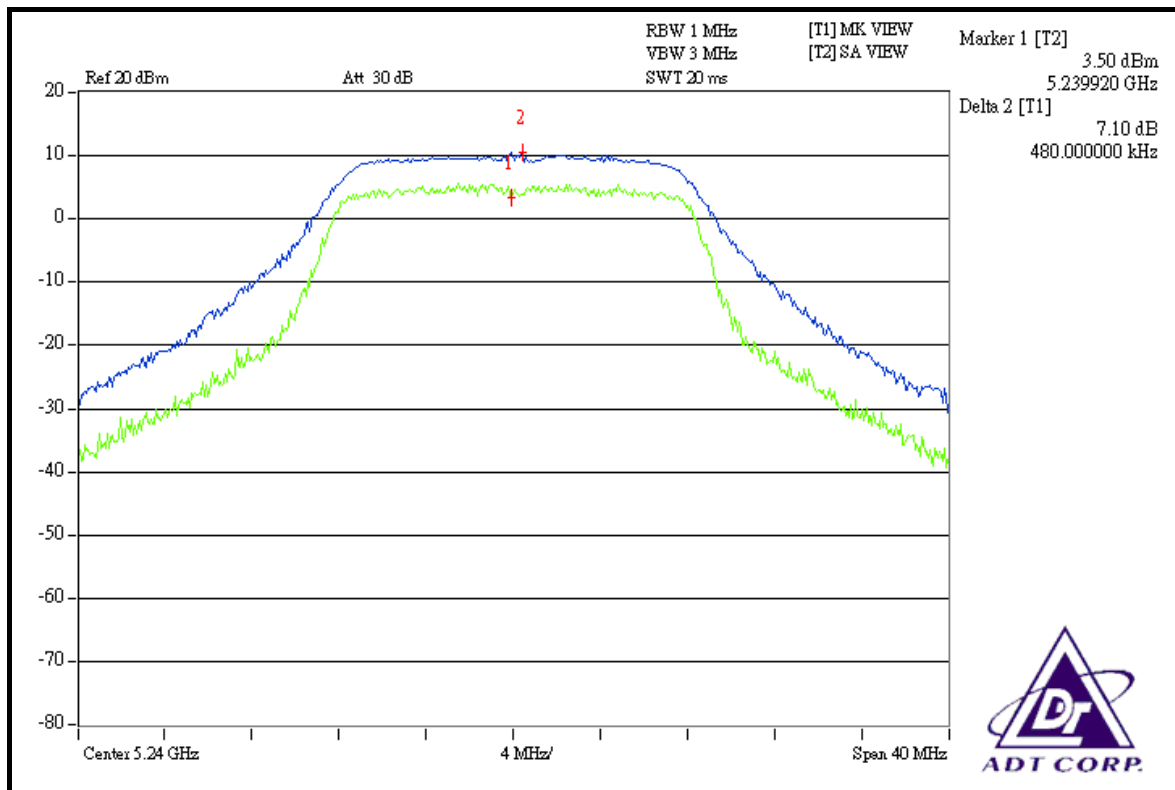



**DRAFT 802.11n (20MHz) OFDM MODULATION**

|                             |              |                                 |                          |
|-----------------------------|--------------|---------------------------------|--------------------------|
| <b>MODULATION TYPE</b>      | BPSK         | <b>TRANSFER RATE</b>            | 7.2Mbps                  |
| <b>INPUT POWER (SYSTEM)</b> | 120Vac, 60Hz | <b>ENVIRONMENTAL CONDITIONS</b> | 26 deg.C, 67 %RH, 991hPa |
| <b>TESTED BY</b>            | Dean Wang    |                                 |                          |

| CHANNEL | CHANNEL FREQUENCY (MHz) | PEAK POWER EXCURSION (dB) |         |         | PEAK to AVERAGE EXCURSION LIMIT (dB) | PASS/FAIL |
|---------|-------------------------|---------------------------|---------|---------|--------------------------------------|-----------|
|         |                         | CHAIN 0                   | CHAIN 1 | CHAIN 2 |                                      |           |
| 36      | 5180                    | 8.01                      | 7.54    | 9.11    | 13                                   | PASS      |
| 40      | 5200                    | 7.70                      | 7.44    | 9.21    | 13                                   | PASS      |
| 48      | 5240                    | 8.31                      | 7.89    | 8.84    | 13                                   | PASS      |

**FOR CHAIN 0: CH 36**

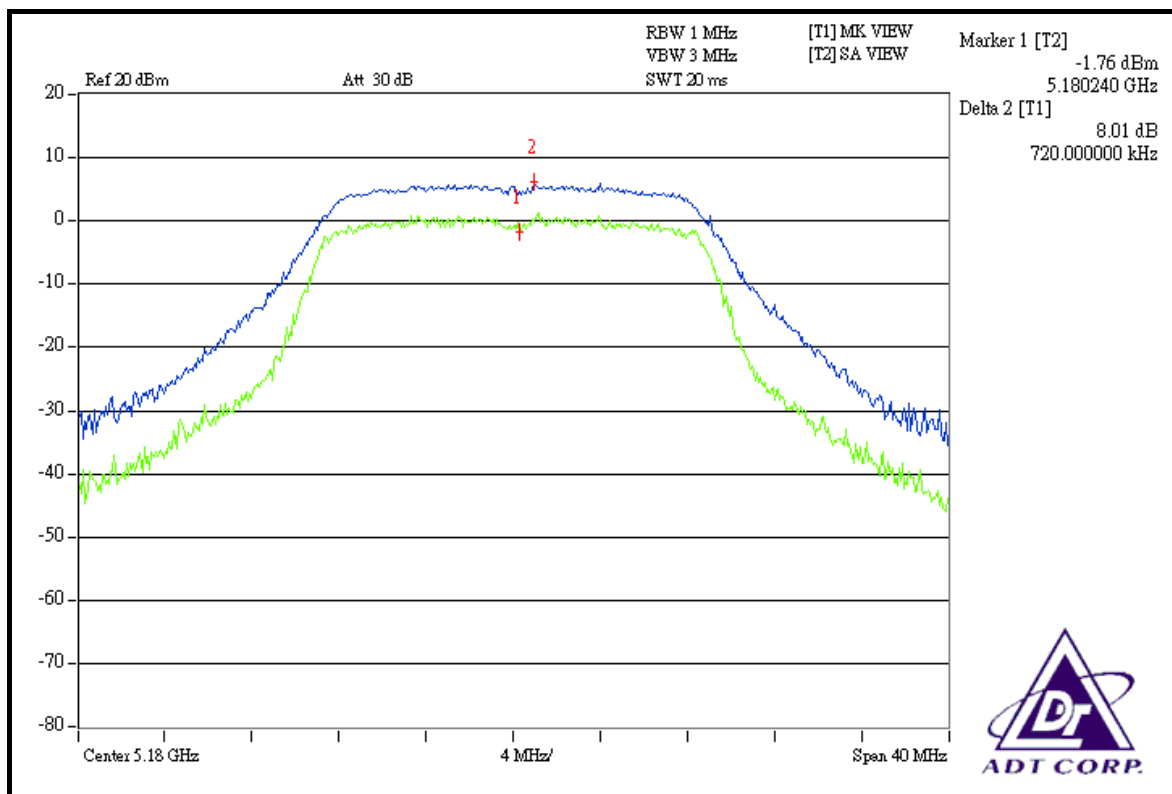



### CH 40

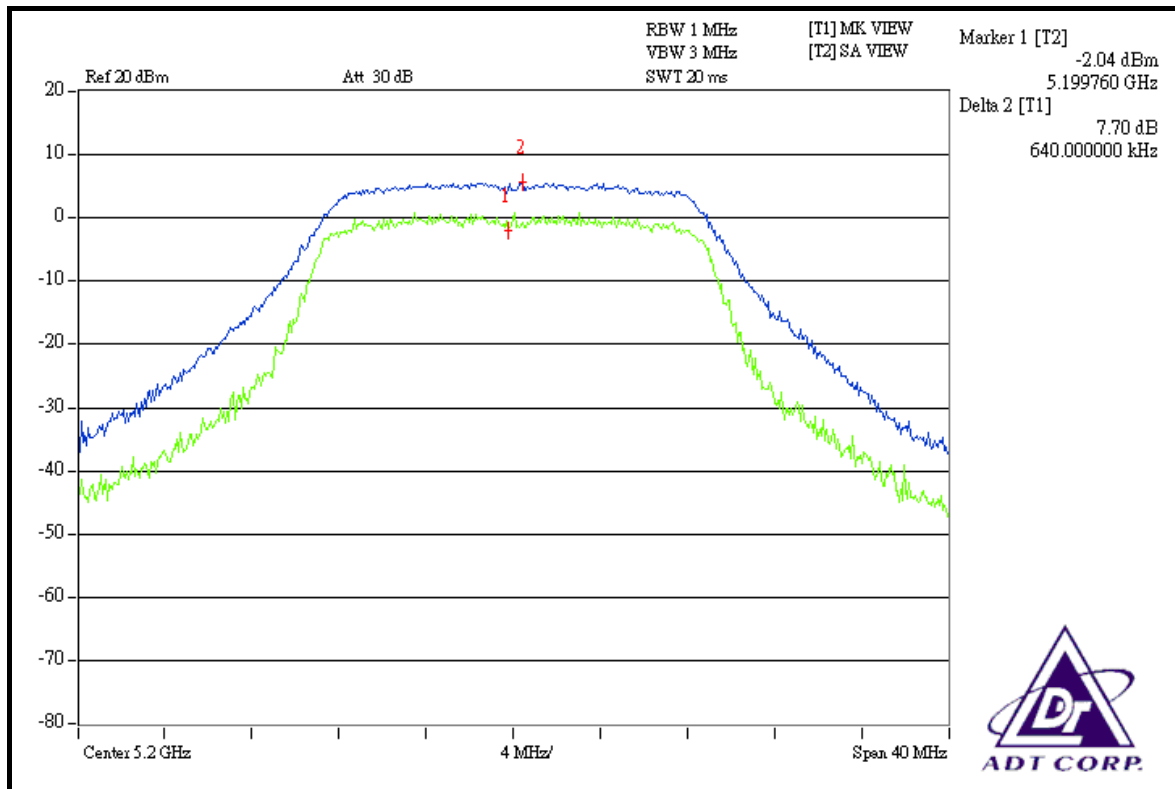

### CH 48

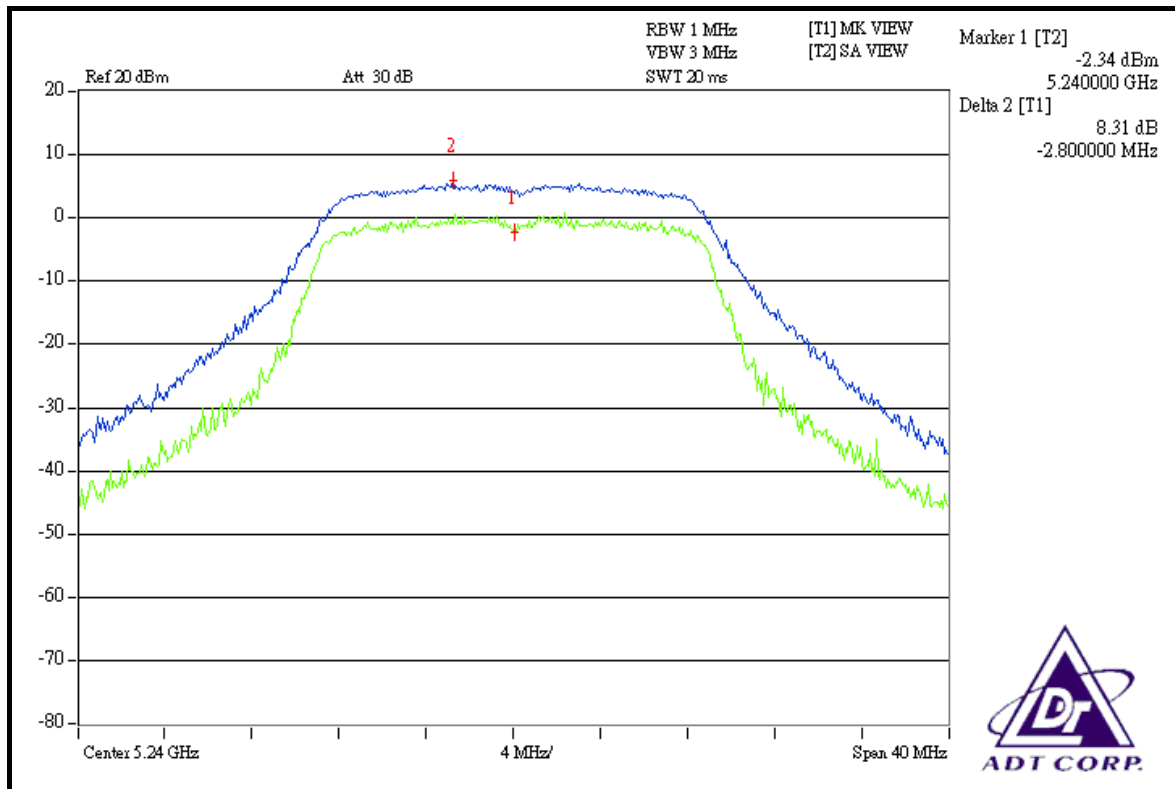



### FOR CHAIN 1: CH 36

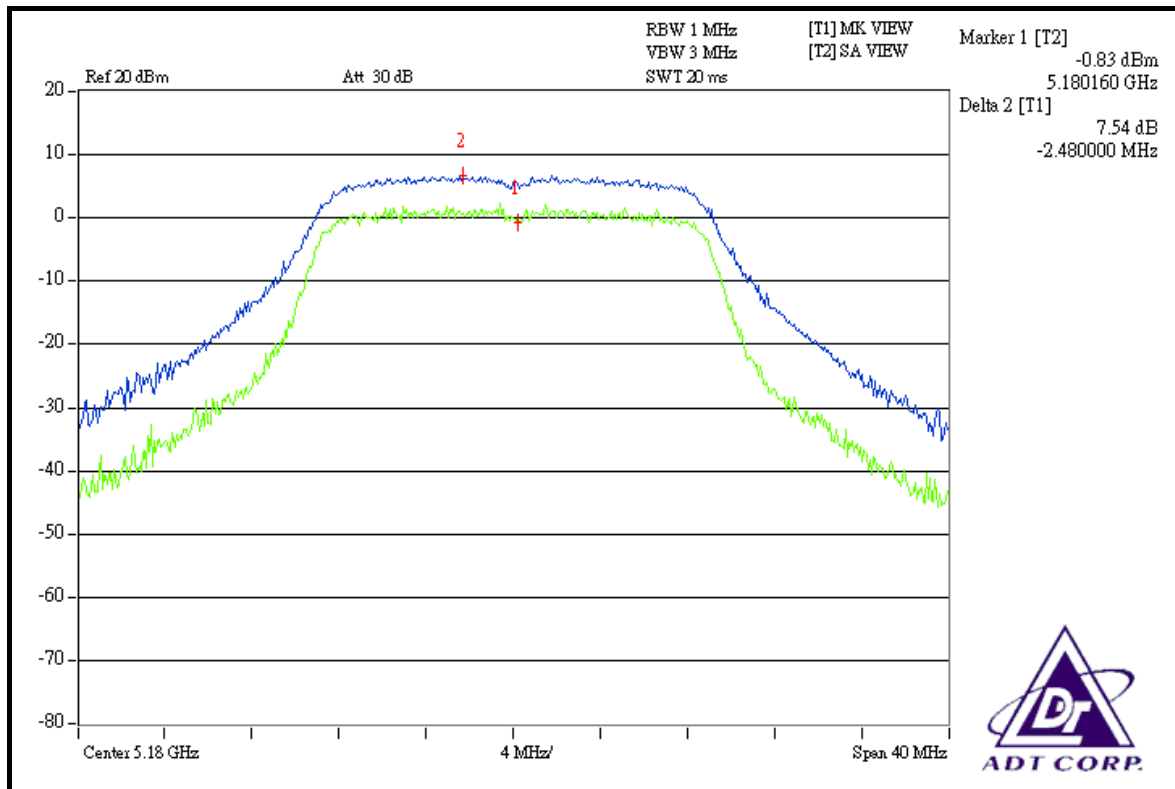

### CH 40

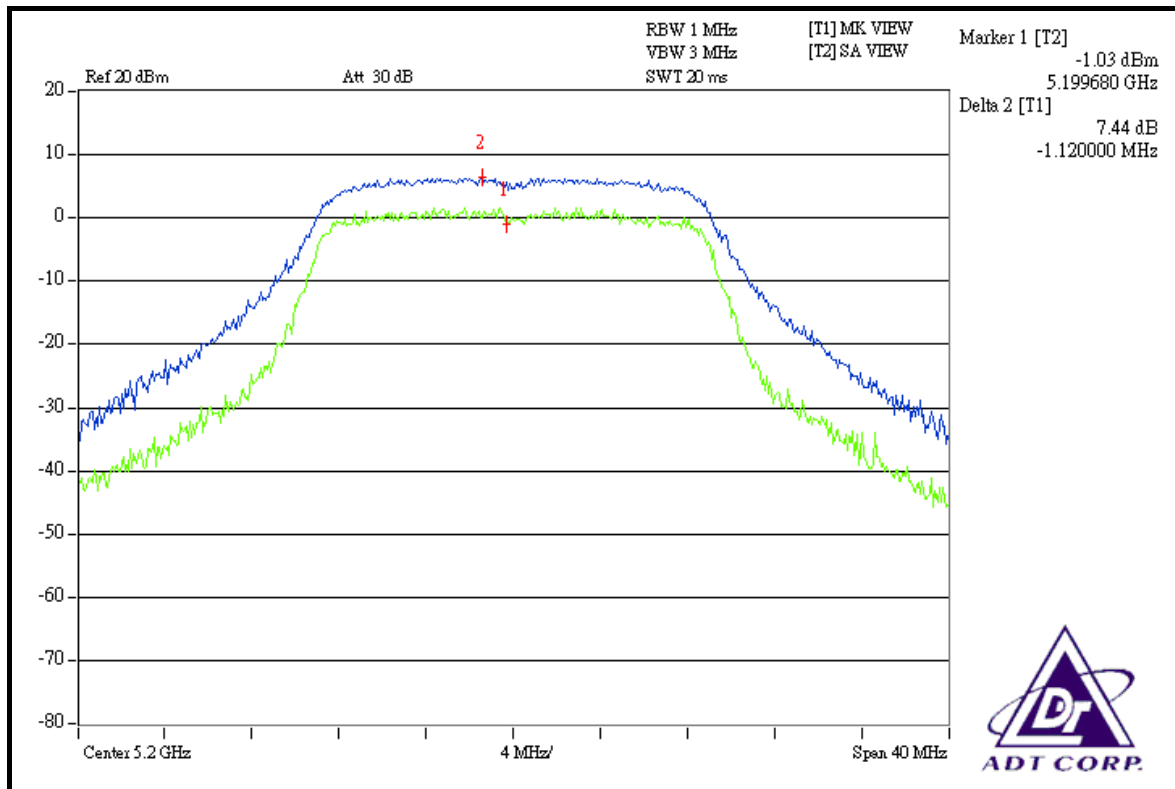



### CH 48

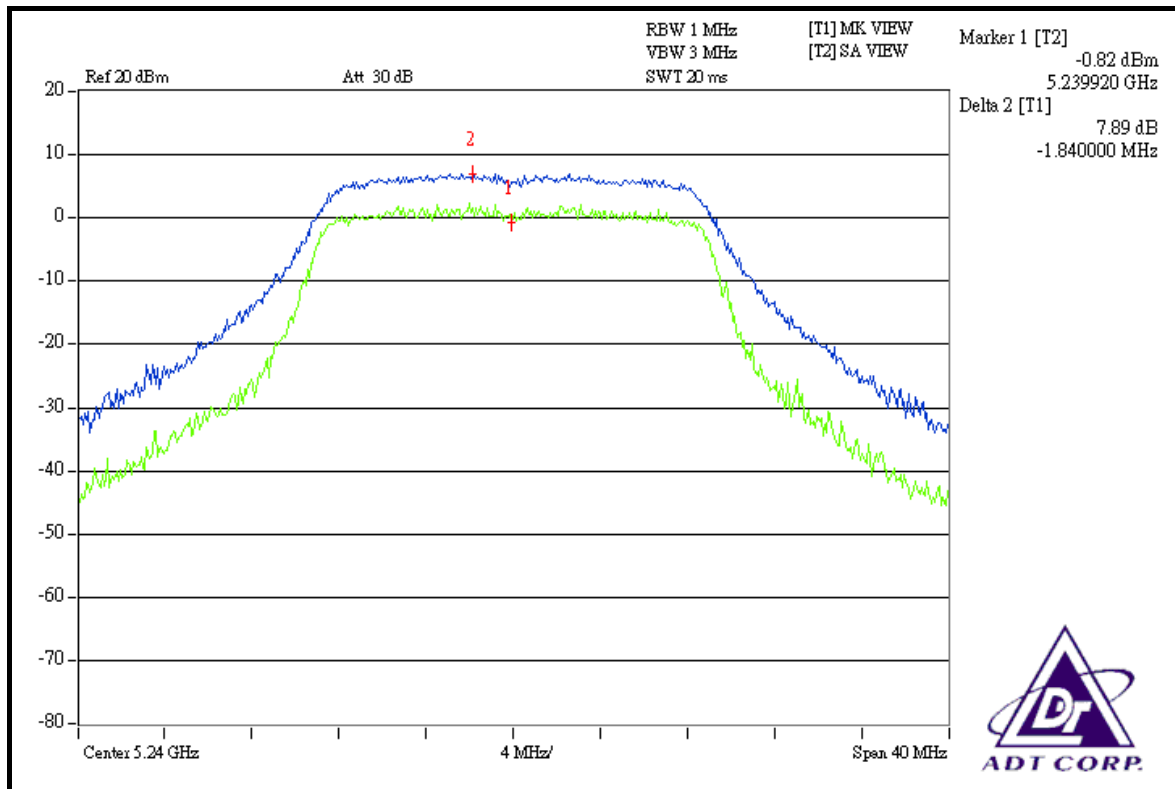

### FOR CHAIN 2: CH 36

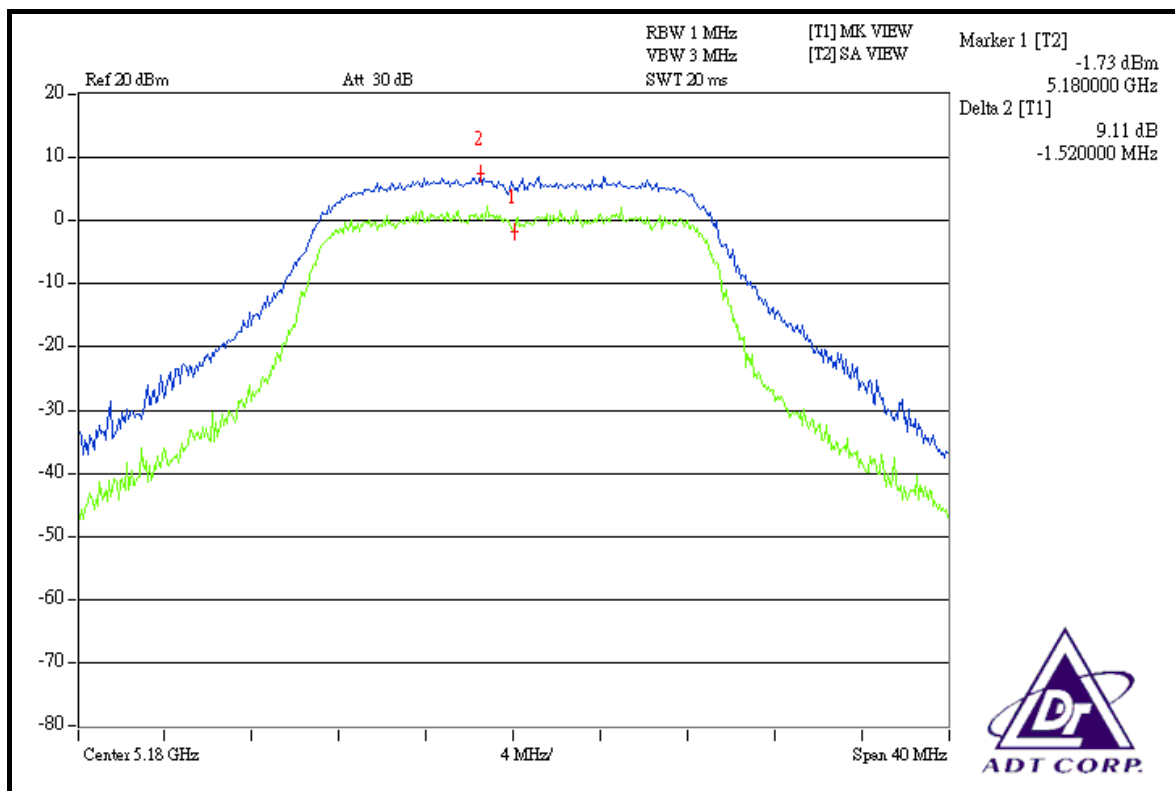



### CH 40

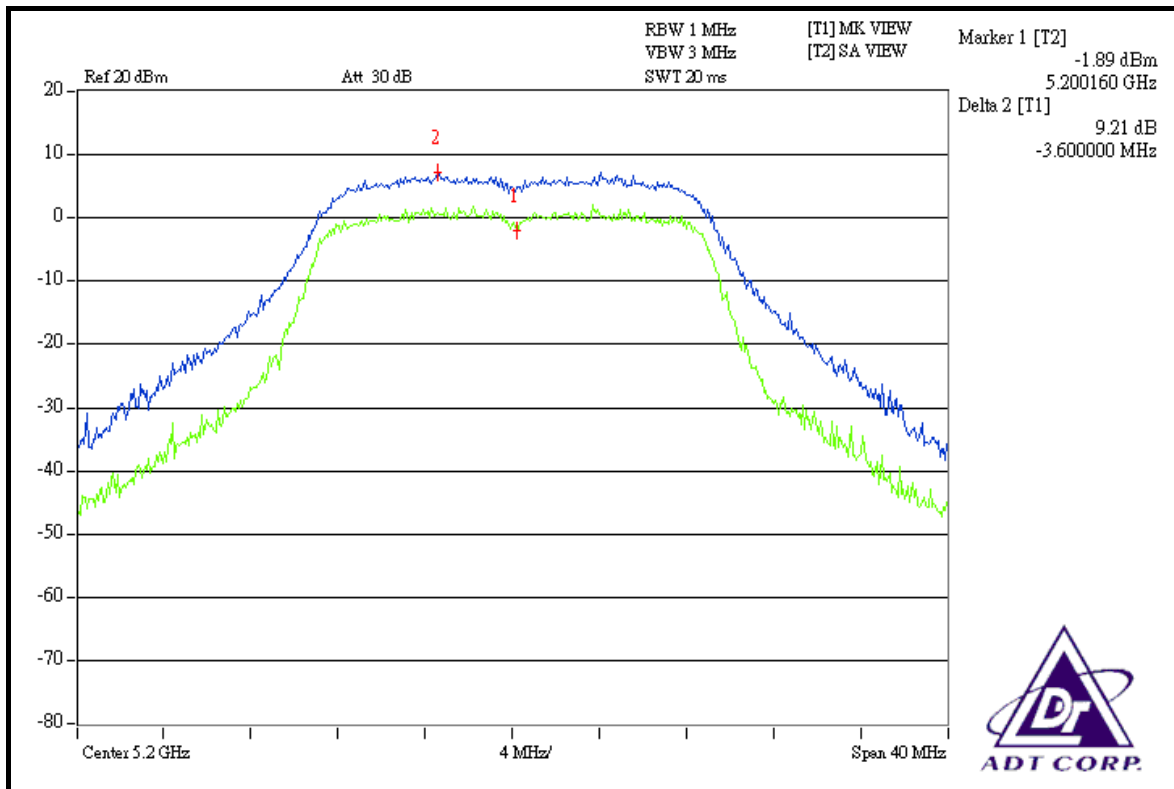

### CH 48

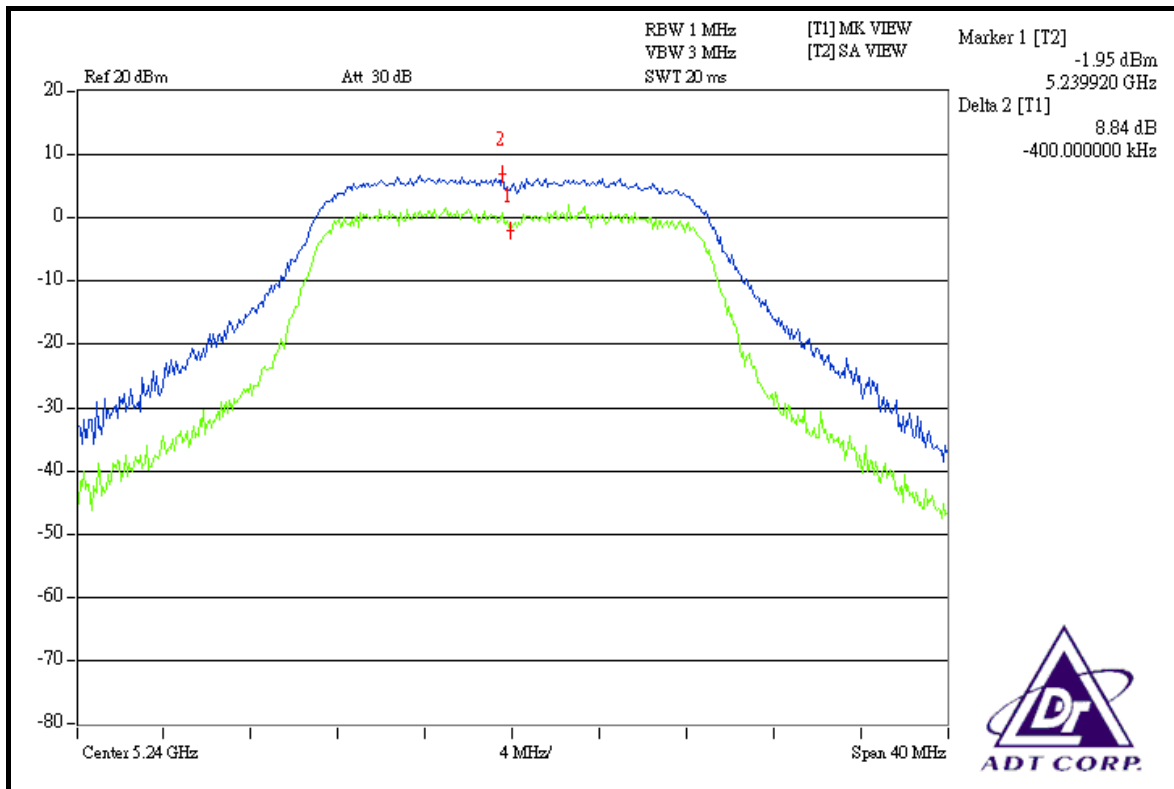



**DRAFT 802.11n (40MHz) OFDM MODULATION**

|                             |              |                                 |                          |
|-----------------------------|--------------|---------------------------------|--------------------------|
| <b>MODULATION TYPE</b>      | BPSK         | <b>TRANSFER RATE</b>            | 15Mbps                   |
| <b>INPUT POWER (SYSTEM)</b> | 120Vac, 60Hz | <b>ENVIRONMENTAL CONDITIONS</b> | 26 deg.C, 67 %RH, 991hPa |
| <b>TESTED BY</b>            | Dean Wang    |                                 |                          |

| CHANNEL | CHANNEL FREQUENCY (MHz) | PEAK POWER EXCURSION (dB) |         |         | PEAK to AVERAGE EXCURSION LIMIT (dB) | PASS/FAIL |
|---------|-------------------------|---------------------------|---------|---------|--------------------------------------|-----------|
|         |                         | CHAIN 0                   | CHAIN 1 | CHAIN 2 |                                      |           |
| 38      | 5190                    | 9.66                      | 10.61   | 10.33   | 13                                   | PASS      |
| 46      | 5230                    | 10.24                     | 10.45   | 10.62   | 13                                   | PASS      |



### FOR CHAIN 0: CH 38

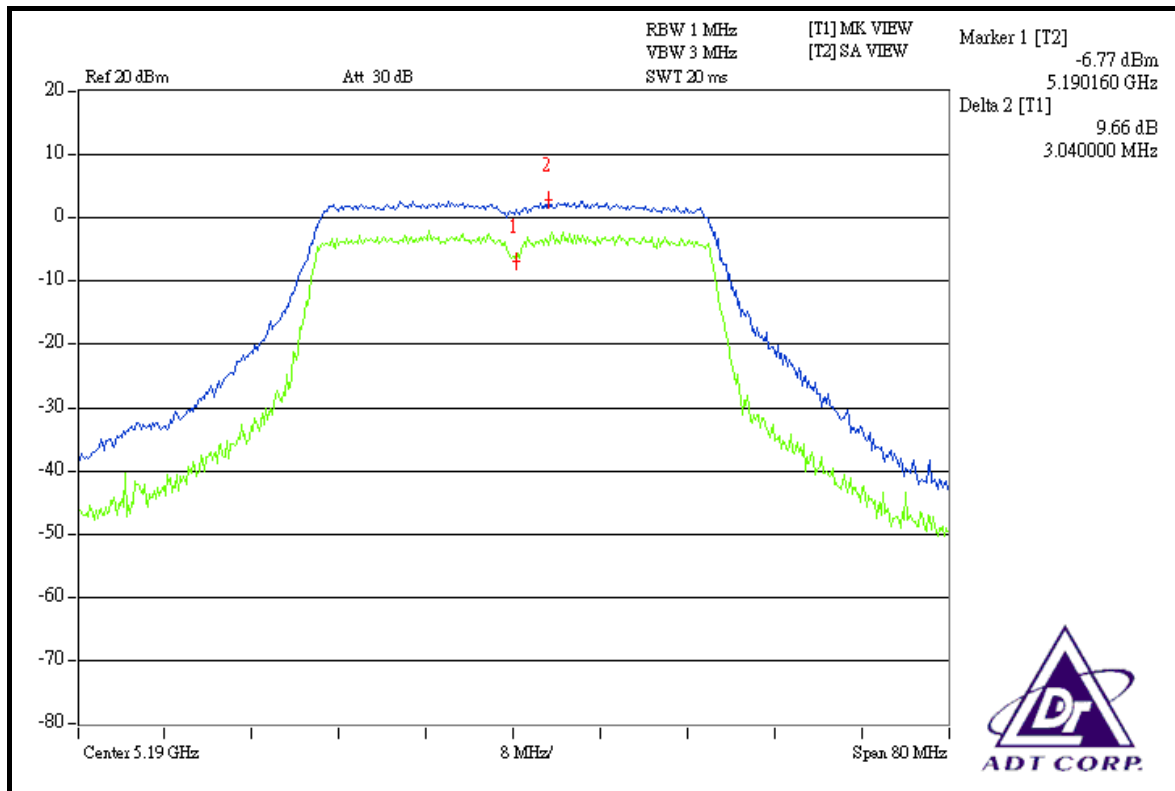

### CH 46

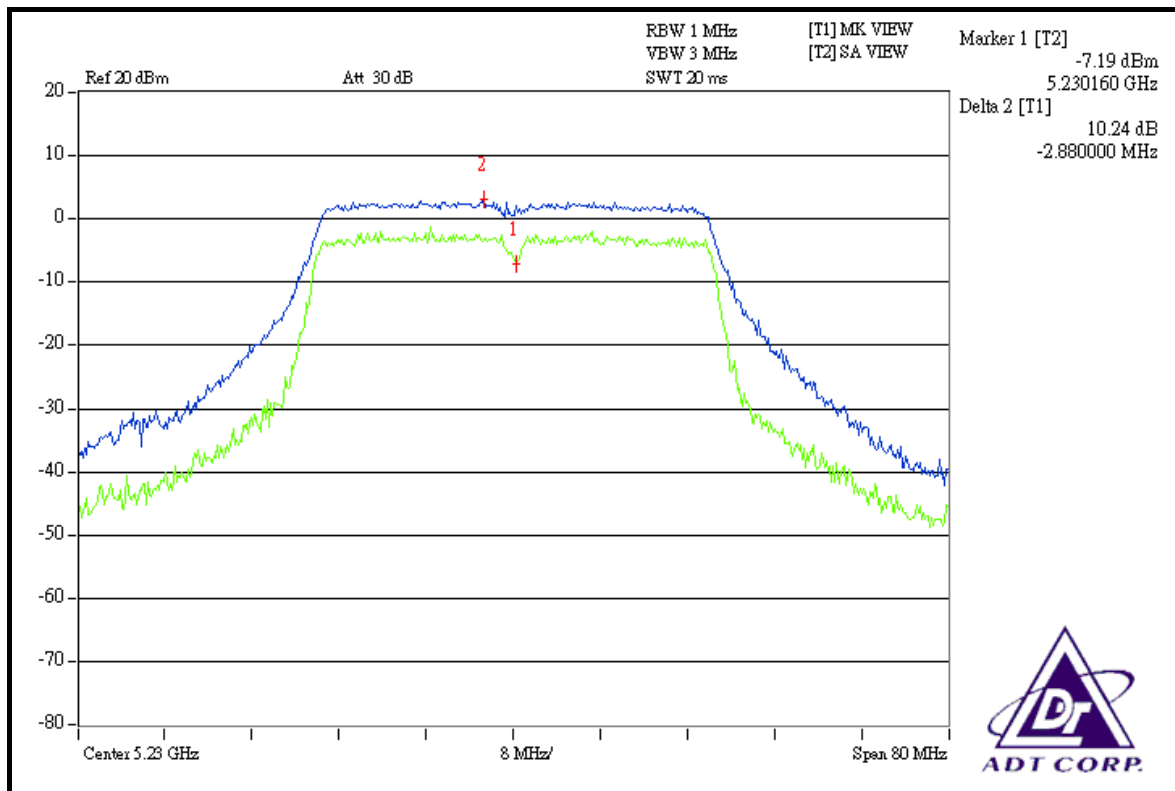





### FOR CHAIN 1: CH 38

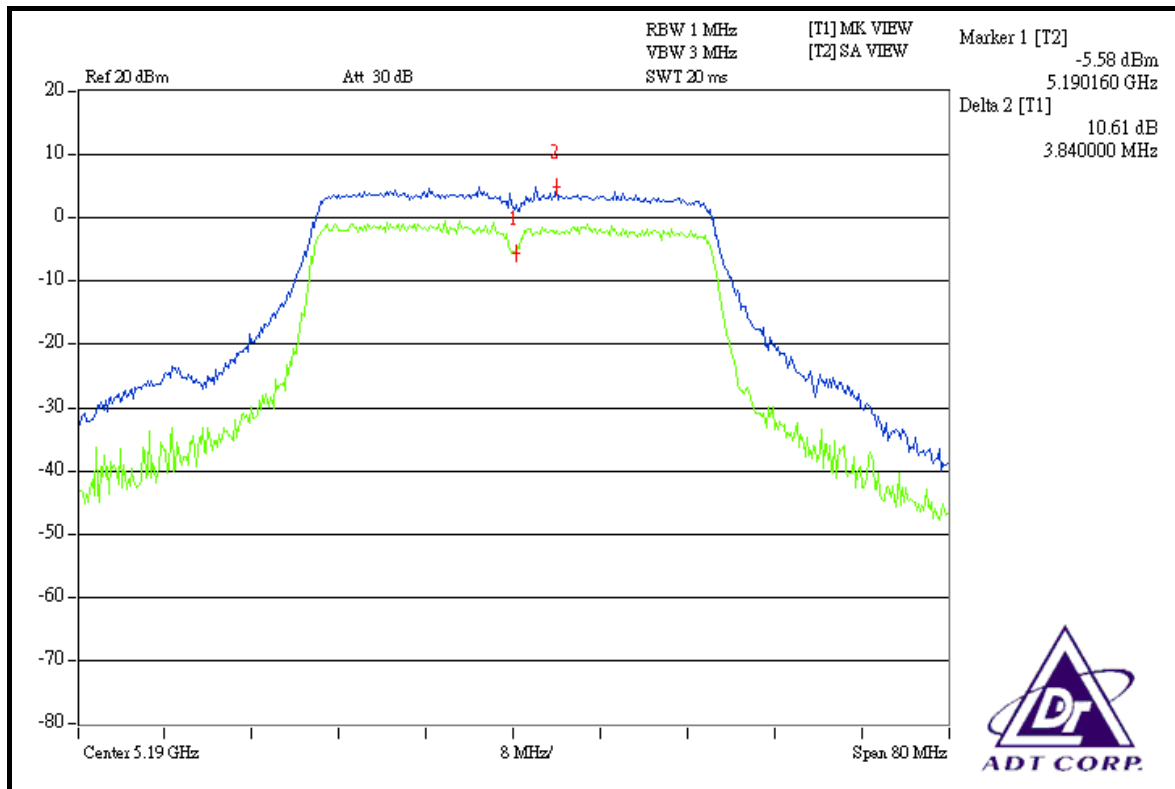

### CH 46

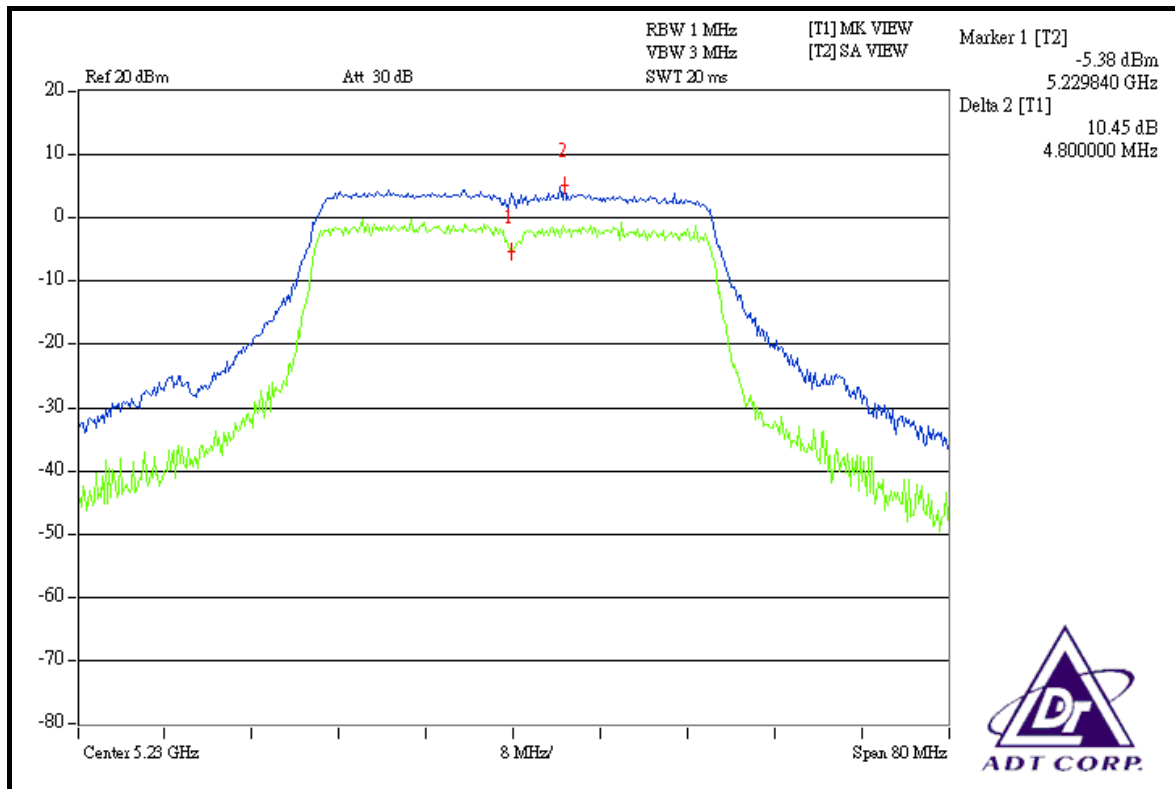



### FOR CHAIN 2: CH 38

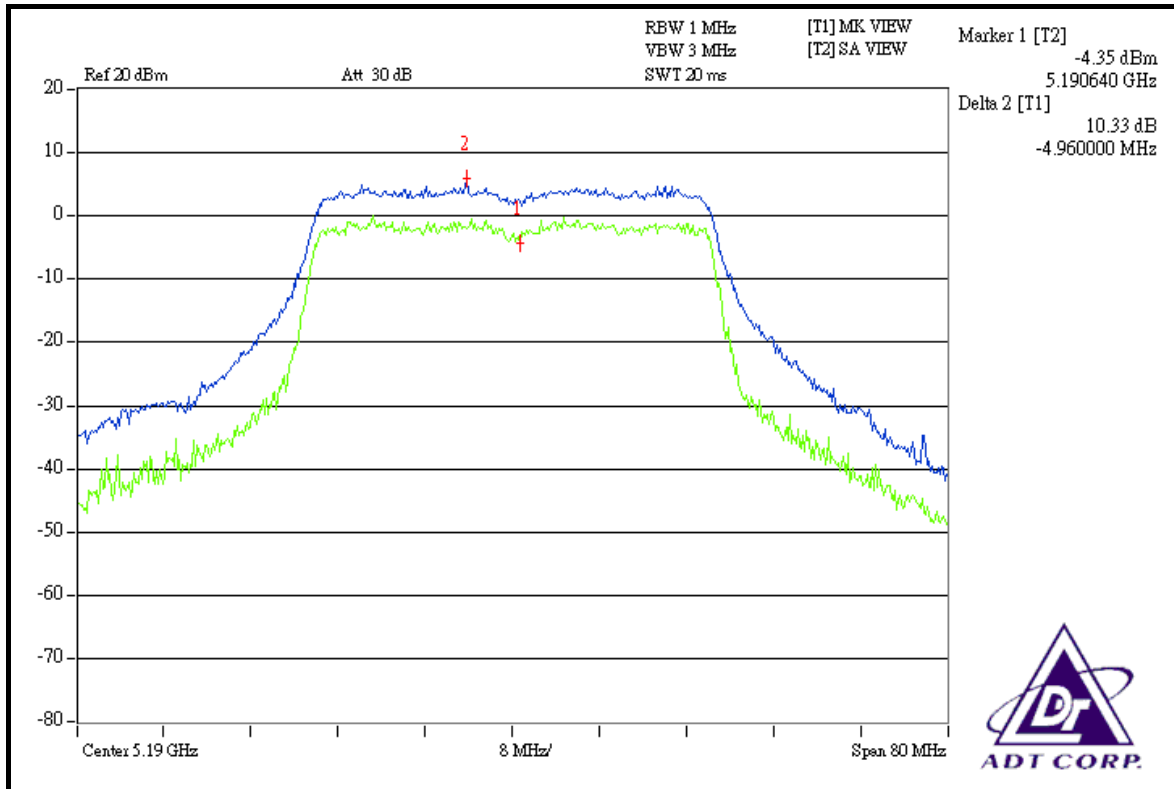

### CH 46

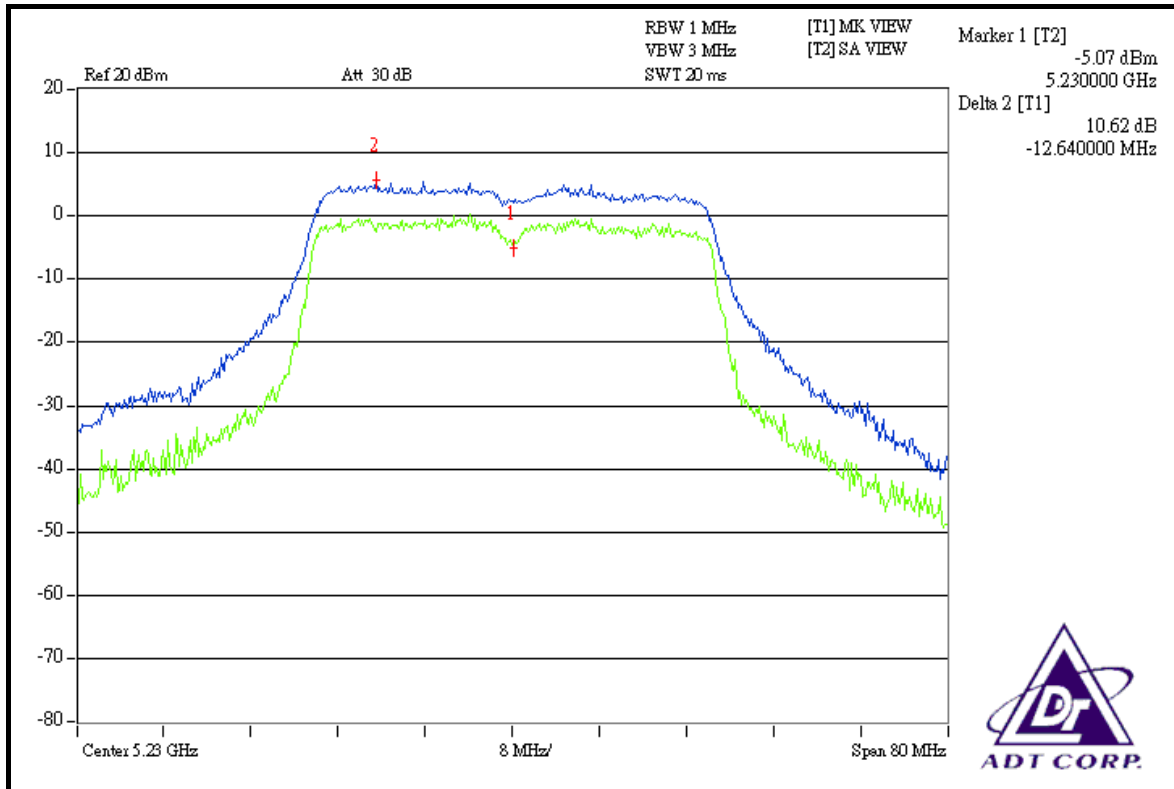



## 4.5 PEAK POWER SPECTRAL DENSITY MEASUREMENT

### 4.5.1 LIMITS OF PEAK POWER SPECTRAL DENSITY MEASUREMENT

| FREQUENCY BAND | LIMIT |
|----------------|-------|
| 5.15 ~ 5.25GHz | 4dBm  |

### 4.5.2 TEST INSTRUMENTS

| DESCRIPTION & MANUFACTURER | MODEL NO. | SERIAL NO. | CALIBRATED UNTIL |
|----------------------------|-----------|------------|------------------|
| R&S SPECTRUM ANALYZER      | FSP40     | 100040     | Jun. 28, 2008    |

**NOTE:** The calibration interval of the above test instruments is 12 months and the calibrations are traceable to NML/ROC and NIST/USA.

### 4.5.3 TEST PROCEDURES

- a. The transmitter output was connected to the spectrum analyzer.
- b. Set RBW = 1MHz, VBW = 3MHz. The PPSD is the highest level found across the emission in any 1MHz band.

#### 4.5.4 DEVIATION FROM TEST STANDARD

No deviation

#### 4.5.5 TEST SETUP

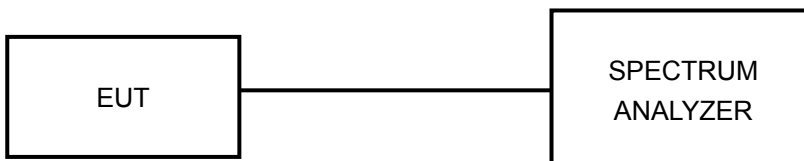

#### 4.5.6 EUT OPERATING CONDITIONS

Same as 5.3.6

## 4.5.7 TEST RESULTS

### 802.11a OFDM MODULATION

|                             |              |                                 |                          |
|-----------------------------|--------------|---------------------------------|--------------------------|
| <b>MODULATION TYPE</b>      | BPSK         | <b>TRANSFER RATE</b>            | 6.0Mbps                  |
| <b>INPUT POWER (SYSTEM)</b> | 120Vac, 60Hz | <b>ENVIRONMENTAL CONDITIONS</b> | 26 deg.C, 67 %RH, 991hPa |
| <b>TESTED BY</b>            | Dean Wang    |                                 |                          |

| CHANNEL | CHANNEL FREQUENCY (MHz) | RF POWER LEVEL IN 1MHz BW (dBm) | MAXIMUM LIMIT (dBm) | PASS / FAIL |
|---------|-------------------------|---------------------------------|---------------------|-------------|
| 36      | 5180                    | 0.70                            | 4                   | PASS        |
| 40      | 5200                    | 0.64                            | 4                   | PASS        |
| 48      | 5240                    | 0.65                            | 4                   | PASS        |

### CH 36

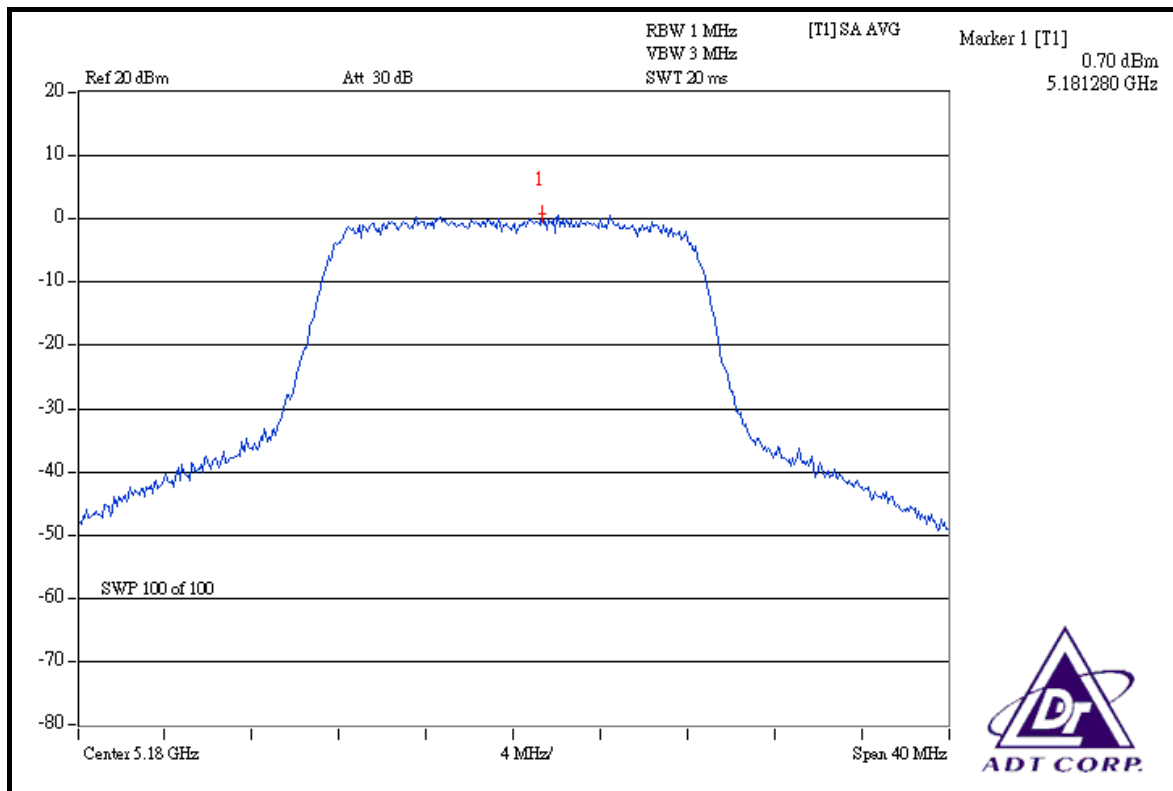



### CH 40

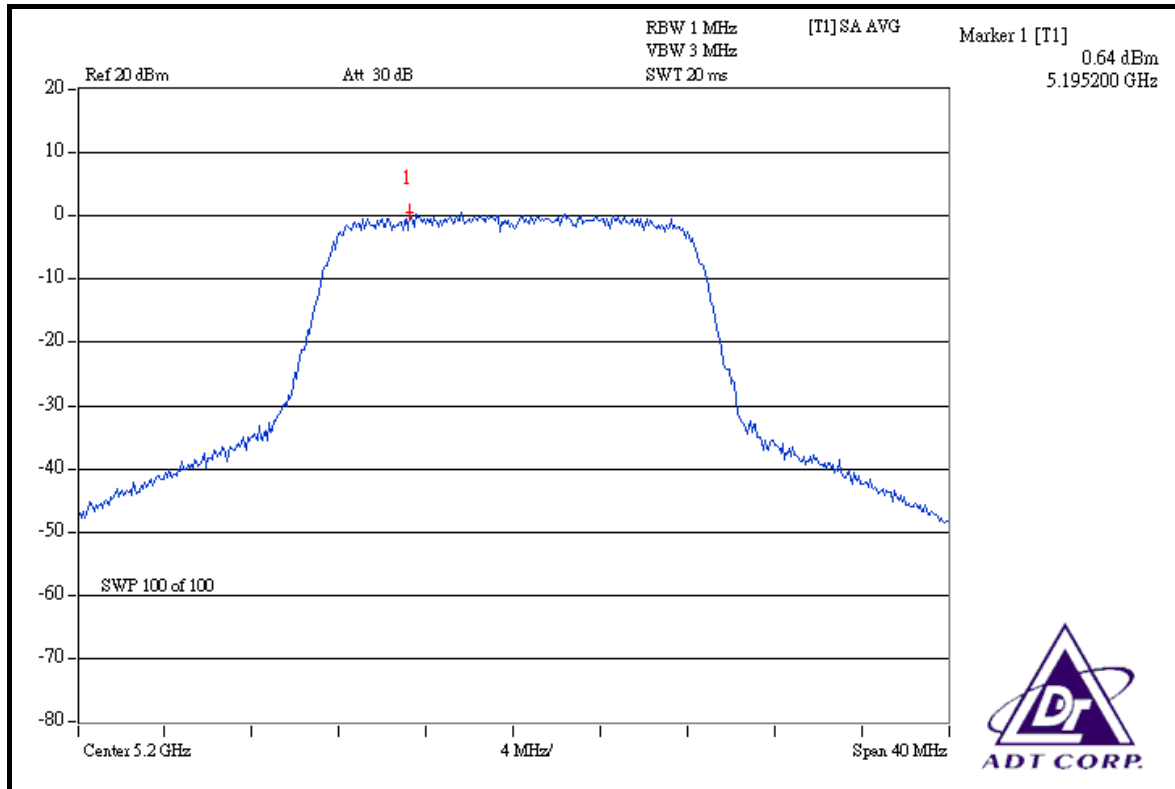

### CH 48

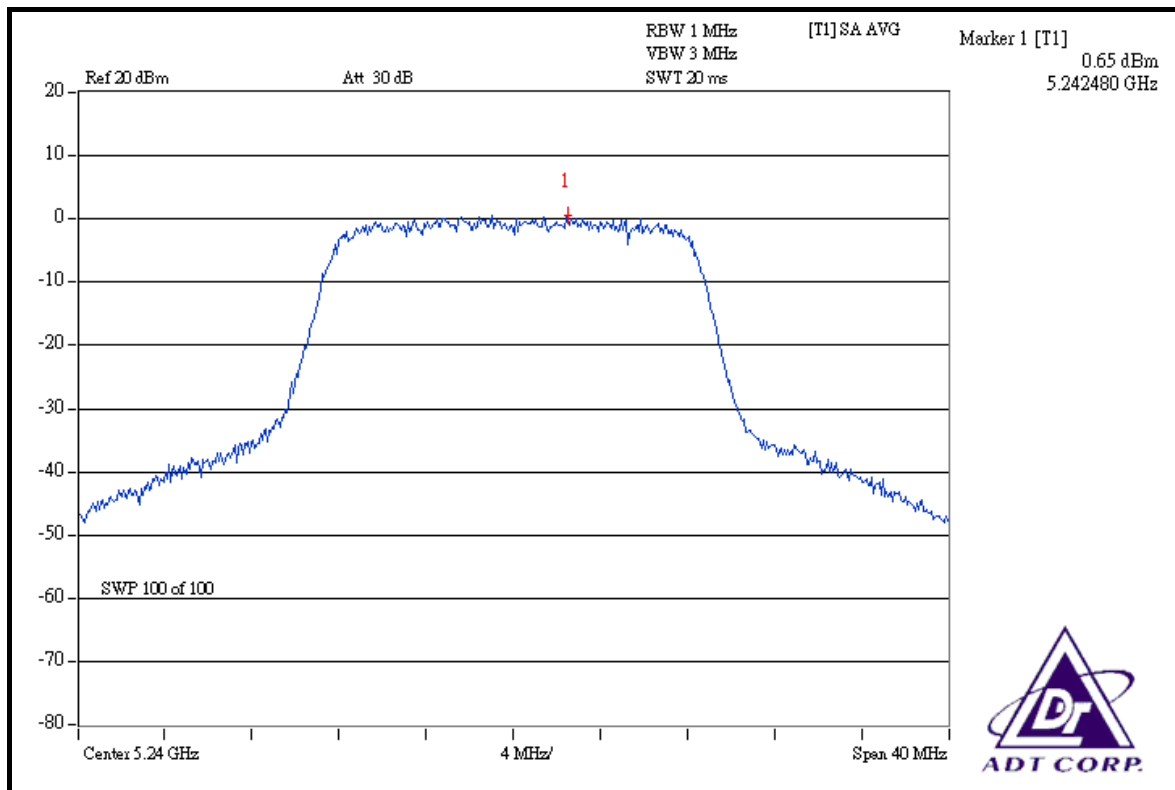



**DRAFT 802.11n (20MHz) OFDM MODULATION**

|                             |              |                                 |                          |
|-----------------------------|--------------|---------------------------------|--------------------------|
| <b>MODULATION TYPE</b>      | BPSK         | <b>TRANSFER RATE</b>            | 7.2Mbps                  |
| <b>INPUT POWER (SYSTEM)</b> | 120Vac, 60Hz | <b>ENVIRONMENTAL CONDITIONS</b> | 26 deg.C, 67 %RH, 991hPa |
| <b>TESTED BY</b>            | Dean Wang    |                                 |                          |

| CHAN. | CHAN. FREQ. (MHz) | RF POWER LEVEL IN 3kHz BW (dBm) |         |         | TOTAL POWER DENSITY (mW) | TOTAL POWER DENSITY (dBm) | MAX. LIMIT (dBm) | PASS / FAIL |
|-------|-------------------|---------------------------------|---------|---------|--------------------------|---------------------------|------------------|-------------|
|       |                   | CHAIN 0                         | CHAIN 1 | CHAIN 2 |                          |                           |                  |             |
| 36    | 5180              | -5.19                           | -4.43   | -4.71   | 1.001                    | 0.01                      | 4                | PASS        |
| 40    | 5200              | -5.60                           | -4.65   | -4.91   | 0.941                    | -0.26                     | 4                | PASS        |
| 48    | 5240              | -5.20                           | -4.04   | -4.76   | 1.031                    | 0.13                      | 4                | PASS        |

**FOR CHAIN 0: CH 36**

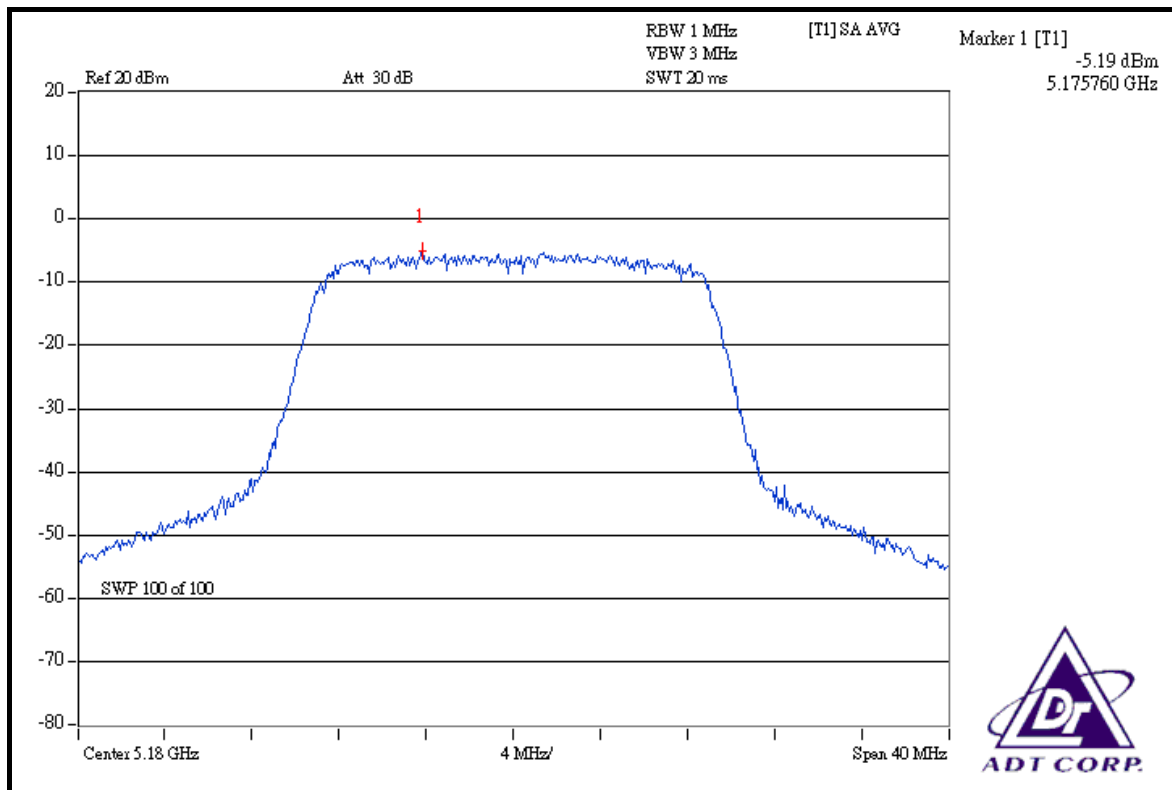



### CH 40

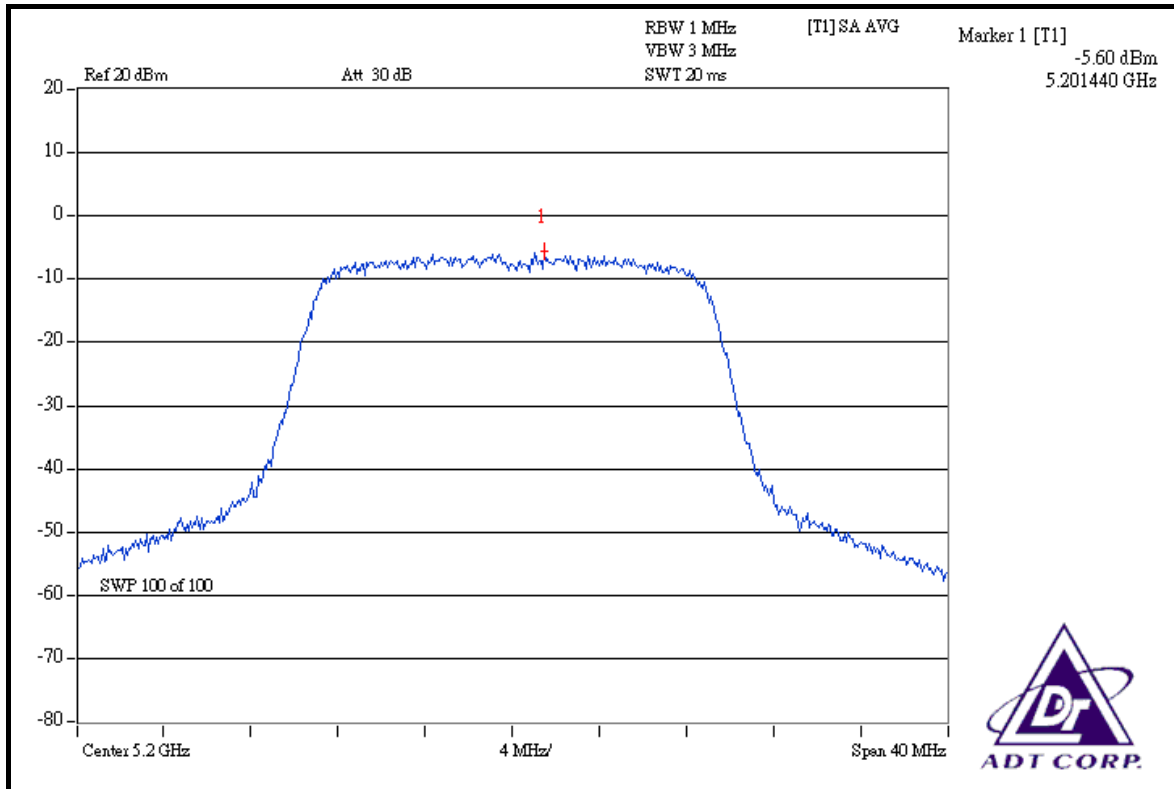

### CH 48

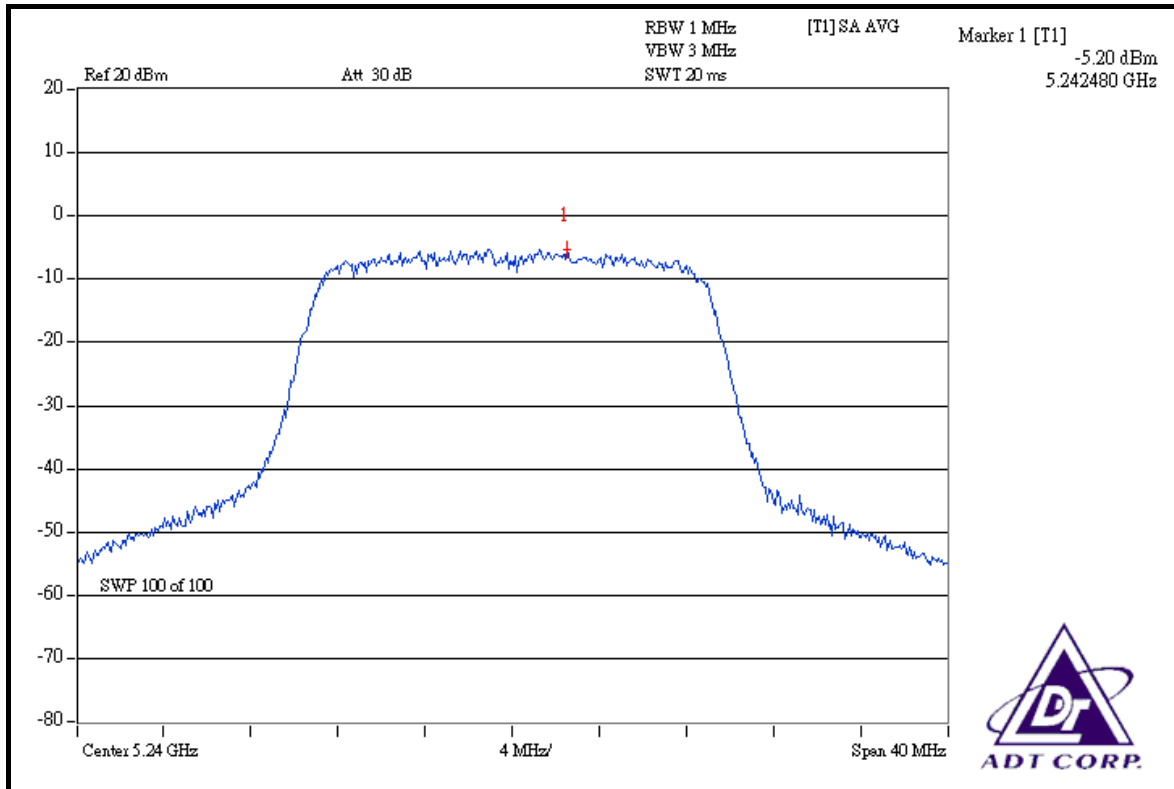





### FOR CHAIN 1: CH 36

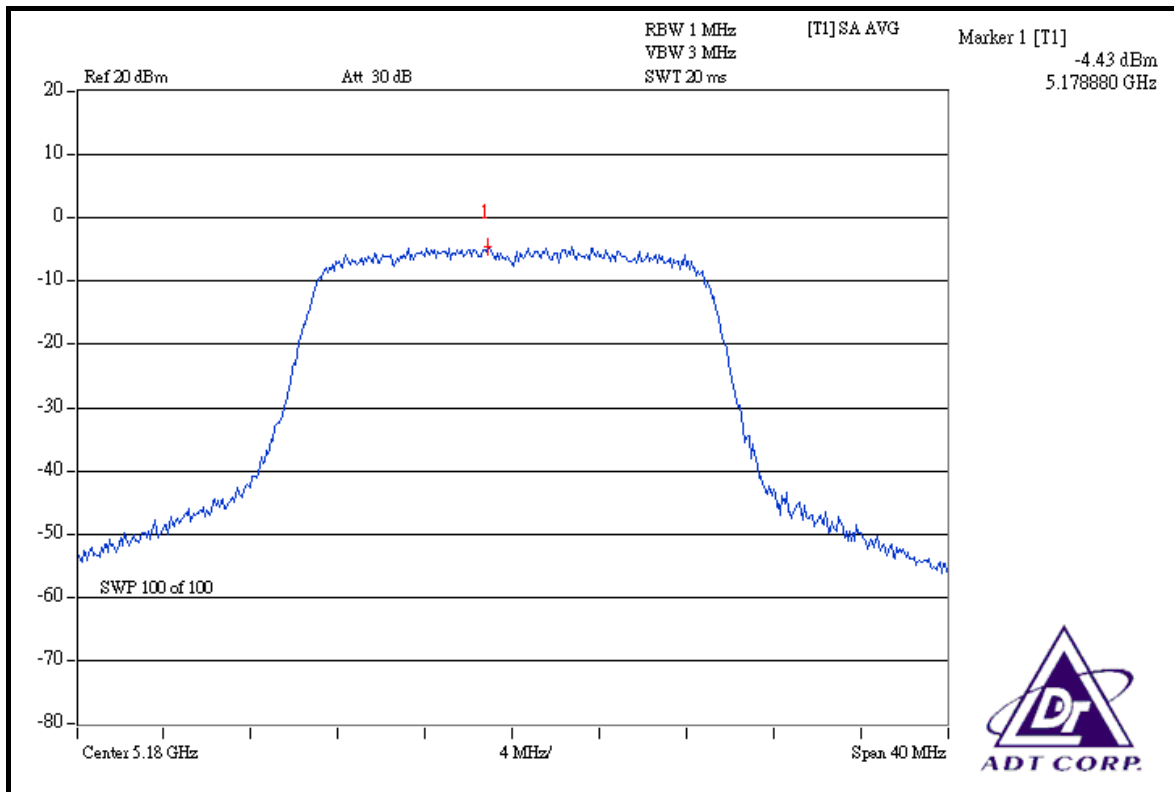

### CH 40

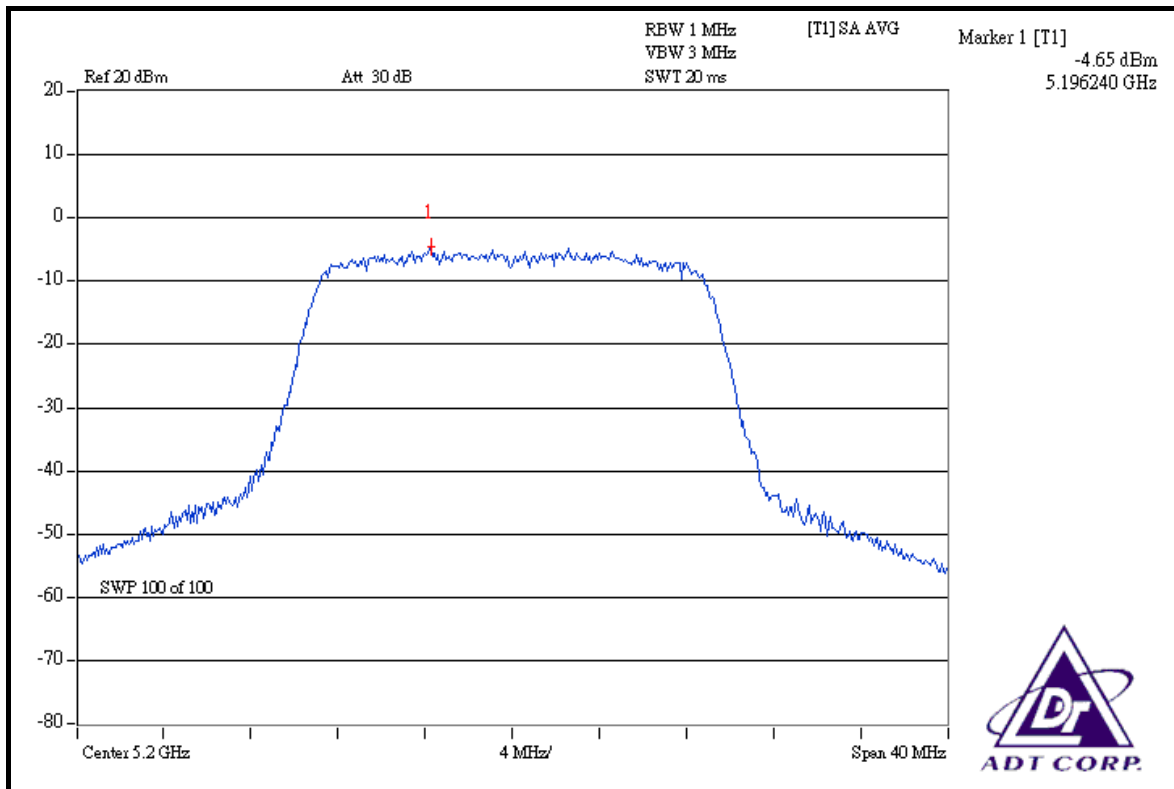



### CH 48

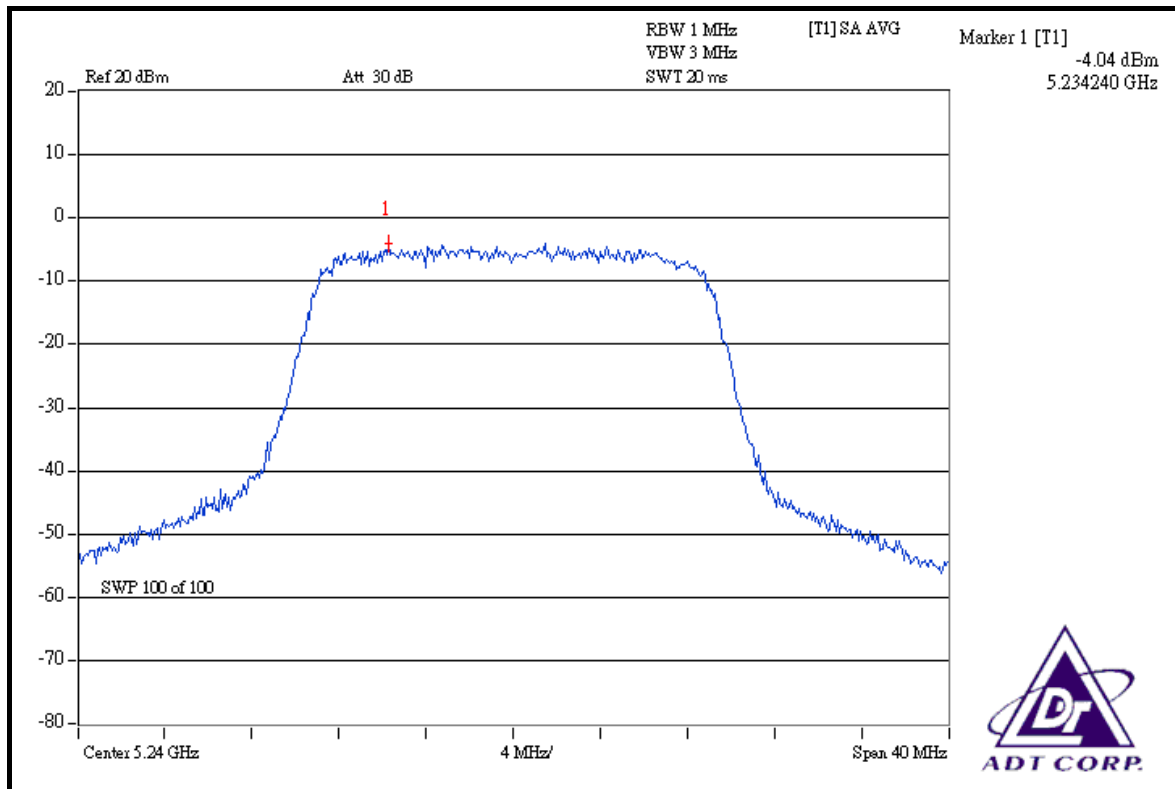

### FOR CHAIN 2: CH 36

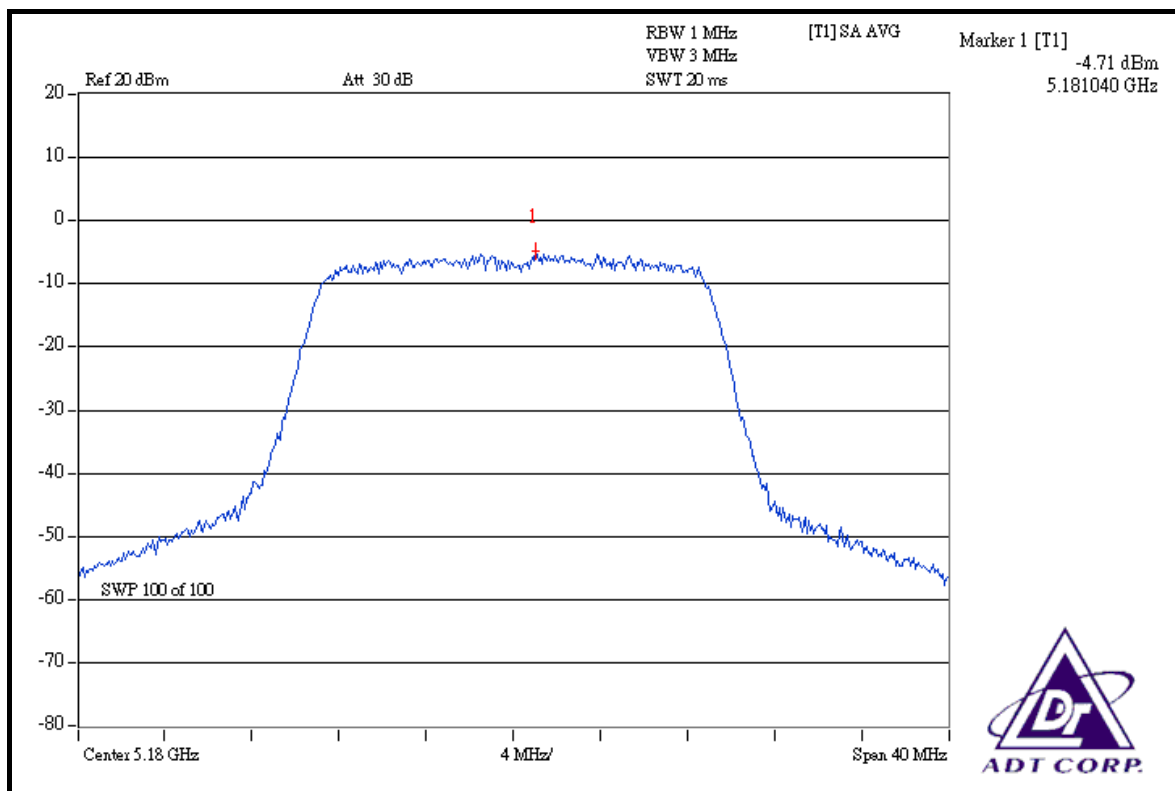



### CH 40

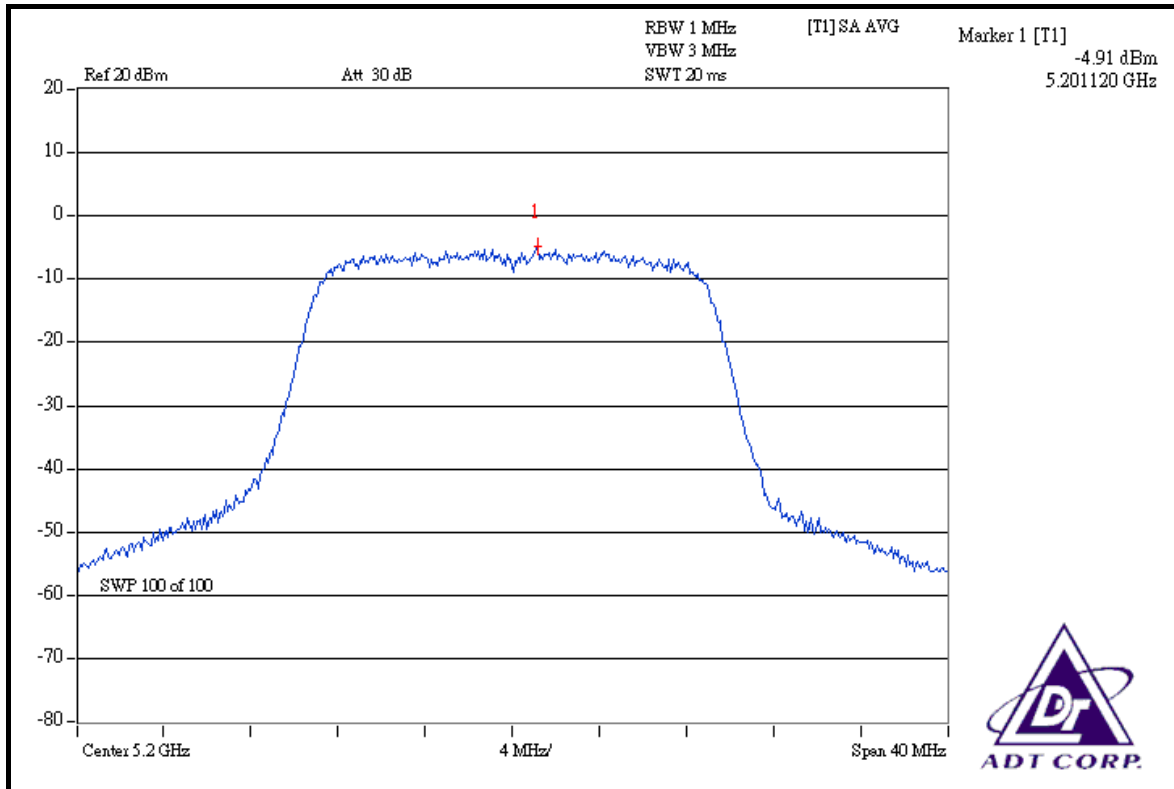

### CH 48

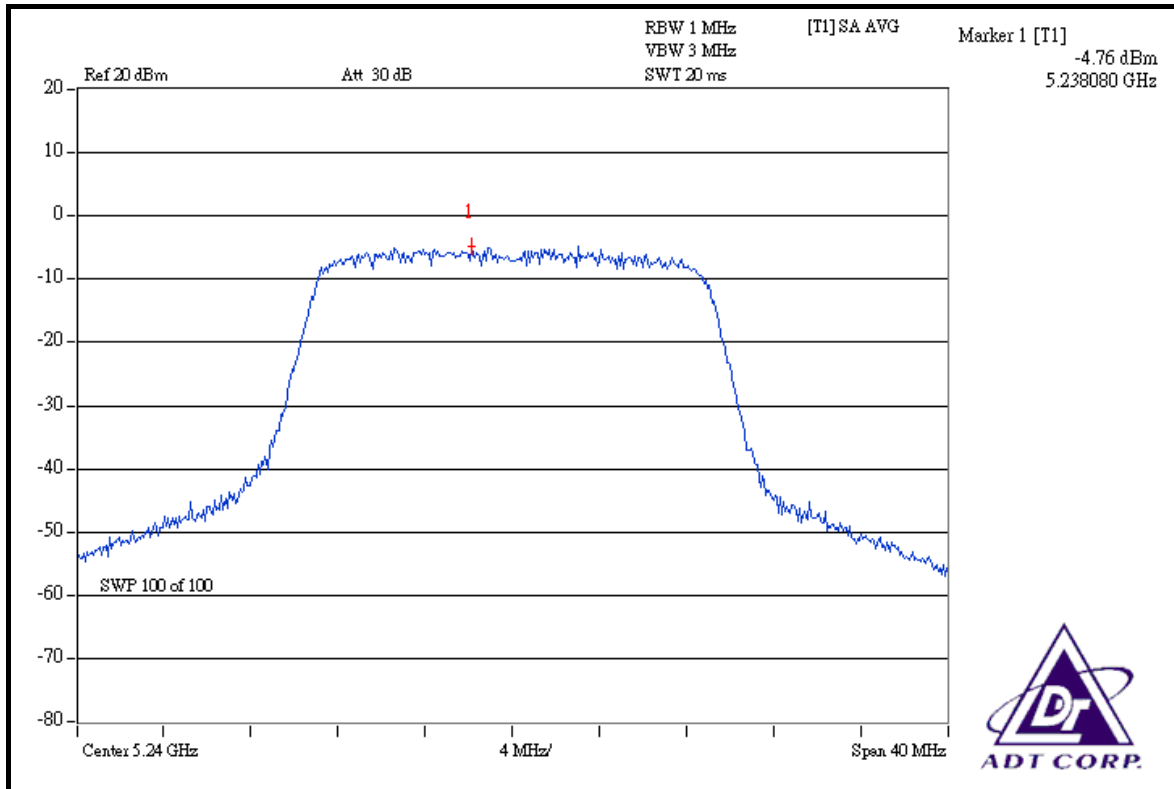



**DRAFT 802.11n (40MHz) OFDM MODULATION**

|                             |              |                                 |                          |
|-----------------------------|--------------|---------------------------------|--------------------------|
| <b>MODULATION TYPE</b>      | BPSK         | <b>TRANSFER RATE</b>            | 15Mbps                   |
| <b>INPUT POWER (SYSTEM)</b> | 120Vac, 60Hz | <b>ENVIRONMENTAL CONDITIONS</b> | 26 deg.C, 67 %RH, 991hPa |
| <b>TESTED BY</b>            | Dean Wang    |                                 |                          |

| CHAN. | CHAN. FREQ. (MHz) | RF POWER LEVEL IN 3kHz BW (dBm) |         |         | TOTAL POWER DENSITY (mW) | TOTAL POWER DENSITY (dBm) | MAX. LIMIT (dBm) | PASS / FAIL |
|-------|-------------------|---------------------------------|---------|---------|--------------------------|---------------------------|------------------|-------------|
|       |                   | CHAIN 0                         | CHAIN 1 | CHAIN 2 |                          |                           |                  |             |
| 38    | 5190              | -8.58                           | -7.02   | -7.27   | 0.525                    | -2.80                     | 4                | PASS        |
| 46    | 5230              | -7.95                           | -6.84   | -7.03   | 0.566                    | -2.48                     | 4                | PASS        |



FOR CHAIN 0: CH 38

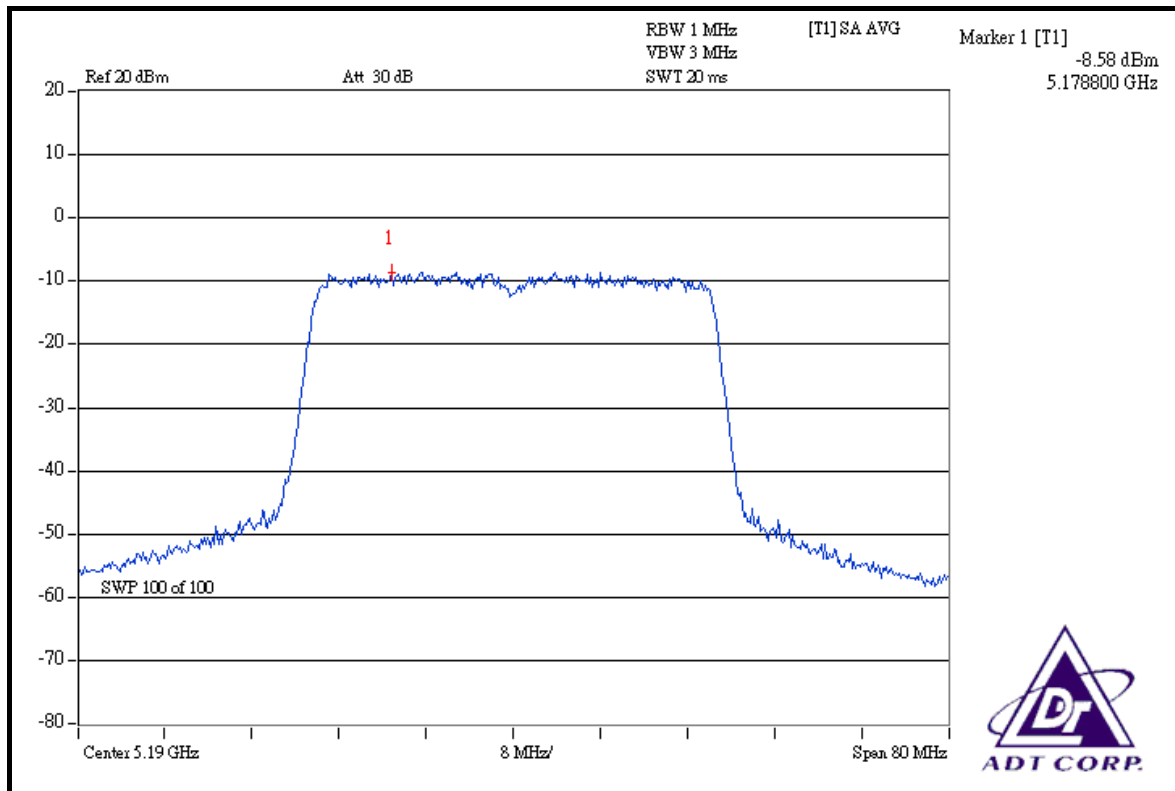

CH 46

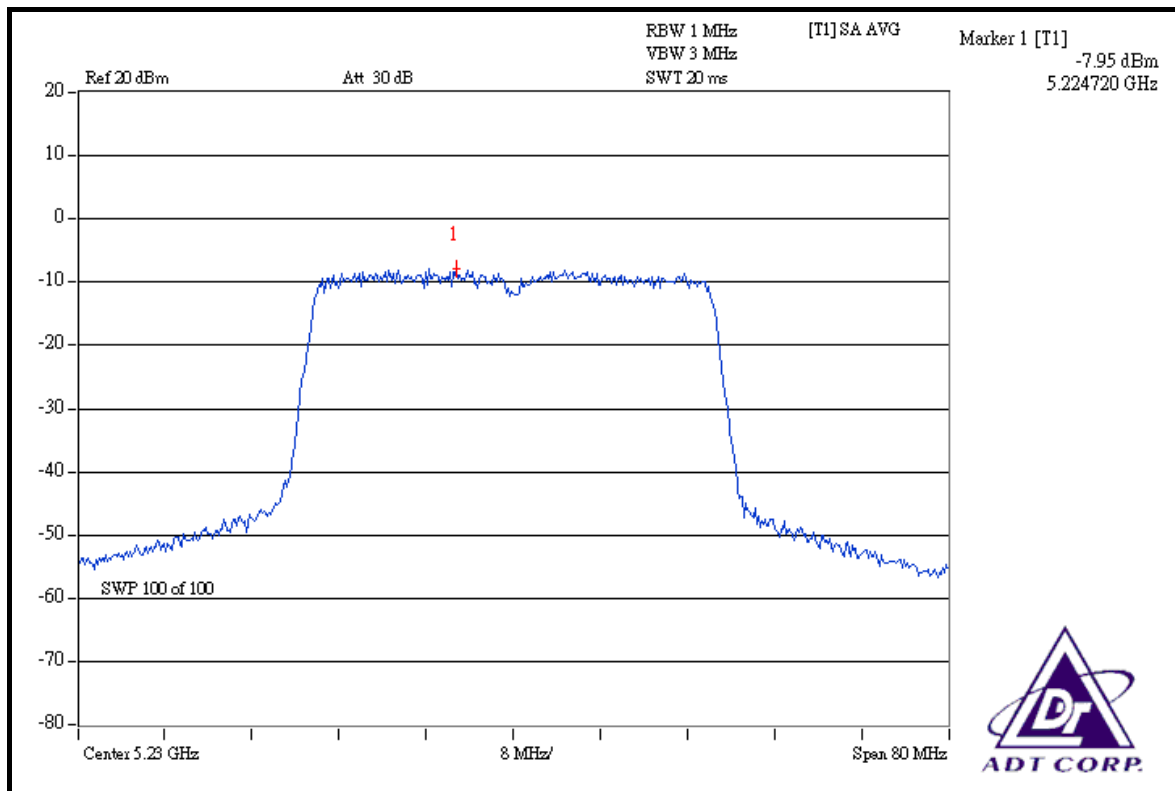



### FOR CHAIN 1: CH 38

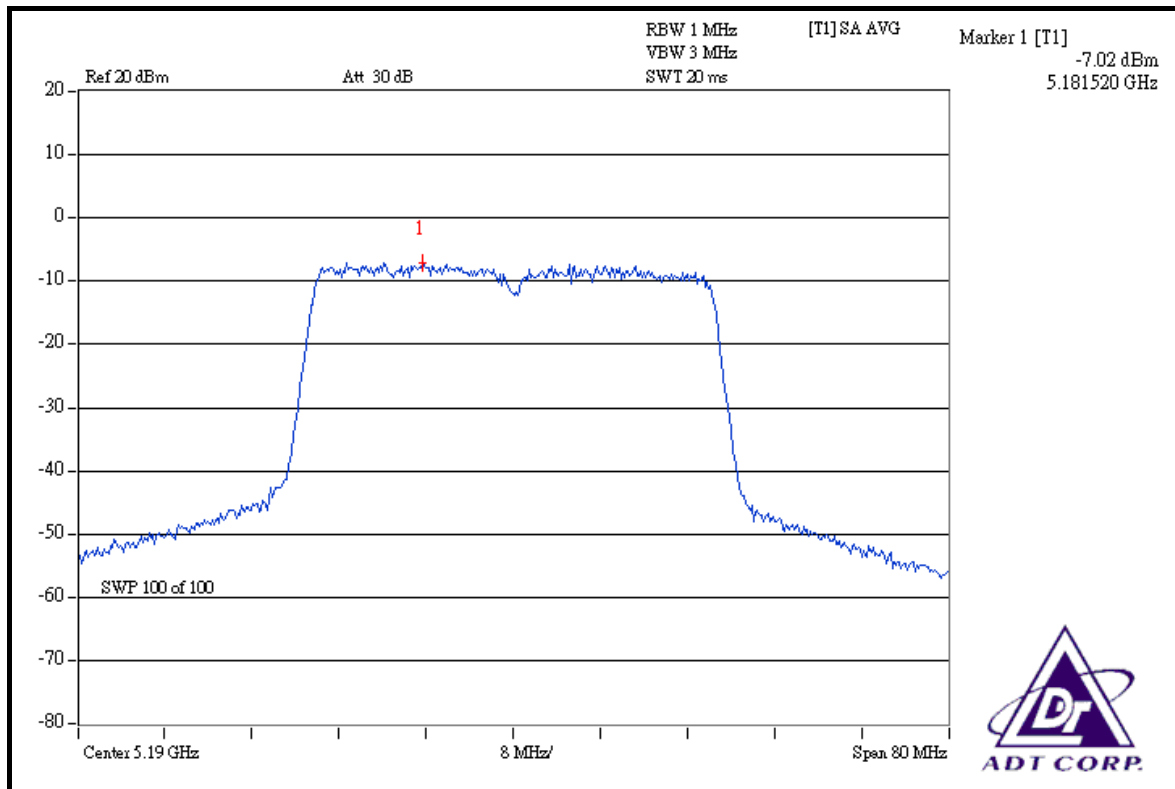

### CH 46

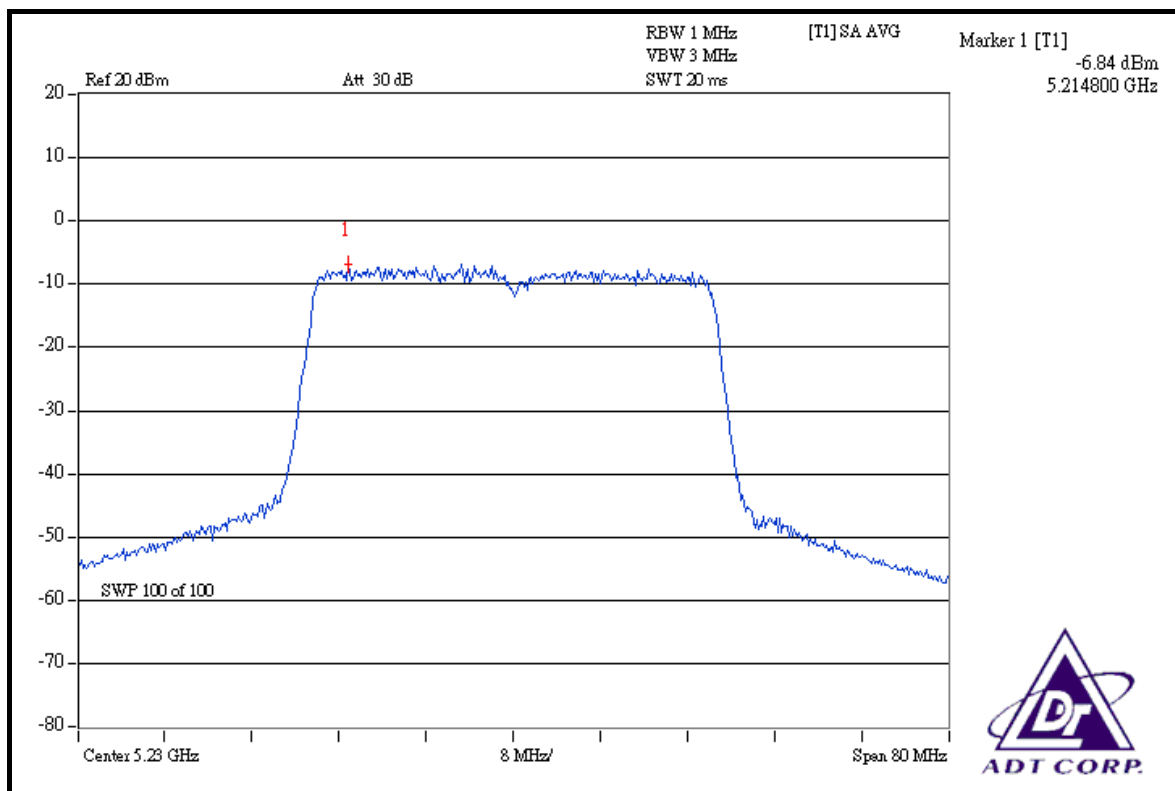



### FOR CHAIN 2: CH 38

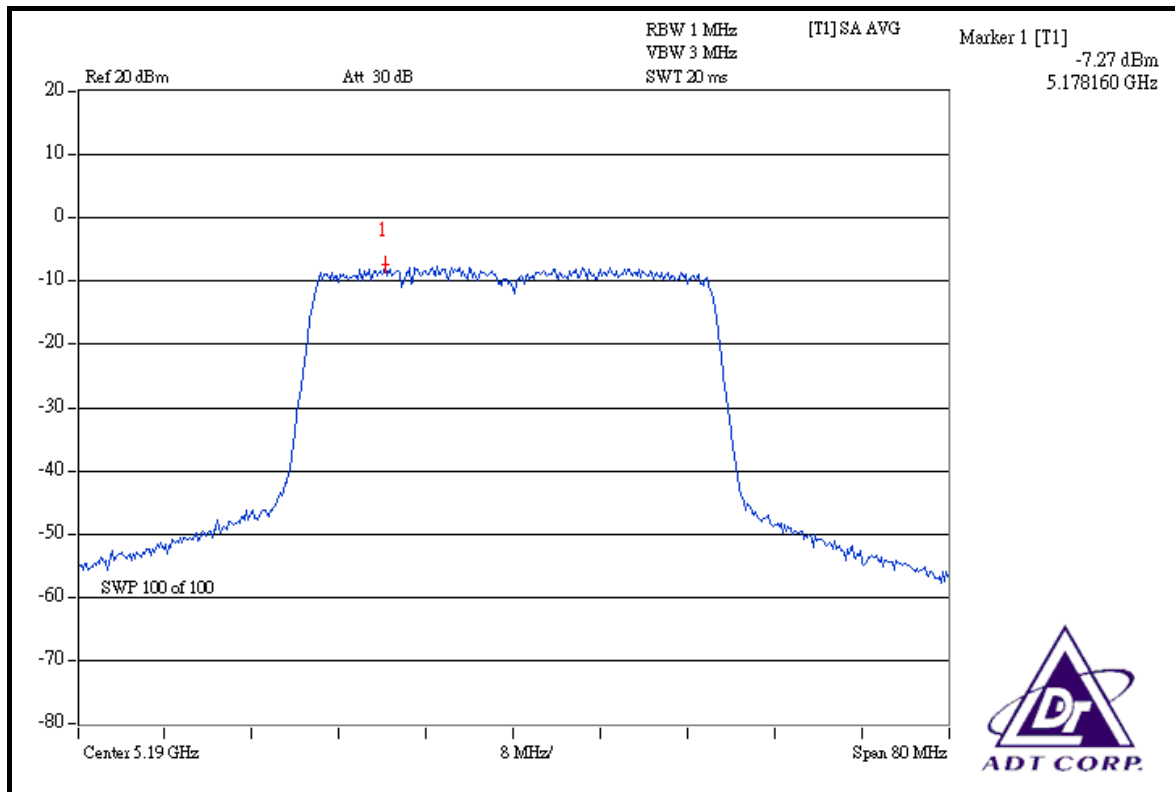

### CH 46

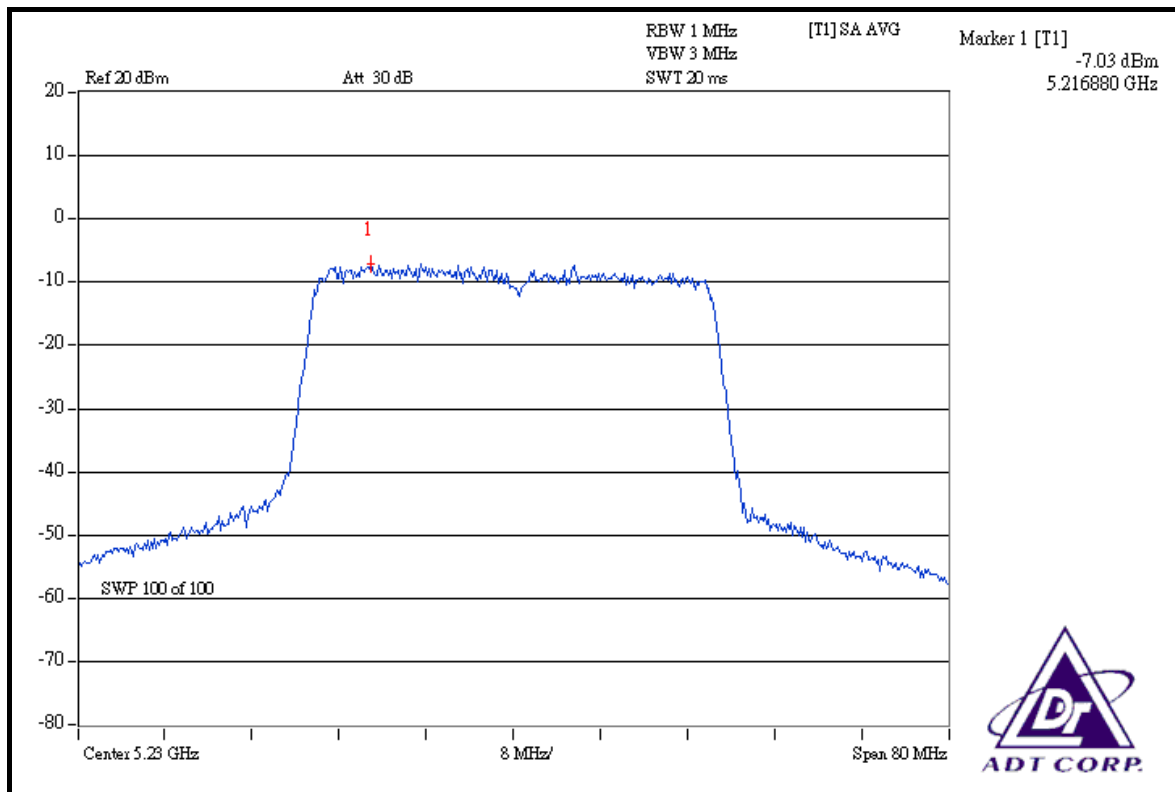



## 4.6 FREQUENCY STABILITY

### 4.6.1 LIMITS OF FREQUENCY STABILITY MEASUREMENT

The frequency tolerance of the carrier signal shall be maintained within +/- 0.02% of the operating frequency over a temperature variation of -30 degrees to 50 degrees C at normal supply voltage, and for a variation in the primary supply voltage from 85% to 115% of the rated supply voltage at a temperature of 20 degrees C.

### 4.6.2 TEST INSTRUMENTS

| DESCRIPTION & MANUFACTURER                    | MODEL NO. | SERIAL NO. | CALIBRATED UNTIL |
|---|-----------|------------|------------------|
| ANRITSU SPECTRUM ANALYZER                     | MS2667C   | M10281     | Nov. 21, 2008    |
| WIT STANDARD TEMPERATURE AND HUMIDITY CHAMBER | TH-4S-C   | W981030    | Jun. 28, 2008    |

**NOTE:** The calibration interval of the above test instruments is 12 months and the calibrations are traceable to NML/ROC and NIST/USA.

### 4.6.3 TEST PROCEDURE

- a. The EUT was placed inside the environmental test chamber and powered by nominal DC voltage.
- b. Turn the EUT on and couple its output to a spectrum analyzer.
- c. Turn the EUT off and set the chamber to the highest temperature specified.
- d. Allow sufficient time (approximately 30 min) for the temperature of the chamber to stabilize, turn the EUT on and measure the operating frequency after 2, 5, and 10 minutes.
- e. Repeat step 2 and 3 with the temperature chamber set to the lowest temperature.
- f. The test chamber was allowed to stabilize at +20 degree C for a minimum of 30 minutes. The supply voltage was then adjusted on the EUT from 85% to 115% and the frequency record.



#### 4.6.4 DEVIATION FROM TEST STANDARD

No deviation

#### 4.6.5 TEST SETUP

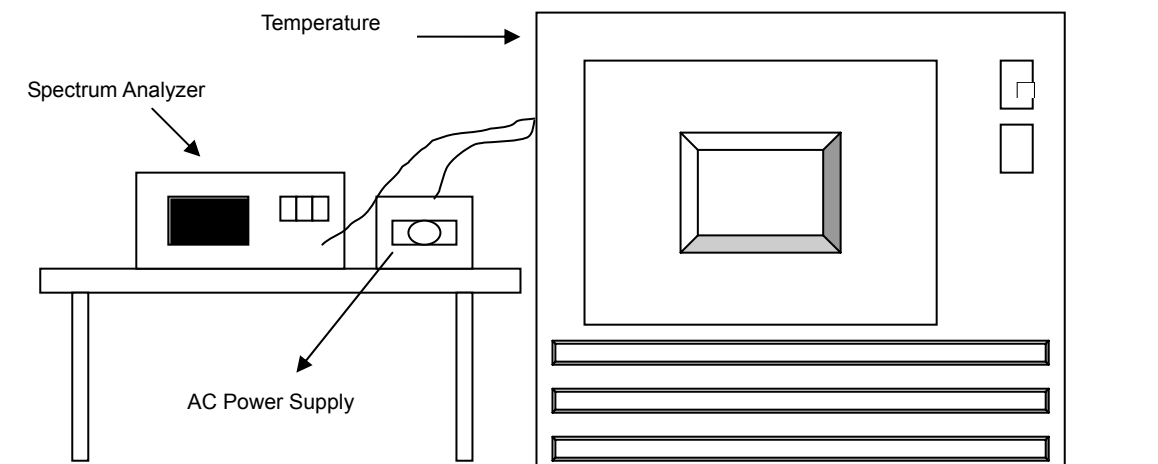

#### 4.6.6 EUT OPERATING CONDITION

Same as Item 4.1.6



#### 4.6.7 TEST RESULTS

| OPERATING FREQUENCY: 5200MHz |                          |             |           |             |           | LIMIT: ± 0.01% |           |             |           |
|------------------------------|--------------------------|-------------|-----------|-------------|-----------|----------------|-----------|-------------|-----------|
| TEMP.<br>(°C)                | POWER<br>SUPPLY<br>(Vac) | 0 MINUTE    |           | 2 MINUTE    |           | 5 MINUTE       |           | 10 MINUTE   |           |
|                              |                          | (MHz)       | (%)       | (MHz)       | (%)       | (MHz)          | (%)       | (MHz)       | (%)       |
| 50                           | 126.5                    | 5200.026759 | 0.0005146 | 5200.017812 | 0.0003425 | 5200.032066    | 0.0006167 | 5200.040985 | 0.0007882 |
|                              | 110.0                    | 5200.025093 | 0.0004826 | 5200.023827 | 0.0004582 | 5200.013536    | 0.0002603 | 5200.024507 | 0.0004713 |
|                              | 93.5                     | 5200.026649 | 0.0005125 | 5200.026164 | 0.0005032 | 5200.017311    | 0.0003329 | 5200.027546 | 0.0005297 |
| 40                           | 126.5                    | 5200.018989 | 0.0003652 | 5200.020330 | 0.0003910 | 5200.009531    | 0.0001833 | 5200.020685 | 0.0003978 |
|                              | 110.0                    | 5200.024726 | 0.0004755 | 5200.026223 | 0.0005043 | 5200.014895    | 0.0002864 | 5200.024750 | 0.0004760 |
|                              | 93.5                     | 5200.035672 | 0.0006860 | 5200.038185 | 0.0007343 | 5200.026678    | 0.0005130 | 5200.038088 | 0.0007325 |
| 30                           | 126.5                    | 5200.019515 | 0.0003753 | 5200.020482 | 0.0003939 | 5200.009270    | 0.0001783 | 5200.020886 | 0.0004017 |
|                              | 110.0                    | 5200.026710 | 0.0005137 | 5200.025598 | 0.0004923 | 5200.016639    | 0.0003200 | 5200.027008 | 0.0005194 |
|                              | 93.5                     | 5200.044598 | 0.0008576 | 5200.043286 | 0.0008324 | 5200.035584    | 0.0006843 | 5200.046450 | 0.0008933 |
| 20                           | 126.5                    | 5200.027769 | 0.0005340 | 5200.027130 | 0.0005217 | 5200.017978    | 0.0003457 | 5200.026799 | 0.0005154 |
|                              | 110.0                    | 5200.028967 | 0.0005571 | 5200.026931 | 0.0005179 | 5200.018420    | 0.0003542 | 5200.028060 | 0.0005396 |
|                              | 93.5                     | 5200.053175 | 0.0010226 | 5200.052809 | 0.0010156 | 5200.041874    | 0.0008053 | 5200.051514 | 0.0009907 |
| 10                           | 126.5                    | 5200.034732 | 0.0006679 | 5200.033403 | 0.0006424 | 5200.025607    | 0.0004924 | 5200.035475 | 0.0006822 |
|                              | 110.0                    | 5200.041937 | 0.0008065 | 5200.043298 | 0.0008327 | 5200.032430    | 0.0006237 | 5200.044199 | 0.0008500 |
|                              | 93.5                     | 5200.059190 | 0.0011383 | 5200.059869 | 0.0011513 | 5200.049341    | 0.0009489 | 5200.058053 | 0.0011164 |
| 0                            | 126.5                    | 5200.037906 | 0.0007290 | 5200.038600 | 0.0007423 | 5200.028078    | 0.0005400 | 5200.038299 | 0.0007365 |
|                              | 110.0                    | 5200.049643 | 0.0009547 | 5200.050384 | 0.0009689 | 5200.041853    | 0.0008049 | 5200.051099 | 0.0009827 |
|                              | 93.5                     | 5200.064880 | 0.0012477 | 5200.064067 | 0.0012321 | 5200.052858    | 0.0010165 | 5200.065346 | 0.0012567 |
| -10                          | 126.5                    | 5200.049892 | 0.0009595 | 5200.050054 | 0.0009626 | 5200.040942    | 0.0007873 | 5200.050470 | 0.0009706 |
|                              | 110.0                    | 5200.056917 | 0.0010946 | 5200.057075 | 0.0010976 | 5200.046698    | 0.0008980 | 5200.056942 | 0.0010950 |
|                              | 93.5                     | 5200.072078 | 0.0013861 | 5200.070128 | 0.0013486 | 5200.062304    | 0.0011982 | 5200.072470 | 0.0013937 |
| -20                          | 126.5                    | 5200.056054 | 0.0010780 | 5200.055123 | 0.0010601 | 5200.046425    | 0.0008928 | 5200.055706 | 0.0010713 |
|                              | 110.0                    | 5200.061196 | 0.0011769 | 5200.060087 | 0.0011555 | 5200.051647    | 0.0009932 | 5200.059751 | 0.0011491 |
|                              | 93.5                     | 5200.077074 | 0.0014822 | 5200.076968 | 0.0014802 | 5200.065203    | 0.0012539 | 5200.075408 | 0.0014502 |
| -30                          | 126.5                    | 5200.059602 | 0.0011462 | 5200.060576 | 0.0011649 | 5200.052251    | 0.0010048 | 5200.062664 | 0.0012051 |
|                              | 110.0                    | 5200.073624 | 0.0014158 | 5200.075511 | 0.0014521 | 5200.066162    | 0.0012723 | 5200.075227 | 0.0014467 |
|                              | 93.5                     | 5200.077075 | 0.0014822 | 5200.077496 | 0.0014903 | 5200.069763    | 0.0013416 | 5200.078519 | 0.0015100 |



## 4.7 BAND EDGES MEASUREMENT

### 4.7.1 TEST INSTRUMENTS

| DESCRIPTION & MANUFACTURER                    | MODEL NO.         | SERIAL NO.     | CALIBRATED UNTIL |
|---|-------------------|----------------|------------------|
| <b>FOR CONDUCTED MEASUREMENT:</b>             |                   |                |                  |
| R&S SPECTRUM ANALYZER                         | FSP40             | 100040         | Jun. 28, 2008    |
| <b>FOR RADIATED MEASUREMENT:</b>              |                   |                |                  |
| Test Receiver<br>ROHDE & SCHWARZ              | ESIB7             | 100212         | May. 27, 2009    |
| Spectrum Analyzer<br>ROHDE & SCHWARZ          | FSP40             | 100269         | Aug. 05, 2008    |
| BILOG Antenna<br>SCHWARZBECK                  | VULB9168          | 9168-153       | Jan. 03, 2009    |
| HORN Antenna<br>SCHWARZBECK                   | BBHA 9120 D       | 9120D-563      | Jul. 30, 2008    |
| HORN Antenna<br>SCHWARZBECK                   | BBHA 9170         | BBHA9170242    | Jan. 06, 2009    |
| Preamplifier<br>Agilent                       | 8449B             | 3008A01910     | Sep. 19, 2008    |
| Preamplifier<br>Agilent                       | 8447D             | 2944A10638     | Dec. 19, 2008    |
| RF signal cable<br>HUBER+SUHNNER              | SUCOFLEX 104      | 274039/223650  | Nov. 07, 2008    |
| RF signal cable<br>Worken                     | 8D-FB             | Cable-HYCH9-01 | Aug. 09, 2008    |
| Software                                      | ADT_Radiated_V7.6 | NA             | NA               |
| Antenna Tower<br>EMCO                         | 2070/2080         | 512.835.4684   | NA               |
| Turn Table<br>EMCO                            | 2087-2.03         | NA             | NA               |
| Antenna Tower & Turn Table<br>Controller EMCO | 2090              | NA             | NA               |
| 26GHz ~ 40GHz Amplifier                       | EM26400           | 07026401       | May 05, 2009     |

**NOTE:** The calibration interval of the above test instruments is 12 months and the calibrations are traceable to NML/ROC and NIST/USA.

#### 4.7.2 TEST PROCEDURE

##### FOR CONDUCTED MEASUREMENT:

The transmitter output was connected to the spectrum analyzer via a low loss cable. Set both RBW and VBW of spectrum analyzer to 1MHz and 3MHz with suitable frequency span including 100MHz bandwidth from band edge. The band edges was measured and recorded.

##### FOR RADIATED MEASUREMENT:

- a. The EUT was placed on the top of a rotating table 0.8 meters above the ground at a 3 meter semi-anechoic chamber. The table was rotated 360 degrees to determine the position of the highest radiation.
- b. The EUT was set 3 meters away from the interference-receiving antenna, which was mounted on the top of a variable-height antenna tower.
- c. The antenna is a broadband antenna, and its height is varied from one meter to four meters above the ground to determine the maximum value of the field strength. Both horizontal and vertical polarizations of the antenna are set to make the measurement.
- d. For each suspected emission, the EUT was arranged to its worst case and then the antenna was tuned to heights from 1 meter to 4 meters and the rotatable table was turned from 0 degrees to 360 degrees to find the maximum reading.
- e. Set both RBW and VBW of spectrum analyzer to 1MHz and 3MHz with suitable frequency span including 100MHz bandwidth from band edge. The band edges was measured and recorded.

**NOTE:** The resolution bandwidth of test receiver/spectrum analyzer is 1MHz and the video bandwidth is 10Hz for Average detection (AV) at frequency above 1GHz

#### 4.7.3 EUT OPERATING CONDITION

The software provided by client to enable the EUT under transmission condition continuously at specific channel frequencies individually.

#### 4.7.4 TEST RESULTS

For signals in the restricted bands above and below the 5.15 to 5.25GHz allocated band a measurement was made of the amplitude of the spurious emissions with respect to the intentional signals. The relative amplitude, in dBc, was applied to the average and peak field strength of the intentional signal made on the OATS to calculate the field strength of the unintentional signals.

The spectrum plots (Peak RBW = 1MHz, VBW = 3MHz) are attached on the following pages.

#### 802.11a OFDM MODULATION

##### Channel 36 (5180MHz)

The band edge emission plot on the next page shows 50.71dBc between carrier maximum power and local maximum emission in restrict band. The emission of carrier strength list in the test result of channel 36 is 111.21dBuV/m (Peak), so the maximum field strength in restrict band is  $111.21 - 50.71 = 60.50$ dBuV/m which is under 74dBuV/m limit.

The band edge emission plot on the next page shows 57.19dBc between carrier maximum power and local maximum emission in restrict band. The emission of carrier strength list in the test result of channel 36 is 99.98dBuV/m (Average), so the maximum field strength in restrict band is  $99.98 - 57.19 = 42.79$ dBuV/m which is under 54dBuV/m limit.

##### Channel 48 (5240MHz)

The band edge emission plot on the next second page shows 53.30dBc between carrier maximum power and local maximum emission in restrict band. The emission of carrier strength list in the test result of channel 48 is 111.42dBuV/m (Peak), so the maximum field strength in restrict band is  $111.42 - 53.30 = 58.12$ dBuV/m which is under 74dBuV/m limit.

The band edge emission plot on the next third page shows 55.76dBc between carrier maximum power and local maximum emission in restrict band. The emission of carrier strength list in the test result of channel 48 is 100.07dBuV/m (Average), so the maximum field strength in restrict band is  $100.07 - 55.76 = 44.31$ dBuV/m which is under 54dBuV/m limit.

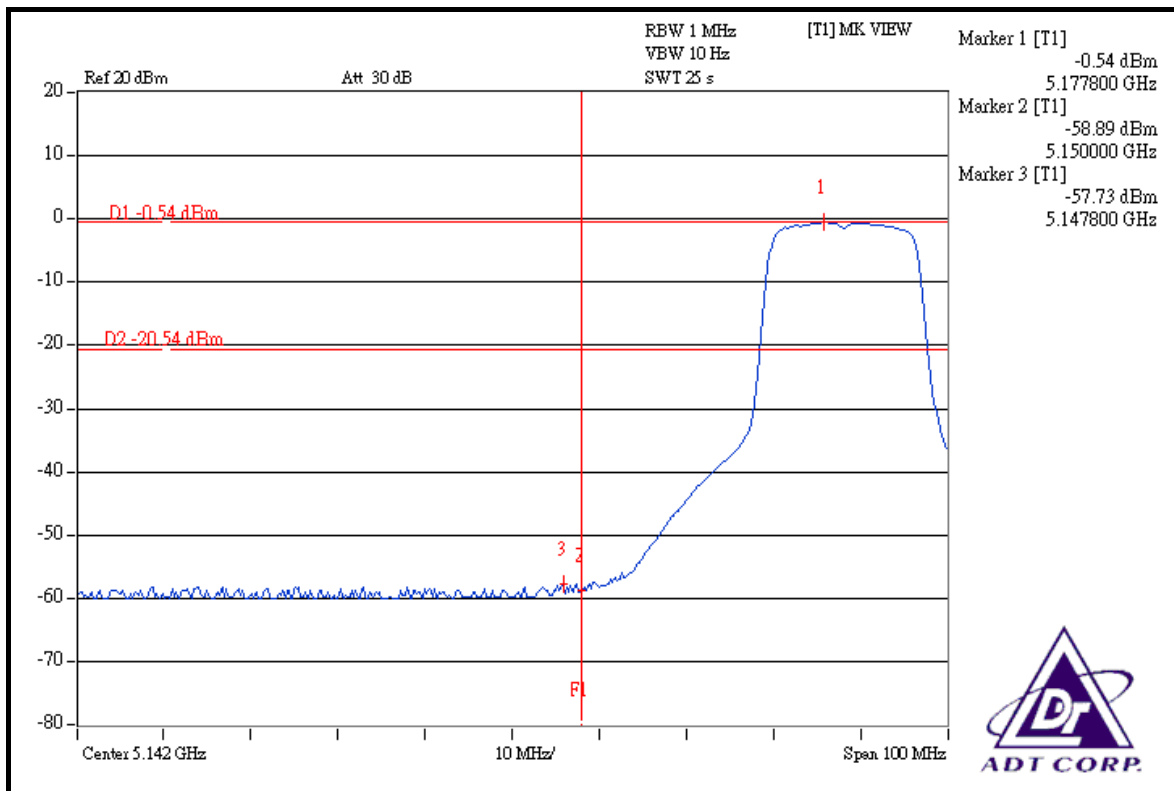
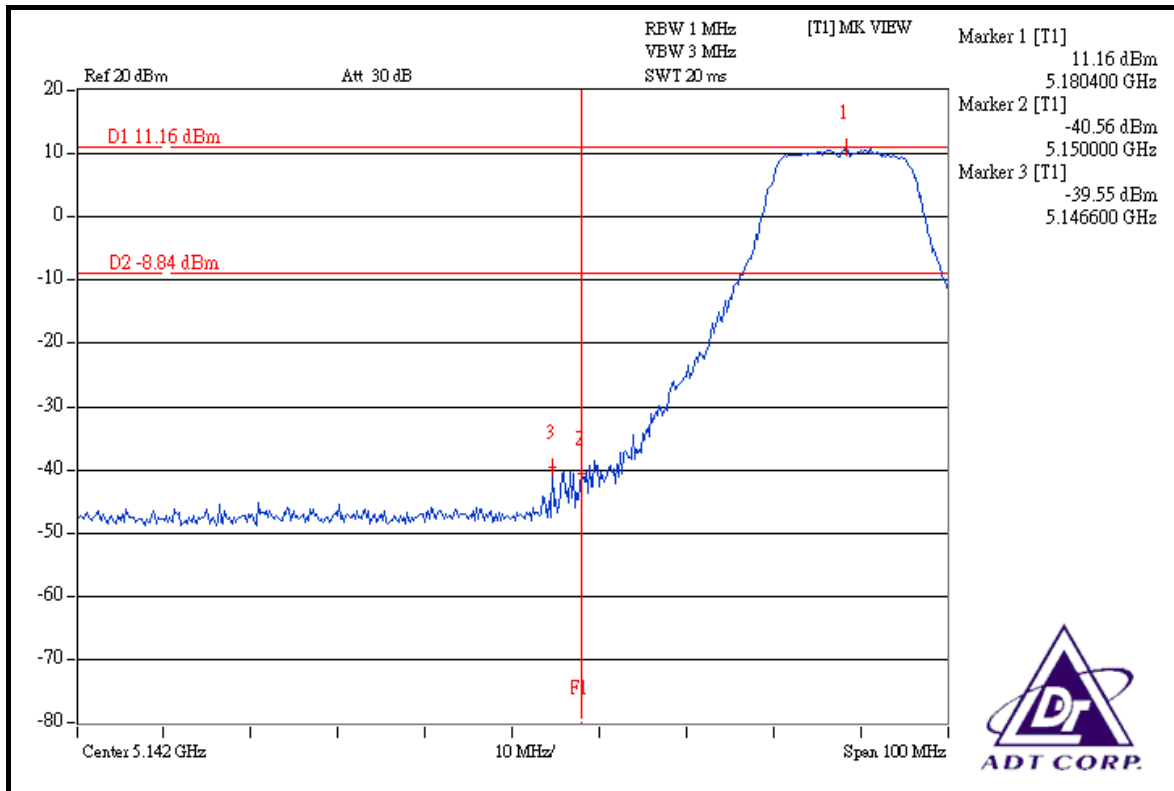

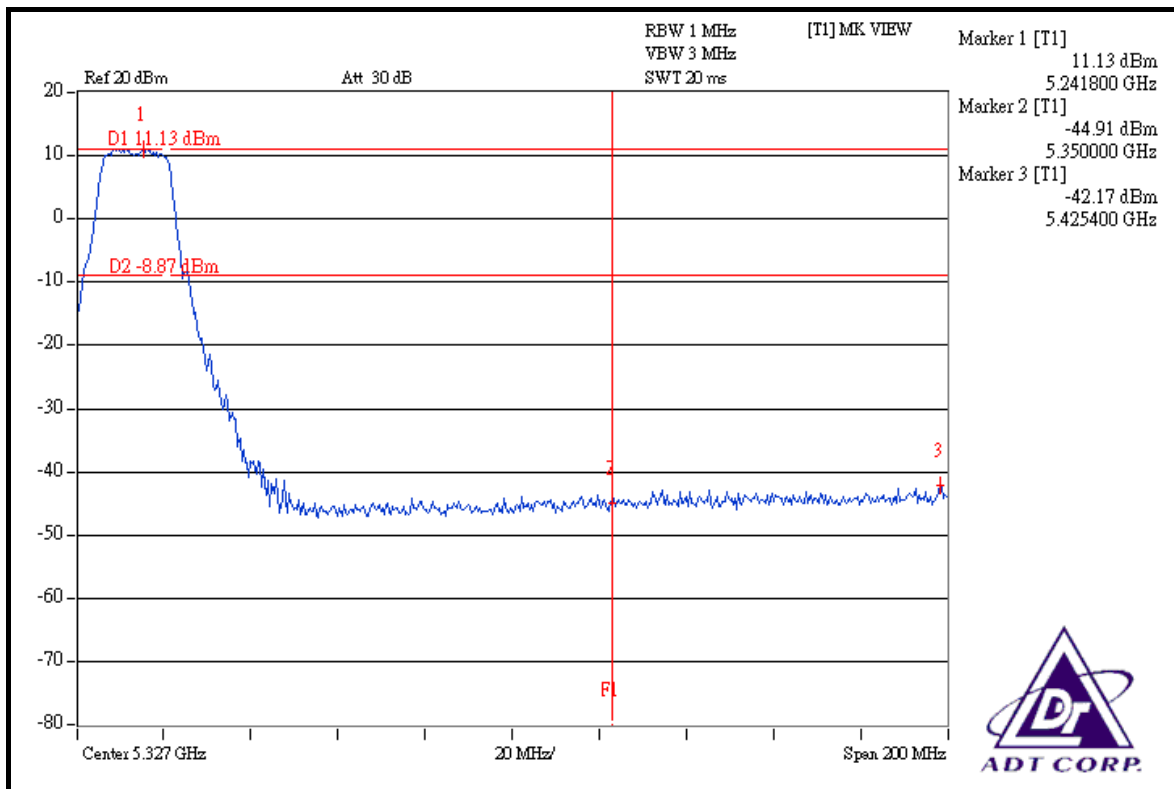
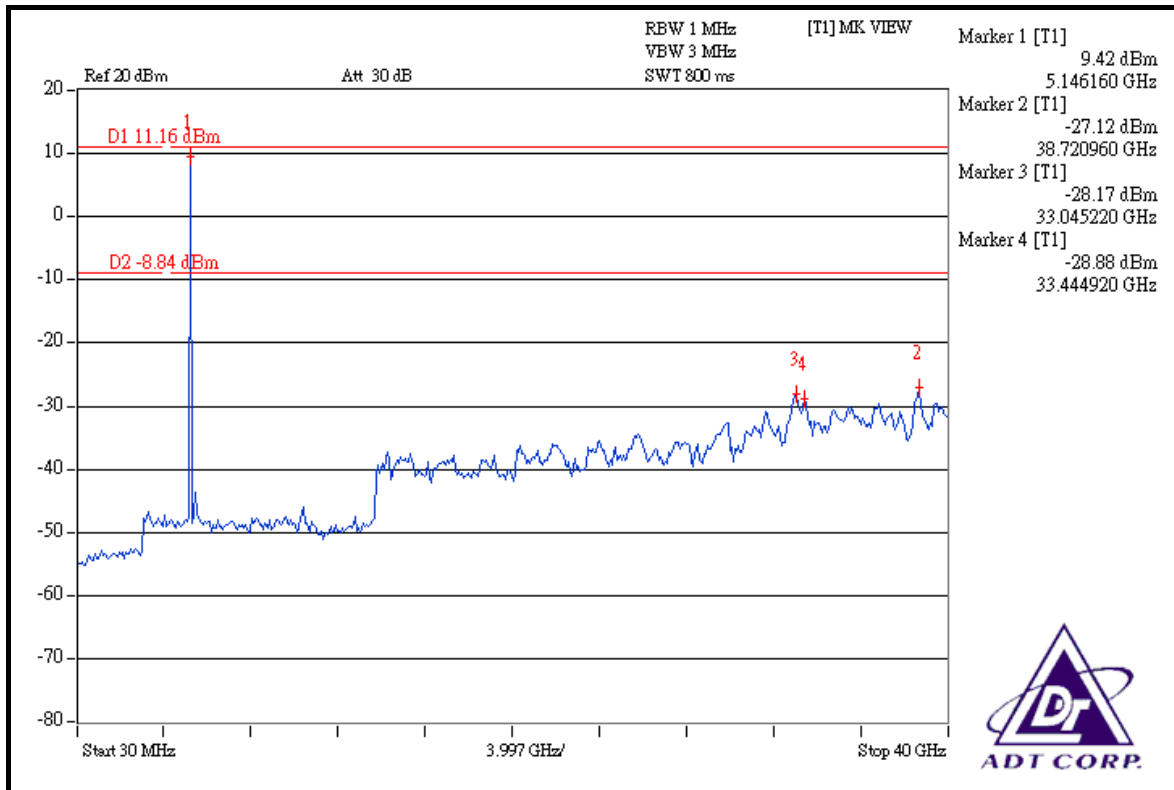

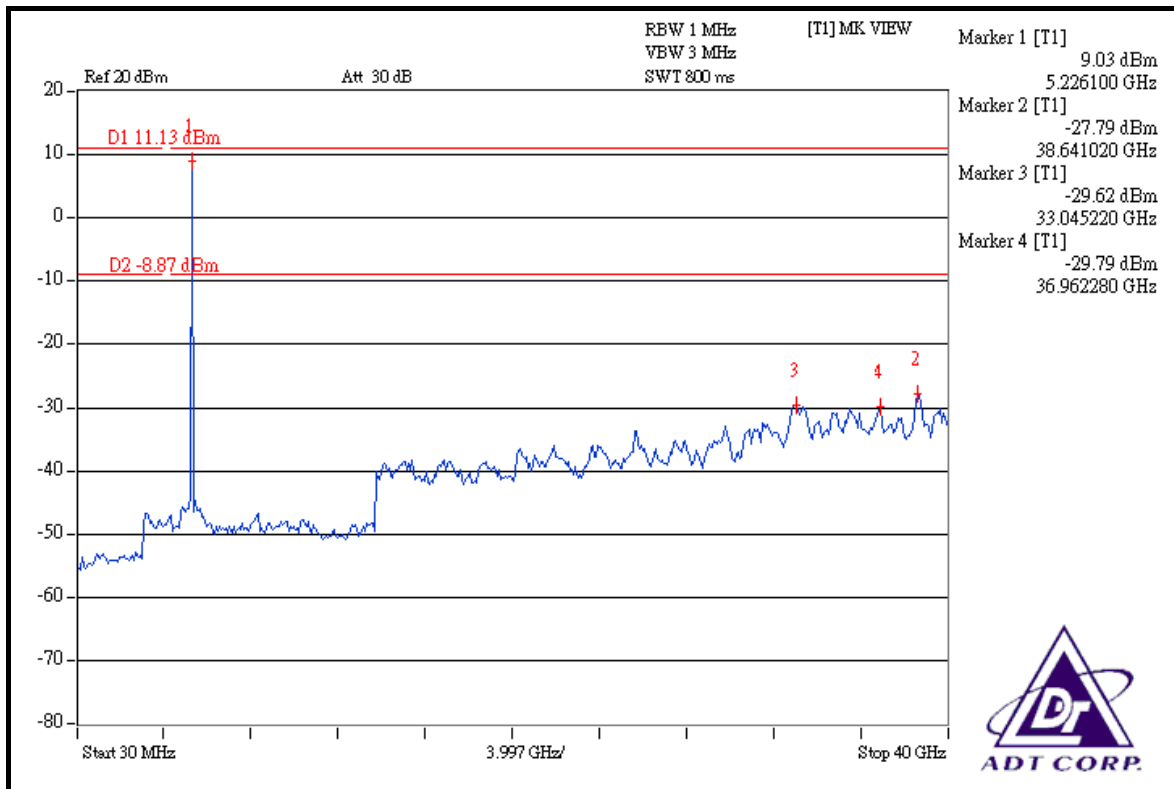
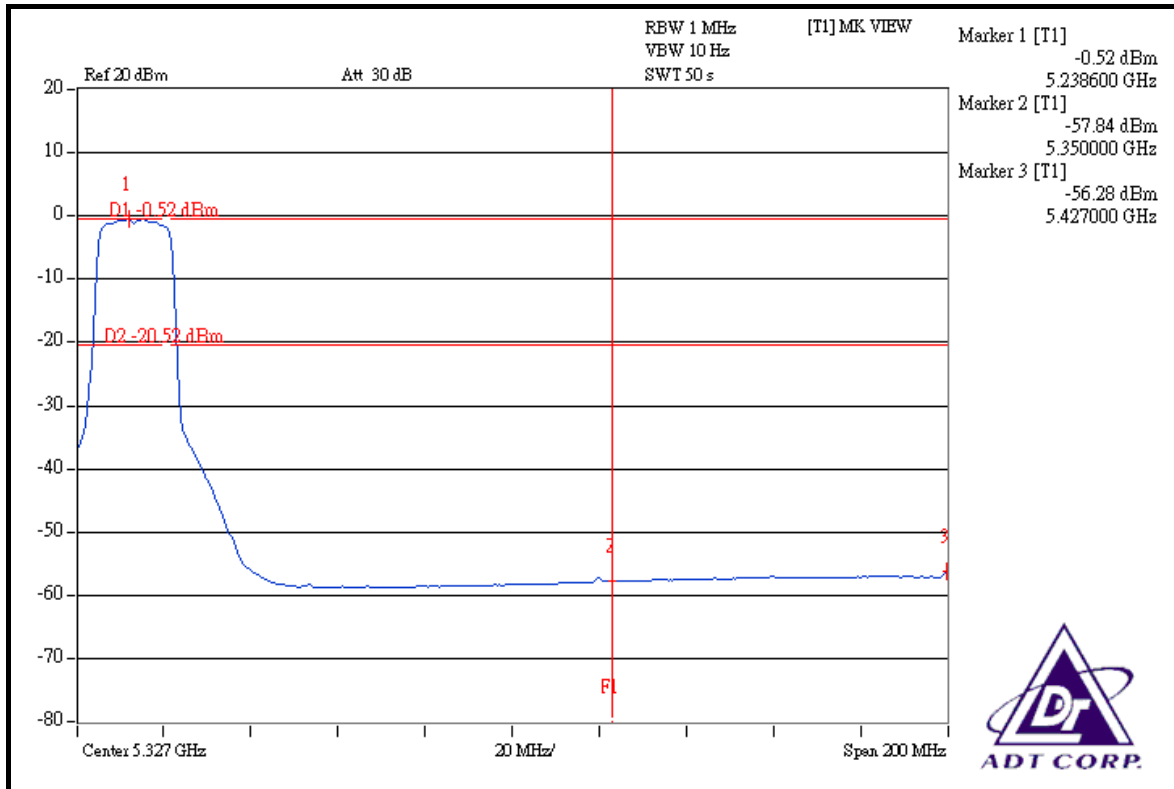



## **DRAFT 802.11n (20MHz) OFDM MODULATION**

### **Channel 36 (5180MHz)**

The band edge emission plot on the next page shows 52.20dBc between carrier maximum power and local maximum emission in restrict band. The emission of carrier strength list in the test result of channel 36 is 110.69dBuV/m (Peak), so the maximum field strength in restrict band is  $110.69 - 52.20 = 58.49$ dBuV/m which is under 74dBuV/m limit.

The band edge emission plot on the next page shows 54.40dBc between carrier maximum power and local maximum emission in restrict band. The emission of carrier strength list in the test result of channel 36 is 100.00dBuV/m (Average), so the maximum field strength in restrict band is  $100.00 - 54.40 = 45.60$ dBuV/m which is under 54dBuV/m limit.

### **Channel 48 (5240MHz)**

The band edge emission plot on the next second page shows 50.78dBc between carrier maximum power and local maximum emission in restrict band. The emission of carrier strength list in the test result of channel 48 is 110.41dBuV/m (Peak), so the maximum field strength in restrict band is  $110.41 - 50.78 = 59.63$ dBuV/m which is under 74dBuV/m limit.

The band edge emission plot on the next third page shows 54.26dBc between carrier maximum power and local maximum emission in restrict band. The emission of carrier strength list in the test result of channel 48 is 99.68dBuV/m (Average), so the maximum field strength in restrict band is  $99.68 - 54.26 = 45.42$ dBuV/m which is under 54dBuV/m limit.

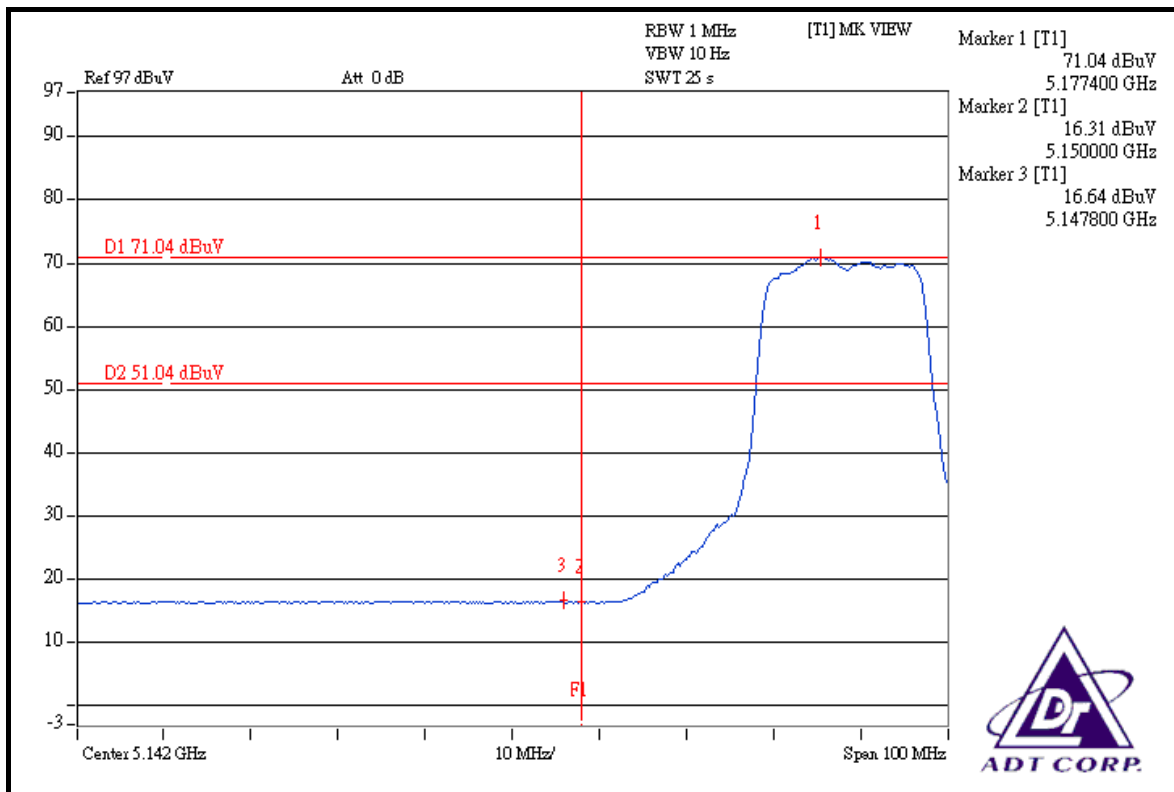
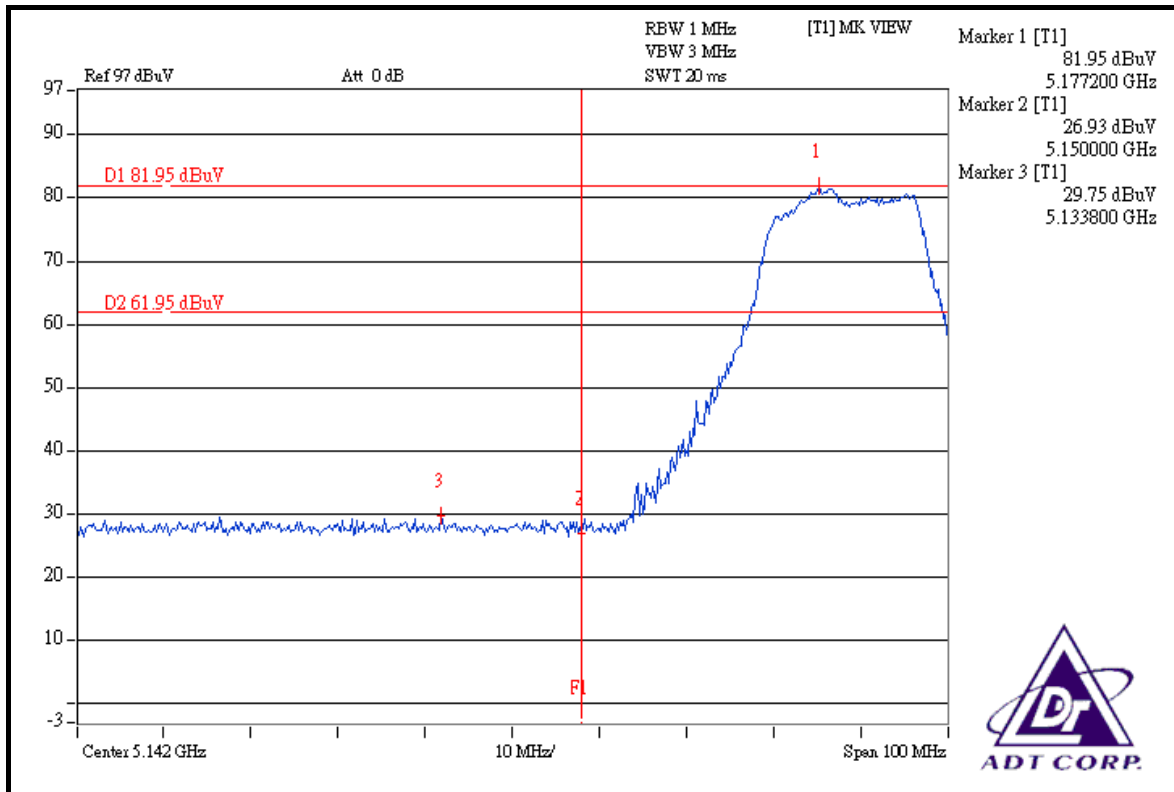

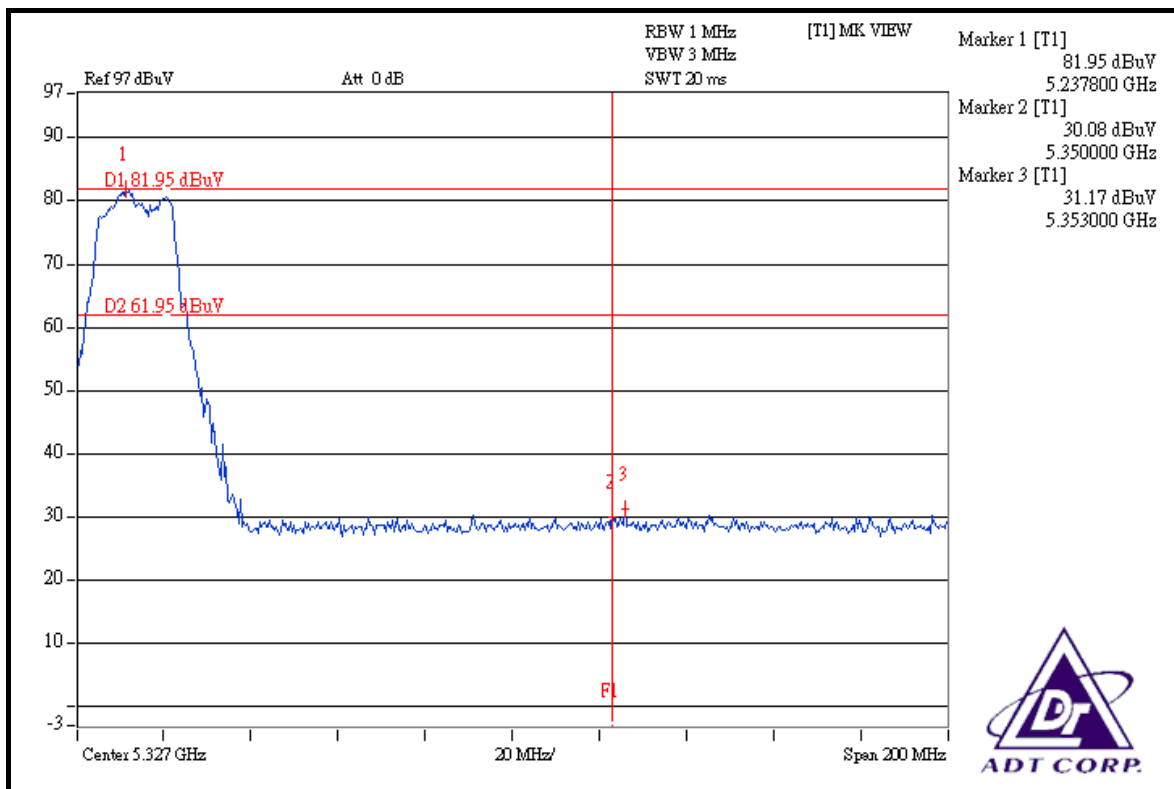
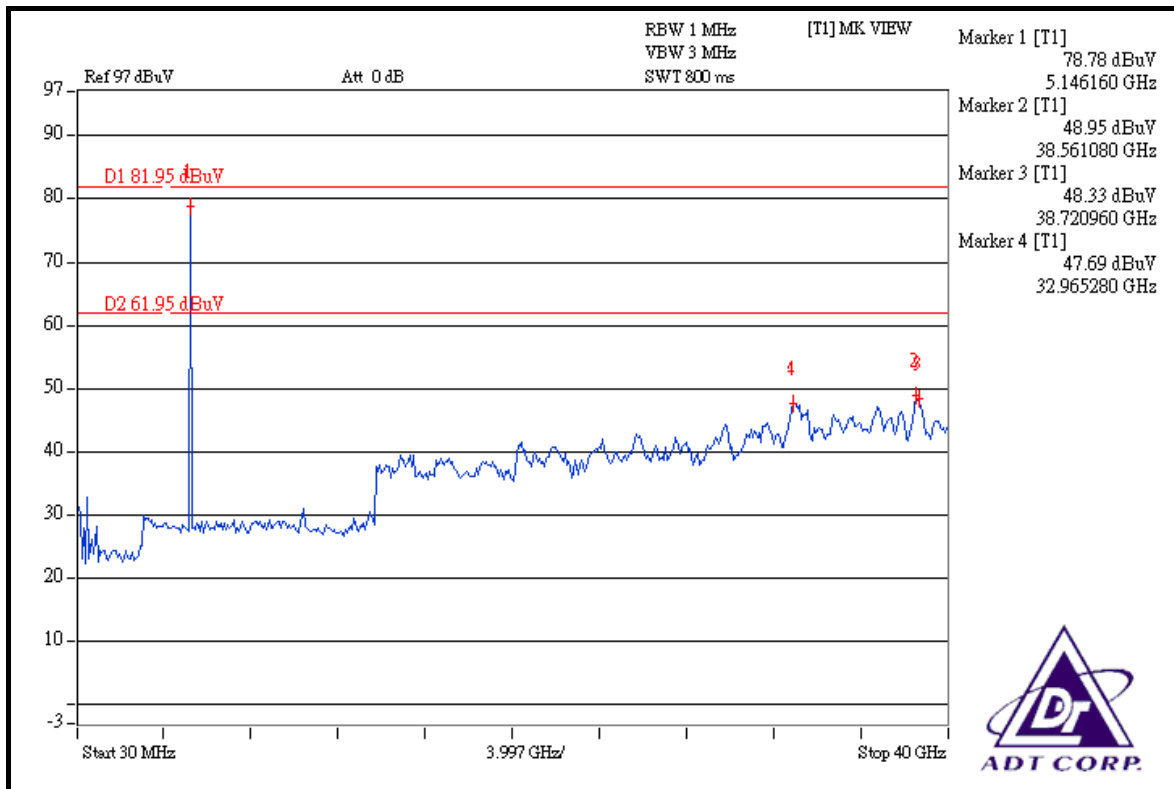

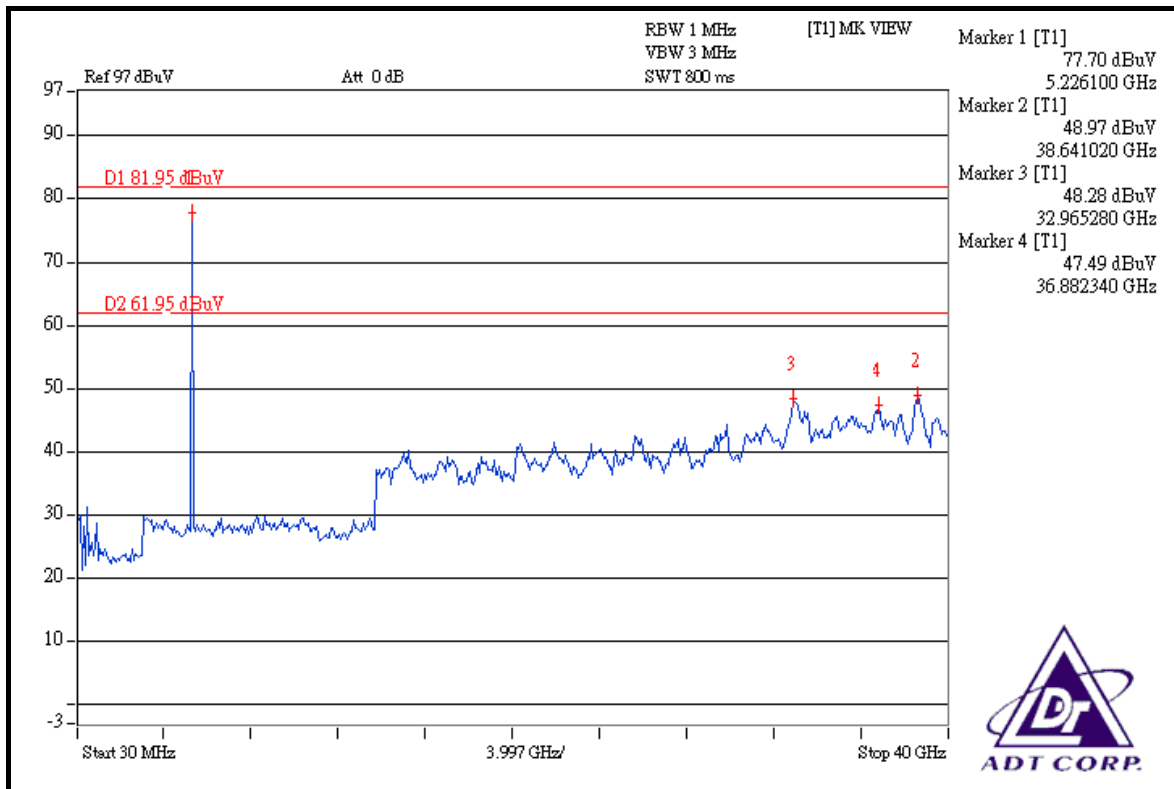
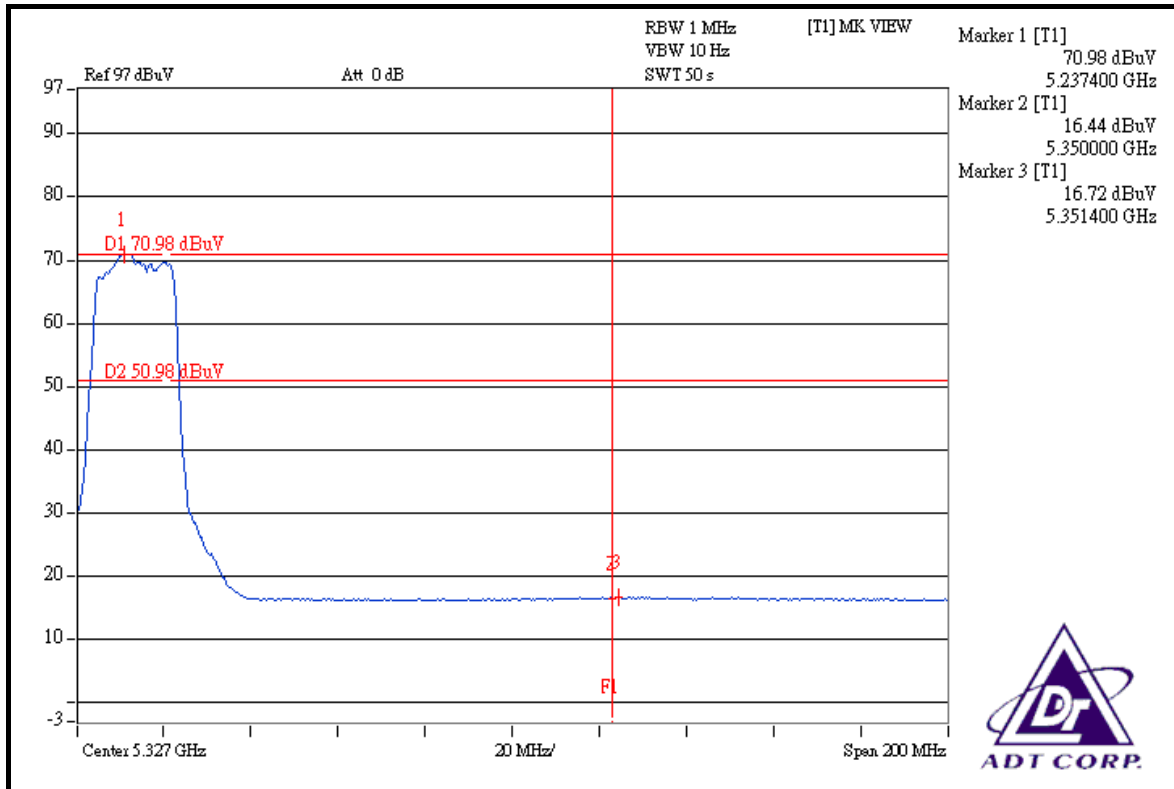

## **DRAFT 802.11n (40MHz) OFDM MODULATION**

### **Channel 38 (5190MHz)**

The band edge emission plot on the next page shows 43.51dBc between carrier maximum power and local maximum emission in restrict band. The emission of carrier strength list in the test result of channel 38 is 110.15dBuV/m (Peak), so the maximum field strength in restrict band is  $110.15 - 43.51 = 66.64$ dBuV/m which is under 74dBuV/m limit.

The band edge emission plot on the next page shows 50.68dBc between carrier maximum power and local maximum emission in restrict band. The emission of carrier strength list in the test result of channel 38 is 99.84dBuV/m (Average), so the maximum field strength in restrict band is  $99.84 - 50.68 = 49.16$ dBuV/m which is under 54dBuV/m limit.

### **Channel 46 (5230MHz)**

The band edge emission plot on the next second page shows 49.80dBc between carrier maximum power and local maximum emission in restrict band. The emission of carrier strength list in the test result of channel 46 is 110.33dBuV/m (Peak), so the maximum field strength in restrict band is  $110.33 - 49.80 = 60.53$ dBuV/m which is under 74dBuV/m limit.

The band edge emission plot on the next third page shows 52.84dBc between carrier maximum power and local maximum emission in restrict band. The emission of carrier strength list in the test result of channel 46 is 100.04dBuV/m (Average), so the maximum field strength in restrict band is  $100.04 - 52.84 = 47.20$ dBuV/m which is under 54dBuV/m limit.

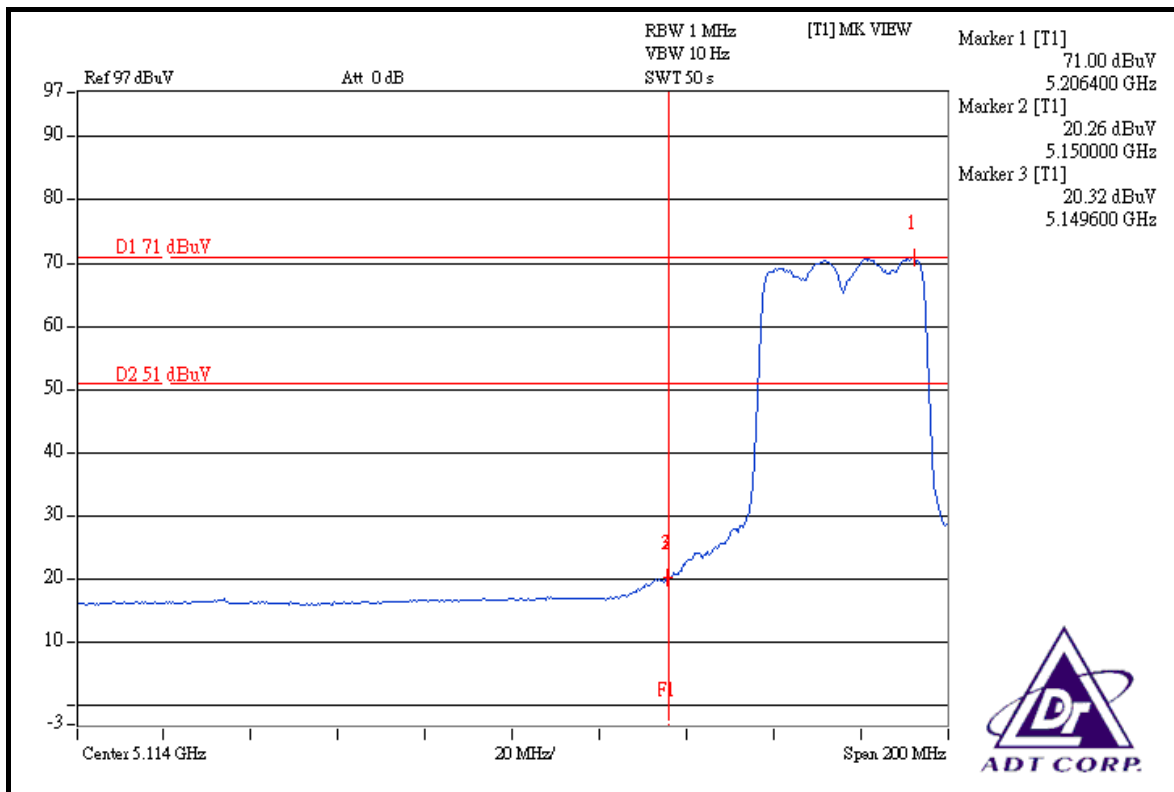
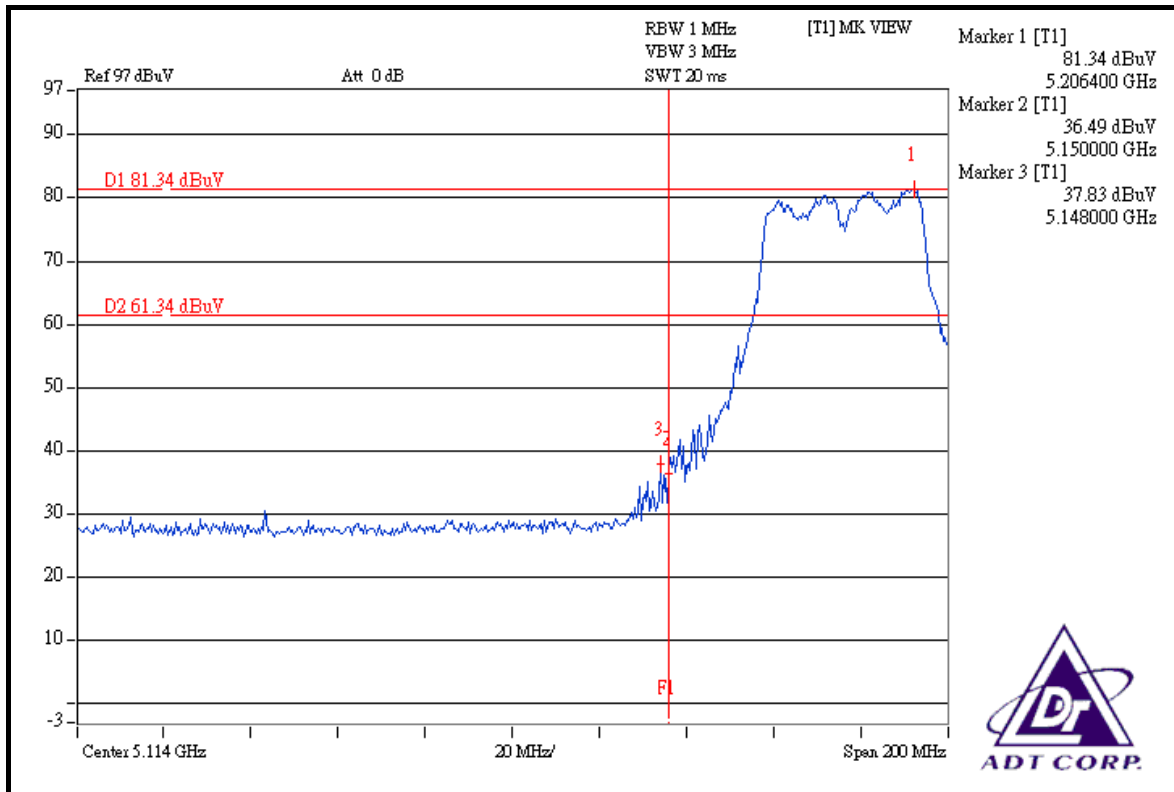

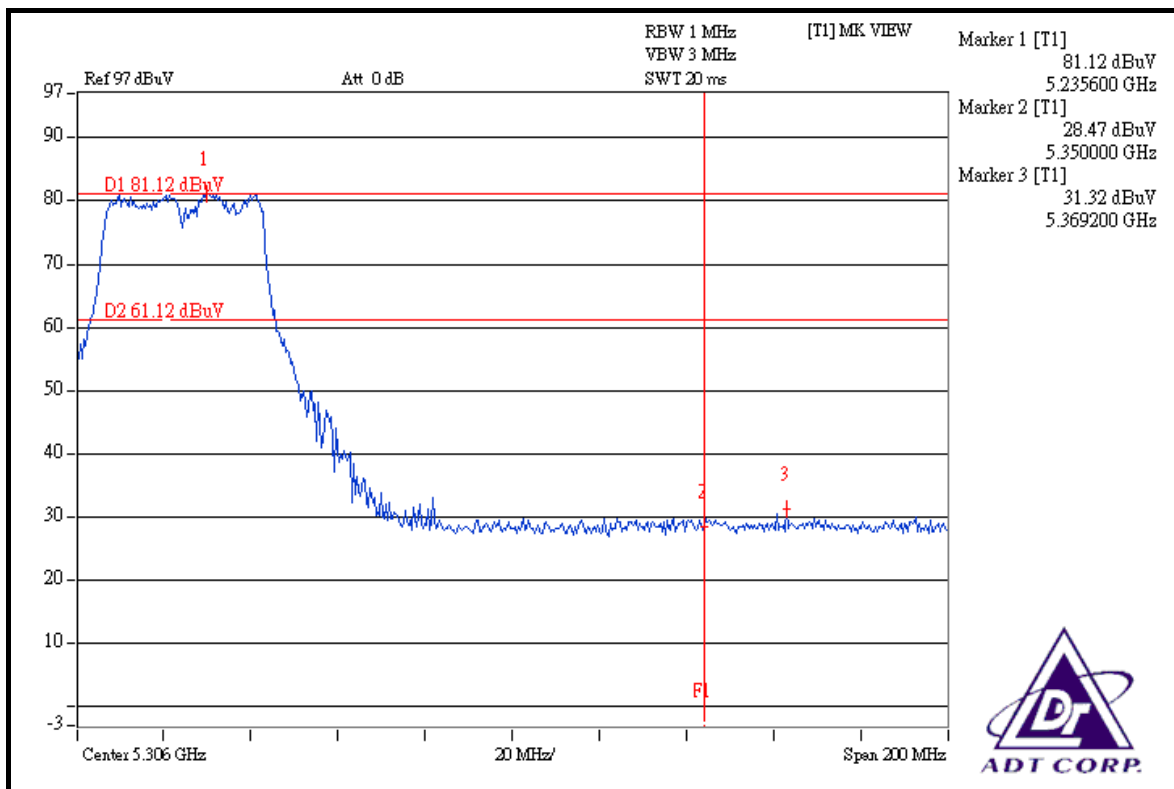
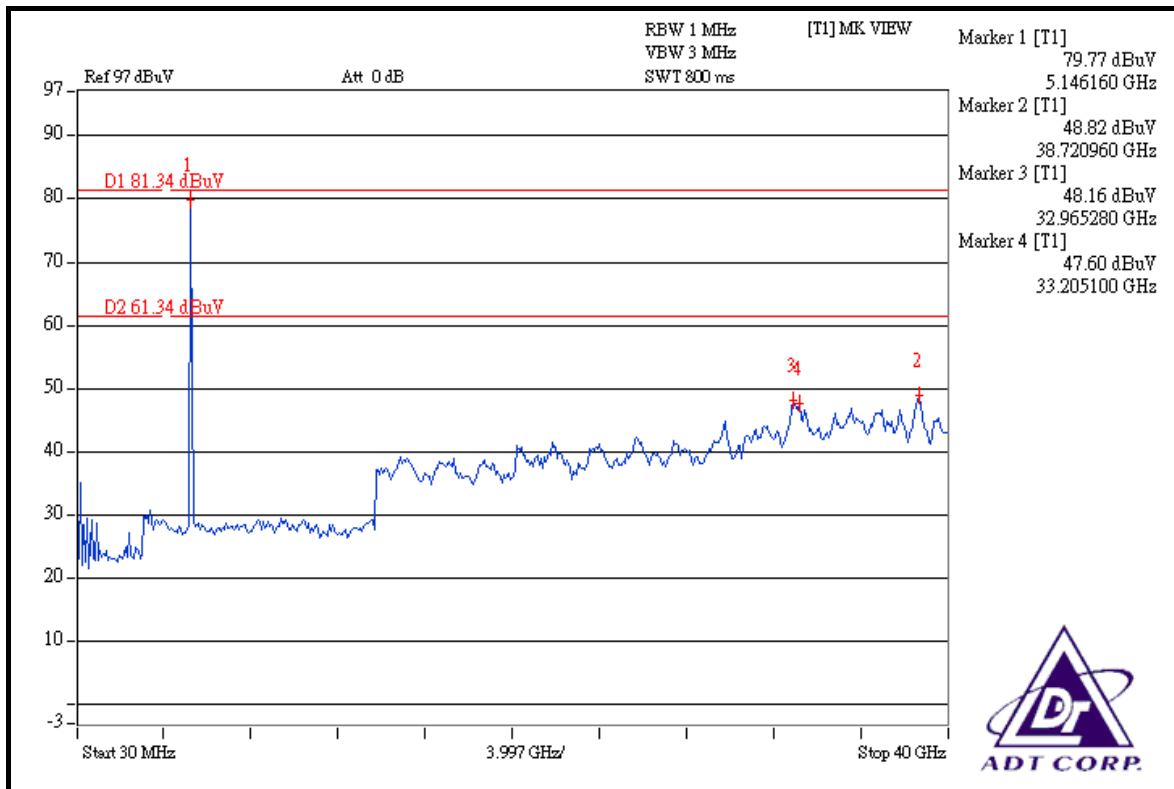

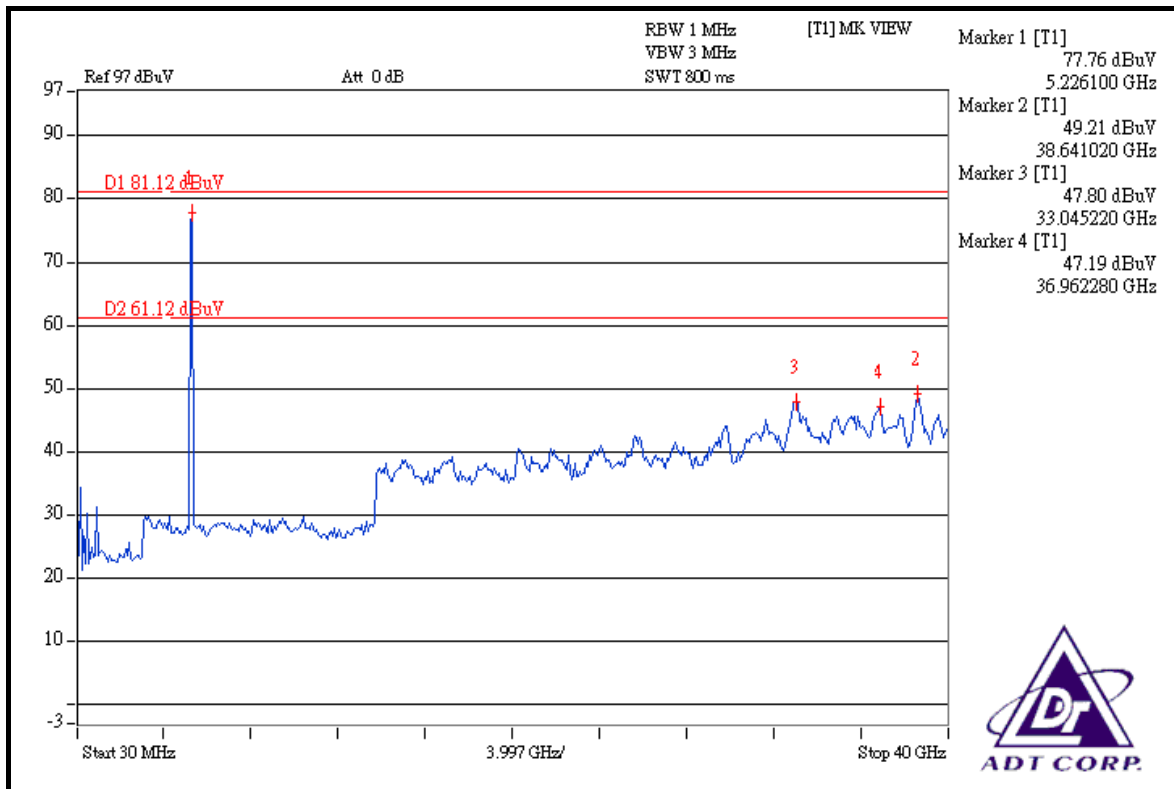
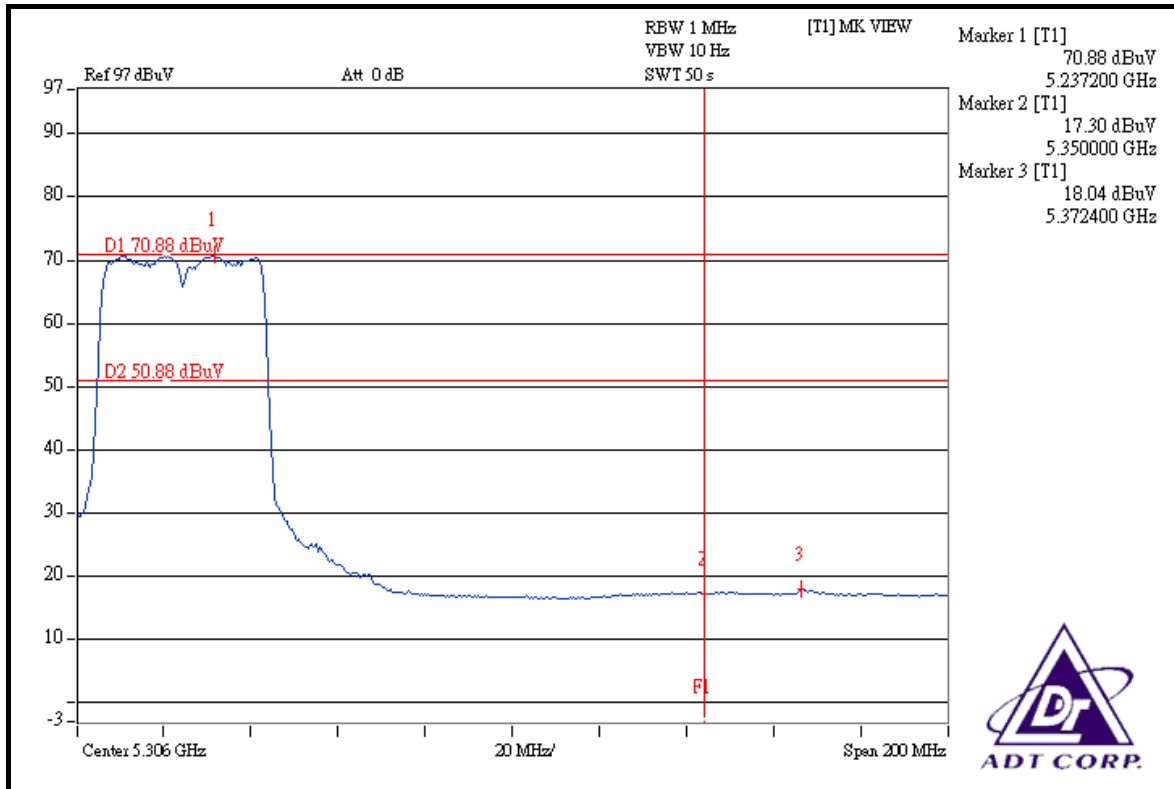





## **4.8 ANTENNA REQUIREMENT**

### **4.8.1 STANDARD APPLICABLE**

For intentional device, according to FCC 47 CFR Section 15.203, an intentional radiator shall be designed to ensure that no antenna other than that furnished by the responsible party shall be used with the device.

And according to FCC 47 CFR Section 15.407(a), if transmitting antennas of directional gain greater than 6dBi are used, the power shall be reduced by the amount in dB that the directional gain of the antenna exceeds 6dBi.

### **4.8.2 ANTENNA CONNECTED CONSTRUCTION**

The antenna used in this product is Dipole antenna with R-SMA connector. The maximum Gain of the antenna is 2dBi.



## **5. PHOTOGRAPHS OF THE TEST CONFIGURATION**

Please refer to the attached file (Test Setup Photo).



## 6. INFORMATION ON THE TESTING LABORATORIES

We, ADT Corp., were founded in 1988 to provide our best service in EMC, Radio, Telecom and Safety consultation. Our laboratories are accredited and approved by the following approval agencies according to ISO/IEC 17025.

|                    |                       |
|--------------------|-----------------------|
| <b>USA</b>         | FCC, UL, A2LA         |
| <b>Germany</b>     | TUV Rheinland         |
| <b>Japan</b>       | VCCI                  |
| <b>Norway</b>      | NEMKO                 |
| <b>Canada</b>      | INDUSTRY CANADA , CSA |
| <b>R.O.C.</b>      | TAF, BSMI, NCC        |
| <b>Netherlands</b> | Telefication          |
| <b>Singapore</b>   | GOST-ASIA(MOU)        |
| <b>Russia</b>      | CERTIS(MOU)           |

Copies of accreditation certificates of our laboratories obtained from approval agencies can be downloaded from our web site:  
[www.adt.com.tw/index.5/phtml](http://www.adt.com.tw/index.5/phtml). If you have any comments, please feel free to contact us at the following:

**Linko EMC/RF Lab:**  
Tel: 886-2-26052180  
Fax: 886-2-26051924

**Hsin Chu EMC/RF Lab:**  
Tel: 886-3-5935343  
Fax: 886-3-5935342

**Hwa Ya EMC/RF/Safety Telecom Lab:**  
Tel: 886-3-3183232  
Fax: 886-3-3185050

**Web Site:** [www.adt.com.tw](http://www.adt.com.tw)

The address and road map of all our labs can be found in our web site also.



## **7. APPENDIX A - MODIFICATIONS RECORDERS FOR ENGINEERING CHANGES TO THE EUT BY THE LAB**

No any modifications are made to the EUT by the lab during the test.