



## Test Report

Product Name : Wireless N Day/Night Home Network Camera  
Model No. : DCS-932, DCS-932L, DCS-930\_A2,  
DCS-930L\_A2  
FCC ID. : KA2CS932LA1

Applicant : D-Link Corporation  
Address : No.289, Sinhu 3rd Rd., Neihu District, Taipei  
City 114, Taiwan, R.O.C.

Date of Receipt : 2010/10/08  
Issued Date : 2011/01/17  
Report No. : 10A242R-RFUSP42V01  
Report Version : V2.0

The test results relate only to the samples tested.

The test report shall not be reproduced except in full without the written approval of Quietek Corporation.

---

# Test Report Certification

Issued Date : 2011/01/17

Report No. : 10A242R-RFUSP42V01



Product Name : Wireless N Day/Night Home Network Camera  
 Applicant : D-Link Corporation  
 Address : No.289, Sinhu 3rd Rd., Neihu District, Taipei City 114,  
 Taiwan, R.O.C.  
 Manufacturer : Alpha Networks Inc.  
 MODEL NO. : DCS-932, DCS-932L, DCS-930\_A2, DCS-930L\_A2  
 FCC ID. : KA2CS932LA1  
 EUT Voltage : AC 100-240V / 50/60Hz  
 Trade Name : D-Link  
 Applicable Standard : FCC CFR Title 47 Part 15 Subpart C Section 15.247:2009  
 Test Result : Complied

The test results relate only to the samples tested.

The test report shall not be reproduced except in full without the written approval of Quietek Corporation.

Documented By : Carol Tsai  
 ( Carol Tsai / Engineering Adm. Specialist )

Reviewed By : Sheena Huang  
 ( Sheena Huang / Engineer )

Approved By : Roy Wang  
 ( Roy Wang / Manager )

## TABLE OF CONTENTS

Description	Page
<b>1. General Information.....</b>	<b>5</b>
1.1. EUT Description .....	5
1.2. Operational Description .....	9
1.3. Test Mode .....	10
1.4. Tested System Details .....	11
1.5. Configuration of tested System .....	11
1.6. EUT Exercise Software.....	12
1.7. Test Facility.....	13
<b>2. Conducted Emission .....</b>	<b>14</b>
2.1. Test Equipment.....	14
2.2. Test Setup.....	14
2.3. Limits .....	15
2.4. Test Procedure .....	15
2.5. Test Specification .....	15
2.6. Uncertainty .....	15
2.7. Test Result.....	16
2.8. Test Photo.....	20
<b>3. Peak Power Output.....</b>	<b>22</b>
3.1. Test Equipment.....	22
3.2. Test Setup.....	22
3.3. Test procedures .....	22
3.4. Limits .....	22
3.5. Test Specification .....	22
3.6. Uncertainty .....	22
3.7. Test Result.....	23
<b>4. Radiated Emission.....</b>	<b>27</b>
4.1. Test Equipment.....	27
4.2. Test Setup.....	27
4.3. Limits .....	28
4.4. Test Procedure .....	28
4.5. Test Specification .....	28
4.6. Uncertainty .....	28
4.7. Test Result.....	29
4.8. Test Photo.....	69

<b>5. RF antenna conducted test.....</b>	<b>72</b>
5.1. Test Equipment.....	72
5.2. Test Setup.....	72
5.3. Limits .....	73
5.4. Test Procedure .....	73
5.5. Test Specification .....	73
5.6. Uncertainty .....	73
5.7. Test Result.....	74
<b>6. Radiated Emission Band Edge.....</b>	<b>130</b>
6.1. Test Equipment.....	130
6.2. Test Setup.....	130
6.3. Limits .....	131
6.4. Test Procedure .....	131
6.5. Test Specification .....	131
6.6. Uncertainty .....	131
6.7. Test Result.....	132
<b>7. Occupied Bandwidth .....</b>	<b>164</b>
7.1. Test Equipment.....	164
7.2. Test Setup.....	164
7.3. Test Procedures.....	164
7.4. Limits .....	164
7.5. Test Specification .....	164
7.6. Uncertainty .....	164
7.7. Test Result.....	165
<b>8. Power Density .....</b>	<b>177</b>
8.1. Test Equipment.....	177
8.2. Test Setup.....	177
8.3. Limits .....	177
8.4. Test Procedures.....	177
8.5. Test Specification .....	177
8.6. Uncertainty .....	177
8.7. Test Result.....	178
Attachement .....	190
EUT Photograph.....	190

## 1. General Information

### 1.1. EUT Description

Product Name	Wireless N Day/Night Home Network Camera
Product Type	WLAN (1TX, 1RX)
Trade Name	D-Link
Model No.	DCS-932, DCS-932L, DCS-930_A2, DCS-930L_A2
Frequency Range -IEEE 802.11b/g & IEEE 802.11n (20MHz)	2412~2462MHz
Frequency Range- IEEE 802.11n (40MHz)	2422~2452MHz
Channel Number (IEEE 802.11b/g & IEEE 802.11n (20MHz))	11
Channel Number- IEEE 802.11n (40MHz)	7
Type of Modulation (IEEE 802.11b)	Direct Sequence Spread Spectrum (DSSS)
Type of Modulation (IEEE 802.11g/n)	Orthogonal Frequency Division Multiplexing (OFDM)
Data Speed (IEEE 802.11b)	1Mbps, 2Mbps, 5.5Mbps, 11Mbps
Data Speed (IEEE 802.11g)	6Mbps, 9Mbps, 12Mbps, 18Mbps, 24Mbps, 36Mbps, 48Mbps, 54Mbps
Data Speed (IEEE 802.11n)	Support a subset of the combination of GI, MCS 0~MCS 7 and bandwidth defined in 802.11n
Antenna Gain	2.1dBi
Channel Control	Manual
Antenna Type	Multilayers Chip

Component	
LAN Cable	Non-Shielded, 1.5m
Power Adapter	D-Link, AMS1-0501200FU I/P: 100-240V ~ 50/60Hz, 0.2A O/P: 5V === 1.2A Cable Out: Non-Shielded, 1.5m
Power Adapter	D-Link, MU06-9050120-A1 I/P: 100-240V ~ 50/60Hz, 0.2A O/P: 5V === 1.2A Cable Out: Non-Shielded, 1.5m

**ANT-TX / Rx & Bandwidth**

ANT-TX / Rx	TX		Rx	
Mode/ Channel Bandwidth	20MHz	40MHz	20MHz	40MHz
IEEE802.11b	✓		✓	
IEEE802.11g	✓			
IEEE802.11n	✓	✓	✓	✓

**ANT (TX / RX)**

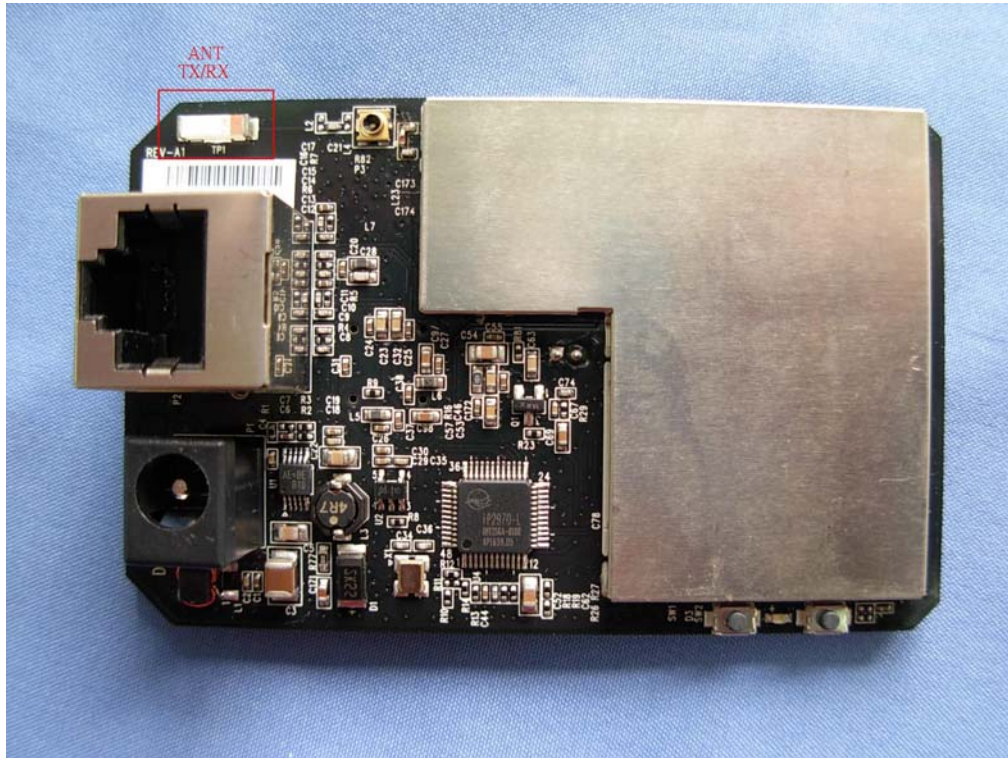

**IEEE802.11n Spec.**

MCS Index	Modulation	R	N <sub>BPSCS</sub>	N <sub>CBPS</sub>		N <sub>DBPS</sub>		Data Rate(Mb/s)			
				20MHz	40MHz	20MHz	40MHz	800ns GI		400ns GI (Note1)	
								20MHz	40MHz	20MHz	40MHz
0	BPSK	1/2	1	52	108	26	54	6.5	13.5	7.2	15.0
1	QPSK	1/2	2	104	216	52	108	13.0	27.0	14.4	30.0
2	QPSK	3/4	2	104	216	78	162	19.5	40.5	21.7	45.0
3	16-QAM	1/2	4	208	432	104	216	26.0	54.0	28.9	60.0
4	16-QAM	3/4	4	208	432	156	324	39.0	81.0	43.3	90.0
5	64-QAM	2/3	6	312	648	208	432	52.0	108.0	57.8	120.0
6	64-QAM	3/4	6	312	648	234	486	58.5	121.5	65.0	135.0
7	64-QAM	5/6	6	312	648	260	540	65.0	135.0	72.2	150.0

Note 1: Support of 400ns GI is optional on transmit and receive.

Table 1 – MCS parameters for TX Antenna number = 1

MCS Index	Modulation	R	N <sub>BPSCS</sub>	N <sub>CBPS</sub>		N <sub>DBPS</sub>		Data Rate(Mb/s)			
				20MHz	40MHz	20MHz	40MHz	800ns GI		400ns GI (Note1)	
								20MHz	40MHz	20MHz	40MHz
8	BPSK	1/2	1	104	216	52	108	13.0	27.0	14.4	30.0
9	QPSK	1/2	2	208	432	104	216	26.0	54.0	28.9	60.0
10	QPSK	3/4	2	208	432	156	324	39.0	81.0	43.3	90.0
11	16-QAM	1/2	4	416	864	208	432	52.0	108.0	57.8	120.0
12	16-QAM	3/4	4	416	864	312	648	78.0	162.0	86.7	180.0
13	64-QAM	2/3	6	624	1296	416	864	104.0	216.0	115.6	240.0
14	64-QAM	3/4	6	624	1296	468	972	117.0	243.0	130.0	270.0
15	64-QAM	5/6	6	624	1296	520	1080	130.0	270.0	144.4	300.0

Note 1: Support of 400ns GI is optional on transmit and receive.

Table 2 – MCS parameters for TX Antenna number = 2

Symbol	Explanation
R	Code rate
N <sub>BPSC</sub>	Number of coded bits per single carrier
N <sub>CBPS</sub>	Number of coded bits per symbol
N <sub>DBPS</sub>	Number of data bits per symbol
GI	guard interval

IEEE 802.11b/g & IEEE 802.11n (20MHz)

Working Frequency of Each Channel							
Channel	Frequency	Channel	Frequency	Channel	Frequency	Channel	Frequency
001	2412 MHz	002	2417 MHz	003	2422 MHz	004	2427 MHz
005	2432 MHz	006	2437 MHz	007	2442 MHz	008	2447 MHz
009	2452 MHz	010	2457 MHz	011	2462 MHz		

IEEE 802.11n (40MHz)

Working Frequency of Each Channel							
Channel	Frequency	Channel	Frequency	Channel	Frequency	Channel	Frequency
003	2422 MHz	004	2427 MHz	005	2432 MHz	006	2437 MHz
007	2442 MHz	008	2447 MHz	009	2452 MHz		

Note:

1. This device is a Wireless N Day/Night Home Network Camera including 2.4GHz 11 b/g and 11n (1x1) transmitting and receiving function.
2. The differences of each model are show below:

Model	IR Board		Firmware	Remark
	with	without	Support mydlink function	
DCS-932	V			
DCS-932L	V		V	End user may connect to the internet to view the real time image
DCS-930_A2		V		
DCS-930L_A2		V	V	End user may connect to the internet to view the real time image

3. After the pre-test, only the worst case, DCS-932L, was recorded in this report.
4. These test results on a sample of the device are for the purpose of demonstrating compliance with Part 15 Subpart C Paragraph 15.247.
5. Regards to the frequency band operation; the lowest 、 middle and highest frequency of channel were selected to perform the test, and then shown on this report.
6. This device is a composite device in accordance with Part 15 regulations. The receiving function receiving was tested and its test report number is 10A242R-RFUSP37V02 under Declaration of Conformity.



### 1.3. Test Mode

Quietek has verified the construction and function in typical operation. The preliminary tests were performed in different data rate, and to find the worst condition, which was shown in this test report. The following table is the final test mode.

TX	Mode 1: Transmit (Adapter: AMS1-0501200FU) Mode 2: Transmit (Adapter: MU06-9050120-A1)
----	---

Test Items	Mode		Channel	Result
Conducted Emission	1/2	11n (40MHz)	6	Complies
Peak Power Output	1	b/g	1 /6/ 11	Complies
	1	11n(20MHz)	1 /6/ 11	Complies
	1	11n(40MHz)	3 /6/ 9	Complies
Radiated Emission (Under 1GHz)	1/2	b/g	6	Complies
	1/2	11n(20MHz)	6	Complies
	1/2	11n(40MHz)	6	Complies
Radiated Emission (Above 1GHz)	1	b/g	1 /6/ 11	Complies
	1	11n(20MHz)	1 /6/ 11	Complies
	1	11n(40MHz)	3 /6/ 9	Complies
RF antenna conducted test	1	b/g	1 /11	Complies
	1	11n(20MHz)	1 /11	Complies
	1	11n(40MHz)	3 /9	Complies
Radiated Emission Band Edge	1	b/g	1 /11	Complies
	1	11n(20MHz)	1 /11	Complies
	1	11n(40MHz)	3 /9	Complies
Occupied Bandwidth	1	b/g	1 /6/ 11	Complies
	1	11n(20MHz)	1 /6/ 11	Complies
	1	11n(40MHz)	3 /6/ 9	Complies
Power Density	1	b/g	1 /6/ 11	Complies
	1	11n(20MHz)	1 /6/ 11	Complies
	1	11n(40MHz)	3 /6/ 9	Complies

**1.4. Tested System Details**

The types for all equipments, plus descriptions of all cables used in the tested system (including inserted cards) are:

Product	Manufacturer	Model No.	Serial No.	FCC ID	Power Cord	
1	Notebook PC	DELL	LATITUDE D400	GK43D1S	DoC	Non-Shielded, 1.7m, one ferrite core bonded
2	Notebook PC	DELL	LATITUDE D400	HK43D1S	DoC	Non-Shielded, 1.7m, one ferrite core bonded

**1.5. Configuration of tested System**

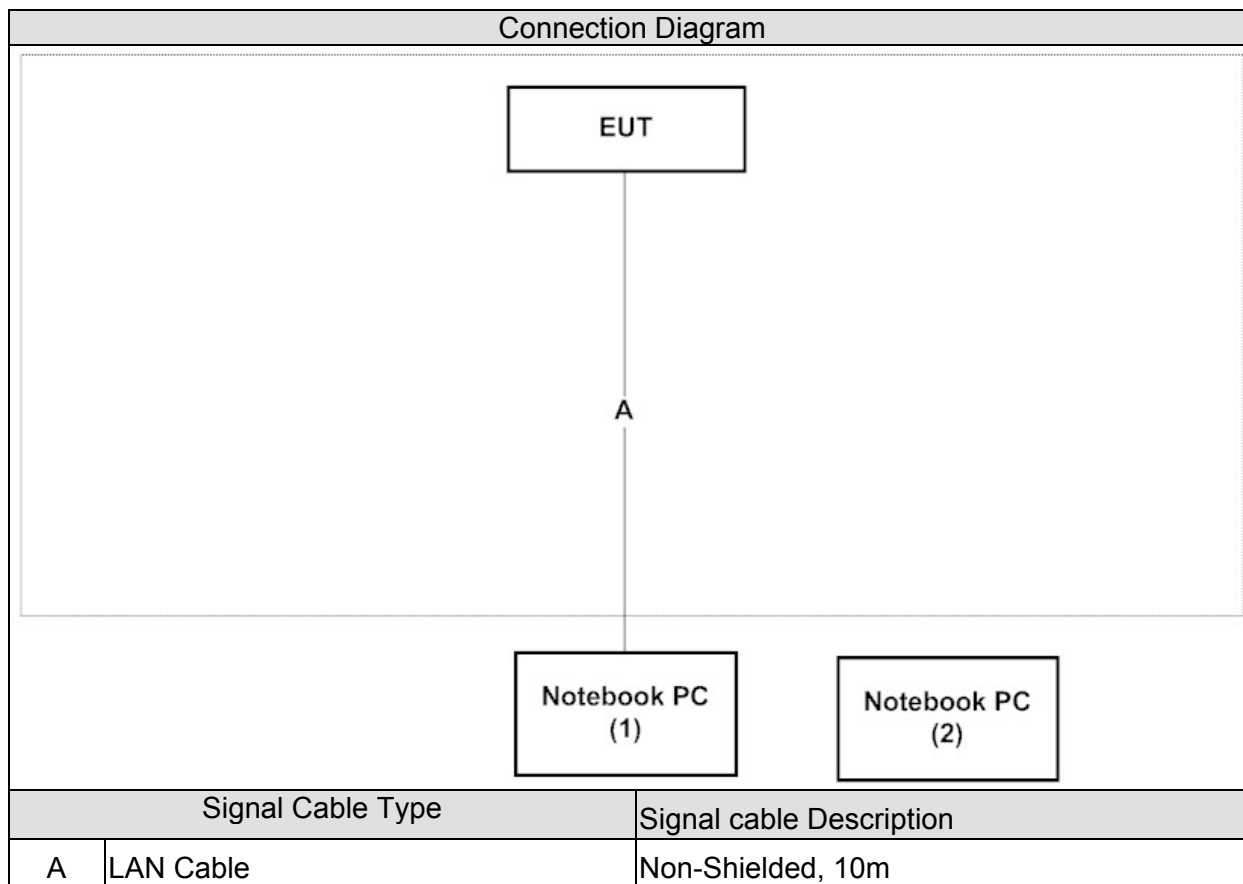

**1.6. EUT Exercise Software**

1	Setup the EUT and simulators as shown on 1.5.
2	Turn on the power of all equipment.
3	Boot the Notebook PC from Hard Disk.
4	Data will communicate by connecting to LAN port and wireless of Notebook PC.
5	The computer's monitor will show the transmitting and receiving characteristics when the communication is success.
6	Repeat the above procedure (4) to (5).

## 1.7. Test Facility

Ambient conditions in the laboratory:

Items	Test Item	Required (IEC 68-1)	Actual
Temperature (°C)	FCC PART 15 C 15.207 Conducted Emission	15 - 35	20
Humidity (%RH)		25 - 75	50
Barometric pressure (mbar)		860 - 1060	950-1000
Temperature (°C)	FCC PART 15 C 15.247 Peak Power Output (DSSS)	15 - 35	25
Humidity (%RH)		25 - 75	46
Barometric pressure (mbar)		860 - 1060	950-1000
Temperature (°C)	FCC PART 15 C 15.247 Radiated Emission (DSSS)	15 - 35	25
Humidity (%RH)		25 - 75	65
Barometric pressure (mbar)		860 - 1060	950-1000
Temperature (°C)	FCC PART 15 C 15.247 RF antenna conducted test (DSSS)	15 - 35	24
Humidity (%RH)		25 - 75	49
Barometric pressure (mbar)		860 - 1060	950-1000
Temperature (°C)	FCC PART 15 C 15.247 Band Edge (DSSS)	15 - 35	25
Humidity (%RH)		25 - 75	48
Barometric pressure (mbar)		860 - 1060	950-1000
Temperature (°C)	FCC PART 15 C 15.247 Occupied Bandwidth (DSSS)	15 - 35	26
Humidity (%RH)		25 - 75	46
Barometric pressure (mbar)		860 - 1060	950-1000
Temperature (°C)	FCC PART 15 C 15.247 Power Density (DSSS)	15 - 35	25
Humidity (%RH)		25 - 75	48
Barometric pressure (mbar)		860 - 1060	950-1000

Site Description: September 27, 2010 File on  
Federal Communications Commission  
Laboratory Division  
7435 Oakland Mills Road  
Columbia, MD 21046  
Registration Number: 365520



Accredited by TAF  
Accreditation Number: 1313  
Effective through: December 27, 2010



Accredited by NVLAP  
NVLAP Lab Code: 200347-0  
Effective through: September 30, 2011



Site Name: Quietek Corporation  
Site Address: No.75-2, 3rd Lin, Wang Ye keng, Yonghxing Tsuen,  
Qionglin Shiang, Hsinchu County 307,  
Taiwan, R.O.C.  
TEL : 886-3-5928858 / FAX : 886-3-5928859  
E-Mail : [service@quietek.com](mailto:service@quietek.com)

2. Conducted Emission

2.1. Test Equipment

The following test equipments are used during the test:

**Conducted Emission / SR2 (Mode 1)**

Instrument	Manufacturer	Model No.	Serial No	Next Cal. Date
Artificial Mains Network	R&S	ENV4200	848411/010	2011/03/14
LISN	R&S	ENV216	100092	2011/09/12
Test Receiver	R&S	ESCS 30	825442/014	2011/09/02

**Conducted Emission / SR3 (Mode 2)**

Instrument	Manufacturer	Model No.	Serial No	Next Cal. Date
LISN	R&S	ENV216	100096	2011/09/20
LISN	R&S	ESH3-Z5	836679/022	2011/05/30
Test Receiver	R&S	ESCS 30	825442/017	2011/02/04

Note: 1. All equipments that need to calibrate are with calibration period of 1 year.

2.2. Test Setup

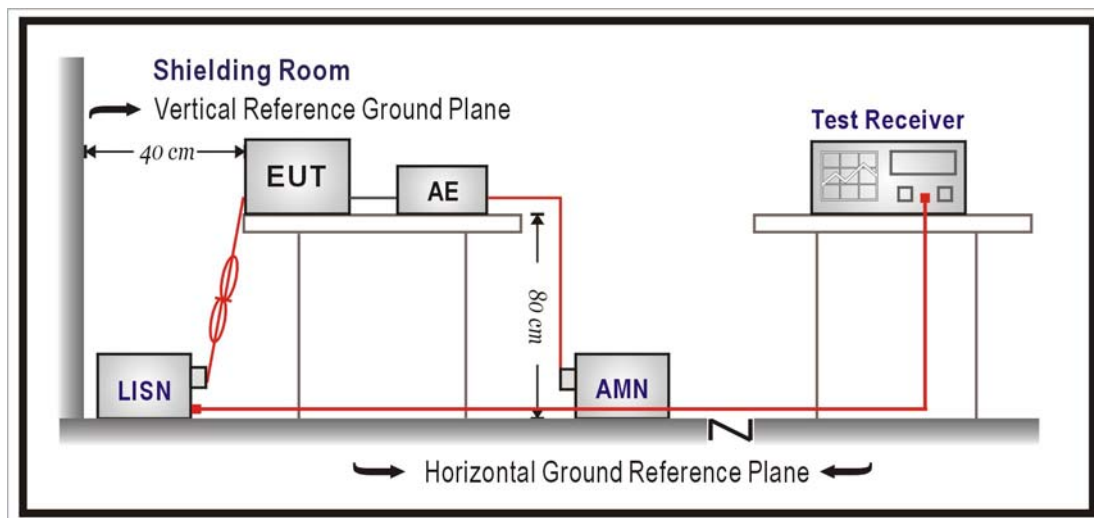

**2.3. Limits**

<b>FCC Part 15 Subpart C Paragraph 15.207 Limits (dBuV)</b>		
Frequency MHz	QP	AV
0.15 - 0.50	66-56	56-46
0.50 - 5.0	56	46
5.0 - 30	60	50

Remarks: In the above table, the tighter limit applies at the band edges.

**2.4. Test Procedure**

The EUT was setup according to ANSI C63.4: 2009 and tested according to DTS test procedure of Oct 2002 KDB558074 for compliance to FCC 47CFR 15.247 requirements. The EUT was placed on a platform of nominal size, 1 m by 1.5 m, raised 80 cm above the conducting ground plane. The vertical conducting plane was located 40 cm to the rear of the EUT. All other surfaces of EUT were at least 80 cm from any other grounded conducting surface. The EUT and simulators are connected to the main power through a line impedance stabilization network (LISN). The LISN provides a 50 ohm /50uH coupling impedance for the measuring equipment. The peripheral devices are also connected to the main power through a LISN. (Please refer to the block diagram of the test setup and photographs.) Each current-carrying conductor of the EUT power cord, except the ground (safety) conductor, was individually connected through a LISN to the input power source. The excess length of the power cord between the EUT and the LISN receptacle were folded back and forth at the center of the lead to form a bundle not exceeding 40 cm in length. Conducted emissions were investigated over the frequency range from 0.15MHz to 30MHz using a receiver bandwidth of 9 kHz.

**2.5. Test Specification**

According to FCC Part 15 Subpart C Paragraph 15.207: 2009

**2.6. Uncertainty**

The measurement uncertainty is defined as  $\pm 2.26$  dB.

2.7. Test Result

Site : SR2	Time : 2010/10/14 - 15:48
Limit : CISPR_B_00M_QP	Margin : 10
Probe : SR2-LISN(16A) - Line1	Power : AC 120V/60Hz
EUT : Wireless N Day/Night Home Network Camera	Note : Mode 1: Transmit (Adapter: AMS1-0501200FU)-IEEE 802.11n(40M)-2437MHz

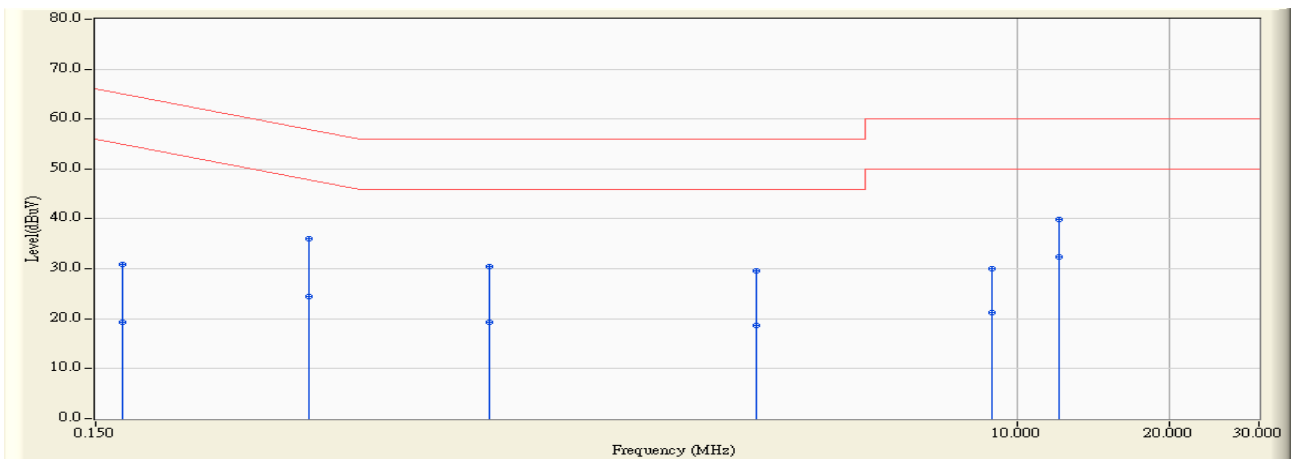

	Frequency (MHz)	Correct Factor (dB)	Reading Level (dBuV)	Measure Level (dBuV)	Margin (dB)	Limit (dBuV)	Detector Type
1	0.170	9.778	21.080	30.858	-34.126	64.983	QUASPEAK
2	0.170	9.778	9.610	19.388	-35.596	54.983	AVERAGE
3	0.396	9.830	26.160	35.990	-21.945	57.935	QUASPEAK
4	0.396	9.830	14.520	24.350	-23.585	47.935	AVERAGE
5	0.900	9.662	20.880	30.542	-25.458	56.000	QUASPEAK
6	0.900	9.662	9.550	19.212	-26.788	46.000	AVERAGE
7	3.048	9.820	19.700	29.520	-26.480	56.000	QUASPEAK
8	3.048	9.820	8.850	18.670	-27.330	46.000	AVERAGE
9	8.884	9.949	20.110	30.058	-29.942	60.000	QUASPEAK
10	8.884	9.949	11.240	21.188	-28.812	50.000	AVERAGE
11	12.037	10.069	29.880	39.949	-20.051	60.000	QUASPEAK
12	* 12.037	10.069	22.210	32.279	-17.721	50.000	AVERAGE

Note:

1. All Reading Levels are Quasi-Peak and average value.
2. " \* ", means this data is the worst emission level.
3. Measurement Level = Reading Level + Correct Factor.

Site : SR2	Time : 2010/10/14 - 15:51
Limit : CISPR_B_00M_QP	Margin : 10
Probe : SR2-LISN(16A) - Line2	Power : AC 120V/60Hz
EUT : Wireless N Day/Night Home Network Camera	Note : Mode 1: Transmit (Adapter: AMS1-0501200FU)-IEEE 802.11n(40M)-2437MHz

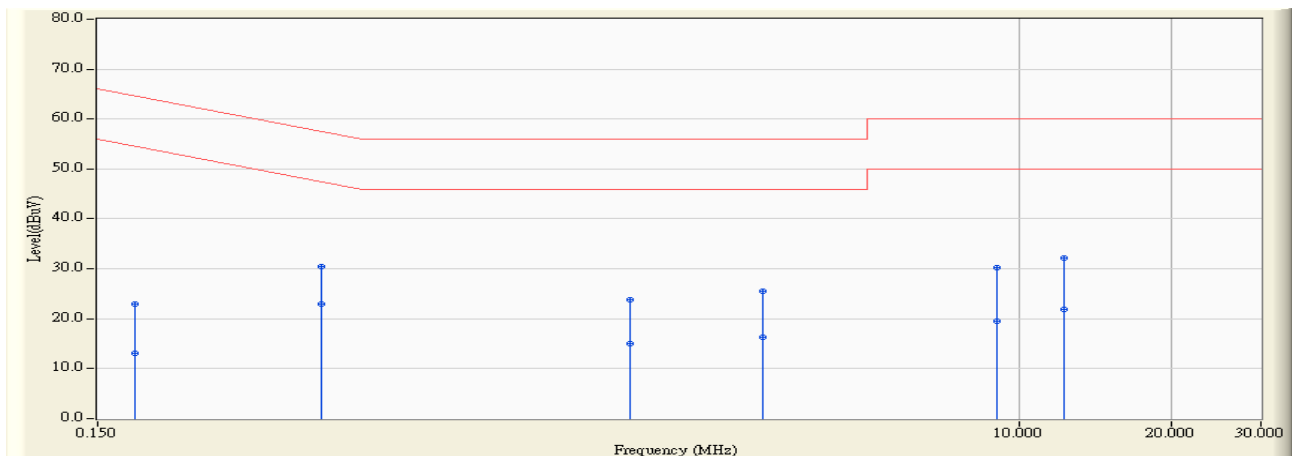

	Frequency (MHz)	Correct Factor (dB)	Reading Level (dBuV)	Measure Level (dBuV)	Margin (dB)	Limit (dBuV)	Detector Type
1	0.177	9.767	13.230	22.997	-41.612	64.609	QUASPEAK
2	0.177	9.767	3.410	13.177	-41.432	54.609	AVERAGE
3	0.416	9.838	20.610	30.448	-27.087	57.535	QUASPEAK
4	*	9.838	13.090	22.928	-24.607	47.535	AVERAGE
5	1.693	9.745	13.980	23.725	-32.275	56.000	QUASPEAK
6	1.693	9.745	5.210	14.955	-31.045	46.000	AVERAGE
7	3.107	9.821	15.610	25.431	-30.569	56.000	QUASPEAK
8	3.107	9.821	6.560	16.381	-29.619	46.000	AVERAGE
9	9.017	9.977	20.370	30.347	-29.653	60.000	QUASPEAK
10	9.017	9.977	9.640	19.617	-30.383	50.000	AVERAGE
11	12.255	10.127	22.130	32.257	-27.743	60.000	QUASPEAK
12	12.255	10.127	11.650	21.777	-28.223	50.000	AVERAGE

**Note:**

1. All Reading Levels are Quasi-Peak and average value.
2. " \* ", means this data is the worst emission level.
3. Measurement Level = Reading Level + Correct Factor.



Site : SR3	Time : 2010/11/15 - 14:22
Limit : CISPR_B_00M_QP	Margin : 10
Probe : SR3_LISN(16A) - Line1	Power : AC 120V / 60Hz
EUT : Wireless N Day/Night Home Network Camera	Note : Mode 2: Transmit (Adapter: MU06-9050120-A1)-IEEE 802.11n(40M)-2437MHz

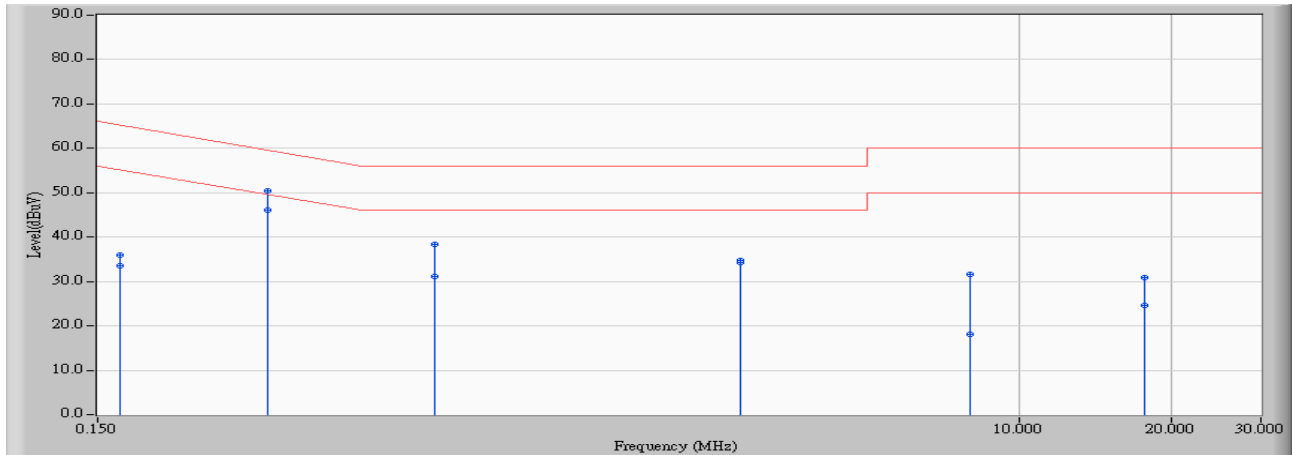

	Frequency (MHz)	Correct Factor (dB)	Reading Level (dBuV)	Measure Level (dBuV)	Margin (dB)	Limit (dBuV)	Detector Type
1	0.166	9.667	26.197	35.864	-29.294	65.158	QUASPEAK
2	0.166	9.667	23.956	33.623	-21.536	55.158	AVERAGE
3	0.326	9.654	40.882	50.535	-9.017	59.552	QUASPEAK
4	* 0.326	9.654	36.352	46.005	-3.547	49.552	AVERAGE
5	0.698	9.807	28.589	38.396	-17.604	56.000	QUASPEAK
6	0.698	9.807	21.238	31.045	-14.955	46.000	AVERAGE
7	2.810	9.992	24.810	34.802	-21.198	56.000	QUASPEAK
8	2.810	9.992	24.348	34.339	-11.661	46.000	AVERAGE
9	8.002	10.120	21.450	31.570	-28.430	60.000	QUASPEAK
10	8.002	10.120	7.937	18.057	-31.943	50.000	AVERAGE
11	17.694	10.250	20.664	30.914	-29.086	60.000	QUASPEAK
12	17.694	10.250	14.452	24.702	-25.298	50.000	AVERAGE

**Note:**

1. All Reading Levels are Quasi-Peak and average value.
2. " \* ", means this data is the worst emission level.
3. Measurement Level = Reading Level + Correct Factor.

Site : SR3	Time : 2010/11/15 - 14:27
Limit : CISPR_B_00M_QP	Margin : 10
Probe : SR3_LISN(16A) - Line2	Power : AC 120V / 60Hz
EUT : Wireless N Day/Night Home Network Camera	Note : Mode 2: Transmit (Adapter: MU06-9050120-A1)- _IEEE 802.11n(40M)-2437MHz

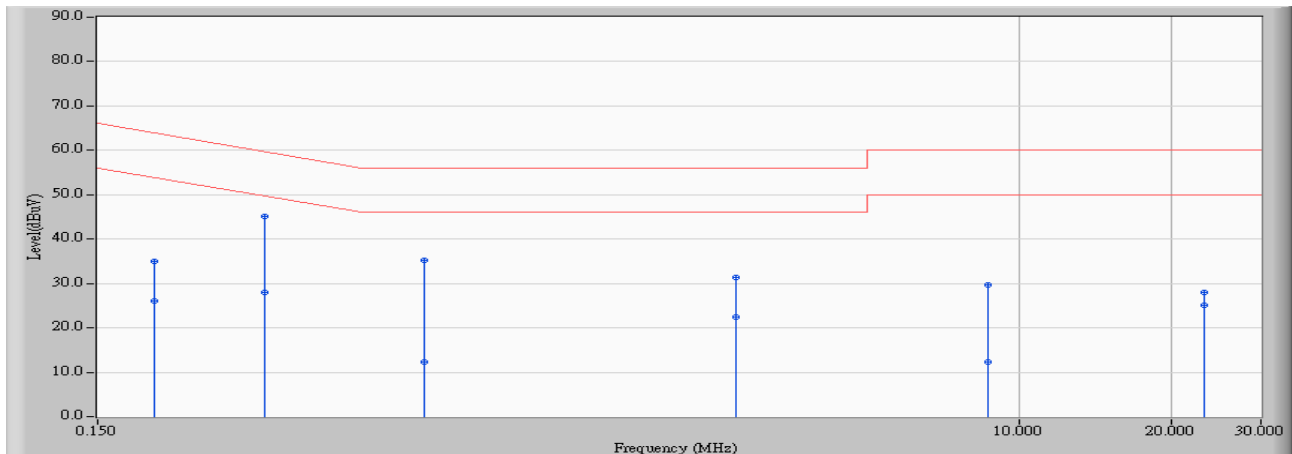

	Frequency (MHz)	Correct Factor (dB)	Reading Level (dBuV)	Measure Level (dBuV)	Margin (dB)	Limit (dBuV)	Detector Type
1	0.194	9.662	25.290	34.952	-28.912	63.864	QUASPEAK
2	0.194	9.662	16.353	26.015	-27.849	53.864	AVERAGE
3	* 0.322	9.654	35.512	45.166	-14.489	59.655	QUASPEAK
4	0.322	9.654	18.289	27.943	-21.713	49.655	AVERAGE
5	0.666	9.790	25.338	35.129	-20.871	56.000	QUASPEAK
6	0.666	9.790	2.550	12.341	-33.659	46.000	AVERAGE
7	2.738	9.991	21.381	31.371	-24.629	56.000	QUASPEAK
8	2.738	9.991	12.389	22.379	-23.621	46.000	AVERAGE
9	8.638	10.160	19.522	29.681	-30.319	60.000	QUASPEAK
10	8.638	10.160	2.175	12.335	-37.665	50.000	AVERAGE
11	23.130	10.563	17.314	27.877	-32.123	60.000	QUASPEAK
12	23.130	10.563	14.493	25.056	-24.944	50.000	AVERAGE

**Note:**

1. All Reading Levels are Quasi-Peak and average value.
2. " \* ", means this data is the worst emission level.
3. Measurement Level = Reading Level + Correct Factor.

**3. Peak Power Output**

**3.1. Test Equipment**

The following test equipments are used during the test:

**Peak Power / SR7**

Instrument	Manufacturer	Model No.	Serial No	Next Cal. Date
Power Meter	Agilent	N1911A	MY45101353	2011/01/17
Power Sensor	Agilent	N1921A	MY45241670	2011/01/17

Note: 1. All equipments that need to calibrate are with calibration period of 1 year.

**3.2. Test Setup**

IEEE 802.11 b / g / n ( 20M / 40M ) MODE

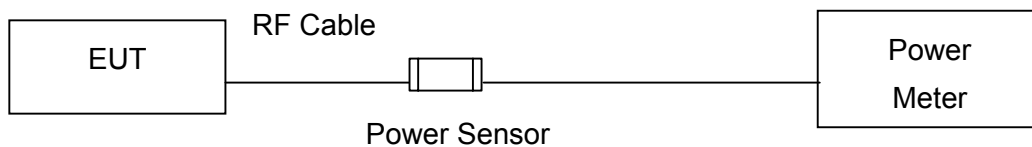

**3.3. Test procedures**

The EUT was tested according to DTS test procedure of Oct 2002 KDB558074 for compliance to FCC 47CFR 15.247 requirements.

**3.4. Limits**

The maximum peak power shall be less 1 Watt.

**3.5. Test Specification**

According to FCC Part 15 Subpart C Paragraph 15.247: 2009

**3.6. Uncertainty**

The measurement uncertainty is defined as  $\pm 1.27$  dB.

**3.7. Test Result**

Product	Wireless N Day/Night Home Network Camera		
Test Item	Peak Power Output		
Test Mode	Transmit		
Date of Test	2010/10/15	Test Site	SR7

IEEE 802.11b				
Channel No.	Frequency (MHz)	Measure Level (dBm)	Limit (dBm)	Result
1	2412	23.07	1Watt= 30 dBm	Pass
6	2437	23.06	1Watt= 30 dBm	Pass
11	2462	22.53	1Watt= 30 dBm	Pass

The worst emission of data rate is 1 Mbps.

Peak Power Output Value (dBm)						
Channel No.	Frequency (MHz)	Data Rate				Required Limit
		1	2	5.5	11	
1	2412.00	23.07	22.55	23.04	23.05	1Watt= 30 dBm
6	2437.00	23.06	22.95	22.94	23.03	1Watt= 30 dBm
11	2462.00	22.53	22.15	22.18	22.21	1Watt= 30 dBm

Note: Measure Level =Reading value + cable loss

Product	Wireless N Day/Night Home Network Camera		
Test Item	Peak Power Output		
Test Mode	Transmit		
Date of Test	2010/10/15	Test Site	SR7

IEEE 802.11g				
Channel No.	Frequency (MHz)	Measure Level (dBm)	Limit (dBm)	Result
1	2412	25.62	1Watt= 30 dBm	Pass
6	2437	25.50	1Watt= 30 dBm	Pass
11	2462	25.46	1Watt= 30 dBm	Pass

The worst emission of data rate is 6 Mbps.

Peak Power Output Value(dBm)										
Channel No.	Frequency (MHz)	Data Rate (Mbps)								Required Limit
		6	9	12	18	24	36	48	54	
1	2412	25.62	25.41	25.43	25.48	25.48	25.45	25.13	25.60	1Watt= 30 dBm
6	2437	25.50	25.32	25.35	25.37	25.39	25.35	25.02	25.48	1Watt= 30 dBm
11	2462	25.46	25.28	25.31	25.37	25.38	25.39	24.98	25.11	1Watt= 30 dBm

Note: Measure Level =Reading value + cable loss

Product	Wireless N Day/Night Home Network Camera		
Test Item	Peak Power Output		
Test Mode	Transmit		
Date of Test	2010/10/15	Test Site	SR7

IEEE 802.11n (20MHz)				
Channel No.	Frequency (MHz)	Measure Level (dBm)	Limit (dBm)	Result
1	2412	22.72	1Watt= 30 dBm	Pass
6	2437	22.43	1Watt= 30 dBm	Pass
11	2462	21.81	1Watt= 30 dBm	Pass

The worst emission of data rate is 6.5 Mbps.

Peak Power Output (dBm)										
MCS Index		0	1	2	3	4	5	6	7	Required Limit
Channel No	Frequency (MHz)	Data Rate								
		6.5	13	19.5	26	39	52	58.8	65	
1	2412	22.72	22.68	22.19	22.60	22.63	22.52	22.23	22.58	30dBm
6	2437	22.43	22.40	21.90	22.31	22.42	21.22	21.91	22.36	30dBm
11	2462	21.81	21.79	21.30	21.70	21.77	21.61	21.42	21.63	30dBm

Note: Measure Level =Reading value + cable loss

Product	Wireless N Day/Night Home Network Camera		
Test Item	Peak Power Output		
Test Mode	Transmit		
Date of Test	2010/10/15	Test Site	SR7

IEEE 802.11n (40MHz)				
Channel No.	Frequency (MHz)	Measure Level (dBm)	Limit (dBm)	Result
3	2422	25.72	1Watt= 30 dBm	Pass
6	2437	25.02	1Watt= 30 dBm	Pass
9	2452	25.44	1Watt= 30 dBm	Pass

The worst emission of data rate is 13.5Mbps

Peak Power Output (dBm)										
MCS Index		0	1	2	3	4	5	6	7	Required Limit
Channel No	Frequency (MHz)	Data Rate								
		13.5	27	40.5	54	81	108	121.5	135	
3	2422	25.72	24.35	25.67	25.19	25.57	25.39	25.31	25.07	30dBm
6	2437	25.02	23.65	24.97	24.51	24.89	24.70	24.65	25.47	30dBm
9	2452	25.44	24.05	25.38	24.90	25.29	25.12	25.09	24.38	30dBm

Note: Measure Level =Reading value + cable loss

4. Radiated Emission

4.1. Test Equipment

The following test equipments are used during the test:

Radiated Emission / CB1

Instrument	Manufacturer	Model No.	Serial No	Next Cal. Date
Bilog Antenna	SCHAFFNER	CBL6112B	2895	2011/08/14
Horn Antenna	Schwarzback	BBHA 9120D	743	2011/03/14
Pre-Amplifier	MITEQ	AMF-4D-005180-24-10P	888003	2010/12/03
Pre-Amplifier	QuieTek	AP-025C	CHM-0706049	2011/03/25
Spectrum Analyzer	Agilent	E4440A	MY46187335	2011/01/14
Coaxial Cable	Huber+Suhner AG	Sucoflex 102	25623/2	2011/04/07

Note: 1. All equipments that need to calibrate are with calibration period of 1 year.

4.2. Test Setup

Under 1GHz Test Setup:

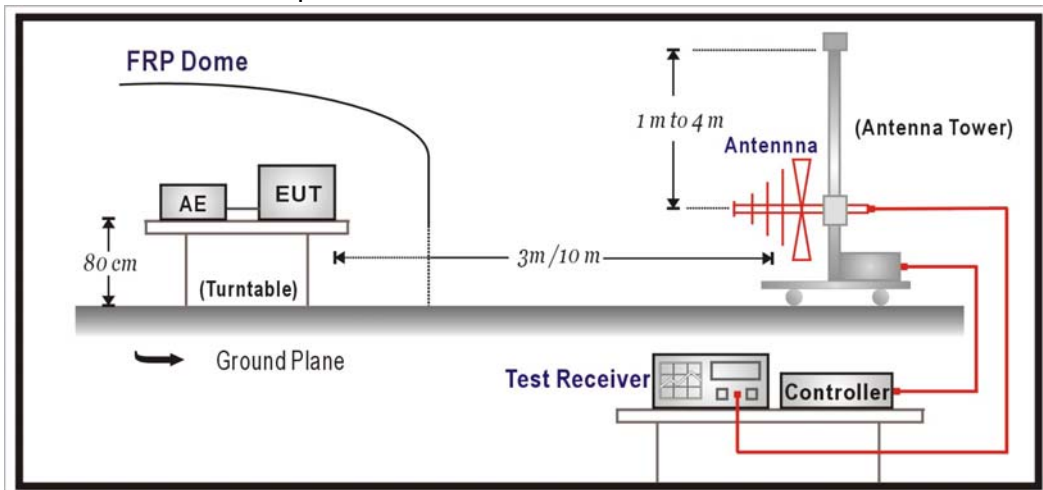

Above 1GHz Test Setup:

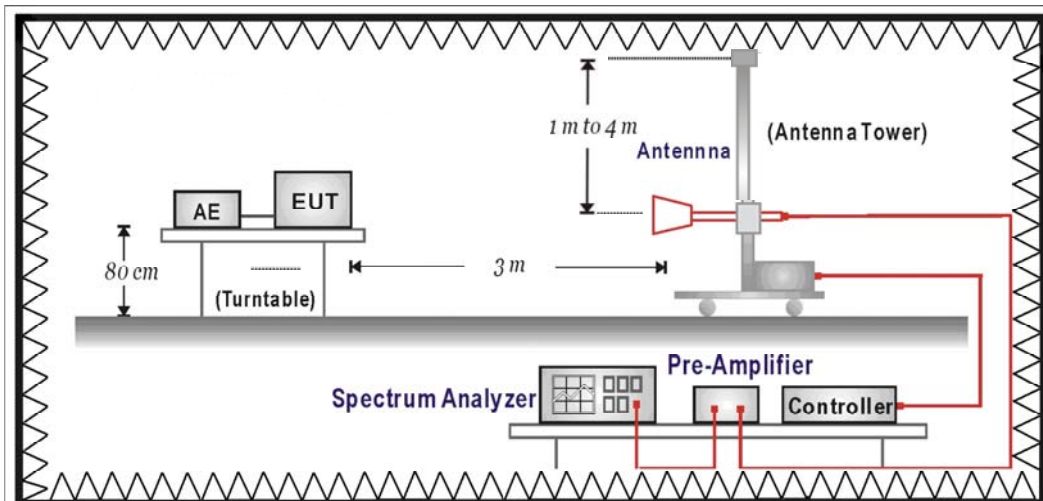



**4.3. Limits**

Emissions radiated outside of the specified frequency bands, except for harmonics, shall be attenuated by at least 20dB below the level of the fundamental or to the general radiated emission limits in paragraph 15.209, whichever is the lesser attenuation.

<b>FCC Part 15 Subpart C Paragraph 15.209 Limits</b>		
Frequency MHz	dBuV/m	dBuV/m
30-88	100	40
88-216	150	43.5
216-960	200	46
Above 960	500	54

Remarks: E field strength (dBuV/m) = 20 log E field strength (uV/m)

**4.4. Test Procedure**

The EUT was setup according to ANSI C63.4: 2009 and tested according to DTS test procedure of Oct 2002 KDB558074 for compliance to FCC 47CFR 15.247 requirements. The EUT and its simulators are placed on a turn table which is 0.8 meter above ground. The turn table can rotate 360 degrees to determine the position of the maximum emission level. The antenna can move up and down between 1 meter and 4 meters to find out the maximum emission level.

Both horizontal and vertical polarization of the antenna are set on measurement. In order to find the maximum emission, all of the interface cables must be manipulated according to ANSI C63.4: 2009 on radiated measurement.

On any frequency or frequencies below or equal to 1000 MHz, the limits shown are based on measuring equipment employing a quasi-peak detector function and on any frequency or frequencies above 1000 MHz the radiated limits shown are based upon the use of measurement instrumentation employing an average detector function. When average radiated emission measurement are included emission measurement below 1000 MHz, there also is a limit on the radio frequency emissions, as measured using instrumentation with a peak detector function, corresponding to 20 dB above the maximum permitted average limit. The bandwidth below 1GHz setting on the field strength meter is 120 kHz and above 1GHz is 1MHz.

**4.5. Test Specification**

According to FCC Part 15 Subpart C Paragraph 15.247: 2009

**4.6. Uncertainty**

The measurement uncertainty

30MHz~1GHz as ±3.43dB

1GHz~26.5Ghz as ±3.65dB

4.7. Test Result

30MHz-1GHz Spurious

Site : CB1	Time : 2010/10/20 - 09:05
Limit : FCC_CLASS_B_03M_QP	Margin : 6
Probe : FCC_30-1G - HORIZONTAL	Power : AC 120V/60Hz
EUT : Wireless N Day/Night Home Network Camera	Note : Mode 1: Transmit (Adapter: AMS1-0501200FU) -802.11b -2437MHz

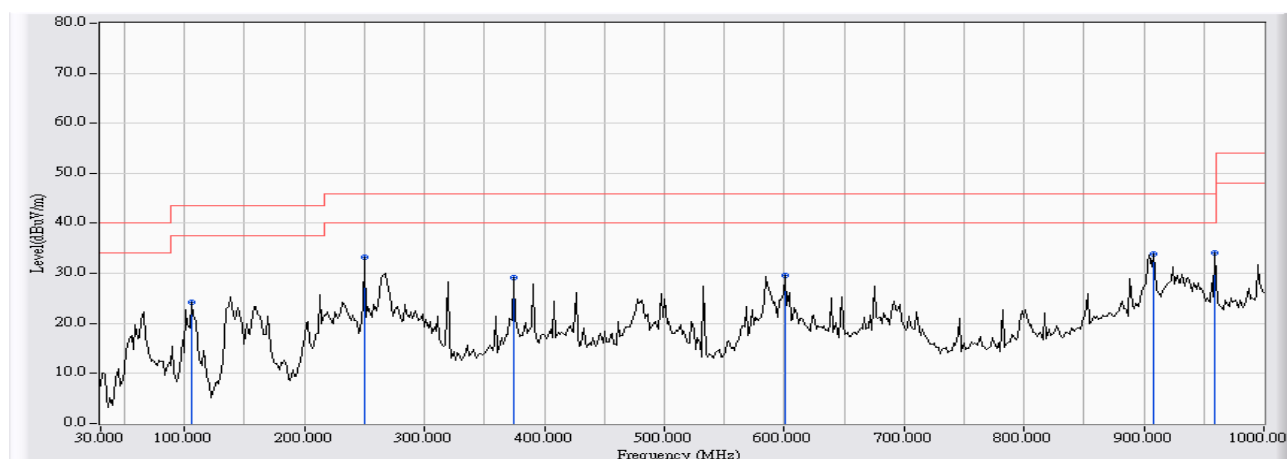

	Frequency (MHz)	Correct Factor (dB)	Reading Level (dBuV)	Measure Level (dBuV/m)	Margin (dB)	Limit (dBuV/m)	Detector Type
1	105.983	-15.660	39.950	24.290	-19.210	43.500	Quasi-Peak
2	249.867	-13.345	46.678	33.333	-12.667	46.000	Quasi-Peak
3	374.350	-11.196	40.285	29.089	-16.911	46.000	Quasi-Peak
4	600.683	-2.795	32.418	29.623	-16.377	46.000	Quasi-Peak
5	907.850	-1.454	35.427	33.973	-12.027	46.000	Quasi-Peak
6	* 959.583	1.179	32.891	34.070	-11.930	46.000	Quasi-Peak

Note:

1. All Reading Levels are Quasi-Peak value.
2. “ \* ”, means this data is the worst emission level.
3. Measurement Level = Reading Level + Correct Factor.

Site : CB1	Time : 2010/10/20 - 09:25
Limit : FCC_CLASS_B_03M_QP	Margin : 6
Probe : FCC_30-1G - VERTICAL	Power : AC 120V/60Hz
EUT : Wireless N Day/Night Home Network Camera	Note : Mode 1: Transmit (Adapter: AMS1-0501200FU) -802.11b -2437MHz

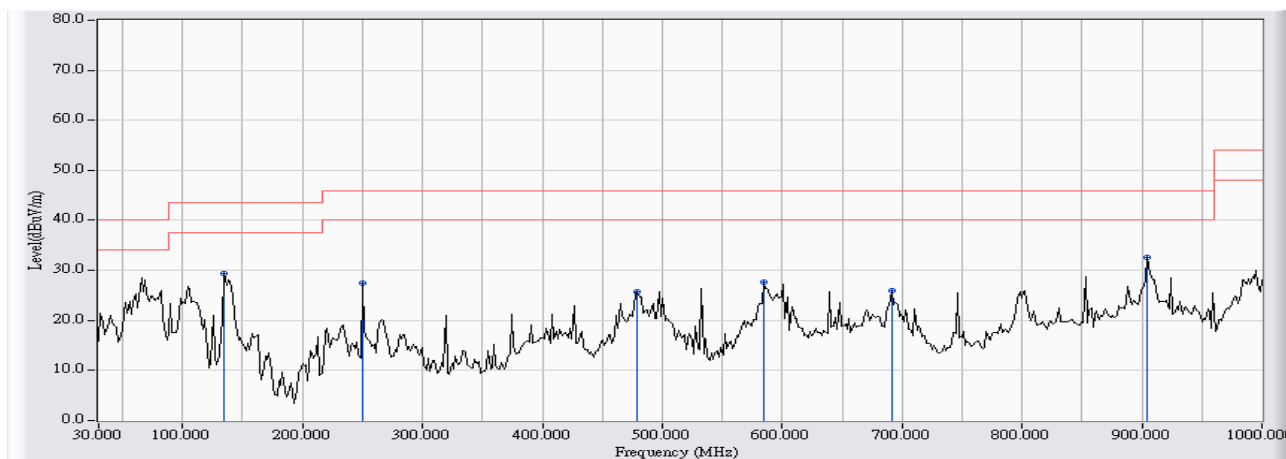

	Frequency (MHz)	Correct Factor (dB)	Reading Level (dBuV)	Measure Level (dBuV/m)	Margin (dB)	Limit (dBuV/m)	Detector Type
1	135.083	-11.868	41.296	29.428	-14.072	43.500	Quasi-Peak
2	249.867	-14.145	41.621	27.476	-18.524	46.000	Quasi-Peak
3	479.433	-4.781	30.484	25.703	-20.297	46.000	Quasi-Peak
4	584.517	-6.303	33.867	27.563	-18.437	46.000	Quasi-Peak
5	691.217	-7.076	32.999	25.923	-20.077	46.000	Quasi-Peak
6	* 904.617	-3.344	35.939	32.595	-13.405	46.000	Quasi-Peak

**Note:**

1. All Reading Levels are Quasi-Peak value.
2. “ \* ”, means this data is the worst emission level.
3. Measurement Level = Reading Level + Correct Factor.

Site : CB1	Time : 2010/10/20 - 09:33
Limit : FCC_CLASS_B_03M_QP	Margin : 6
Probe : FCC_30-1G - HORIZONTAL	Power : AC 120V/60Hz
EUT : Wireless N Day/Night Home Network Camera	Note : Mode 1: Transmit (Adapter: AMS1-0501200FU) -802.11g -2437MHz

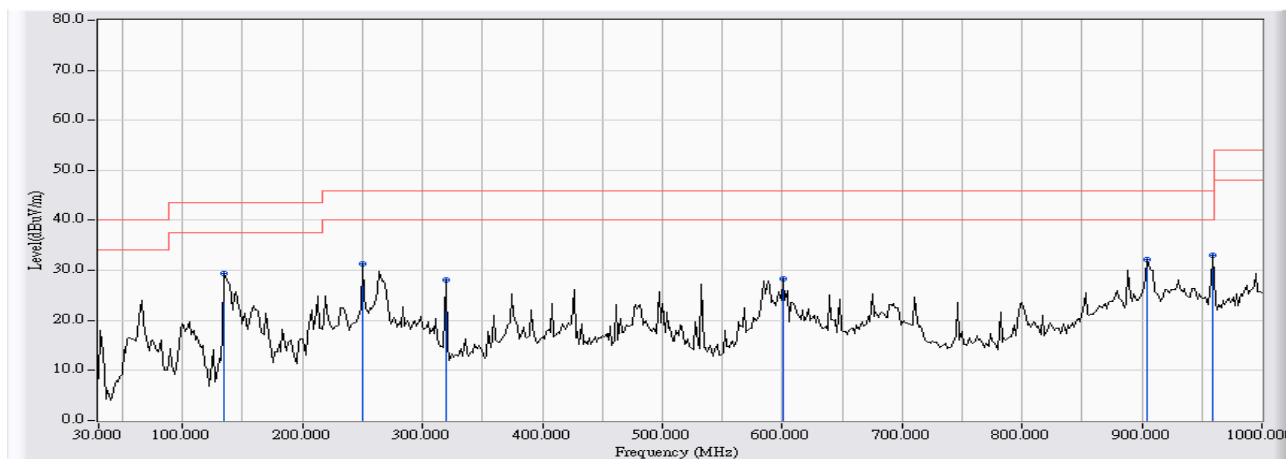

	Frequency (MHz)	Correct Factor (dB)	Reading Level (dBuV)	Measure Level (dBuV/m)	Margin (dB)	Limit (dBuV/m)	Detector Type
1	135.083	-11.868	41.343	29.475	-14.025	43.500	Quasi-Peak
2	249.867	-14.145	45.554	31.409	-14.591	46.000	Quasi-Peak
3	319.383	-13.395	41.405	28.010	-17.990	46.000	Quasi-Peak
4	600.683	-3.087	31.438	28.351	-17.649	46.000	Quasi-Peak
5	904.617	-3.344	35.442	32.098	-13.902	46.000	Quasi-Peak
6	* 959.583	-5.055	38.118	33.063	-12.937	46.000	Quasi-Peak

**Note:**

1. All Reading Levels are Quasi-Peak value.
2. “ \* ”, means this data is the worst emission level.
3. Measurement Level = Reading Level + Correct Factor.

Site : CB1	Time : 2010/10/20 - 09:36
Limit : FCC_CLASS_B_03M_QP	Margin : 6
Probe : FCC_30-1G - VERTICAL	Power : AC 120V/60Hz
EUT : Wireless N Day/Night Home Network Camera	Note : Mode 1: Transmit (Adapter: AMS1-0501200FU) -802.11g -2437MHz

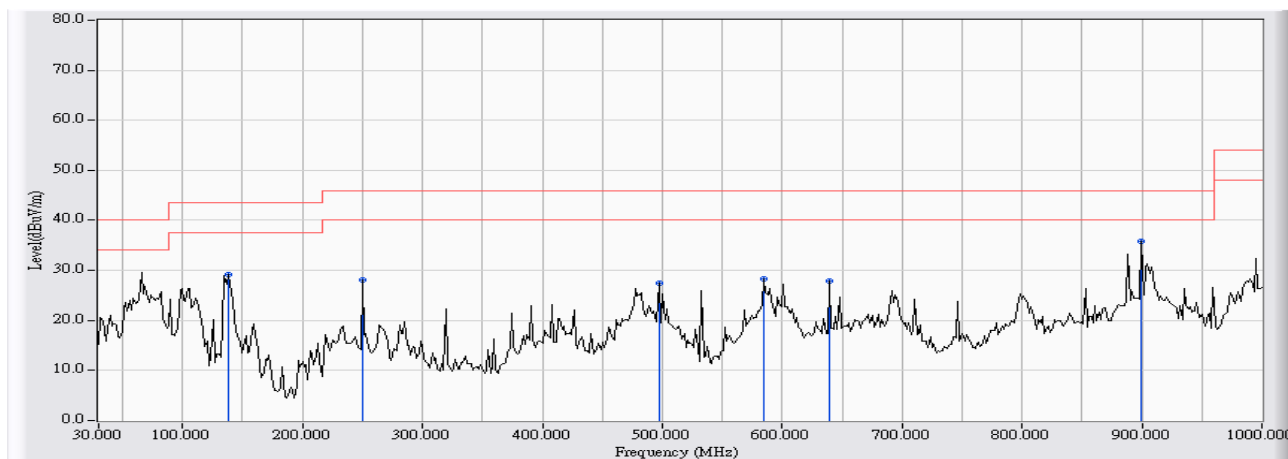

	Frequency (MHz)	Correct Factor (dB)	Reading Level (dBuV)	Measure Level (dBuV/m)	Margin (dB)	Limit (dBuV/m)	Detector Type
1	138.317	-12.428	41.607	29.180	-14.320	43.500	Quasi-Peak
2	249.867	-14.145	42.328	28.183	-17.817	46.000	Quasi-Peak
3	497.217	-6.414	33.836	27.422	-18.578	46.000	Quasi-Peak
4	584.517	-6.303	34.701	28.397	-17.603	46.000	Quasi-Peak
5	639.483	-3.705	31.645	27.940	-18.060	46.000	Quasi-Peak
6	* 899.767	-3.980	39.745	35.765	-10.235	46.000	Quasi-Peak

**Note:**

1. All Reading Levels are Quasi-Peak value.
2. “ \* ”, means this data is the worst emission level.
3. Measurement Level = Reading Level + Correct Factor.

Site : CB1	Time : 2010/10/20 - 09:42
Limit : FCC_CLASS_B_03M_QP	Margin : 6
Probe : FCC_30-1G - HORIZONTAL	Power : AC 120V/60Hz
EUT : Wireless N Day/Night Home Network Camera	Note : Mode 1: Transmit (Adapter: AMS1-0501200FU) -802.11n(20M) -2437MHz

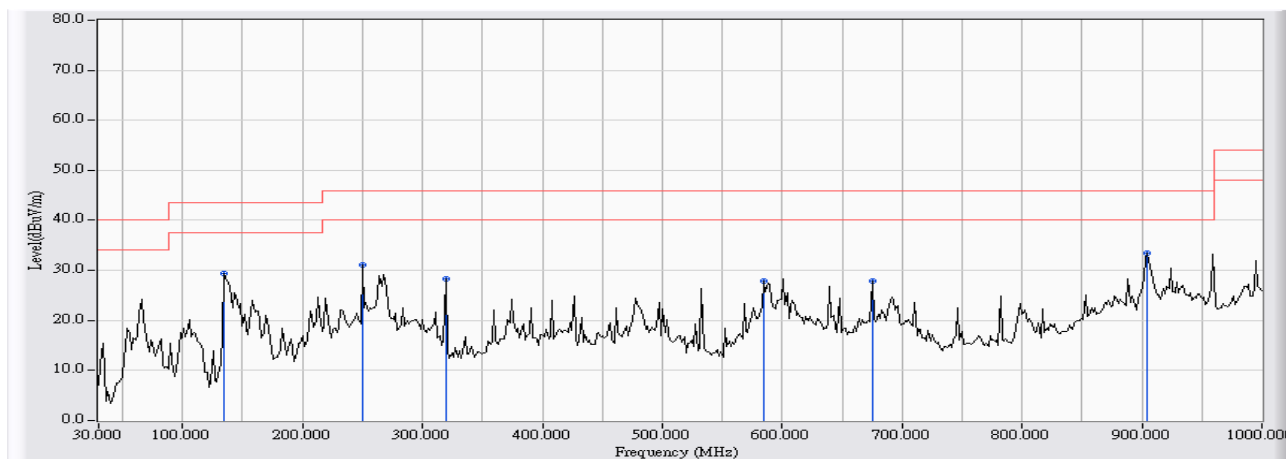

	Frequency (MHz)	Correct Factor (dB)	Reading Level (dBuV)	Measure Level (dBuV/m)	Margin (dB)	Limit (dBuV/m)	Detector Type
1	135.083	-15.744	45.086	29.342	-14.158	43.500	Quasi-Peak
2	249.867	-13.345	44.382	31.037	-14.963	46.000	Quasi-Peak
3	319.383	-10.873	39.261	28.388	-17.612	46.000	Quasi-Peak
4	584.517	-5.455	33.292	27.836	-18.164	46.000	Quasi-Peak
5	675.050	-3.408	31.351	27.944	-18.056	46.000	Quasi-Peak
6	* 904.617	-1.247	34.643	33.396	-12.604	46.000	Quasi-Peak

**Note:**

1. All Reading Levels are Quasi-Peak value.
2. “ \* ”, means this data is the worst emission level.
3. Measurement Level = Reading Level + Correct Factor.

Site : CB1	Time : 2010/10/20 - 09:45
Limit : FCC_CLASS_B_03M_QP	Margin : 6
Probe : FCC_30-1G - VERTICAL	Power : AC 120V/60Hz
EUT : Wireless N Day/Night Home Network Camera	Note : Mode 1: Transmit (Adapter: AMS1-0501200FU) -802.11n(20M) -2437MHz

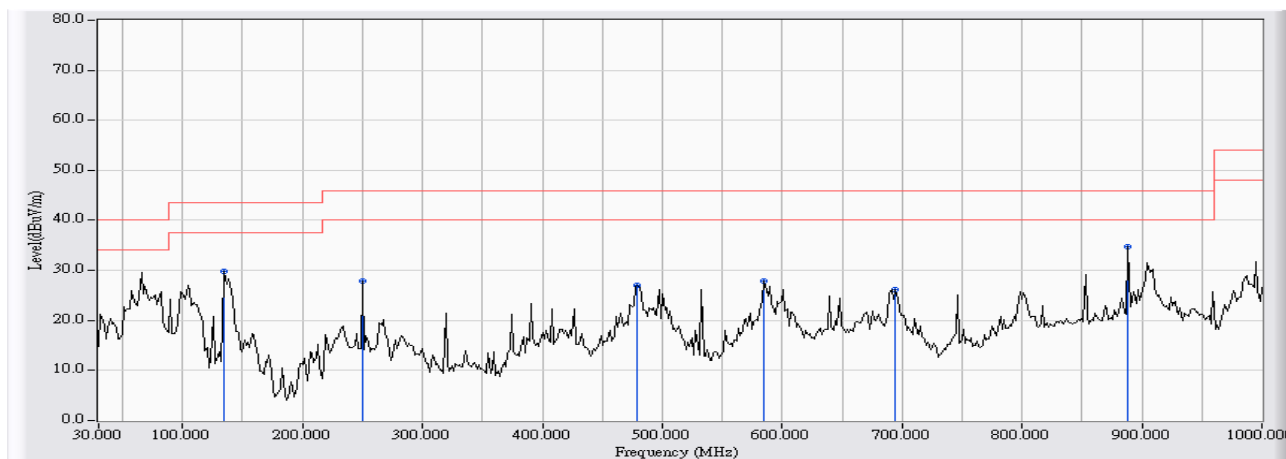

	Frequency (MHz)	Correct Factor (dB)	Reading Level (dBuV)	Measure Level (dBuV/m)	Margin (dB)	Limit (dBuV/m)	Detector Type
1	135.083	-11.868	41.579	29.711	-13.789	43.500	Quasi-Peak
2	249.867	-14.145	41.925	27.780	-18.220	46.000	Quasi-Peak
3	479.433	-4.781	31.786	27.005	-18.995	46.000	Quasi-Peak
4	584.517	-6.303	34.246	27.942	-18.058	46.000	Quasi-Peak
5	694.450	-7.116	33.297	26.182	-19.818	46.000	Quasi-Peak
6	* 888.450	-3.113	37.779	34.666	-11.334	46.000	Quasi-Peak

**Note:**

1. All Reading Levels are Quasi-Peak value.
2. “ \* ”, means this data is the worst emission level.
3. Measurement Level = Reading Level + Correct Factor.

Site : CB1	Time : 2010/10/20 - 09:51
Limit : FCC_CLASS_B_03M_QP	Margin : 6
Probe : FCC_30-1G - HORIZONTAL	Power : AC 120V/60Hz
EUT : Wireless N Day/Night Home Network Camera	Note : Mode 1: Transmit (Adapter: AMS1-0501200FU) -802.11n(40M) -2437MHz

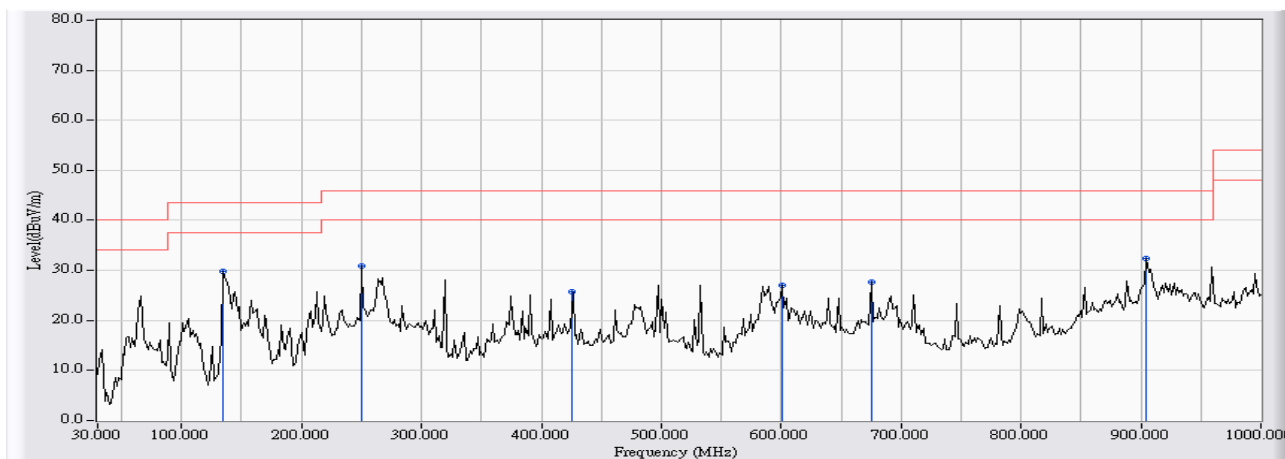

		Frequency (MHz)	Correct Factor (dB)	Reading Level (dBuV)	Measure Level (dBuV/m)	Margin (dB)	Limit (dBuV/m)	Detector Type
1	*	135.083	-15.744	45.634	29.890	-13.610	43.500	Quasi-Peak
2		249.867	-13.345	44.317	30.972	-15.028	46.000	Quasi-Peak
3		426.083	-5.040	30.759	25.719	-20.281	46.000	Quasi-Peak
4		600.683	-2.795	29.807	27.012	-18.988	46.000	Quasi-Peak
5		675.050	-3.408	31.075	27.668	-18.332	46.000	Quasi-Peak
6		904.617	-1.247	33.618	32.371	-13.629	46.000	Quasi-Peak

**Note:**

1. All Reading Levels are Quasi-Peak value.
2. “ \* ”, means this data is the worst emission level.
3. Measurement Level = Reading Level + Correct Factor.



Site : CB1	Time : 2010/10/20 - 09:55
Limit : FCC_CLASS_B_03M_QP	Margin : 6
Probe : FCC_30-1G - VERTICAL	Power : AC 120V/60Hz
EUT : Wireless N Day/Night Home Network Camera	Note : Mode 1: Transmit (Adapter: AMS1-0501200FU) -802.11n(40M) -2437MHz

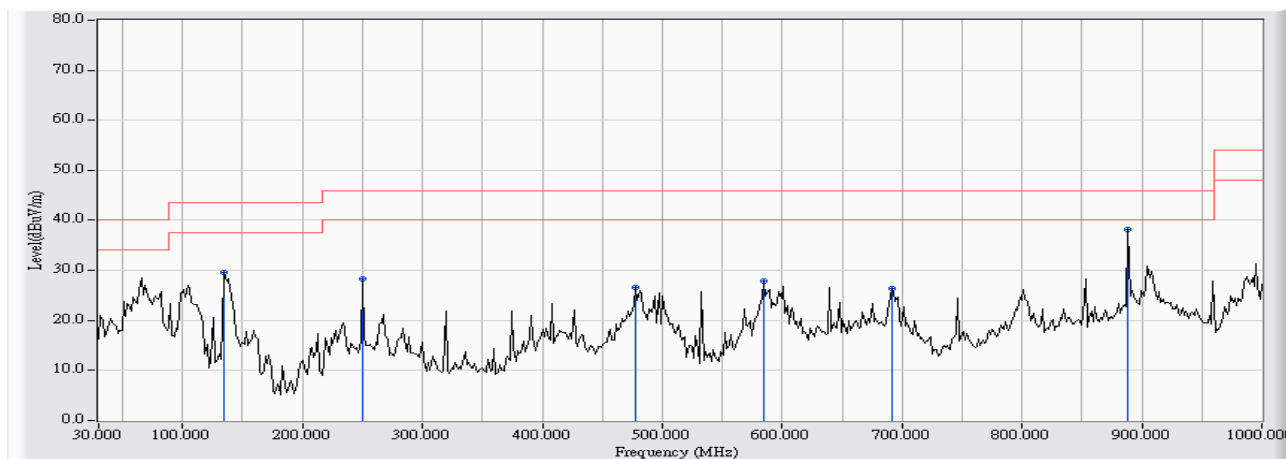

	Frequency (MHz)	Correct Factor (dB)	Reading Level (dBuV)	Measure Level (dBuV/m)	Margin (dB)	Limit (dBuV/m)	Detector Type
1	135.083	-11.868	41.390	29.522	-13.978	43.500	Quasi-Peak
2	249.867	-14.145	42.417	28.272	-17.728	46.000	Quasi-Peak
3	477.817	-4.361	30.962	26.601	-19.399	46.000	Quasi-Peak
4	584.517	-6.303	34.159	27.855	-18.145	46.000	Quasi-Peak
5	691.217	-7.076	33.490	26.414	-19.586	46.000	Quasi-Peak
6	* 888.450	-3.113	41.376	38.263	-7.737	46.000	Quasi-Peak

**Note:**

1. All Reading Levels are Quasi-Peak value.
2. “ \* ”, means this data is the worst emission level.
3. Measurement Level = Reading Level + Correct Factor.

Site : CB1	Time : 2010/11/11 - 11:53
Limit : FCC_CLASS_B_03M_QP	Margin : 6
Probe : FCC_30-1G- HORIZONTAL	Power : AC 120V/60Hz
EUT : Wireless N Day/Night Home Network Camera	Note : Mode 2: Transmit (Adapter: MU06-9050120-A1)-802.11b -2437MHz

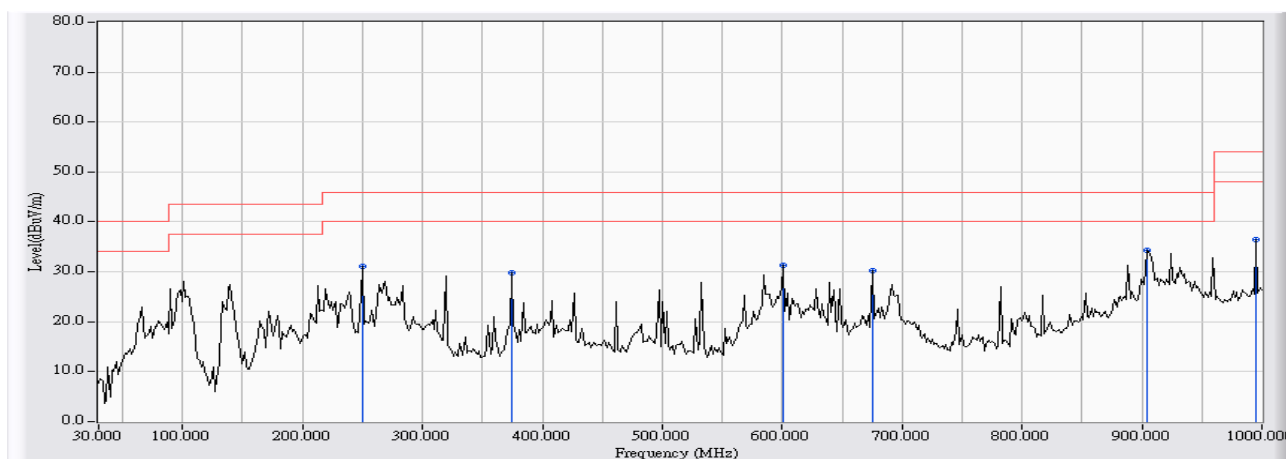

	Frequency (MHz)	Correct Factor (dB)	Reading Level (dBuV)	Measure Level (dBuV/m)	Margin (dB)	Limit (dBuV/m)	Detector Type
1	249.867	-13.345	44.454	31.109	-14.891	46.000	QUASPEAK
2	374.350	-11.196	40.907	29.711	-16.289	46.000	QUASPEAK
3	600.683	-2.795	34.103	31.308	-14.692	46.000	QUASPEAK
4	675.050	-3.408	33.586	30.179	-15.821	46.000	QUASPEAK
5	* 904.617	-1.247	35.497	34.250	-11.750	46.000	QUASPEAK
6	995.150	0.238	36.301	36.539	-17.461	54.000	QUASPEAK

**Note:**

1. All Reading Levels are Quasi-Peak value.
2. “ \* ”, means this data is the worst emission level.
3. Measurement Level = Reading Level + Correct Factor.

Site : CB1	Time : 2010/11/11 - 11:56
Limit : FCC_CLASS_B_03M_QP	Margin : 6
Probe : FCC_30-1G- VERTICAL	Power : AC 120V/60Hz
EUT : Wireless N Day/Night Home Network Camera	Note : Mode 2: Transmit (Adapter: MU06-9050120-A1)-802.11b -2437MHz

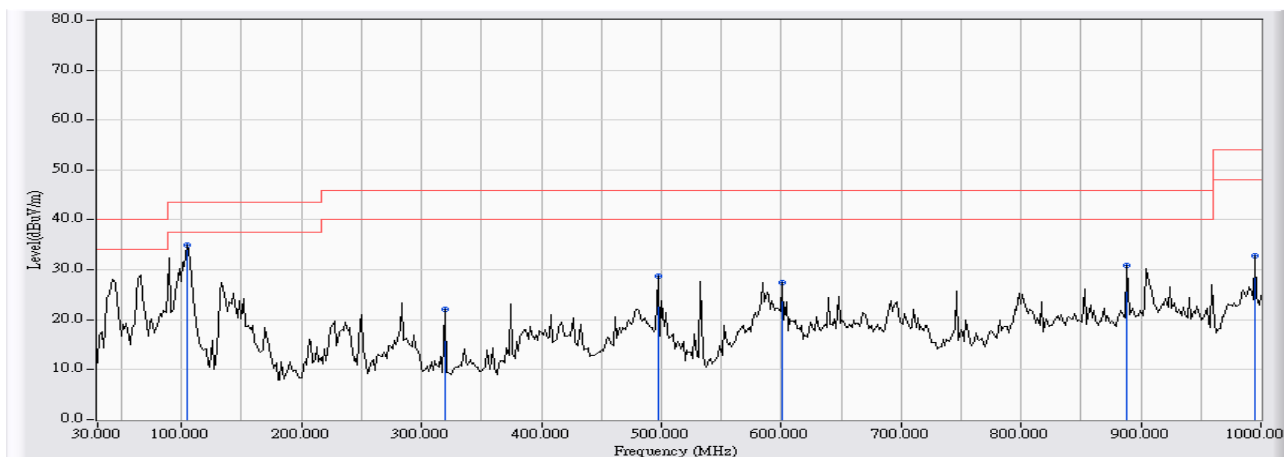

		Frequency (MHz)	Correct Factor (dB)	Reading Level (dBuV)	Measure Level (dBuV/m)	Margin (dB)	Limit (dBuV/m)	Detector Type
1	*	104.367	-12.571	47.562	34.991	-8.509	43.500	QUASPEAK
2		319.383	-13.395	35.537	22.142	-23.858	46.000	QUASPEAK
3		497.217	-6.414	35.068	28.654	-17.346	46.000	QUASPEAK
4		600.683	-3.087	30.469	27.382	-18.618	46.000	QUASPEAK
5		888.450	-3.113	33.943	30.830	-15.170	46.000	QUASPEAK
6		995.150	-1.133	33.931	32.798	-21.202	54.000	QUASPEAK

**Note:**

1. All Reading Levels are Quasi-Peak value.
2. “ \* ”, means this data is the worst emission level.
3. Measurement Level = Reading Level + Correct Factor.

Site : CB1	Time : 2010/11/11 - 12:02
Limit : FCC_CLASS_B_03M_QP	Margin : 6
Probe : FCC_30-1G - HORIZONTAL	Power : AC 120V/60Hz
EUT : Wireless N Day/Night Home Network Camera	Note Mode 2: Transmit (Adapter: MU06-9050120-A1)-802.11g -2437MHz

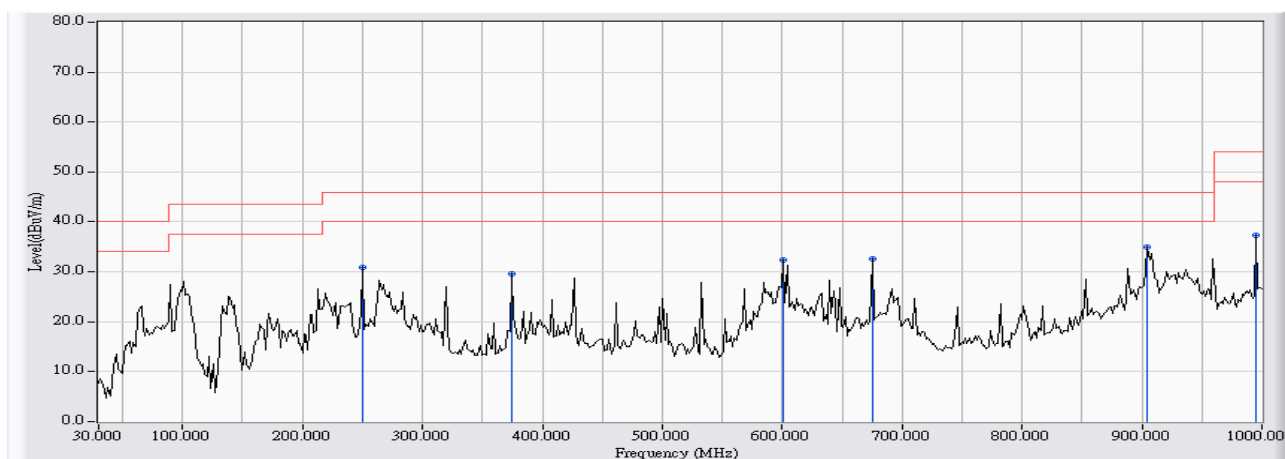

	Frequency (MHz)	Correct Factor (dB)	Reading Level (dBuV)	Measure Level (dBuV/m)	Margin (dB)	Limit (dBuV/m)	Detector Type
1	249.867	-13.345	44.326	30.981	-15.019	46.000	QUASPEAK
2	374.350	-11.196	40.862	29.666	-16.334	46.000	QUASPEAK
3	600.683	-2.795	35.083	32.288	-13.712	46.000	QUASPEAK
4	675.050	-3.408	35.989	32.582	-13.418	46.000	QUASPEAK
5	* 904.617	-1.247	36.293	35.046	-10.954	46.000	QUASPEAK
6	995.150	0.238	37.020	37.258	-16.742	54.000	QUASPEAK

**Note:**

1. All Reading Levels are Quasi-Peak value.
2. “ \* ”, means this data is the worst emission level.
3. Measurement Level = Reading Level + Correct Factor.

Site : CB1	Time : 2010/11/11 - 12:06
Limit : FCC_CLASS_B_03M_QP	Margin : 6
Probe : FCC_30-1G- VERTICAL	Power : AC 120V/60Hz
EUT : Wireless N Day/Night Home Network Camera	Note : Mode 2: Transmit (Adapter: MU06-9050120-A1)-802.11g -2437MHz

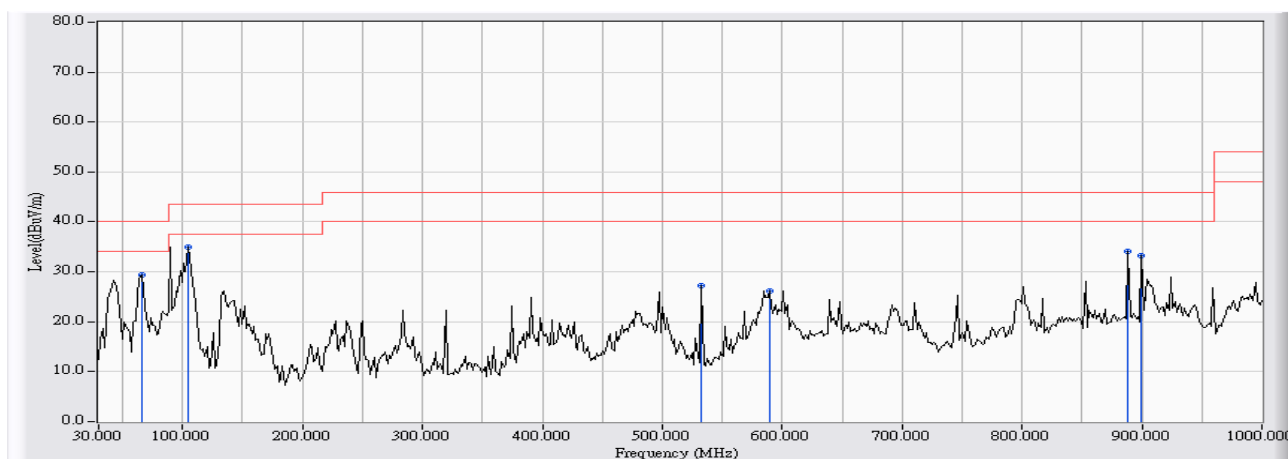

	Frequency (MHz)	Correct Factor (dB)	Reading Level (dBuV)	Measure Level (dBuV/m)	Margin (dB)	Limit (dBuV/m)	Detector Type
1	65.567	-16.219	45.673	29.454	-10.546	40.000	QUASPEAK
2	* 104.367	-12.571	47.608	35.037	-8.463	43.500	QUASPEAK
3	532.783	-10.789	38.002	27.212	-18.788	46.000	QUASPEAK
4	589.367	-4.433	30.673	26.241	-19.759	46.000	QUASPEAK
5	888.450	-3.113	37.242	34.129	-11.871	46.000	QUASPEAK
6	899.767	-3.980	37.190	33.210	-12.790	46.000	QUASPEAK

**Note:**

1. All Reading Levels are Quasi-Peak value.
2. “ \* ”, means this data is the worst emission level.
3. Measurement Level = Reading Level + Correct Factor.

Site : CB1	Time : 2010/11/11 - 13:10
Limit : FCC_CLASS_B_03M_QP	Margin : 6
Probe : FCC_30-1G - HORIZONTAL	Power : AC 120V/60Hz
EUT : Wireless N Day/Night Home Network Camera	Note : Mode 2: Transmit (Adapter: MU06-9050120-A1) -802.11n(20M) -2437MHz

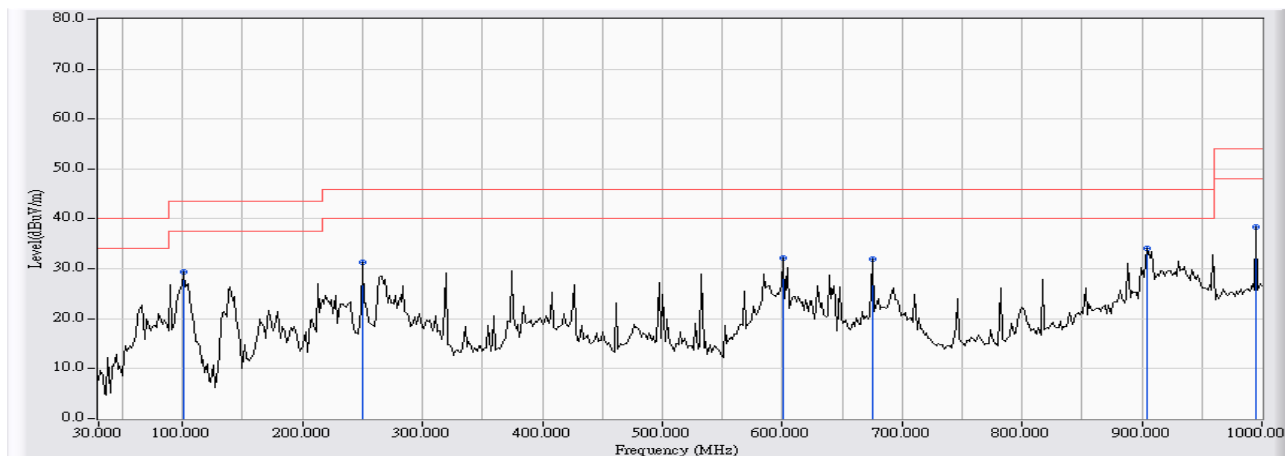

	Frequency (MHz)	Correct Factor (dB)	Reading Level (dBuV)	Measure Level (dBuV/m)	Margin (dB)	Limit (dBuV/m)	Detector Type
1	101.133	-14.649	44.132	29.483	-14.017	43.500	QUASPEAK
2	249.867	-13.345	44.683	31.338	-14.662	46.000	QUASPEAK
3	600.683	-2.795	34.970	32.175	-13.825	46.000	QUASPEAK
4	675.050	-3.408	35.387	31.980	-14.020	46.000	QUASPEAK
5	* 904.617	-1.247	35.357	34.110	-11.890	46.000	QUASPEAK
6	995.150	0.238	38.178	38.416	-15.584	54.000	QUASPEAK

**Note:**

1. All Reading Levels are Quasi-Peak value.
2. “ \* ”, means this data is the worst emission level.
3. Measurement Level = Reading Level + Correct Factor.

Site : CB1	Time : 2010/11/11 - 13:13
Limit : FCC_CLASS_B_03M_QP	Margin : 6
Probe : FCC_30-1G - VERTICAL	Power : AC 120V/60Hz
EUT : Wireless N Day/Night Home Network Camera	Note : Mode 2: Transmit (Adapter: MU06-9050120-A1) -802.11n(20M) -2437MHz

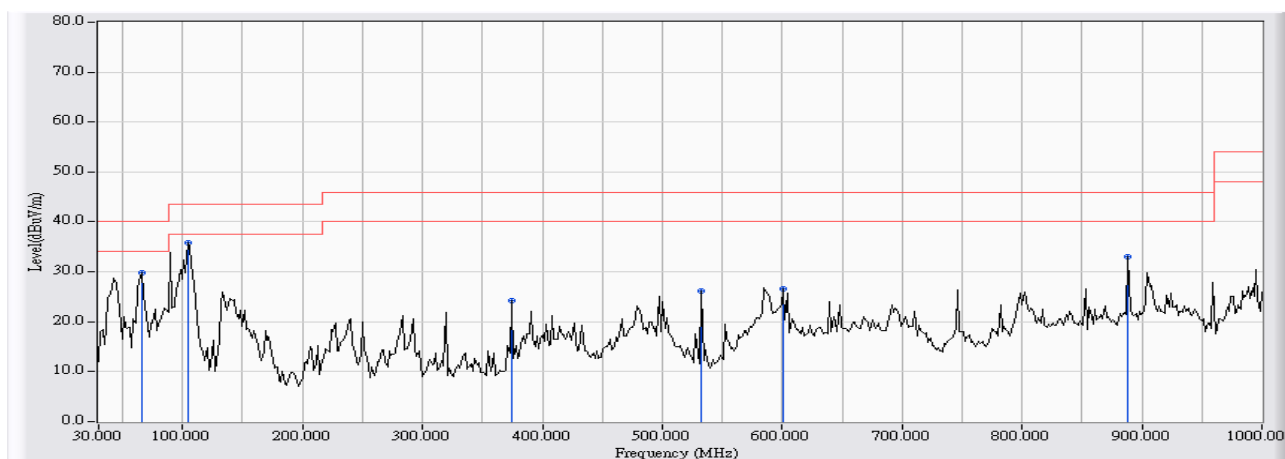

	Frequency (MHz)	Correct Factor (dB)	Reading Level (dBuV)	Measure Level (dBuV/m)	Margin (dB)	Limit (dBuV/m)	Detector Type
1	65.567	-16.219	45.993	29.774	-10.226	40.000	QUASPEAK
2	* 104.367	-12.571	48.455	35.884	-7.616	43.500	QUASPEAK
3	374.350	-12.824	37.123	24.299	-21.701	46.000	QUASPEAK
4	532.783	-10.789	36.894	26.104	-19.896	46.000	QUASPEAK
5	600.683	-3.087	29.706	26.619	-19.381	46.000	QUASPEAK
6	888.450	-3.113	36.124	33.011	-12.989	46.000	QUASPEAK

**Note:**

1. All Reading Levels are Quasi-Peak value.
2. “ \* ”, means this data is the worst emission level.
3. Measurement Level = Reading Level + Correct Factor.

Site : CB1	Time : 2010/11/12 - 09:09
Limit : FCC_CLASS_B_03M_QP	Margin : 6
Probe : FCC_30-1G - HORIZONTAL	Power : AC 120V/60Hz
EUT : Wireless N Day/Night Home Network Camera	Note : Mode 2: Transmit (Adapter: MU06-9050120-A1)-802.11n(40M) -2437MHz

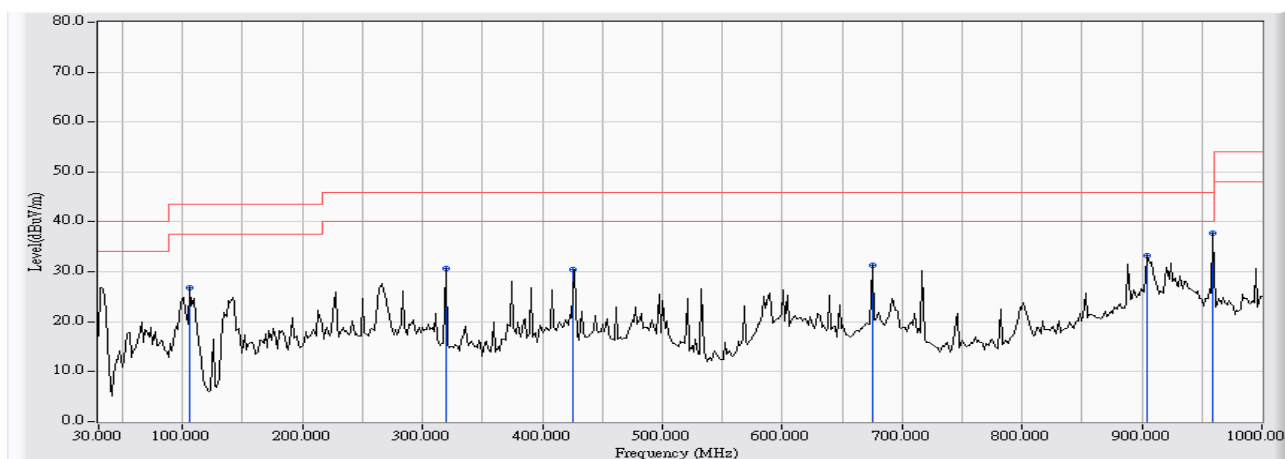

	Frequency (MHz)	Correct Factor (dB)	Reading Level (dBuV)	Measure Level (dBuV/m)	Margin (dB)	Limit (dBuV/m)	Detector Type
1	105.983	-15.660	42.458	26.798	-16.702	43.500	QUASPEAK
2	319.383	-10.873	41.603	30.730	-15.270	46.000	QUASPEAK
3	426.083	-5.040	35.515	30.475	-15.525	46.000	QUASPEAK
4	675.050	-3.408	34.729	31.322	-14.678	46.000	QUASPEAK
5	904.617	-1.247	34.507	33.260	-12.740	46.000	QUASPEAK
6	* 959.583	1.179	36.529	37.708	-8.292	46.000	QUASPEAK

**Note:**

1. All Reading Levels are Quasi-Peak value.
2. “ \* ”, means this data is the worst emission level.
3. Measurement Level = Reading Level + Correct Factor.



Site : CB1	Time : 2010/11/12 - 09:13
Limit : FCC_CLASS_B_03M_QP	Margin : 6
Probe : FCC_30-1G - VERTICAL	Power : AC 120V/60Hz
EUT : Wireless N Day/Night Home Network Camera	Note : Mode 2: Transmit (Adapter: MU06-9050120-A1) -802.11n(40M) -2437MHz

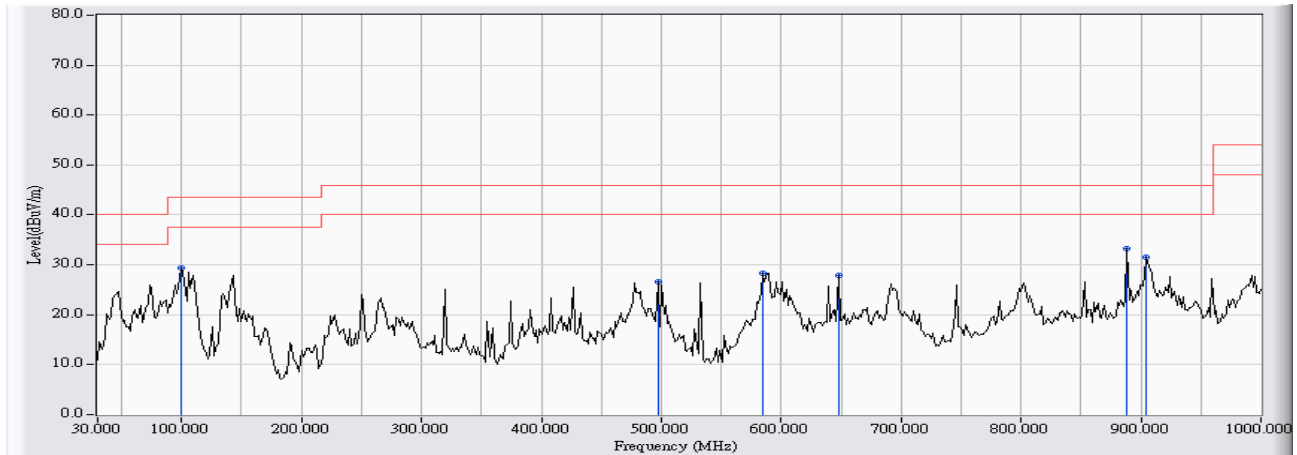

	Frequency (MHz)	Correct Factor (dB)	Reading Level (dBuV)	Measure Level (dBuV/m)	Margin (dB)	Limit (dBuV/m)	Detector Type
1	99.517	-11.685	40.997	29.312	-14.188	43.500	QUASPEAK
2	497.217	-6.414	32.947	26.533	-19.467	46.000	QUASPEAK
3	584.517	-6.303	34.531	28.227	-17.773	46.000	QUASPEAK
4	647.567	-3.004	30.897	27.892	-18.108	46.000	QUASPEAK
5	* 888.450	-3.113	36.457	33.344	-12.656	46.000	QUASPEAK
6	904.617	-3.344	34.963	31.619	-14.381	46.000	QUASPEAK

**Note:**

1. All Reading Levels are Quasi-Peak value.
2. “ \* ”, means this data is the worst emission level.
3. Measurement Level = Reading Level + Correct Factor.

**Harmonic & Spurious:**

Site : CB1	Time : 2010/10/11 - 15:55
Limit : FCC_SpartC_15.247_H_03M_PK	Margin : 6
Probe : FCC_EFS_1-18G - HORIZONTAL	Power : AC 120V/60Hz
EUT : Wireless N Day/Night Home Network Camera	Note : Mode 1: Transmit (Adapter: AMS1-0501200FU)-802.11b-2412MHz

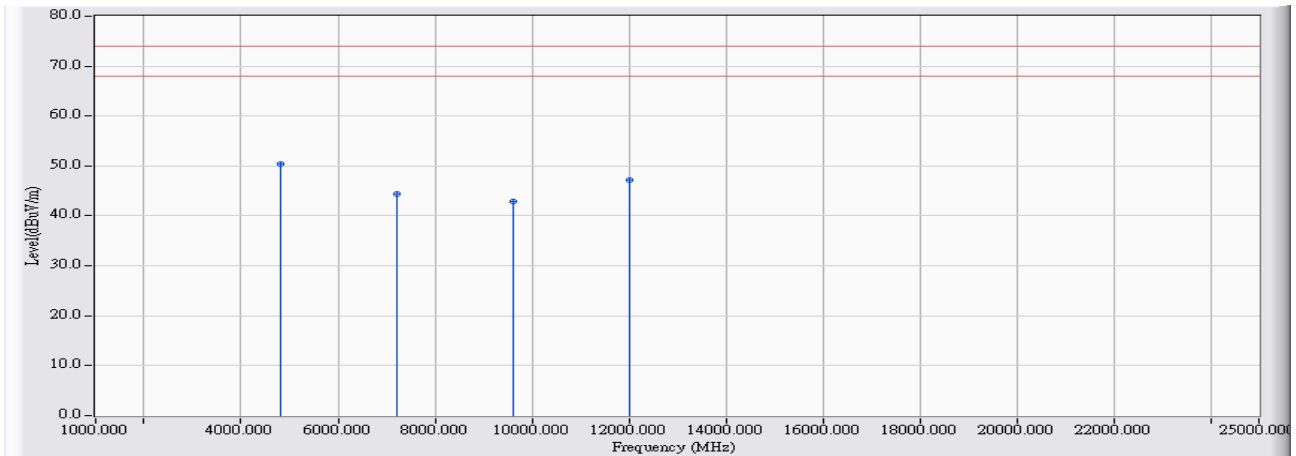

		Frequency (MHz)	Correct Factor (dB)	Reading Level (dBuV)	Measure Level (dBuV/m)	Margin (dB)	Peak Limit (dBuV/m)	Average Limit (dBuV/m)	Detector Type
1	*	4823.960	-0.733	51.070	50.337	-23.663	74.000	54.00	PEAK
2		7226.090	6.267	38.140	44.407	-29.593	74.000	54.00	PEAK
3		9627.530	7.522	35.440	42.963	-31.037	74.000	54.00	PEAK
4		12029.530	10.935	36.300	47.235	-26.765	74.000	54.00	PEAK

**Note:**

1. All readings above 1GHz are performed with peak and/or average measurements as necessary.
2. Peak measurements: RBW = 1MHz, VBW = 3 MHz, Sweep: Auto.
3. Average measurements: RBW = 1MHz, VBW = 10 Hz, Sweep: Auto.
4. “ \* ”, means this data is the worst emission level.
5. Measurement Level = Reading Level + Correct Factor.
6. The average measurement was not performed when the peak measured data under the limit of average detection.
7. The Emission above 13GHz were not included is because their levels are too low.

Site : CB1	Time : 2010/10/11 - 16:06
Limit : FCC_SpartC_15.247_H_03M_PK	Margin : 6
Probe : FCC_EFS_1-18G - VERTICAL	Power : AC 120V/60Hz
EUT : Wireless N Day/Night Home Network Camera	Note : Mode 1: Transmit (Adapter: AMS1-0501200FU) -802.11b-2412MHz

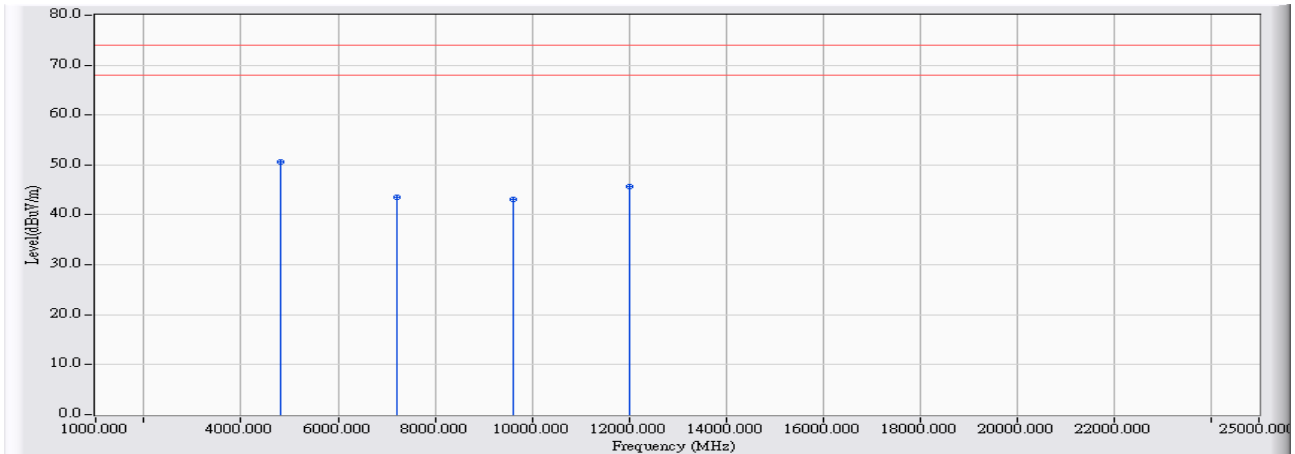

		Frequency (MHz)	Correct Factor (dB)	Reading Level (dBuV)	Measure Level (dBuV/m)	Margin (dB)	Peak Limit (dBuV/m)	Average Limit (dBuV/m)	Detector Type
1	*	4823.990	-0.842	51.420	50.578	-23.422	74.000	54.00	PEAK
2		7225.990	6.392	37.040	43.432	-30.568	74.000	54.00	PEAK
3		9627.990	7.752	35.270	43.023	-30.977	74.000	54.00	PEAK
4		12029.990	9.830	35.790	45.620	-28.380	74.000	54.00	PEAK

**Note:**

1. All readings above 1GHz are performed with peak and/or average measurements as necessary.
2. Peak measurements: RBW = 1MHz, VBW = 3 MHz, Sweep: Auto.
3. Average measurements: RBW = 1MHz, VBW = 10 Hz, Sweep: Auto.
4. “ \* ”, means this data is the worst emission level.
5. Measurement Level = Reading Level + Correct Factor.
6. The average measurement was not performed when the peak measured data under the limit of average detection.
7. The Emission above 13GHz were not included is because their levels are too low.

Site : CB1	Time : 2010/10/15 - 16:17
Limit : FCC_SpartC_15.247_H_03M_PK	Margin : 6
Probe : FCC_EFS_1-18G - HORIZONTAL	Power : AC 120V/60Hz
EUT: Wireless N Day/Night Home Network Camera	Note : Mode 1: Transmit (Adapter: AMS1-0501200FU) -802.11b-2437MHz

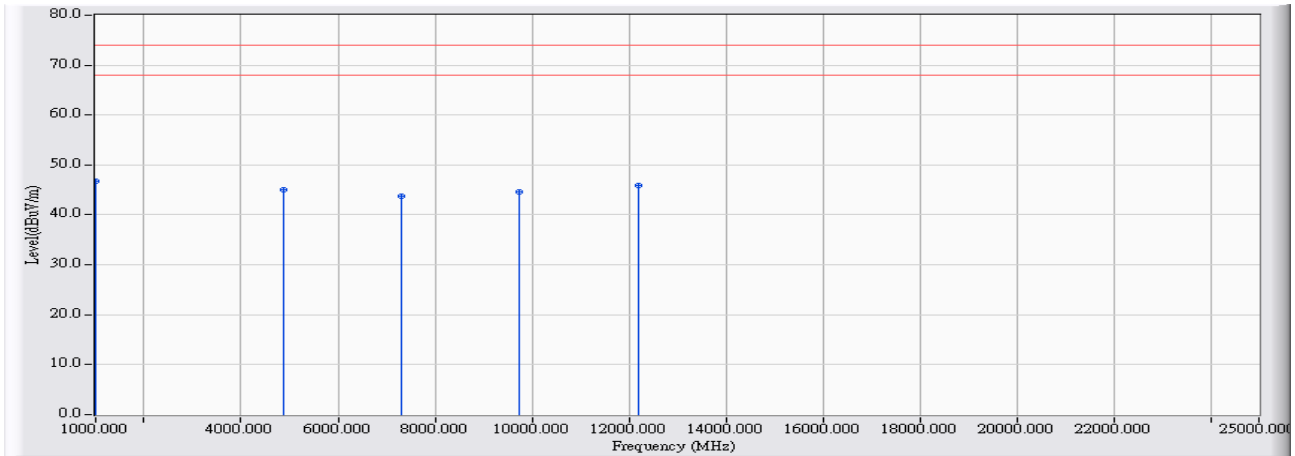

		Frequency (MHz)	Correct Factor (dB)	Reading Level (dBuV)	Measure Level (dBuV/m)	Margin (dB)	Peak Limit (dBuV/m)	Average Limit (dBuV/m)	Detector Type
1	*	1000.000	-9.746	56.395	46.649	-27.351	74.000	54.00	PEAK
2		4874.020	-1.003	46.046	45.044	-28.956	74.000	54.00	PEAK
3		7311.000	6.988	36.664	43.652	-30.348	74.000	54.00	PEAK
4		9748.000	8.007	36.684	44.691	-29.309	74.000	54.00	PEAK
5		12185.000	10.601	35.222	45.824	-28.176	74.000	54.00	PEAK

**Note:**

1. All readings above 1GHz are performed with peak and/or average measurements as necessary.
2. Peak measurements: RBW = 1MHz, VBW = 3 MHz, Sweep: Auto.
3. Average measurements: RBW = 1MHz, VBW = 10 Hz, Sweep: Auto.
4. “ \* ”, means this data is the worst emission level.
5. Measurement Level = Reading Level + Correct Factor.
6. The average measurement was not performed when the peak measured data under the limit of average detection.
7. The Emission above 13GHz were not included is because their levels are too low.

Site : CB1	Time : 2010/10/15 - 16:22
Limit : FCC_SpartC_15.247_H_03M_PK	Margin : 6
Probe : FCC_EFS_1-18G - VERTICAL	Power : AC 120V/60Hz
EUT: Wireless N Day/Night Home Network Camera	Note : Mode 1: Transmit (Adapter: AMS1-0501200FU)-802.11b-2437MHz

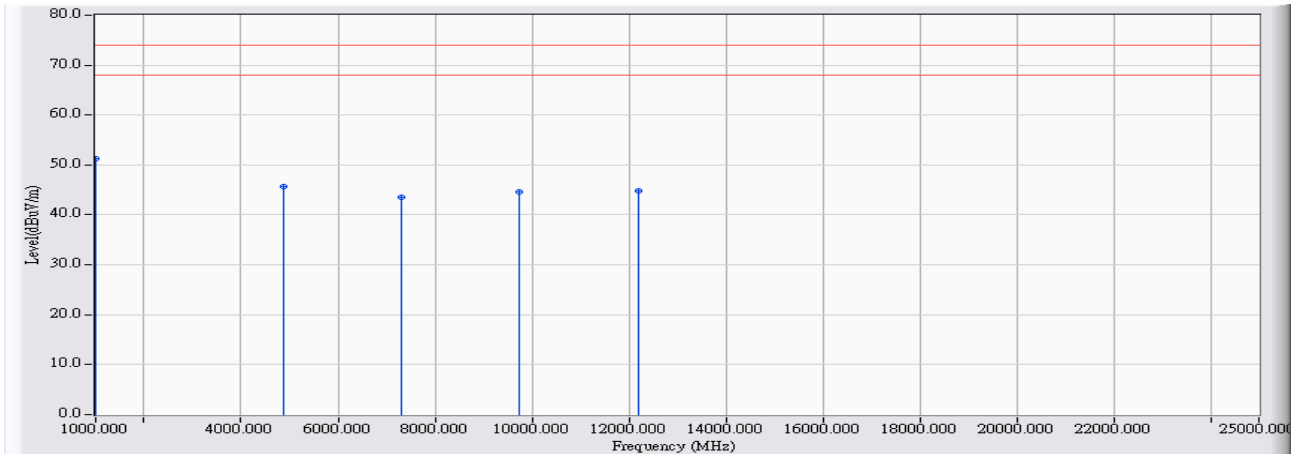

		Frequency (MHz)	Correct Factor (dB)	Reading Level (dBuV)	Measure Level (dBuV/m)	Margin (dB)	Peak Limit (dBuV/m)	Average Limit (dBuV/m)	Detector Type
1	*	1000.000	-7.776	58.972	51.196	-22.804	74.000	54.00	PEAK
2		4874.010	-1.042	46.830	45.788	-28.212	74.000	54.00	PEAK
3		7311.000	6.769	36.678	43.447	-30.553	74.000	54.00	PEAK
4		9748.000	8.165	36.435	44.600	-29.400	74.000	54.00	PEAK
5		12185.000	9.516	35.277	44.794	-29.206	74.000	54.00	PEAK

**Note:**

1. All readings above 1GHz are performed with peak and/or average measurements as necessary.
2. Peak measurements: RBW = 1MHz, VBW = 3 MHz, Sweep: Auto.
3. Average measurements: RBW = 1MHz, VBW = 10 Hz, Sweep: Auto.
4. “ \* ”, means this data is the worst emission level.
5. Measurement Level = Reading Level + Correct Factor.
6. The average measurement was not performed when the peak measured data under the limit of average detection.
7. The Emission above 13GHz were not included is because their levels are too low.

Site : CB1	Time : 2010/10/11 - 16:20
Limit : FCC_SpartC_15.247_H_03M_PK	Margin : 6
Probe : FCC_EFS_1-18G - HORIZONTAL	Power : AC 120V/60Hz
EUT : Wireless N Day/Night Home Network Camera	Note : Mode 1: Transmit (Adapter: AMS1-0501200FU)-802.11b-2462MHz

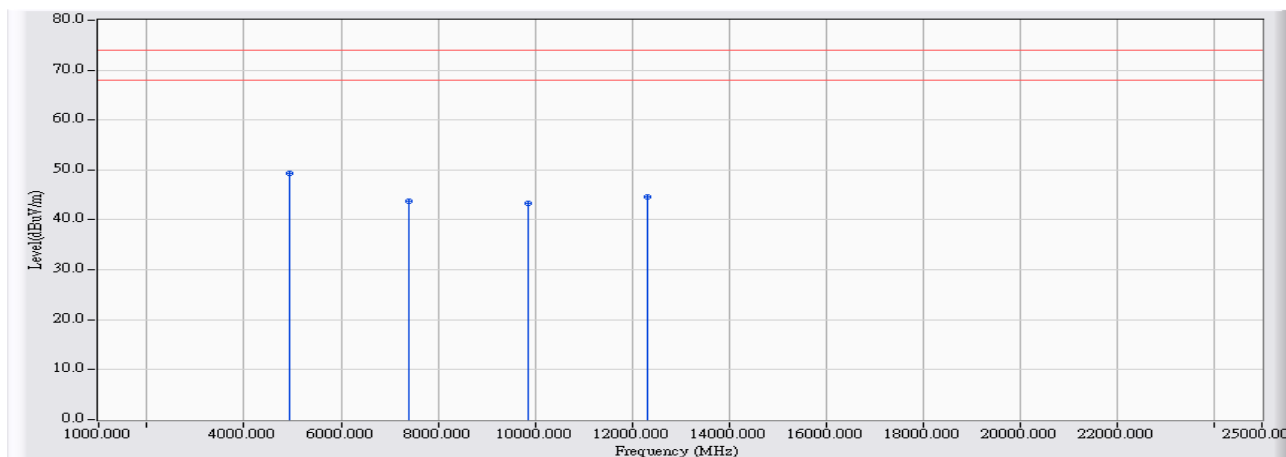

		Frequency (MHz)	Correct Factor (dB)	Reading Level (dBuV)	Measure Level (dBuV/m)	Margin (dB)	Peak Limit (dBuV/m)	Average Limit (dBuV/m)	Detector Type
1	*	4923.900	-0.547	49.980	49.433	-24.567	74.000	54.00	PEAK
2		7385.900	7.669	36.000	43.669	-30.331	74.000	54.00	PEAK
3		9847.900	8.244	35.090	43.333	-30.667	74.000	54.00	PEAK
4		12309.000	9.277	35.300	44.577	-29.423	74.000	54.00	PEAK

**Note:**

1. All readings above 1GHz are performed with peak and/or average measurements as necessary.
2. Peak measurements: RBW = 1MHz, VBW = 3 MHz, Sweep: Auto.
3. Average measurements: RBW = 1MHz, VBW = 10 Hz, Sweep: Auto.
4. “ \* ”, means this data is the worst emission level.
5. Measurement Level = Reading Level + Correct Factor.
6. The average measurement was not performed when the peak measured data under the limit of average detection.
7. The Emission above 13GHz were not included is because their levels are too low.

Site : CB1	Time : 2010/10/11 - 16:27
Limit : FCC_SpartC_15.247_H_03M_PK	Margin : 6
Probe : FCC_EFS_1-18G - VERTICAL	Power : AC 120V/60Hz
EUT : Wireless N Day/Night Home Network Camera	Note : Mode 1: Transmit (Adapter: AMS1-0501200FU)-802.11b-2462MHz

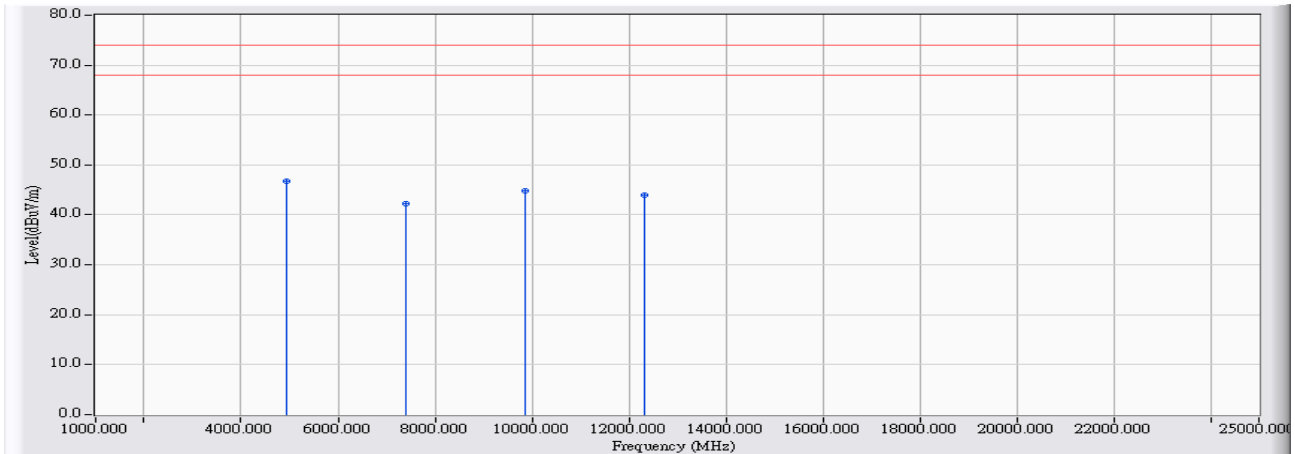

		Frequency (MHz)	Correct Factor (dB)	Reading Level (dBuV)	Measure Level (dBuV/m)	Margin (dB)	Peak Limit (dBuV/m)	Average Limit (dBuV/m)	Detector Type
1	*	4923.970	-0.535	47.350	46.815	-27.185	74.000	54.00	PEAK
2		7385.800	7.147	35.160	42.306	-31.694	74.000	54.00	PEAK
3		9847.800	8.353	36.570	44.922	-29.078	74.000	54.00	PEAK
4		12309.730	8.194	35.870	44.064	-29.936	74.000	54.00	PEAK

**Note:**

1. All readings above 1GHz are performed with peak and/or average measurements as necessary.
2. Peak measurements: RBW = 1MHz, VBW = 3 MHz, Sweep: Auto.
3. Average measurements: RBW = 1MHz, VBW = 10 Hz, Sweep: Auto.
4. “ \* ”, means this data is the worst emission level.
5. Measurement Level = Reading Level + Correct Factor.
6. The average measurement was not performed when the peak measured data under the limit of average detection.
7. The Emission above 13GHz were not included is because their levels are too low.

Site : CB1	Time : 2010/10/11 - 16:36
Limit : FCC_SpartC_15.247_H_03M_PK	Margin : 6
Probe : FCC_EFS_1-18G - HORIZONTAL	Power : AC 120V/60Hz
EUT : Wireless N Day/Night Home Network Camera	Note : Mode 1: Transmit (Adapter: AMS1-0501200FU)-802.11g-2412MHz

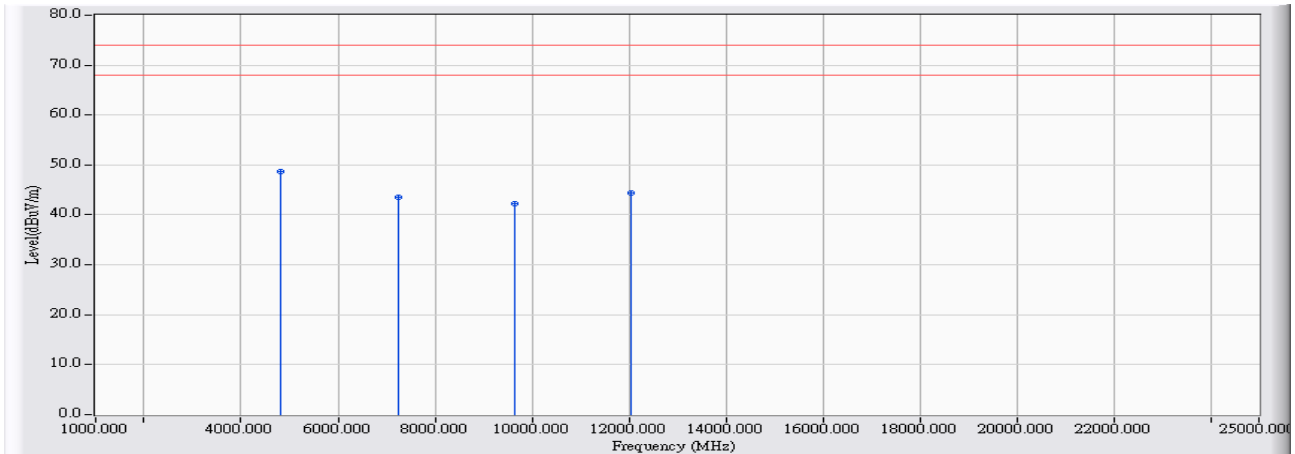

		Frequency (MHz)	Correct Factor (dB)	Reading Level (dBuV)	Measure Level (dBuV/m)	Margin (dB)	Peak Limit (dBuV/m)	Average Limit (dBuV/m)	Detector Type
1	*	4823.920	-0.733	49.500	48.767	-25.233	74.000	54.00	PEAK
2		7235.920	6.345	37.160	43.505	-30.495	74.000	54.00	PEAK
3		9647.920	7.567	34.720	42.287	-31.713	74.000	54.00	PEAK
4		12059.920	11.038	33.460	44.499	-29.501	74.000	54.00	PEAK

**Note:**

1. All readings above 1GHz are performed with peak and/or average measurements as necessary.
2. Peak measurements: RBW = 1MHz, VBW = 3 MHz, Sweep: Auto.
3. Average measurements: RBW = 1MHz, VBW = 10 Hz, Sweep: Auto.
4. “ \* ”, means this data is the worst emission level.
5. Measurement Level = Reading Level + Correct Factor.
6. The average measurement was not performed when the peak measured data under the limit of average detection.
7. The Emission above 13GHz were not included is because their levels are too low.



Site : CB1	Time : 2010/10/11 - 16:44
Limit : FCC_SpartC_15.247_H_03M_PK	Margin : 6
Probe : FCC_EFS_1-18G - VERTICAL	Power : AC 120V/60Hz
EUT : Wireless N Day/Night Home Network Camera	Note : Mode 1: Transmit (Adapter: AMS1-0501200FU)-802.11g-2412MHz

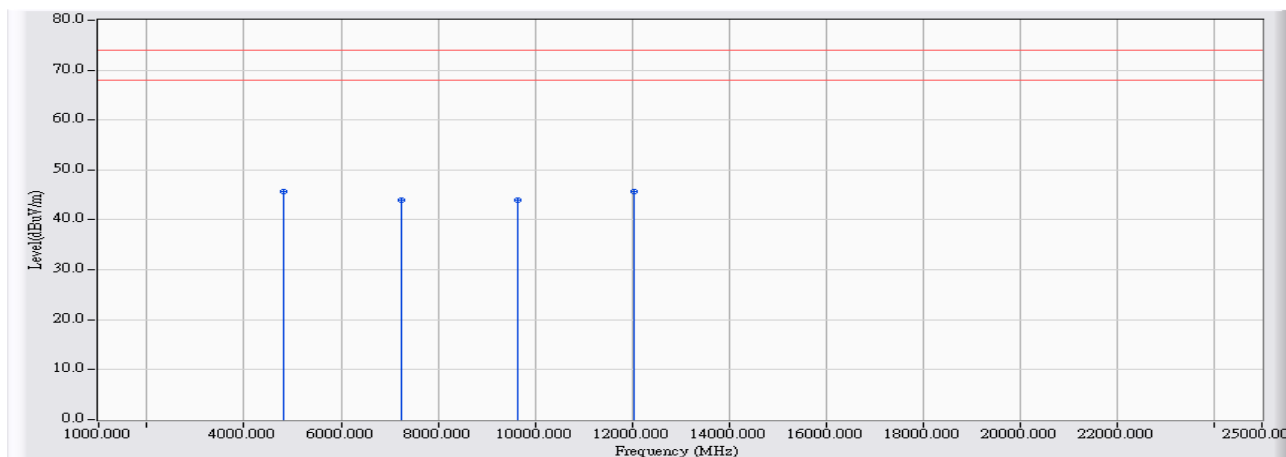

	Frequency (MHz)	Correct Factor (dB)	Reading Level (dBuV)	Measure Level (dBuV/m)	Margin (dB)	Peak Limit (dBuV/m)	Average Limit (dBuV/m)	Detector Type
1	4823.920	-0.842	46.490	45.648	-28.352	74.000	54.00	PEAK
2	7235.920	6.431	37.580	44.010	-29.990	74.000	54.00	PEAK
3	9647.920	7.784	36.090	43.874	-30.126	74.000	54.00	PEAK
4	* 12059.920	9.931	35.820	45.751	-28.249	74.000	54.00	PEAK

**Note:**

1. All readings above 1GHz are performed with peak and/or average measurements as necessary.
2. Peak measurements: RBW = 1MHz, VBW = 3 MHz, Sweep: Auto.
3. Average measurements: RBW = 1MHz, VBW = 10 Hz, Sweep: Auto.
4. “ \* ”, means this data is the worst emission level.
5. Measurement Level = Reading Level + Correct Factor.
6. The average measurement was not performed when the peak measured data under the limit of average detection.
7. The Emission above 13GHz were not included is because their levels are too low.

Site : CB1	Time : 2010/10/15 - 16:48
Limit : FCC_SpartC_15.247_H_03M_PK	Margin : 6
Probe : FCC_EFS_1-18G - HORIZONTAL	Power : AC 120V/60Hz
EUT: Wireless N Day/Night Home Network Camera	Note : Mode 1: Transmit (Adapter: AMS1-0501200FU)-802.11g-2437MHz

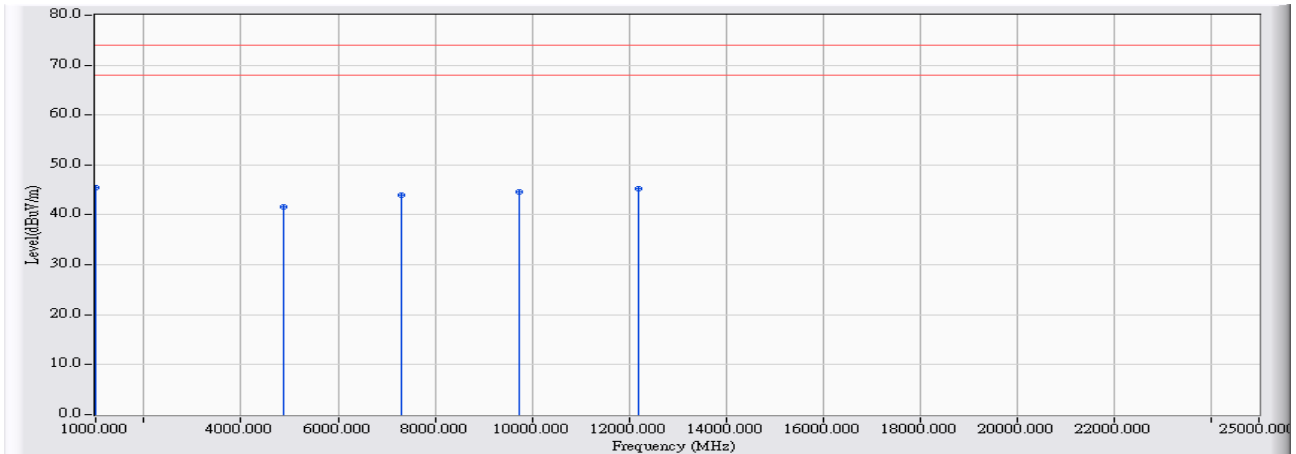

		Frequency (MHz)	Correct Factor (dB)	Reading Level (dBuV)	Measure Level (dBuV/m)	Margin (dB)	Peak Limit (dBuV/m)	Average Limit (dBuV/m)	Detector Type
1	*	1000.000	-9.746	55.306	45.560	-28.440	74.000	54.00	PEAK
2		4874.000	-1.003	42.626	41.624	-32.376	74.000	54.00	PEAK
3		7311.000	6.988	37.013	44.001	-29.999	74.000	54.00	PEAK
4		9748.000	8.007	36.696	44.703	-29.297	74.000	54.00	PEAK
5		12185.000	10.601	34.751	45.353	-28.647	74.000	54.00	PEAK

Note:

1. All readings above 1GHz are performed with peak and/or average measurements as necessary.
2. Peak measurements: RBW = 1MHz, VBW = 3 MHz, Sweep: Auto.
3. Average measurements: RBW = 1MHz, VBW = 10 Hz, Sweep: Auto.
4. “ \* ”, means this data is the worst emission level.
5. Measurement Level = Reading Level + Correct Factor.
6. The average measurement was not performed when the peak measured data under the limit of average detection.
7. The Emission above 13GHz were not included is because their levels are too low.

Site : CB1	Time : 2010/10/15 - 16:53
Limit : FCC_SpartC_15.247_H_03M_PK	Margin : 6
Probe : FCC_EFS_1-18G - VERTICAL	Power : AC 120V/60Hz
EUT: Wireless N Day/Night Home Network Camera	Note : Mode 1: Transmit (Adapter: AMS1-0501200FU)-802.11g-2437MHz

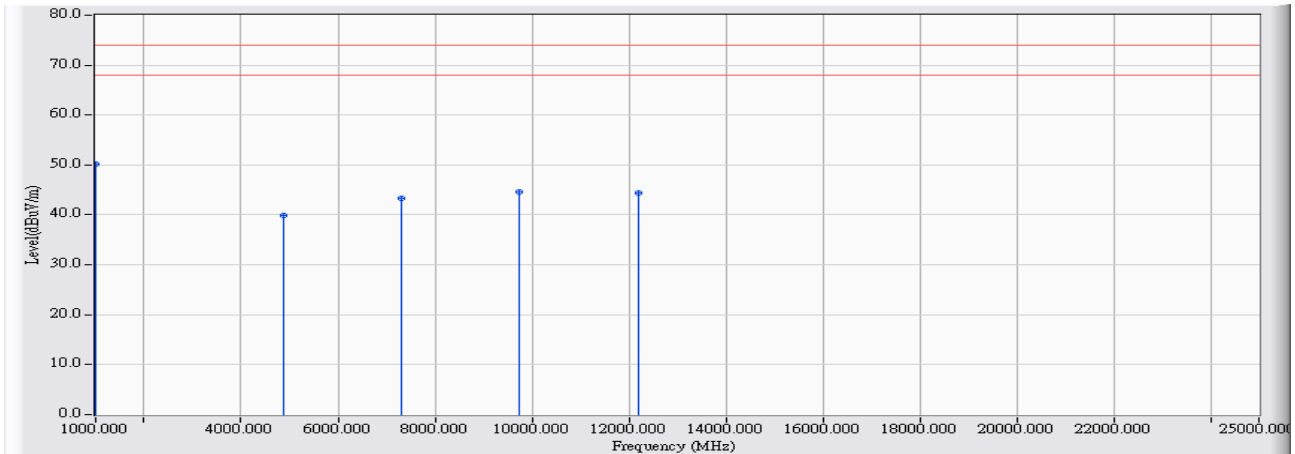

		Frequency (MHz)	Correct Factor (dB)	Reading Level (dBuV)	Measure Level (dBuV/m)	Margin (dB)	Peak Limit (dBuV/m)	Average Limit (dBuV/m)	Detector Type
1	*	1000.000	-7.776	58.020	50.244	-23.756	74.000	54.00	PEAK
2		4874.000	-1.042	40.890	39.848	-34.152	74.000	54.00	PEAK
3		7311.000	6.769	36.476	43.245	-30.755	74.000	54.00	PEAK
4		9748.000	8.165	36.420	44.585	-29.415	74.000	54.00	PEAK
5		12185.000	9.516	34.903	44.420	-29.580	74.000	54.00	PEAK

**Note:**

1. All readings above 1GHz are performed with peak and/or average measurements as necessary.
2. Peak measurements: RBW = 1MHz, VBW = 3 MHz, Sweep: Auto.
3. Average measurements: RBW = 1MHz, VBW = 10 Hz, Sweep: Auto.
4. “ \* ”, means this data is the worst emission level.
5. Measurement Level = Reading Level + Correct Factor.
6. The average measurement was not performed when the peak measured data under the limit of average detection.
7. The Emission above 13GHz were not included is because their levels are too low.

Site : CB1	Time : 2010/10/11 - 16:54
Limit : FCC_SpartC_15.247_H_03M_PK	Margin : 6
Probe : FCC_EFS_1-18G - HORIZONTAL	Power : AC 120V/60Hz
EUT : Wireless N Day/Night Home Network Camera	Note : Mode 1: Transmit (Adapter: AMS1-0501200FU)-802.11g-2462MHz

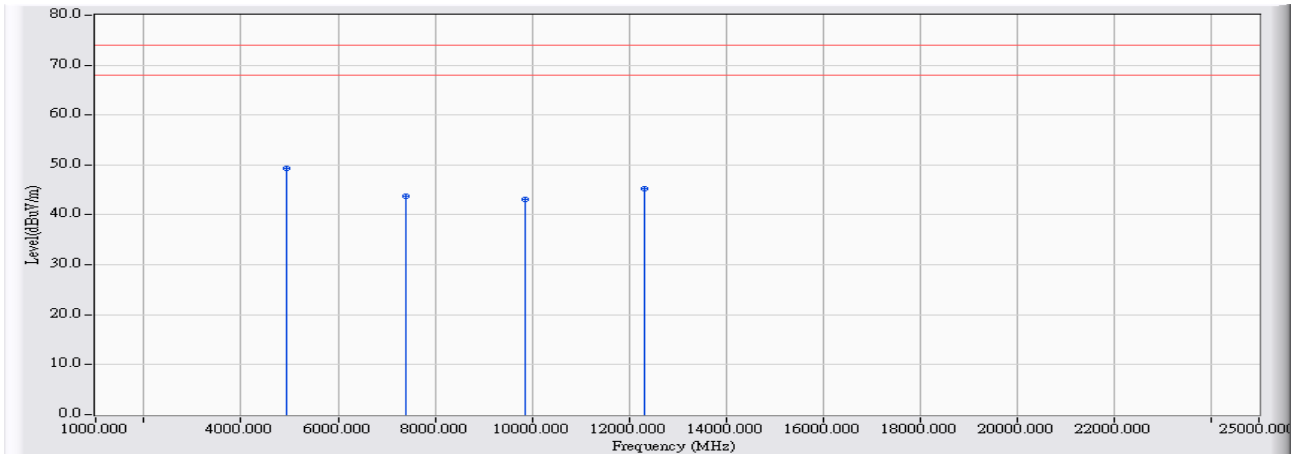

		Frequency (MHz)	Correct Factor (dB)	Reading Level (dBuV)	Measure Level (dBuV/m)	Margin (dB)	Peak Limit (dBuV/m)	Average Limit (dBuV/m)	Detector Type
1	*	4923.920	-0.547	49.980	49.433	-24.567	74.000	54.00	PEAK
2		7385.920	7.669	36.040	43.709	-30.291	74.000	54.00	PEAK
3		9848.170	8.241	34.950	43.191	-30.809	74.000	54.00	PEAK
4		12310.170	9.273	35.890	45.162	-28.838	74.000	54.00	PEAK

**Note:**

1. All readings above 1GHz are performed with peak and/or average measurements as necessary.
2. Peak measurements: RBW = 1MHz, VBW = 3 MHz, Sweep: Auto.
3. Average measurements: RBW = 1MHz, VBW = 10 Hz, Sweep: Auto.
4. “ \* ”, means this data is the worst emission level.
5. Measurement Level = Reading Level + Correct Factor.
6. The average measurement was not performed when the peak measured data under the limit of average detection.
7. The Emission above 13GHz were not included is because their levels are too low.

Site : CB1	Time : 2010/10/11 - 16:59
Limit : FCC_SpartC_15.247_H_03M_PK	Margin : 6
Probe : FCC_EFS_1-18G - VERTICAL	Power : AC 120V/60Hz
EUT : Wireless N Day/Night Home Network Camera	Note : Mode 1: Transmit (Adapter: AMS1-0501200FU)-802.11g-2462MHz

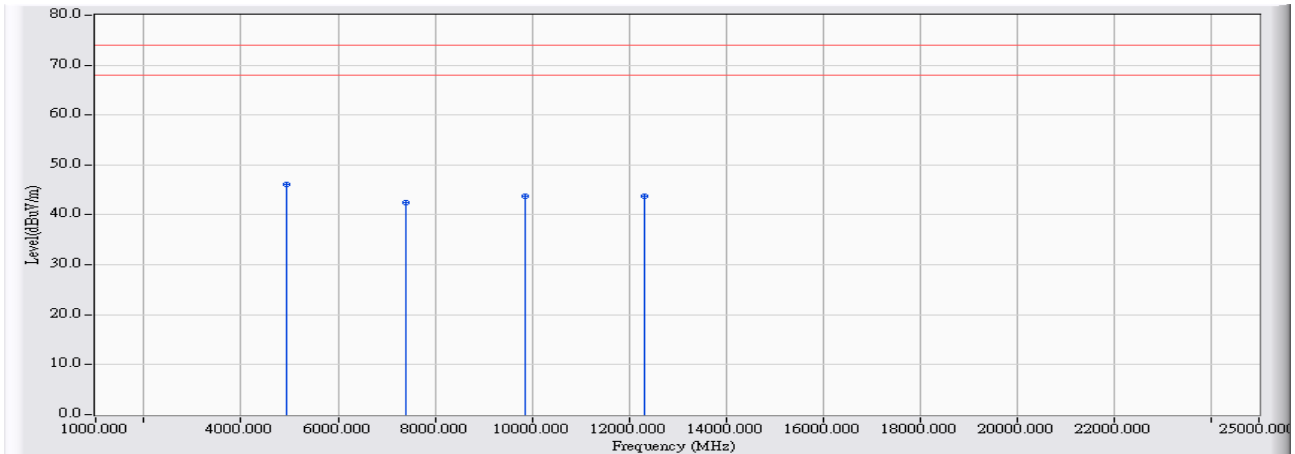

		Frequency (MHz)	Correct Factor (dB)	Reading Level (dBuV)	Measure Level (dBuV/m)	Margin (dB)	Peak Limit (dBuV/m)	Average Limit (dBuV/m)	Detector Type
1	*	4924.000	-0.535	46.660	46.126	-27.874	74.000	54.00	PEAK
2		7386.000	7.148	35.410	42.558	-31.442	74.000	54.00	PEAK
3		9848.000	8.351	35.400	43.750	-30.250	74.000	54.00	PEAK
4		12310.000	8.193	35.610	43.803	-30.197	74.000	54.00	PEAK

**Note:**

1. All readings above 1GHz are performed with peak and/or average measurements as necessary.
2. Peak measurements: RBW = 1MHz, VBW = 3 MHz, Sweep: Auto.
3. Average measurements: RBW = 1MHz, VBW = 10 Hz, Sweep: Auto.
4. “ \* ”, means this data is the worst emission level.
5. Measurement Level = Reading Level + Correct Factor.
6. The average measurement was not performed when the peak measured data under the limit of average detection.
7. The Emission above 13GHz were not included is because their levels are too low.

Site : CB1	Time : 2010/10/11 - 17:15
Limit : FCC_SpartC_15.247_H_03M_PK	Margin : 6
Probe : FCC_EFS_1-18G - HORIZONTAL	Power : AC 120V/60Hz
EUT : Wireless N Day/Night Home Network Camera	Note : Mode 1: Transmit (Adapter: AMS1-0501200FU)-802.11n(20M)-2412MHz

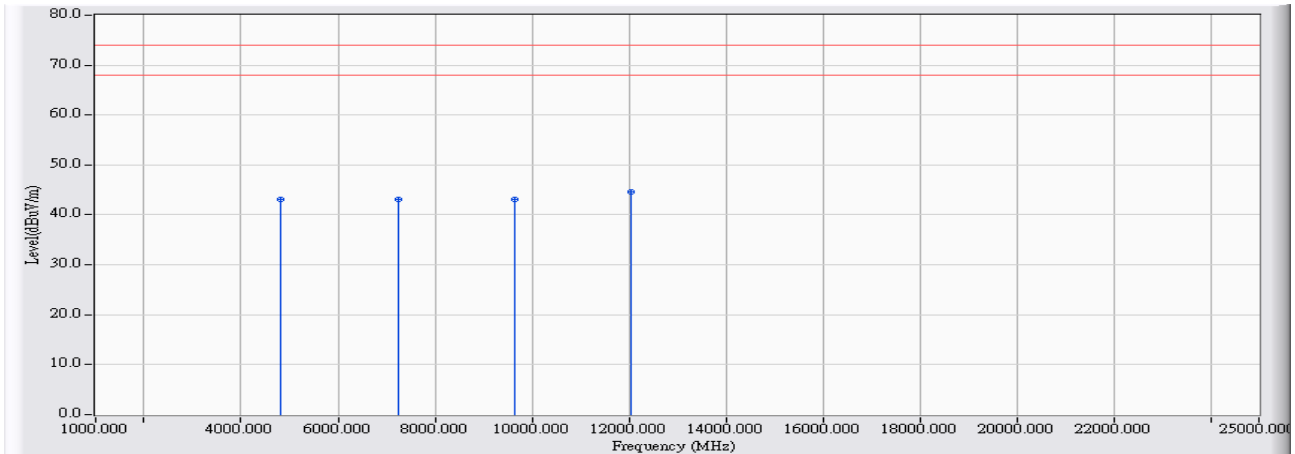

	Frequency (MHz)	Correct Factor (dB)	Reading Level (dBuV)	Measure Level (dBuV/m)	Margin (dB)	Peak Limit (dBuV/m)	Average Limit (dBuV/m)	Detector Type
1	4824.170	-0.732	43.870	43.137	-30.863	74.000	54.00	PEAK
2	7236.170	6.347	36.870	43.217	-30.783	74.000	54.00	PEAK
3	9648.170	7.567	35.570	43.138	-30.862	74.000	54.00	PEAK
4	* 12060.170	11.041	33.550	44.590	-29.410	74.000	54.00	PEAK

**Note:**

1. All readings above 1GHz are performed with peak and/or average measurements as necessary.
2. Peak measurements: RBW = 1MHz, VBW = 3 MHz, Sweep: Auto.
3. Average measurements: RBW = 1MHz, VBW = 10 Hz, Sweep: Auto.
4. “ \* ”, means this data is the worst emission level.
5. Measurement Level = Reading Level + Correct Factor.
6. The average measurement was not performed when the peak measured data under the limit of average detection.
7. The Emission above 13GHz were not included is because their levels are too low.

Site : CB1	Time : 2010/10/11 - 17:22
Limit : FCC_SpartC_15.247_H_03M_PK	Margin : 6
Probe : FCC_EFS_1-18G - VERTICAL	Power : AC 120V/60Hz
EUT : Wireless N Day/Night Home Network Camera	Note : Mode 1: Transmit (Adapter: AMS1-0501200FU)-802.11n(20M)-2412MHz

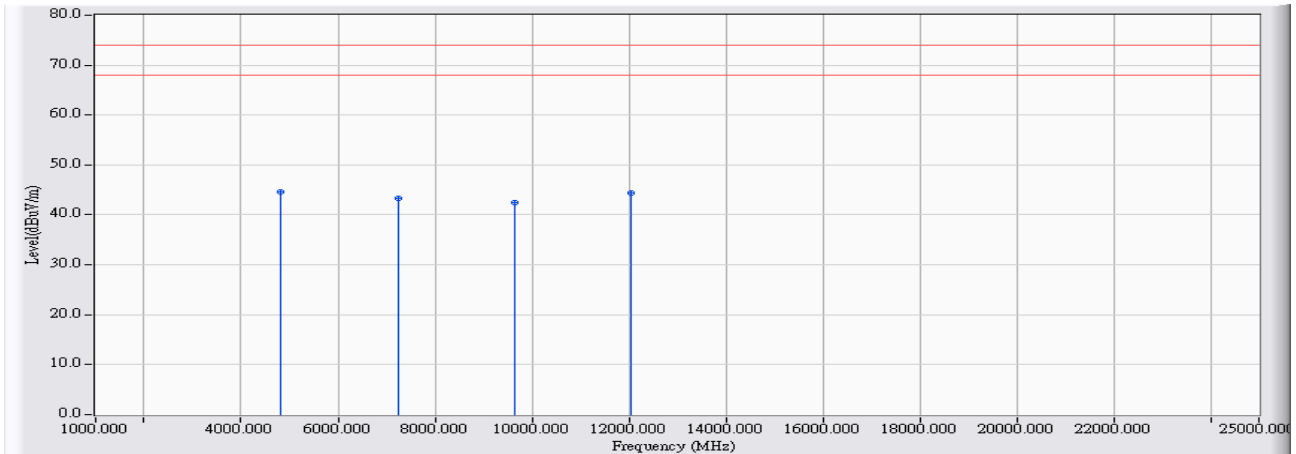

		Frequency (MHz)	Correct Factor (dB)	Reading Level (dBuV)	Measure Level (dBuV/m)	Margin (dB)	Peak Limit (dBuV/m)	Average Limit (dBuV/m)	Detector Type
1	*	4824.170	-0.841	45.450	44.608	-29.392	74.000	54.00	PEAK
2		7236.170	6.431	36.990	43.421	-30.579	74.000	54.00	PEAK
3		9648.170	7.785	34.600	42.385	-31.615	74.000	54.00	PEAK
4		12060.170	9.933	34.410	44.343	-29.657	74.000	54.00	PEAK

**Note:**

1. All readings above 1GHz are performed with peak and/or average measurements as necessary.
2. Peak measurements: RBW = 1MHz, VBW = 3 MHz, Sweep: Auto.
3. Average measurements: RBW = 1MHz, VBW = 10 Hz, Sweep: Auto.
4. “ \* ”, means this data is the worst emission level.
5. Measurement Level = Reading Level + Correct Factor.
6. The average measurement was not performed when the peak measured data under the limit of average detection.
7. The Emission above 13GHz were not included is because their levels are too low.

Site : CB1	Time : 2010/10/15 - 17:16
Limit : FCC_SpartC_15.247_H_03M_PK	Margin : 6
Probe : FCC_EFS_1-18G - HORIZONTAL	Power : AC 120V/60Hz
EUT: Wireless N Day/Night Home Network Camera	Note : Mode 1: Transmit (Adapter: AMS1-0501200FU)-802.11n(20M)-2437MHz

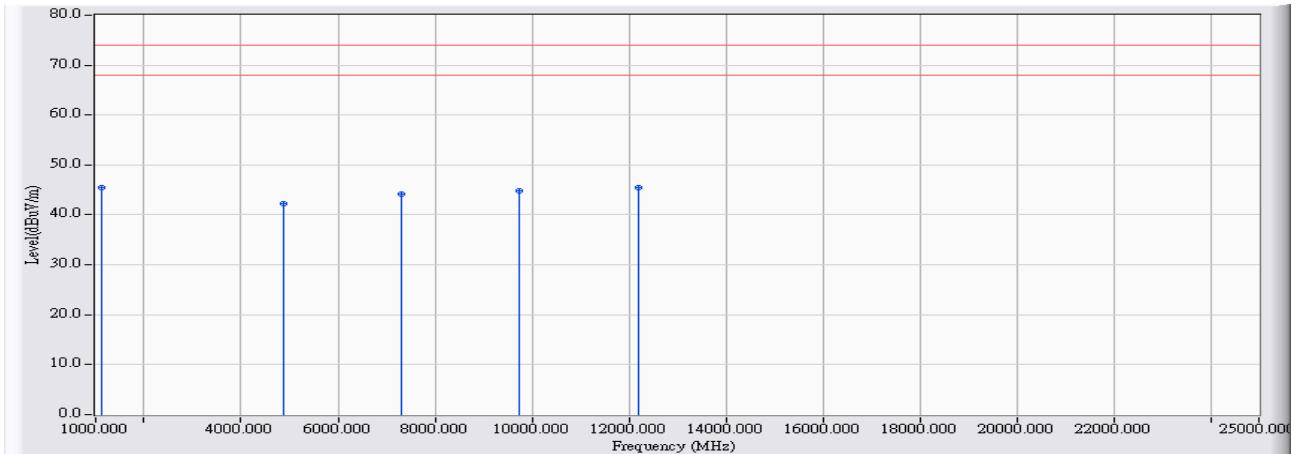

		Frequency (MHz)	Correct Factor (dB)	Reading Level (dBuV)	Measure Level (dBuV/m)	Margin (dB)	Peak Limit (dBuV/m)	Average Limit (dBuV/m)	Detector Type
1	*	1120.000	-10.765	56.318	45.553	-28.447	74.000	54.00	PEAK
2		4874.020	-1.003	43.185	42.183	-31.817	74.000	54.00	PEAK
3		7311.000	6.988	37.226	44.214	-29.786	74.000	54.00	PEAK
4		9748.000	8.007	36.838	44.845	-29.155	74.000	54.00	PEAK
5		12185.000	10.601	34.826	45.428	-28.572	74.000	54.00	PEAK

**Note:**

1. All readings above 1GHz are performed with peak and/or average measurements as necessary.
2. Peak measurements: RBW = 1MHz, VBW = 3 MHz, Sweep: Auto.
3. Average measurements: RBW = 1MHz, VBW = 10 Hz, Sweep: Auto.
4. “ \* ”, means this data is the worst emission level.
5. Measurement Level = Reading Level + Correct Factor.
6. The average measurement was not performed when the peak measured data under the limit of average detection.
7. The Emission above 13GHz were not included is because their levels are too low.



Site : CB1	Time : 2010/10/15 - 17:21
Limit : FCC_SpartC_15.247_H_03M_PK	Margin : 6
Probe : FCC_EFS_1-18G - VERTICAL	Power : AC 120V/60Hz
EUT: Wireless N Day/Night Home Network Camera	Note : Mode 1: Transmit (Adapter: AMS1-0501200FU)-802.11n(20M)-2437MHz

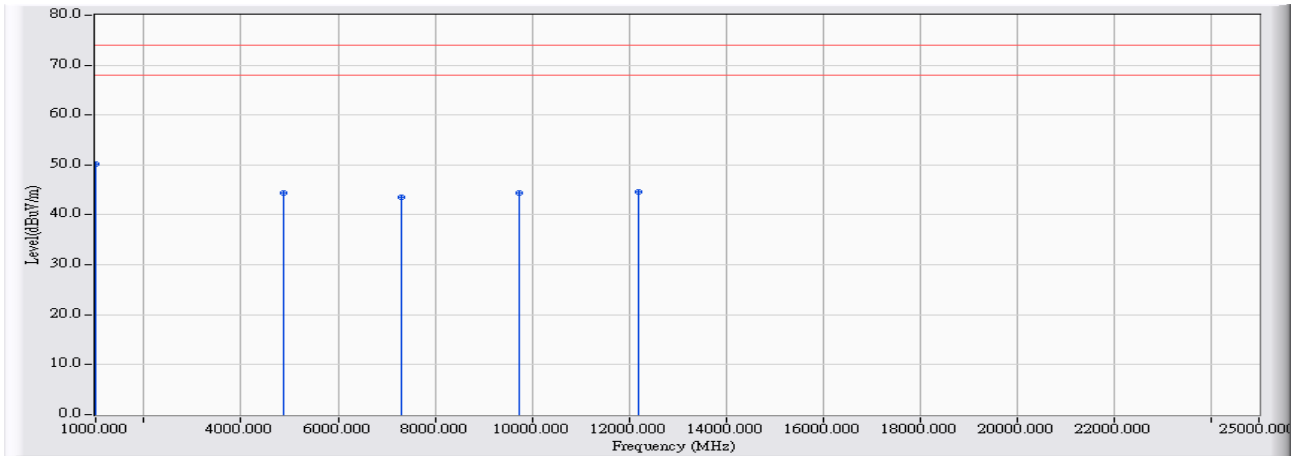

		Frequency (MHz)	Correct Factor (dB)	Reading Level (dBuV)	Measure Level (dBuV/m)	Margin (dB)	Peak Limit (dBuV/m)	Average Limit (dBuV/m)	Detector Type
1	*	1000.000	-7.776	57.992	50.216	-23.784	74.000	54.00	PEAK
2		4874.000	-1.042	45.366	44.324	-29.676	74.000	54.00	PEAK
3		7311.000	6.769	36.827	43.596	-30.404	74.000	54.00	PEAK
4		9748.000	8.165	36.230	44.395	-29.605	74.000	54.00	PEAK
5		12185.000	9.516	35.012	44.529	-29.471	74.000	54.00	PEAK

**Note:**

1. All readings above 1GHz are performed with peak and/or average measurements as necessary.
2. Peak measurements: RBW = 1MHz, VBW = 3 MHz, Sweep: Auto.
3. Average measurements: RBW = 1MHz, VBW = 10 Hz, Sweep: Auto.
4. “ \* ”, means this data is the worst emission level.
5. Measurement Level = Reading Level + Correct Factor.
6. The average measurement was not performed when the peak measured data under the limit of average detection.
7. The Emission above 13GHz were not included is because their levels are too low.

Site : CB1	Time : 2010/10/11 - 17:30
Limit : FCC_SpartC_15.247_H_03M_PK	Margin : 6
Probe : FCC_EFS_1-18G - HORIZONTAL	Power : AC 120V/60Hz
EUT : Wireless N Day/Night Home Network Camera	Note : Mode 1: Transmit (Adapter: AMS1-0501200FU)-802.11n(20M)-2462MHz

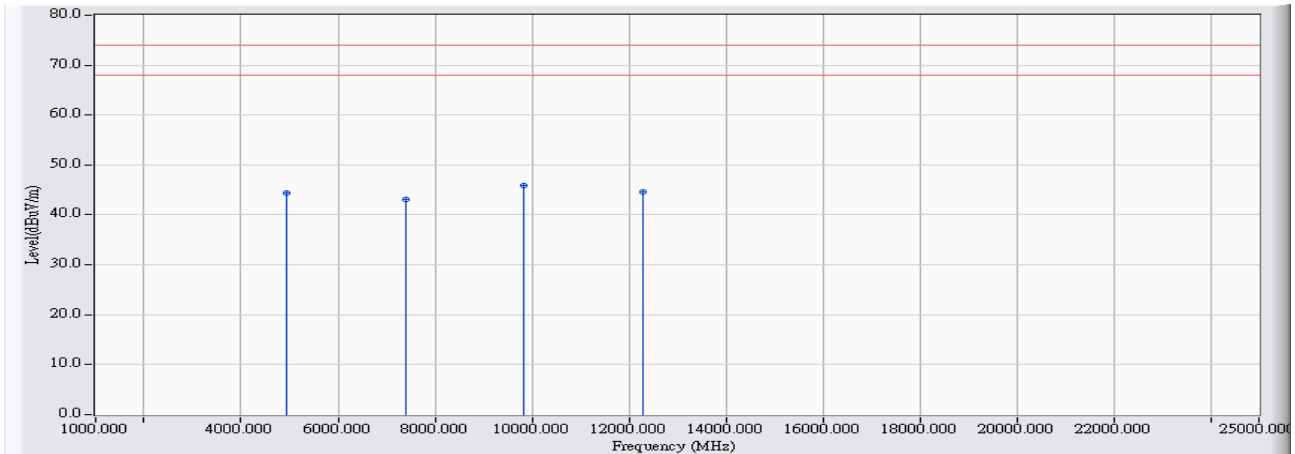

	Frequency (MHz)	Correct Factor (dB)	Reading Level (dBuV)	Measure Level (dBuV/m)	Margin (dB)	Peak Limit (dBuV/m)	Average Limit (dBuV/m)	Detector Type
1	4924.080	-0.545	44.940	44.395	-29.605	74.000	54.00	PEAK
2	7386.080	7.670	35.360	43.031	-30.969	74.000	54.00	PEAK
3	* 9836.830	8.278	37.520	45.798	-28.202	74.000	54.00	PEAK
4	12298.830	9.322	35.200	44.522	-29.478	74.000	54.00	PEAK

**Note:**

1. All readings above 1GHz are performed with peak and/or average measurements as necessary.
2. Peak measurements: RBW = 1MHz, VBW = 3 MHz, Sweep: Auto.
3. Average measurements: RBW = 1MHz, VBW = 10 Hz, Sweep: Auto.
4. “ \* ”, means this data is the worst emission level.
5. Measurement Level = Reading Level + Correct Factor.
6. The average measurement was not performed when the peak measured data under the limit of average detection.
7. The Emission above 13GHz were not included is because their levels are too low.

Site : CB1	Time : 2010/10/11 - 17:38
Limit : FCC_SpartC_15.247_H_03M_PK	Margin : 6
Probe : FCC_EFS_1-18G - VERTICAL	Power : AC 120V/60Hz
EUT : Wireless N Day/Night Home Network Camera	Note : Mode 1: Transmit (Adapter: AMS1-0501200FU)-802.11n(20M)-2462MHz

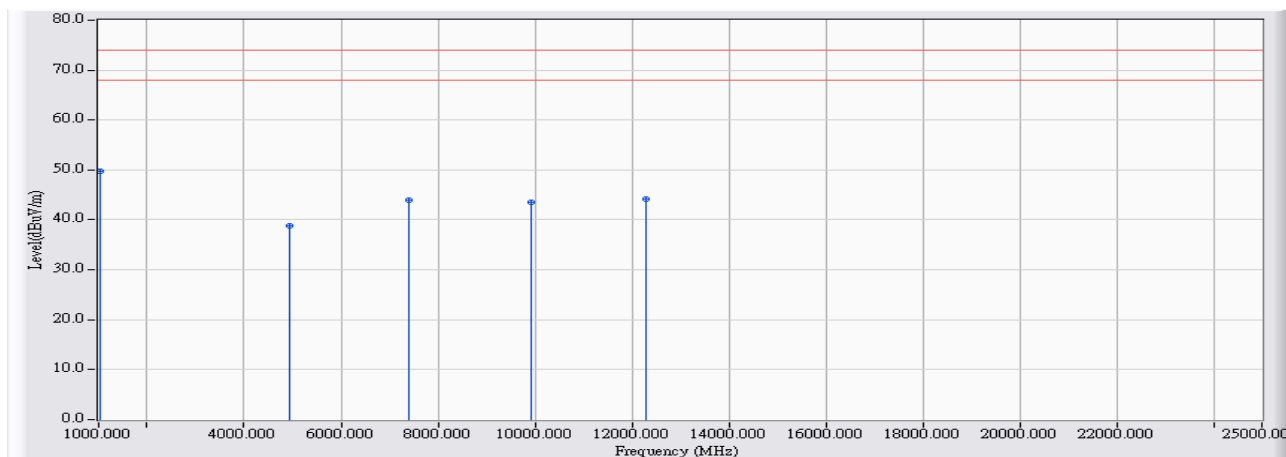

		Frequency (MHz)	Correct Factor (dB)	Reading Level (dBuV)	Measure Level (dBuV/m)	Margin (dB)	Peak Limit (dBuV/m)	Average Limit (dBuV/m)	Detector Type
1	*	1020.000	-7.881	57.590	49.709	-24.291	74.000	54.00	PEAK
2		4924.080	-0.533	39.390	38.856	-35.144	74.000	54.00	PEAK
3		7386.080	7.148	36.760	43.908	-30.092	74.000	54.00	PEAK
4		9936.380	8.217	35.300	43.518	-30.482	74.000	54.00	PEAK
5		12298.830	8.240	36.050	44.289	-29.711	74.000	54.00	PEAK

**Note:**

1. All readings above 1GHz are performed with peak and/or average measurements as necessary.
2. Peak measurements: RBW = 1MHz, VBW = 3 MHz, Sweep: Auto.
3. Average measurements: RBW = 1MHz, VBW = 10 Hz, Sweep: Auto.
4. “ \* ”, means this data is the worst emission level.
5. Measurement Level = Reading Level + Correct Factor.
6. The average measurement was not performed when the peak measured data under the limit of average detection.
7. The Emission above 13GHz were not included is because their levels are too low.

Site : CB1	Time : 2010/10/11 - 18:03
Limit : FCC_SpartC_15.247_H_03M_PK	Margin : 6
Probe : FCC_EFS_1-18G - HORIZONTAL	Power : AC 120V/60Hz
EUT : Wireless N Day/Night Home Network Camera	Note : Mode 1: Transmit (Adapter: AMS1-0501200FU)-802.11n(40M)-2422MHz

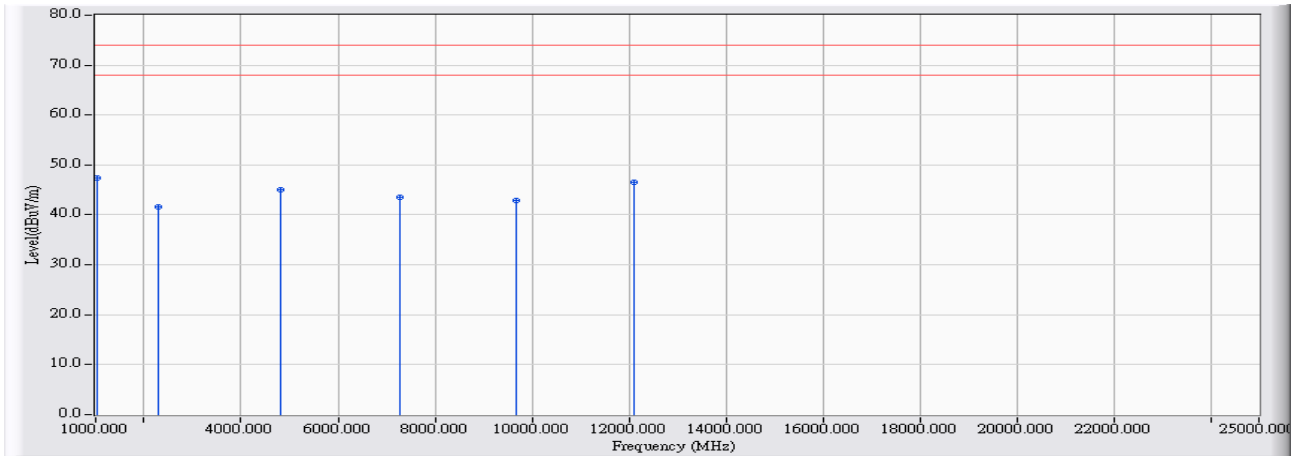

		Frequency (MHz)	Correct Factor (dB)	Reading Level (dBuV)	Measure Level (dBuV/m)	Margin (dB)	Peak Limit (dBuV/m)	Average Limit (dBuV/m)	Detector Type
1	*	1020.000	-9.967	57.440	47.473	-26.527	74.000	54.00	PEAK
2		2280.000	-9.967	51.630	41.663	-32.337	74.000	54.00	PEAK
3		4824.170	-0.732	45.740	45.007	-28.993	74.000	54.00	PEAK
4		7266.000	6.515	37.100	43.614	-30.386	74.000	54.00	PEAK
5		9688.000	7.715	35.280	42.994	-31.006	74.000	54.00	PEAK
6		12110.000	10.829	35.710	46.539	-27.461	74.000	54.00	PEAK

Note:

1. All readings above 1GHz are performed with peak and/or average measurements as necessary.
2. Peak measurements: RBW = 1MHz, VBW = 3 MHz, Sweep: Auto.
3. Average measurements: RBW = 1MHz, VBW = 10 Hz, Sweep: Auto.
4. “ \* ”, means this data is the worst emission level.
5. Measurement Level = Reading Level + Correct Factor.
6. The average measurement was not performed when the peak measured data under the limit of average detection.
7. The Emission above 13GHz were not included is because their levels are too low.

Site : CB1	Time : 2010/10/11 - 18:09
Limit : FCC_SpartC_15.247_H_03M_PK	Margin : 6
Probe : FCC_EFS_1-18G - VERTICAL	Power : AC 120V/60Hz
EUT : Wireless N Day/Night Home Network Camera	Note : Mode 1: Transmit (Adapter: AMS1-0501200FU)-802.11n(40M)-2422MHz

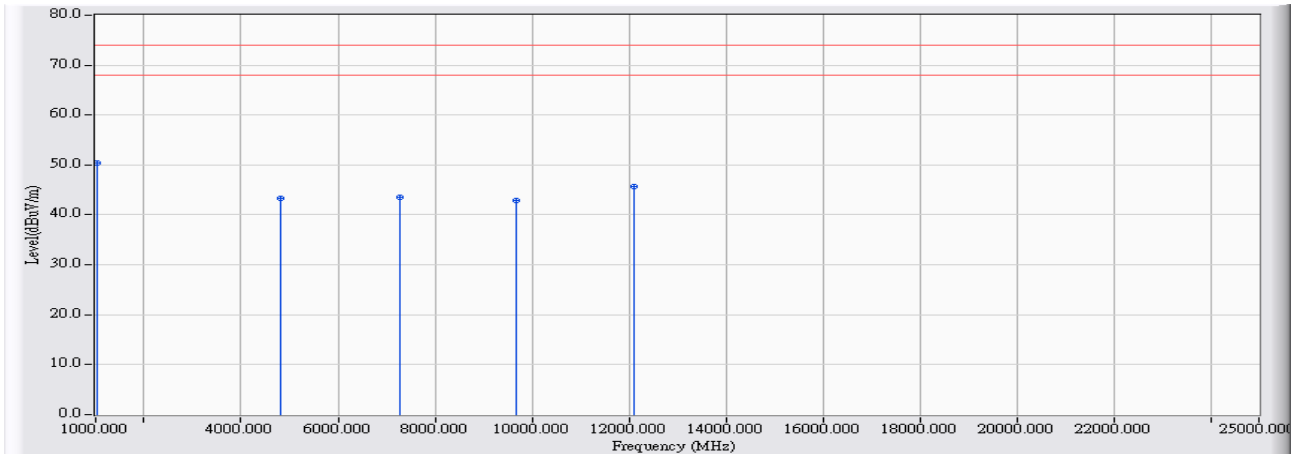

		Frequency (MHz)	Correct Factor (dB)	Reading Level (dBuV)	Measure Level (dBuV/m)	Margin (dB)	Peak Limit (dBuV/m)	Average Limit (dBuV/m)	Detector Type
1	*	1020.000	-7.881	58.250	50.369	-23.631	74.000	54.00	PEAK
2		4820.000	-0.849	44.080	43.231	-30.769	74.000	54.00	PEAK
3		7266.000	6.478	36.970	43.448	-30.552	74.000	54.00	PEAK
4		9688.000	7.916	34.920	42.836	-31.164	74.000	54.00	PEAK
5		12110.000	9.725	35.910	45.636	-28.364	74.000	54.00	PEAK

**Note:**

1. All readings above 1GHz are performed with peak and/or average measurements as necessary.
2. Peak measurements: RBW = 1MHz, VBW = 3 MHz, Sweep: Auto.
3. Average measurements: RBW = 1MHz, VBW = 10 Hz, Sweep: Auto.
4. “ \* ”, means this data is the worst emission level.
5. Measurement Level = Reading Level + Correct Factor.
6. The average measurement was not performed when the peak measured data under the limit of average detection.
7. The Emission above 13GHz were not included is because their levels are too low.

Site : CB1	Time : 2010/10/15 - 17:32
Limit : FCC_SpartC_15.247_H_03M_PK	Margin : 6
Probe : FCC_EFS_1-18G - HORIZONTAL	Power : AC 120V/60Hz
EUT: Wireless N Day/Night Home Network Camera	Note : Mode 1: Transmit (Adapter: AMS1-0501200FU)-802.11n(40M)-2437MHz

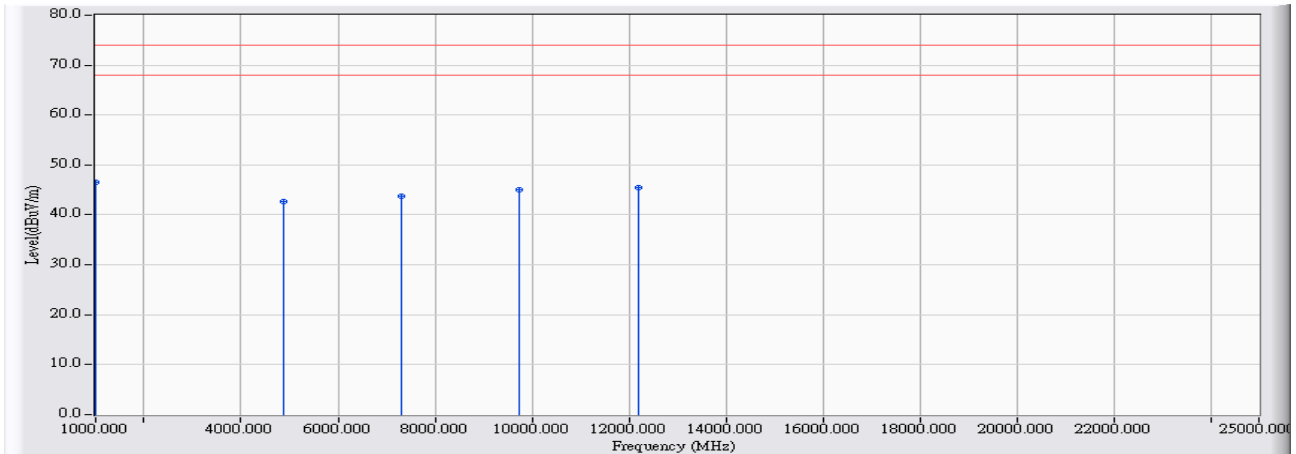

		Frequency (MHz)	Correct Factor (dB)	Reading Level (dBuV)	Measure Level (dBuV/m)	Margin (dB)	Peak Limit (dBuV/m)	Average Limit (dBuV/m)	Detector Type
1	*	1000.000	-9.746	56.281	46.535	-27.465	74.000	54.00	PEAK
2		4874.000	-1.003	43.756	42.754	-31.246	74.000	54.00	PEAK
3		7311.000	6.988	36.790	43.778	-30.222	74.000	54.00	PEAK
4		9748.000	8.007	37.119	45.126	-28.874	74.000	54.00	PEAK
5		12185.000	10.601	34.819	45.421	-28.579	74.000	54.00	PEAK

**Note:**

1. All readings above 1GHz are performed with peak and/or average measurements as necessary.
2. Peak measurements: RBW = 1MHz, VBW = 3 MHz, Sweep: Auto.
3. Average measurements: RBW = 1MHz, VBW = 10 Hz, Sweep: Auto.
4. “ \* ”, means this data is the worst emission level.
5. Measurement Level = Reading Level + Correct Factor.
6. The average measurement was not performed when the peak measured data under the limit of average detection.
7. The Emission above 13GHz were not included is because their levels are too low.

Site : CB1	Time : 2010/10/15 - 17:37
Limit : FCC_SpartC_15.247_H_03M_PK	Margin : 6
Probe : FCC_EFS_1-18G - VERTICAL	Power : AC 120V/60Hz
EUT: Wireless N Day/Night Home Network Camera	Note : Mode 1: Transmit (Adapter: AMS1-0501200FU)-802.11n(40M)-2437MHz

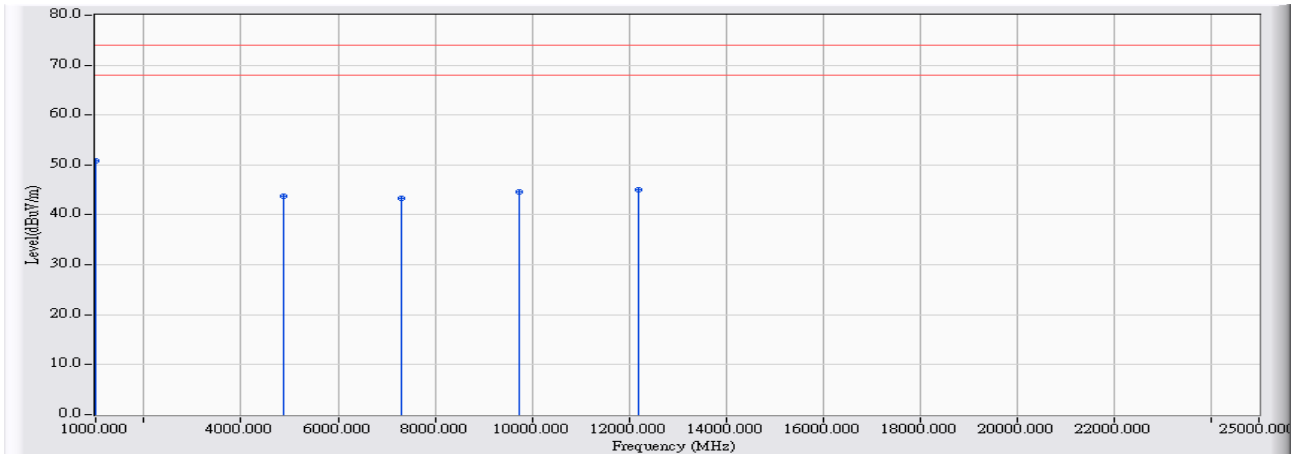

		Frequency (MHz)	Correct Factor (dB)	Reading Level (dBuV)	Measure Level (dBuV/m)	Margin (dB)	Peak Limit (dBuV/m)	Average Limit (dBuV/m)	Detector Type
1	*	1000.000	-7.776	58.657	50.881	-23.119	74.000	54.00	PEAK
2		4874.000	-1.042	44.792	43.750	-30.250	74.000	54.00	PEAK
3		7311.000	6.769	36.622	43.391	-30.609	74.000	54.00	PEAK
4		9748.000	8.165	36.449	44.614	-29.386	74.000	54.00	PEAK
5		12185.000	9.516	35.509	45.026	-28.974	74.000	54.00	PEAK

**Note:**

1. All readings above 1GHz are performed with peak and/or average measurements as necessary.
2. Peak measurements: RBW = 1MHz, VBW = 3 MHz, Sweep: Auto.
3. Average measurements: RBW = 1MHz, VBW = 10 Hz, Sweep: Auto.
4. " \* ", means this data is the worst emission level.
5. Measurement Level = Reading Level + Correct Factor.
6. The average measurement was not performed when the peak measured data under the limit of average detection.
7. The Emission above 13GHz were not included is because their levels are too low.

Site : CB1	Time : 2010/10/11 - 18:35
Limit : FCC_SpartC_15.247_H_03M_PK	Margin : 6
Probe : FCC_EFS_1-18G - HORIZONTAL	Power : AC 120V/60Hz
EUT : Wireless N Day/Night Home Network Camera	Note : Mode 1: Transmit (Adapter: AMS1-0501200FU)-802.11n(40M)-2452MHz

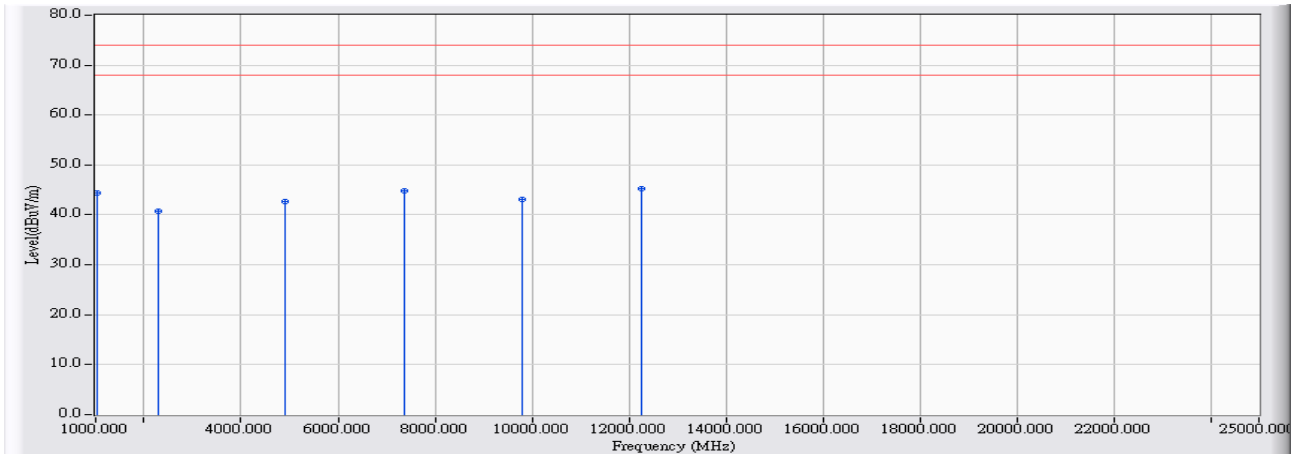

	Frequency (MHz)	Correct Factor (dB)	Reading Level (dBuV)	Measure Level (dBuV/m)	Margin (dB)	Peak Limit (dBuV/m)	Average Limit (dBuV/m)	Detector Type
1	1020.000	-9.967	54.310	44.343	-29.657	74.000	54.00	PEAK
2	2280.000	-9.967	50.710	40.743	-33.257	74.000	54.00	PEAK
3	4904.000	-0.748	43.500	42.751	-31.249	74.000	54.00	PEAK
4	7356.000	7.498	37.230	44.728	-29.272	74.000	54.00	PEAK
5	9808.000	7.923	35.270	43.193	-30.807	74.000	54.00	PEAK
6	* 12260.000	9.605	35.720	45.324	-28.676	74.000	54.00	PEAK

**Note:**

1. All readings above 1GHz are performed with peak and/or average measurements as necessary.
2. Peak measurements: RBW = 1MHz, VBW = 3 MHz, Sweep: Auto.
3. Average measurements: RBW = 1MHz, VBW = 10 Hz, Sweep: Auto.
4. “ \* ”, means this data is the worst emission level.
5. Measurement Level = Reading Level + Correct Factor.
6. The average measurement was not performed when the peak measured data under the limit of average detection.
7. The Emission above 13GHz were not included is because their levels are too low.



Site : CB1	Time : 2010/10/11 - 18:41
Limit : FCC_SpartC_15.247_H_03M_PK	Margin : 6
Probe : FCC_EFS_1-18G - VERTICAL	Power : AC 120V/60Hz
EUT : Wireless N Day/Night Home Network Camera	Note : Mode 1: Transmit (Adapter: AMS1-0501200FU)-802.11n(40M)-2452MHz

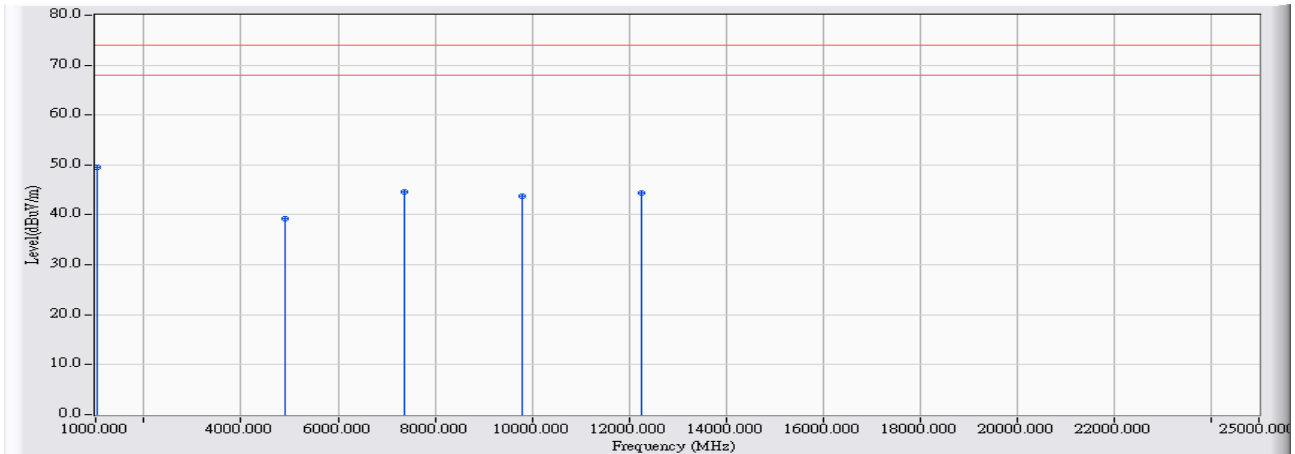

		Frequency (MHz)	Correct Factor (dB)	Reading Level (dBuV)	Measure Level (dBuV/m)	Margin (dB)	Peak Limit (dBuV/m)	Average Limit (dBuV/m)	Detector Type
1	*	1020.000	-7.881	57.370	49.489	-24.511	74.000	54.00	PEAK
2		4904.000	-0.766	40.010	39.244	-34.756	74.000	54.00	PEAK
3		7356.000	7.087	37.570	44.658	-29.342	74.000	54.00	PEAK
4		9808.000	8.047	35.790	43.837	-30.163	74.000	54.00	PEAK
5		12260.000	8.521	35.800	44.321	-29.679	74.000	54.00	PEAK

**Note:**

1. All readings above 1GHz are performed with peak and/or average measurements as necessary.
2. Peak measurements: RBW = 1MHz, VBW = 3 MHz, Sweep: Auto.
3. Average measurements: RBW = 1MHz, VBW = 10 Hz, Sweep: Auto.
4. “ \* ”, means this data is the worst emission level.
5. Measurement Level = Reading Level + Correct Factor.
6. The average measurement was not performed when the peak measured data under the limit of average detection.
7. The Emission above 13GHz were not included is because their levels are too low.

**5. RF antenna conducted test**

**5.1. Test Equipment**

The following test equipment is used during the test:

**RF antenna conducted test / SR7**

Instrument	Manufacturer	Model No.	Serial No	Next Cal. Date
Spectrum Analyzer	R&S	FSP	100561	2011/02/04

Note: 1. All equipments that need to calibrate are with calibration period of 1 year.

**5.2. Test Setup**

RF Antenna Conducted Measurement:

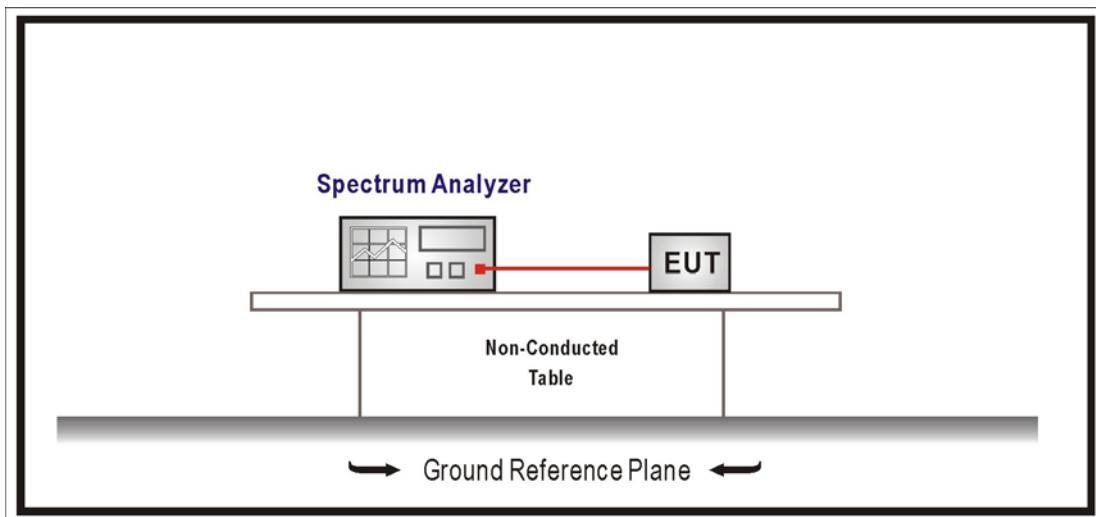

### 5.3. Limits

In any 100 kHz bandwidth outside the frequency band in which the spread spectrum intentional radiator is operating, the radio frequency power that is produced by the intentional radiator shall be at least 20 dB below that in the 100 kHz bandwidth within the band that contains the highest level of the desired power, based on an RF conducted or radiated measurement. Attenuation below the general limits specified in Section 15.209(a) is not required. In addition, radiated emissions which fall in the restricted bands, as defined in Section 15.205(a), must also comply with the radiated emission limits specified in Section 15.209(a) (see Section 15.205(c)).

### 5.4. Test Procedure

The EUT was setup according to ANSI C63.4: 2009 and tested according to DTS test procedure of Oct 2002 KDB558074 for compliance to FCC 47CFR 15.247 requirements Set RBW = 100 kHz, Set VBW > RBW, scan up through 10th harmonic.

### 5.5. Test Specification

According to FCC Part 15 Subpart C Paragraph 15.247: 2009

### 5.6. Uncertainty

Conducted is defined as  $\pm 1.27\text{dB}$

## 5.7. Test Result

Product	Wireless N Day/Night Home Network Camera		
Test Item	RF antenna conducted test		
Test Mode	Transmit		
Date of Test	2010/10/15	Test Site	SR7

IEEE 802.11b, Antenna Gain: 2.1dBi Duty Cycle: 1				
Channel No.	Frequency (MHz)	Measure Level (dBc)	Limit (dBc)	Result
1	2412	44.14	$\leq 20$	Pass
11	2462	53.39	$\leq 20$	Pass

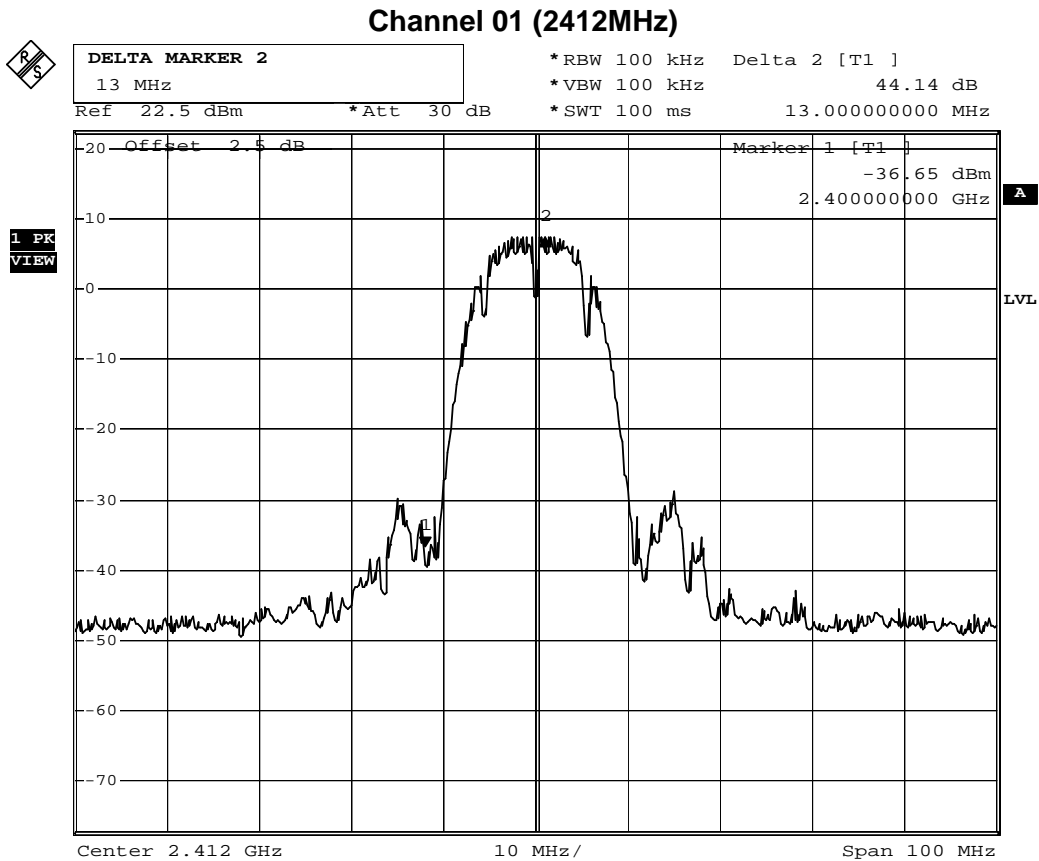

Date: 15.OCT.2010 11:51:54

Channel 11 (2462MHz)

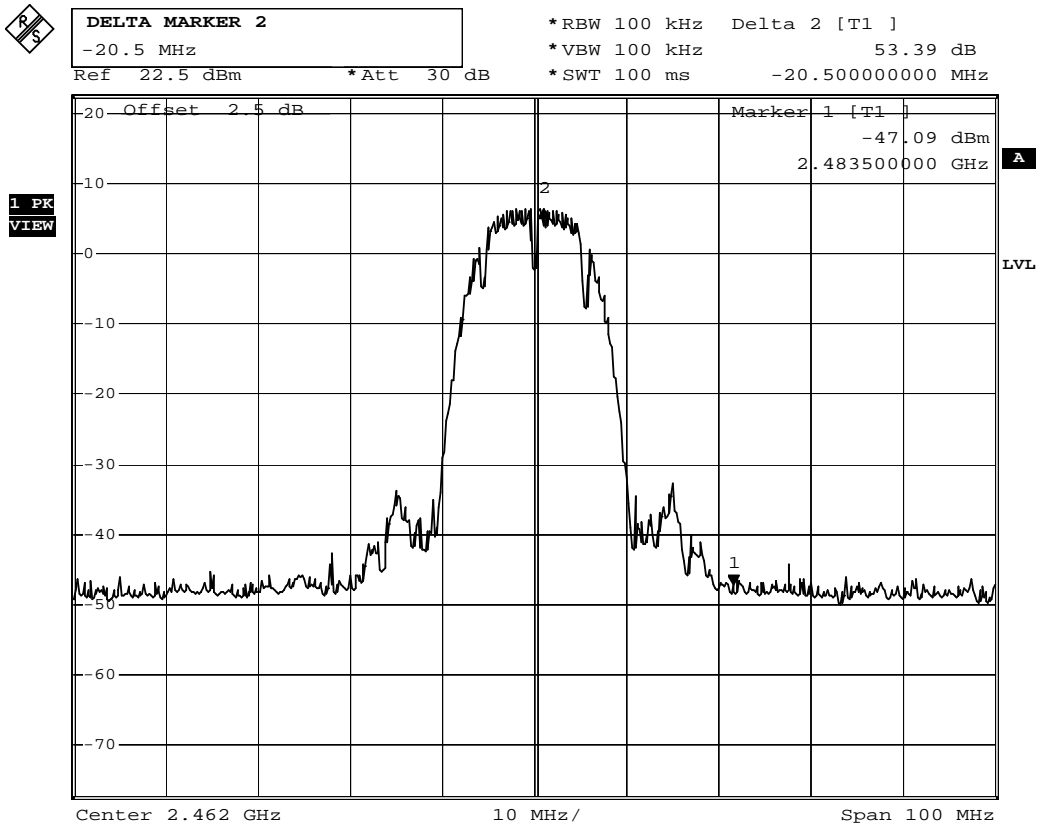

Date: 15.OCT.2010 11:56:32

Product	Wireless N Day/Night Home Network Camera		
Test Item	RF antenna conducted test		
Test Mode	Transmit		
Date of Test	2010/10/15	Test Site	SR7

IEEE 802.11g, Antenna Gain: 2.1dBi Duty Cycle: 1				
Channel No.	Frequency (MHz)	Measure Level (dBc)	Limit (dBc)	Result
1	2412	31.21	$\geq 20$	Pass
11	2462	46.98	$\geq 20$	Pass

### Channel 01 (2412MHz)

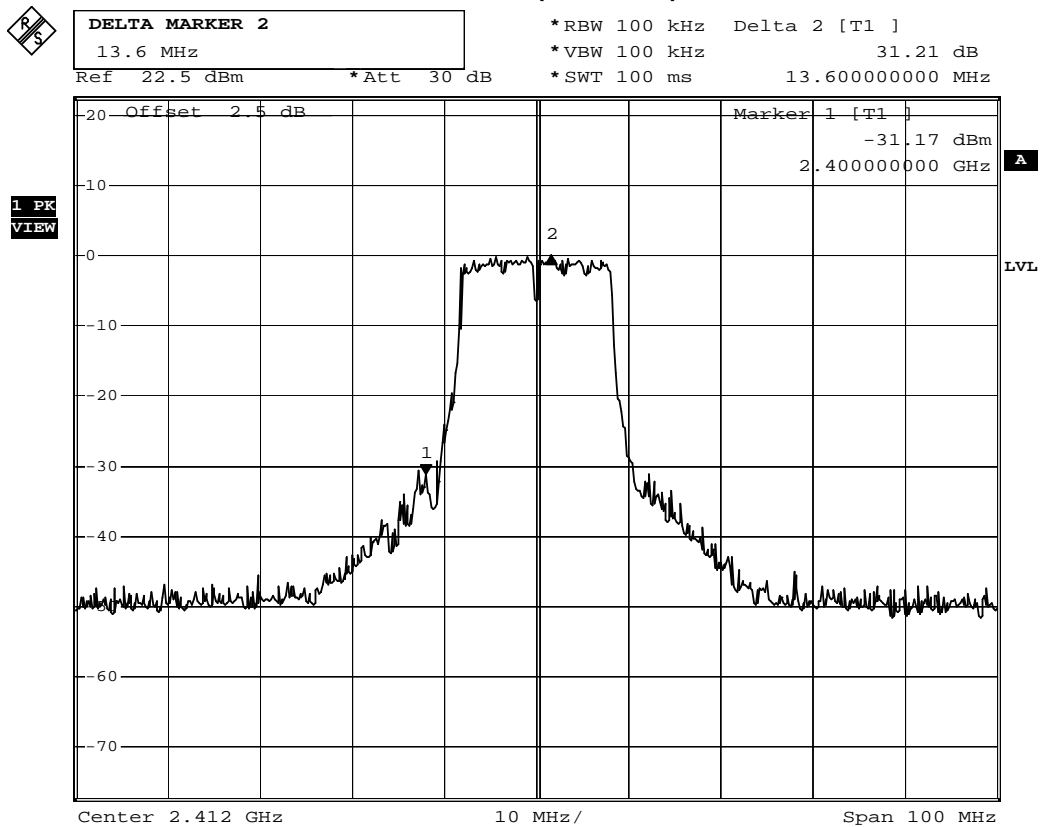

Date: 15.OCT.2010 15:42:43

Channel 11 (2462MHz)

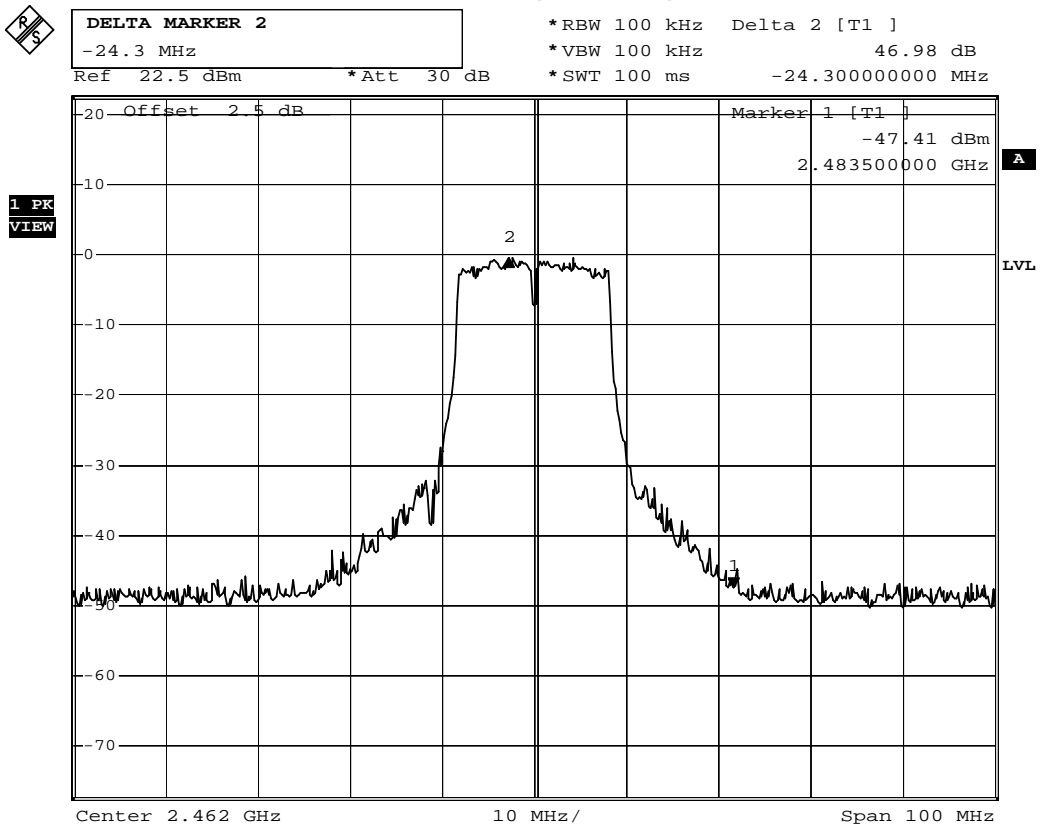

Date: 15.OCT.2010 15:43:51

Product	Wireless N Day/Night Home Network Camera		
Test Item	RF antenna conducted test		
Test Mode	Transmit		
Date of Test	2010/10/15	Test Site	SR7

IEEE 802.11n (20MHz), Antenna Gain: 2.1dBi Duty Cycle: 1				
Channel No.	Frequency (MHz)	Measure Level (dBc)	Limit (dBc)	Result
1	2412	35.22	≥20	Pass
11	2462	44.47	≥20	Pass

### Channel 1 (2412MHz)

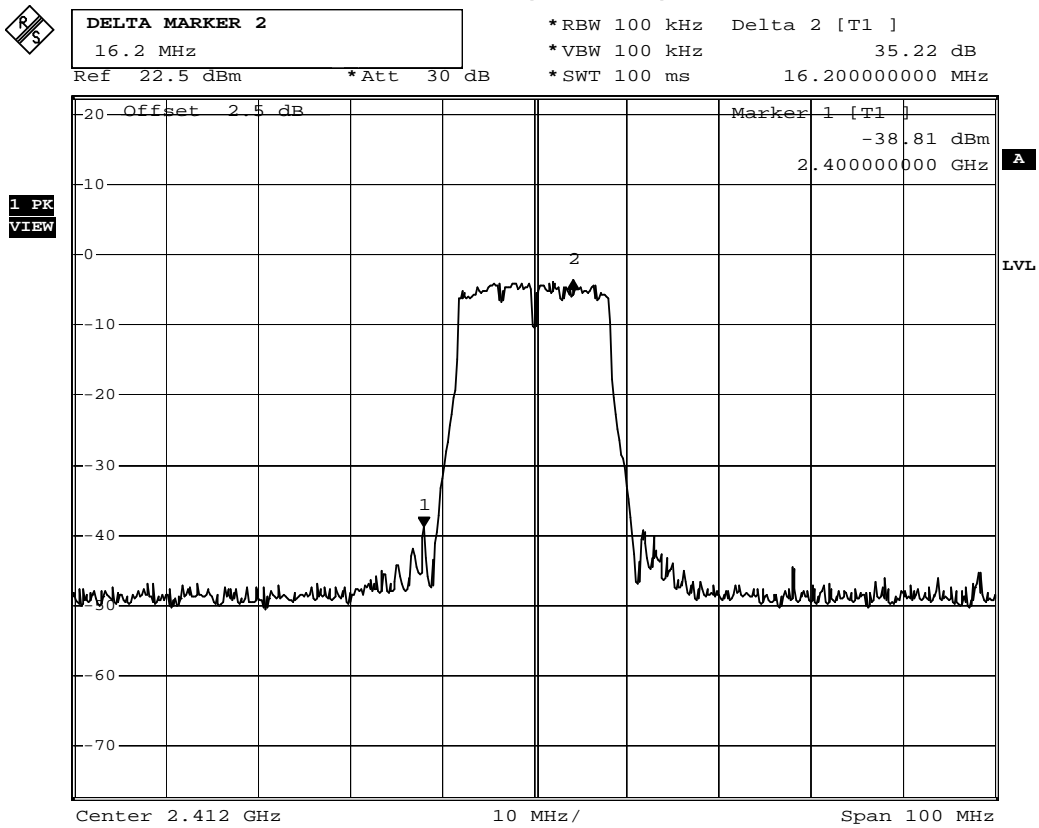

Date: 15.OCT.2010 15:45:01



Channel 11 (2462MHz)

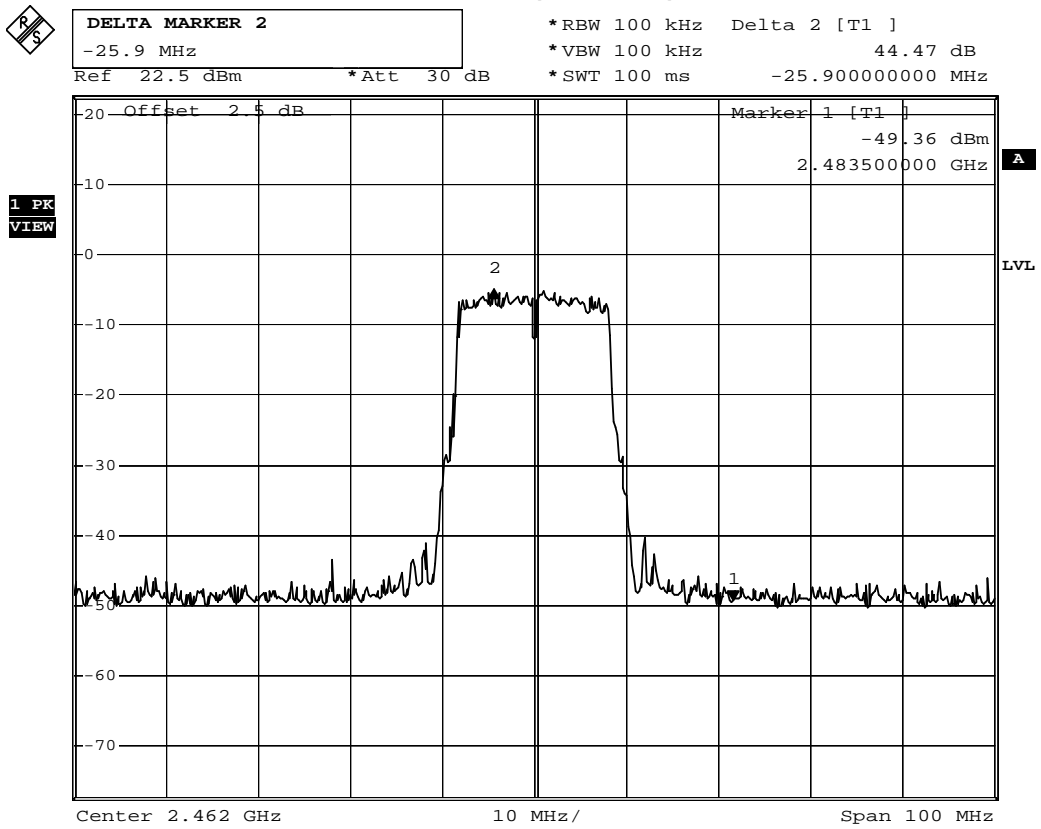

Date: 15.OCT.2010 15:46:06

Product	Wireless N Day/Night Home Network Camera		
Test Item	RF antenna conducted test		
Test Mode	Transmit		
Date of Test	2010/10/15	Test Site	SR7

IEEE 802.11n (40MHz), Antenna Gain: 2.1dBi Duty Cycle: 1				
Channel No.	Frequency (MHz)	Measure Level (dBc)	Limit (dBc)	Result
3	2422	27.21	≥20	Pass
9	2452	41.27	≥20	Pass

### Channel 3 (2422MHz)

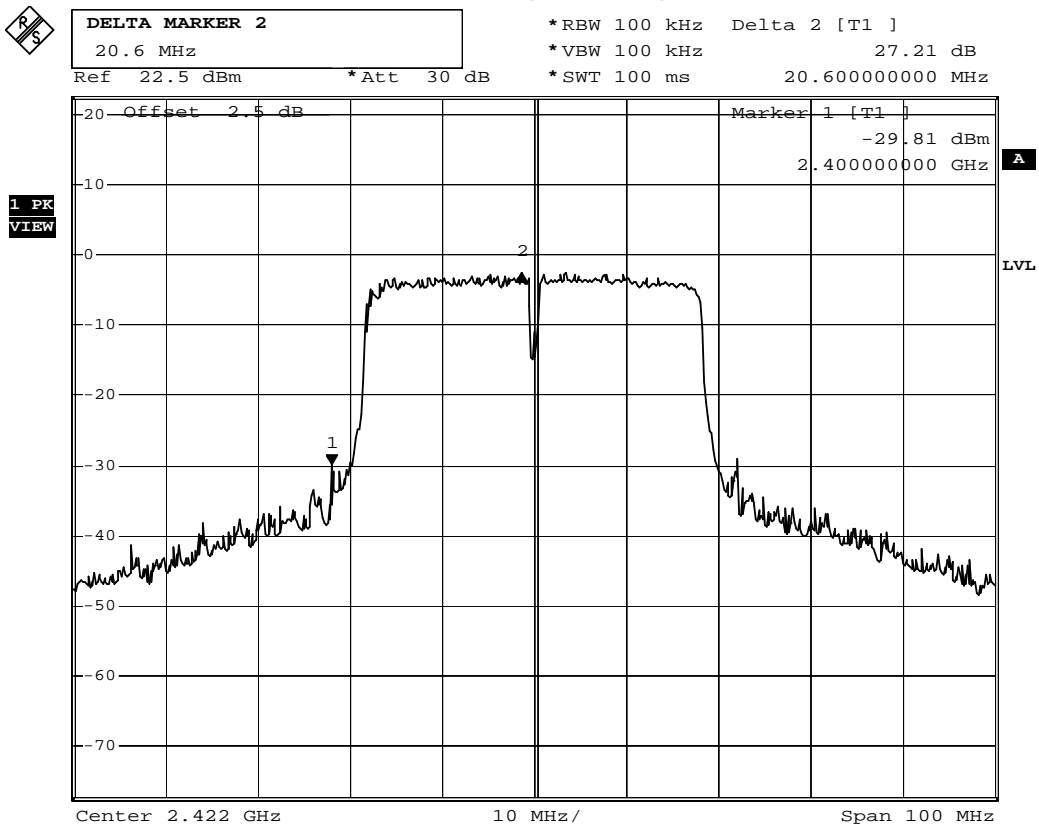

Date: 15.OCT.2010 13:19:58

Channel 9 (2452MHz)

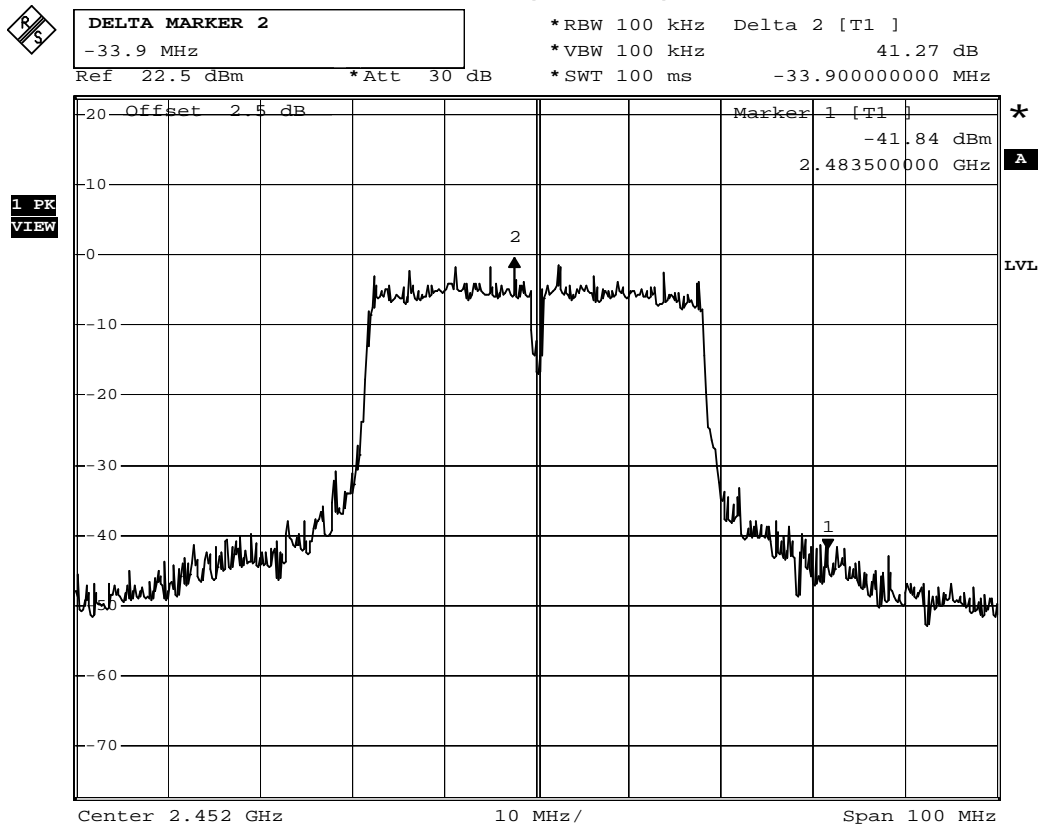

Date: 15.OCT.2010 13:47:08

Product	Wireless N Day/Night Home Network Camera		
Test Item	RF antenna conducted test		
Test Mode	Transmit		
Date of Test	2011/01/17	Test Site	SR7

### 2412MHz (30MHz-1GHz)-B

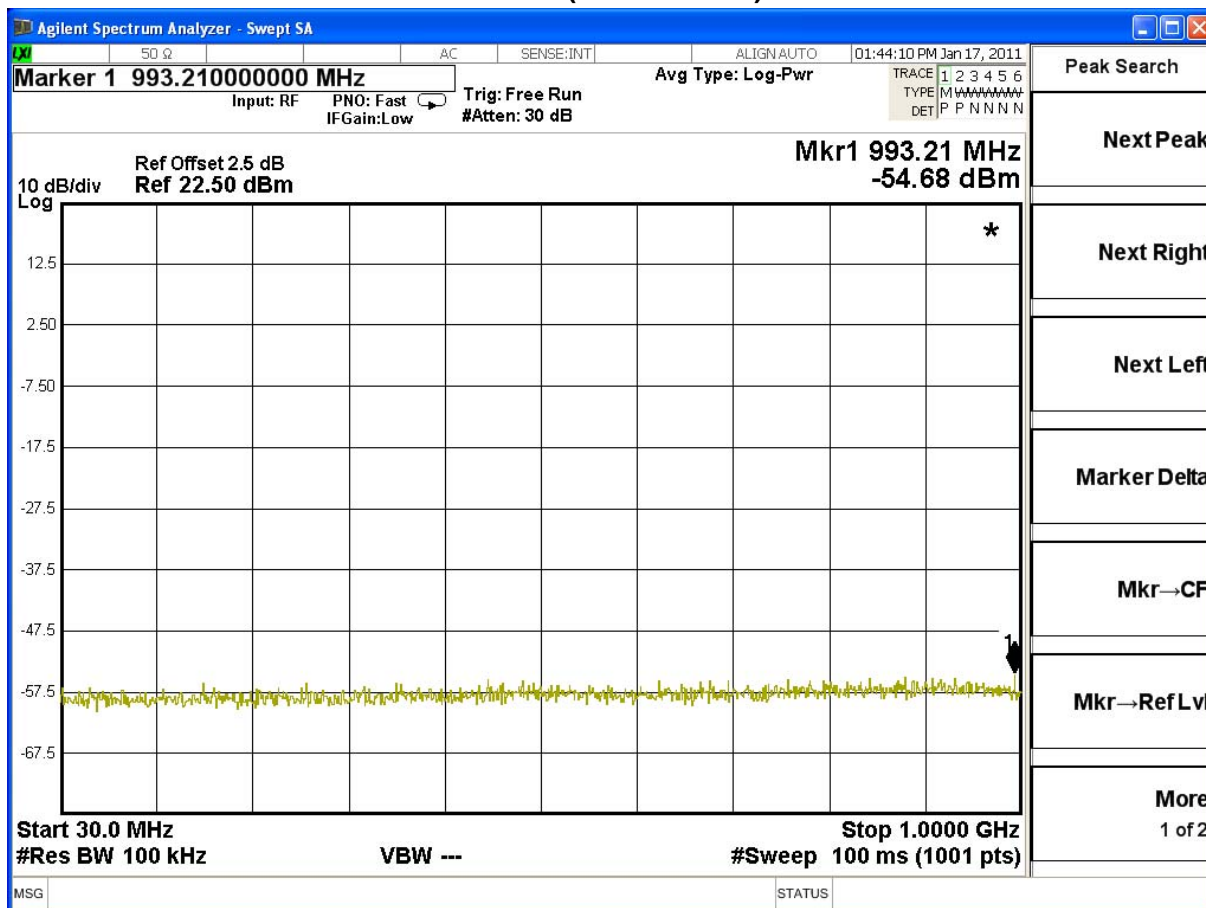

2412MHz (1GHz-8GHz)-B

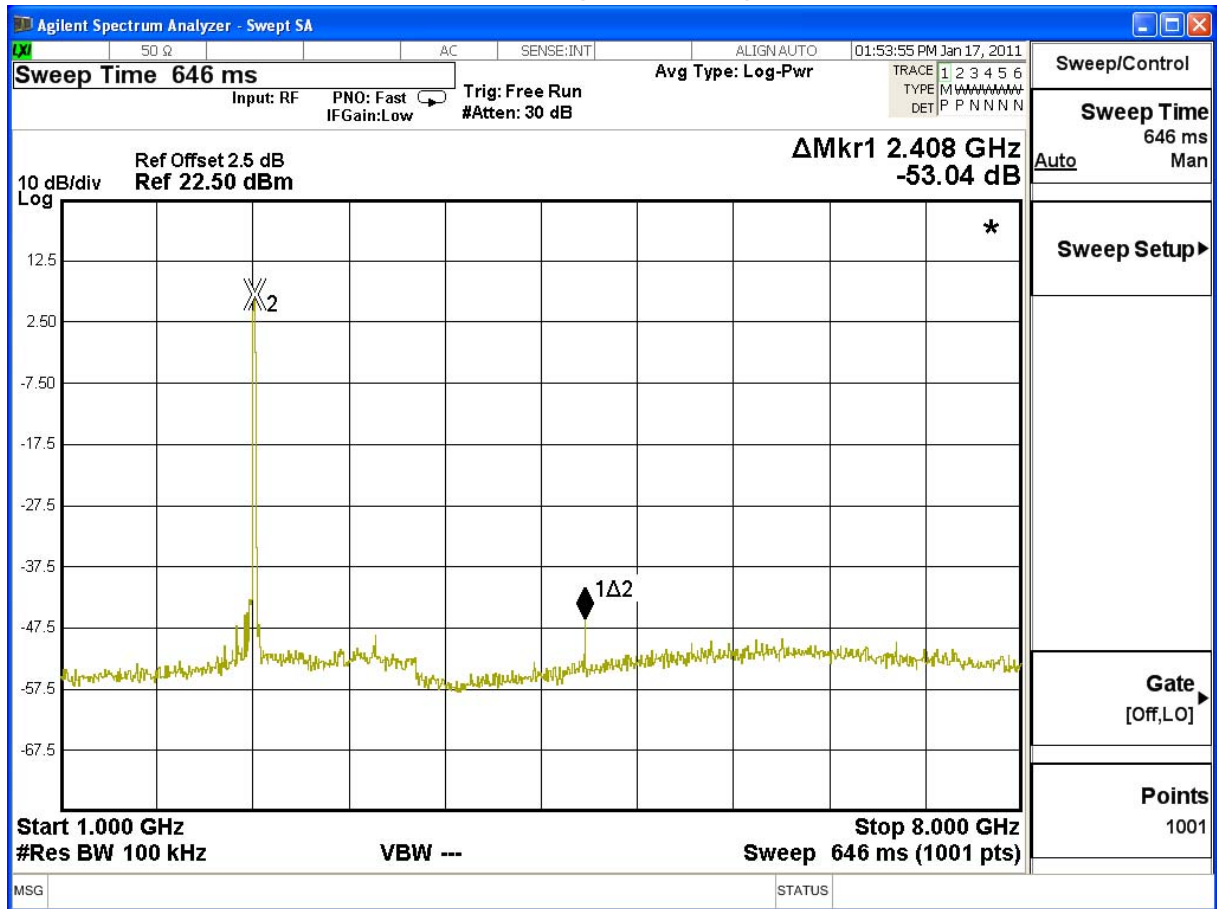

2412MHz (8GHz-16GHz)-B

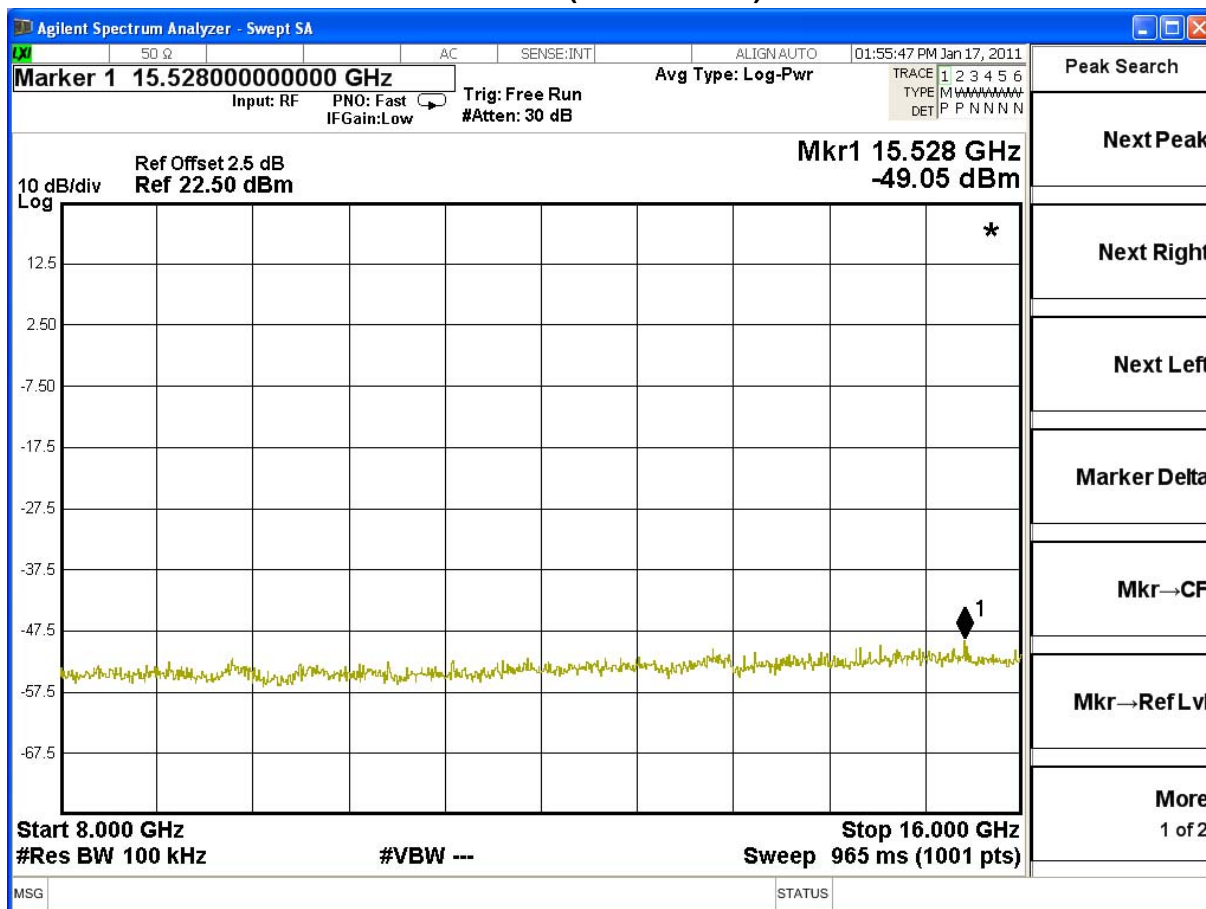

2412MHz (16GHz-25GHz)-B

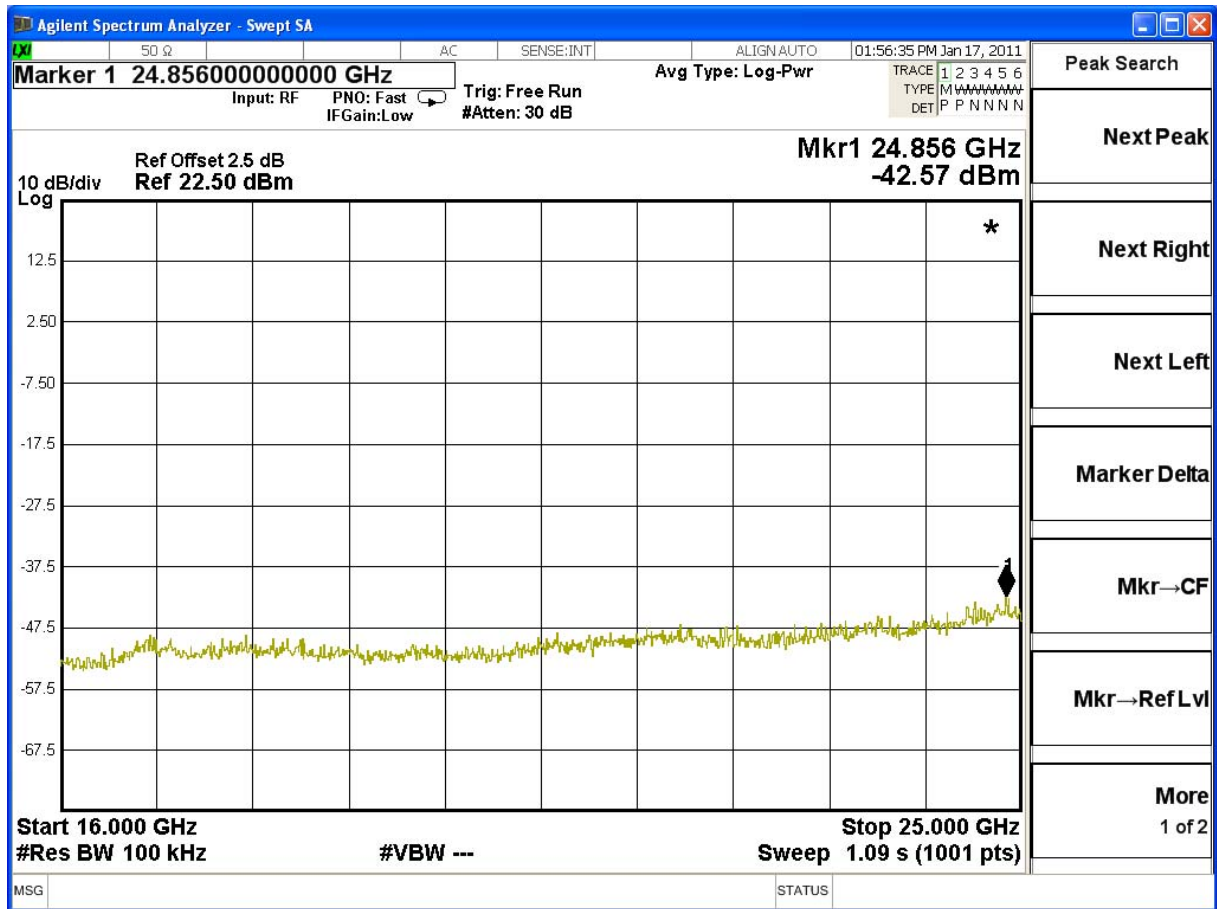





2437MHz (1GHz-8GHz)-B

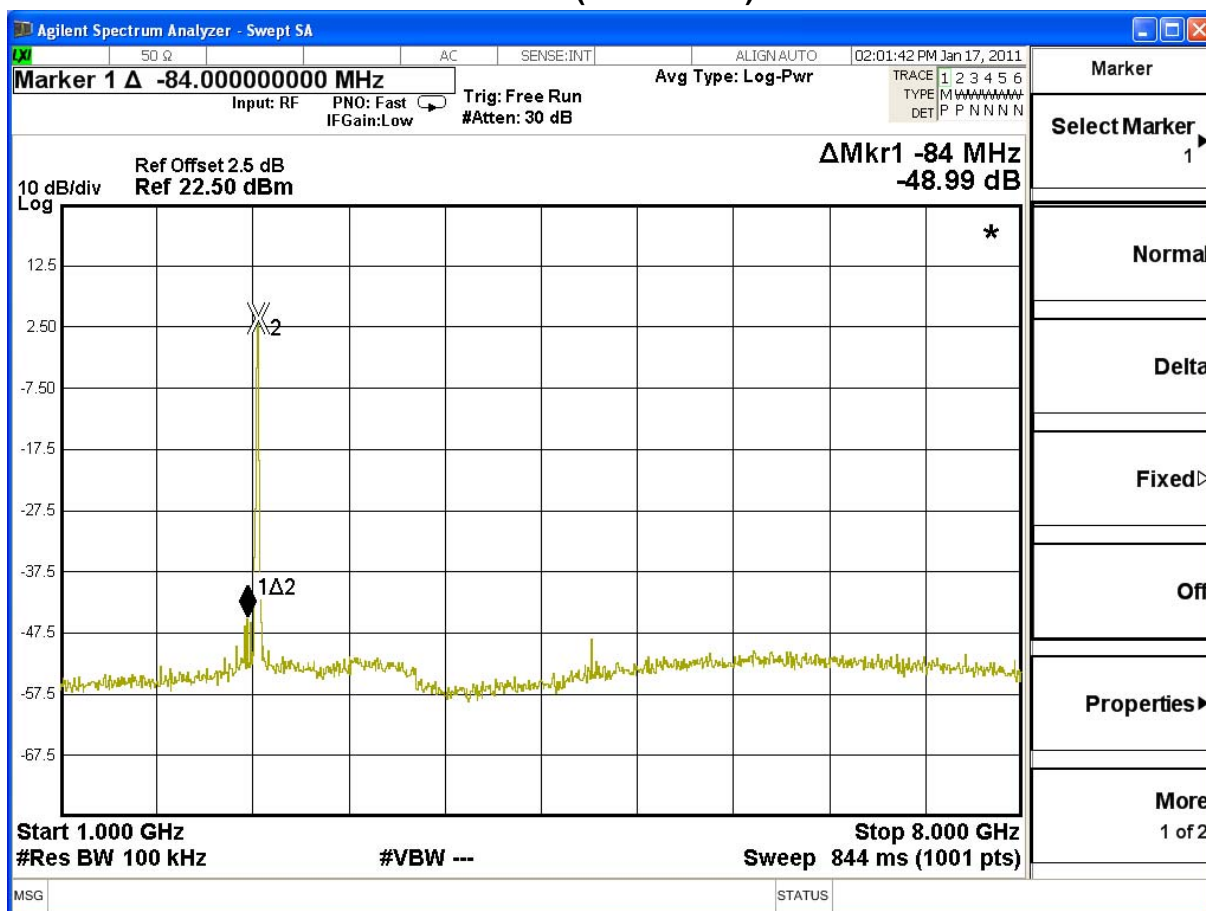

2437MHz (8GHz-16GHz)-B

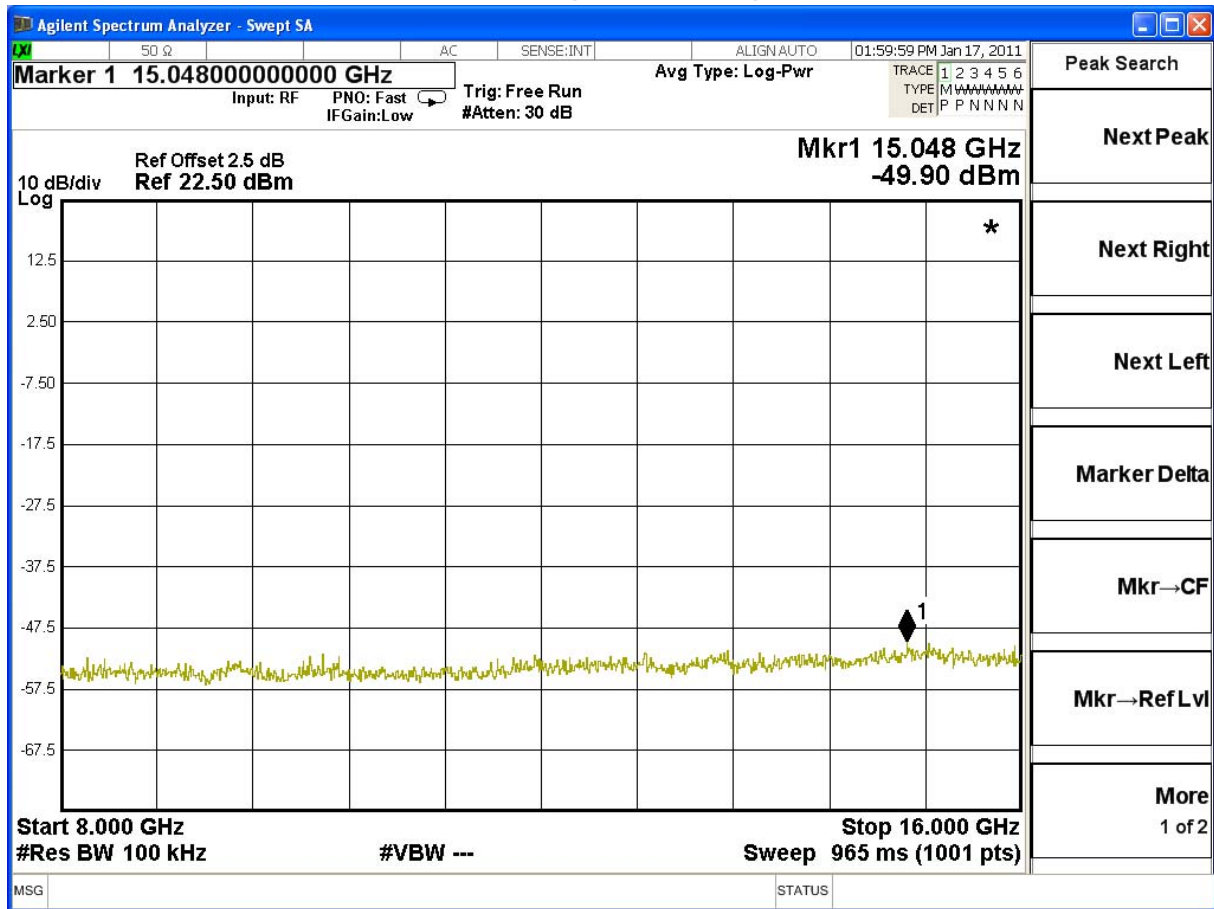

2437MHz (16GHz-25GHz)-B

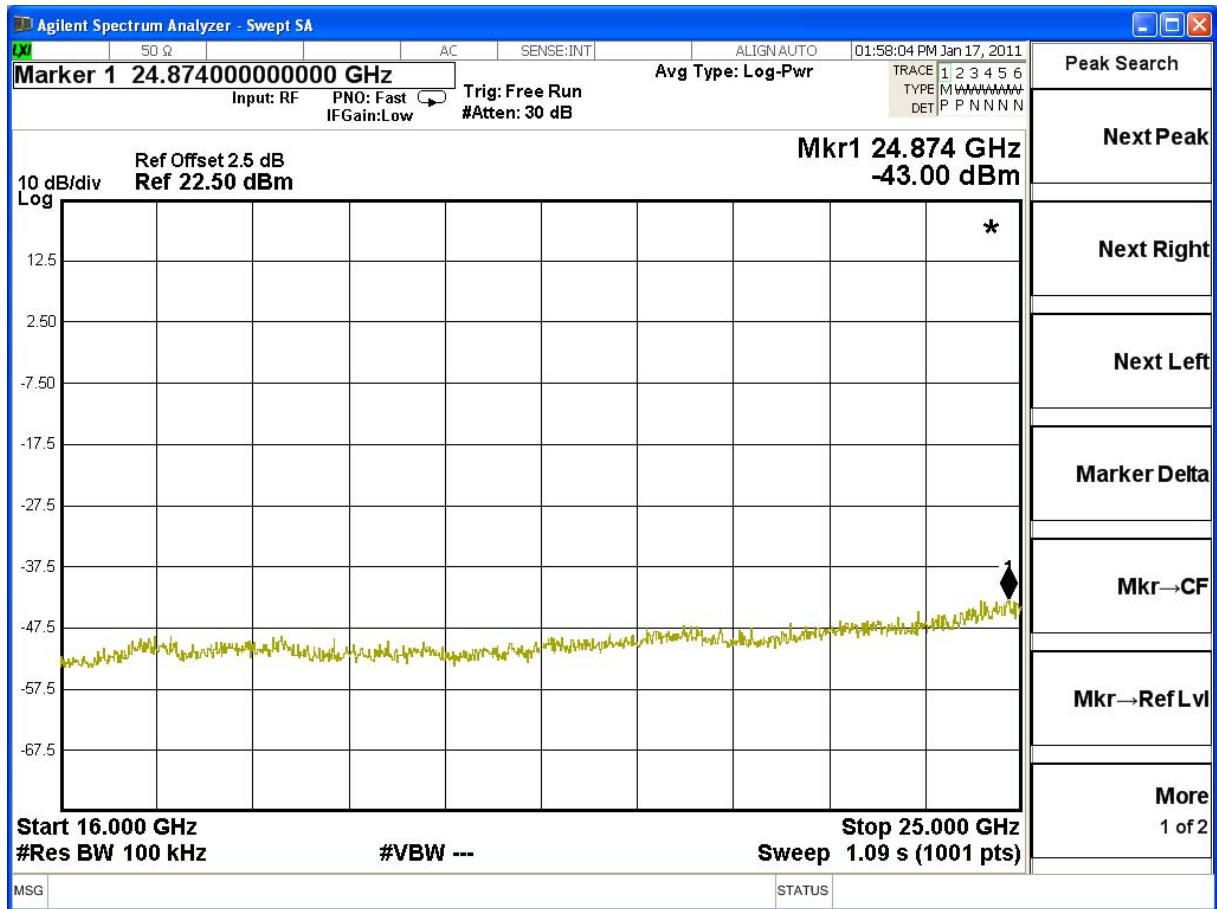

2462MHz (30MHz-1GHz)-B

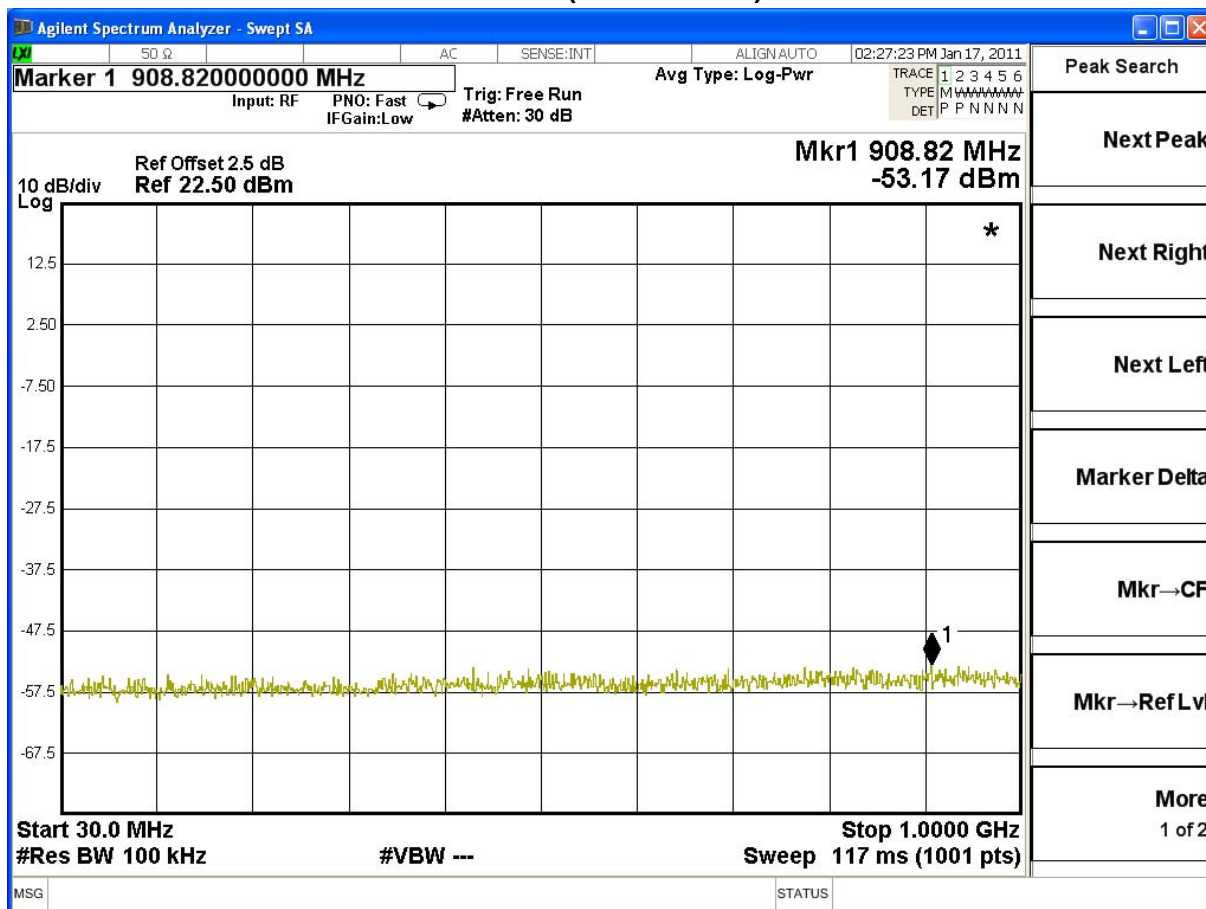

2462MHz (1GHz-8GHz)-B

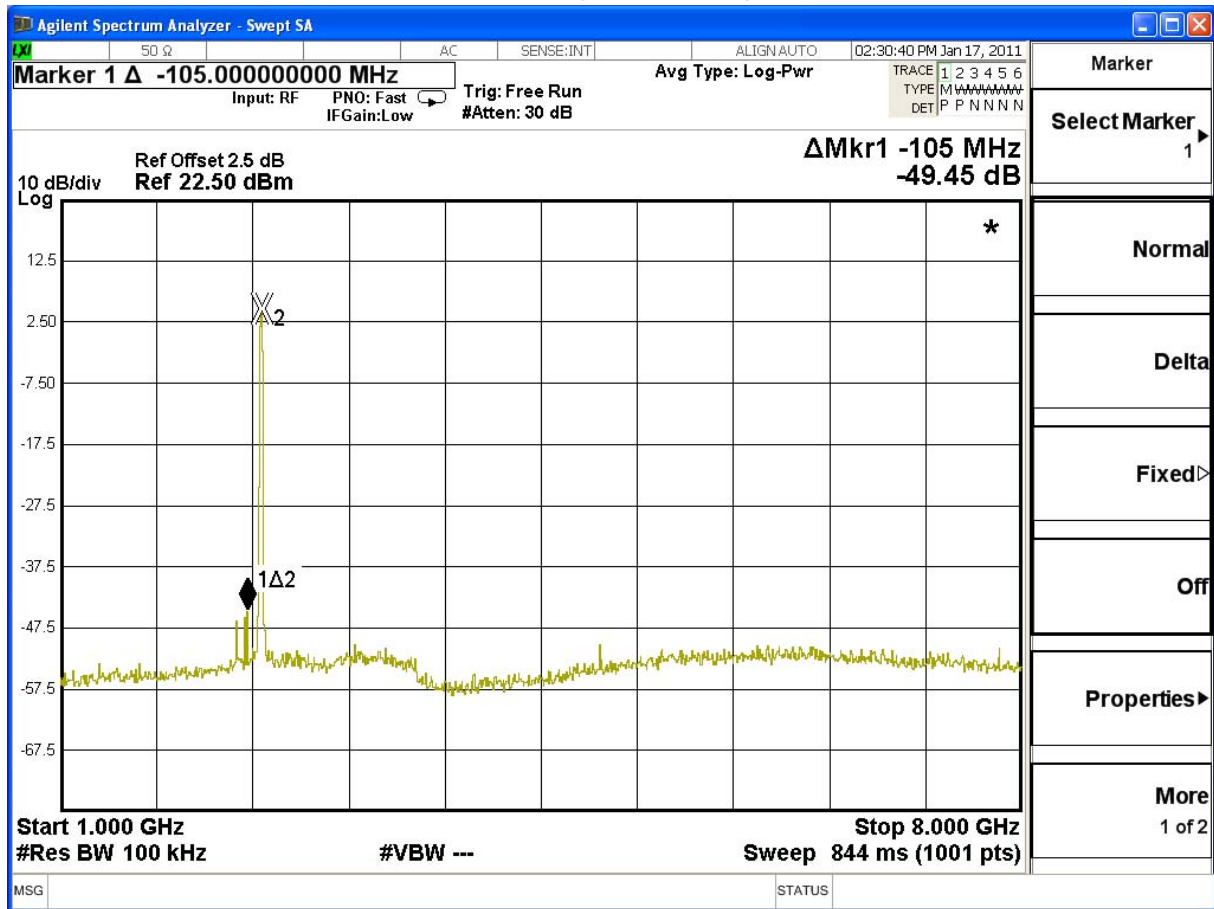



2462MHz (16GHz-25GHz)-B

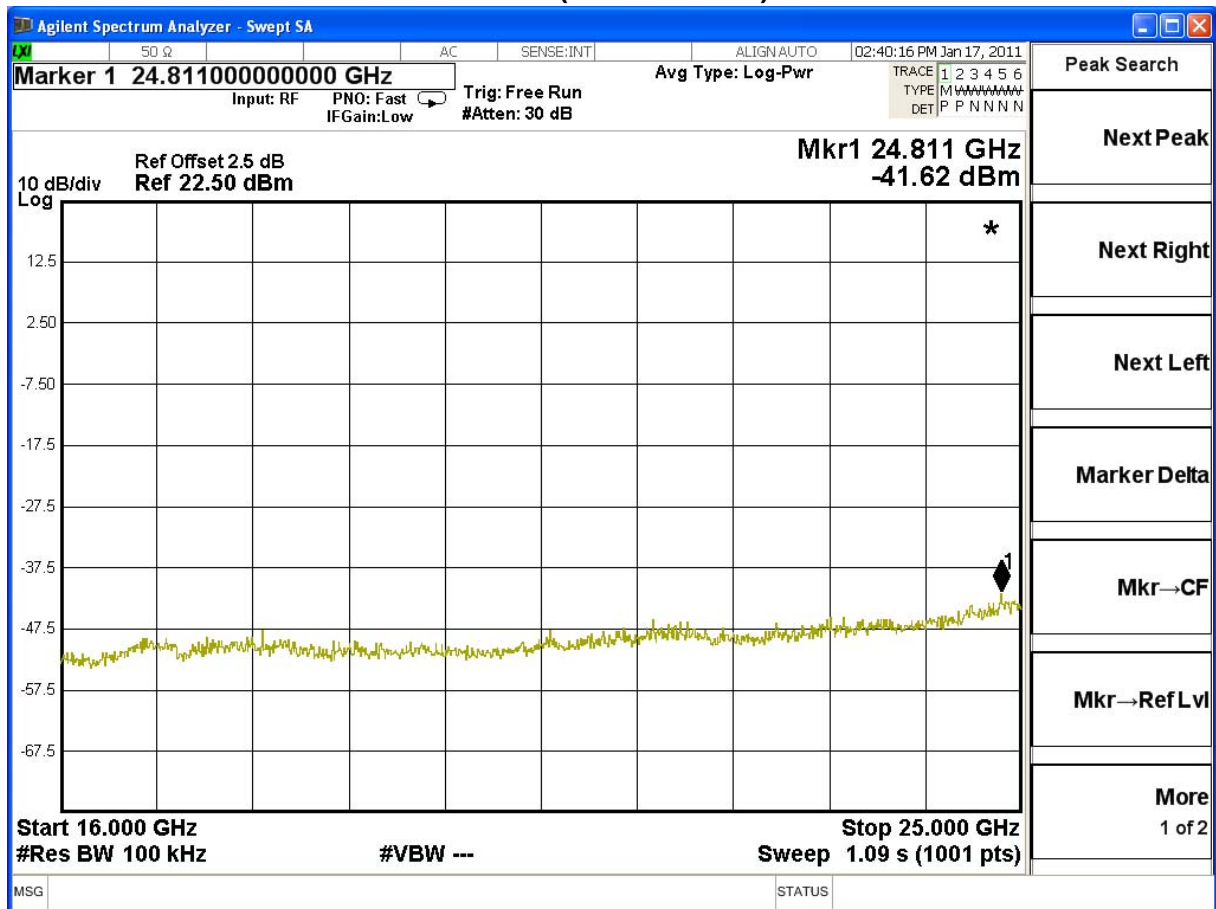

2412MHz (30MHz-1GHz)-g

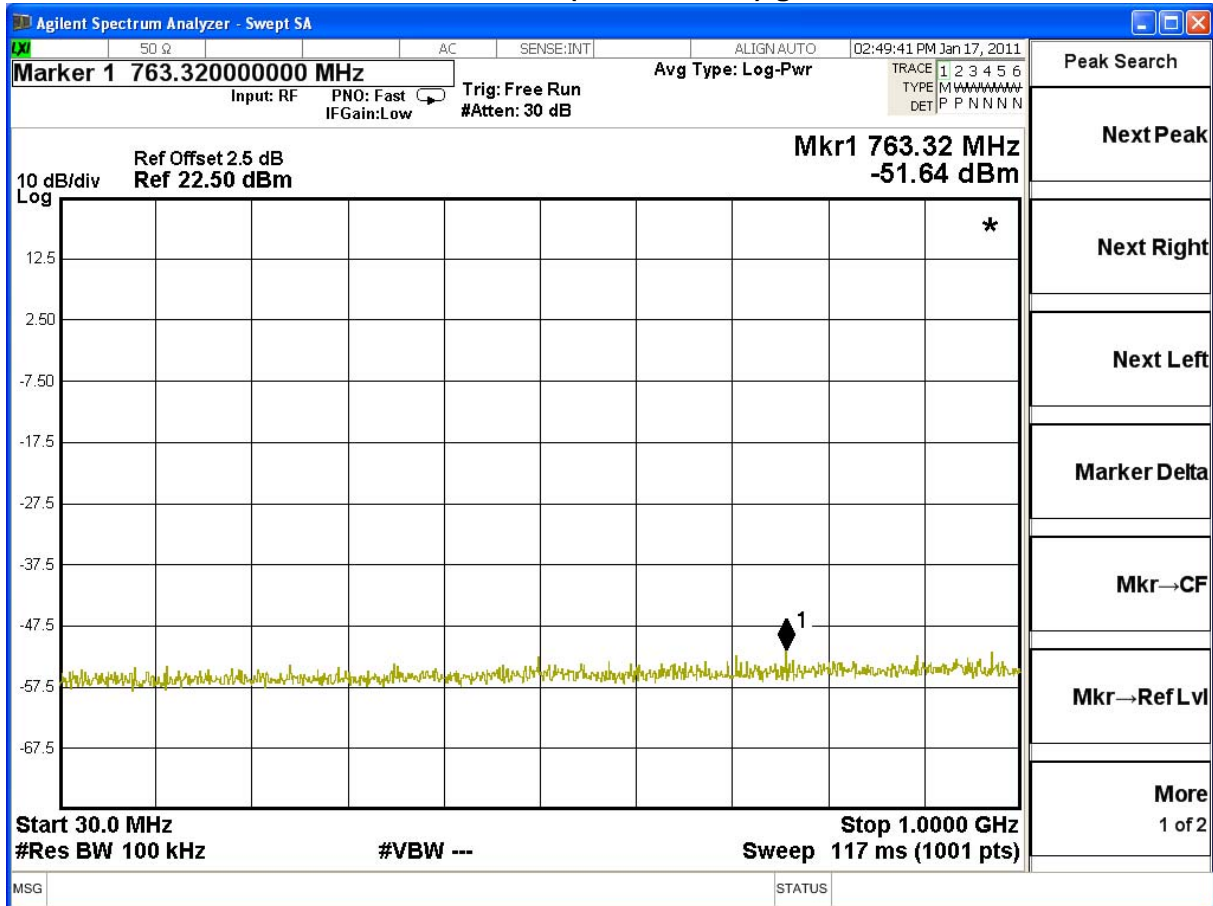







2412MHz (16GHz-25GHz)-g

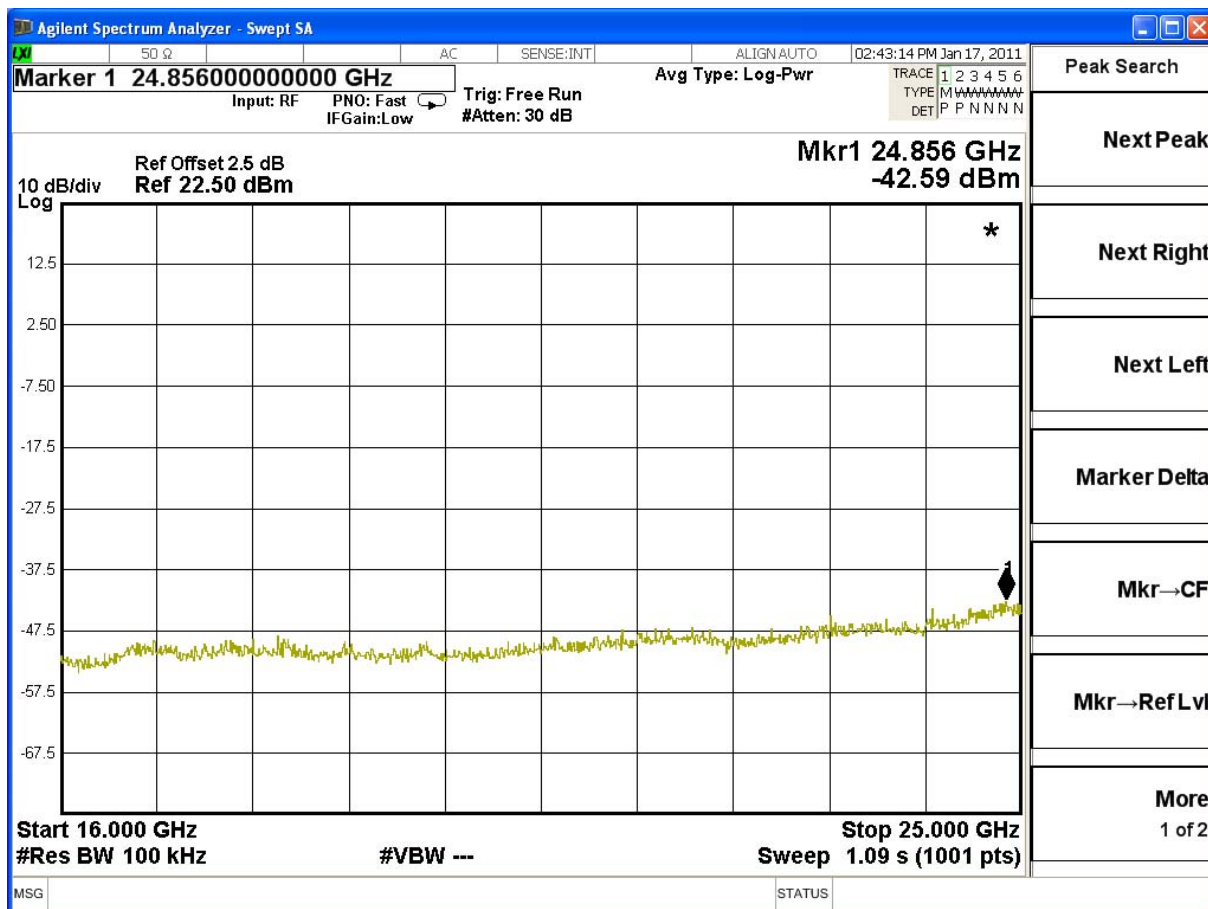



2437MHz (1GHz-8GHz)-g

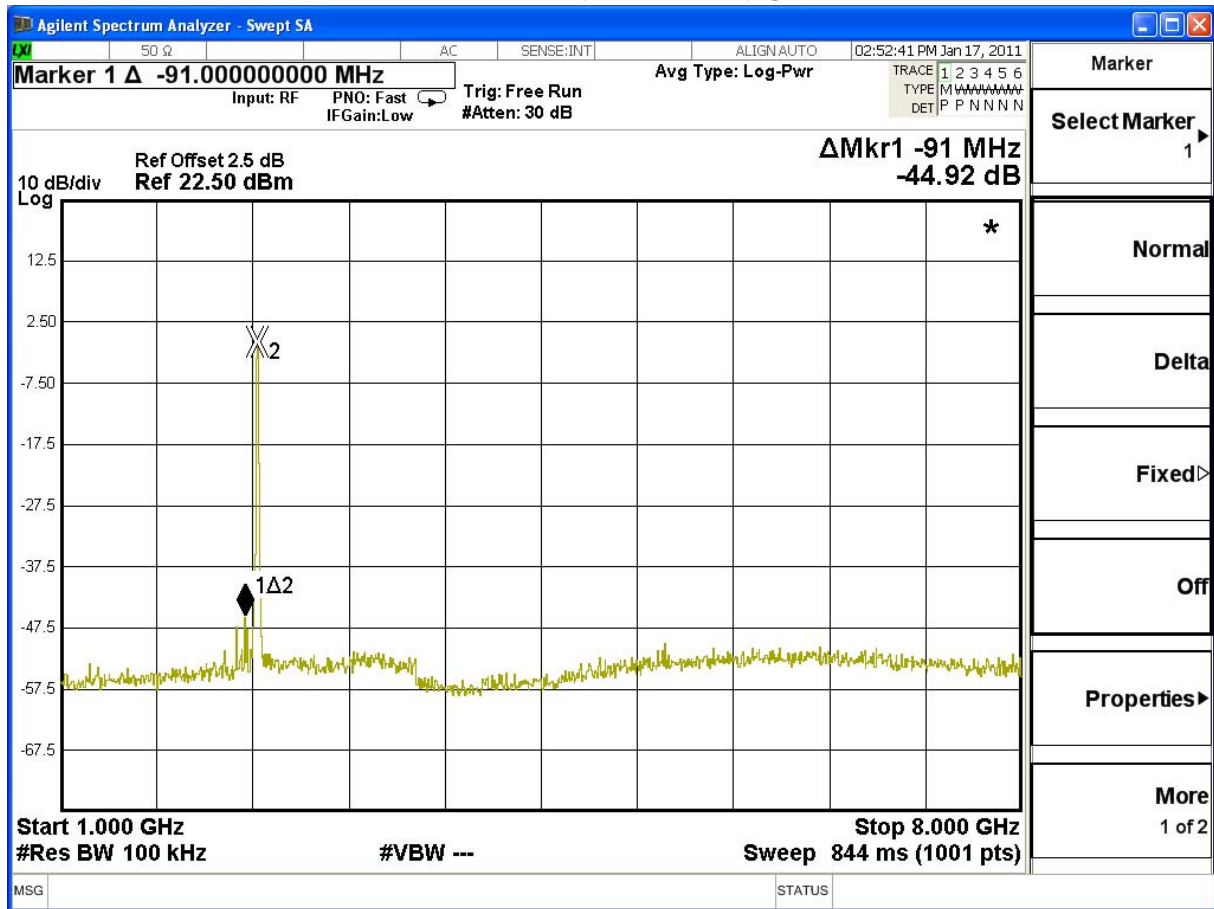

2437MHz (8GHz-16GHz)-g

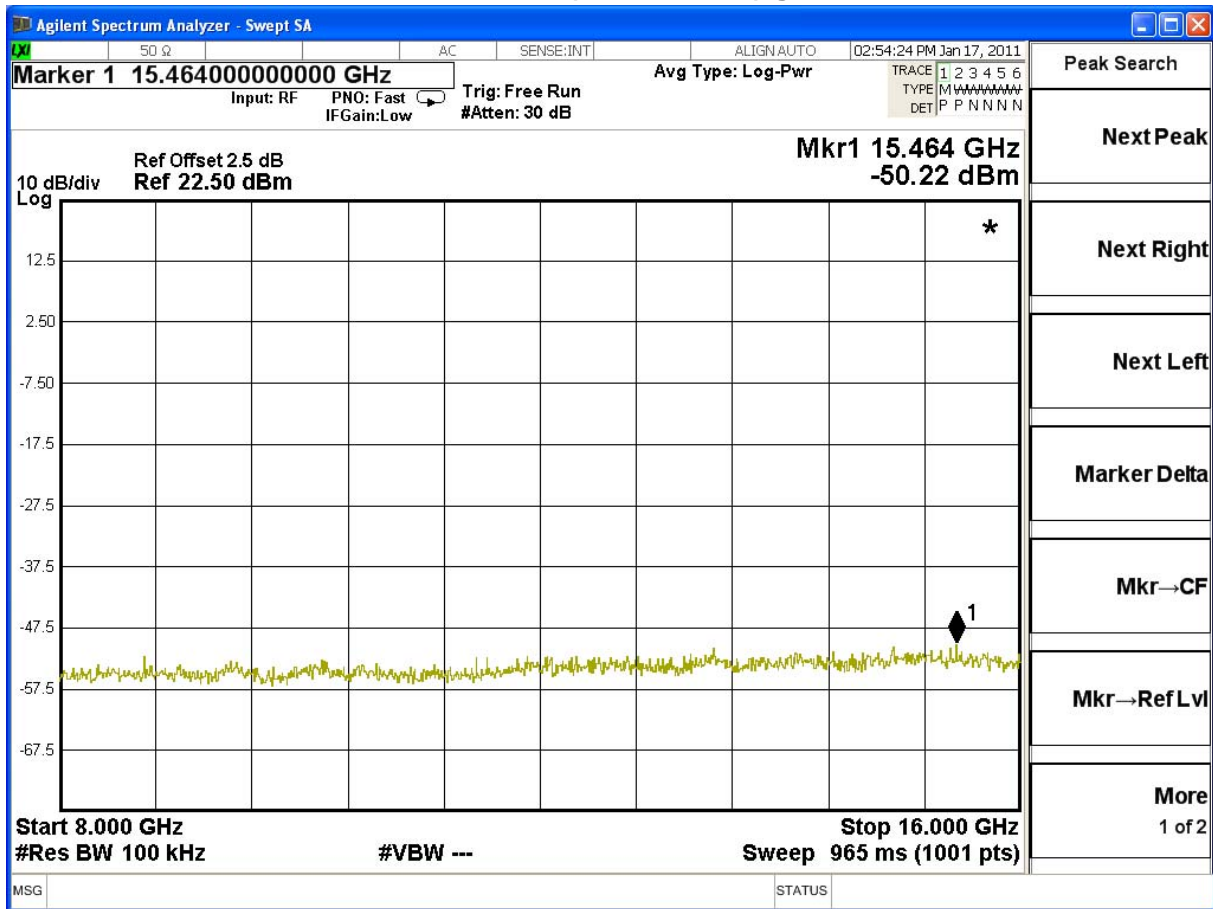

2437MHz (16GHz-25GHz)-g

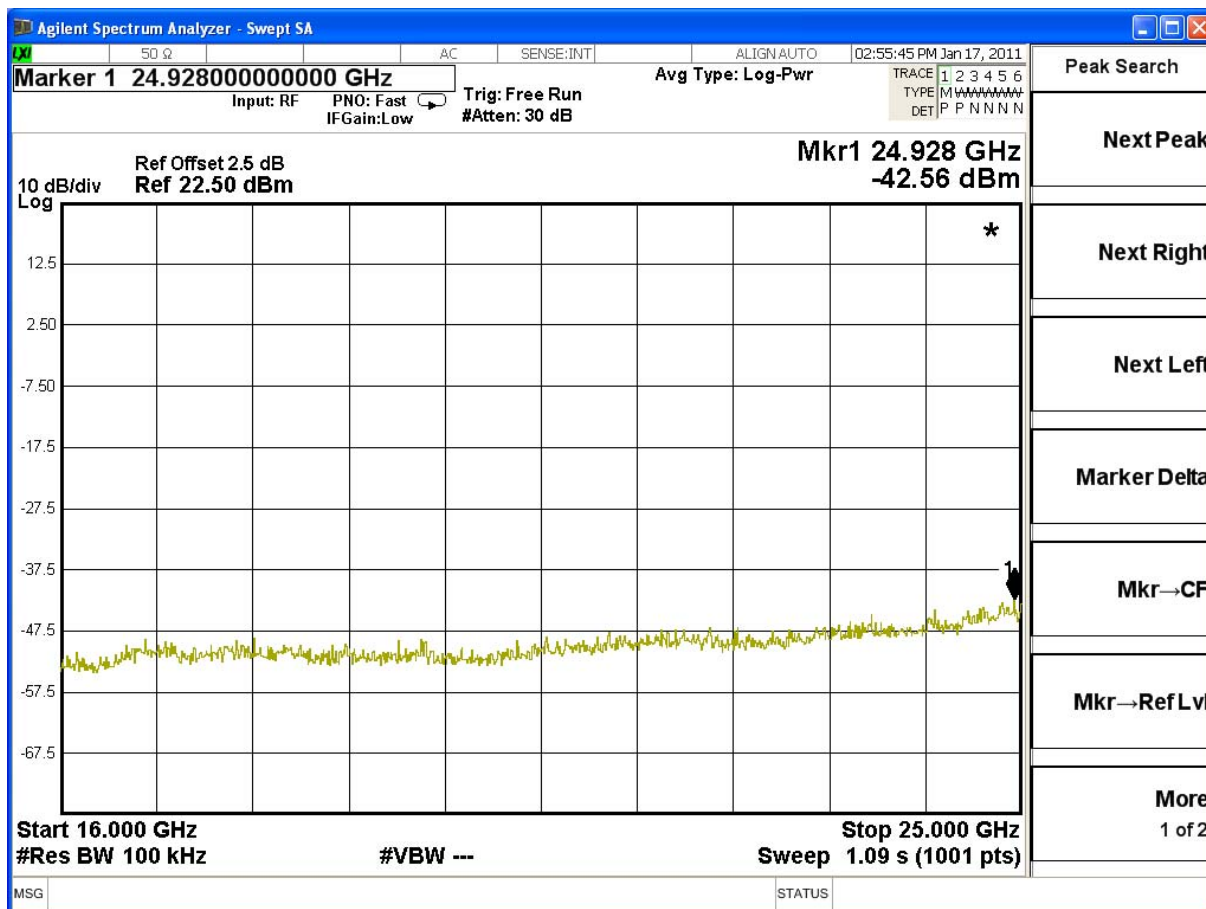

2462MHz (30MHz-1GHz)-g

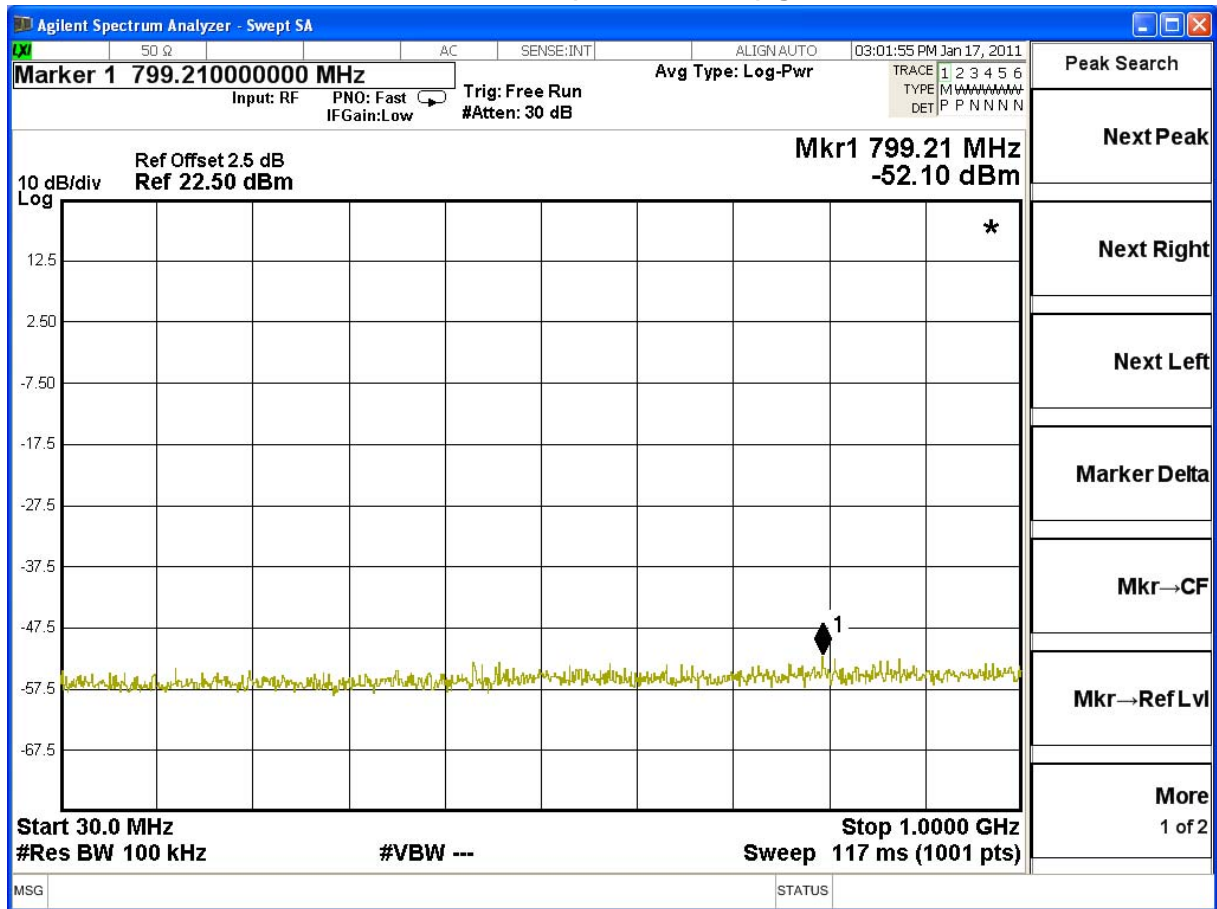



2462MHz (1GHz-8GHz)-g

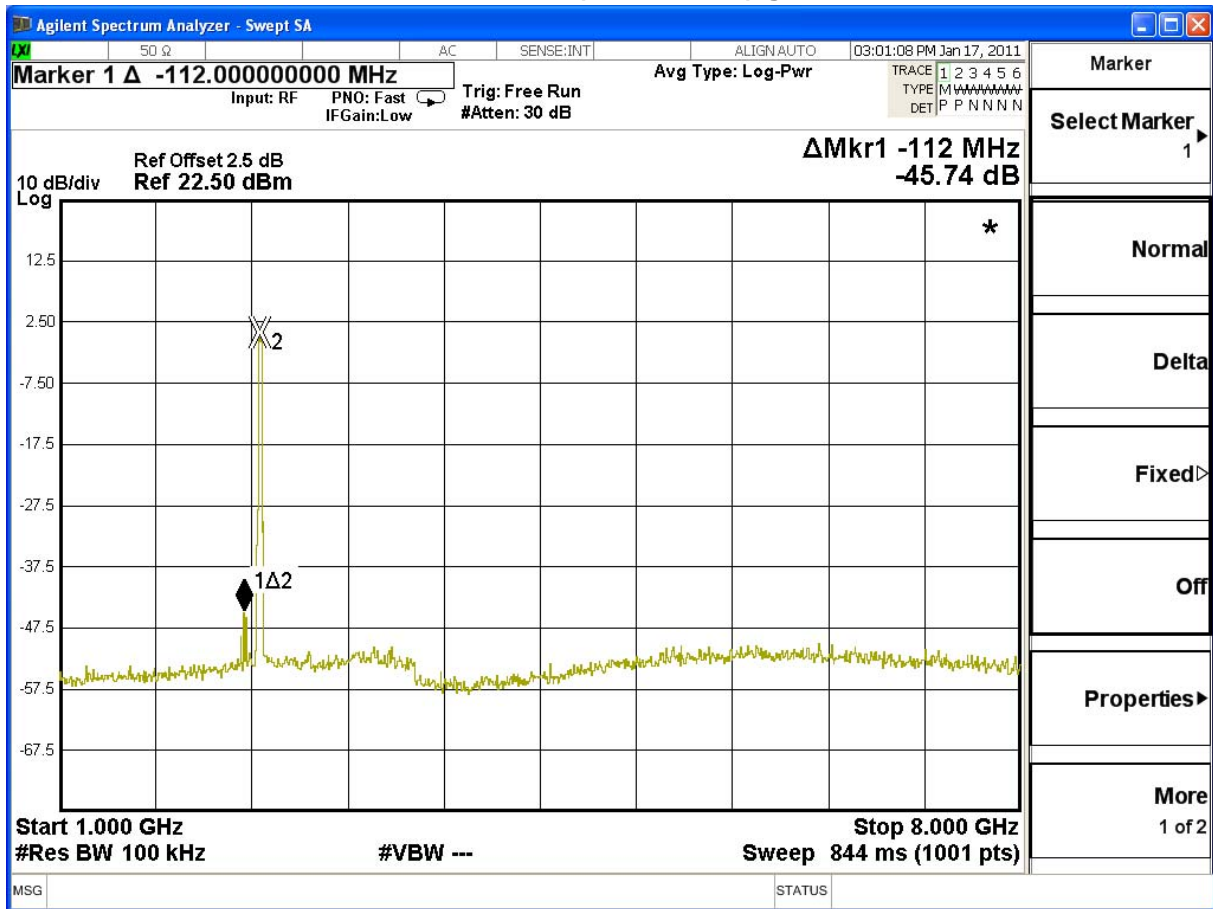

2462MHz (8GHz-16GHz)-g

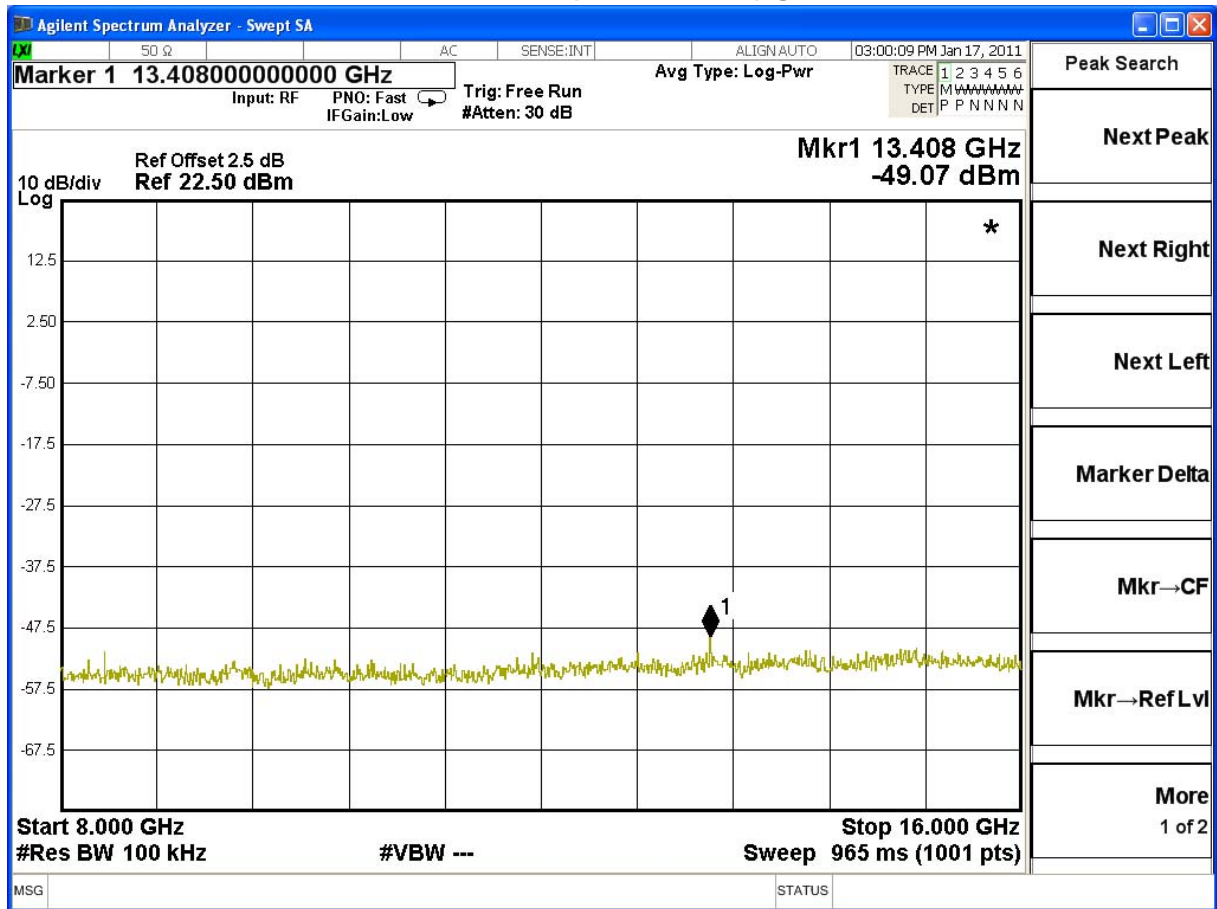

2462MHz (16GHz-25GHz)-g

