

# FCC Radio Test Report

## FCC ID: KA2CS8600LHA1

This report concerns (check one):  Original Grant  Class I Change  Class II Change

**Project No.** : 1806C009  
**Equipment** : Full HD Outdoor Wi-Fi Camera  
**Test Model** : DCS-8600LH  
**Series Model** : N/A  
**Applicant** : D-Link Corporation  
**Address** : 17595 Mt. Herrmann, Fountain Valley, California,  
United States 92708

**Date of Receipt** : Jun. 04, 2018  
**Date of Test** : Jun. 20, 2018 ~ Jul. 20, 2018  
**Issued Date** : Oct. 18, 2018  
**Tested by** : BTL Inc.

**Testing Engineer** : Vincent Tan  
( Vincent Tan)

**Technical Manager** : Shawn Xiao  
( Shawn Xiao)

**Authorized Signatory** : Steven Lu  
( Steven Lu)

# B T L I N C .

No.3, Jinshagang 1st Road, Shixia, Dalang Town, Dongguan,  
Guangdong, China.

TEL: +86-769-8318-3000 FAX: +86-769-8319-6000



Certificate #5123.02

### **Declaration**

**BTL** represents to the client that testing is done in accordance with standard procedures as applicable and that test instruments used has been calibrated with standards traceable to international standard(s) and/or national standard(s).

**BTL's** reports apply only to the specific samples tested under conditions. It is manufacture's responsibility to ensure that additional production units of this model are manufactured with the identical electrical and mechanical components. **BTL** shall have no liability for any declarations, inferences or generalizations drawn by the client or others from **BTL** issued reports.

The report must not be used by the client to claim product certification, approval, or endorsement by NVLAP, NIST, or any agency of the U.S. Government.

This report is the confidential property of the client. As a mutual protection to the clients, the public and ourselves, the test report shall not be reproduced, except in full, without our written approval.

**BTL's** laboratory quality assurance procedures are in compliance with the **ISO Guide 17025** requirements, and accredited by the conformity assessment authorities listed in this test report.

**BTL** is not responsible for the sampling stage, so the results only apply to the sample as received.

The information, data and test plan are provided by manufacturer, so it is manufacturer's responsibility to ensure that the apparatus meets the essential requirements in all the possible configurations as representative of its intended use.

### **Limitation**

For the use of the authority's logo is limited unless the Test Standard(s)/Scope(s)/Item(s) mentioned in this test report is (are) included in the conformity assessment authorities acceptance respective.

<b>Table of Contents</b>	<b>Page</b>
<b>1 . CERTIFICATION</b>	<b>7</b>
<b>2 . SUMMARY OF TEST RESULTS</b>	<b>8</b>
2.1 TEST FACILITY	9
2.2 MEASUREMENT UNCERTAINTY	9
<b>3 . GENERAL INFORMATION</b>	<b>10</b>
3.1 GENERAL DESCRIPTION OF EUT	10
3.2 DESCRIPTION OF TEST MODES	12
3.3 TABLE OF PARAMETERS OF TEXT SOFTWARE SETTING	12
3.4 BLOCK DIAGRAM SHOWING THE CONFIGURATION OF SYSTEM TESTED	13
3.5 DESCRIPTION OF SUPPORT UNITS	13
<b>4 . EMC EMISSION TEST</b>	<b>14</b>
4.1 CONDUCTED EMISSION MEASUREMENT	14
4.1.1 POWER LINE CONDUCTED EMISSION LIMITS	14
4.1.2 TEST PROCEDURE	14
4.1.3 DEVIATION FROM TEST STANDARD	14
4.1.4 TEST SETUP	15
4.1.5 EUT OPERATING CONDITIONS	15
4.1.6 EUT TEST CONDITIONS	15
4.1.7 TEST RESULTS	15
4.2 RADIATED EMISSION MEASUREMENT	16
4.2.1 RADIATED EMISSION LIMITS	16
4.2.2 TEST PROCEDURE	17
4.2.3 DEVIATION FROM TEST STANDARD	17
4.2.4 TEST SETUP	18
4.2.5 EUT OPERATING CONDITIONS	19
4.2.6 EUT TEST CONDITIONS	19
4.2.7 TEST RESULTS (9KHZ TO 30MHZ)	19
4.2.8 TEST RESULTS (30MHZ TO 1000MHZ)	19
4.2.9 TEST RESULTS (ABOVE 1000MHZ)	19
<b>5 . NUMBER OF HOPPING CHANNEL</b>	<b>20</b>
5.1 APPLIED PROCEDURES	20
5.1.1 TEST PROCEDURE	20
5.1.2 DEVIATION FROM STANDARD	20
5.1.3 TEST SETUP	20
5.1.4 EUT OPERATION CONDITIONS	20
5.1.5 EUT TEST CONDITIONS	20
5.1.6 TEST RESULTS	20
<b>6 . AVERAGE TIME OF OCCUPANCY</b>	<b>21</b>

<b>Table of Contents</b>	<b>Page</b>
<b>6.1 APPLIED PROCEDURES / LIMIT</b>	<b>21</b>
6.1.1 TEST PROCEDURE	21
6.1.2 DEVIATION FROM STANDARD	21
6.1.3 TEST SETUP	21
6.1.4 EUT OPERATION CONDITIONS	22
6.1.5 EUT TEST CONDITIONS	22
6.1.6 TEST RESULTS	22
<b>7 . HOPPING CHANNEL SEPARATION MEASUREMENT</b>	<b>23</b>
7.1 APPLIED PROCEDURES / LIMIT	23
7.1.1 TEST PROCEDURE	23
7.1.2 DEVIATION FROM STANDARD	23
7.1.3 TEST SETUP	23
7.1.4 EUT TEST CONDITIONS	23
7.1.5 TEST RESULTS	23
<b>8 . BANDWIDTH TEST</b>	<b>24</b>
8.1 APPLIED PROCEDURES	24
8.1.1 TEST PROCEDURE	24
8.1.2 DEVIATION FROM STANDARD	24
8.1.3 TEST SETUP	24
8.1.4 EUT OPERATION CONDITIONS	24
8.1.5 EUT TEST CONDITIONS	24
8.1.6 TEST RESULTS	24
<b>9 . PEAK OUTPUT POWER TEST</b>	<b>25</b>
9.1 APPLIED PROCEDURES / LIMIT	25
9.1.1 TEST PROCEDURE	25
9.1.2 DEVIATION FROM STANDARD	25
9.1.3 TEST SETUP	25
9.1.4 EUT OPERATION CONDITIONS	25
9.1.5 EUT TEST CONDITIONS	25
9.1.6 TEST RESULTS	25
<b>10 . ANTENNA CONDUCTED SPURIOUS EMISSION</b>	<b>26</b>
10.1 APPLIED PROCEDURES / LIMIT	26
10.1.1 TEST PROCEDURE	26
10.1.2 DEVIATION FROM STANDARD	26
10.1.3 TEST SETUP	26
10.1.4 EUT OPERATION CONDITIONS	26
10.1.5 EUT TEST CONDITIONS	26
10.1.6 TEST RESULTS	26
<b>11 . MEASUREMENT INSTRUMENTS LIST</b>	<b>27</b>
<b>12 . EUT TEST PHOTO</b>	<b>29</b>

**Table of Contents**

**Page**

<b>APPENDIX A - CONDUCTED EMISSION</b>	<b>33</b>
<b>APPENDIX B - RADIATED EMISSION (9KHZ-30MHZ)</b>	<b>36</b>
<b>APPENDIX C - RADIATED EMISSION (30MHZ TO 1000MHZ)</b>	<b>41</b>
<b>APPENDIX D - RADIATED EMISSION (ABOVE 1000MHZ)</b>	<b>48</b>
<b>APPENDIX E - NUMBER OF HOPPING CHANNEL</b>	<b>73</b>
<b>APPENDIX F - AVERAGE TIME OF OCCUPANCY</b>	<b>75</b>
<b>APPENDIX G - HOPPING CHANNEL SEPARATION MEASUREMENT</b>	<b>88</b>
<b>APPENDIX H - BANDWIDTH</b>	<b>93</b>
<b>APPENDIX I - PEAK OUTPUT POWER</b>	<b>98</b>
<b>APPENDIX J - ANTENNA CONDUCTED SPURIOUS EMISSION</b>	<b>103</b>

### REPORT ISSUED HISTORY

Issued No.	Description	Issued Date
BTL-FCCP-1-1806C009	Original Issue.	Oct. 18, 2018

## 1. CERTIFICATION

Equipment : Full HD Outdoor Wi-Fi Camera  
Brand Name : D-Link  
Test Model : DCS-8600LH  
Series Model : N/A  
Applicant : D-Link Corporation  
Manufacturer : D-Link Corporation  
Address : 17595 Mt. Herrmann, Fountain Valley, California, United States 92708  
Date of Test : Jun. 20, 2018 ~ Jul. 20, 2018  
Test Sample : Engineering Sample No.: D180605014  
Standard(s) : FCC Part15, Subpart C (15.247)  
ANSI C63.10-2013

The above equipment has been tested and found compliance with the requirement of the relative standards by BTL Inc.

The test data, data evaluation, and equipment configuration contained in our test report (Ref No. BTL-FCCP-1-1806C009) were obtained utilizing the test procedures, test instruments, test sites that has been accredited by the Authority of A2LA according to the ISO-17025 quality assessment standard and technical standard(s).

**Test results included in this report is only for the Buletooth EDR part.**

## 2. SUMMARY OF TEST RESULTS

Test procedures according to the technical standard(s):

Applied Standard(s): FCC Part15, Subpart C (15.247)			
Standard(s) Section	Test Item	Judgment	Remark
15.207	Conducted Emission	PASS	
15.247(d)	Antenna conducted Spurious Emission	PASS	
15.247 (a)(1)	Hopping Channel Separation	PASS	
15.247(a)(1)	Bandwidth	PASS	
15.247 (b)(1)	Peak Output Power	PASS	
15.247(d) 15.209	Radiated Spurious Emission	PASS	
15.247 (a)(1)(iii)	Number of Hopping Frequency	PASS	
15.247 (a)(1)(iii)	Dwell Time	PASS	
15.205	Restricted Bands	PASS	
15.203	Antenna Requirement	PASS	

Note:

(1) "N/A" denotes test is not applicable in this test report



## 2.1 TEST FACILITY

The test facilities used to collect the test data in this report is at the location of No.3, Jinshagang 1st Road, Shixia, Dalang Town, Dongguan, Guangdong, China.

BTL's test firm number for FCC: 854385

BTL's designation number for FCC: CN5020

## 2.2 MEASUREMENT UNCERTAINTY

The measurement uncertainty figures shall be calculated according the methods described in the ETSI TR 100 028 and shall correspond to an expansion factor (coverage factor)  $k=1.96$  or  $k=2$ (which provide confidence levels of respectively 90% and 95.45% in the case where the distributions characterizing the actual measurement uncertainties are normal (Gaussian)). Measurement Uncertainty for a Level of Confidence of 95 %,  $U=2xUc(y)$ .

The BTL measurement uncertainty as below table:

### A. Conducted Measurement :

Test Site	Method	Measurement Frequency Range	U, (dB)
DG-C02	CISPR	150 KHz ~ 30MHz	2.32

### B. Radiated Measurement :

Test Site	Method	Measurement Frequency Range	Ant. H / V	U, (dB)
DG-CB03	CISPR	9KHz~30MHz	V	3.79
		9KHz~30MHz	H	3.57
		30MHz ~ 200MHz	V	3.82
		30MHz ~ 200MHz	H	3.78
		200MHz ~ 1,000MHz	V	4.10
		200MHz ~ 1,000MHz	H	4.06
		1GHz~18GHz	V	3.12
		1GHz~18GHz	H	3.68
		18GHz~40GHz	V	4.15
		18GHz~40GHz	H	4.14

### C. Other Measurement:

Test Item	Uncertainty
Conducted Spurious Emission	2.67dB
Hopping Channel Separation	53.46MHz
Peak Output Power	0.95dB
Number of Hopping Frequency	53.46MHz
Temperature	0.08°C
Humidity	1.5%

Note: Unless specifically mentioned, the uncertainty of measurement has not been taken into account to declare the compliance or non-compliance to the specification.

### 3. GENERAL INFORMATION

#### 3.1 GENERAL DESCRIPTION OF EUT

Equipment	Full HD Outdoor Wi-Fi Camera	
Brand Name	D-Link	
Test Model	DCS-8600LH	
Series Model	N/A	
Model Difference	N/A	
Output Power (Max.)	Operation Frequency	2402~2480 MHz
	Modulation Technology	GFSK(1Mbps) $\pi/4$ -DQPSK(2Mbps)
	Bit Rate of Transmitter	8-DPSK(3Mbps)
	Output Power Max.	4.83 dBm(1Mbps) 6.49 dBm(3Mbps)
Power Source	DC Voltage supplied from AC/DC adapter. Brand/Model : D-Link/F10-050200SPAU	
Power Rating	I/P: 100-240V ~ 50/60Hz 0.3A O/P: 5V --- 2A	

Note:

1. For a more detailed features description, please refer to the manufacturer's specifications or the user's manual.

2. Channel List:

Channel	Frequency (MHz)	Channel	Frequency (MHz)	Channel	Frequency (MHz)
00	2402	27	2429	54	2456
01	2403	28	2430	55	2457
02	2404	29	2431	56	2458
03	2405	30	2432	57	2459
04	2406	31	2433	58	2460
05	2407	32	2434	59	2461
06	2408	33	2435	60	2462
07	2409	34	2436	61	2463
08	2410	35	2437	62	2464
09	2411	36	2438	63	2465
10	2412	37	2439	64	2466
11	2413	38	2440	65	2467
12	2414	39	2441	66	2468
13	2415	40	2442	67	2469
14	2416	41	2443	68	2470
15	2417	42	2444	69	2471
16	2418	43	2445	70	2472
17	2419	44	2446	71	2473
18	2420	45	2447	72	2474
19	2421	46	2448	73	2475
20	2422	47	2449	74	2476
21	2423	48	2450	75	2477
22	2424	49	2451	76	2478
23	2425	50	2452	77	2479
24	2426	51	2453	78	2480
25	2427	52	2454		
26	2428	53	2455		

3 Table for Filed Antenna:

Ant.	Brand	Model Name	Antenna Type	Connector	Gain (dBi)
1	T&W	N/A	PCB	N/A	3

### 3.2 DESCRIPTION OF TEST MODES

To investigate the maximum EMI emission characteristics generated from EUT, the test system was pre-scanning tested based on the consideration of following EUT operation mode or test configuration mode which possibly have effect on EMI emission level. Each of these EUT operation mode(s) or test configuration mode(s) mentioned above was evaluated respectively.

Pretest Mode	Description
Mode 1	TX Mode <b>Note (1)</b>

The EUT system operated these modes were found to be the worst case during the pre-scanning test as following:

For Conducted Emission	
Final Test Mode	Description
Mode 1	TX Mode

For Radiated Emission	
Final Test Mode	Description
Mode 1	TX Mode <b>Note (1)</b>

**Note:**

- (1) The measurements are performed at the high, middle, low available channels.
- (2) The measurements for Hopping Channel Separation, Bandwidth and Peak Output Power were tested during 1Mbps, 2Mbps and 3Mbps, the worst case are 1Mbps and 3Mbps, only worst case was documented.

### 3.3 TABLE OF PARAMETERS OF TEST SOFTWARE SETTING

During testing, channel & power controlling software provided by the customer was used to control the operating channel as well as the output power level. The RF output power selection is for the setting of RF output power expected by the customer and is going to be fixed on the firmware of the final end product power parameters of FHSS

Test Software Version	N/A		
Frequency	2402 MHz	2441 MHz	2480 MHz
Parameters(1Mbps)	0x06	0x06	0x05
Parameters(3Mbps)	0x06	0x06	0x05

### 3.4 BLOCK DIAGRAM SHOWING THE CONFIGURATION OF SYSTEM TESTED

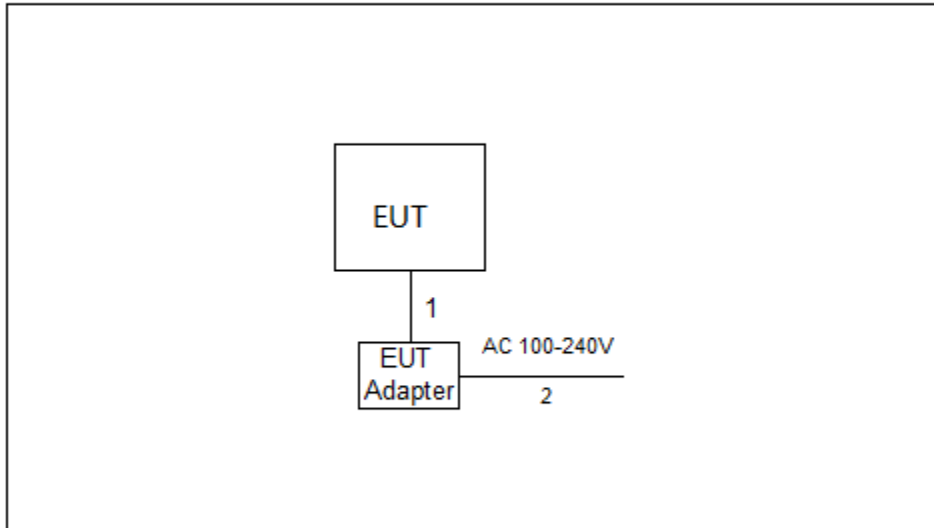

### 3.5 DESCRIPTION OF SUPPORT UNITS

The EUT has been tested as an independent unit together with other necessary accessories or support units. The following support units or accessories were used to form a representative test configuration during the tests.

Item	Equipment	Mfr/Brand	Model/Type No.	FCC ID	Series No.
-	-	-	-	-	-

Item	Shielded Type	Ferrite Core	Length	Note
1	NO	NO	3m	USB Cable
2	NO	NO	3.8m	AC Cable

## 4. EMC EMISSION TEST

### 4.1 CONDUCTED EMISSION MEASUREMENT

#### 4.1.1 POWER LINE CONDUCTED EMISSION LIMITS (Frequency Range 150KHz-30MHz)

Frequency of Emission (MHz)	Conducted Limit (dB $\mu$ V)	
	Quasi-peak	Average
0.15 -0.50	66 to 56*	56 to 46*
0.50 -5.0	56	46
5.0 -30.0	60	50

Note:

- (1) The limit of " \* " decreases with the logarithm of the frequency
- (2) The test result calculated as following:  
 Measurement Value = Reading Level + Correct Factor  
 Correct Factor = Insertion Loss + Cable Loss + Attenuator Factor(if use)  
 Margin Level = Measurement Value - Limit Value

The following table is the setting of the receiver

Receiver Parameters	Setting
Attenuation	10 dB
Start Frequency	0.15 MHz
Stop Frequency	30 MHz
IF Bandwidth	9 KHz

#### 4.1.2 TEST PROCEDURE

- a. The EUT was placed 0.8 meters from the horizontal ground plane with EUT being connected to the power mains through a line impedance stabilization network (LISN). All other support equipment powered from additional LISN(s). The LISN provide 50 Ohm/ 50uH of coupling impedance for the measuring instrument.
- b. Interconnecting cables that hang closer than 40 cm to the ground plane shall be folded back and forth in the center forming a bundle 30 to 40 cm long.
- c. I/O cables that are not connected to a peripheral shall be bundled in the center. The end of the cable may be terminated, if required, using the correct terminating impedance. The overall length shall not exceed 1 m.
- d. LISN at least 80 cm from nearest part of EUT chassis.
- e. For the actual test configuration, please refer to the related Item –EUT Test Photos.

#### 4.1.3 DEVIATION FROM TEST STANDARD

No deviation

#### 4.1.4 TEST SETUP

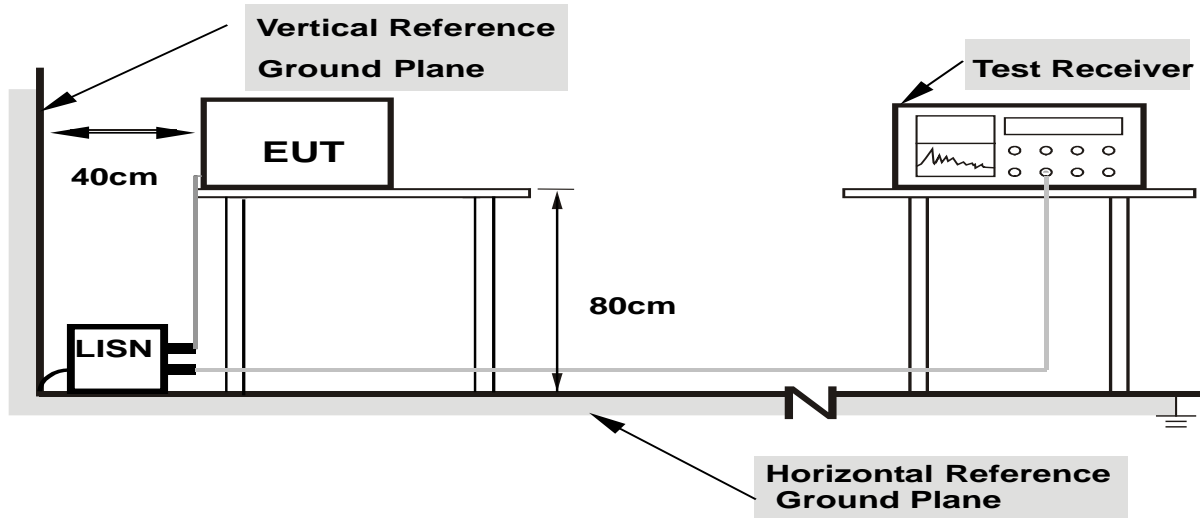

- Note:**
1. Support units were connected to second LISN.
  2. Both of LISNs (AMN) are 80 cm from EUT and at least 80 from other units and other metal planes

#### 4.1.5 EUT OPERATING CONDITIONS

The EUT was configured for testing in a typical function (as a customer would normally use it), EUT was programmed to be in continuously transmitting/receiving data or hopping on mode.

#### 4.1.6 EUT TEST CONDITIONS

Temperature: 25°C  
 Relative Humidity: 55%  
 Test Voltage: AC 120V/60Hz

#### 4.1.7 TEST RESULTS

Please refer to the Appendix A.

Remark:

- (1) All readings are QP Mode value unless otherwise stated AVG in column of『Note』. If the QP Mode Measured value compliance with the QP Limits and lower than AVG Limits, the EUT shall be deemed to meet both QP & AVG Limits and then only QP Mode was measured, but AVG Mode didn't perform in this case, a "\*" marked in AVG Mode column of Interference Voltage Measured.
- (2) Measuring frequency range from 150KHz to 30MHz.

## 4.2 RADIATED EMISSION MEASUREMENT

### 4.2.1 RADIATED EMISSION LIMITS (Frequency Range 9KHz -1000MHz)

In case the emission fall within the restricted band specified on 15.205(a), then the 15.209(a) limit in the table below has to be followed.

Frequency (MHz)	Field Strength (microvolts/meter)	Measurement Distance (meters)
0.009~0.490	2400/F(KHz)	300
0.490~1.705	24000/F(KHz)	30
1.705~30.0	30	30
30~88	100	3
88~216	150	3
216~960	200	3
960~1000	500	3

### LIMITS OF RADIATED EMISSION MEASUREMENT (Above 1000MHz)

Frequency (MHz)	(dBuV/m) (at 3 meters)	
	PEAK	AVERAGE
Above 1000	74	54

#### Notes:

- (1) The limit for radiated test was performed according to FCC PART 15C.
- (2) The tighter limit applies at the band edges.
- (3) Emission level (dBuV/m)=20log Emission level (uV/m).
- (4) The test result calculated as following:  
 Measurement Value = Reading Level + Correct Factor  
 Correct Factor = Antenna Factor + Cable Loss - Amplifier Gain(if use)  
 Margin Level = Measurement Value - Limit Value



Spectrum Parameter	Setting
Attenuation	Auto
Start Frequency	1000 MHz
Stop Frequency	10th carrier harmonic
RBW / VBW (emission in restricted band)	1 MHz / 1 MHz for Peak, 1 MHz / 10Hz for Average

Spectrum Receiver Parameter	Setting
Attenuation	Auto
Start ~ Stop Frequency	9KHz ~90KHz for PK/AVG detector
Start ~ Stop Frequency	90KHz ~110KHz for QP detector
Start ~ Stop Frequency	110KHz ~490KHz for PK/AVG detector
Start ~ Stop Frequency	490KHz ~30MHz for QP detector
Start ~ Stop Frequency	30MHz~1000MHz for QP detector

#### 4.2.2 TEST PROCEDURE

- a. The measuring distance of 3 m shall be used for measurements. The EUT was placed on the top of a rotating table 0.8 meter above the ground at a 3 meter semi-anechoic chamber. The table was rotated 360 degrees to determine the position of the highest radiation.(below 1GHz)
- b. The measuring distance of 3 m shall be used for measurements. The EUT was placed on the top of a rotating table 1.5 meter above the ground at a 3 meter semi-anechoic chamber. The table was rotated 360 degrees to determine the position of the highest radiation.(above 1GHz)
- c. The height of the equipment or of the substitution antenna shall be 0.8m or 1.5m; the height of the test antenna shall vary between 1 m to 4 m. Both horizontal and vertical polarizations of the antenna are set to make the measurement.
- d. For each suspected emission, the EUT was arranged to its worst case and then the antenna was tuned to heights find the maximum reading (used Bore sight function).
- e. The receiver system was set to peak and average detect function and specified bandwidth with maximum hold mode when the test frequency is above 1GHz.
- f. The initial step in collecting radiated emission data is a receiver peak detector mode pre-scanning the measurement frequency range. Significant peaks are then marked and then Quasi Peak detector mode re-measured.
- g. All readings are Peak unless otherwise stated QP in column of Note. Peak denotes that the Peak reading compliance with the QP Limits and then QP Mode measurement didn't perform. (below 1GHz)
- h. All readings are Peak Mode value unless otherwise stated AVG in column of Note. If the Peak Mode Measured value compliance with the Peak Limits and lower than AVG Limits, the EUT shall be deemed to meet both Peak & AVG Limits and then only Peak Mode was measured, but AVG Mode didn't perform. (above 1GHz)
- i. For the actual test configuration, please refer to the related Item –EUT Test Photos.

#### 4.2.3 DEVIATION FROM TEST STANDARD

No deviation

**4.2.4 TEST SETUP**

(A) Radiated Emission Test Set-Up Frequency Below 1 GHz

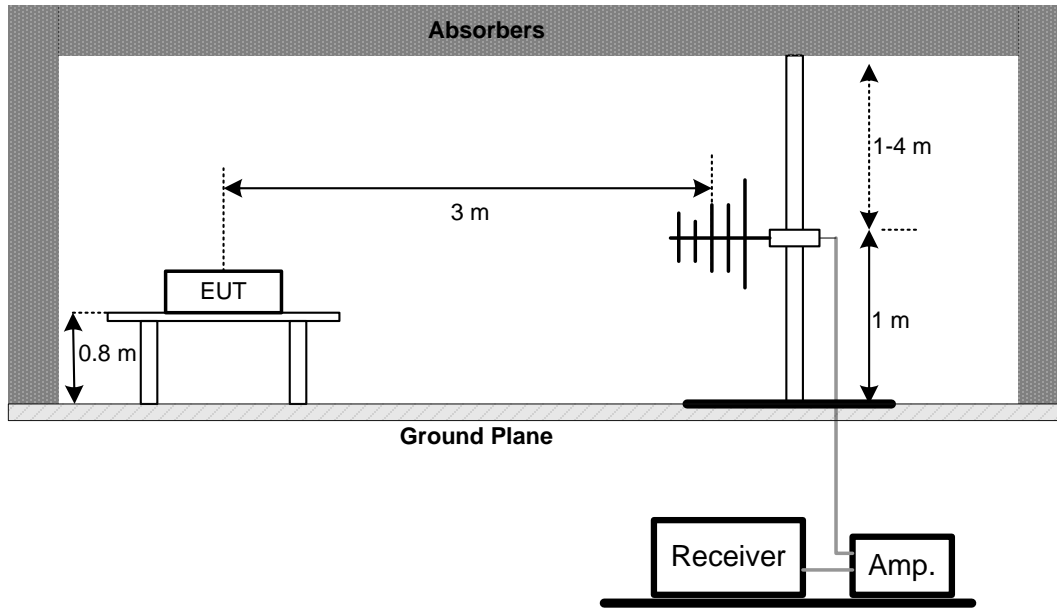

(B) Radiated Emission Test Set-Up Frequency Above 1 GHz

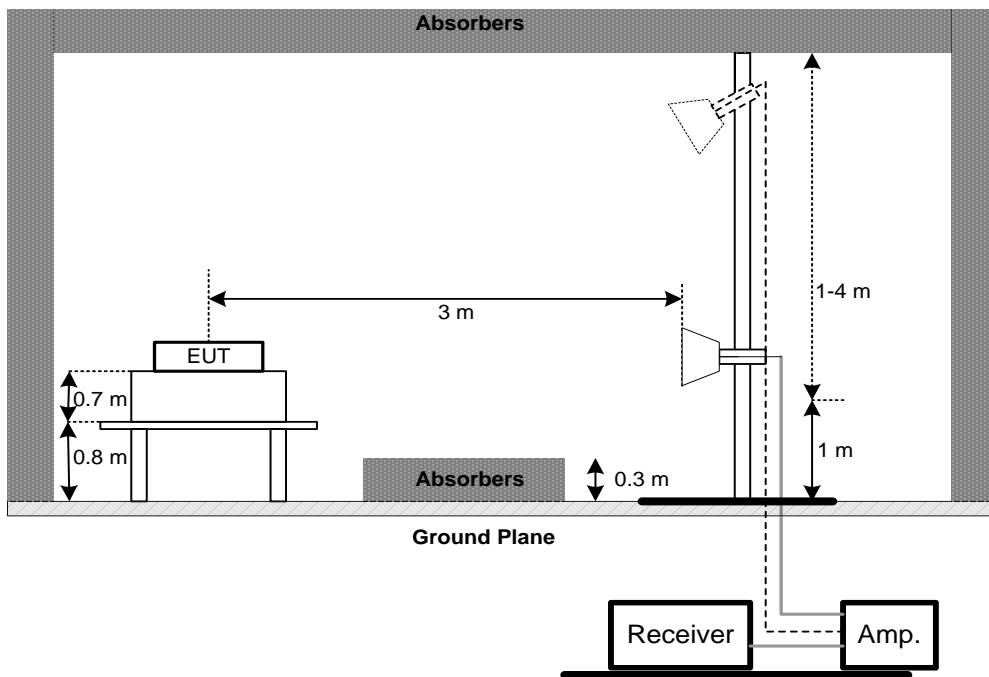

(C) For Radiated Emissions Below 30MHz

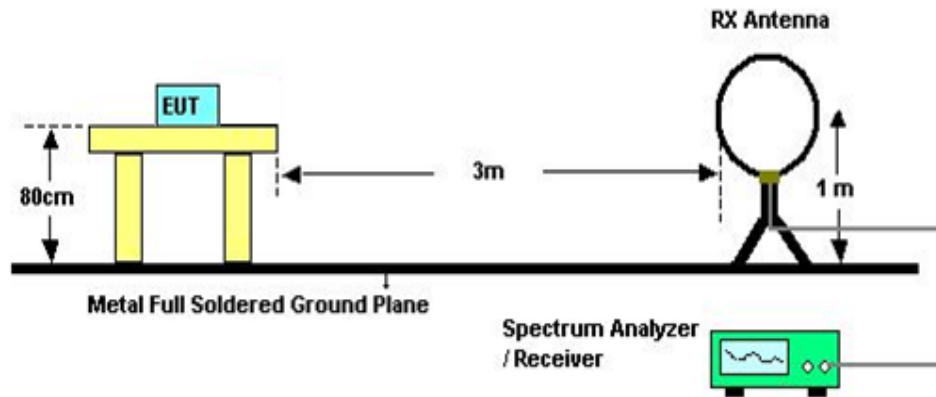

#### 4.2.5 EUT OPERATING CONDITIONS

The EUT was programmed to be in continuously transmitting mode.

#### 4.2.6 EUT TEST CONDITIONS

Temperature: 25°C

Relative Humidity: 55%

Test Voltage: AC 120V/60Hz

#### 4.2.7 TEST RESULTS (9KHZ TO 30MHZ)

Please refer to the Appendix B

Remark:

- (1) The amplitude of spurious emissions which are attenuated by more than 20 dB below the permissible value has no need to be reported.
- (2) Distance extrapolation factor =  $40 \log (\text{specific distance} / \text{test distance})$  (dB).
- (3) Limit line = specific limits (dBuV) + distance extrapolation factor.

#### 4.2.8 TEST RESULTS (30MHZ TO 1000MHZ)

Please refer to the Appendix C.

#### 4.2.9 TEST RESULTS (ABOVE 1000MHZ)

Please refer to the Appendix D.

Remark:

- (1) No limit: This is fundamental signal, the judgment is not applicable. For fundamental signal judgment was referred to Peak output test.

## 5. NUMBER OF HOPPING CHANNEL

### 5.1 APPLIED PROCEDURES

FCC Part15 (15.247) , Subpart C			
Section	Test Item	Frequency Range (MHz)	Result
15.247(a)(1)(iii)	Number of Hopping Channel	2400-2483.5	PASS

Spectrum Parameters	Setting
Attenuation	Auto
Span Frequency	> Operating Frequency Range
RBW	100 KHz
VBW	100 KHz
Detector	Peak
Trace	Max Hold
Sweep Time	Auto

#### 5.1.1 TEST PROCEDURE

- a. The EUT was directly connected to the spectrum analyzer and antenna output port as show in the block diagram below,
- b. Spectrum Setting: RBW=100KHz, VBW=100KHz, Sweep time = Auto.

#### 5.1.2 DEVIATION FROM STANDARD

No deviation.

#### 5.1.3 TEST SETUP



#### 5.1.4 EUT OPERATION CONDITIONS

The EUT tested system was configured as the statements of 4.1.5 unless otherwise a special operating condition is specified in the follows during the testing.

#### 5.1.5 EUT TEST CONDITIONS

Temperature: 25°C  
 Relative Humidity: 55%  
 Test Voltage: AC 120V/60Hz

#### 5.1.6 TEST RESULTS

Please refer to the Appendix E

## 6. AVERAGE TIME OF OCCUPANCY

### 6.1 APPLIED PROCEDURES / LIMIT

FCC Part15 (15.247) , Subpart C				
Section	Test Item	Limit	Frequency Range (MHz)	Result
15.247(a)(1)(iii)	Average Time of Occupancy	0.4sec	2400-2483.5	PASS

#### 6.1.1 TEST PROCEDURE

- a. The transmitter output (antenna port) was connected to the spectrum analyzer
- b. Set RBW of spectrum analyzer to 1MHz and VBW to 1MHz.
- c. Use a video trigger with the trigger level set to enable triggering only on full pulses.
- d. Sweep Time is more than once pulse time.
- e. Set the center frequency on any frequency would be measure and set the frequency span to zero span.
- f. Measure the maximum time duration of one single pulse.
- g. Set the EUT for DH5, DH3 and DH1 packet transmitting.
- h. Measure the maximum time duration of one single pulse.
  - i. DH5 Packet permit maximum  $1600 / 79 / 6 = 3.37$  hops per second in each channel (5 time slots TX, 1 time slot RX). So, the dwell time is the time duration of the pulse times  $3.37 \times 31.6 = 106.6$  within 31.6 seconds.
  - j. DH3 Packet permit maximum  $1600 / 79 / 4 = 5.06$  hops per second in each channel (3 time slots TX, 1 time slot RX). So, the dwell time is the time duration of the pulse times  $5.06 \times 31.6 = 160$  within 31.6 seconds.
  - k. DH1 Packet permit maximum  $1600 / 79 / 2 = 10.12$  hops per second in each channel (1 time slot TX, 1 time slot RX). So, the dwell time is the time duration of the pulse times  $10.12 \times 31.6 = 320$  within 31.6 seconds.

#### 6.1.2 DEVIATION FROM STANDARD

No deviation.

#### 6.1.3 TEST SETUP

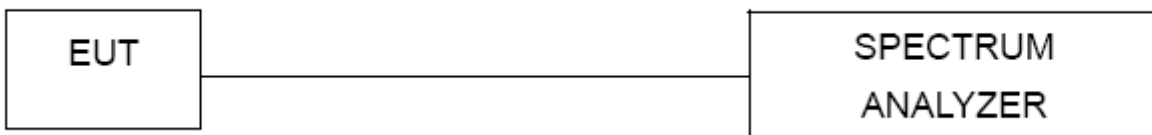

#### **6.1.4 EUT OPERATION CONDITIONS**

The EUT tested system was configured as the statements of 4.1.5 unless otherwise a special operating condition is specified in the follows during the testing.

#### **6.1.5 EUT TEST CONDITIONS**

Temperature: 25°C

Relative Humidity: 55%

Test Voltage: AC 120V/60Hz

#### **6.1.6 TEST RESULTS**

Please refer to the Appendix F

## 7. HOPPING CHANNEL SEPARATION MEASUREMENT

### 7.1 APPLIED PROCEDURES / LIMIT

Frequency hopping systems operating in the 2400-2483.5 MHz band may have hopping channel carrier frequencies that are separated by 25 KHz or two-thirds of the 20 dB bandwidth of the hopping channel, whichever is greater.

Spectrum Parameter	Setting
Attenuation	Auto
Span Frequency	> Measurement Bandwidth or Channel Separation
RBW	30 KHz
VBW	100 KHz
Detector	Peak
Trace	Max Hold
Sweep Time	Auto

#### 7.1.1 TEST PROCEDURE

- a. The EUT must have its hopping function enabled
- b. Span = wide enough to capture the peaks of two adjacent channels
  - Resolution (or IF) Bandwidth (RBW)  $\geq$  1% of the span
  - Video (or Average) Bandwidth (VBW)  $\geq$  RBW
  - Sweep = Auto
  - Detector function = Peak
  - Trace = Max Hold

#### 7.1.2 DEVIATION FROM STANDARD

No deviation.

#### 7.1.3 TEST SETUP

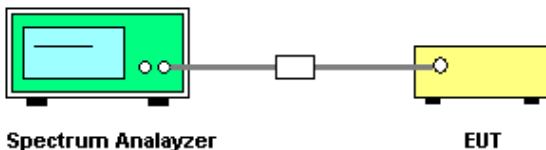

#### 7.1.4 EUT TEST CONDITIONS

Temperature: 25°C  
 Relative Humidity: 55%  
 Test Voltage: AC 120V/60Hz

#### 7.1.5 TEST RESULTS

Please refer to the Appendix G

## 8. BANDWIDTH TEST

### 8.1 APPLIED PROCEDURES

FCC Part15 (15.247) , Subpart C		
Section	Test Item	Frequency Range (MHz)
15.247(a)(2)	Bandwidth	2400-2483.5

Spectrum Parameter	Setting
Attenuation	Auto
Span Frequency	> Measurement Bandwidth or Channel Separation
RBW	30 KHz (20dB Bandwidth) / 30 KHz (Channel Separation)
VBW	100 KHz (20dB Bandwidth) / 100 KHz (Channel Separation)
Detector	Peak
Trace	Max Hold
Sweep Time	Auto

#### 8.1.1 TEST PROCEDURE

- a. The EUT was directly connected to the spectrum analyzer and antenna output port as show in the block diagram below,
- b. Spectrum Setting: RBW= 30KHz, VBW=100KHz, Sweep Time = Auto.

#### 8.1.2 DEVIATION FROM STANDARD

No deviation.

#### 8.1.3 TEST SETUP



#### 8.1.4 EUT OPERATION CONDITIONS

The EUT tested system was configured as the statements of 4.1.5 unless otherwise a special operating condition is specified in the follows during the testing.

#### 8.1.5 EUT TEST CONDITIONS

Temperature: 25°C  
 Relative Humidity: 55%  
 Test Voltage: AC 120V/60Hz

#### 8.1.6 TEST RESULTS

Please refer to the Appendix H



## 9. PEAK OUTPUT POWER TEST

### 9.1 APPLIED PROCEDURES / LIMIT

FCC Part15 (15.247) , Subpart C				
Section	Test Item	Limit	Frequency Range (MHz)	Result
15.247(b)(1)	Peak Output Power	0.125Watt or 21dBm	2400-2483.5	PASS

Note: Frequency hopping systems shall have hopping channel carrier frequencies separated by a minimum of 25 kHz or the 20 dB bandwidth of the hopping channel, whichever is greater. Alternatively, frequency hopping systems operating in the 2400-2483.5 MHz band may have hopping channel carrier frequencies that are separated by 25 kHz or two-thirds of the 20 dB bandwidth of the hopping channel, whichever is greater, provided the systems operate with an output power no greater than 125 mW.

#### 9.1.1 TEST PROCEDURE

- a. The EUT was directly connected to the spectrum analyzer and antenna output port as show in the block diagram below,
- b. Spectrum Setting: RBW= 1MHz/3MHz, VBW= 1MHz/3MHz, Sweep time = Auto.

#### 9.1.2 DEVIATION FROM STANDARD

No deviation.

#### 9.1.3 TEST SETUP

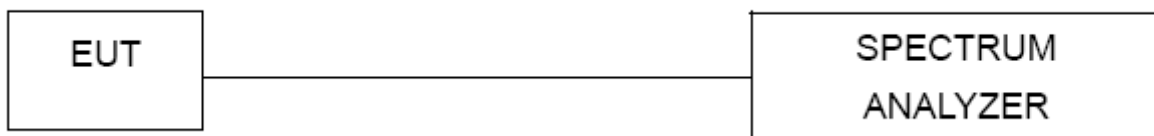

#### 9.1.4 EUT OPERATION CONDITIONS

The EUT tested system was configured as the statements of 4.1.5 unless otherwise a special operating condition is specified in the follows during the testing.

#### 9.1.5 EUT TEST CONDITIONS

Temperature: 25°C  
 Relative Humidity: 55%  
 Test Voltage: AC 120V/60Hz

#### 9.1.6 TEST RESULTS

Please refer to the Appendix I

## 10. ANTENNA CONDUCTED SPURIOUS EMISSION

### 10.1 APPLIED PROCEDURES / LIMIT

In any 100 kHz bandwidth outside the frequency band in which the spread spectrum or digitally modulated device is operating, the RF power that is produced shall be at least 20 dB below that in the 100 kHz bandwidth within the band that contains the highest level of the desired power, based on either an RF conducted or a radiated measurement, provided that the transmitter demonstrates compliance with the peak conducted power limits.

#### 10.1.1 TEST PROCEDURE

- a. The EUT was directly connected to the spectrum analyzer and antenna output port as show in the block diagram below,
- b. Spectrum Setting: RBW= 100KHz, VBW=100KHz, Sweep time = Auto.
- c. Offset=antenna gain+cable loss

#### 10.1.2 DEVIATION FROM STANDARD

No deviation.

#### 10.1.3 TEST SETUP

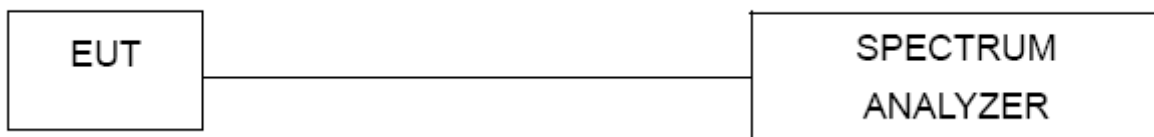

#### 10.1.4 EUT OPERATION CONDITIONS

The EUT tested system was configured as the statements of 4.1.5 unless otherwise a special operating condition is specified in the follows during the testing.

#### 10.1.5 EUT TEST CONDITIONS

Temperature: 25°C

Relative Humidity: 55%

Test Voltage: AC 120V/60Hz

#### 10.1.6 TEST RESULTS

Please refer to the Appendix J

## 11. MEASUREMENT INSTRUMENTS LIST

Conducted Emission Measurement					
Item	Kind of Equipment	Manufacturer	Type No.	Serial No.	Calibrated until
1	EMI Test Receiver	R&S	ESCI	100382	Mar. 11, 2019
2	LISN	EMCO	3816/2	52765	Mar. 11, 2019
3	50Ω Terminator	SHX	TF2-3G-A	8122901	Mar. 11, 2019
4	TWO-LINE V-NETWORK	R&S	ENV216	101447	Mar. 11, 2019
5	Measurement Software	Farad	EZ-EMC Ver.NB-03A1-01	N/A	N/A
6	Cable	N/A	RG223	12m	Oct. 19, 2018

Radiated Emission Measurement - Below 1GHz					
Item	Kind of Equipment	Manufacturer	Type No.	Serial No.	Calibrated until
1	Antenna	Schwarbeck	VULB9160	9160-3232	Mar. 11, 2019
2	Amplifier	HP	8447D	2944A09673	Oct. 19, 2018
3	Receiver	Agilent	N9038A	MY52130039	Aug. 20, 2018
4	Cable	emci	LMR-400(30MHz-1GHz)(8m+5m)	N/A	May. 25, 2019
5	Controller	CT	SC100	N/A	N/A
6	Controller	MF	MF-7802	MF780208416	N/A
7	Measurement Software	Farad	EZ-EMC Ver.NB-03A1-01	N/A	N/A
8	Antenna	EM	EM-6876-1	230	Feb. 07, 2019

Radiated Emission Measurement - Above 1GHz					
Item	Kind of Equipment	Manufacturer	Type No.	Serial No.	Calibrated until
1	Double Ridged Guide Antenna	ETS	3115	75789	Mar. 11, 2019
2	Broad-Band Horn Antenna	Schwarzbeck	BBHA 9170	9170319	Jun. 30, 2019
3	Amplifier	Agilent	8449B	3008A02274	Mar. 11, 2019
4	Microwave Preamplifier With Adaptor	EMC INSTRUMENT	EMC2654045	980039 & HA01	Mar. 11, 2019
5	Receiver	Agilent	N9038A	MY52130039	Aug. 20, 2018
6	Controller	CT	SC100	N/A	N/A
7	Controller	MF	MF-7802	MF780208416	N/A
8	Cable	emci	CA500-SMSM-12M (1-26.5GHz)	N/A	Sep. 29, 2018
9	Measurement Software	Farad	EZ-EMC Ver.NB-03A1-01	N/A	N/A

**Number of Hopping Channel**

Item	Kind of Equipment	Manufacturer	Type No.	Serial No.	Calibrated until
1	Spectrum Analyzer	R&S	FSP40	100185	Aug. 20, 2018

**Average Time of Occupancy**

Item	Kind of Equipment	Manufacturer	Type No.	Serial No.	Calibrated until
1	Spectrum Analyzer	R&S	FSP40	100185	Aug. 20, 2018

**Hopping Channel Separation Measurement**

Item	Kind of Equipment	Manufacturer	Type No.	Serial No.	Calibrated until
1	Spectrum Analyzer	R&S	FSP40	100185	Aug. 20, 2018

**Bandwidth**

Item	Kind of Equipment	Manufacturer	Type No.	Serial No.	Calibrated until
1	Spectrum Analyzer	R&S	FSP40	100185	Aug. 20, 2018

**Peak Output Power**

Item	Kind of Equipment	Manufacturer	Type No.	Serial No.	Calibrated until
1	Spectrum Analyzer	R&S	FSP40	100185	Aug. 20, 2018

**Antenna Conducted Spurious Emission**

Item	Kind of Equipment	Manufacturer	Type No.	Serial No.	Calibrated until
1	Spectrum Analyzer	R&S	FSP40	100185	Aug. 20, 2018

Remark: "N/A" denotes no model name, serial no. or calibration specified.  
 All calibration period of equipment list is one year.

## 12. EUT TEST PHOTO

### Conducted Measurement Photos



## Radiated Measurement Photos

9KHz to 30MHz

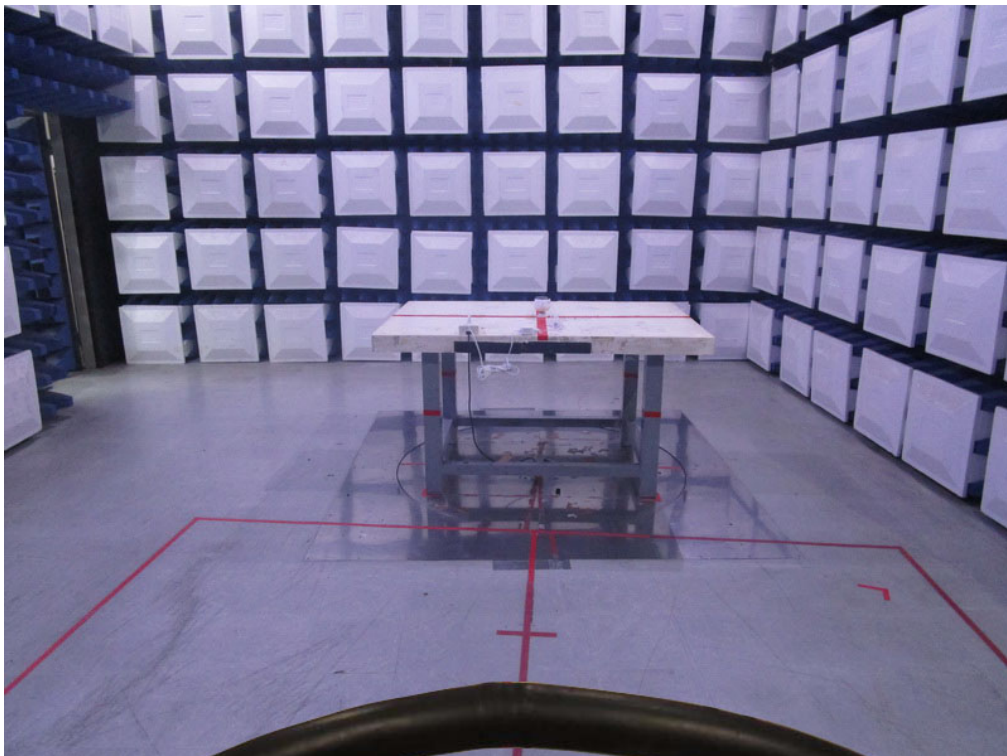

### Radiated Measurement Photos

30MHz to 1000MHz

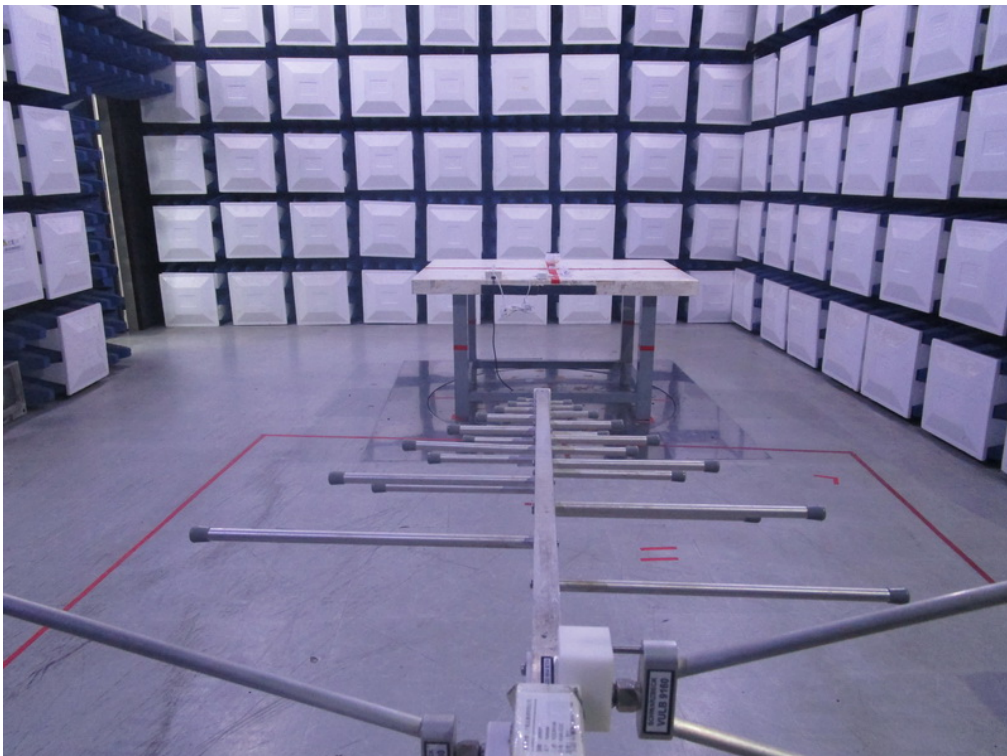
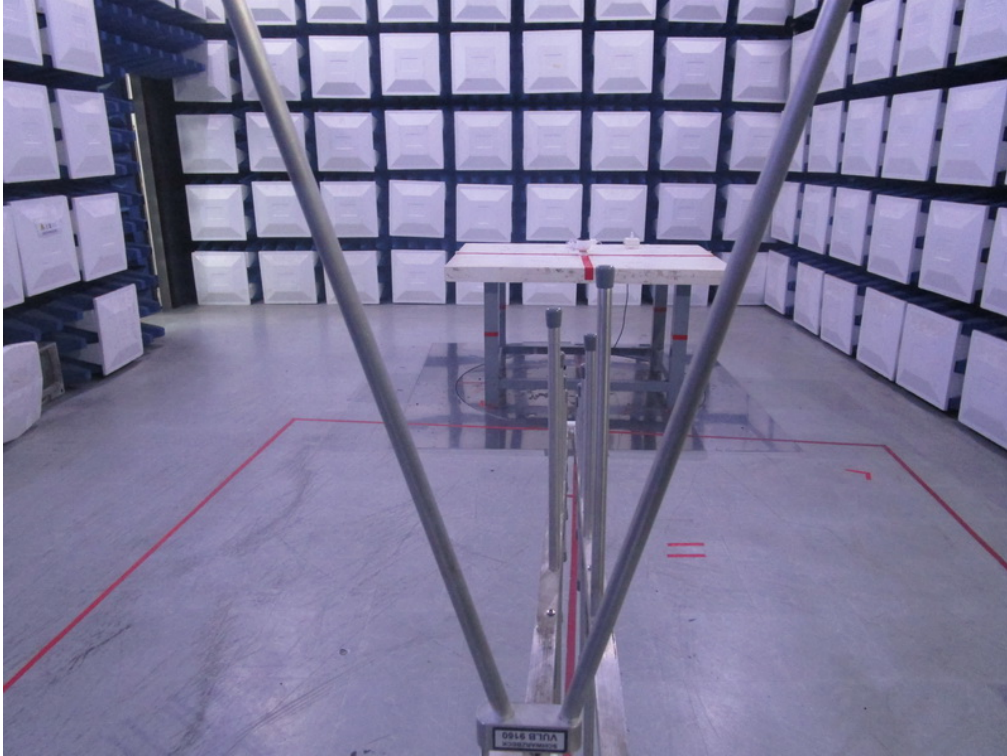

## Radiated Measurement Photos

### Above 1000MHz

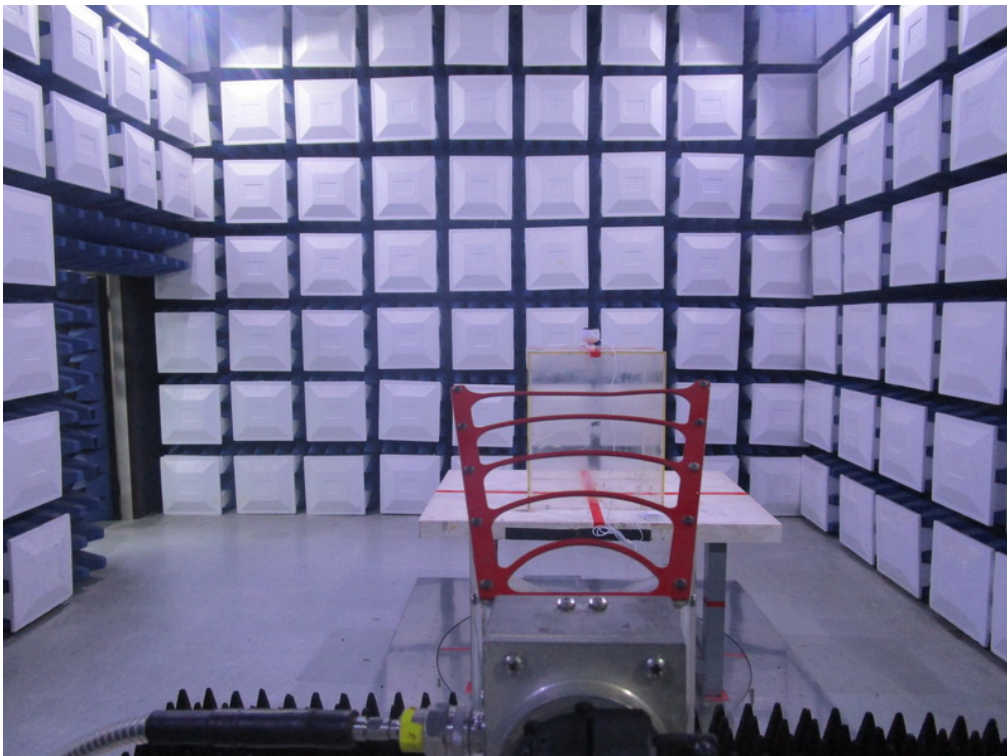



## APPENDIX A - CONDUCTED EMISSION

Test Mode: TX Mode

**Line**

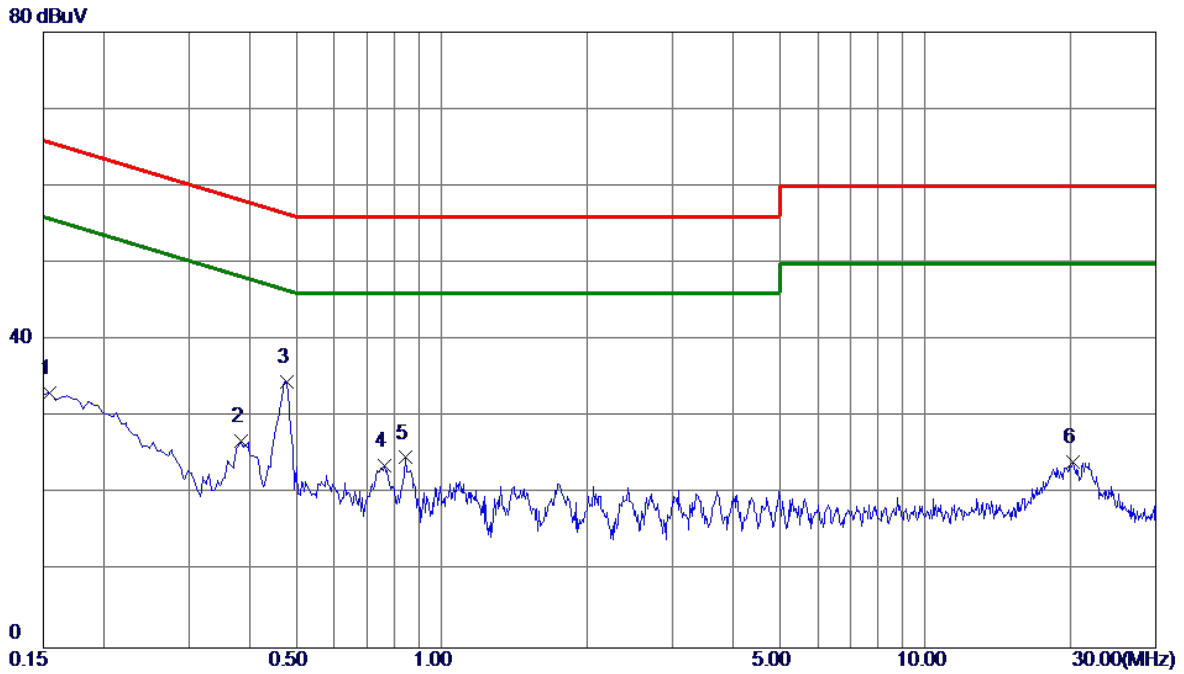

No.	Freq. MHz	Reading Level dBuV	Correct Factor dB	Measure ment dBuV	Limit dBuV	Margin dB	Detector	Comment
1	0.1545	23.37	9.82	33.19	65.75	-32.56	Peak	
2	0.3840	17.08	9.81	26.89	58.19	-31.30	Peak	
3 *	0.4785	24.83	9.79	34.62	56.37	-21.75	Peak	
4	0.7620	13.80	9.89	23.69	56.00	-32.31	Peak	
5	0.8430	14.81	9.91	24.72	56.00	-31.28	Peak	
6	20.1795	12.91	11.19	24.10	60.00	-35.90	Peak	

Test Mode: TX Mode

### Neutral

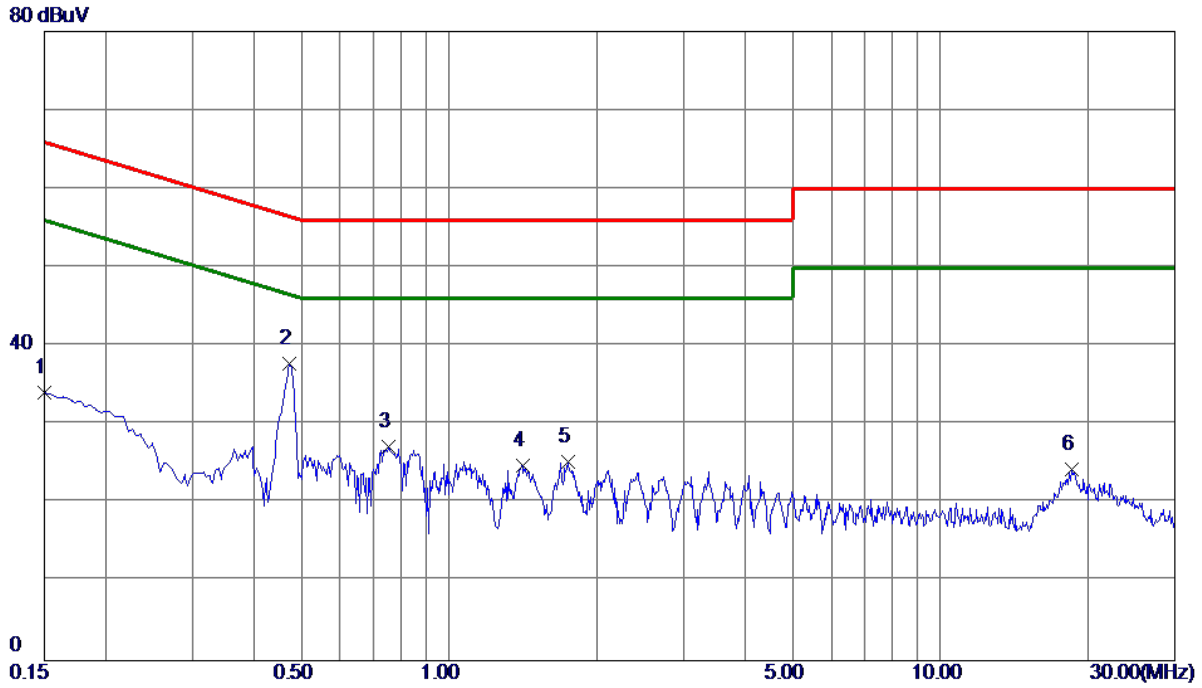

No.	Freq. MHz	Reading Level dBuV	Correct Factor dB	Measure ment dBuV	Limit dBuV	Margin dB	Detector	Comment
1	0.1500	24.14	9.91	34.05	66.00	-31.95	Peak	
2 *	0.4740	27.76	9.94	37.70	56.44	-18.74	Peak	
3	0.7530	17.20	10.07	27.27	56.00	-28.73	Peak	
4	1.4100	14.65	10.15	24.80	56.00	-31.20	Peak	
5	1.7430	15.09	10.17	25.26	56.00	-30.74	Peak	
6	18.5190	13.02	11.36	24.38	60.00	-35.62	Peak	

## APPENDIX B - RADIATED EMISSION (9KHZ-30MHZ)

Test Mode: TX Mode

Ant 0°

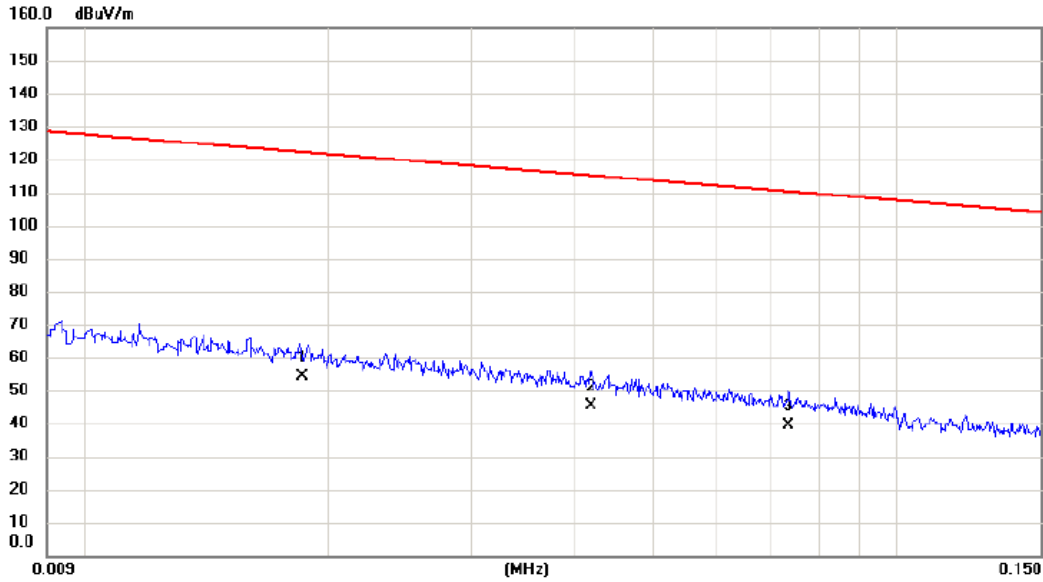

No.	Mk.	Freq. MHz	Reading Level dBuV	Correct Factor dB	Measure- ment dBuV/m	Limit dBuV/m	Margin dB	Detector	Comment
1	*	0.0185	33.80	20.23	54.03	122.26	-68.23	AVG	
2		0.0420	25.91	19.65	45.56	115.14	-69.58	AVG	
3		0.0734	20.30	19.06	39.36	110.29	-70.93	AVG	

Test Mode: TX Mode

Ant 0°

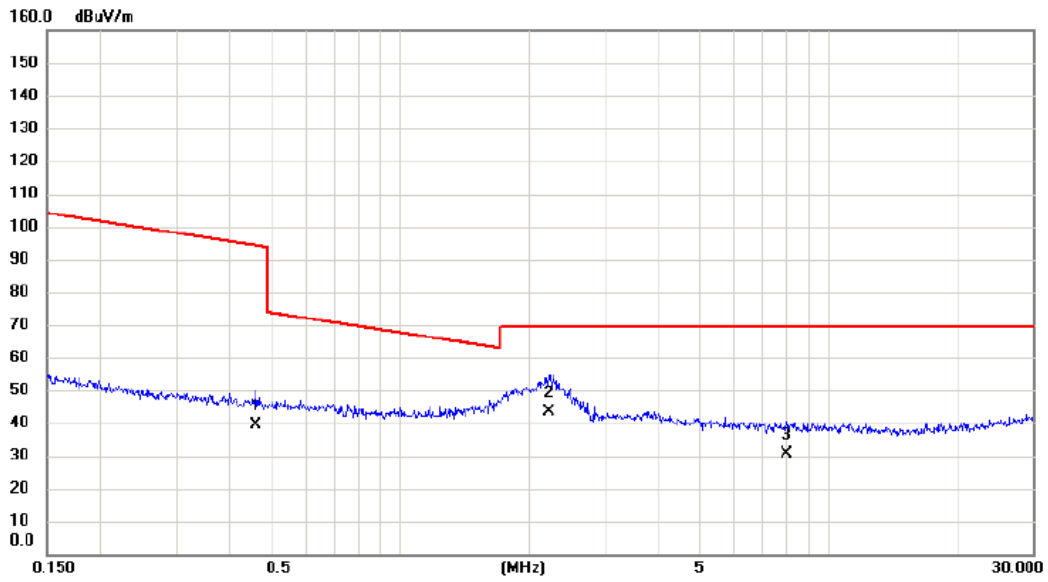

No.	Mk.	Freq. MHz	Reading Level dBuV	Correct Factor dB	Measure- ment dBuV/m	Limit dBuV/m	Margin dB	Detector	Comment
1		0.4612	22.60	16.99	39.59	94.33	-54.74	AVG	
2	*	2.2132	26.40	16.98	43.38	69.54	-26.16	QP	
3		7.9774	16.10	14.68	30.78	69.54	-38.76	QP	

Test Mode: TX Mode

Ant 90°

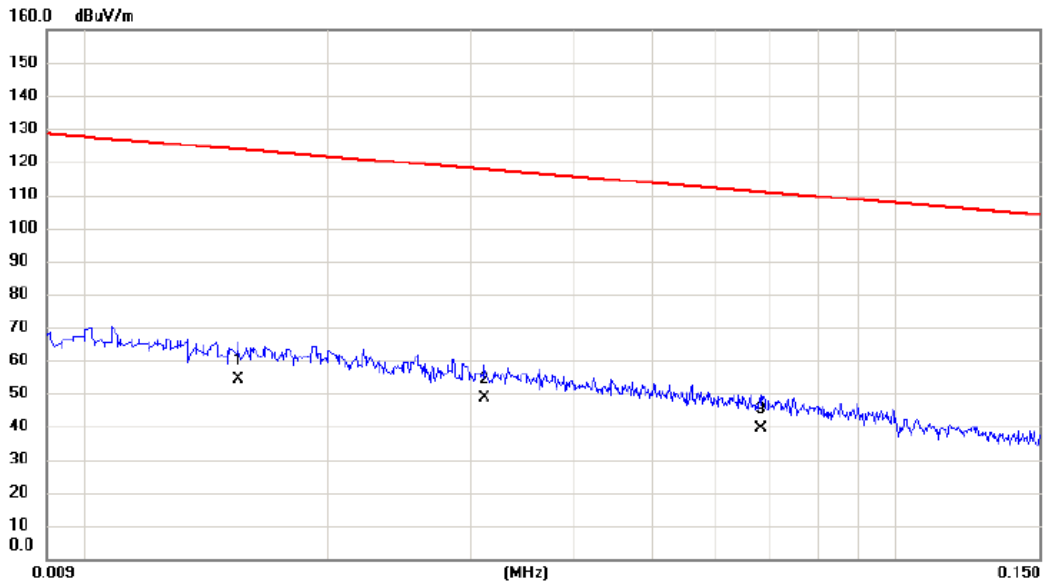

No.	Mk.	Freq. MHz	Reading Level dBuV	Correct Factor dB	Measure- ment dBuV/m	Limit dBuV/m	Margin dB	Detector	Comment
1		0.0155	33.70	20.65	54.35	123.80	-69.45	AVG	
2	*	0.0311	28.60	19.84	48.44	117.75	-69.31	AVG	
3		0.0680	20.30	19.17	39.47	110.95	-71.48	AVG	

Test Mode: TX Mode

Ant 90°

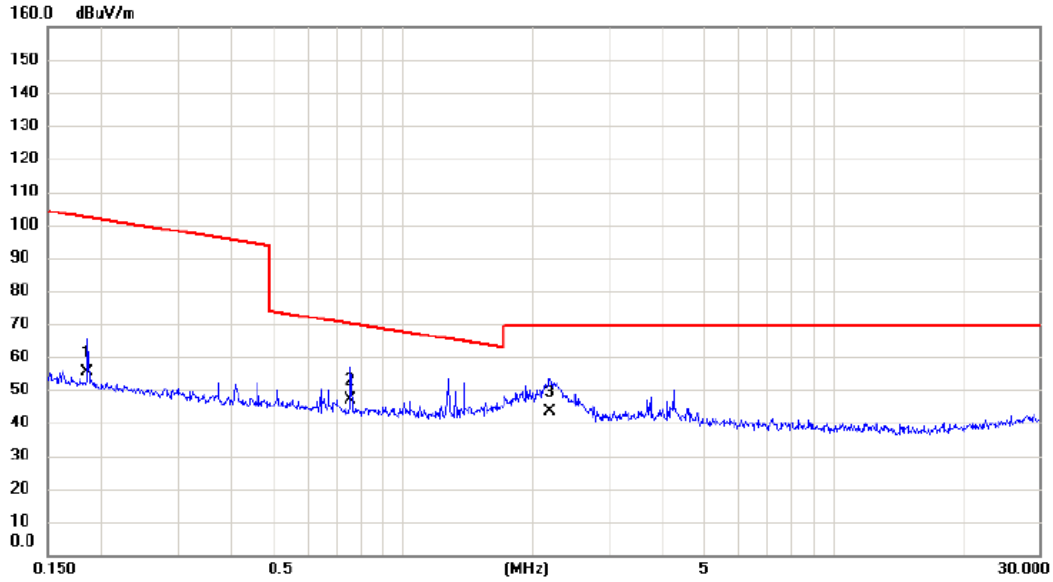

No.	Mk.	Freq. MHz	Reading Level dBuV	Correct Factor dB	Measure- ment dBuV/m	Limit dBuV/m	Margin dB	Detector	Comment
1		0.1853	38.30	17.18	55.48	102.25	-46.77	AVG	
2	*	0.7550	30.10	16.87	46.97	70.05	-23.08	QP	
3		2.1898	26.30	17.00	43.30	69.54	-26.24	QP	



## APPENDIX C - RADIATED EMISSION (30MHZ TO 1000MHZ)

Test Mode: TX 2402MHz \_CH00\_1Mbps

### Vertical

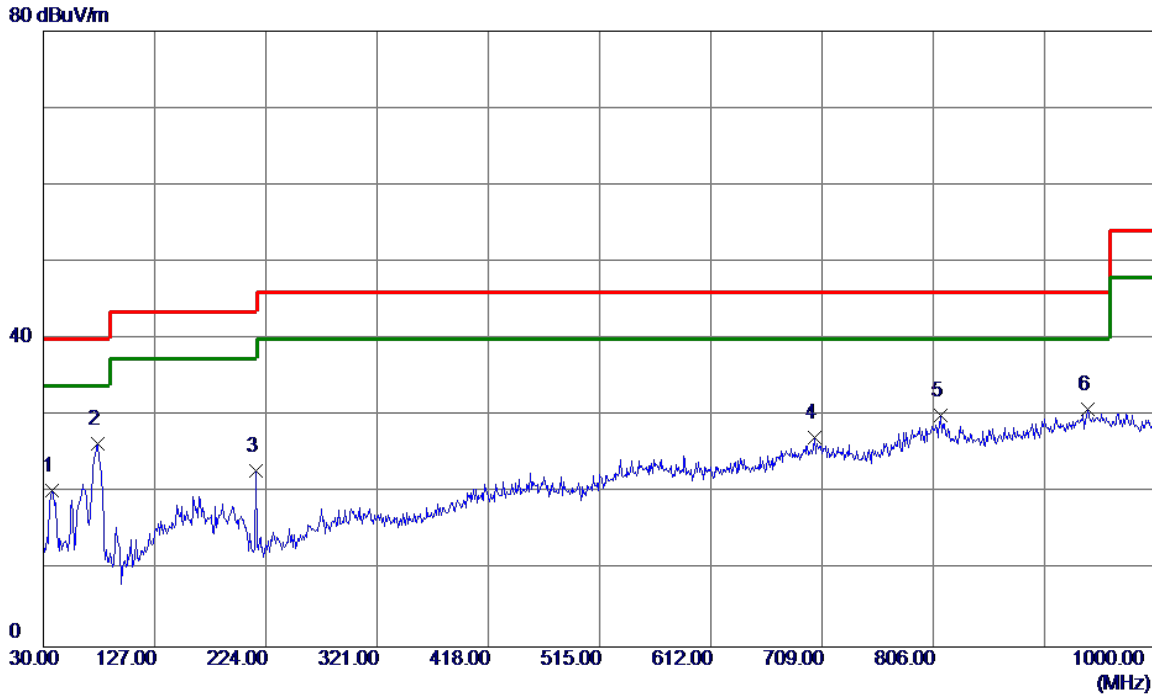

No.	Freq. MHz	Reading Level dBuV/m	Correct Factor dB	Measure ment dBuV/m	Limit dBuV/m	Margin dB	Detector	Comment
1	37.7599	34.96	-14.70	20.26	40.00	-19.74	Peak	
2 *	77.5300	44.88	-18.50	26.38	40.00	-13.62	Peak	
3	215.2700	37.83	-15.02	22.81	43.50	-20.69	Peak	
4	702.2100	29.93	-2.80	27.13	46.00	-18.87	Peak	
5	812.7900	31.29	-1.24	30.05	46.00	-15.95	Peak	
6	940.8300	29.91	1.04	30.95	46.00	-15.05	Peak	

Test Mode: TX 2402MHz \_CH00\_1Mbps

### Horizontal

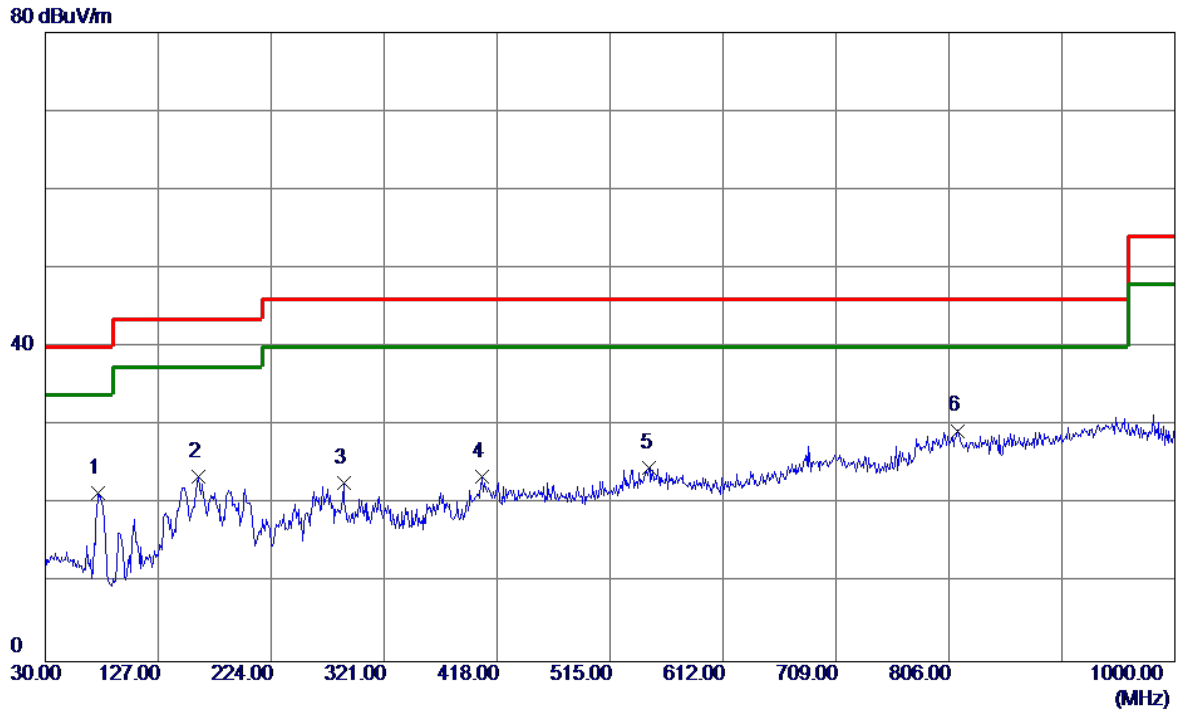

No.	Freq. MHz	Reading Level dBuV/m	Correct Factor dB	Measure ment dBuV/m	Limit dBuV/m	Margin dB	Detector	Comment
1	75.5899	39.86	-18.44	21.42	40.00	-18.58	Peak	
2	161.9200	34.23	-10.71	23.52	43.50	-19.98	Peak	
3	286.0799	33.75	-11.10	22.65	46.00	-23.35	Peak	
4	405.3900	32.69	-9.17	23.52	46.00	-22.48	Peak	
5	548.9500	30.18	-5.53	24.65	46.00	-21.35	Peak	
6 *	813.7600	30.61	-1.25	29.36	46.00	-16.64	Peak	

Test Mode: TX 2441MHz \_CH39\_1Mbps

### Vertical

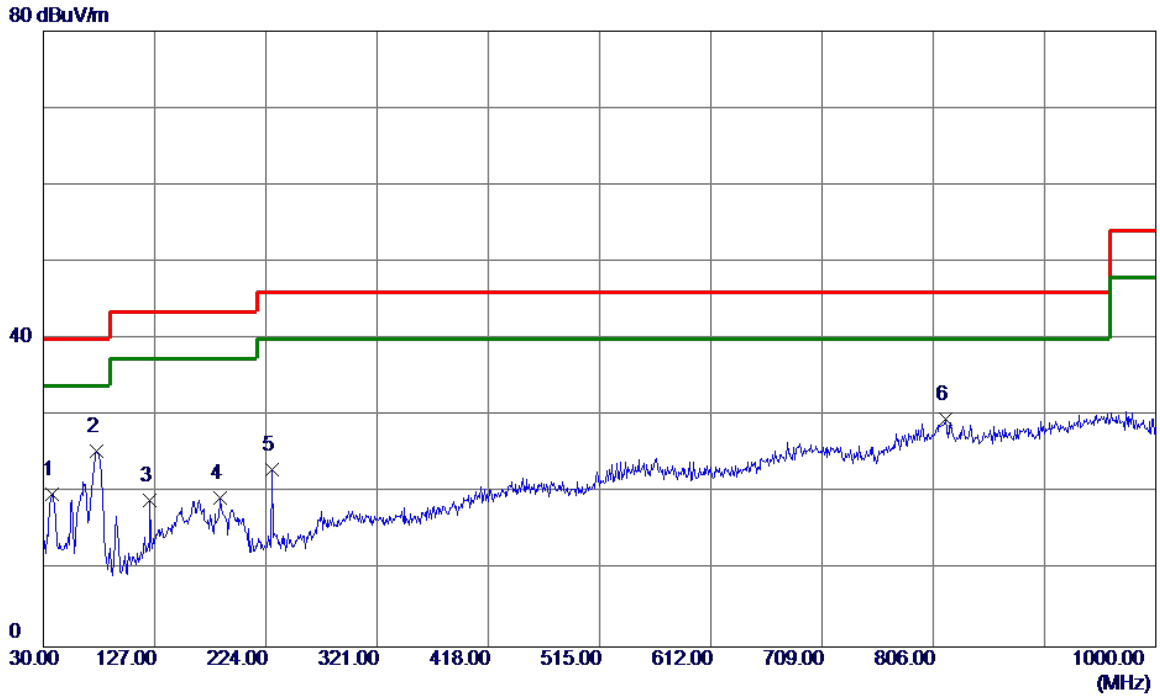

No.	Freq. MHz	Reading Level dBuV/m	Correct Factor dB	Measurement dBuV/m	Limit dBuV/m	Margin dB	Detector	Comment
1	37.7599	34.61	-14.70	19.91	40.00	-20.09	Peak	
2 *	76.5600	43.96	-18.47	25.49	40.00	-14.51	Peak	
3	123.1200	33.32	-14.28	19.04	43.50	-24.46	Peak	
4	184.2300	32.73	-13.44	19.29	43.50	-24.21	Peak	
5	229.8200	38.07	-14.96	23.11	46.00	-22.89	Peak	
6	816.6700	30.97	-1.30	29.67	46.00	-16.33	Peak	

Test Mode: TX 2441MHz \_CH39\_1Mbps

### Horizontal

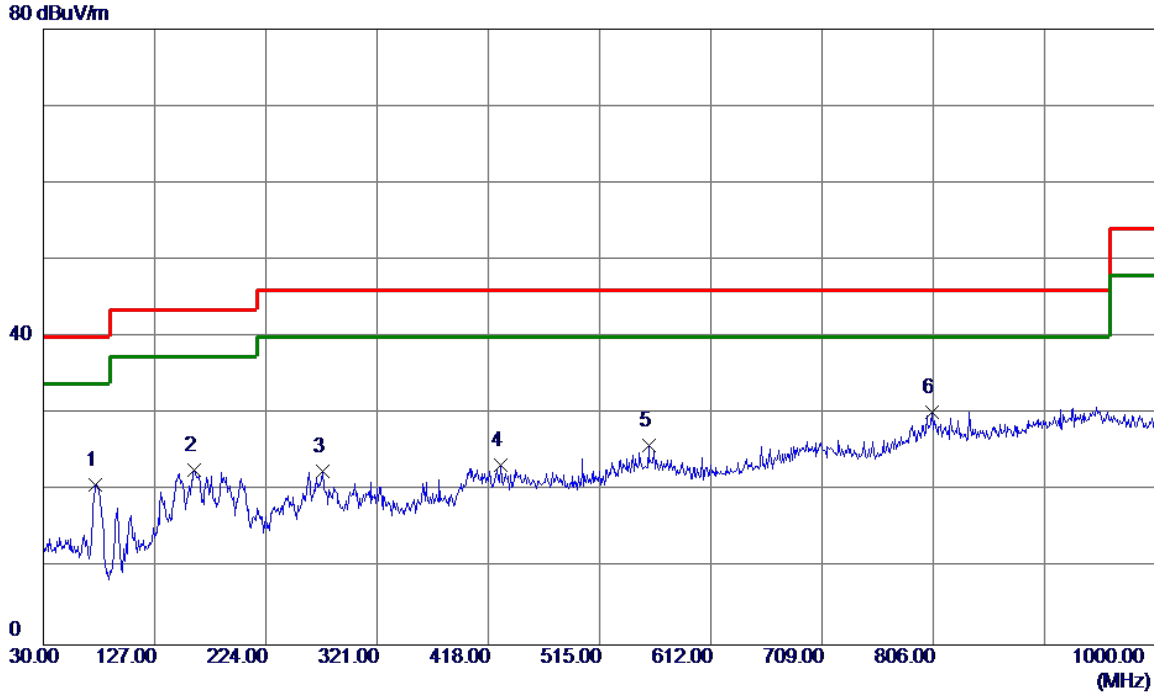

No.	Freq. MHz	Reading Level dBuV/m	Correct Factor dB	Measure ment dBuV/m	Limit dBuV/m	Margin dB	Detector	Comment
1	75.5899	39.27	-18.44	20.83	40.00	-19.17	Peak	
2	161.9200	33.47	-10.71	22.76	43.50	-20.74	Peak	
3	273.4700	34.67	-12.11	22.56	46.00	-23.44	Peak	
4	428.6700	31.65	-8.25	23.40	46.00	-22.60	Peak	
5	557.6800	31.49	-5.59	25.90	46.00	-20.10	Peak	
6 *	805.0300	31.31	-1.12	30.19	46.00	-15.81	Peak	

Test Mode: TX 2480MHz \_CH78\_1Mbps

### Vertical

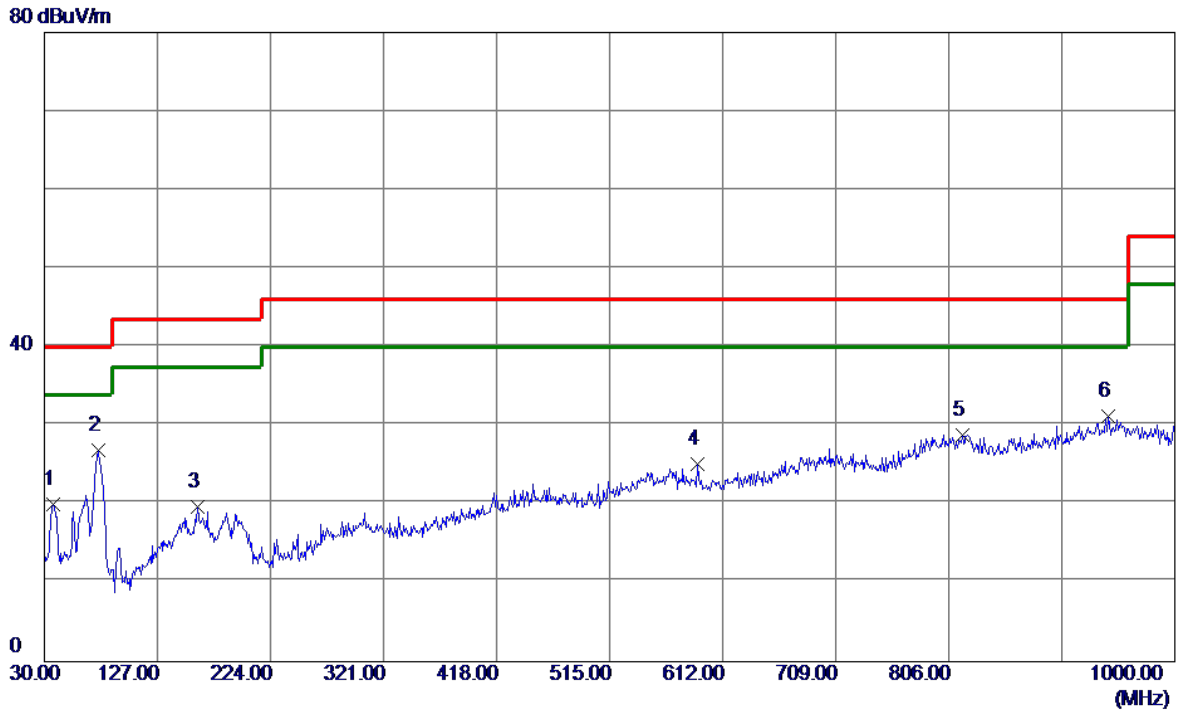

No.	Freq. MHz	Reading Level dBuV/m	Correct Factor dB	Measure ment dBuV/m	Limit dBuV/m	Margin dB	Detector	Comment
1	37.7599	34.68	-14.70	19.98	40.00	-20.02	Peak	
2 *	76.5600	45.38	-18.47	26.91	40.00	-13.09	Peak	
3	161.9200	30.42	-10.71	19.71	43.50	-23.79	Peak	
4	590.6599	31.27	-6.14	25.13	46.00	-20.87	Peak	
5	817.6400	30.13	-1.32	28.81	46.00	-17.19	Peak	
6	942.7700	30.04	1.12	31.16	46.00	-14.84	Peak	

Test Mode: TX 2480MHz \_CH78\_1Mbps

### Horizontal

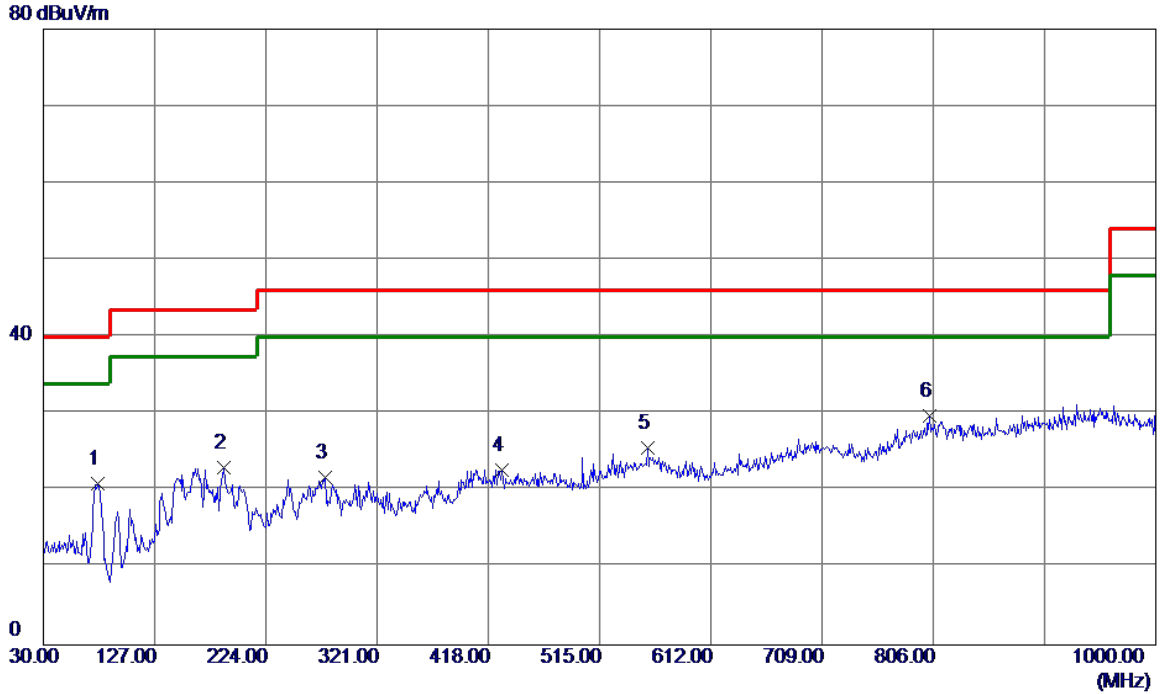

No.	Freq. MHz	Reading Level dBuV/m	Correct Factor dB	Measure ment dBuV/m	Limit dBuV/m	Margin dB	Detector	Comment
1	77.5300	39.51	-18.50	21.01	40.00	-18.99	Peak	
2	187.1400	36.96	-13.88	23.08	43.50	-20.42	Peak	
3	275.4100	33.65	-11.88	21.77	46.00	-24.23	Peak	
4	429.6400	30.91	-8.21	22.70	46.00	-23.30	Peak	
5	556.7100	31.17	-5.58	25.59	46.00	-20.41	Peak	
6 *	803.0900	30.86	-1.09	29.77	46.00	-16.23	Peak	

## APPENDIX D - RADIATED EMISSION (ABOVE 1000MHZ)



Test Mode : TX 2402MHz \_CH00\_1Mbps

Vertical

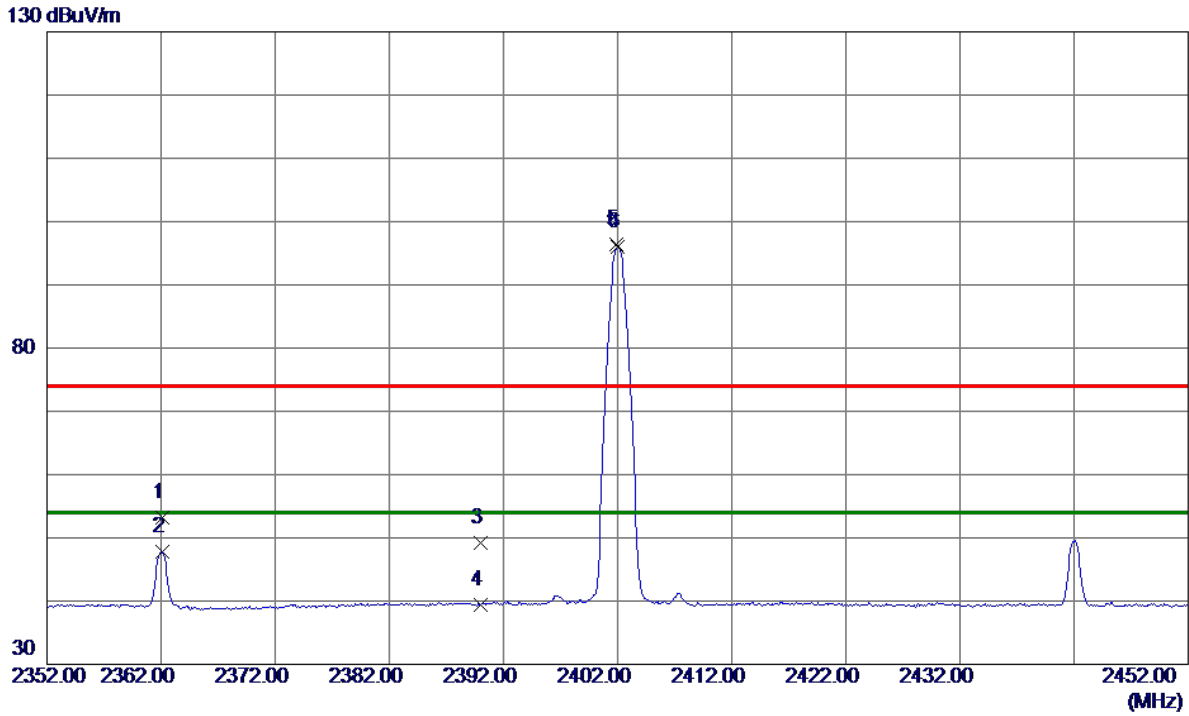

No.	Freq. MHz	Reading Level dBuV/m	Correct Factor dB	Measure ment dBuV/m	Limit dBuV/m	Margin dB	Detector	Comment
1	2362.1000	41.92	11.31	53.23	74.00	-20.77	Peak	
2	2362.1000	36.56	11.31	47.87	54.00	-6.13	AVG	
3	2390.0000	37.87	11.32	49.19	74.00	-24.81	Peak	
4	2390.0000	28.04	11.32	39.36	54.00	-14.64	AVG	
5	2401.9000	85.16	11.32	96.48	74.00	22.48	Peak	No Limit
6 *	2402.0000	84.69	11.32	96.01	54.00	42.01	AVG	No Limit

Test Mode : TX 2402MHz \_CH00\_1Mbps

Vertical

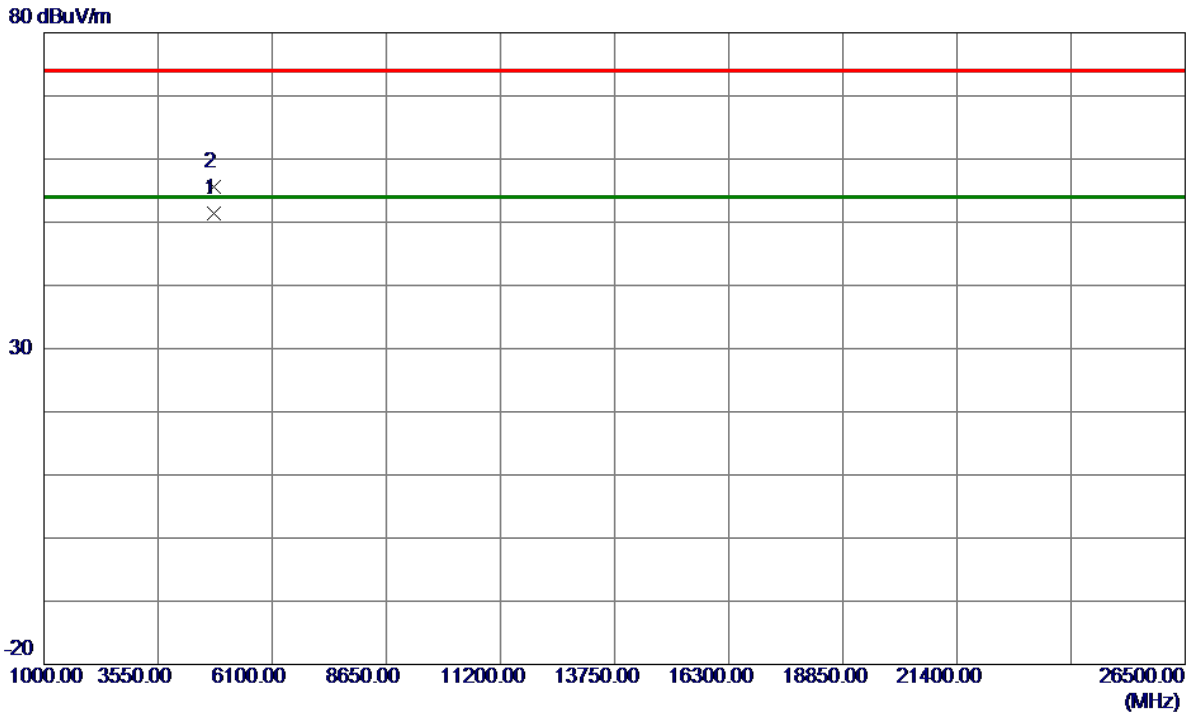

No.	Freq. MHz	Reading Level dBuV/m	Correct Factor dB	Measure ment dBuV/m	Limit dBuV/m	Margin dB	Detector	Comment
1 *	4803.9900	41.40	9.96	51.36	54.00	-2.64	AVG	
2	4804.0299	45.63	9.96	55.59	74.00	-18.41	Peak	

Test Mode : TX 2402MHz \_CH00\_1Mbps

Horizontal

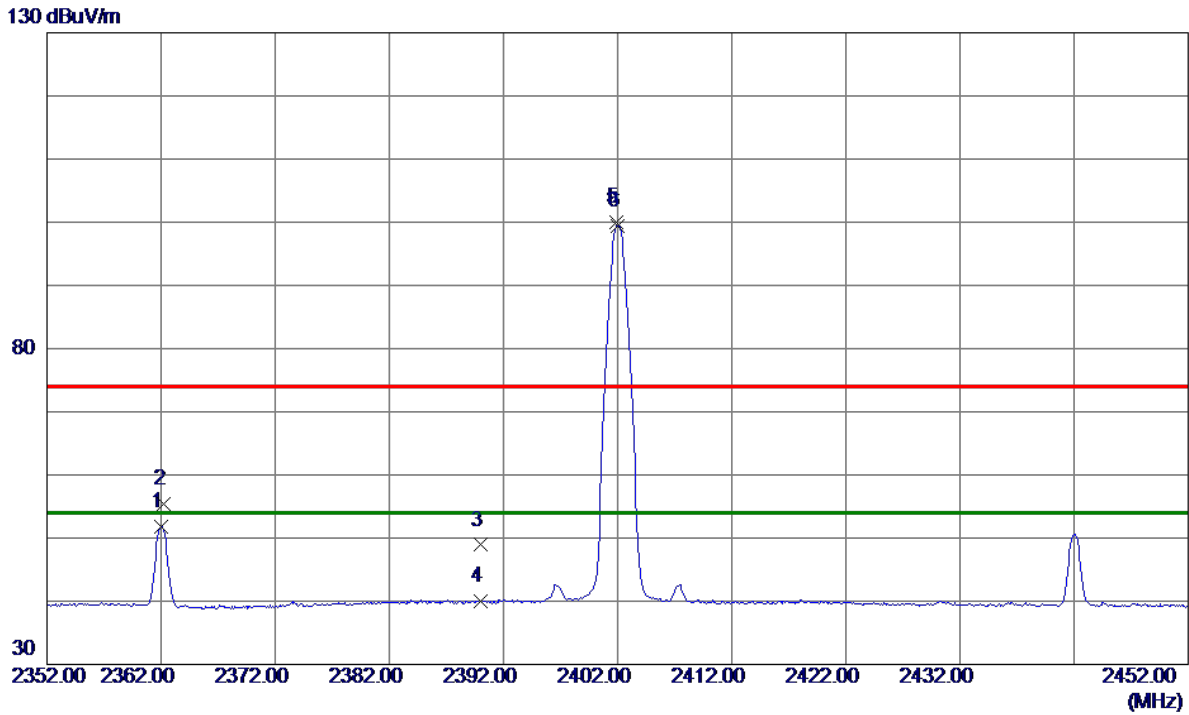

No.	Freq. MHz	Reading Level dBuV/m	Correct Factor dB	Measure ment dBuV/m	Limit dBuV/m	Margin dB	Detector	Comment
1	2362.0000	40.45	11.31	51.76	54.00	-2.24	AVG	
2	2362.2000	44.12	11.31	55.43	74.00	-18.57	Peak	
3	2390.0000	37.58	11.32	48.90	74.00	-25.10	Peak	
4	2390.0000	28.62	11.32	39.94	54.00	-14.06	AVG	
5	2401.9000	88.68	11.32	100.00	74.00	26.00	Peak	No Limit
6 *	2402.0000	88.16	11.32	99.48	54.00	45.48	AVG	No Limit

Test Mode : TX 2402MHz \_CH00\_1Mbps

### Horizontal

80 dBuV/m

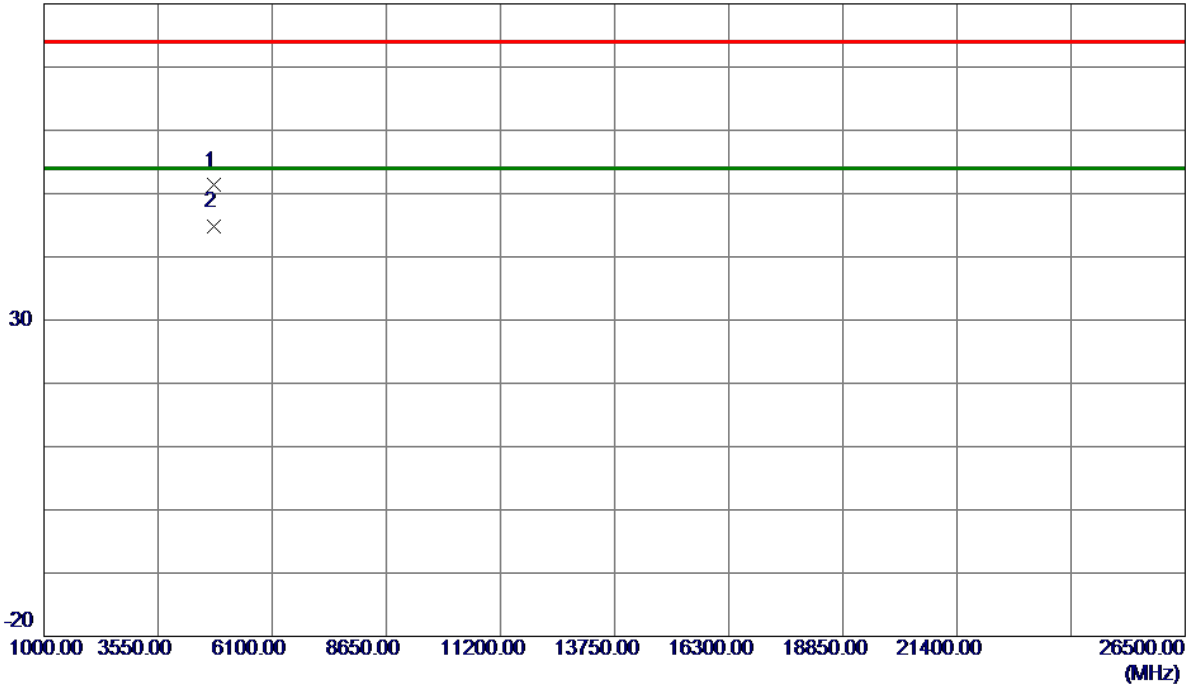

No.	Freq. MHz	Reading Level dBuV/m	Correct Factor dB	Measure ment dBuV/m	Limit dBuV/m	Margin dB	Detector	Comment
1	4803.9200	41.34	9.96	51.30	74.00	-22.70	Peak	
2 *	4804.0200	34.88	9.96	44.84	54.00	-9.16	AVG	

Test Mode : TX 2441MHz \_CH39\_1Mbps

**Vertical**

130 dBuV/m

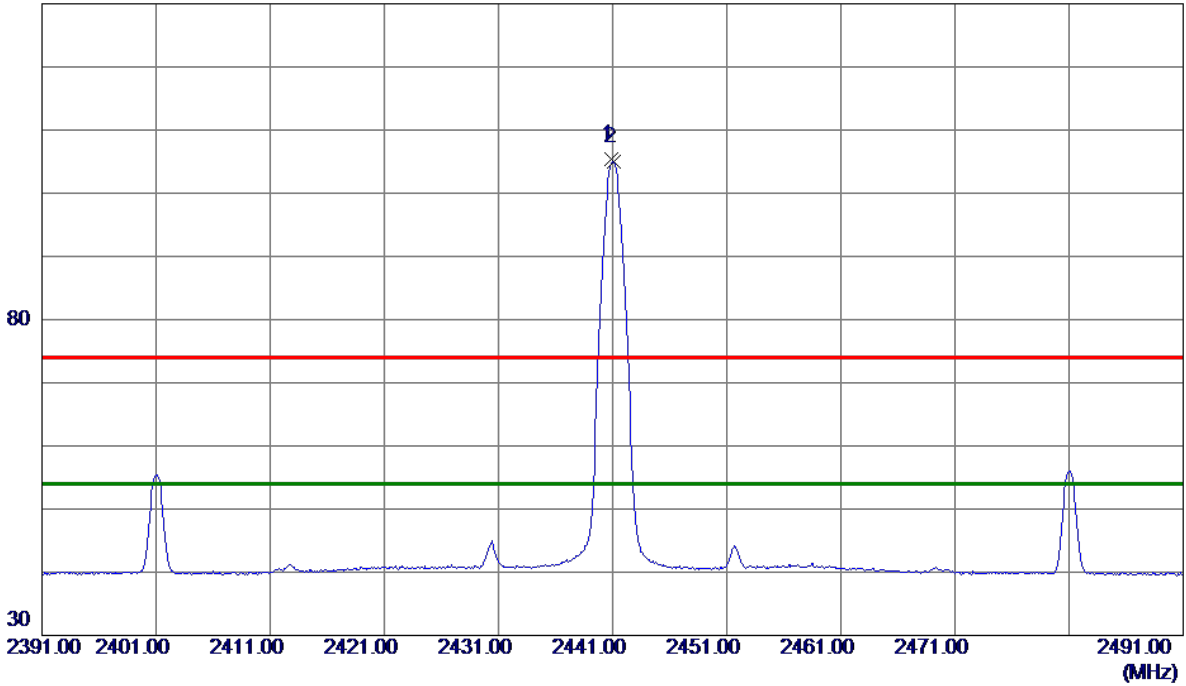

No.	Freq. MHz	Reading Level dBuV/m	Correct Factor dB	Measure ment dBuV/m	Limit dBuV/m	Margin dB	Detector	Comment
1	2440.9000	94.02	11.33	105.35	74.00	31.35	Peak	No Limit
2 *	2441.1000	93.62	11.33	104.95	54.00	50.95	AVG	No Limit

Test Mode : TX 2441MHz \_CH39\_1Mbps

Vertical

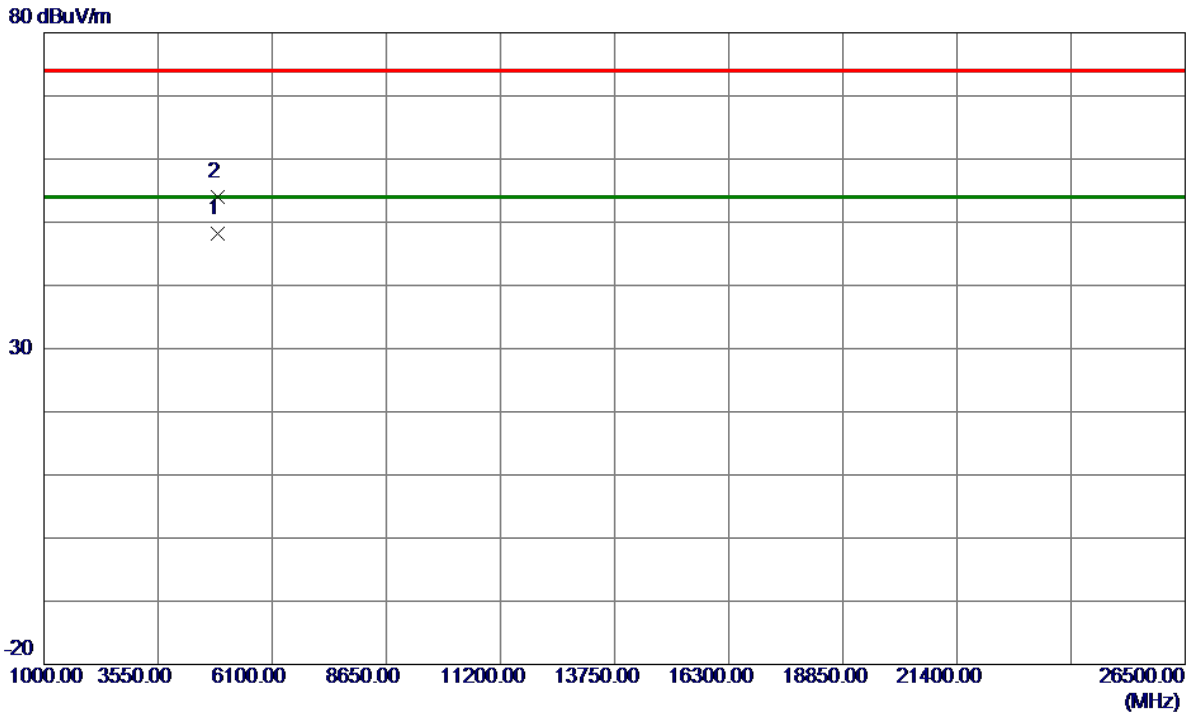

No.	Freq. MHz	Reading Level dBuV/m	Correct Factor dB	Measure ment dBuV/m	Limit dBuV/m	Margin dB	Detector	Comment
1 *	4881.9950	38.08	10.17	48.25	54.00	-5.75	AVG	
2	4882.0800	43.80	10.17	53.97	74.00	-20.03	Peak	

Test Mode : TX 2441MHz \_CH39\_1Mbps

**Horizontal**

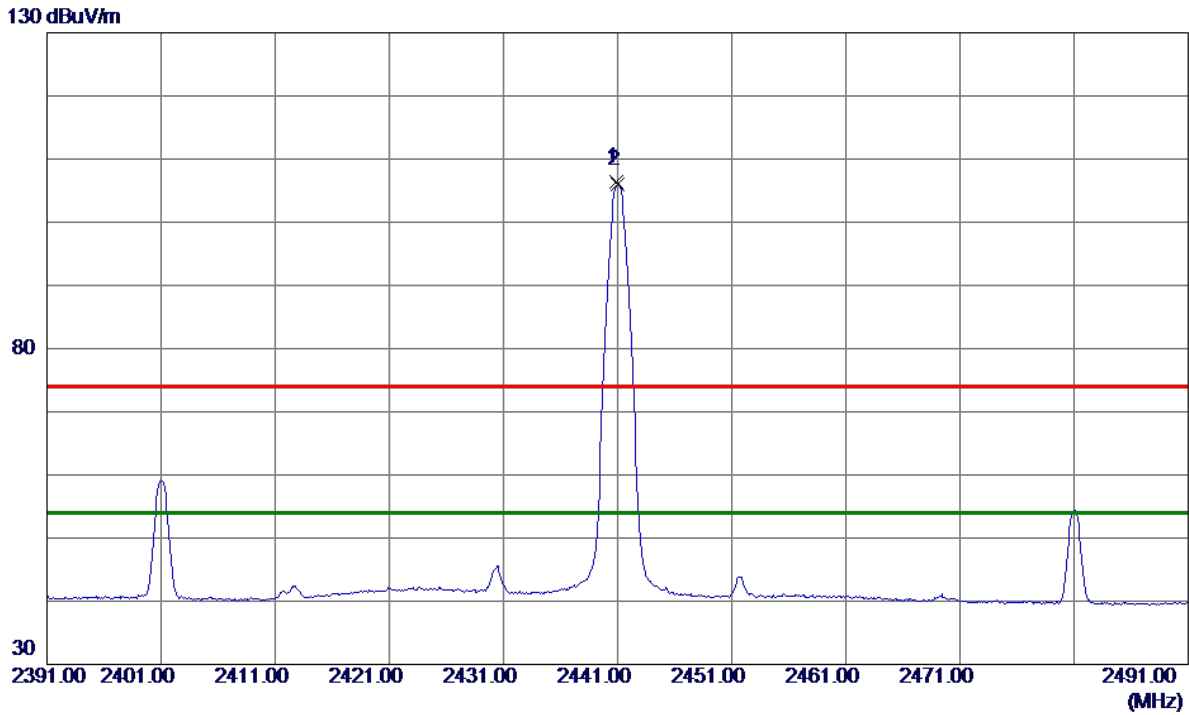

No.	Freq. MHz	Reading Level dBuV/m	Correct Factor dB	Measure ment dBuV/m	Limit dBuV/m	Margin dB	Detector	Comment
1	2440.9000	95.09	11.33	106.42	74.00	32.42	Peak	No Limit
2 *	2441.0000	94.73	11.33	106.06	54.00	52.06	AVG	No Limit

Test Mode : TX 2441MHz \_CH39\_1Mbps

Horizontal

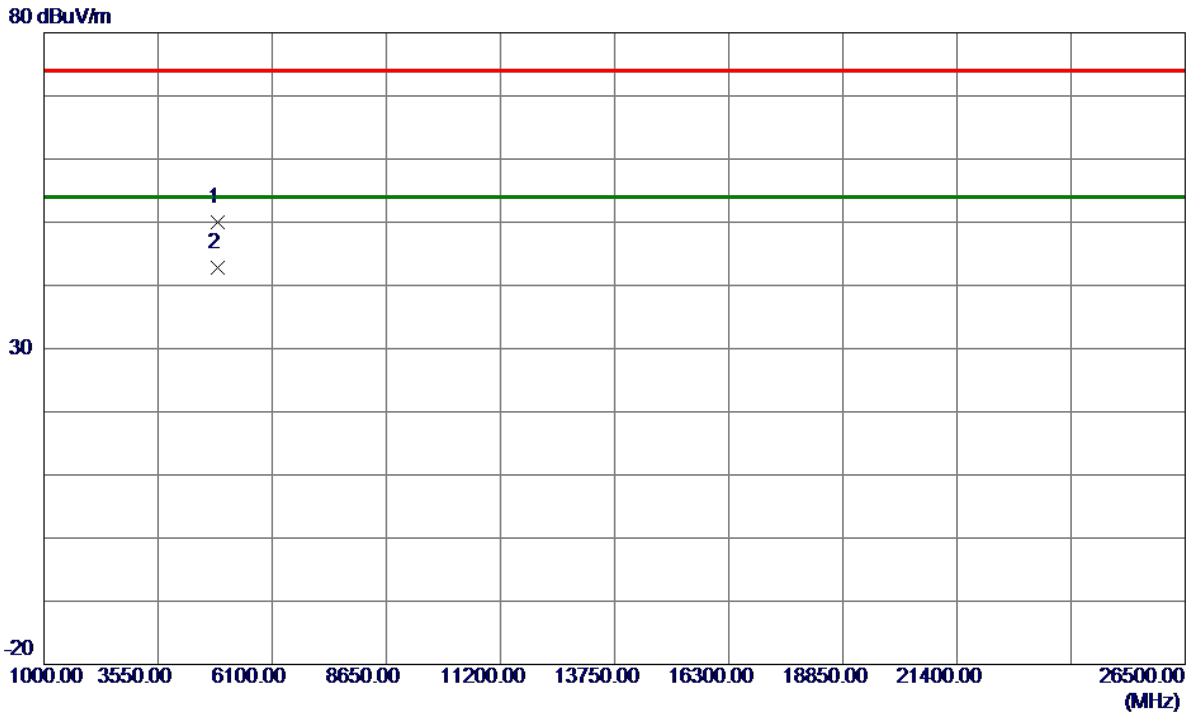

No.	Freq. MHz	Reading Level dBuV/m	Correct Factor dB	Measure ment dBuV/m	Limit dBuV/m	Margin dB	Detector	Comment
1	4881.8750	39.82	10.17	49.99	74.00	-24.01	Peak	
2 *	4881.9650	32.64	10.17	42.81	54.00	-11.19	AVG	



Test Mode : TX 2480MHz \_CH78\_1Mbps

Vertical

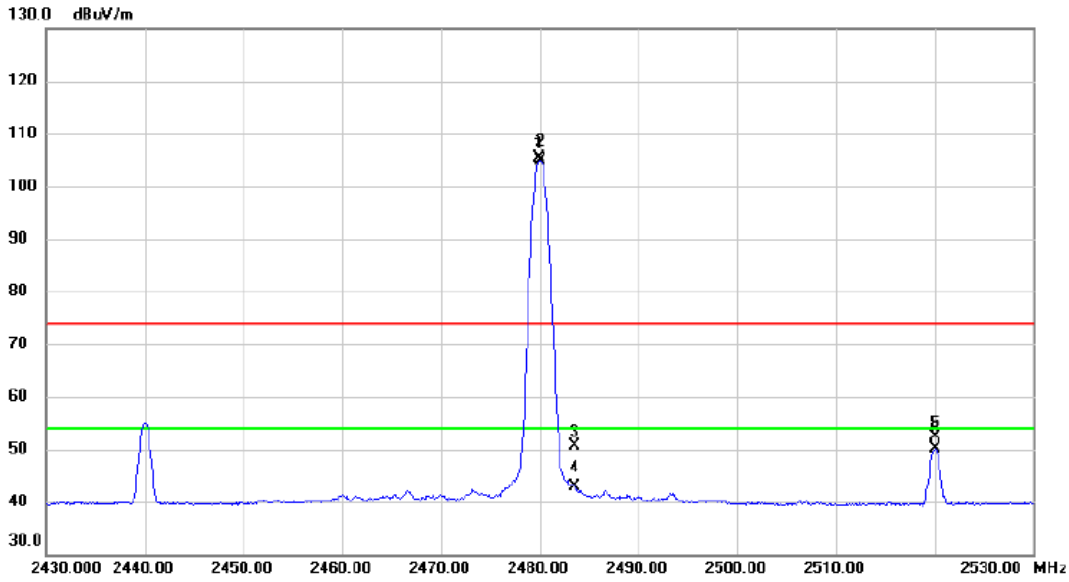

No.	Mk.	Freq. MHz	Reading Level dBuV	Correct Factor dB	Measure- ment dBuV/m	Limit dBuV/m	Margin dB	Detector	Comment
1	X	2479.900	93.95	11.34	105.29	74.00	31.29	peak	No Limit
2	*	2480.000	93.63	11.34	104.97	54.00	50.97	AVG	No Limit
3		2483.500	39.38	11.34	50.72	74.00	-23.28	peak	
4		2483.500	31.43	11.34	42.77	54.00	-11.23	AVG	
5		2520.000	40.79	11.50	52.29	74.00	-21.71	peak	
6		2520.000	38.61	11.50	50.11	54.00	-3.89	AVG	

Test Mode : TX 2480MHz \_CH78\_1Mbps

Vertical

80 dBuV/m

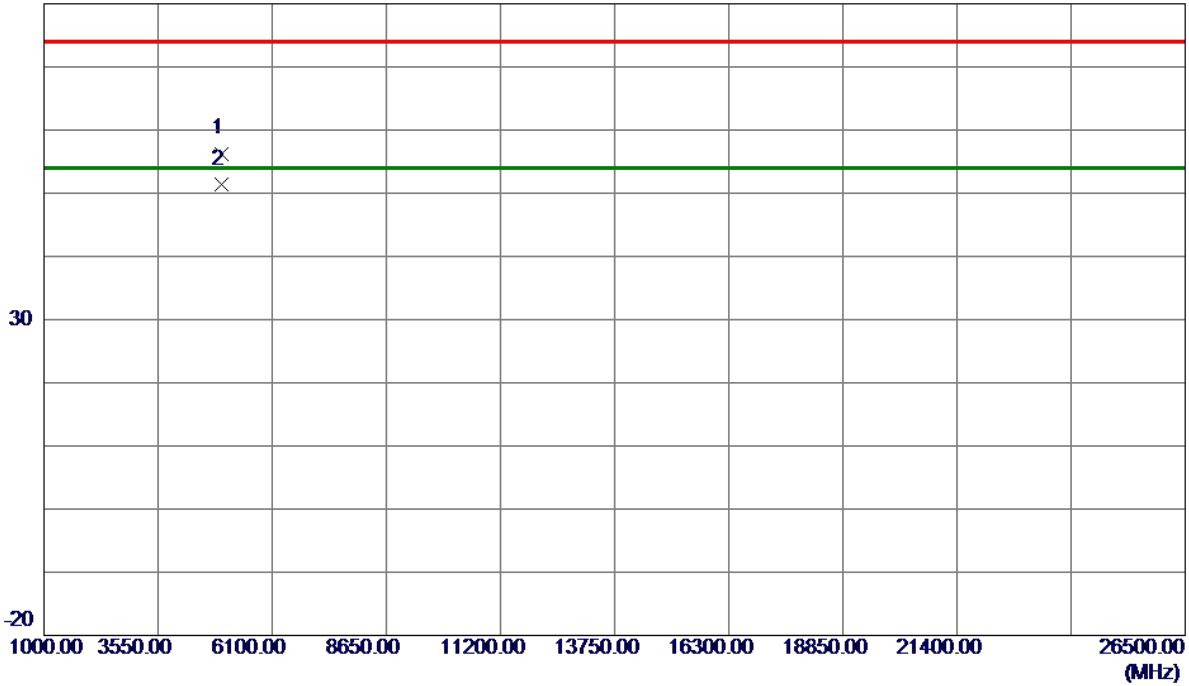

No.	Freq. MHz	Reading Level dBuV/m	Correct Factor dB	Measure ment dBuV/m	Limit dBuV/m	Margin dB	Detector	Comment
1	4959.9650	45.92	10.38	56.30	74.00	-17.70	Peak	
2 *	4959.9950	40.96	10.38	51.34	54.00	-2.66	AVG	

Test Mode : TX 2480MHz \_CH78\_1Mbps

### Horizontal

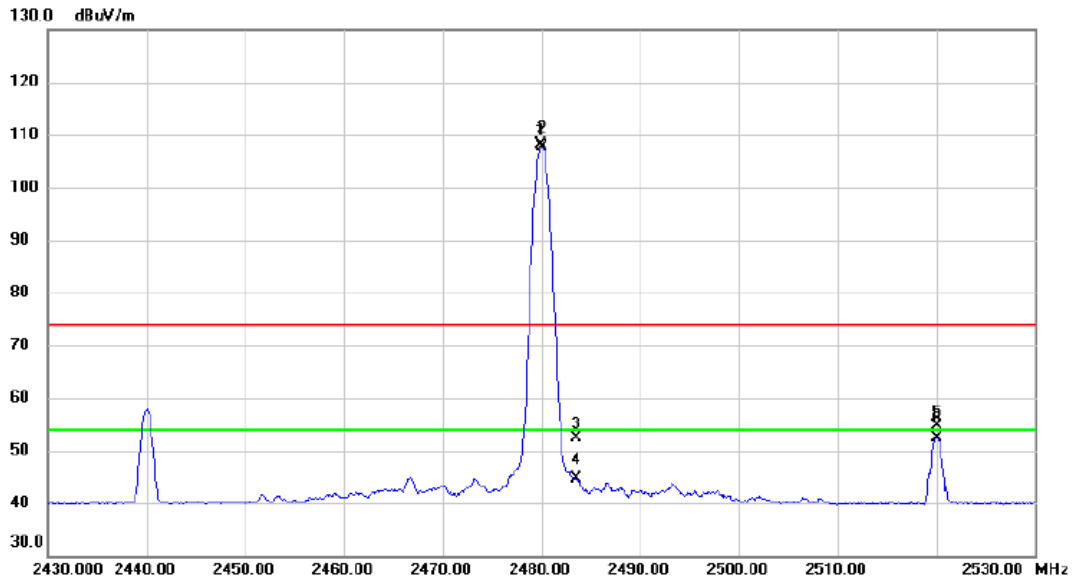

No.	Mk.	Freq. MHz	Reading Level dBuV	Correct Factor dB	Measure- ment dBuV/m	Limit dBuV/m	Margin dB	Detector	Comment
1	X	2479.900	96.69	11.34	108.03	74.00	34.03	peak	No Limit
2	*	2480.000	96.31	11.34	107.65	54.00	53.65	AVG	No Limit
3		2483.500	41.03	11.34	52.37	74.00	-21.63	peak	
4		2483.500	33.40	11.34	44.74	54.00	-9.26	AVG	
5		2520.000	43.08	11.50	54.58	74.00	-19.42	peak	
6		2520.000	40.99	11.50	52.49	54.00	-1.51	AVG	

Test Mode : TX 2480MHz \_CH78\_1Mbps

Horizontal

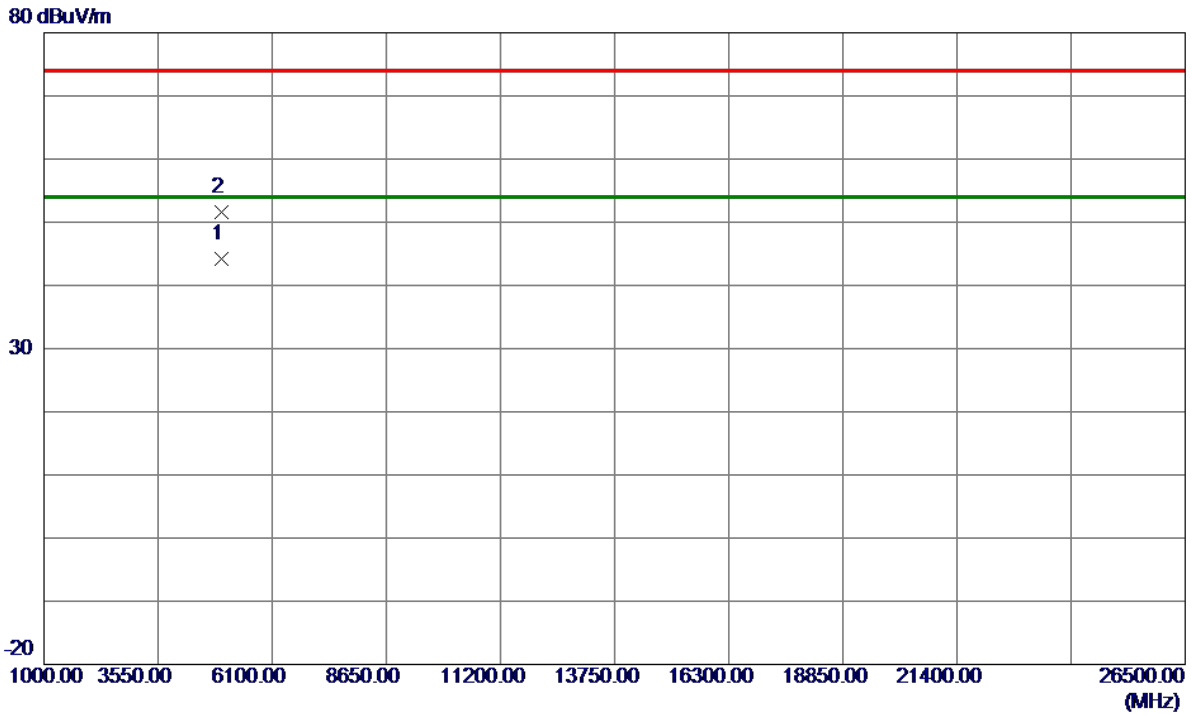

No.	Freq. MHz	Reading Level dBuV/m	Correct Factor dB	Measure ment dBuV/m	Limit dBuV/m	Margin dB	Detector	Comment
1 *	4960.0500	33.88	10.38	44.26	54.00	-9.74	AVG	
2	4960.1950	41.26	10.38	51.64	74.00	-22.36	Peak	

Test Mode : TX 2402MHz \_CH00\_3Mbps

Vertical

130 dBuV/m

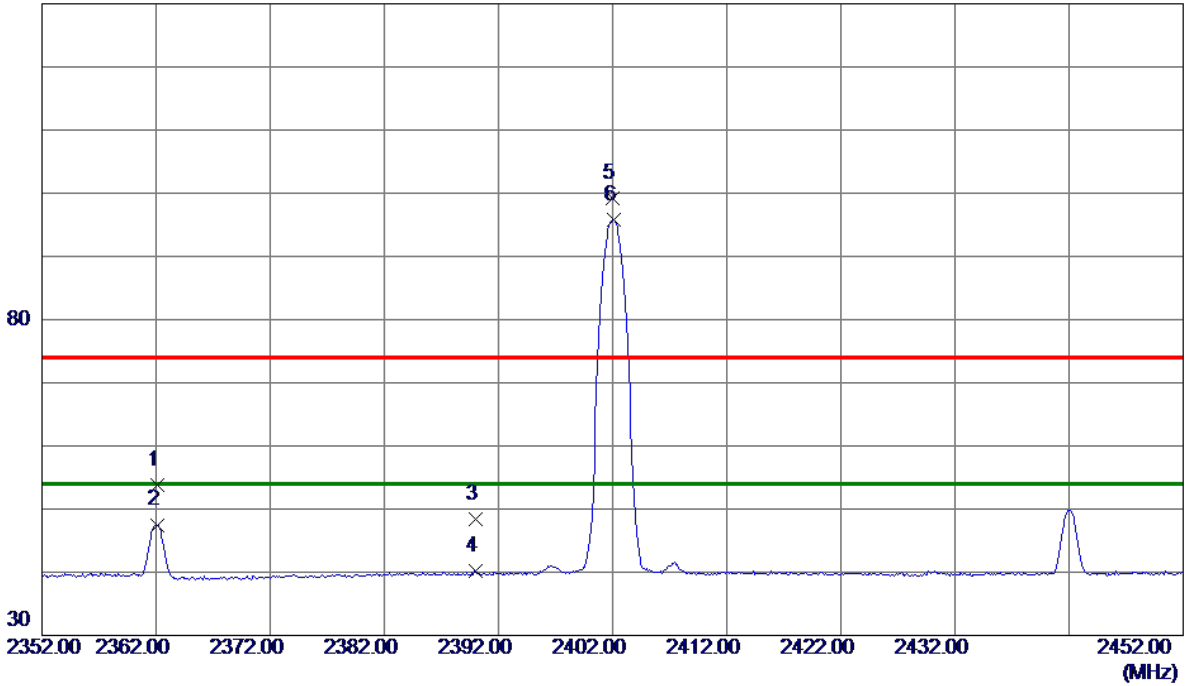

No.	Freq. MHz	Reading Level dBuV/m	Correct Factor dB	Measure ment dBuV/m	Limit dBuV/m	Margin dB	Detector	Comment
1	2362.1000	42.54	11.31	53.85	74.00	-20.15	Peak	
2	2362.1000	36.19	11.31	47.50	54.00	-6.50	AVG	
3	2390.0000	37.17	11.32	48.49	74.00	-25.51	Peak	
4	2390.0000	28.85	11.32	40.17	54.00	-13.83	AVG	
5	2402.0000	87.93	11.32	99.25	74.00	25.25	Peak	No Limit
6 *	2402.1000	84.41	11.32	95.73	54.00	41.73	AVG	No Limit

Test Mode : TX 2402MHz \_CH00\_3Mbps

Vertical

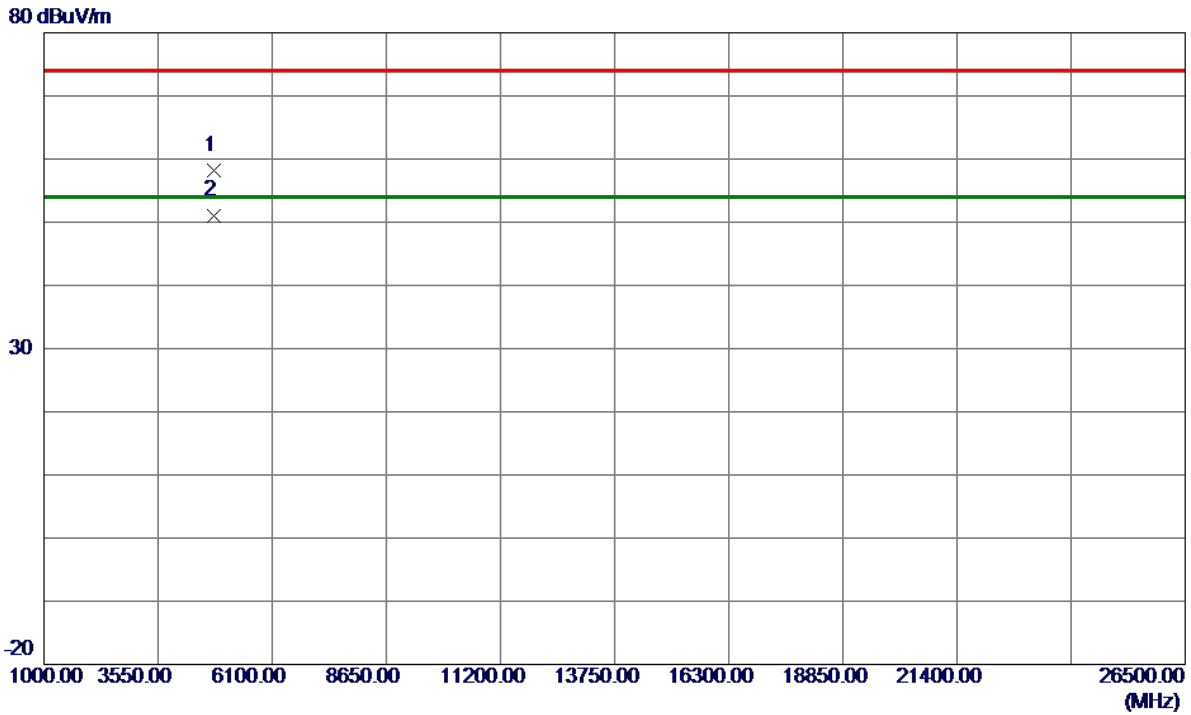

No.	Freq. MHz	Reading Level dBuV/m	Correct Factor dB	Measure ment dBuV/m	Limit dBuV/m	Margin dB	Detector	Comment
1	4804.0299	48.28	9.96	58.24	74.00	-15.76	Peak	
2 *	4804.0700	41.14	9.96	51.10	54.00	-2.90	AVG	

Test Mode : TX 2402MHz \_CH00\_3Mbps

Horizontal

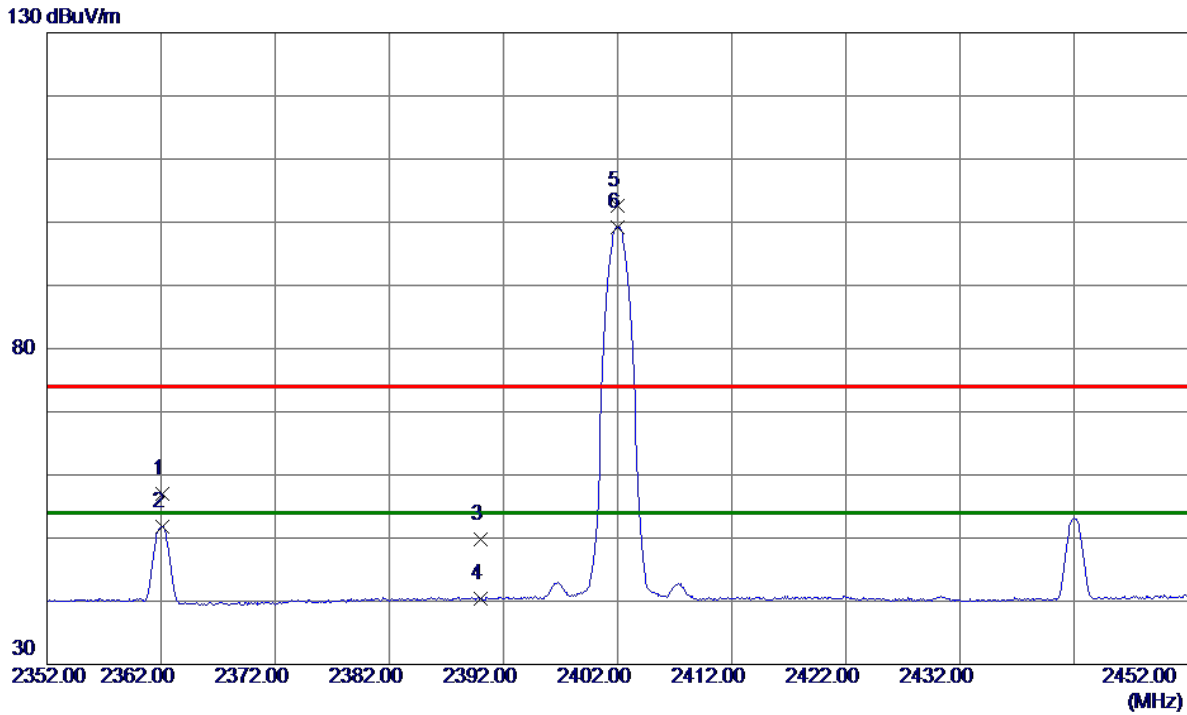

No.	Freq. MHz	Reading Level dBuV/m	Correct Factor dB	Measure ment dBuV/m	Limit dBuV/m	Margin dB	Detector	Comment
1	2362.1000	45.64	11.31	56.95	74.00	-17.05	Peak	
2	2362.1000	40.51	11.31	51.82	54.00	-2.18	AVG	
3	2390.0000	38.51	11.32	49.83	74.00	-24.17	Peak	
4	2390.0000	29.14	11.32	40.46	54.00	-13.54	AVG	
5	2402.0000	91.35	11.32	102.67	74.00	28.67	Peak	No Limit
6 *	2402.0000	87.96	11.32	99.28	54.00	45.28	AVG	No Limit

Test Mode : TX 2402MHz \_CH00\_3Mbps

Horizontal

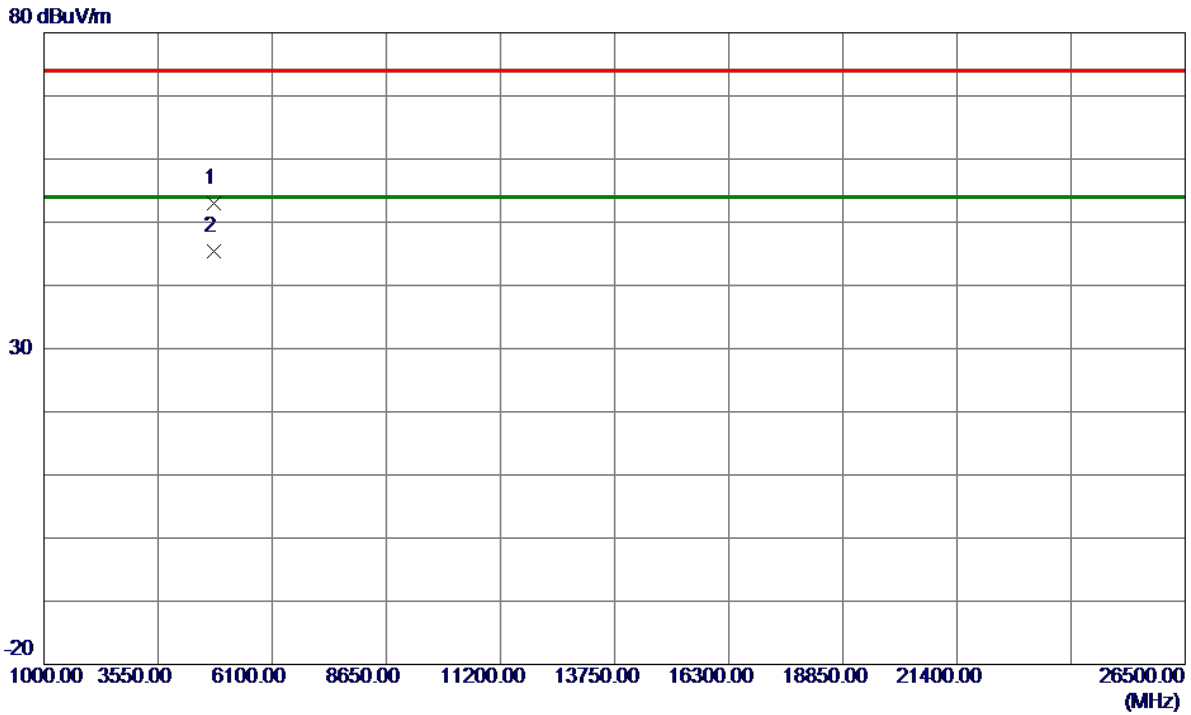

No.	Freq. MHz	Reading Level dBuV/m	Correct Factor dB	Measure ment dBuV/m	Limit dBuV/m	Margin dB	Detector	Comment
1	4803.8400	43.01	9.96	52.97	74.00	-21.03	Peak	
2 *	4803.9700	35.38	9.96	45.34	54.00	-8.66	AVG	



Test Mode : TX 2441MHz \_CH39\_3Mbps

**Vertical**

130 dBuV/m

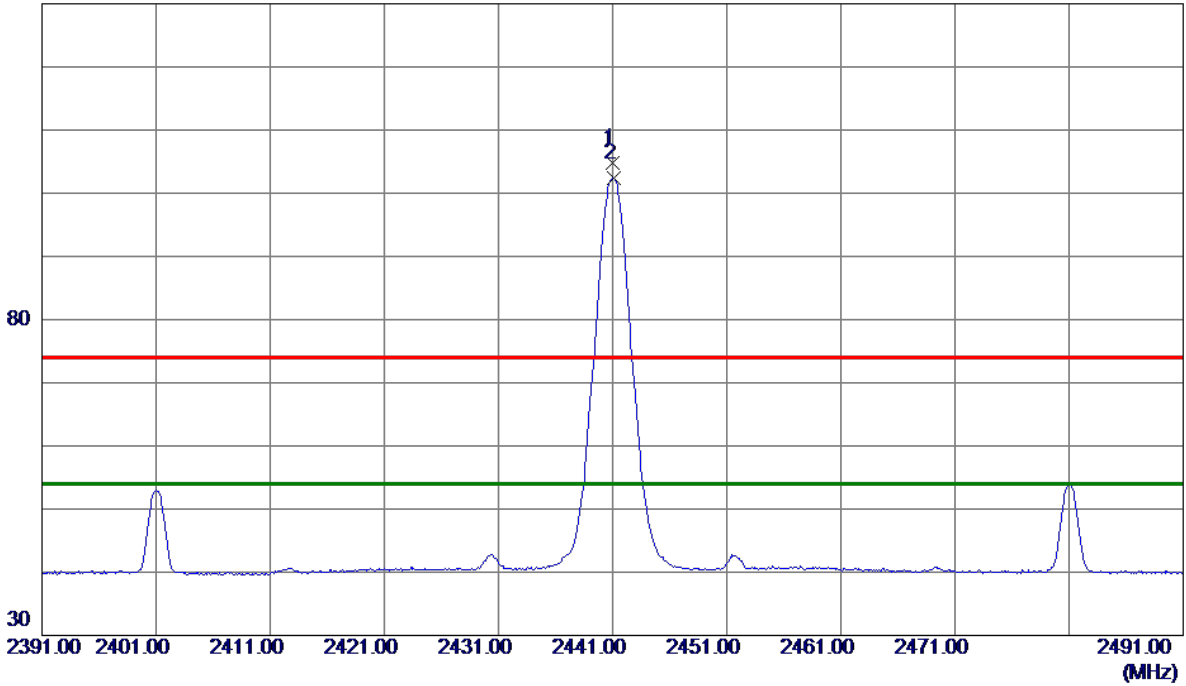

No.	Freq. MHz	Reading Level dBuV/m	Correct Factor dB	Measure ment dBuV/m	Limit dBuV/m	Margin dB	Detector	Comment
1	2441.0000	93.55	11.33	104.88	74.00	30.88	Peak	No Limit
2 *	2441.1000	91.00	11.33	102.33	54.00	48.33	AVG	No Limit

Test Mode : TX 2441MHz \_CH39\_3Mbps

Vertical

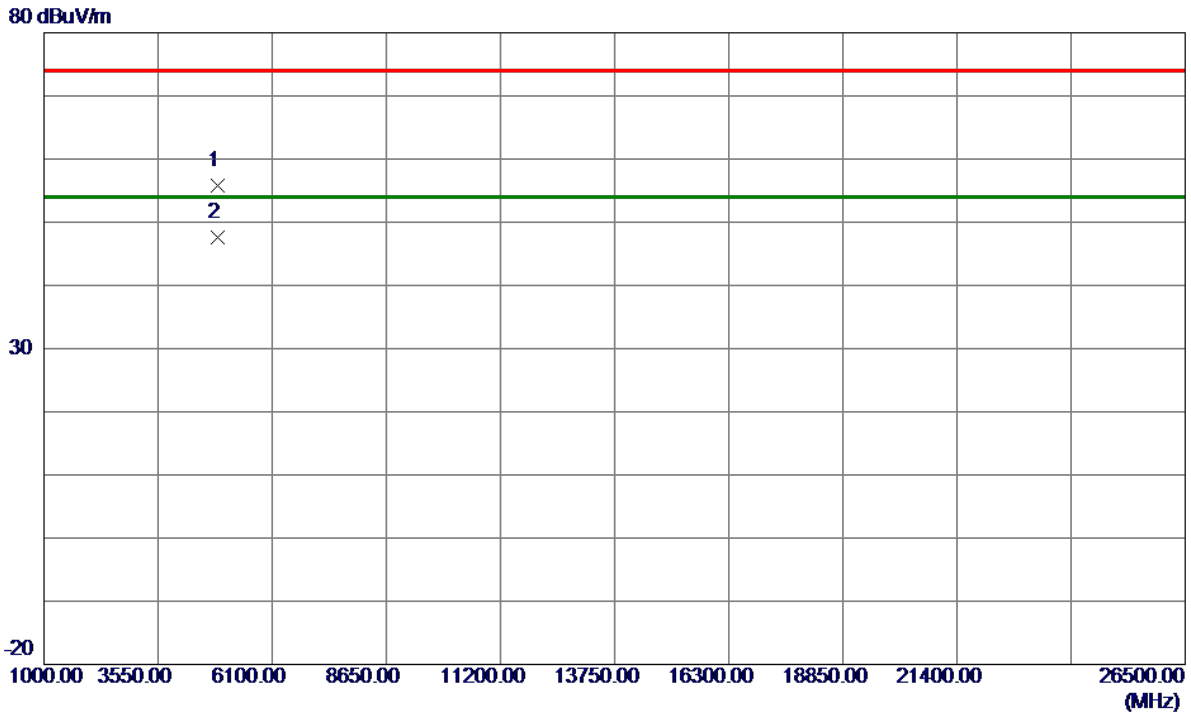

No.	Freq. MHz	Reading Level dBuV/m	Correct Factor dB	Measure ment dBuV/m	Limit dBuV/m	Margin dB	Detector	Comment
1	4882.0050	45.67	10.17	55.84	74.00	-18.16	Peak	
2 *	4882.0450	37.52	10.17	47.69	54.00	-6.31	AVG	

Test Mode : TX 2441MHz \_CH39\_3Mbps

Horizontal

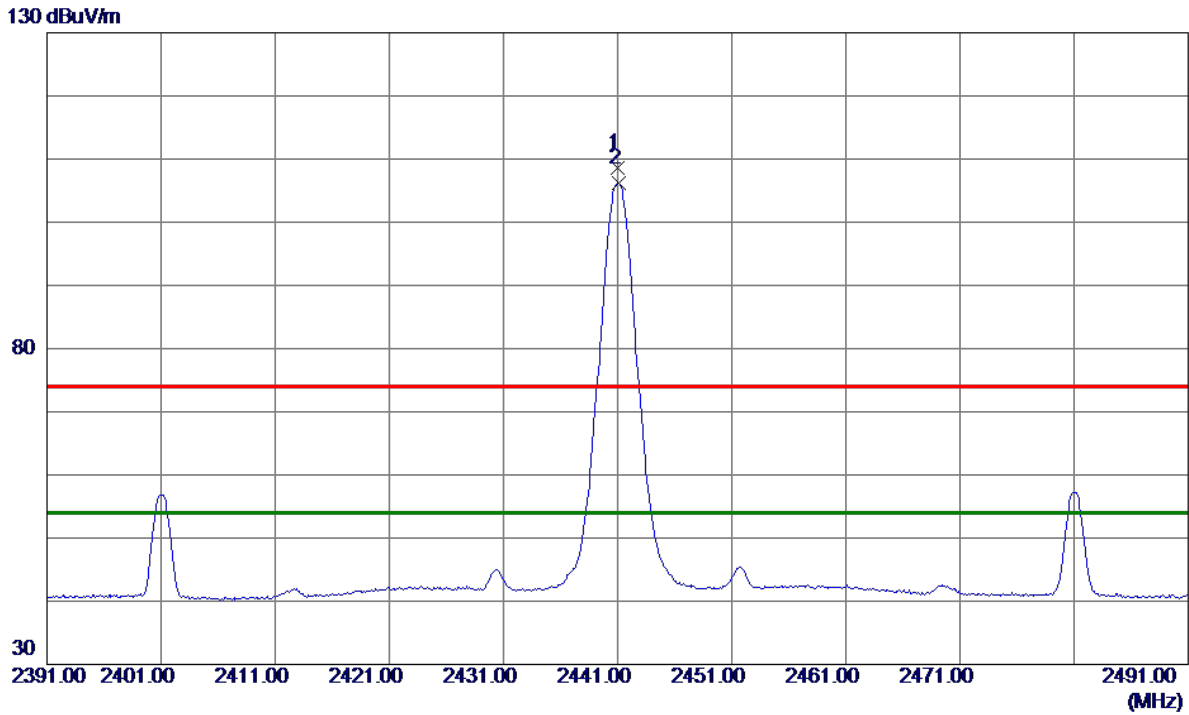

No.	Freq. MHz	Reading Level dBuV/m	Correct Factor dB	Measure ment dBuV/m	Limit dBuV/m	Margin dB	Detector	Comment
1	2441.0000	97.32	11.33	108.65	74.00	34.65	Peak	No Limit
2 *	2441.1000	94.79	11.33	106.12	54.00	52.12	AVG	No Limit

Test Mode : TX 2441MHz \_CH39\_3Mbps

Horizontal

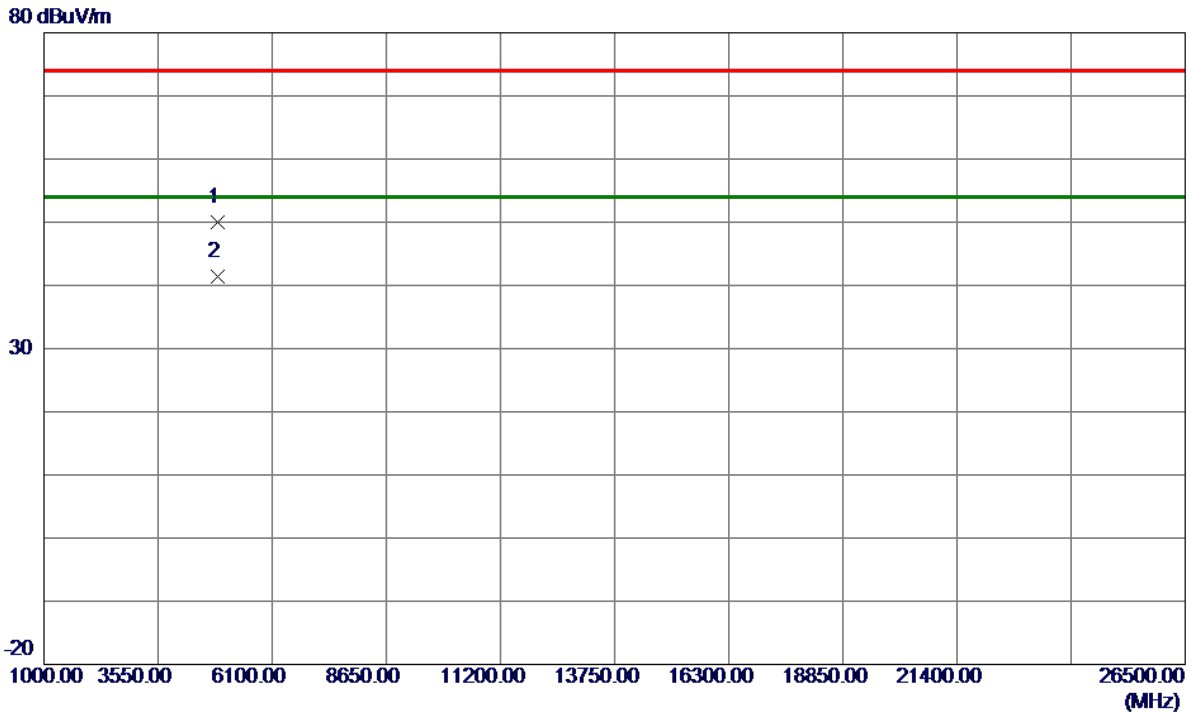

No.	Freq. MHz	Reading Level dBuV/m	Correct Factor dB	Measure ment dBuV/m	Limit dBuV/m	Margin dB	Detector	Comment
1	4882.0450	39.89	10.17	50.06	74.00	-23.94	Peak	
2 *	4882.0950	31.20	10.17	41.37	54.00	-12.63	AVG	

Test Mode : TX 2480MHz \_CH78\_3Mbps

Vertical

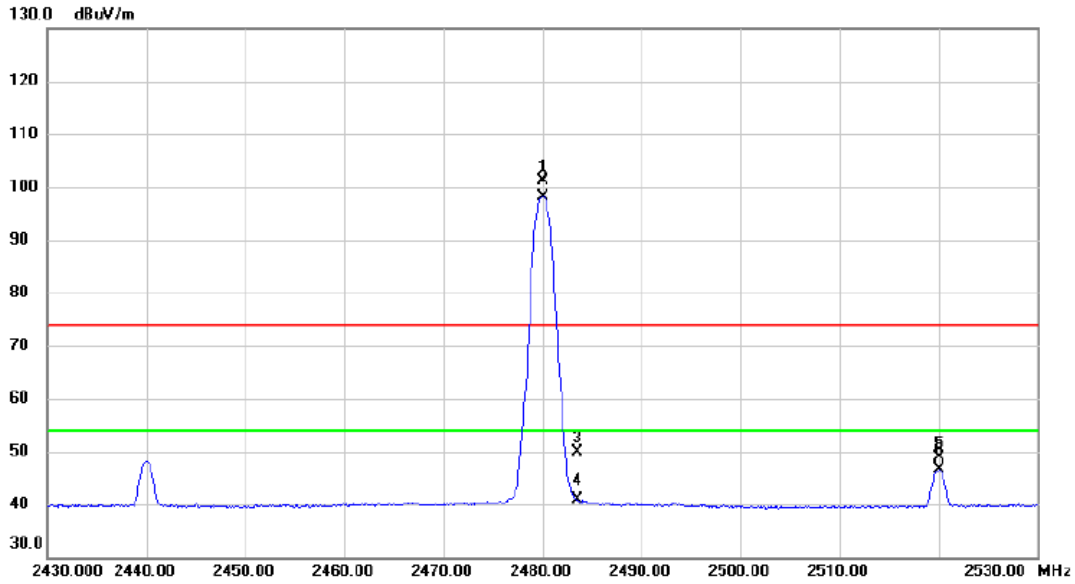

No.	Mk.	Freq. MHz	Reading Level dBuV	Correct Factor dB	Measure- ment dBuV/m	Limit dBuV/m	Margin dB	Detector	Comment
1	X	2480.000	89.81	11.34	101.15	74.00	27.15	peak	No Limit
2	*	2480.100	86.85	11.34	98.19	54.00	44.19	AVG	No Limit
3		2483.500	38.43	11.34	49.77	74.00	-24.23	peak	
4		2483.500	29.43	11.34	40.77	54.00	-13.23	AVG	
5		2520.100	37.29	11.50	48.79	74.00	-25.21	peak	
6		2520.100	35.14	11.50	46.64	54.00	-7.36	AVG	

Test Mode : TX 2480MHz \_CH78\_3Mbps

Vertical

80 dBuV/m

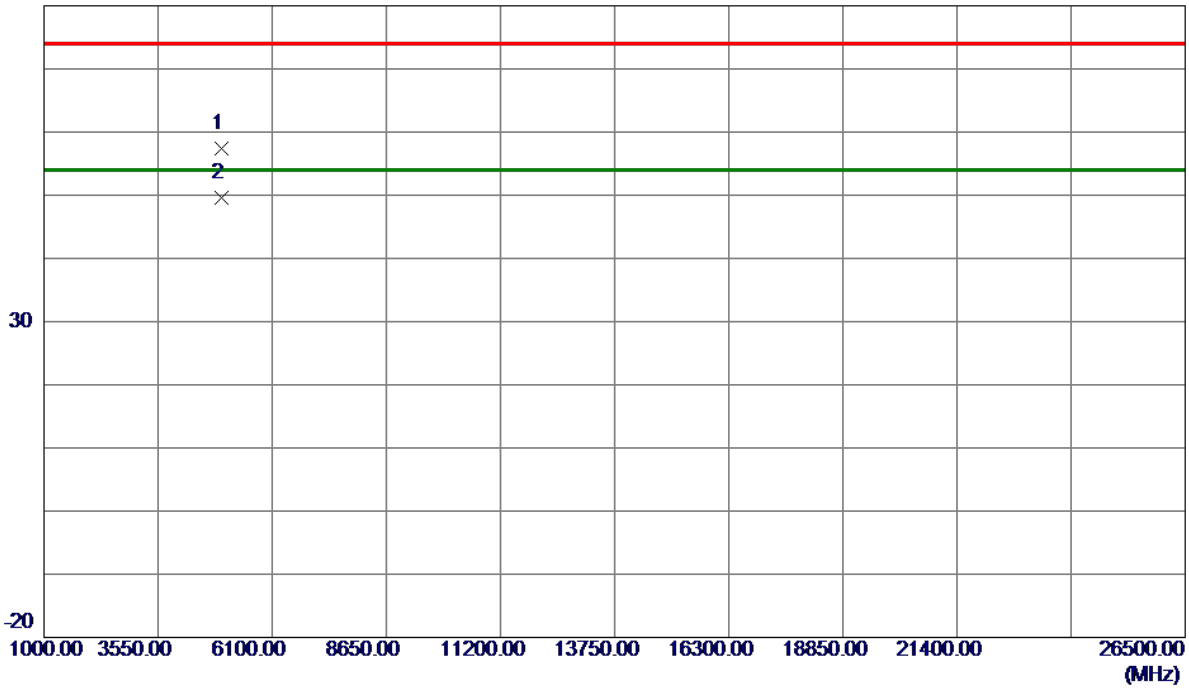

No.	Freq. MHz	Reading Level dBuV/m	Correct Factor dB	Measure ment dBuV/m	Limit dBuV/m	Margin dB	Detector	Comment
1	4959.9750	47.10	10.38	57.48	74.00	-16.52	Peak	
2 *	4959.9800	39.13	10.38	49.51	54.00	-4.49	AVG	

Test Mode : TX 2480MHz \_CH78\_3Mbps

Horizontal

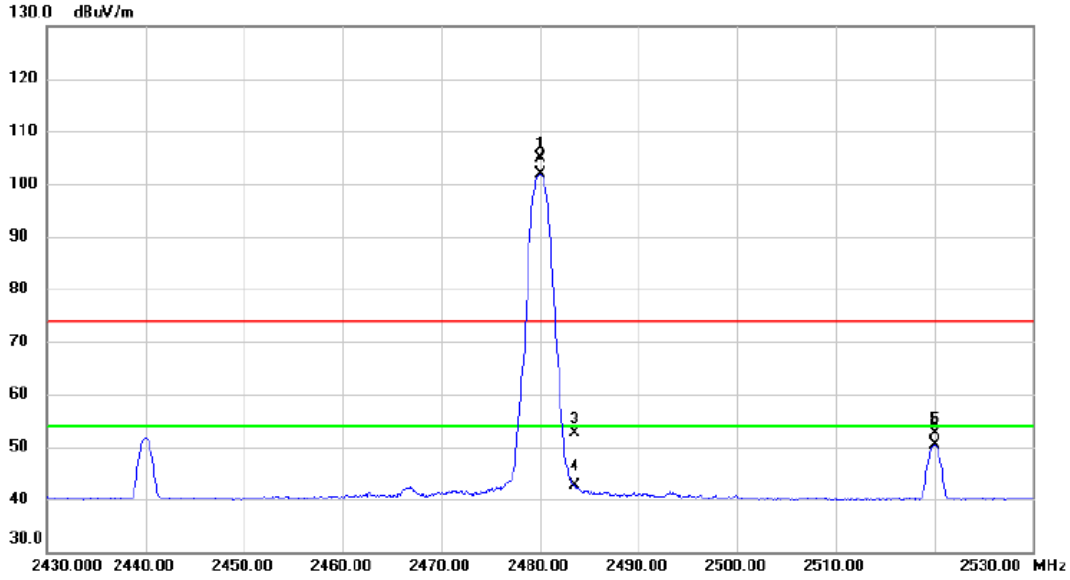

No.	Mk.	Freq. MHz	Reading Level dBuV	Correct Factor dB	Measure- ment dBuV/m	Limit dBuV/m	Margin dB	Detector	Comment
1	X	2480.000	93.45	11.34	104.79	74.00	30.79	peak	No Limit
2	*	2480.000	90.56	11.34	101.90	54.00	47.90	AVG	No Limit
3		2483.500	41.28	11.34	52.62	74.00	-21.38	peak	
4		2483.500	31.24	11.34	42.58	54.00	-11.42	AVG	
5		2520.100	41.19	11.50	52.69	74.00	-21.31	peak	
6		2520.100	39.00	11.50	50.50	54.00	-3.50	AVG	

Test Mode : TX 2480MHz \_CH78\_3Mbps

Horizontal

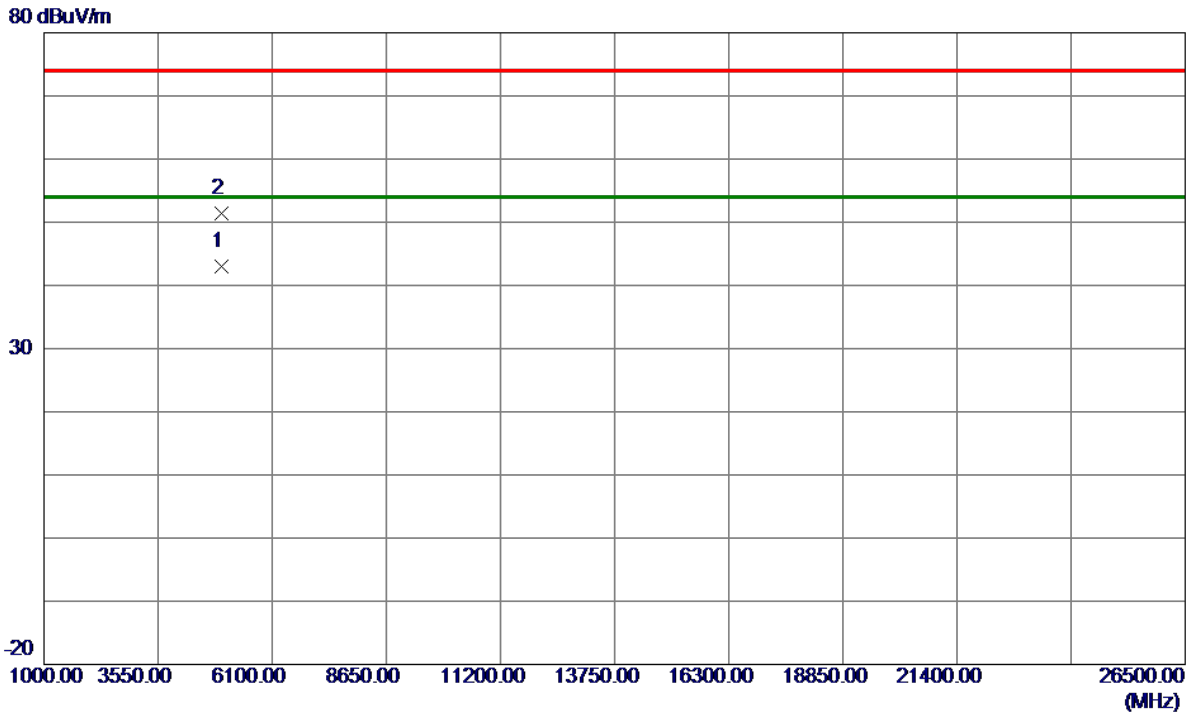

No.	Freq. MHz	Reading Level dBuV/m	Correct Factor dB	Measure ment dBuV/m	Limit dBuV/m	Margin dB	Detector	Comment
1 *	4959.9250	32.67	10.38	43.05	54.00	-10.95	AVG	
2	4960.0750	41.08	10.38	51.46	74.00	-22.54	Peak	



## APPENDIX E - NUMBER OF HOPPING CHANNEL

**Test Mode**                      **Hopping Mode\_1Mbps**  
Number of Hopping Channel                      79

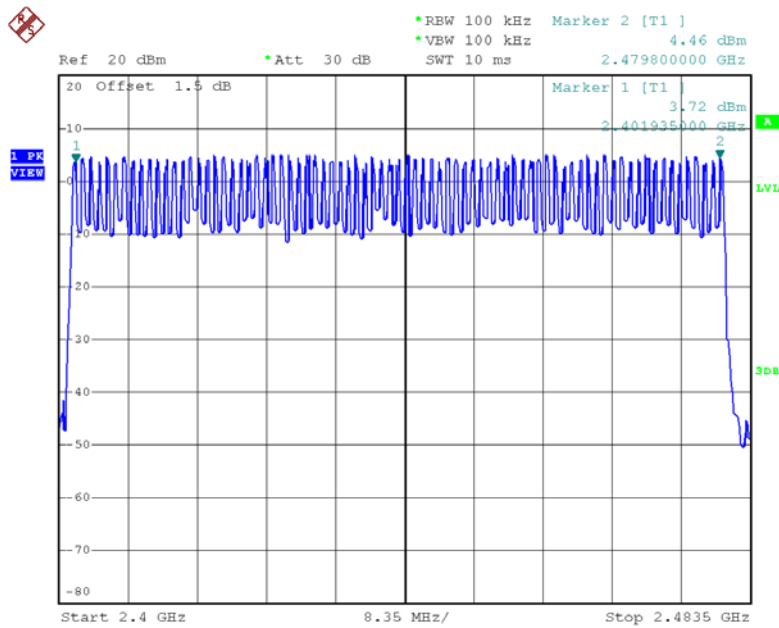

Date: 2.JUL.2018 18:46:31

**Test Mode**                      **Hopping Mode\_3Mbps**  
Number of Hopping Channel                      79

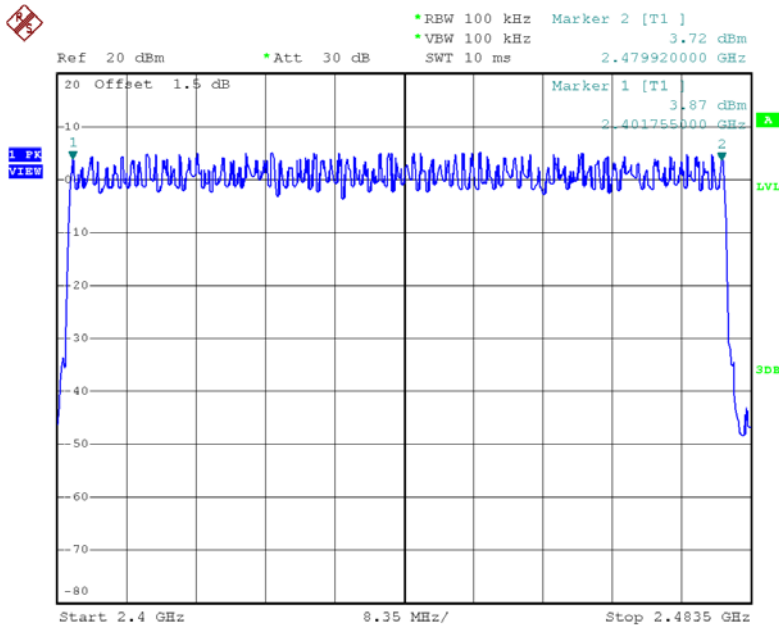

Date: 2.JUL.2018 19:25:04

## APPENDIX F - AVERAGE TIME OF OCCUPANCY

Test Mode :	TX Mode_1Mbps
-------------	---------------

Data Packet	Frequency (MHz)	Pulse Duration (ms)	Dwell Time (s)	Limits (s)	Test Result
DH5	2402	2.9200	0.3115	0.4000	Pass
DH3	2402	1.6600	0.2656	0.4000	Pass
DH1	2402	0.3950	0.1264	0.4000	Pass
DH5	2441	2.8800	0.3072	0.4000	Pass
DH3	2441	1.6600	0.2656	0.4000	Pass
DH1	2441	0.3950	0.1264	0.4000	Pass
DH5	2480	2.9200	0.3115	0.4000	Pass
DH3	2480	1.6600	0.2656	0.4000	Pass
DH1	2480	0.3950	0.1264	0.4000	Pass

**CH00-DH1**

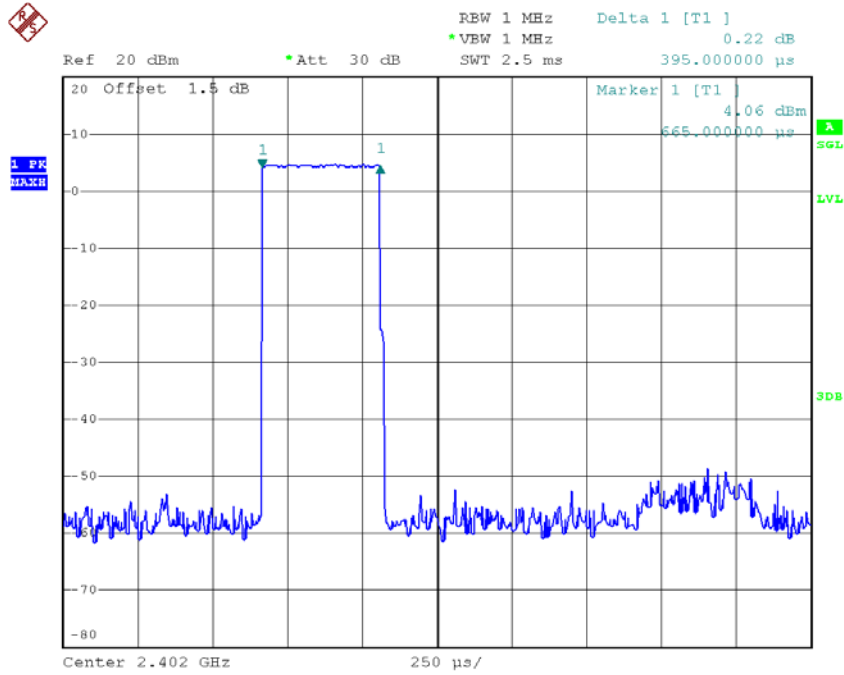

Date: 2.JUL.2018 18:41:13

**CH00-DH3**

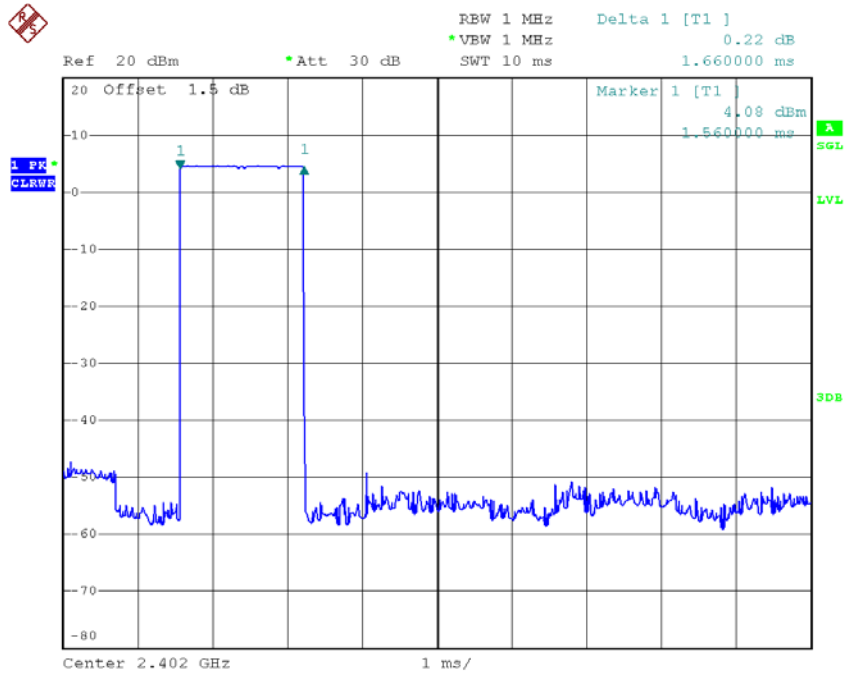

Date: 2.JUL.2018 18:56:12

### CH00-DH5

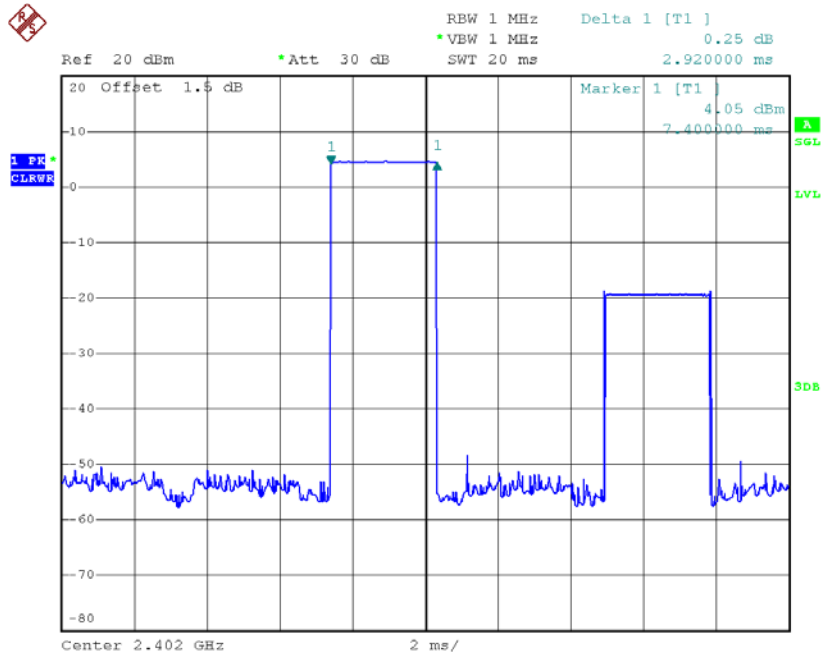

Date: 2.JUL.2018 18:57:37

### CH39-DH1

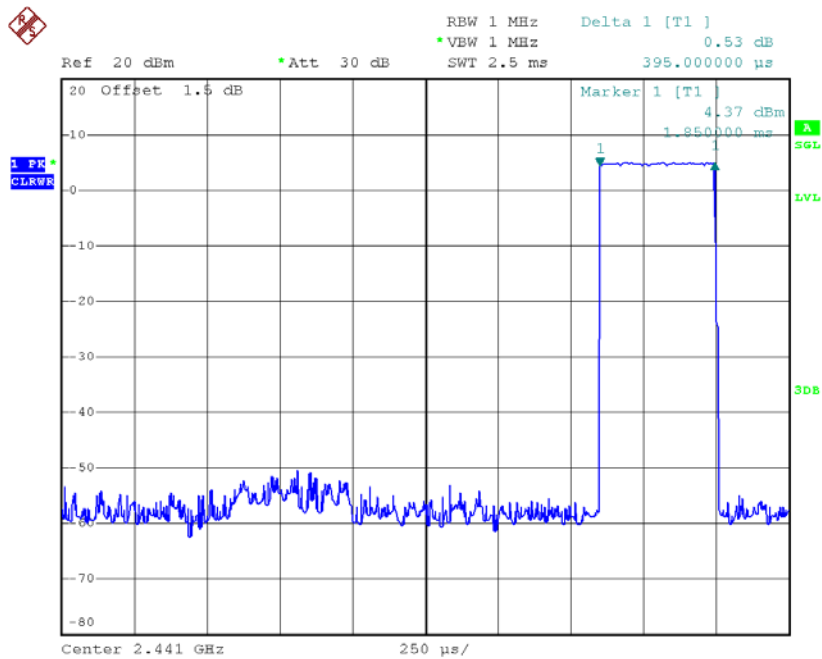

Date: 2.JUL.2018 18:41:25

### CH39-DH3

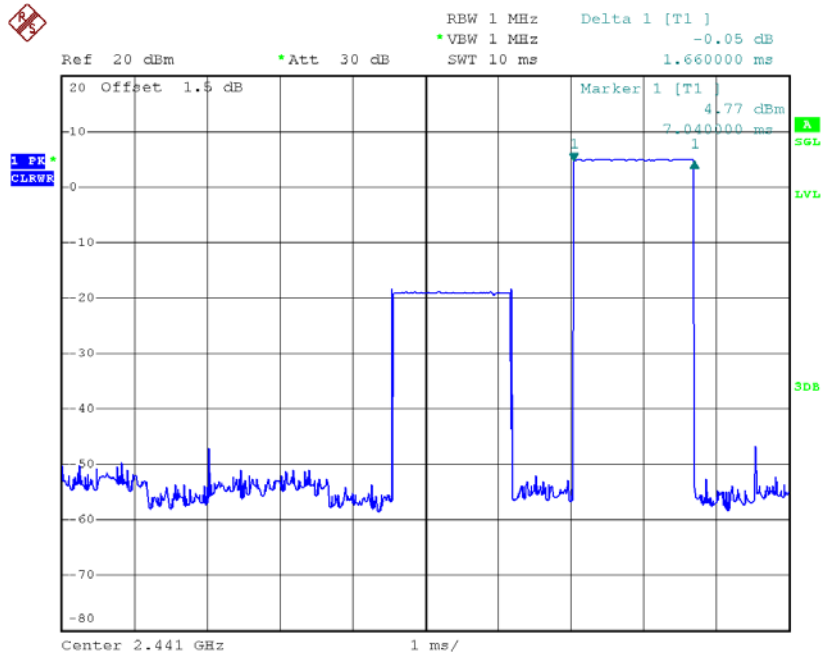

Date: 2.JUL.2018 18:49:13

### CH39-DH5

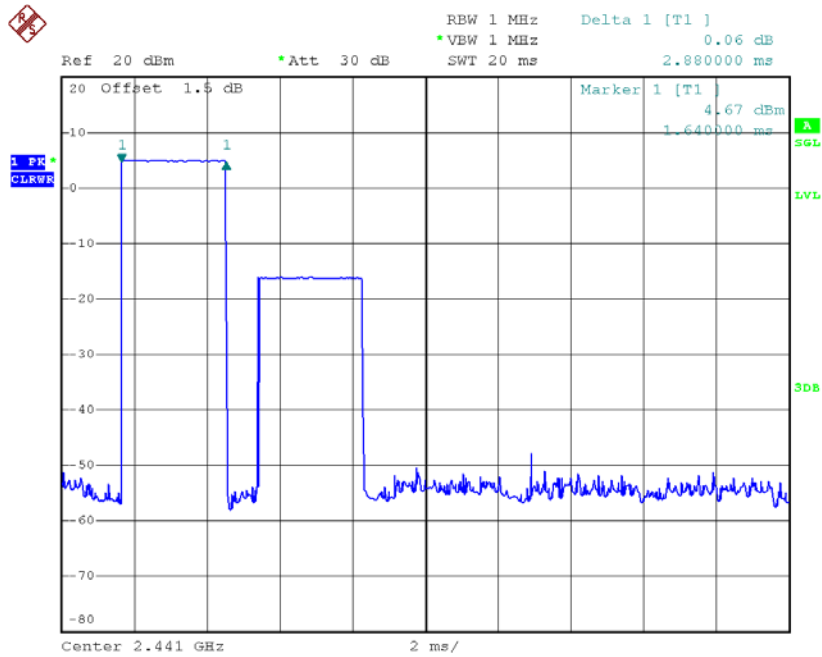

Date: 2.JUL.2018 18:56:43

### CH78-DH1

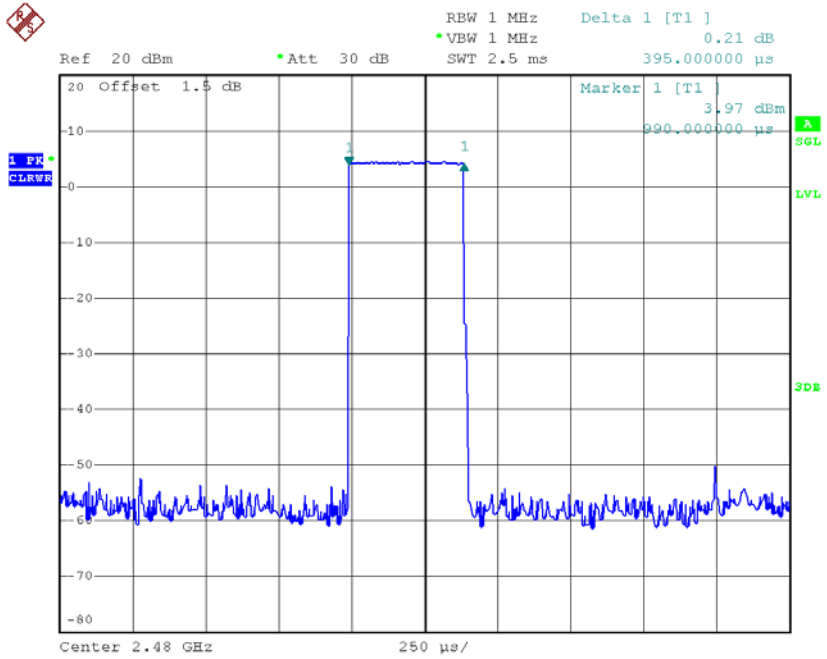

Date: 2.JUL.2018 18:40:45

### CH78-DH3

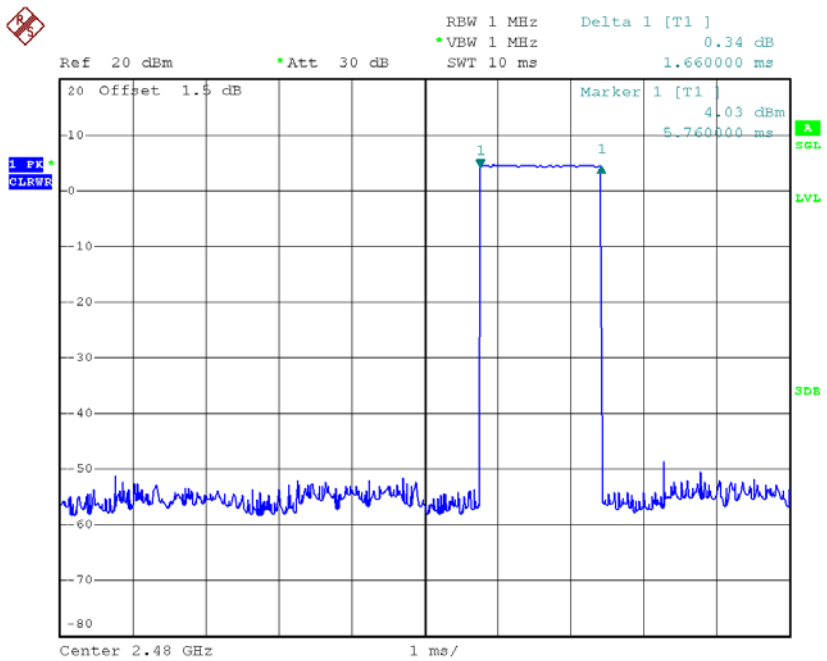

Date: 2.JUL.2018 18:49:19



### CH78-DH5

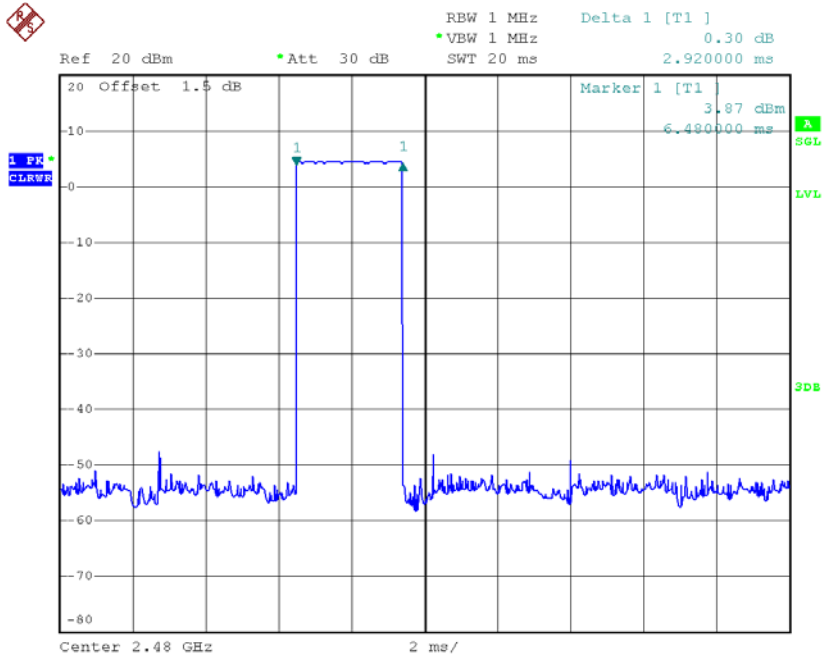

Date: 2.JUL.2018 18:56:47

Test Mode :	TX Mode_3Mbps
-------------	---------------

Data Packet	Frequency	Pulse Duration(ms)	Dwell Time(s)	Limits(s)	Test Result
DH5	2402	2.9200	0.3115	0.4000	Pass
DH3	2402	1.6600	0.2656	0.4000	Pass
DH1	2402	0.4050	0.1296	0.4000	Pass
DH5	2441	2.9200	0.3115	0.4000	Pass
DH3	2441	1.6600	0.2656	0.4000	Pass
DH1	2441	0.4050	0.1296	0.4000	Pass
DH5	2480	2.9200	0.3115	0.4000	Pass
DH3	2480	1.6600	0.2656	0.4000	Pass
DH1	2480	0.4050	0.1296	0.4000	Pass

### CH00-DH1

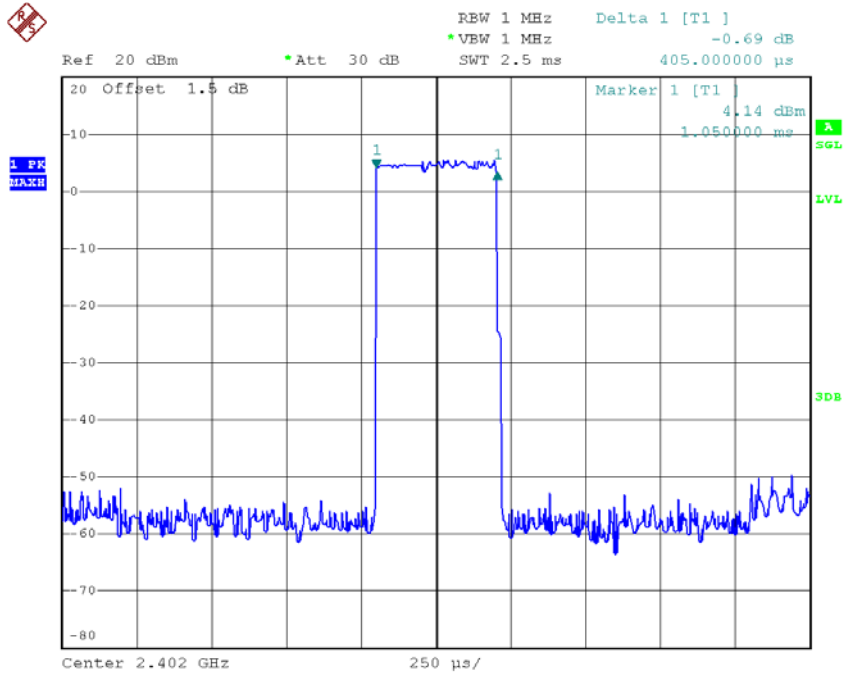

Date: 2.JUL.2018 19:19:53

### CH00-DH3

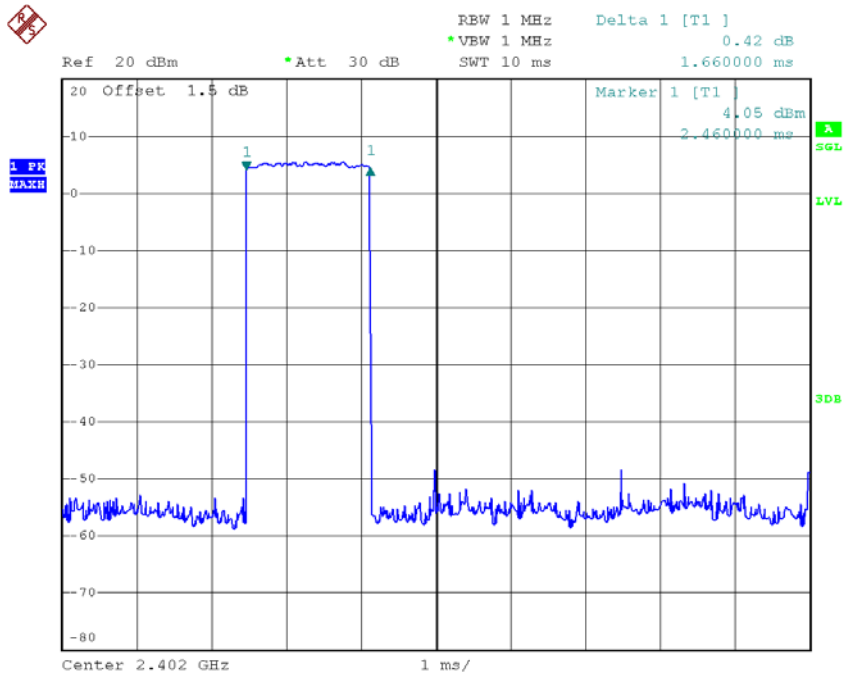

Date: 2.JUL.2018 19:36:04

### CH00-DH5

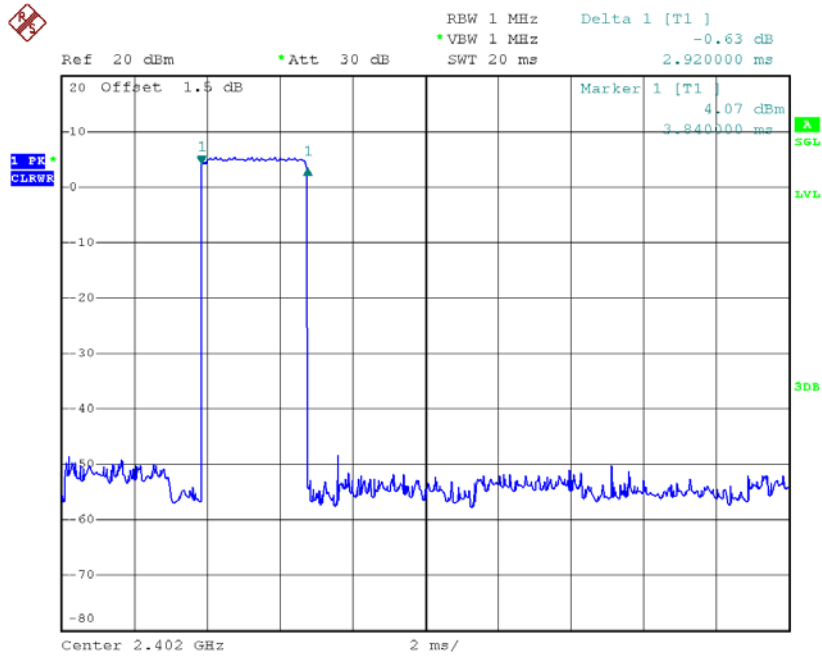

Date: 2.JUL.2018 19:46:46

### CH39-DH1

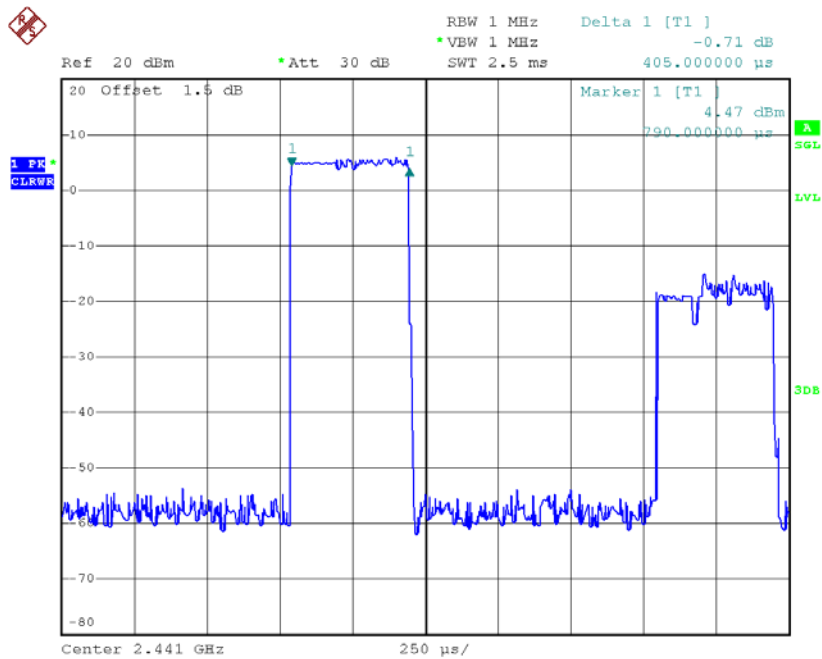

Date: 2.JUL.2018 19:18:50

### CH39-DH3

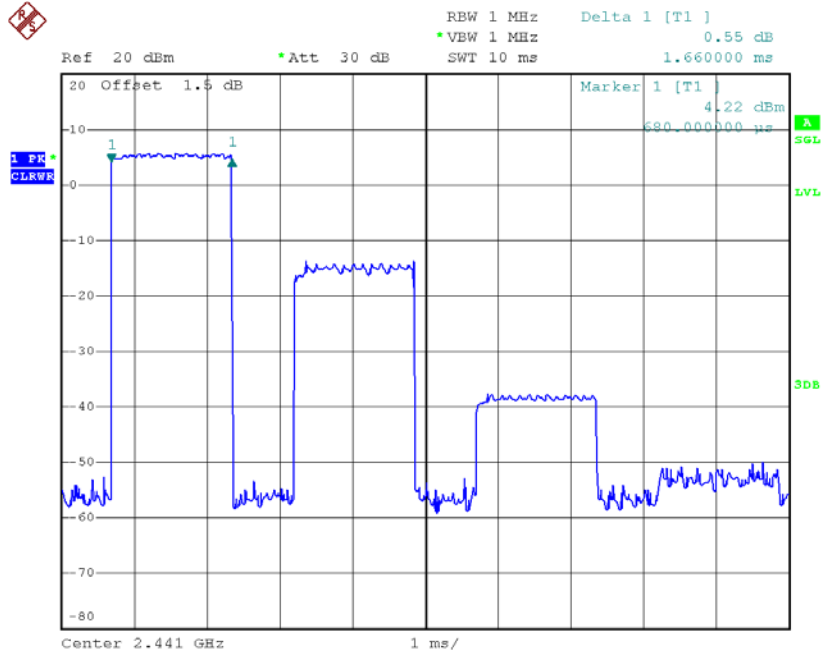

Date: 2.JUL.2018 19:40:10

### CH39-DH5

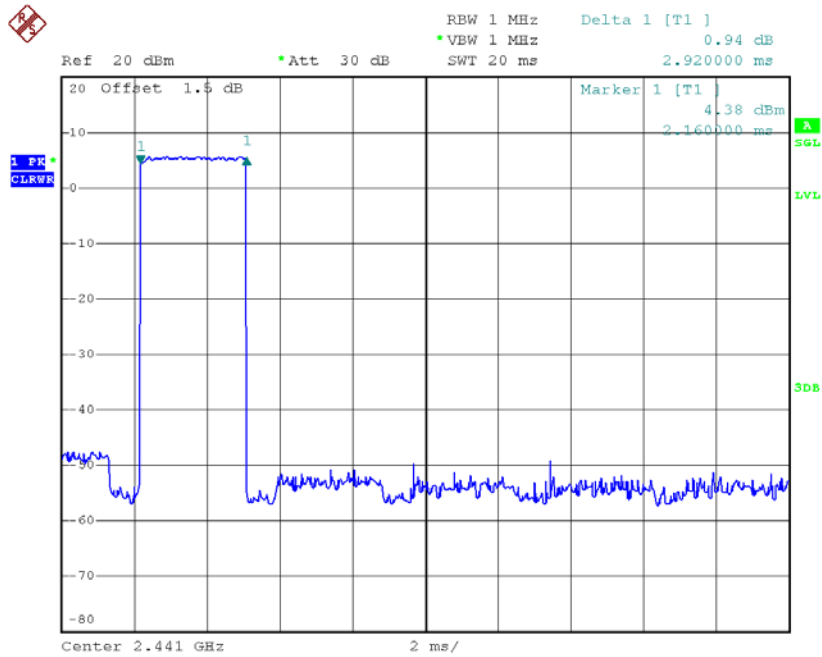

Date: 2.JUL.2018 19:43:46

### CH78-DH1

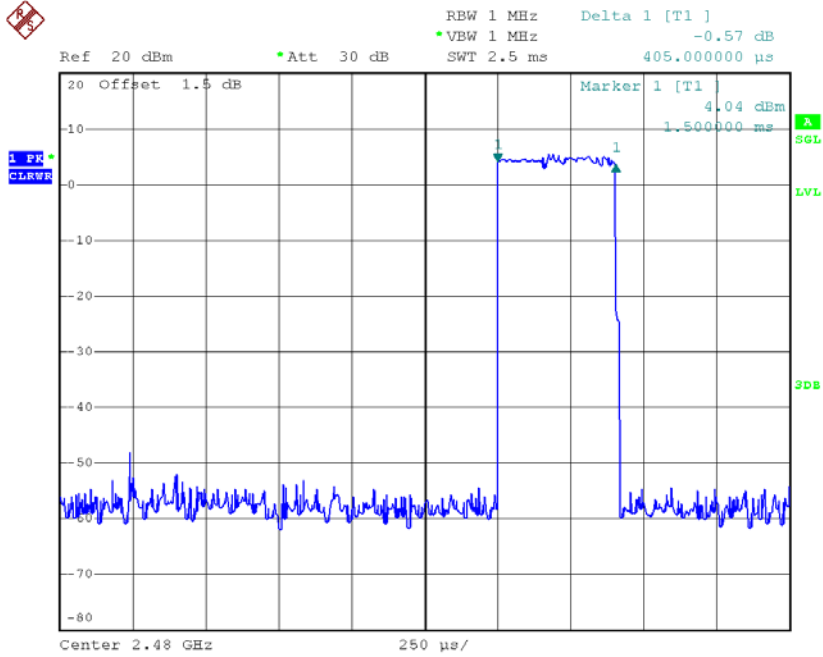

Date: 2.JUL.2018 19:18:57

### CH78-DH3

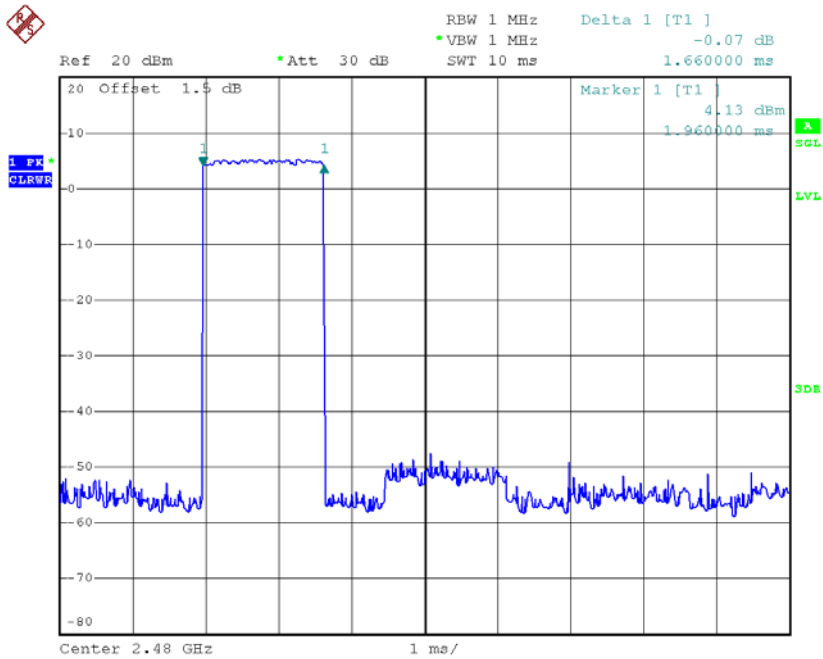

Date: 2.JUL.2018 19:36:22

### CH78-DH5

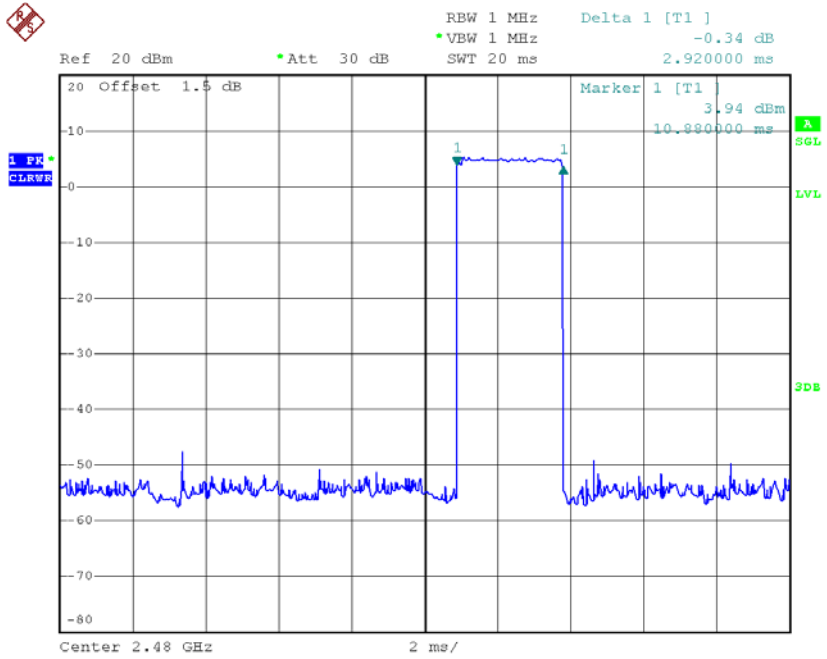

Date: 2.JUL.2018 19:45:38

## APPENDIX G - HOPPING CHANNEL SEPARATION MEASUREMENT



Test Mode : Hopping on \_1Mbps

Frequency (MHz)	Channel Separation (MHz)	2/3 of 20dB Bandwidth (MHz)	Test Result
2402	1.332	0.687	Pass
2441	1.339	0.695	Pass
2480	0.996	0.692	Pass

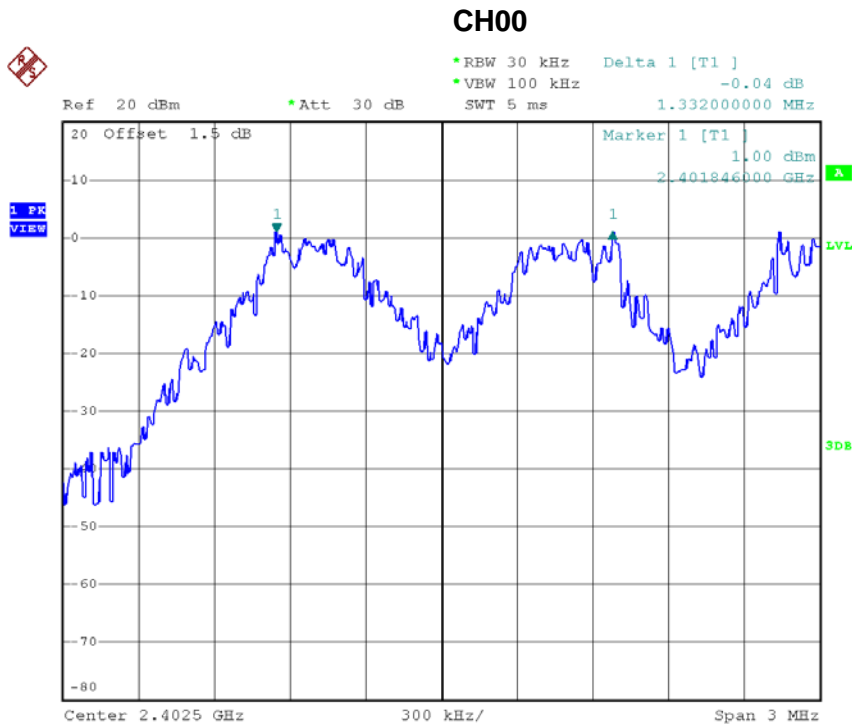

Date: 2.JUL.2018 18:42:30

### CH39

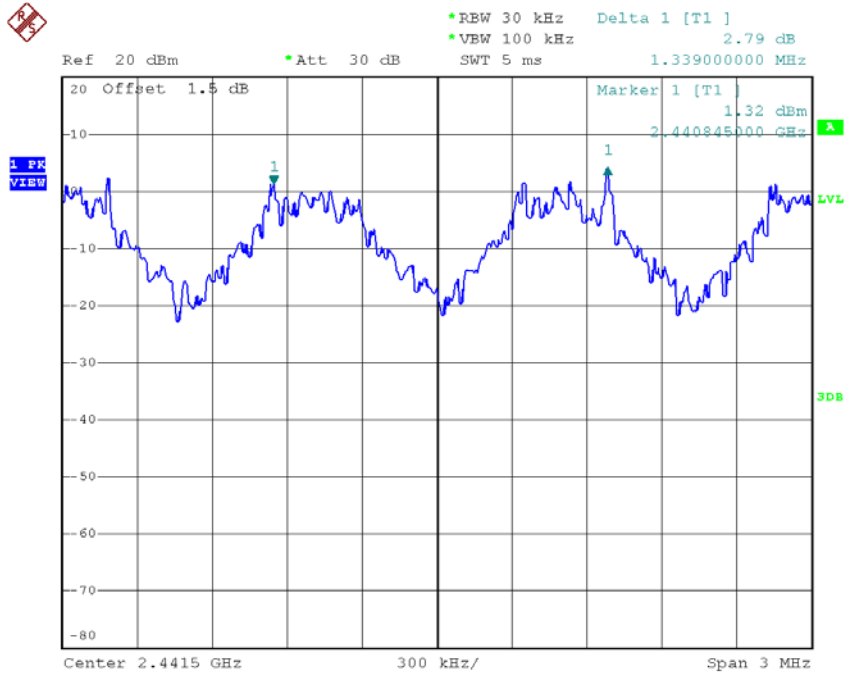

Date: 2.JUL.2018 18:43:38

### CH78

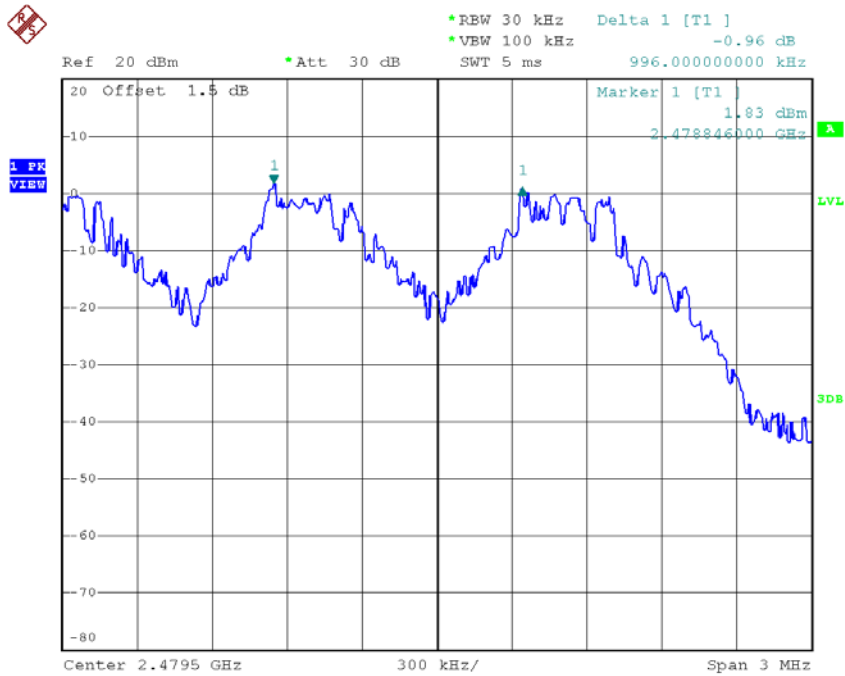

Date: 2.JUL.2018 18:44:42

Test Mode : Hopping on \_3Mbps

Frequency (MHz)	Channel Separation (MHz)	2/3 of 20dB Bandwidth (MHz)	Test Result
2402	1.019	0.865	Pass
2441	0.990	0.868	Pass
2480	1.344	0.863	Pass

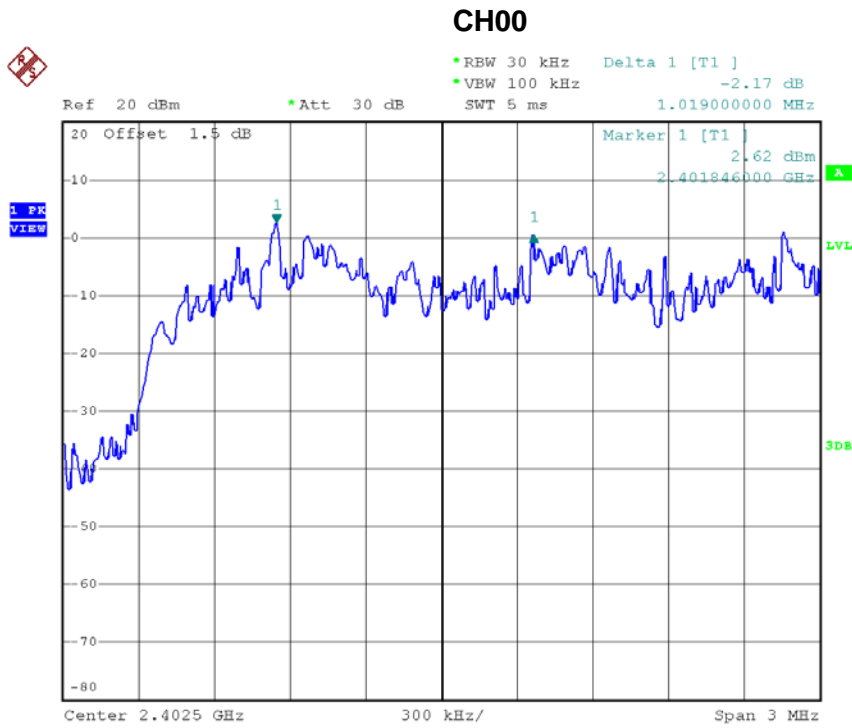

Date: 2.JUL.2018 19:21:02

### CH39

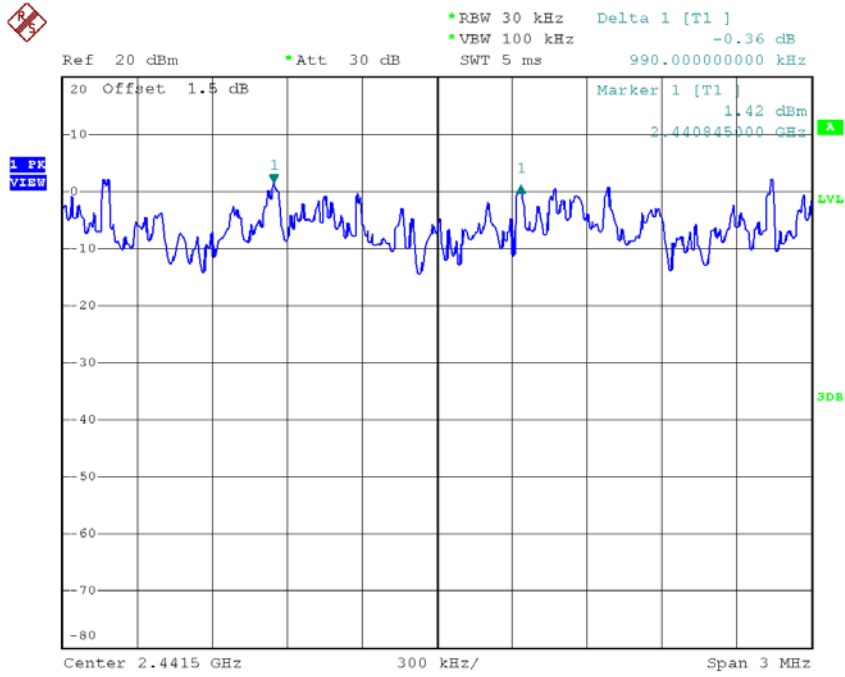

Date: 2.JUL.2018 19:31:19

### CH78

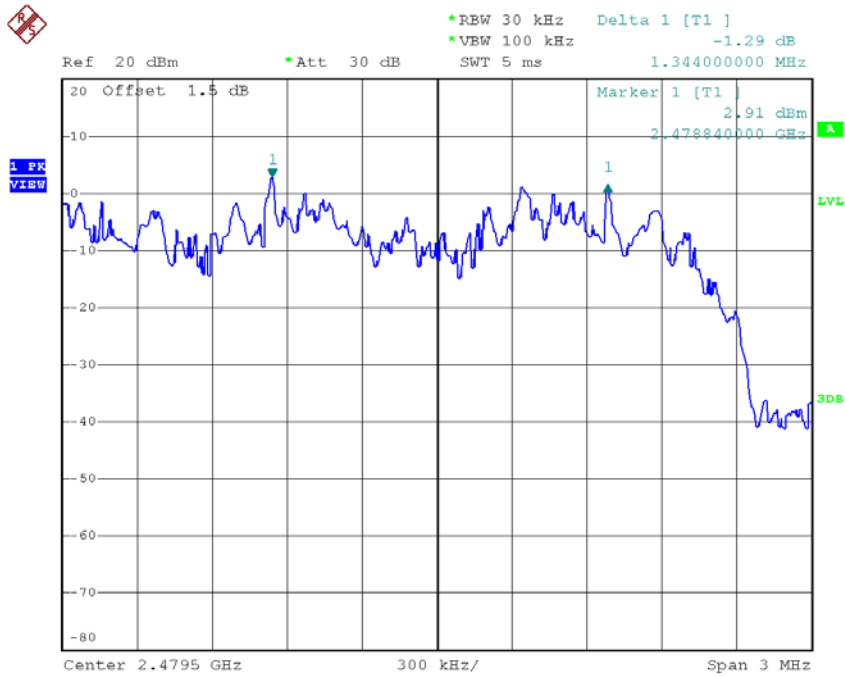

Date: 2.JUL.2018 19:23:16

## APPENDIX H - BANDWIDTH

Test Mode : TX Mode \_1Mbps

Frequency (MHz)	20dB Bandwidth (MHz)	99% Occupied BW (MHz)	Test Result
2402	1.031	0.920	Pass
2441	1.042	0.924	Pass
2480	1.038	0.912	Pass

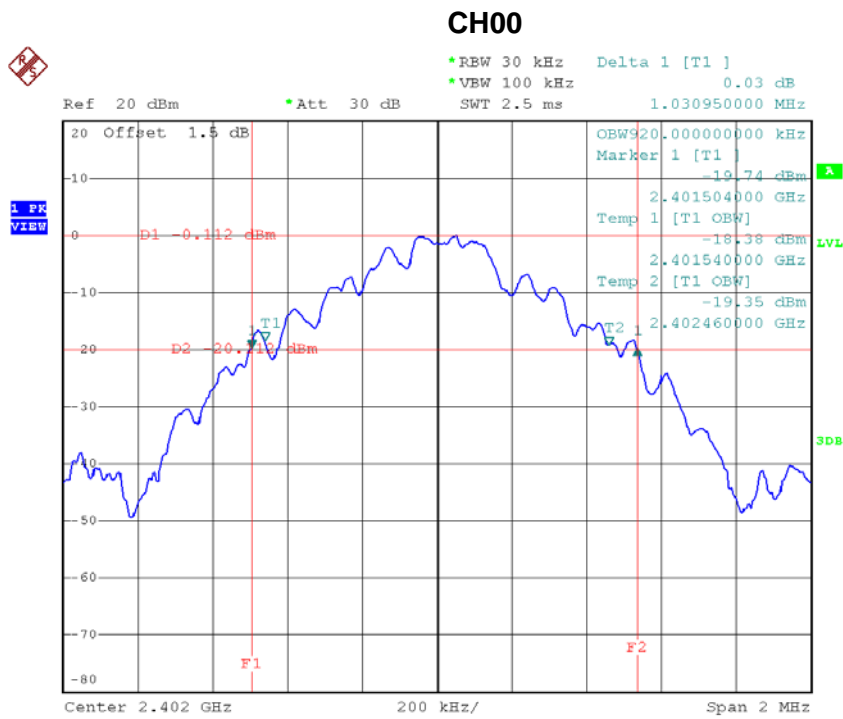

Date: 2.JUL.2018 17:55:27

**CH39**

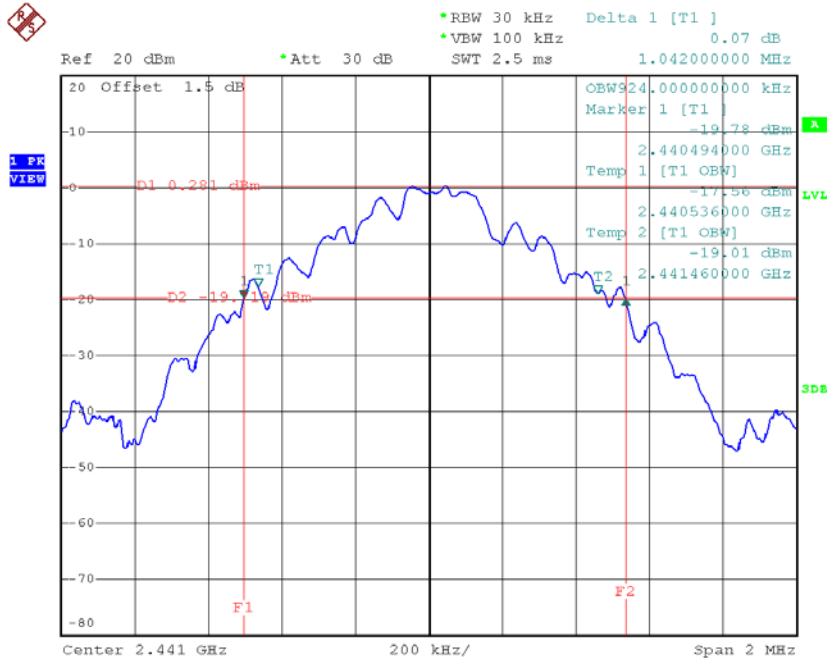

Date: 2.JUL.2018 17:58:09

**CH78**

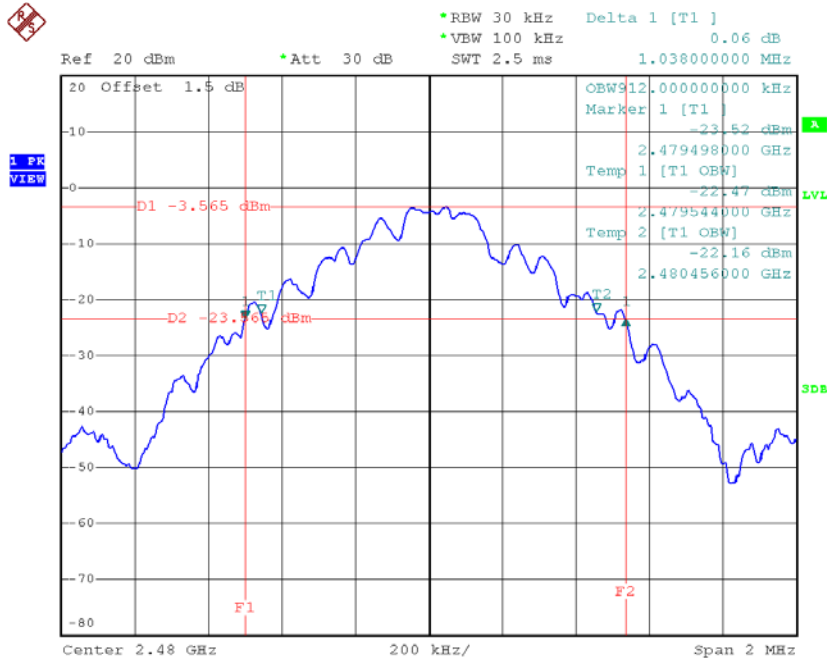

Date: 2.JUL.2018 18:00:48

Test Mode : TX Mode \_3Mbps

Frequency (MHz)	20dB Bandwidth (MHz)	99% Occupied BW (MHz)	Test Result
2402	1.297	1.180	Pass
2441	1.302	1.180	Pass
2480	1.294	1.172	Pass

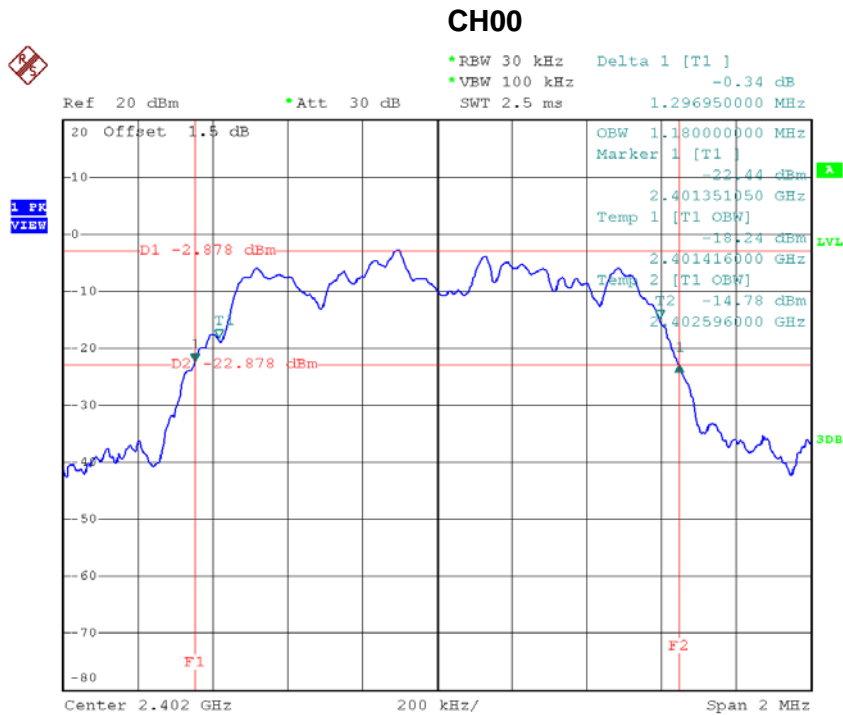

Date: 2.JUL.2018 19:02:16



**CH39**

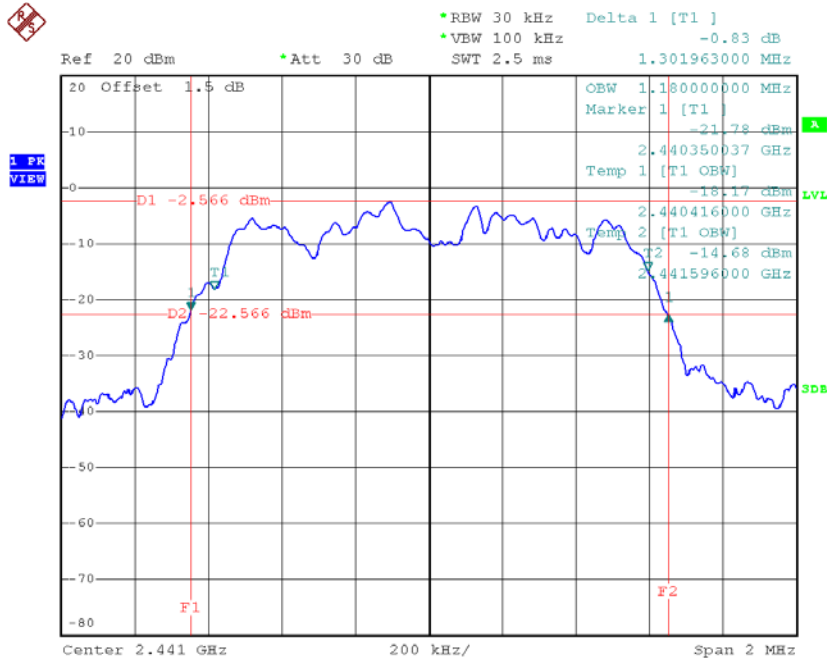

Date: 2.JUL.2018 19:06:47

**CH78**

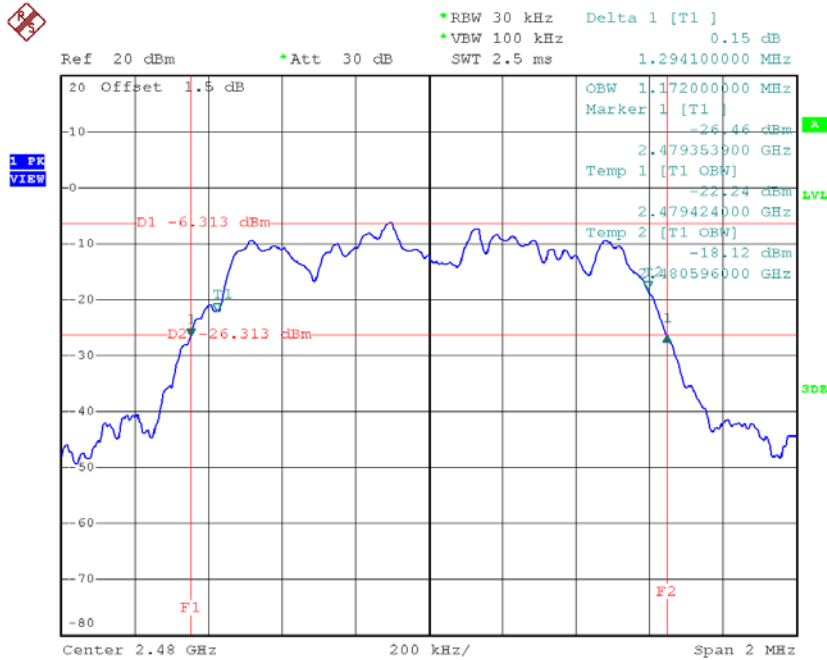

Date: 2.JUL.2018 19:12:08

## APPENDIX I - PEAK OUTPUT POWER

Test Mode : TX Mode \_1Mbps

Frequency (MHz)	Conducted Power (dBm)	Conducted Power (W)	Max. Limit (dBm)	Max. Limit (W)	Test Result
2402	4.55	0.0029	21.00	0.125	Pass
2441	4.83	0.0030	21.00	0.125	Pass
2480	1.16	0.0013	21.00	0.125	Pass

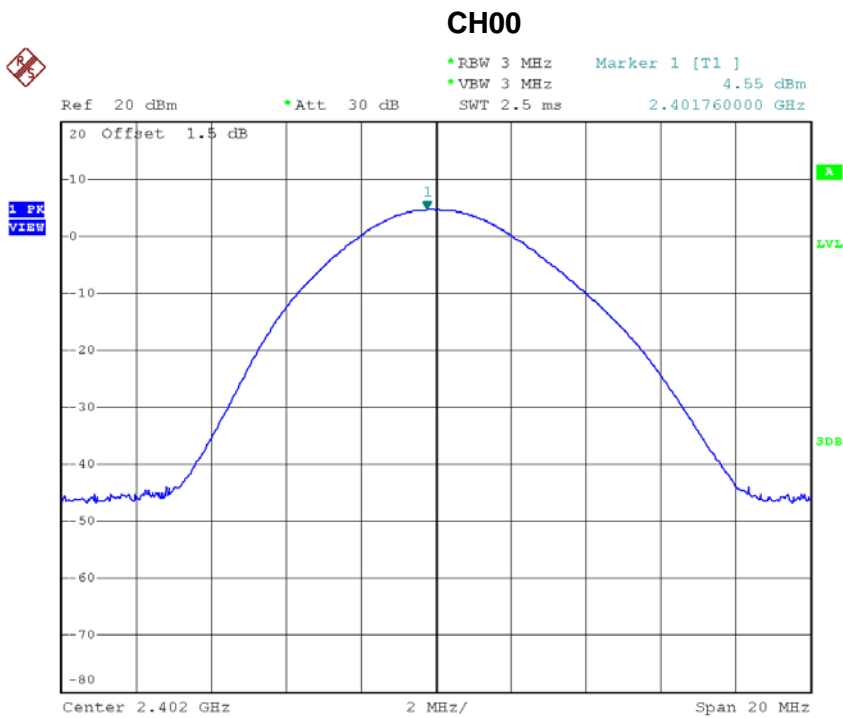

Date: 2.JUL.2018 18:33:54

### CH39

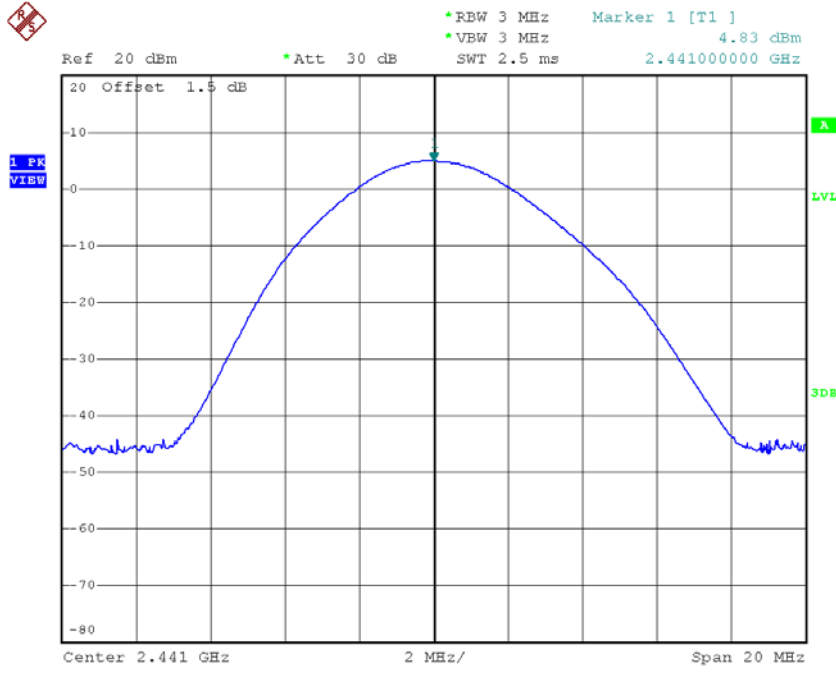

Date: 2.JUL.2018 17:58:16

### CH78

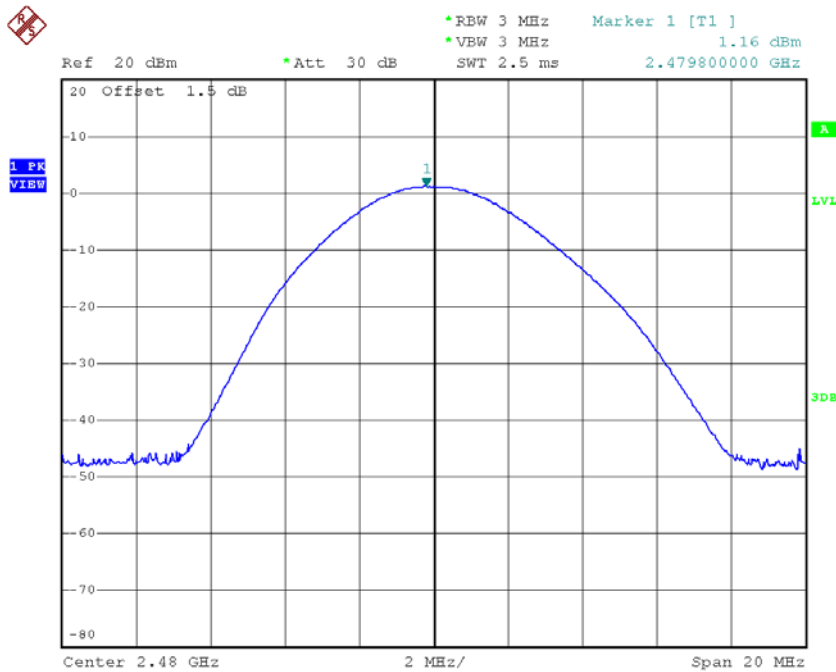

Date: 2.JUL.2018 18:01:25

Test Mode : TX Mode \_3Mbps

Frequency (MHz)	Conducted Power (dBm)	Conducted Power (W)	Max. Limit (dBm)	Max. Limit (W)	Test Result
2402	6.13	0.0041	21.00	0.125	Pass
2441	6.49	0.0045	21.00	0.125	Pass
2480	2.90	0.0019	21.00	0.125	Pass

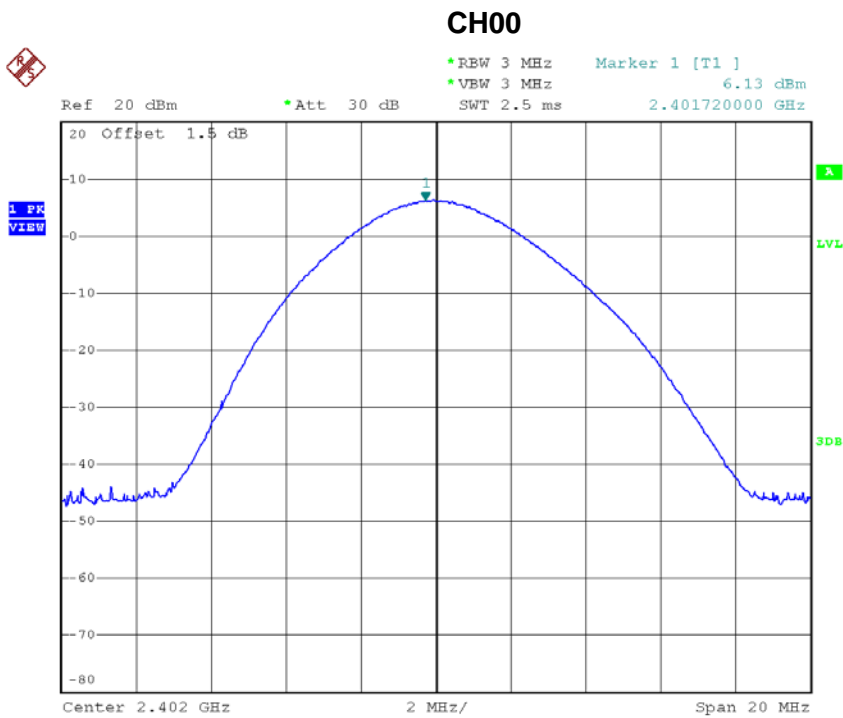

Date: 2.JUL.2018 19:01:47

### CH39

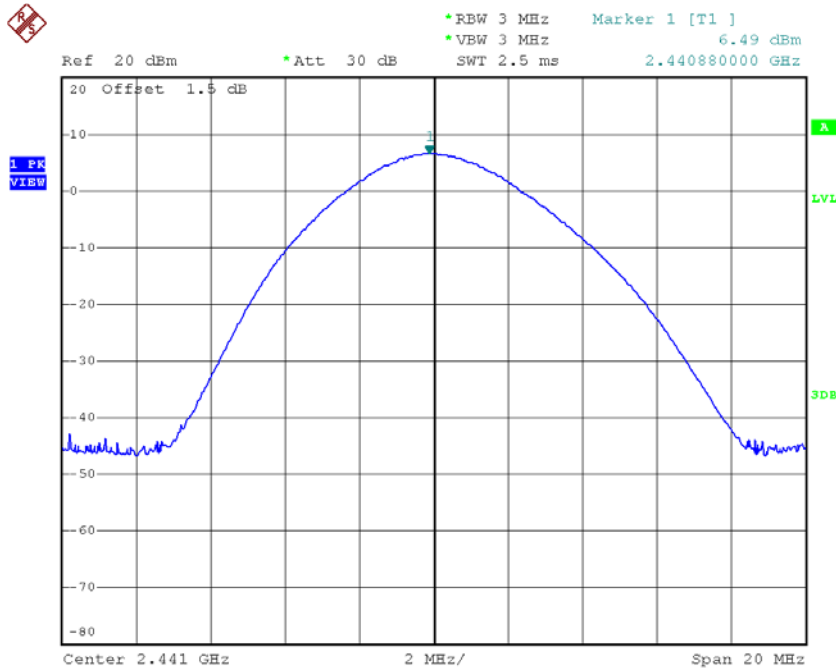

Date: 2.JUL.2018 19:05:47

### CH78

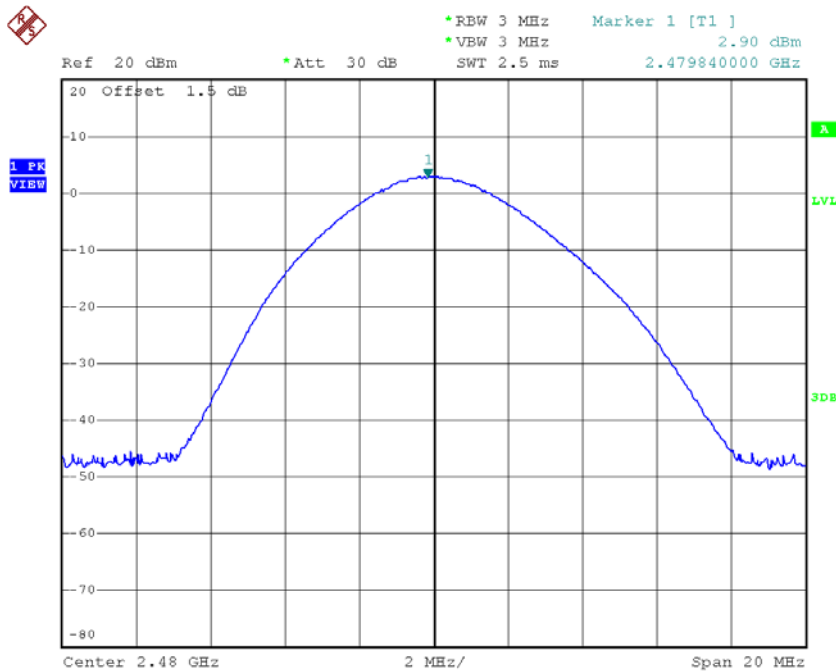

Date: 2.JUL.2018 19:12:46

## APPENDIX J - ANTENNA CONDUCTED SPURIOUS EMISSION

### CH00 (Lower)\_1Mbps

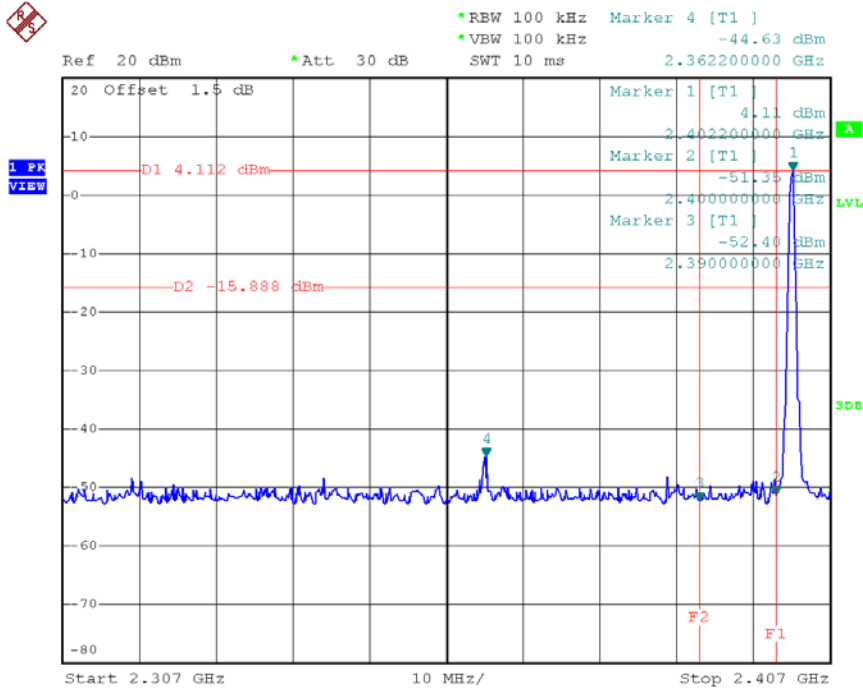

Date: 2.JUL.2018 17:55:01

### CH78 (Upper)\_1Mbps

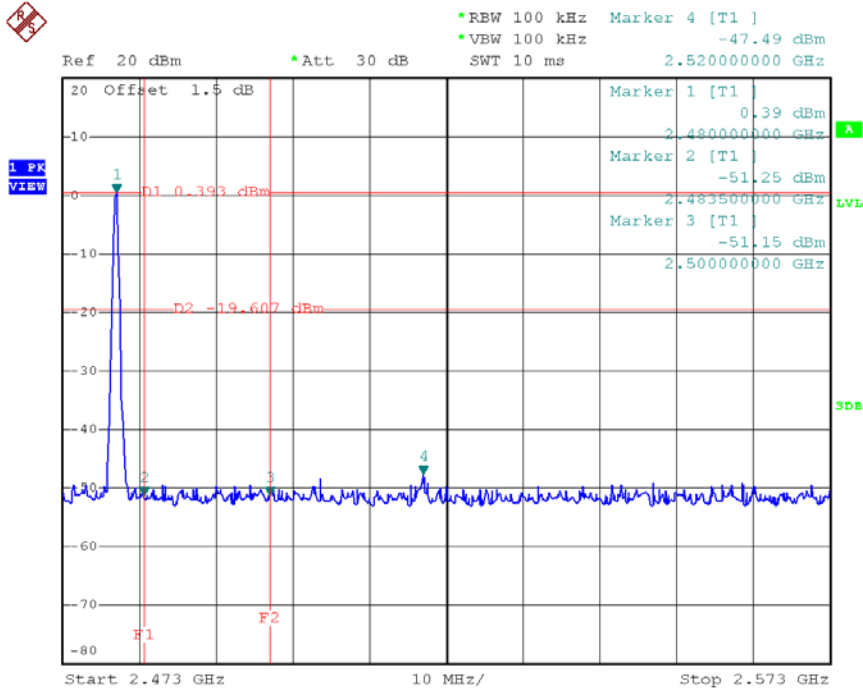

Date: 2.JUL.2018 18:00:22



### CH00 Hopping on mode (Lower)\_1Mbps

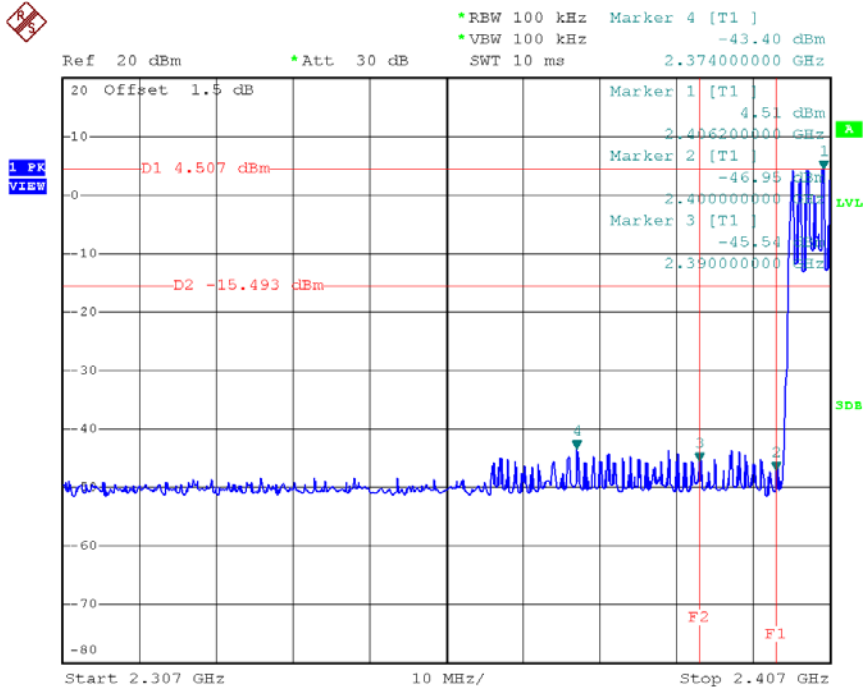

Date: 2.JUL.2018 18:47:07

### CH78 Hopping on mode (Upper)\_1Mbps

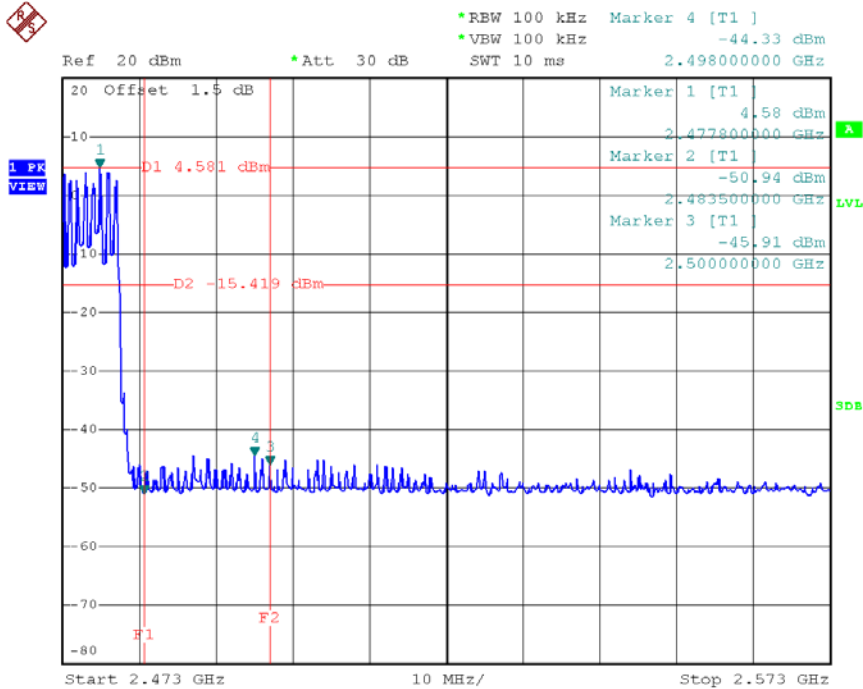

Date: 2.JUL.2018 18:47:42

### CH00 (10 Harmonic of the frequency) \_1Mbps

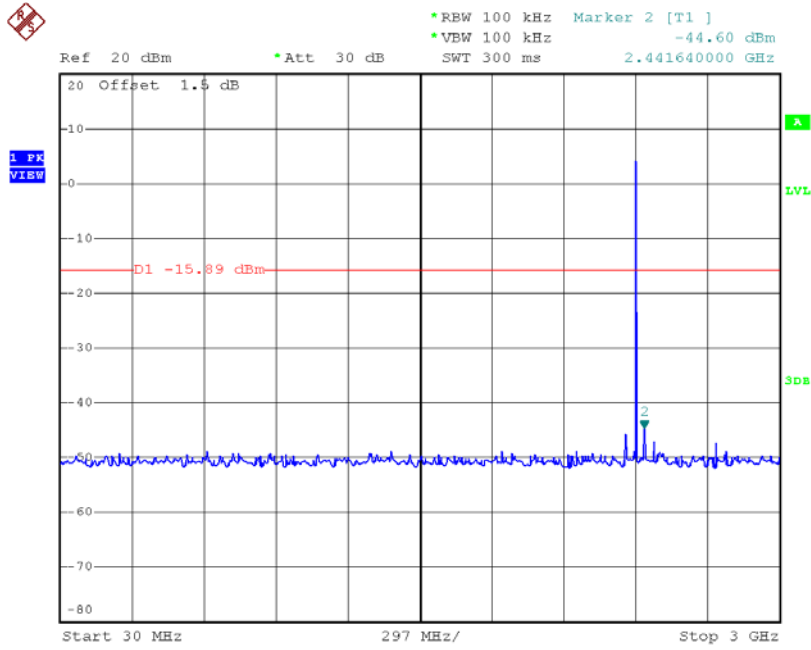

Date: 2.JUL.2018 17:55:41

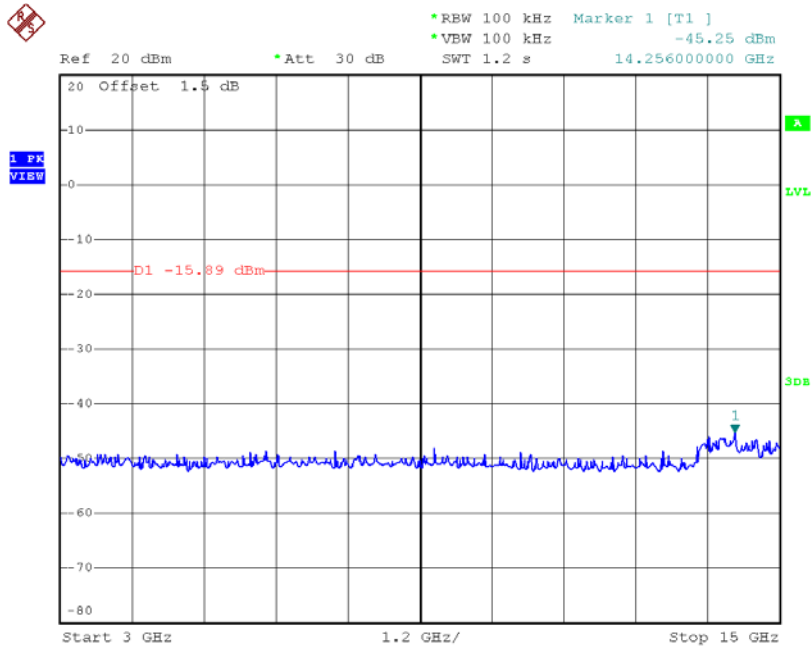

Date: 2.JUL.2018 17:55:50

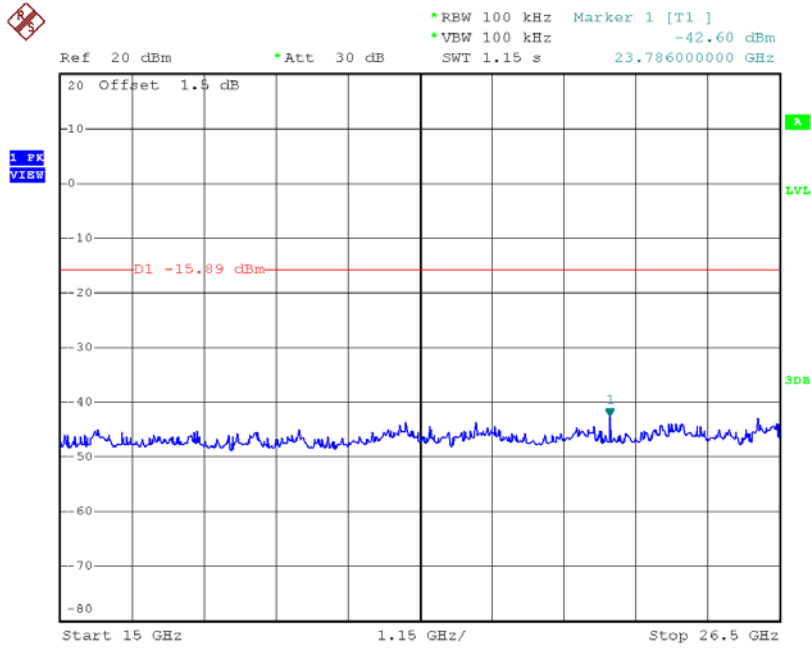

Date: 2.JUL.2018 17:55:59

### CH39 (10 Harmonic of the frequency) \_1Mbps

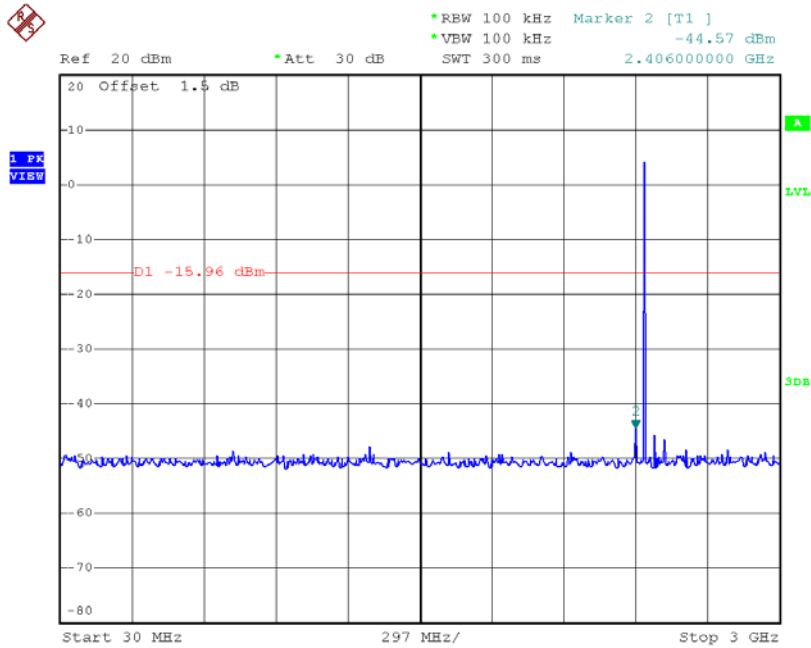

Date: 2.JUL.2018 17:57:27

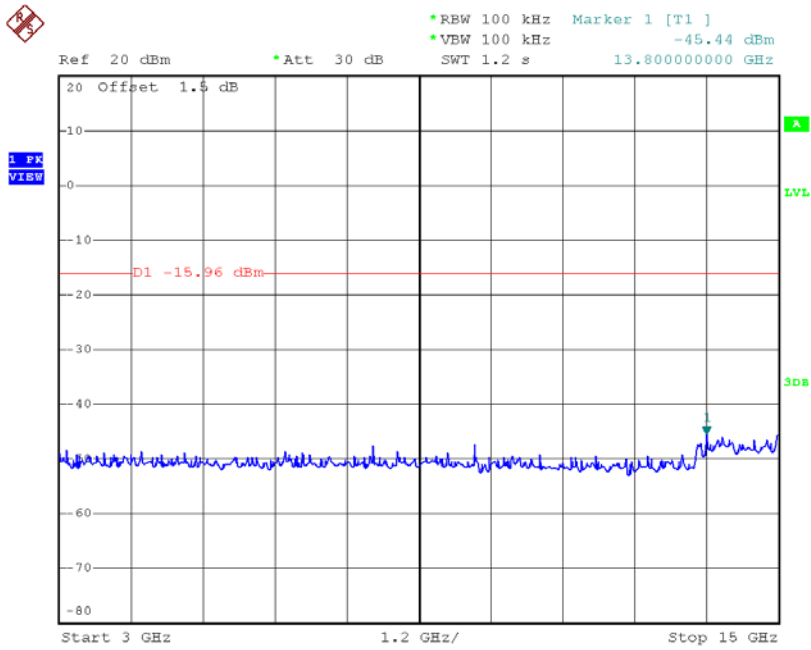

Date: 2.JUL.2018 17:57:36

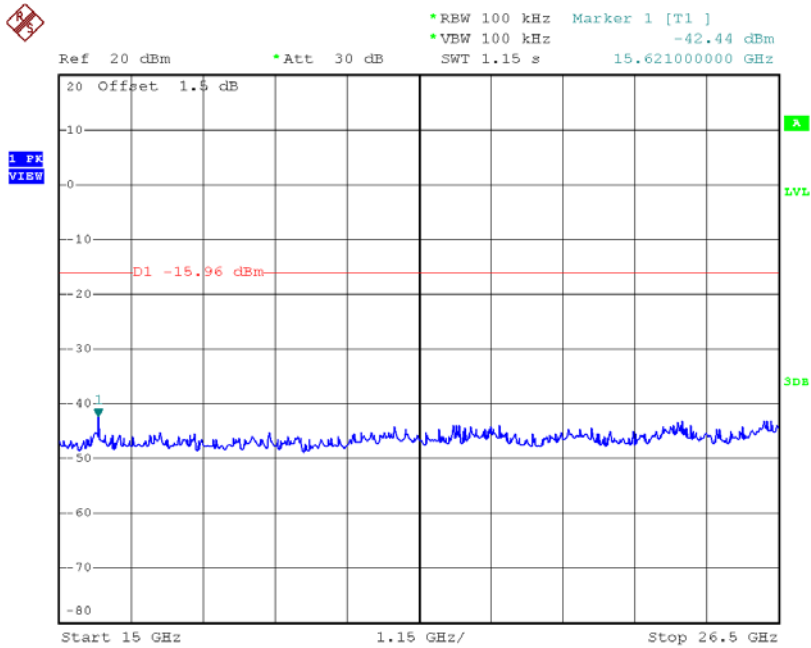

Date: 2.JUL.2018 17:57:44

### CH78 (10 Harmonic of the frequency) \_1Mbps

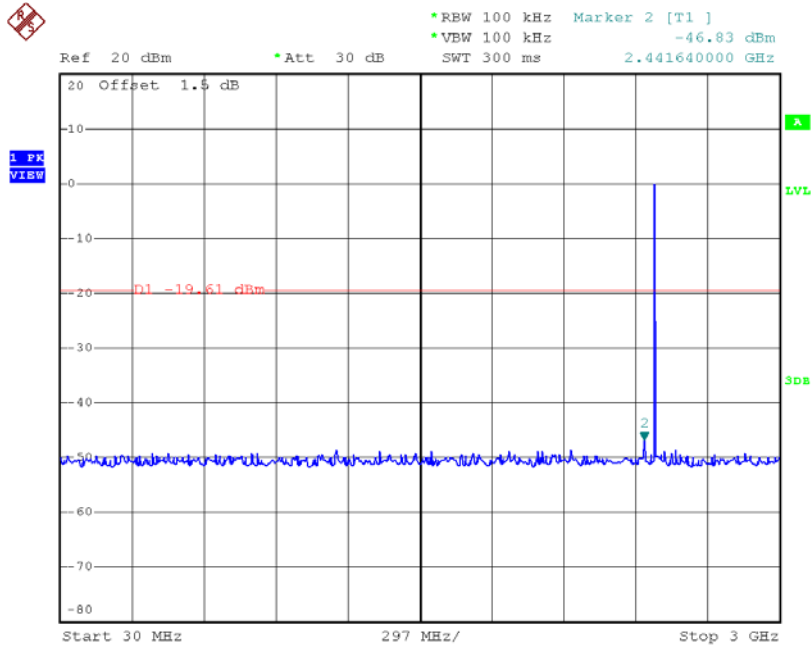

Date: 2.JUL.2018 18:01:02

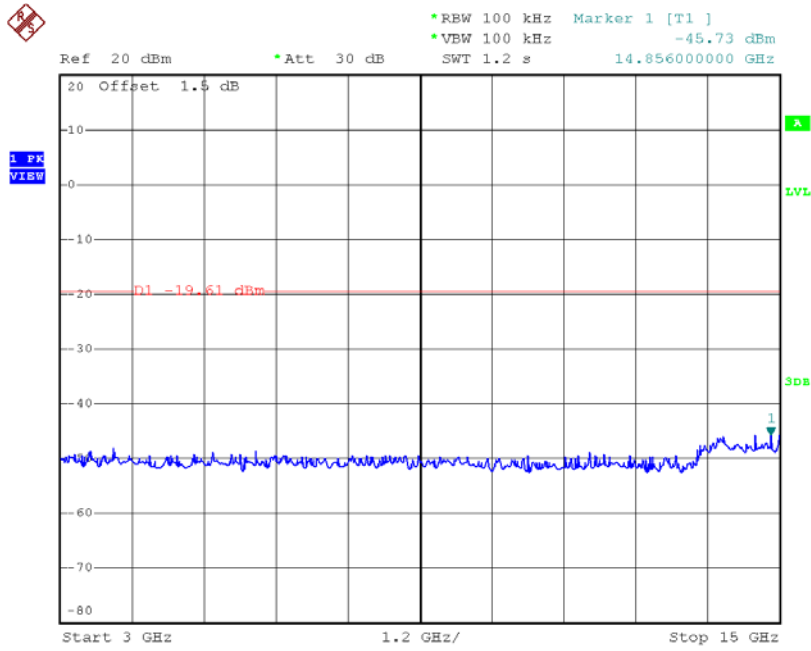

Date: 2.JUL.2018 18:01:10

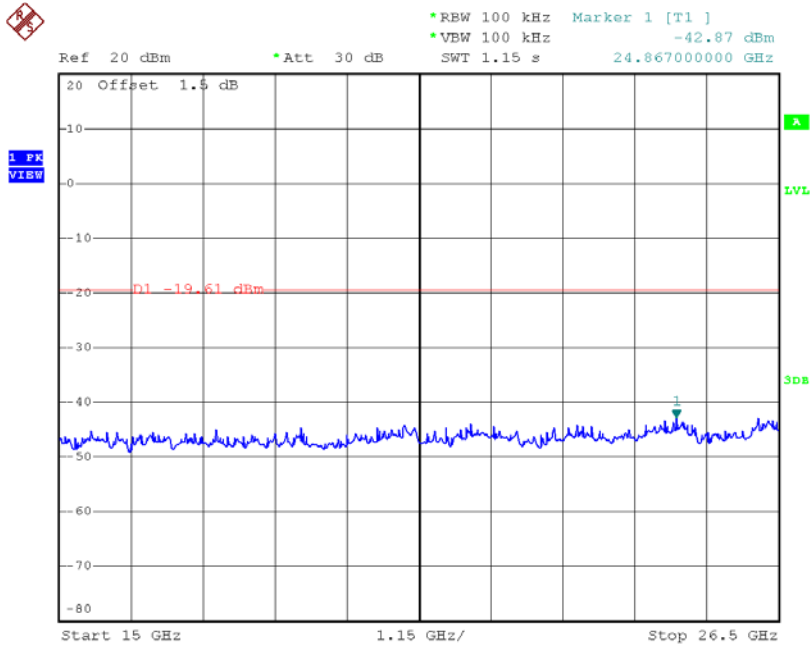

Date: 2.JUL.2018 18:01:19

### CH00 (Lower) \_3Mbps

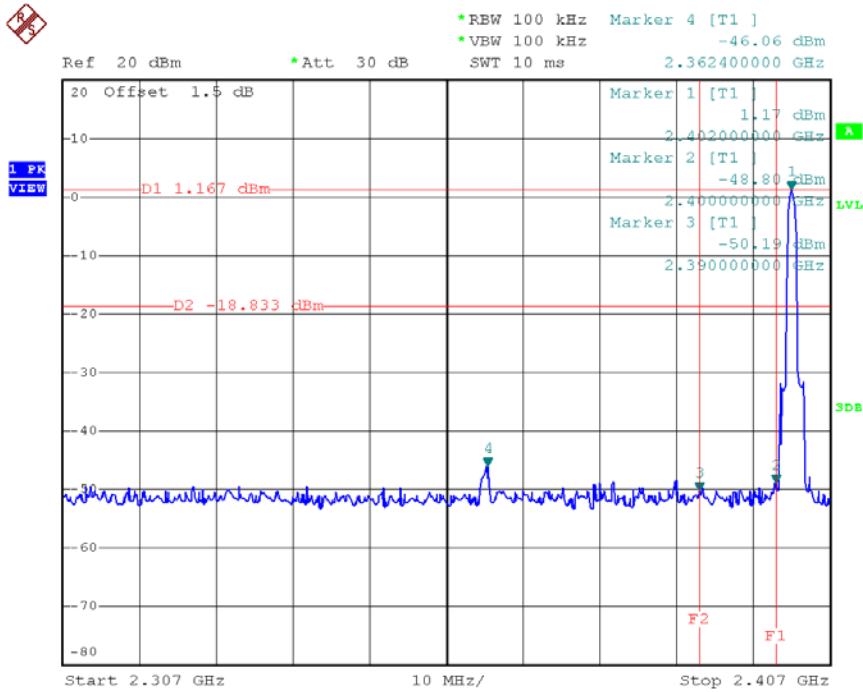

Date: 2.JUL.2018 19:01:56

### CH78 (Upper) \_3Mbps

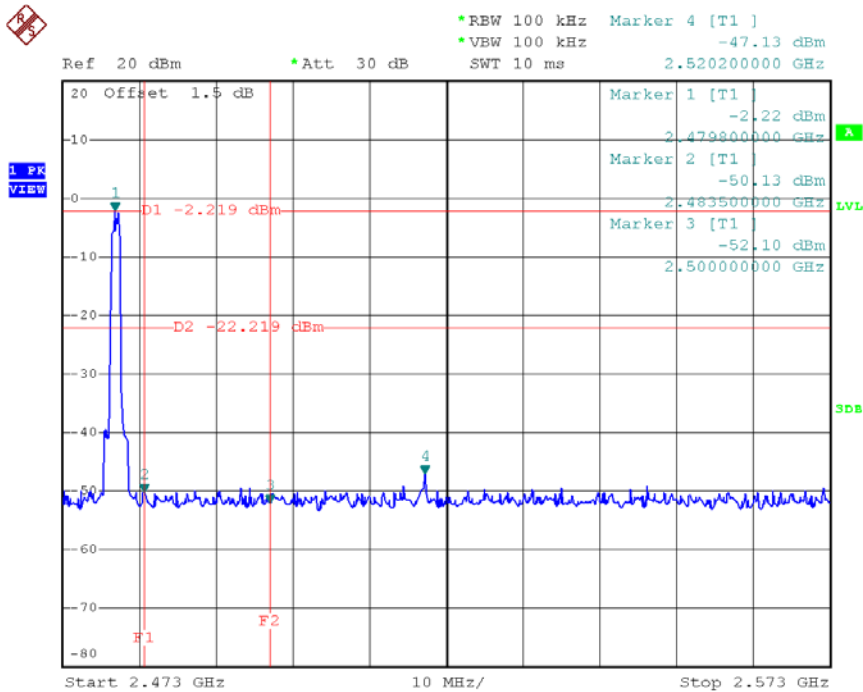

Date: 2.JUL.2018 19:11:47

### CH00 Hopping on mode (Lower)\_3Mbps

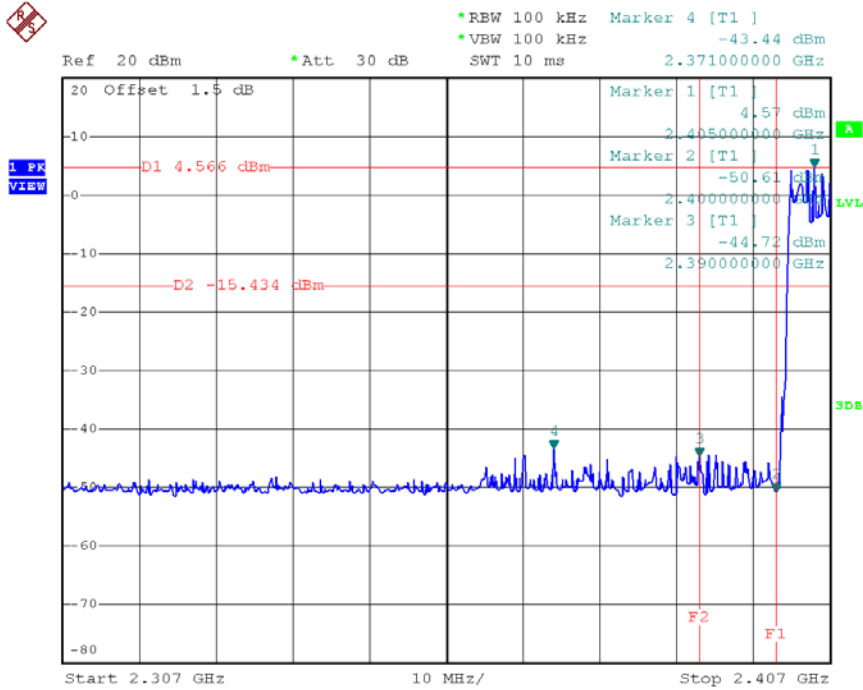

Date: 2.JUL.2018 19:31:55

### CH78 Hopping on mode (Upper)\_3Mbps

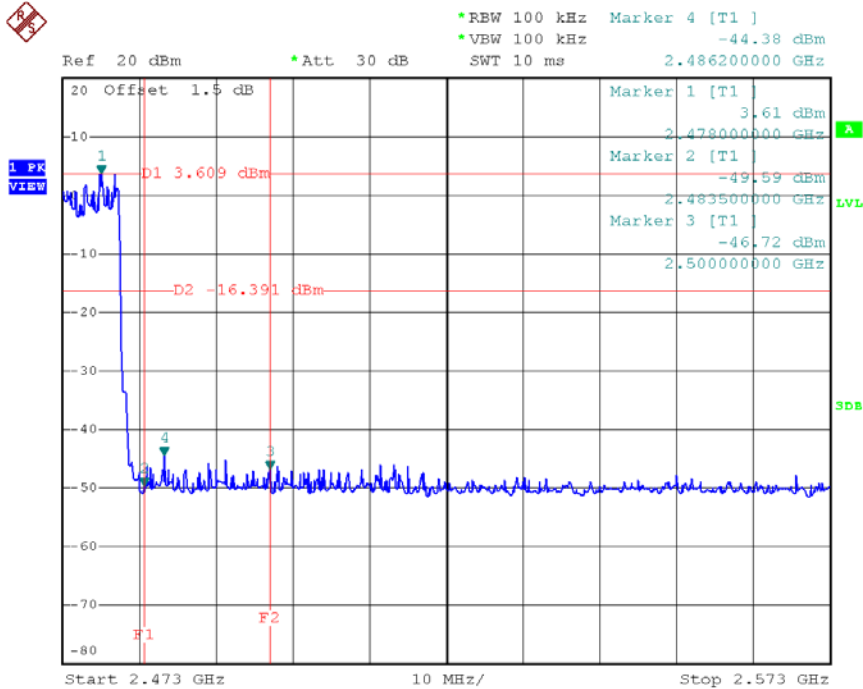

Date: 2.JUL.2018 19:26:15



### CH00 (10 Harmonic of the frequency) \_3Mbps

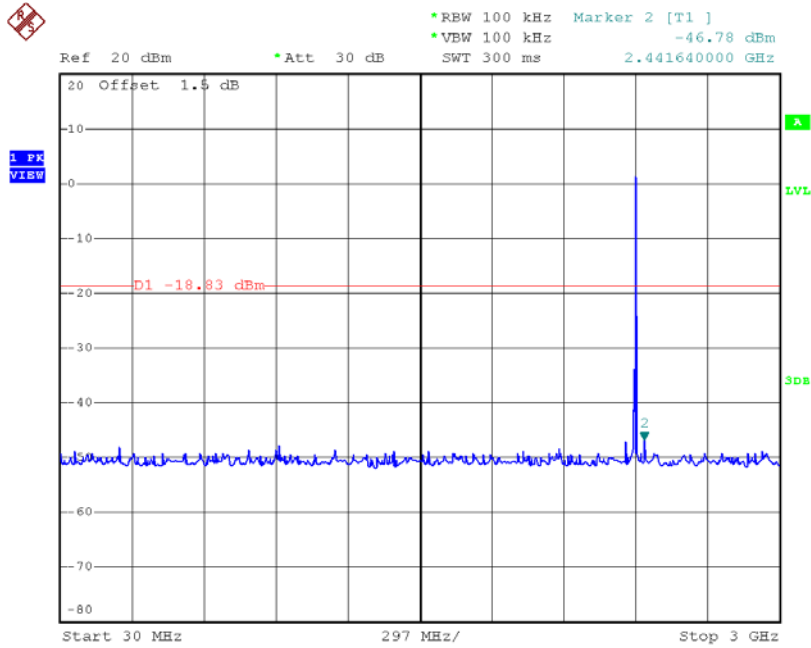

Date: 2.JUL.2018 19:02:30

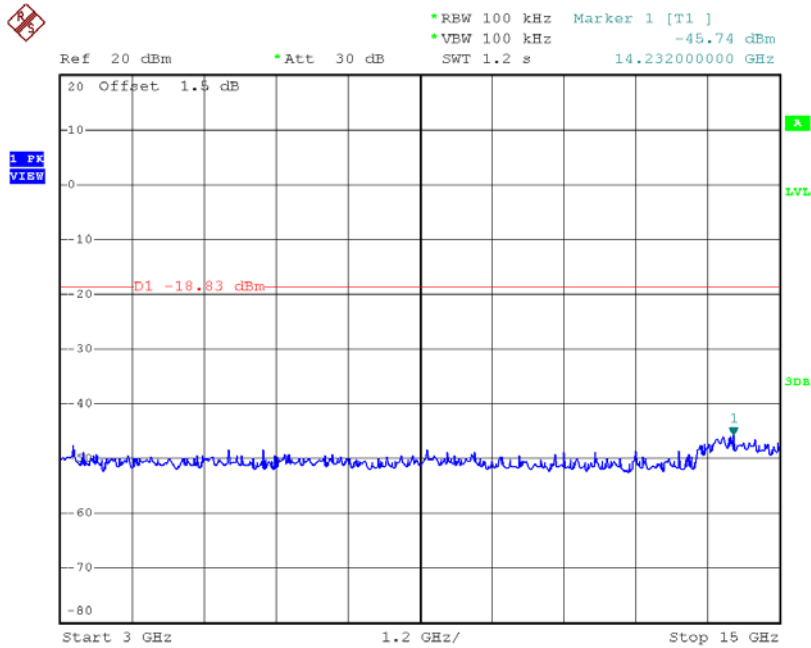

Date: 2.JUL.2018 19:02:39

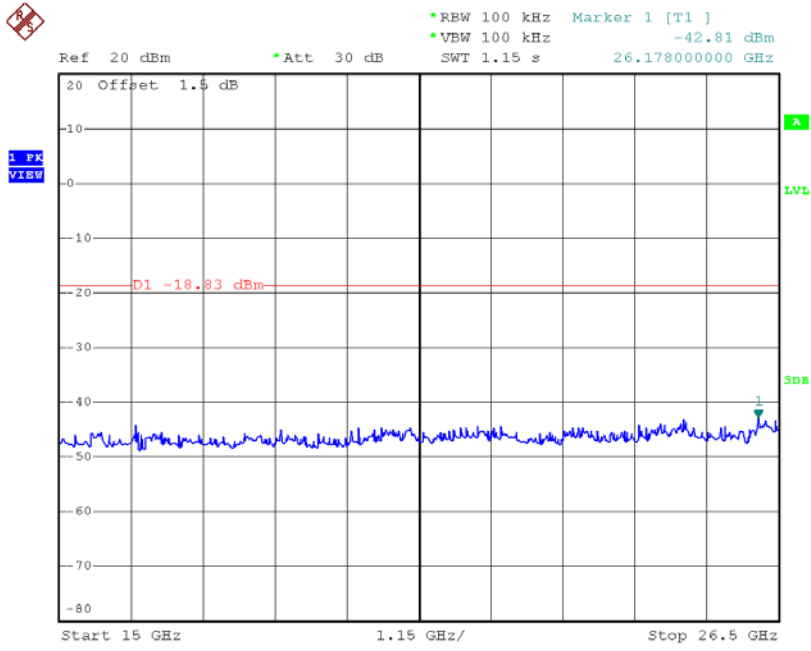

Date: 2.JUL.2018 19:02:48

### CH39 (10 Harmonic of the frequency) \_3Mbps

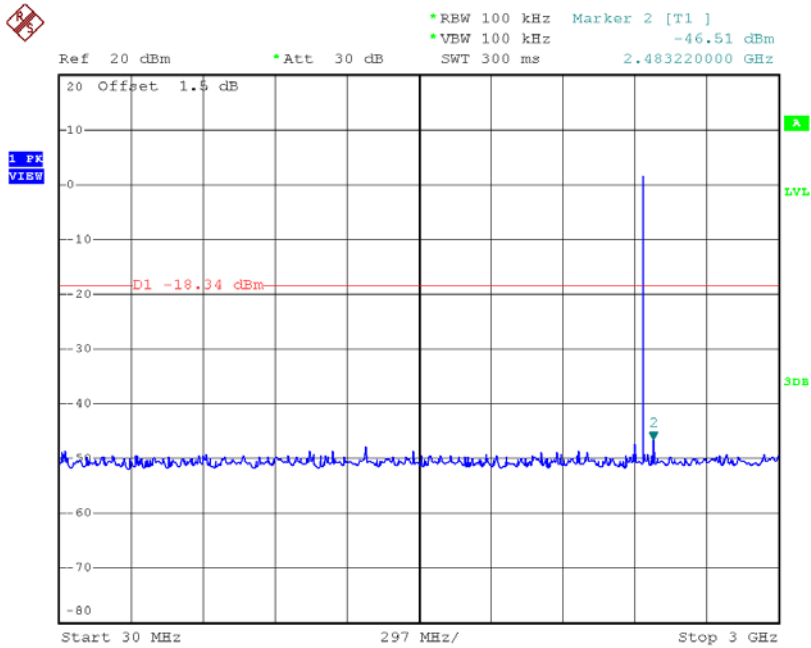

Date: 2.JUL.2018 19:06:09

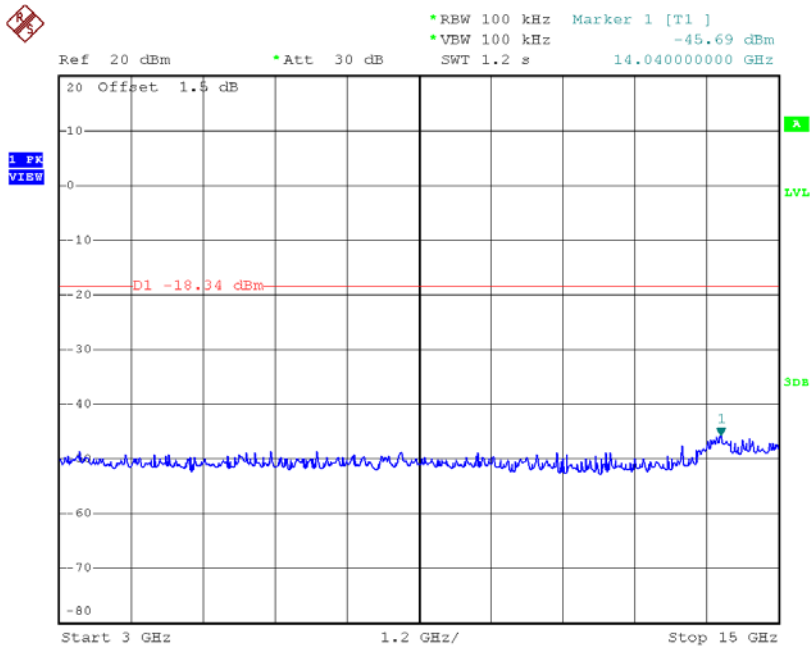

Date: 2.JUL.2018 19:06:18

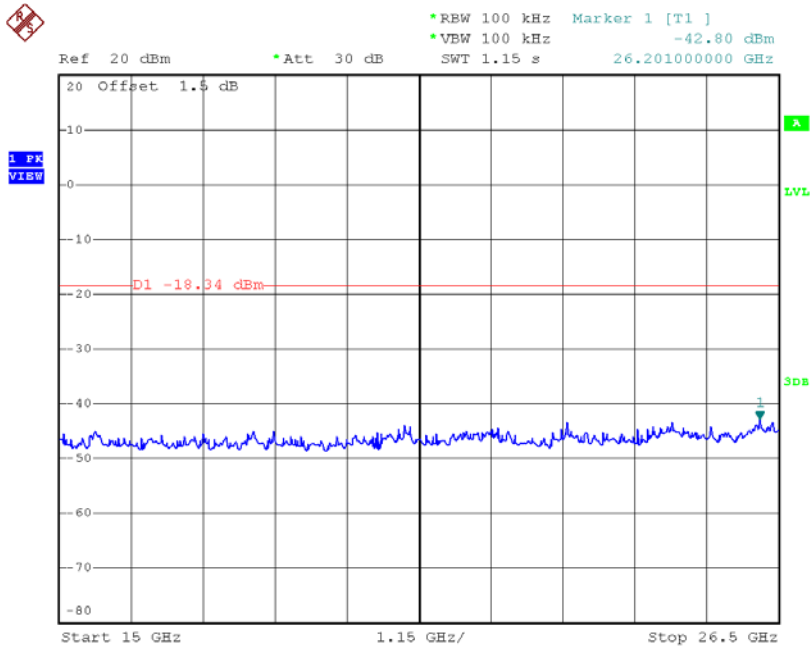

Date: 2.JUL.2018 19:06:26

### CH78 (10 Harmonic of the frequency) \_3Mbps

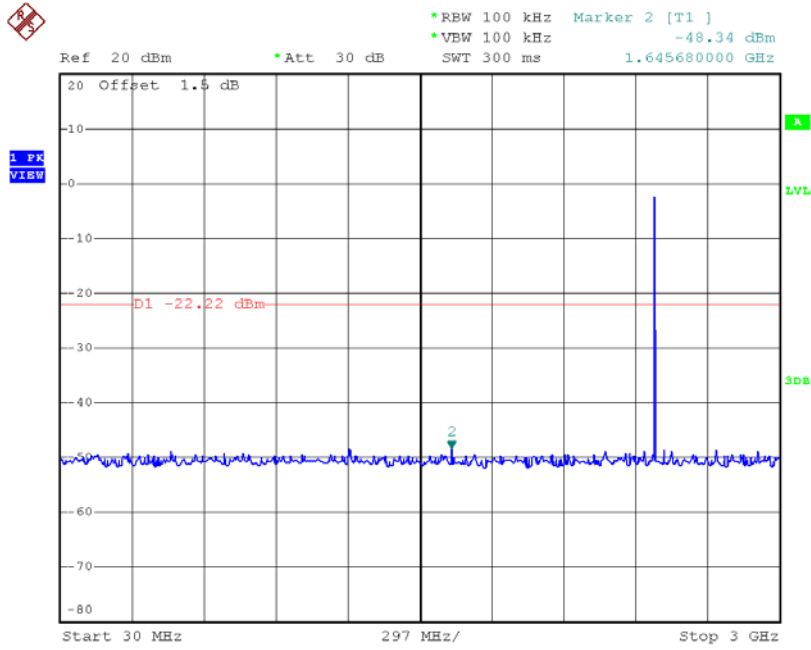

Date: 2.JUL.2018 19:12:22

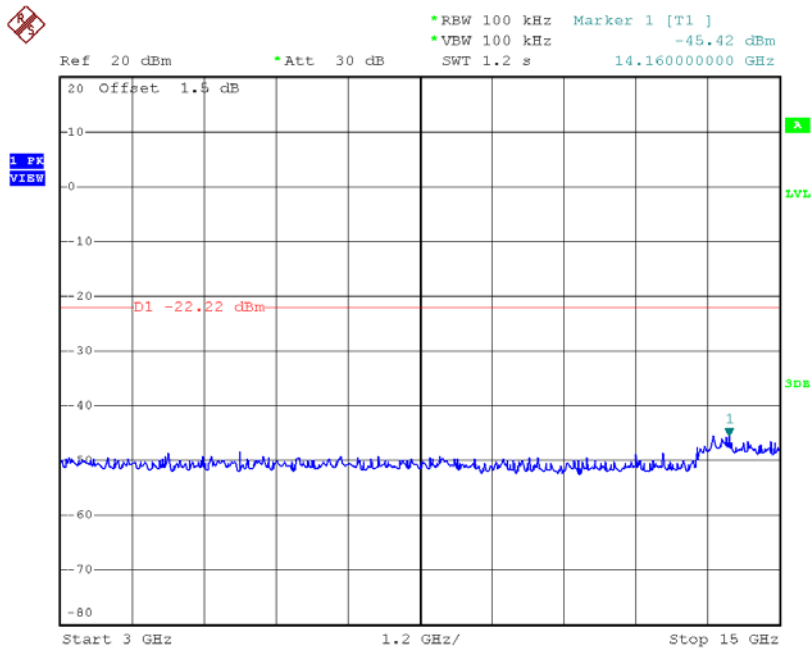

Date: 2.JUL.2018 19:12:31

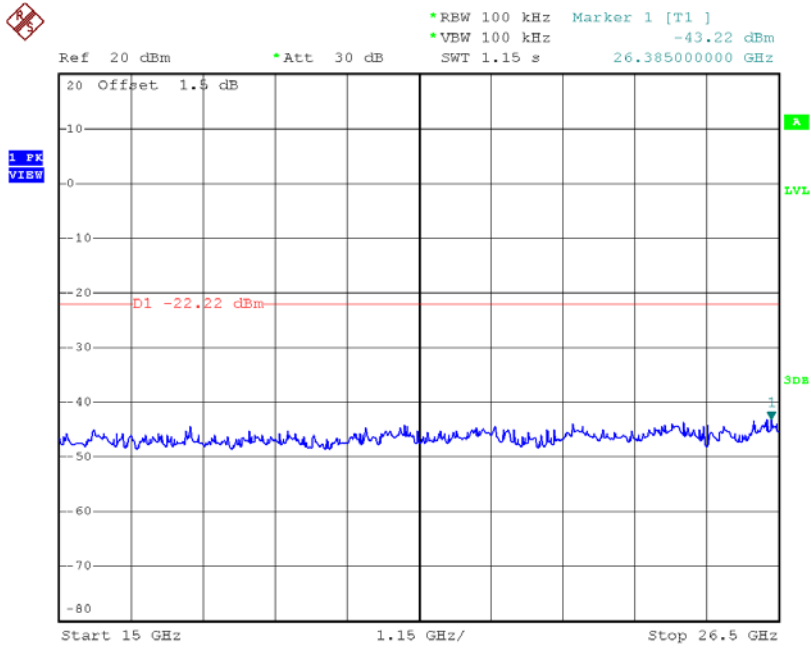

Date: 2.JUL.2018 19:12:39