

# FCC Radio Test Report

## FCC ID: KA2CS8526LHB1

**Report No.** : BTL-FCCP-5-2404H026  
**Equipment** : 2K QHD Pan & Tilt Wi-Fi Camera  
**Model Name** : DCS-8526LH  
**Brand Name** : D-Link  
**Applicant** : D-Link Corporation  
**Address** : 14420 Myford Road Suite 100, Irvine, California 92606, United States

**Radio Function** : Bluetooth Low Energy (5.0)

**FCC Rule Part(s)** : FCC CFR Title 47, Part 15, Subpart C (15.247)  
**Measurement Procedure(s)** : ANSI C63.10-2013

**Date of Receipt** : 2024/8/06  
**Date of Test** : 2024/8/07 ~ 2024/8/27  
**Issued Date** : 2024/10/18

The above equipment has been tested and found in compliance with the requirement of the above standards by BTL Inc.

**Prepared by** : Poken Huang  
 Poken Huang, Engineer

**Approved by** : Peter Chen  
 Peter Chen, Manager



**BTL Inc.**  
 No. 64, Ln. 169, Sec.2, Datong Rd., Xizhi Dist., New Taipei City  
 Tel: +886-2-8692-6160 Fax: +886-2-8692-6170 Web: www.newbtl.com Service mail: btl\_qa@newbtl.com

**Declaration**

**BTL** represents to the client that testing is done in accordance with standard procedures as applicable and that test instruments used has been calibrated with standards traceable to international standard(s) and/or national standard(s).

**BTL's** reports apply only to the specific samples tested under conditions. It is manufacture's responsibility to ensure that additional production units of this model are manufactured with the identical electrical and mechanical components. **BTL** assumes no responsibility for the data provided by the Customer, any statements, inferences or generalizations drawn by the customer or others from the reports issued by **BTL**.

This report is the confidential property of the client. As a mutual protection to the clients, the public and ourselves, the test report shall not be reproduced, except in full, without our written approval.

**BTL's** laboratory quality assurance procedures are in compliance with the **ISO/IEC 17025** requirements, and accredited by the conformity assessment authorities listed in this test report.

**BTL** is not responsible for the sampling stage, so the results only apply to the sample as received.

The information, data and test plan are provided by manufacturer which may affect the validity of results, so it is manufacturer's responsibility to ensure that the apparatus meets the essential requirements of applied standards and in all the possible configurations as representative of its intended use.

**Limitation**

For the use of the authority's logo is limited unless the Test Standard(s)/Scope(s)/Item(s) mentioned in this test report is (are) included in the conformity assessment authorities acceptance respective.

Please note that the measurement uncertainty is provided for informational purpose only and are not use in determining the Pass/Fail results.

**CONTENTS**

REVISION HISTORY	5
1 SUMMARY OF TEST RESULTS	6
1.1 TEST FACILITY	7
1.2 MEASUREMENT UNCERTAINTY	7
1.3 TEST ENVIRONMENT CONDITIONS	7
1.4 TABLE OF PARAMETERS OF TEXT SOFTWARE SETTING	8
2 GENERAL INFORMATION	9
2.1 DESCRIPTION OF EUT	9
2.2 TEST MODES	11
2.3 BLOCK DIAGRAM SHOWING THE CONFIGURATION OF SYSTEM TESTED	12
2.4 SUPPORT UNITS	13
3 AC POWER LINE CONDUCTED EMISSIONS TEST	14
3.1 LIMIT	14
3.2 TEST PROCEDURE	14
3.3 DEVIATION FROM TEST STANDARD	14
3.4 TEST SETUP	15
3.5 TEST RESULT	15
4 RADIATED EMISSIONS TEST	16
4.1 LIMIT	16
4.2 TEST PROCEDURE	17
4.3 DEVIATION FROM TEST STANDARD	17
4.4 TEST SETUP	18
4.5 EUT OPERATING CONDITIONS	19
4.6 TEST RESULT – BELOW 30 MHZ	19
4.7 TEST RESULT – 30 MHZ TO 1 GHZ	19
4.8 TEST RESULT – ABOVE 1 GHZ	19
5 BANDWIDTH TEST	20
5.1 APPLIED PROCEDURES / LIMIT	20
5.2 TEST PROCEDURE	20
5.3 DEVIATION FROM STANDARD	20
5.4 TEST SETUP	20
5.5 EUT OPERATION CONDITIONS	20
5.6 TEST RESULTS	20
6 MAXIMUM OUTPUT POWER TEST	21
6.1 APPLIED PROCEDURES / LIMIT	21
6.2 TEST PROCEDURE	21
6.3 DEVIATION FROM STANDARD	21
6.4 TEST SETUP	21
6.5 EUT OPERATION CONDITIONS	21
6.6 TEST RESULTS	21
7 POWER SPECTRAL DENSITY TEST	22
7.1 APPLIED PROCEDURES / LIMIT	22
7.2 TEST PROCEDURE	22
7.3 DEVIATION FROM STANDARD	22
7.4 TEST SETUP	22
7.5 EUT OPERATION CONDITIONS	22
7.6 TEST RESULTS	22

8	ANTENNA CONDUCTED SPURIOUS EMISSION	23
8.1	APPLIED PROCEDURES / LIMIT	23
8.2	TEST PROCEDURE	23
8.3	DEVIATION FROM STANDARD	23
8.4	TEST SETUP	23
8.5	EUT OPERATION CONDITIONS	23
8.6	TEST RESULTS	23
9	LIST OF MEASURING EQUIPMENTS	24
10	EUT TEST PHOTO	26
11	EUT PHOTOS	26
APPENDIX A	AC POWER LINE CONDUCTED EMISSIONS	27
APPENDIX B	RADIATED EMISSIONS - 30 MHZ TO 1 GHZ	30
APPENDIX C	RADIATED EMISSIONS - ABOVE 1 GHZ	35
APPENDIX D	BANDWIDTH	46
APPENDIX E	MAXIMUM OUTPUT POWER	48
APPENDIX F	POWER SPECTRAL DENSITY TEST	50
APPENDIX G	ANTENNA CONDUCTED SPURIOUS EMISSION	52

### REVISION HISTORY

Report No.	Version	Description	Issued Date	Note
BTL-FCCP-5-22404H026	R00	Original Report.	2024/10/18	Valid

## 1 SUMMARY OF TEST RESULTS

Test procedures according to the technical standards.

Standard(s) Section	Description	Test Result	Judgement	Remark
15.207	AC Power Line Conducted Emissions	APPENDIX A	Pass	-----
15.205 15.209 15.247(d)	Radiated Emissions	APPENDIX B APPENDIX C	Pass	-----
15.247(a)(2)	Bandwidth	APPENDIX D	Pass	-----
15.247(b)(3)	Maximum Output Power	APPENDIX E	Pass	-----
15.247(e)	Power Spectral Density	APPENDIX F	Pass	-----
15.247(d)	Antenna conducted Spurious Emission	APPENDIX G	Pass	-----
15.203	Antenna Requirement	-----	Pass	<b>NOTE (3)</b>

**NOTE:**

- (1) "N/A" denotes test is not applicable in this Test Report.
- (2) The report format version is TP.1.1.1.
- (3) The device what use replaceable antennas with non-standard interfaces are considered sufficient to comply with the provisions of 15.203.

### 1.1 TEST FACILITY

The test locations stated below are under the TAF Accreditation Number 0659.

The test location(s) used to collect the test data in this report are:

(FCC DN: TW0659)

No. 64, Ln. 169, Sec.2, Datong Rd., Xizhi Dist., New Taipei City

C01       CB20       TR01

### 1.2 MEASUREMENT UNCERTAINTY

The reported uncertainty of measurement  $y \pm U$ , where expanded uncertainty  $U$  is based on a standard uncertainty multiplied by a coverage factor of  $k = 2$ , providing a level of confidence of approximately **95 %**.

The measurement instrumentation uncertainty considerations contained in CISPR 16-4-2. The BTL measurement uncertainty is less than the CISPR 16-4-2  $U_{\text{cispr}}$  requirement.

#### A. AC power line conducted emissions test:

Test Site	Method	Measurement Frequency Range	U (dB)
C06	CISPR	150 kHz ~ 30MHz	2.4498

#### B. Radiated emissions test:

Test Site	Measurement Frequency Range	U,(dB)
CB21	0.03 GHz ~ 0.2 GHz	4.17
	0.2 GHz ~ 1 GHz	4.72
	1 GHz ~ 6 GHz	5.20
	6 GHz ~ 18 GHz	5.50
	18 GHz ~ 26 GHz	3.69
	26 GHz ~ 40 GHz	4.23

#### C. Conducted test:

Test Item	U,(dB)
Occupied Bandwidth	0.53
Maximum Output Power	0.37
Power Spectral Density	0.66
Conducted Spurious emissions	0.53
Conducted Band edges	0.53

#### NOTE:

Unless specifically mentioned, the uncertainty of measurement has not been taken into account to declare the compliance or non-compliance to the specification.

### 1.3 TEST ENVIRONMENT CONDITIONS

Test Item	Environment Condition	Test Voltage	Tested by
AC Power Line Conducted Emissions	25°C, 45%	AC 120V	Ken Lu
Radiated emissions below 1 GHz	25°C, 65%	AC 120V	Barry Tsui
Radiated emissions above 1 GHz	25°C, 65%	AC 120V	Barry Tsui
Bandwidth	25°C, 79%	AC 120V	Cai Hu
Maximum Output Power	25°C, 79%	AC 120V	Cai Hu
Power Spectral Density	25°C, 79%	AC 120V	Cai Hu
Antenna conducted Spurious Emission	25°C, 79%	AC 120V	Cai Hu

**1.4 TABLE OF PARAMETERS OF TEXT SOFTWARE SETTING**

Test Software	putty			
Modulation Mode	2402 MHz	2440 MHz	2480 MHz	Data Rate
1 Mbps	DEF	DEF	DEF	1 Mbps



## 2 GENERAL INFORMATION

### 2.1 DESCRIPTION OF EUT

Equipment	2K QHD Pan & Tilt Wi-Fi Camera
Brand Name	D-Link
Model Name	DCS-8526LH
Model Difference(s)	N/A
Hardware Version	N/A
Software Version	N/A
Power Source	DC Voltage supplied from AC/DC adapter Brand/Model: KEYU/ KA12C-0502000US
Power Rating	I/P: 100-240V~50/60Hz 0.35A Max    O/P: 5V $\overline{\text{---}}$ 2000mA
Operation Band	2400 MHz ~ 2483.5 MHz
Operation Frequency	2402 MHz ~ 2480 MHz
Modulation Technology	GFSK
Transfer Rate	1Mbps
Output Power Max.	1Mbps: 5.02 dBm (0.0032 W)

**NOTE:**

- (1) The above EUT information is declared by manufacturer and for more detailed features description, please refers to the manufacturer's specifications or user's manual.

## (2) Channel List:

Channel	Frequency (MHz)	Channel	Frequency (MHz)
00	2402	20	2442
01	2404	21	2444
02	2406	22	2446
03	2408	23	2448
04	2410	24	2450
05	2412	25	2452
06	2414	26	2454
07	2416	27	2456
08	2418	28	2458
09	2420	29	2460
10	2422	30	2462
11	2424	31	2464
12	2426	32	2466
13	2428	33	2468
14	2430	34	2470
15	2432	35	2472
16	2434	36	2474
17	2436	37	2476
18	2438	38	2478
19	2440	39	2480

## (3) Table for Filed Antenna:

Ant.	Manufacturer	P/N	Type	Connector	Gain (dBi)
1		EP07401	PIFA	N/A	-3.51

(4) The above Antenna information are derived from the antenna data sheet provided by manufacturer and for more detailed features description, please refer to the manufacturer's specifications, the laboratory shall not be held responsible.

## 2.2 TEST MODES

Test Items	Test mode	Channel	Note
AC power line conducted emissions	Normal	-	-
Transmitter Radiated Emissions (below 1GHz)	1 Mbps	39	-
Transmitter Radiated Emissions (above 1GHz)	1 Mbps	00/39	Bandedge
	1 Mbps	00/19/39	Harmonic
Bandwidth	1 Mbps	00/19/39	-
Maximum Output Power	1 Mbps	00/19/39	-
Power Spectral Density	1 Mbps	00/19/39	-
Antenna conducted Spurious Emission	1 Mbps	00/19/39	-

**NOTE:**

- (1) For radiated emission band edge test, both Vertical and Horizontal are evaluated, but only the worst case (Vertical) is recorded.
- (2) For radiated emission above 1 GHz test, the spurious points of 1GHz~26.5GHz have been pre-tested and in this report only recorded the worst case.
- (3) For radiated emissions below 1 GHz test, the 1 Mbps channel 39 is found to be the worst case and recorded.

**2.3 BLOCK DIAGRAM SHOWING THE CONFIGURATION OF SYSTEM TESTED**

Equipment letters and Cable numbers refer to item numbers described in the tables of clause 2.4.

AC power line conducted emissions

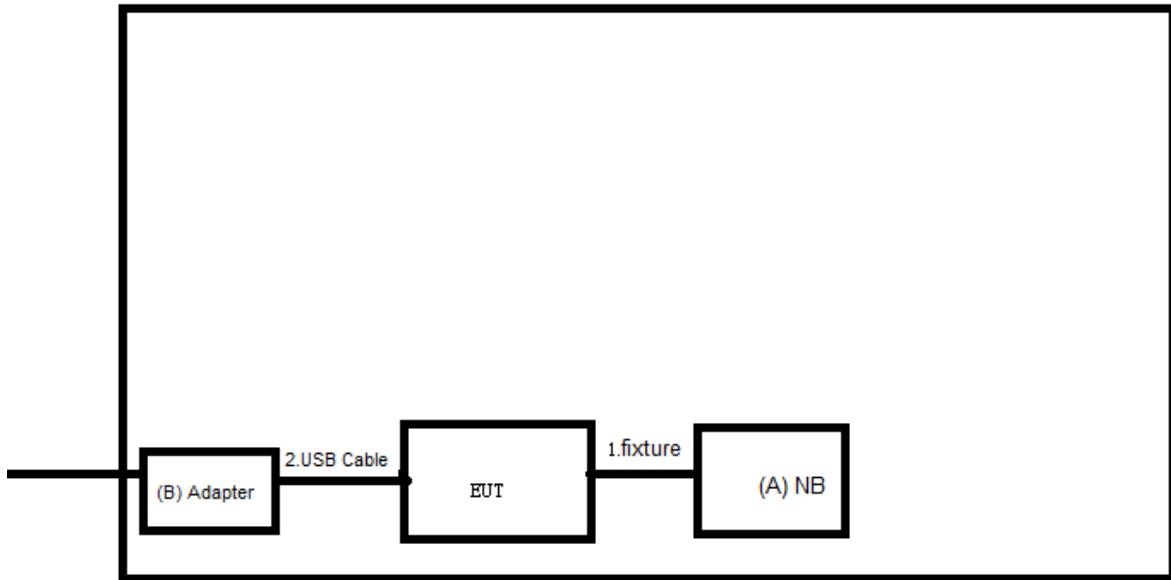

Radiated Emissions

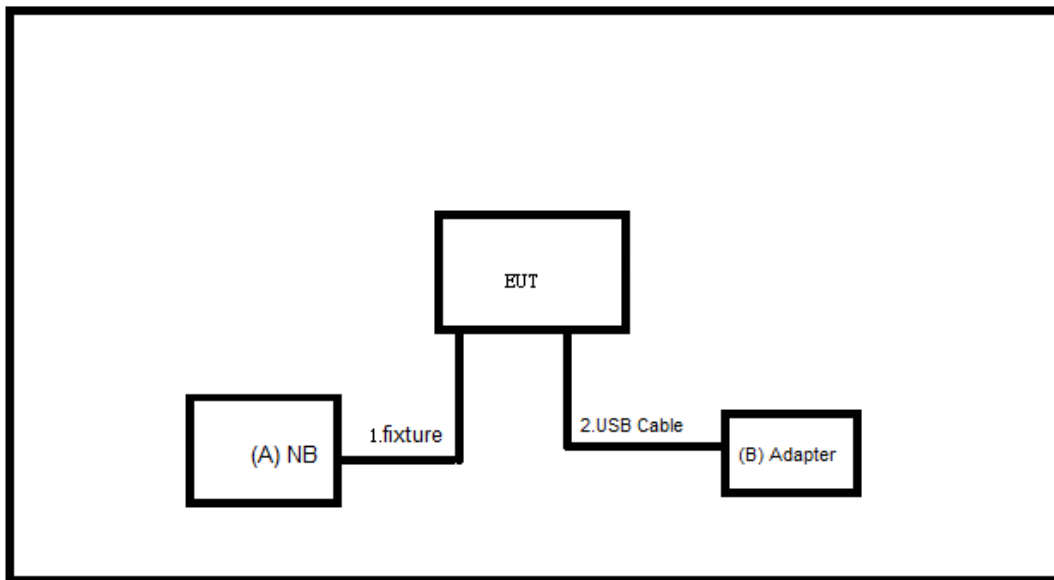

**2.4 SUPPORT UNITS**
**AC power line conducted emissions**

Item	Equipment	Brand	Model No.	Series No.	Remarks
A	Notebook	Lenovo	ThinkBook 14 G4 IAP	MP28KHAH	Furnished by test lab.
B	Adapter	N/A	N/A	N/A	Supplied by test requester.

Item	Shielded	Ferrite Core	Length	Cable Type	Remarks
1	fixture	N	N	0.3m	Furnished by test lab.
2	USB Cable	N	N	2 m	Supplied by test requester.

**Radiated Emissions**

Item	Equipment	Brand	Model No.	Series No.	Remarks
A	Notebook	Lenovo	ThinkBook 14 G4 IAP	MP28KHAH	Furnished by test lab.
B	Adapter	N/A	N/A	N/A	Supplied by test requester.

Item	Shielded	Ferrite Core	Length	Cable Type	Remarks
1	fixture	N	N	0.3m	Furnished by test lab.
2	USB Cable	N	N	2 m	Supplied by test requester.

### 3 AC POWER LINE CONDUCTED EMISSIONS TEST

#### 3.1 LIMIT

Frequency (MHz)	Limit (dB $\mu$ V)	
	Quasi-peak	Average
0.15 - 0.5	66 - 56 *	56 - 46 *
0.50 - 5.0	56	46
5.0 - 30.0	60	50

**NOTE:**

- (1) The tighter limit applies at the band edges.
- (2) The limit of " \* " marked band means the limitation decreases linearly with the logarithm of the frequency in the range.
- (3) The test result calculated as following:  
 Measurement Value = Reading Level + Correct Factor  
 Correct Factor = Insertion Loss + Cable Loss + Attenuator Factor (if use)  
 Margin Level = Measurement Value – Limit Value  
 Calculation example:

Reading Level		Correct Factor		Measurement Value
38.22	+	3.45	=	41.67

Measurement Value		Limit Value		Margin Level
41.67	-	60	=	-18.33

The following table is the setting of the receiver.

Receiver Parameter	Setting
Attenuation	10 dB
Start Frequency	0.15 MHz
Stop Frequency	30 MHz
IF Bandwidth	9 KHz

#### 3.2 TEST PROCEDURE

- a. The EUT was placed 0.8 m above the horizontal ground plane with the EUT being connected to the power mains through a line impedance stabilization network (LISN).  
 All other support equipment were powered from an additional LISN(s).  
 The LISN provides 50 Ohm/50uH of impedance for the measuring instrument.
- b. Interconnecting cables that hang closer than 40 cm to the ground plane shall be folded back and forth in the center forming a bundle to keep the cable above 40 cm.
- c. Excess I/O cables that are not connected to a peripheral shall be bundled in the center.  
 The end of the cable will be terminated, using the correct terminating impedance.  
 The overall length shall not exceed 1 m.
- d. The LISN is spaced at least 80 cm from the nearest part of the EUT chassis.
- e. For the actual test configuration, please refer to the related Item – EUT TEST PHOTO.

**NOTE:**

- (1) In the results, each reading is marked as Peak, QP or AVG per the detector used.  
 BW=9 kHz (6 dB Bandwidth)
- (2) All readings are Peak unless otherwise stated QP or AVG in column of Note. Both the QP and the AVG readings must be less than the limit for compliance.

#### 3.3 DEVIATION FROM TEST STANDARD

No deviation.

### 3.4 TEST SETUP

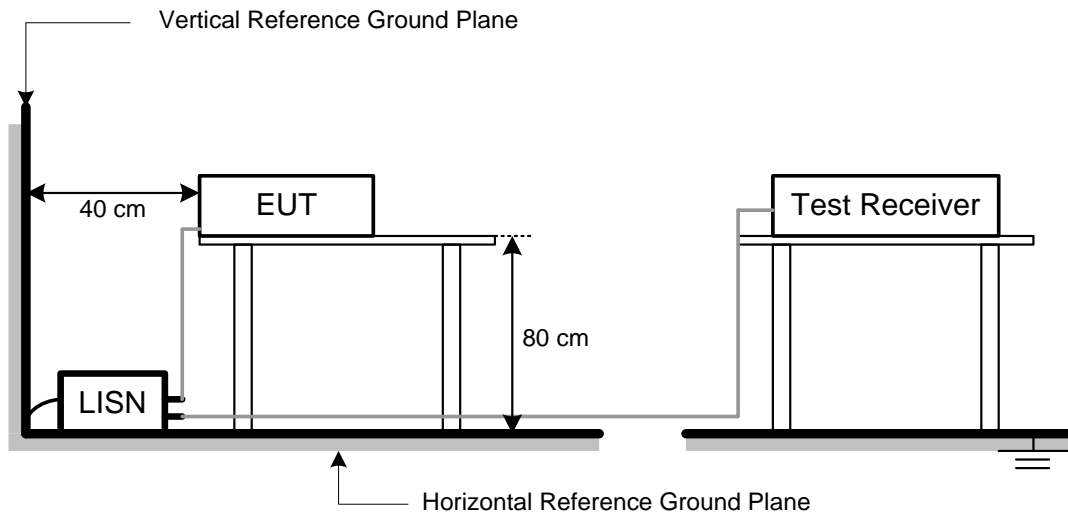

### 3.5 TEST RESULT

Please refer to the **APPENDIX A**.

## 4 RADIATED EMISSIONS TEST

### 4.1 LIMIT

In case the emission fall within the restricted band specified on 15.205, then the 15.209 limit in the table below has to be followed.

#### LIMITS OF RADIATED EMISSIONS MEASUREMENT (9 kHz to 1000 MHz)

Frequency (MHz)	Field Strength (microvolts/meter)	Measurement Distance (meters)
0.009~0.490	2400/F(KHz)	300
0.490~1.705	24000/F(KHz)	30
1.705~30.0	30	30
30~88	100	3
88~216	150	3
216~960	200	3
960~1000	500	3

#### LIMITS OF RADIATED EMISSIONS MEASUREMENT (Above 1000 MHz)

Frequency (MHz)	Radiated Emissions (dBuV/m)		Measurement Distance (meters)
	Peak	Average	
Above 1000	74	54	3

#### NOTE:

- (1) The limit for radiated test was performed according to FCC CFR Title 47, Part 15, Subpart C.
- (2) The tighter limit applies at the band edges.
- (3) Emission level (dBuV/m)=20log Emission level (uV/m).
- (4) The test result calculated as following:  
 Measurement Value = Reading Level + Correct Factor  
 Correct Factor = Antenna Factor + Cable Loss - Amplifier Gain(if use)  
 Margin Level = Measurement Value - Limit Value  
 Calculation example:

Reading Level		Correct Factor		Measurement Value
41.91	+	-8.36	=	33.55

Measurement Value		Limit Value		Margin Level
33.55	-	43.50	=	-9.95

Spectrum Parameter	Setting
Attenuation	Auto
Start Frequency	1000 MHz
Stop Frequency	10th carrier harmonic
RBW / VBW (Emission in restricted band)	1MHz / 3MHz for Peak, 1MHz / 1/T for Average

Spectrum Parameter	Setting
Attenuation	Auto
Start ~ Stop Frequency	9KHz~90KHz for PK/AVG detector
Start ~ Stop Frequency	90KHz~110KHz for QP detector
Start ~ Stop Frequency	110KHz~490KHz for PK/AVG detector
Start ~ Stop Frequency	490KHz~30MHz for QP detector
Start ~ Stop Frequency	30MHz~1000MHz for QP detector



#### 4.2 TEST PROCEDURE

- a. The measuring distance of 3 m shall be used for measurements. The EUT was placed on the top of a rotating table 0.8 meter above the ground at a 3 meter semi-anechoic chamber. The table was rotated 360 degrees to determine the position of the highest radiation.(below 1GHz)
- b. The measuring distance of 3 m shall be used for measurements. The EUT was placed on the top of a rotating table 1.5 meter above the ground at a 3 meter semi-anechoic chamber. The table was rotated 360 degrees to determine the position of the highest radiation.(above 1GHz)
- c. The height of the equipment or of the substitution antenna shall be 0.8 m or 1.5 m, the height of the test antenna shall vary between 1 m to 4 m. Both horizontal and vertical polarizations of the antenna are set to make the measurement.
- d. For each suspected emission, the EUT was arranged to its worst case and then the antenna was tuned to heights find the maximum reading (used Bore sight function).
- e. The receiver system was set to peak and average detect function and specified bandwidth with maximum hold mode when the test frequency is above 1GHz.
- f. The initial step in collecting radiated emission data is a receiver peak detector mode pre-scanning the measurement frequency range. Significant peaks are then marked and then Quasi Peak detector mode re-measured.
- g. All readings are Peak unless otherwise stated QP in column of Note. Peak denotes that the Peak reading compliance with the QP Limits and then QP Mode measurement didn't perform. (below 1GHz)
- h. All readings are Peak Mode value unless otherwise stated AVG in column of Note. If the Peak Mode Measured value compliance with the Peak Limits and lower than AVG Limits, the EUT shall be deemed to meet both Peak & AVG Limits and then only Peak Mode was measured, but AVG Mode didn't perform. (above 1GHz)
- i. For the actual test configuration, please refer to the related Item – EUT TEST PHOTO.

#### 4.3 DEVIATION FROM TEST STANDARD

No deviation.

## 4.4 TEST SETUP

### 9 kHz to 30 MHz

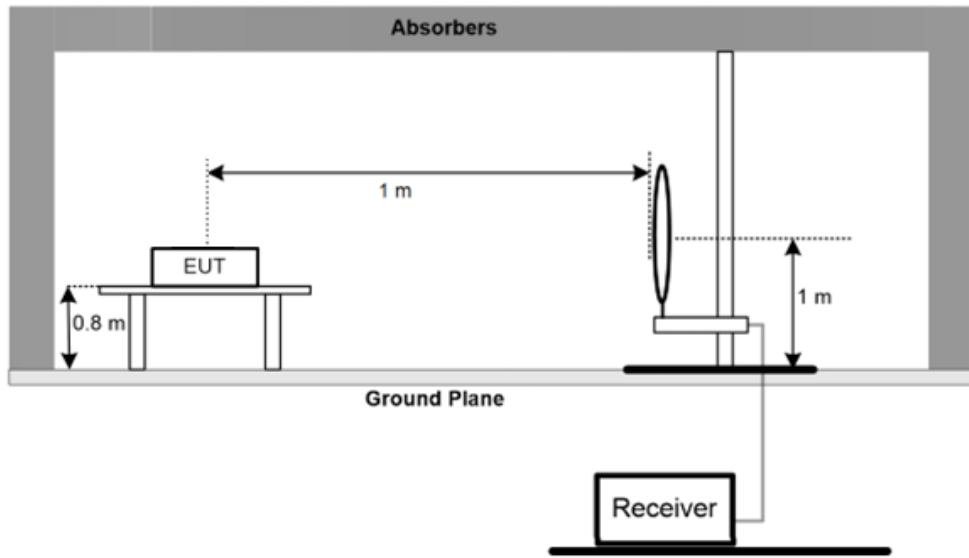

### 30 MHz to 1 GHz

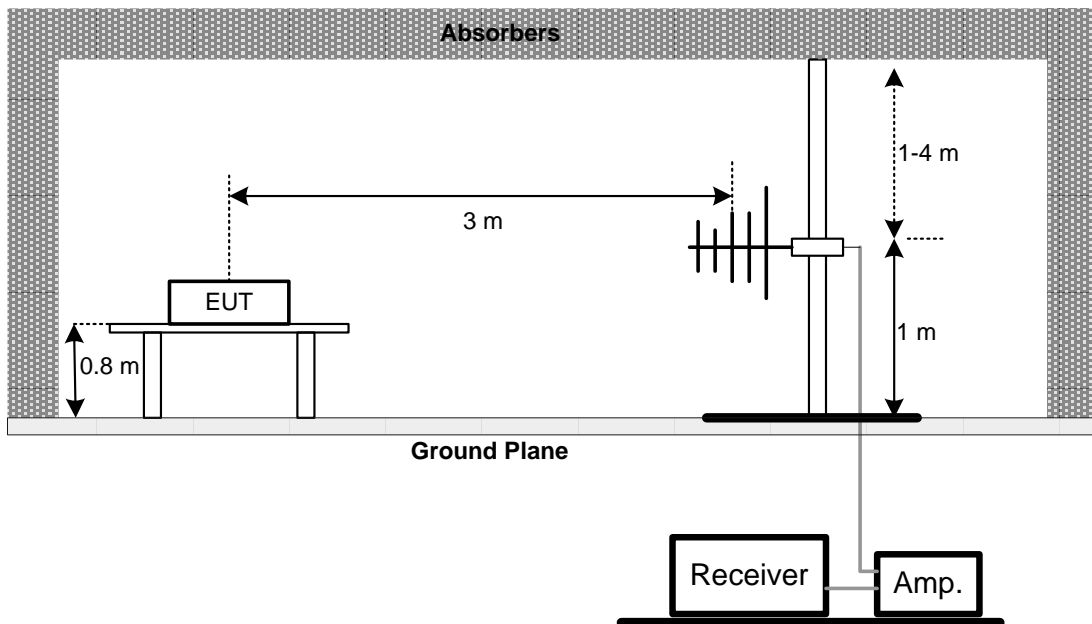

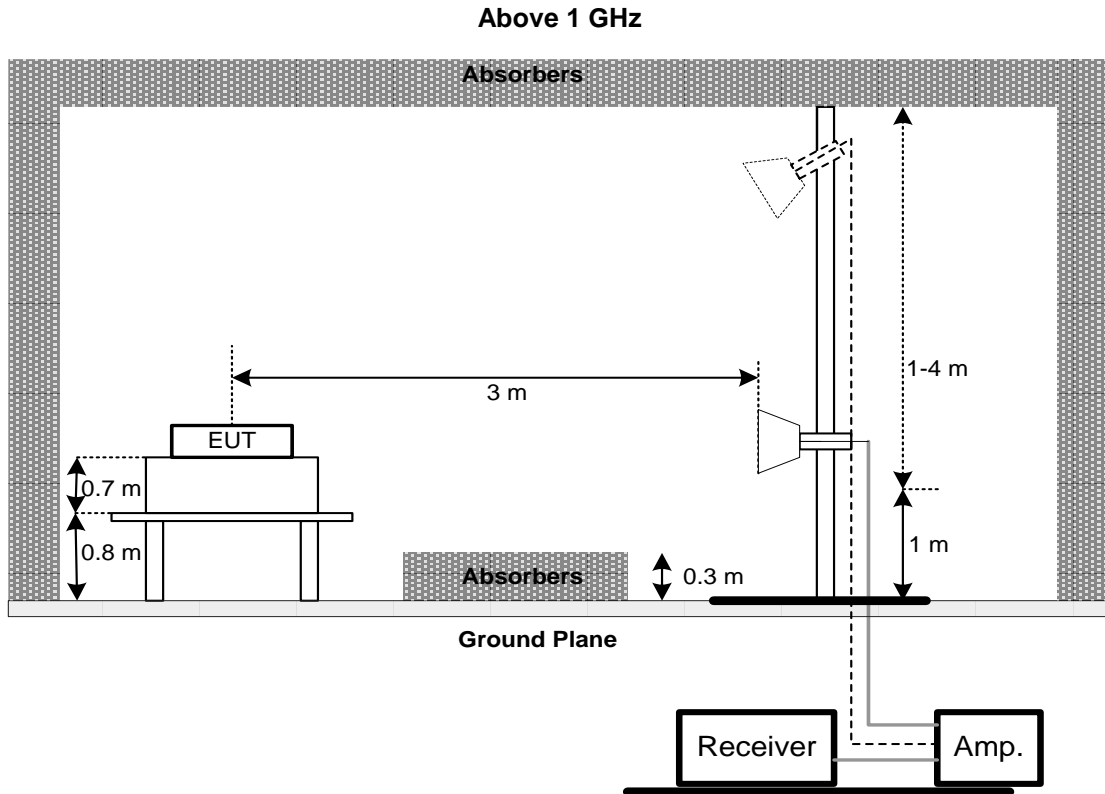

**4.5 EUT OPERATING CONDITIONS**

The EUT was programmed to be in continuously transmitting mode.

**4.6 TEST RESULT – BELOW 30 MHZ**

Please refer to the APPENDIX B.

**4.7 TEST RESULT – 30 MHZ TO 1 GHZ**

Please refer to the APPENDIX B.

**4.8 TEST RESULT – ABOVE 1 GHZ**

Please refer to the APPENDIX C.

**NOTE:**

- (1) No limit: This is fundamental signal, the judgment is not applicable. For fundamental signal judgment was referred to Peak output test.

## 5 BANDWIDTH TEST

### 5.1 APPLIED PROCEDURES / LIMIT

Section	Test Item	Limit
15.247(a)(2)	6 dB Bandwidth	500 kHz

### 5.2 TEST PROCEDURE

- The EUT was directly connected to the spectrum analyzer and antenna output port as show in the block diagram below,
- Spectrum Setting : RBW= 100KHz, VBW=300KHz, Sweep time = 2.5 ms.

### 5.3 DEVIATION FROM STANDARD

No deviation.

### 5.4 TEST SETUP



### 5.5 EUT OPERATION CONDITIONS

The EUT was programmed to be in continuously transmitting mode.

### 5.6 TEST RESULTS

Please refer to the APPENDIX D.

## 6 MAXIMUM OUTPUT POWER TEST

### 6.1 APPLIED PROCEDURES / LIMIT

Section	Test Item	Limit
15.247(b)(3)	Maximum Output Power	1 Watt or 30dBm

### 6.2 TEST PROCEDURE

- a. The EUT was directly connected to the power meter and antenna output port as show in the block diagram below,
- b. The maximum peak conducted output power was performed in accordance with FCC KDB 558074 D01 15.247 Meas Guidance.

### 6.3 DEVIATION FROM STANDARD

No deviation.

### 6.4 TEST SETUP

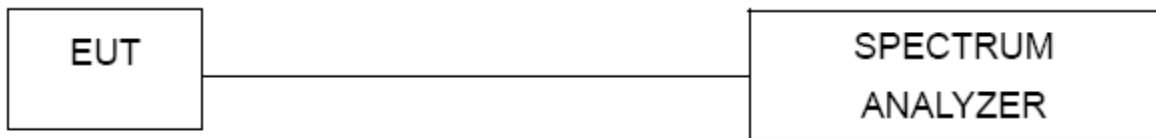

### 6.5 EUT OPERATION CONDITIONS

The EUT was programmed to be in continuously transmitting mode.

### 6.6 TEST RESULTS

Please refer to the APPENDIX E.

## 7 POWER SPECTRAL DENSITY TEST

### 7.1 APPLIED PROCEDURES / LIMIT

Section	Test Item	Limit
15.247(e)	Power Spectral Density	8 dBm (in any 3 kHz)

### 7.2 TEST PROCEDURE

- a. The EUT was directly connected to the spectrum analyzer and antenna output port as show in the block diagram below,
- b. Spectrum Setting: RBW=3KHz, VBW=10 KHz, Sweep time = auto.

### 7.3 DEVIATION FROM STANDARD

No deviation.

### 7.4 TEST SETUP



### 7.5 EUT OPERATION CONDITIONS

The EUT was programmed to be in continuously transmitting mode.

### 7.6 TEST RESULTS

Please refer to the APPENDIX F.

## 8 ANTENNA CONDUCTED SPURIOUS EMISSION

### 8.1 APPLIED PROCEDURES / LIMIT

In any 100 kHz bandwidth outside the frequency band in which the spread spectrum or digitally modulated device is operating, the RF power that is produced shall be at least 20 dB below that in the 100 kHz bandwidth within the band that contains the highest level of the desired power, based on either an RF conducted or a radiated measurement, provided that the transmitter demonstrates compliance with the peak conducted power limits.

### 8.2 TEST PROCEDURE

- a. The EUT was directly connected to the spectrum analyzer and antenna output port as show in the block diagram below,
- b. Spectrum Setting : RBW= 100KHz, VBW=300KHz, Sweep time = 10 ms.

### 8.3 DEVIATION FROM STANDARD

No deviation.

### 8.4 TEST SETUP



### 8.5 EUT OPERATION CONDITIONS

The EUT was programmed to be in continuously transmitting mode.

### 8.6 TEST RESULTS

Please refer to the APPENDIX G.

## 9 LIST OF MEASURING EQUIPMENTS

AC Power Line Conducted Emissions						
Item	Kind of Equipment	Manufacturer	Type No.	Serial No.	Calibrated Date	Calibrated Until
1	Two-Line V-Network	R&S	ENV216	101051	2024/6/26	2025/6/25
2	Test Cable	EMCI	EMCRG58-BM-B M-9000	210501	2023/12/11	2024/12/10
3	EMC Receiver	Keysight	N9038A	MY54130009	2024/6/27	2025/6/26
4	Measurement Software	Farad	EZ EMC (Ver. NB-03A1-01)	N/A	N/A	N/A

Radiated Emissions Below 1GHz						
Item	Kind of Equipment	Manufacturer	Type No.	Serial No.	Calibrated Date	Calibrated Until
1	Loop Ant.	Electro-Metrics	EMCI-LPA600	274	2024/7/5	2025/7/4
2	EMC Receiver	Keysight	N9038A	MY54130009	2024/6/27	2025/6/26
3	Pre-Amplifier	EMCI	EMC001340	980555	2023/12/1	2024/11/30
4	Trilog-Broadband Antenna	Schwarzbeck	VULB 9168	01207	2023/12/18	2024/12/17
5	EMC Receiver	Keysight	N9038A	MY54130009	2024/6/27	2025/6/26
6	Pre-Amplifier	EMCI	EMC001330-2020 1222	980807	2023/12/11	2024/12/10
7	Test Cable	EMCI	EMC-8D-NM-NM-5000	150106	2023/12/11	2024/12/10
8	Test Cable	EMCI	EMC-CFD-400-N M-NM-8000	200348	2023/12/11	2024/12/10
9	Measurement Software	Farad	EZ EMC (Ver. NB-03A1-01)	N/A	N/A	N/A

Radiated Emissions Above 1 GHz						
Item	Kind of Equipment	Manufacturer	Type No.	Serial No.	Calibrated Date	Calibrated Until
1	Broad-Band Horn Antenna	RFSPIN	DRH18-E	210109A18E	2024/1/10	2025/1/9
2	Pre-Amplifier	EMCI	EMC051845SE	980779	2023/12/11	2024/12/10
3	Test Cable	EMCI	EMC105-SM-SM-1000	210119	2023/12/11	2024/12/10
4	Test Cable	EMCI	EMC105-SM-SM-3000	210118	2023/12/11	2024/12/10
5	Test Cable	EMCI	EMC105-SM-SM-7000	210117	2023/12/11	2024/12/10
6	EXA Spectrum Analyzer	keysight	N9010A	MY56480554	2023/9/12	2024/9/11
7	Pre-Amplifier	EMCI	EMC184045SE	980512	2023/12/11	2024/12/10
8	Broad-Band Horn Antenna	Schwarzbeck	BBHA 9170	340	2024/6/27	2025/6/26
9	Test Cable	EMCI	EMC102-KM-KM-1000	220328	2023/12/11	2024/12/10
10	Test Cable	EMCI	EMC101G-KM-KM-3000	220330	2023/12/11	2024/12/10
11	Measurement Software	Farad	EZ EMC (Ver. NB-03A1-01)	N/A	N/A	N/A



Bandwidth						
Item	Kind of Equipment	Manufacturer	Type No.	Serial No.	Calibrated Date	Calibrated Until
1	Spectrum Analyzer	R&S	FSP 30	100854	2024/6/27	2025/6/26
2	10dbAttenuator	INMET	AHC-10dB	1	N/A	N/A
3	BTL-ConducredTest	N/A	1247788684	N/A	N/A	N/A

Maximum Output Power						
Item	Kind of Equipment	Manufacturer	Type No.	Serial No.	Calibrated Date	Calibrated Until
1	Spectrum Analyzer	R&S	FSP 30	100854	2024/6/27	2025/6/26
2	10dbAttenuator	INMET	AHC-10dB	1	N/A	N/A
3	BTL-ConducredTest	N/A	1247788684	N/A	N/A	N/A

Power Spectral Density						
Item	Kind of Equipment	Manufacturer	Type No.	Serial No.	Calibrated Date	Calibrated Until
1	Spectrum Analyzer	R&S	FSP 30	100854	2024/6/27	2025/6/26
2	10dbAttenuator	INMET	AHC-10dB	1	N/A	N/A
3	BTL-ConducredTest	N/A	1247788684	N/A	N/A	N/A

Antenna conducted Spurious Emission						
Item	Kind of Equipment	Manufacturer	Type No.	Serial No.	Calibrated Date	Calibrated Until
1	Spectrum Analyzer	R&S	FSP 30	100854	2024/6/27	2025/6/26
2	10dbAttenuator	INMET	AHC-10dB	1	N/A	N/A
3	BTL-ConducredTest	N/A	1247788684	N/A	N/A	N/A

Remark: "N/A" denotes no model name, no serial no. or no calibration specified.  
All calibration period of equipment list is one year.

## **10 EUT TEST PHOTO**

Please refer to document Appendix No.: TP-2404H026-FCCP-1 (APPENDIX-TEST PHOTOS).

## **11 EUT PHOTOS**

Please refer to document Appendix No.: EP-2404H026-1 (APPENDIX-EUT PHOTOS).

## APPENDIX A AC POWER LINE CONDUCTED EMISSIONS

Test Mode	Normal	Tested Date	2024/9/2
Test Frequency	-	Phase	Line
Note	KA12C-0502000US		

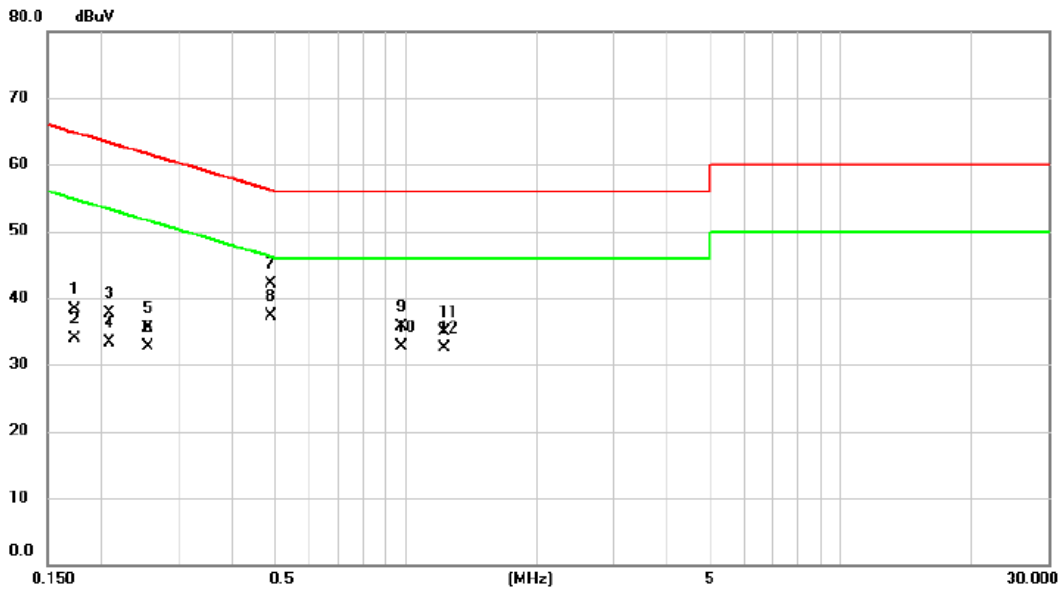

No. Mk.	Freq. MHz	Reading Level dBuV	Correct Factor dB	Measurement dBuV	Limit dBuV	Margin dB	Detector	Comment
1	0.1734	28.59	9.65	38.24	64.80	-26.56	QP	
2	0.1734	24.19	9.65	33.84	54.80	-20.96	AVG	
3	0.2088	28.15	9.64	37.79	63.25	-25.46	QP	
4	0.2088	23.74	9.64	33.38	53.25	-19.87	AVG	
5	0.2564	25.79	9.64	35.43	61.55	-26.12	QP	
6	0.2564	22.97	9.64	32.61	51.55	-18.94	AVG	
7	0.4902	32.52	9.66	42.18	56.16	-13.98	QP	
8 *	0.4902	27.63	9.66	37.29	46.16	-8.87	AVG	
9	0.9815	25.99	9.70	35.69	56.00	-20.31	QP	
10	0.9815	22.93	9.70	32.63	46.00	-13.37	AVG	
11	1.2290	25.12	9.72	34.84	56.00	-21.16	QP	
12	1.2290	22.77	9.72	32.49	46.00	-13.51	AVG	

**REMARKS:**

- (1) Measurement Value = Reading Level + Correct Factor.
- (2) Margin Level = Measurement Value - Limit Value.

Test Mode	Normal	Tested Date	2024/9/2
Test Frequency	-	Phase	Neutral
Note	KA12C-0502000US		

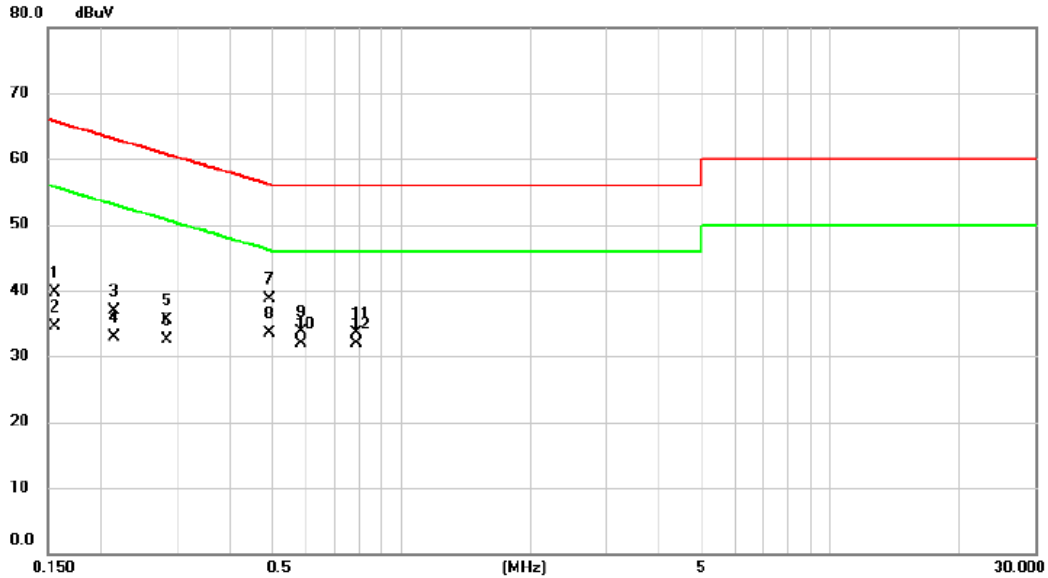

No.	Mk.	Freq. MHz	Reading Level dBuV	Correct Factor dB	Measure- ment dBuV	Limit dBuV	Margin dB	Detector	Comment
1		0.1556	30.06	9.63	39.69	65.70	-26.01	QP	
2		0.1556	24.78	9.63	34.41	55.70	-21.29	AVG	
3		0.2140	27.19	9.63	36.82	63.05	-26.23	QP	
4		0.2140	23.34	9.63	32.97	53.05	-20.08	AVG	
5		0.2850	25.84	9.64	35.48	60.67	-25.19	QP	
6		0.2850	22.88	9.64	32.52	50.67	-18.15	AVG	
7		0.4923	29.03	9.64	38.67	56.13	-17.46	QP	
8	*	0.4923	23.84	9.64	33.48	46.13	-12.65	AVG	
9		0.5855	24.04	9.65	33.69	56.00	-22.31	QP	
10		0.5855	22.30	9.65	31.95	46.00	-14.05	AVG	
11		0.7880	23.86	9.67	33.53	56.00	-22.47	QP	
12		0.7880	22.26	9.67	31.93	46.00	-14.07	AVG	

**REMARKS:**

- (1) Measurement Value = Reading Level + Correct Factor.
- (2) Margin Level = Measurement Value - Limit Value.

## **APPENDIX B RADIATED EMISSIONS - 30 MHZ TO 1 GHZ**

Test Mode	BLE (1 Mbps)	Test Date	2024/8/23
Test Frequency	CH39: 2480 MHz	Polarization	Vertical



No.	Mk.	Freq.	Reading Level	Correct Factor	Measurement	Limit	Margin	Antenna Height	Table Degree	
		MHz	dBuV	dB	dBuV/m	dBuV/m	dB	cm	degree	Comment
1		3.0081	45.44	-5.03	40.41	69.54	-29.13			peak
2		6.0071	40.49	-4.15	36.34	69.54	-33.20			peak
3		7.9866	45.13	-3.79	41.34	69.54	-28.20			peak
4		9.0063	32.81	-4.11	28.70	69.54	-40.84			peak
5	*	10.9857	47.03	-4.21	42.82	69.54	-26.72			peak
6		14.0148	33.19	-4.58	28.61	69.54	-40.93			peak

**REMARKS:**

- (1) Measurement Value = Reading Level + Correct Factor.
- (2) Margin Level = Measurement Value - Limit Value.

Test Mode	BLE (1 Mbps)	Test Date	2024/8/23
Test Frequency	CH39: 2480 MHz	Polarization	Horizontal

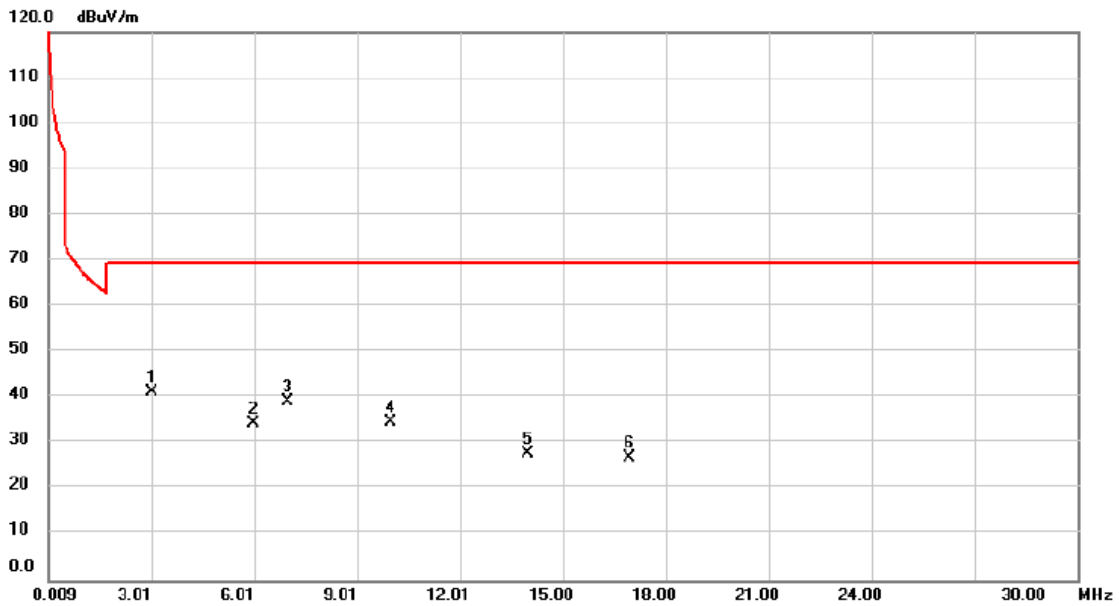

No. Mk.	Freq. MHz	Reading Level dBuV	Correct Factor dB	Measurement dBuV/m	Limit dBuV/m	Margin dB	Detector	Antenna Height cm	Table Degree	Comment
1 *	3.0081	46.37	-5.03	41.34	69.54	-28.20	peak			
2	6.0071	38.40	-4.15	34.25	69.54	-35.29	peak			
3	6.9970	43.04	-3.77	39.27	69.54	-30.27	peak			
4	9.9960	38.93	-4.13	34.80	69.54	-34.74	peak			
5	13.9848	32.42	-4.58	27.84	69.54	-41.70	peak			
6	16.9240	31.58	-4.65	26.93	69.54	-42.61	peak			

**REMARKS:**

- (1) Measurement Value = Reading Level + Correct Factor.
- (2) Margin Level = Measurement Value - Limit Value.



Test Mode	BLE (1 Mbps)	Test Date	2024/9/2
Test Frequency	CH39: 2480 MHz	Polarization	Vertical
Note	KA12C-0502000US		

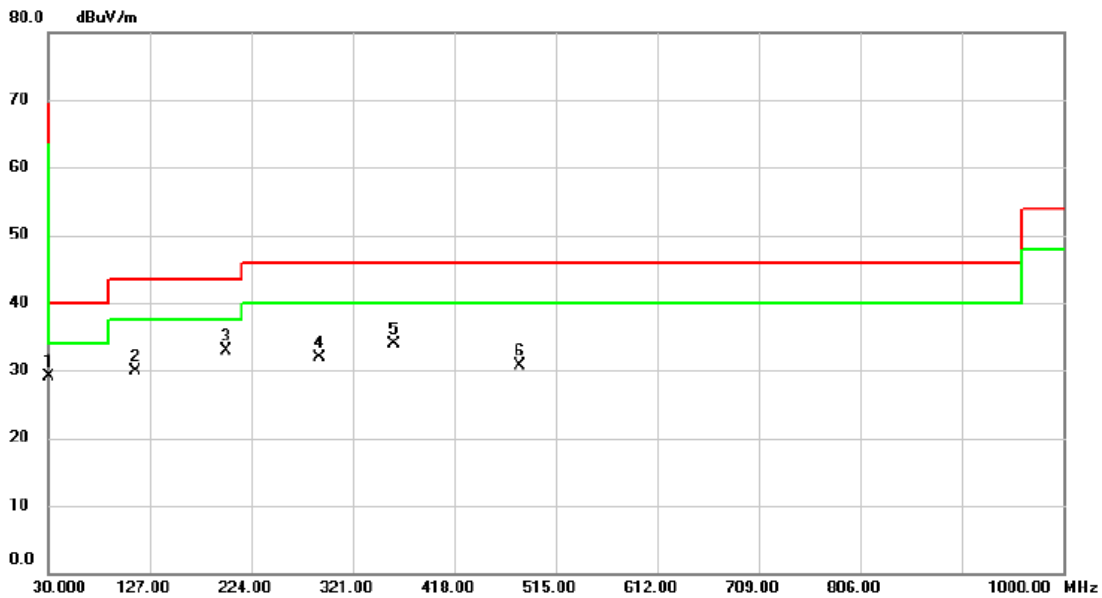

No.	Mk.	Freq. MHz	Reading Level dBuV	Correct Factor dB	Measure- ment dBuV/m	Limit dBuV/m	Margin dB	Detector	Comment
1		30.0000	42.74	-13.64	29.10	40.00	-10.90	peak	
2		113.4200	44.49	-14.53	29.96	43.50	-13.54	peak	
3	*	199.7500	47.14	-14.22	32.92	43.50	-10.58	peak	
4		288.9900	42.32	-10.39	31.93	46.00	-14.07	peak	
5		359.8000	42.51	-8.64	33.87	46.00	-12.13	peak	
6		480.0800	36.21	-5.55	30.66	46.00	-15.34	peak	

**REMARKS:**

- (1) Measurement Value = Reading Level + Correct Factor.
- (2) Margin Level = Measurement Value - Limit Value.

Test Mode	BLE (1 Mbps)	Test Date	2024/9/2
Test Frequency	CH39: 2480 MHz	Polarization	Horizontal
Note	KA12C-0502000US		

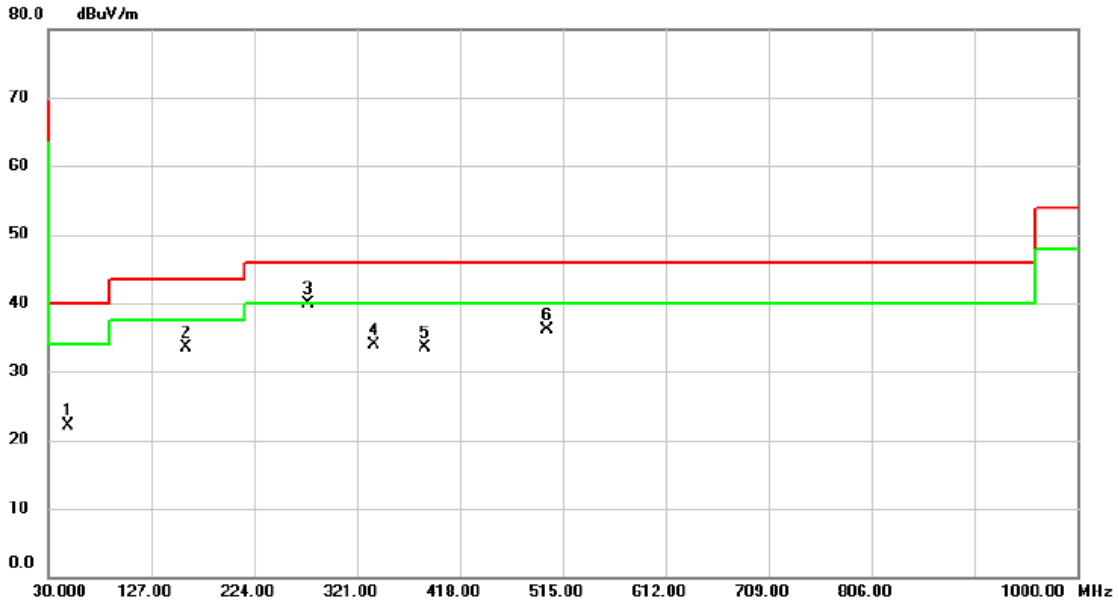

No.	Mk.	Freq. MHz	Reading Level dBuV	Correct Factor dB	Measure- ment dBuV/m	Limit dBuV/m	Margin dB	Detector	Comment
1		48.4300	33.58	-11.52	22.06	40.00	-17.94	peak	
2		159.9800	44.46	-11.05	33.41	43.50	-10.09	peak	
3	*	275.4100	50.96	-11.00	39.96	46.00	-6.04	peak	
4		337.4900	43.11	-9.25	33.86	46.00	-12.14	peak	
5		385.0200	41.36	-7.91	33.45	46.00	-12.55	peak	
6		500.4500	41.26	-5.23	36.03	46.00	-9.97	peak	

**REMARKS:**

- (1) Measurement Value = Reading Level + Correct Factor.
- (2) Margin Level = Measurement Value - Limit Value.

## **APPENDIX C RADIATED EMISSIONS - ABOVE 1 GHZ**

Test Mode	BLE (1 Mbps)	Test Date	2024/8/22
Test Frequency	CH00: 2402 MHz	Polarization	Vertical

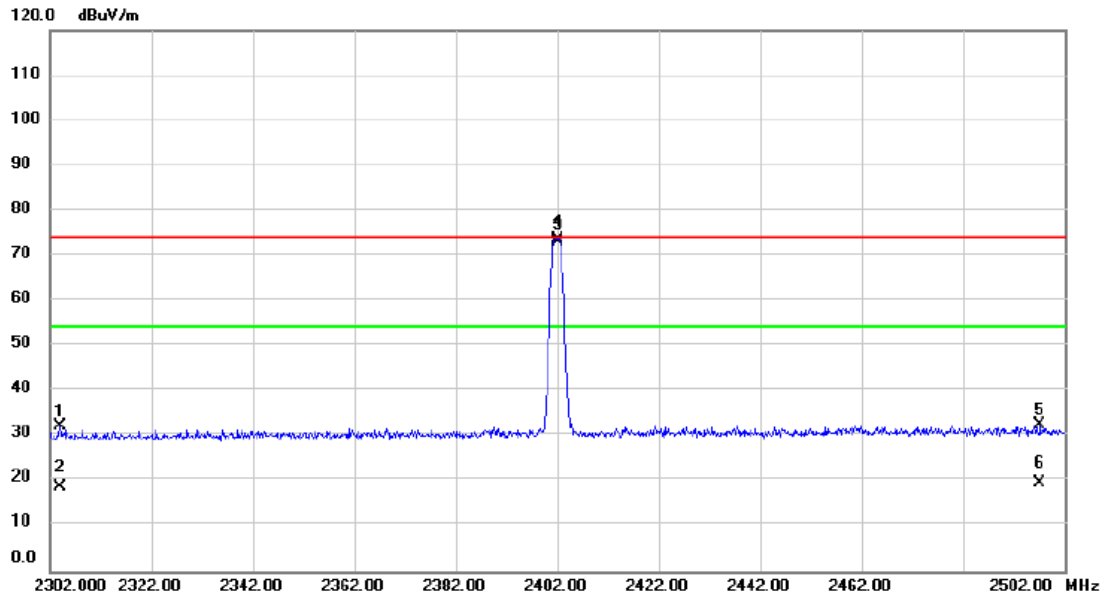

No.	Mk.	Freq. MHz	Reading Level dBuV	Correct Factor dB	Measure- ment dBuV/m	Limit dBuV/m	Margin dB	Detector	Antenna Height cm	Table Degree degree	Comment
1		2304.000	38.54	-6.31	32.23	74.00	-41.77	peak			
2		2304.000	24.97	-6.31	18.66	54.00	-35.34	AVG			
3		2402.200	79.71	-6.09	73.62	74.00	-0.38	peak			No Limit
4	*	2402.200	79.04	-6.09	72.95	54.00	18.95	AVG			No Limit
5		2497.200	38.47	-5.88	32.59	74.00	-41.41	peak			
6		2497.200	25.40	-5.88	19.52	54.00	-34.48	AVG			

**REMARKS:**

- (1) Measurement Value = Reading Level + Correct Factor.
- (2) Margin Level = Measurement Value - Limit Value.

Test Mode	BLE (1 Mbps)	Test Date	2024/8/22
Test Frequency	CH39: 2480 MHz	Polarization	Vertical

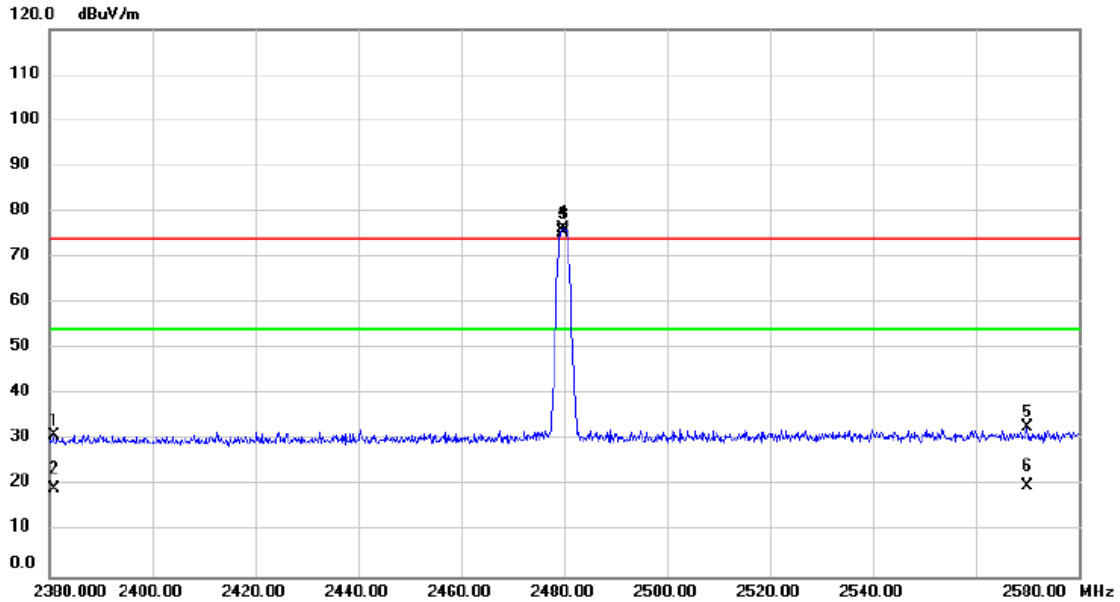

No.	Mk.	Freq. MHz	Reading Level dBuV	Correct Factor dB	Measure- ment dBuV/m	Limit dBuV/m	Margin dB	Detector	Antenna Height cm	Table Degree	Comment
1		2380.800	37.30	-6.13	31.17	74.00	-42.83	peak			
2		2380.800	25.43	-6.13	19.30	54.00	-34.70	AVG			
3	X	2479.800	82.13	-5.92	76.21	74.00	2.21	peak			No Limit
4	*	2479.800	81.48	-5.92	75.56	54.00	21.56	AVG			No Limit
5		2570.000	38.30	-5.60	32.70	74.00	-41.30	peak			
6		2570.000	25.64	-5.60	20.04	54.00	-33.96	AVG			

**REMARKS:**

- (1) Measurement Value = Reading Level + Correct Factor.
- (2) Margin Level = Measurement Value - Limit Value.

Test Mode	BLE (1 Mbps)	Test Date	2024/8/27
Test Frequency	CH00: 2402 MHz	Polarization	Vertical

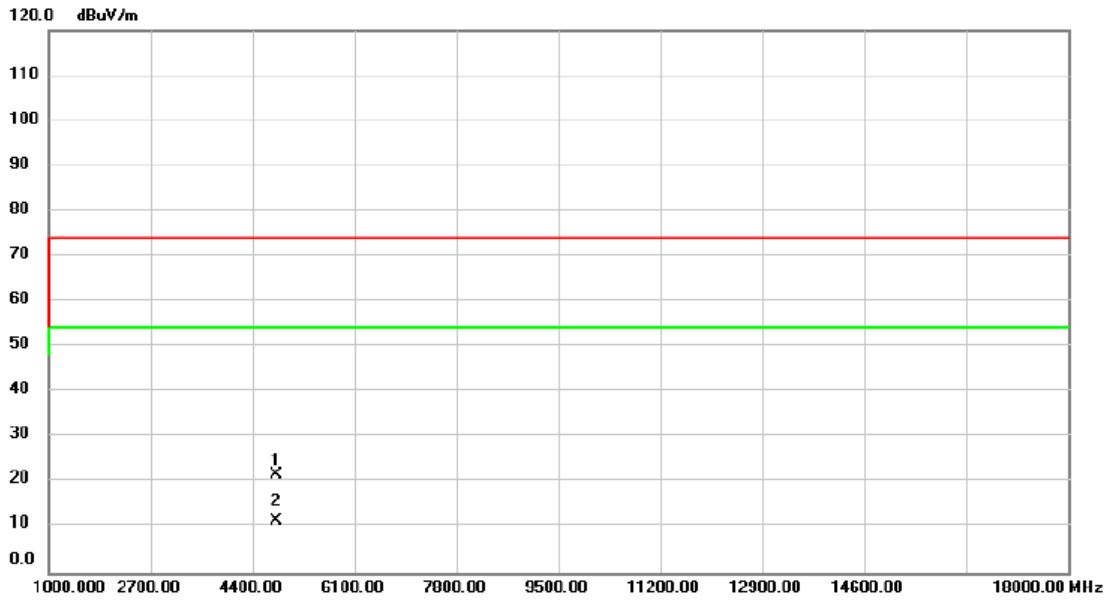

No. Mk.	Freq. MHz	Reading Level dBuV	Correct Factor dB	Measurement dBuV/m	Limit dBuV/m	Margin dB	Detector	Antenna Height cm	Table Degree	Comment
1	4804.000	30.35	-8.62	21.73	74.00	-52.27	peak			
2 *	4804.000	20.30	-8.62	11.68	54.00	-42.32	AVG			

**REMARKS:**

- (1) Measurement Value = Reading Level + Correct Factor.
- (2) Margin Level = Measurement Value - Limit Value.

Test Mode	BLE (1 Mbps)	Test Date	2024/8/27
Test Frequency	CH00: 2402 MHz	Polarization	Horizontal

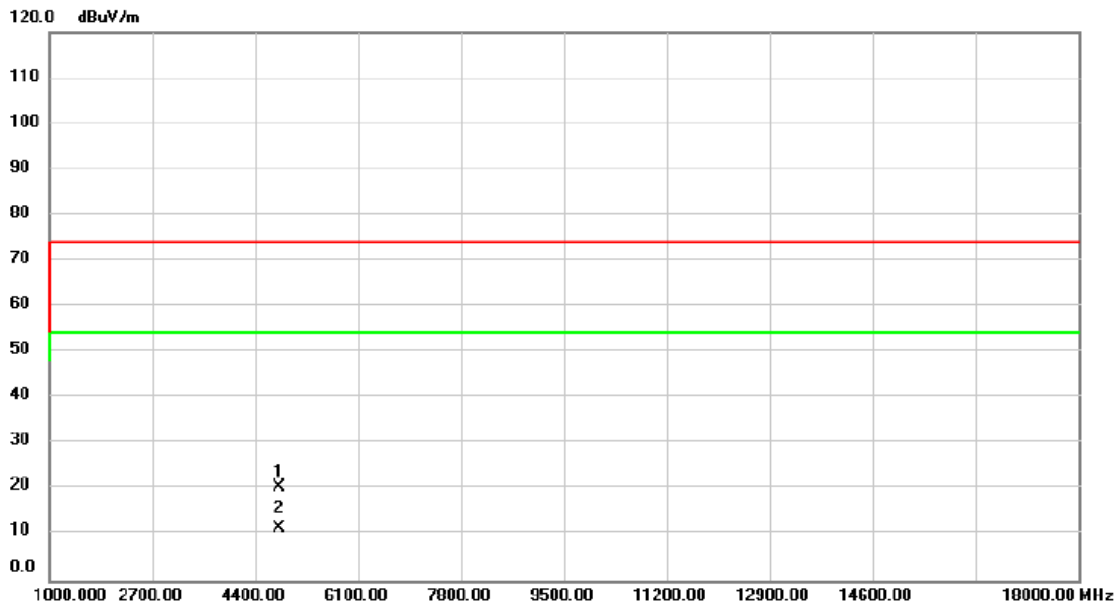

No.	Mk.	Freq. MHz	Reading Level dBuV	Correct Factor dB	Measure- ment dBuV/m	Limit dBuV/m	Margin dB	Detector	Antenna Height cm	Table Degree	Comment
1		4804.000	29.23	-8.62	20.61	74.00	-53.39	peak			
2	*	4804.000	20.18	-8.62	11.56	54.00	-42.44	AVG			

**REMARKS:**

- (1) Measurement Value = Reading Level + Correct Factor.
- (2) Margin Level = Measurement Value - Limit Value.

Test Mode	BLE (1 Mbps)	Test Date	2024/8/27
Test Frequency	CH19: 2440 MHz	Polarization	Vertical

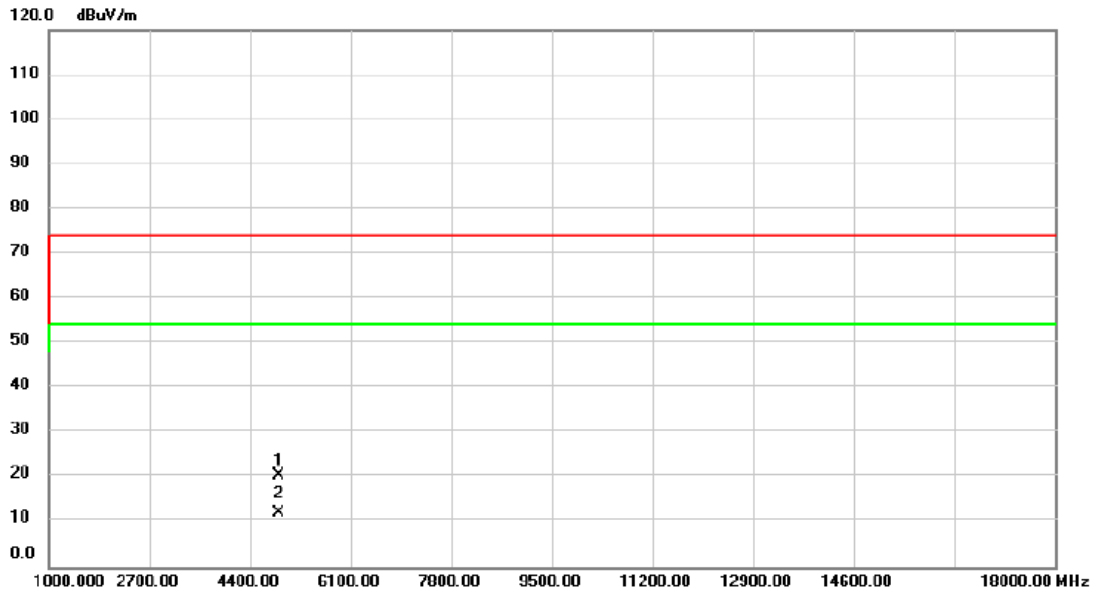

No.	Mk.	Freq. MHz	Reading Level dBuV	Correct Factor dB	Measure- ment dBuV/m	Limit dBuV/m	Margin dB	Detector	Antenna Height cm	Table Degree	Comment
1		4880.000	28.90	-8.43	20.47	74.00	-53.53	peak			
2	*	4880.000	20.59	-8.43	12.16	54.00	-41.84	AVG			

**REMARKS:**

- (1) Measurement Value = Reading Level + Correct Factor.
- (2) Margin Level = Measurement Value - Limit Value.



Test Mode	BLE (1 Mbps)	Test Date	2024/8/27
Test Frequency	CH19: 2440 MHz	Polarization	Horizontal

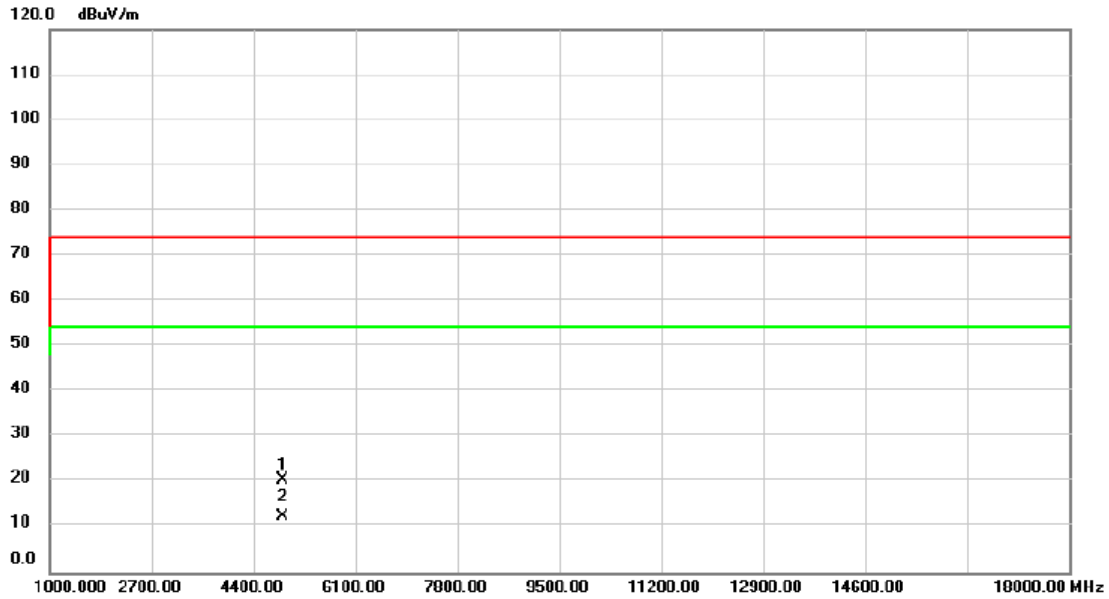

No. Mk.	Freq. MHz	Reading Level dBuV	Correct Factor dB	Measurement dBuV/m	Limit dBuV/m	Margin dB	Detector	Antenna Height cm	Table Degree	Comment
1	4880.000	29.06	-8.43	20.63	74.00	-53.37	peak			
2 *	4880.000	20.99	-8.43	12.56	54.00	-41.44	AVG			

**REMARKS:**

- (1) Measurement Value = Reading Level + Correct Factor.
- (2) Margin Level = Measurement Value - Limit Value.

Test Mode	BLE (1 Mbps)	Test Date	2024/8/27
Test Frequency	CH39: 2480 MHz	Polarization	Vertical

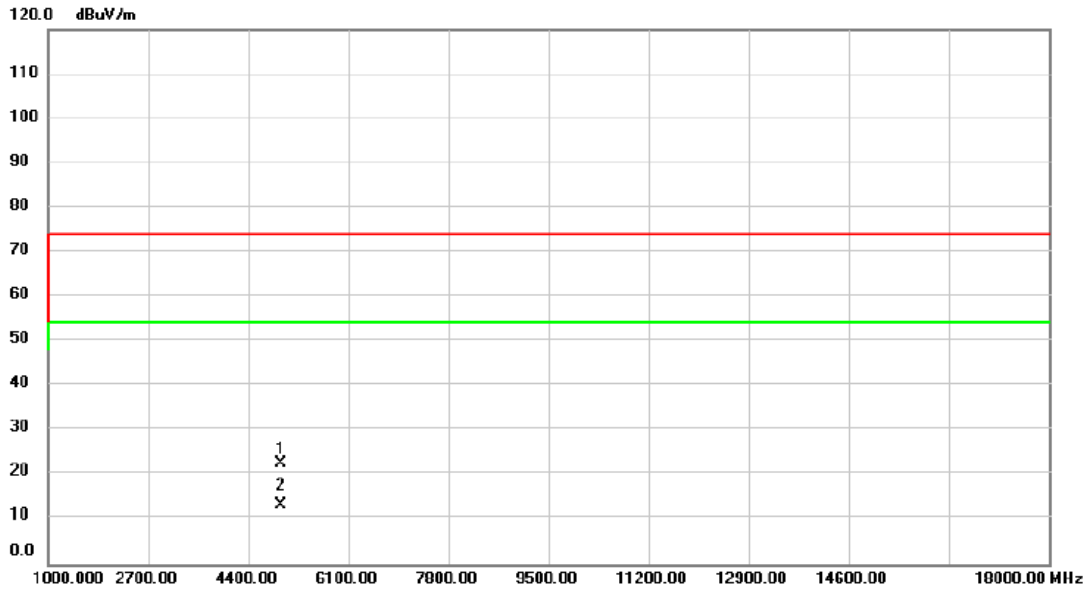

No. Mk.	Freq.	Reading Level	Correct Factor	Measurement	Limit	Margin	Antenna Height	Table Degree	
	MHz	dBuV	dB	dBuV/m	dBuV/m	dB	cm	degree	Comment
1	4960.000	31.02	-8.23	22.79	74.00	-51.21			peak
2 *	4960.000	21.44	-8.23	13.21	54.00	-40.79			AVG

**REMARKS:**

- (1) Measurement Value = Reading Level + Correct Factor.
- (2) Margin Level = Measurement Value - Limit Value.

Test Mode	BLE (1 Mbps)	Test Date	2024/8/27
Test Frequency	CH39: 2480 MHz	Polarization	Horizontal

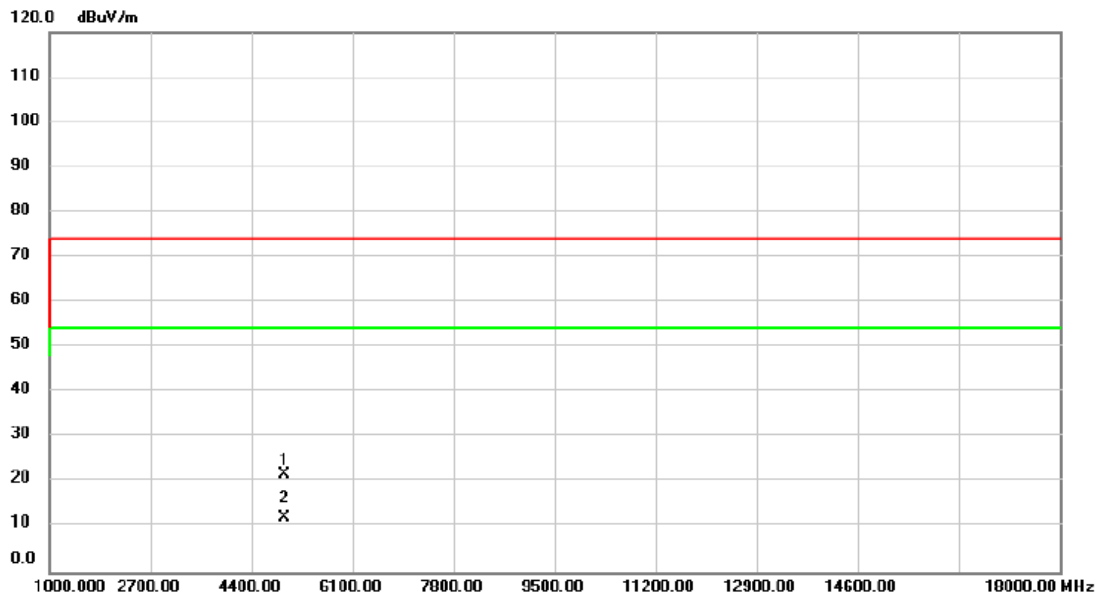

No.	Mk.	Freq. MHz	Reading Level dBuV	Correct Factor dB	Measure- ment dBuV/m	Limit dBuV/m	Margin dB	Detector	Antenna Height cm	Table Degree	Comment
1		4960.000	30.02	-8.23	21.79	74.00	-52.21	peak			
2	*	4960.000	20.49	-8.23	12.26	54.00	-41.74	AVG			

**REMARKS:**

- (1) Measurement Value = Reading Level + Correct Factor.
- (2) Margin Level = Measurement Value - Limit Value.

Test Mode	BLE (1 Mbps)	Test Date	2024/8/27
Test Frequency	CH39: 2480 MHz	Polarization	Vertical

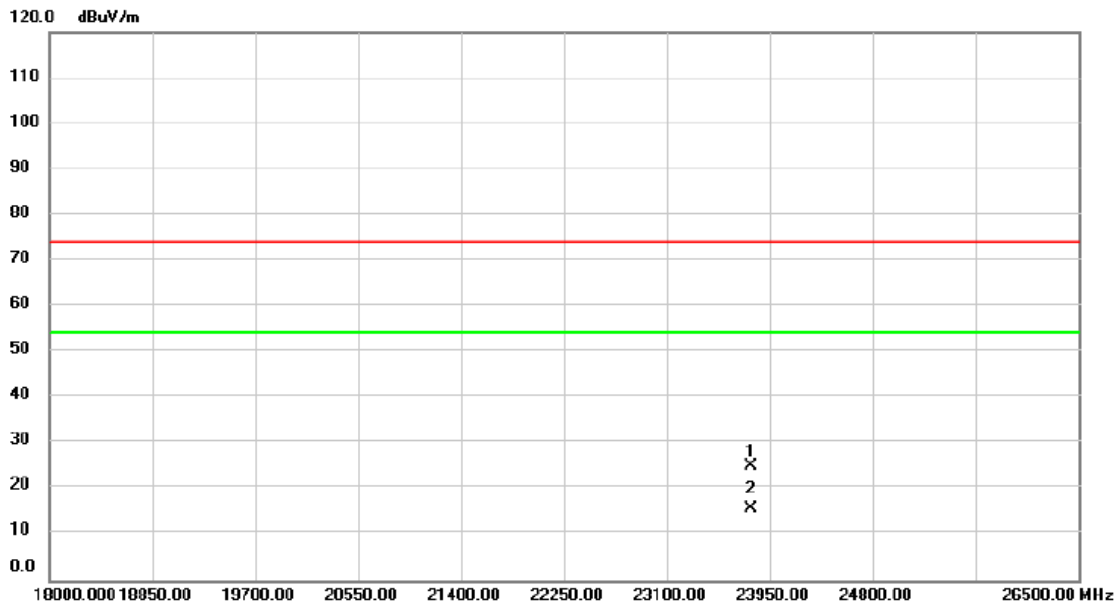

No.	Mk.	Freq.	Reading Level	Correct Factor	Measurement	Limit	Margin	Antenna Height	Table Degree	
		MHz	dBuV	dB	dBuV/m	dBuV/m	dB	cm	degree	Comment
1		23797.00	33.25	-8.19	25.06	74.00	-48.94			peak
2	*	23797.00	23.85	-8.19	15.66	54.00	-38.34			AVG

**REMARKS:**

- (1) Measurement Value = Reading Level + Correct Factor.
- (2) Margin Level = Measurement Value - Limit Value.

Test Mode	BLE (1 Mbps)	Test Date	2024/8/27
Test Frequency	CH39: 2480 MHz	Polarization	Horizontal

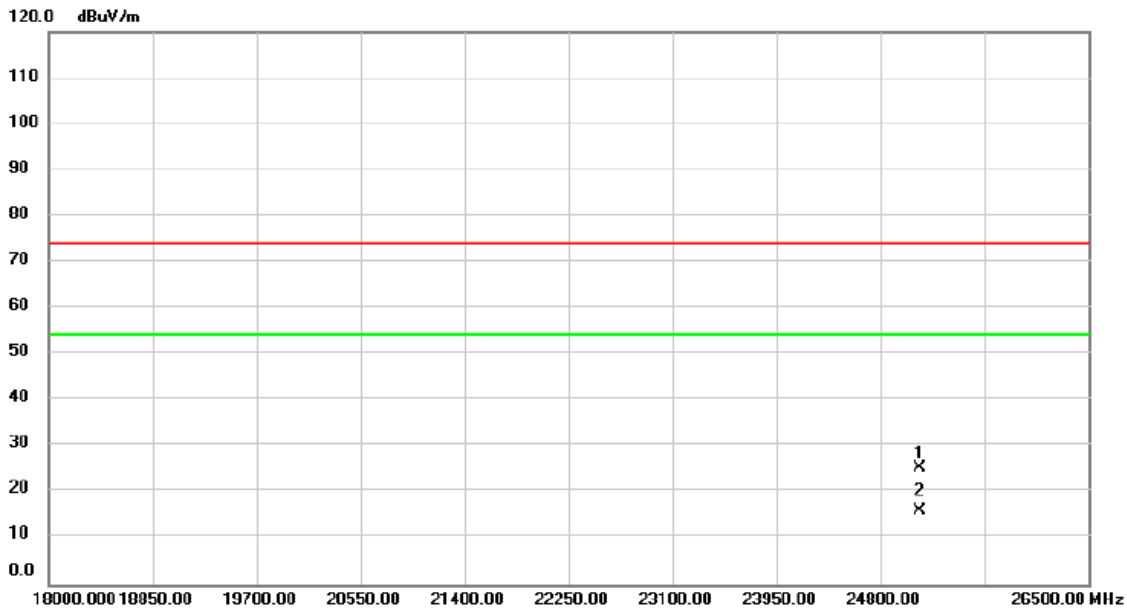

No.	Mk.	Freq.	Reading Level	Correct Factor	Measurement	Limit	Margin	Antenna Height	Table Degree	Comment
		MHz	dBuV	dB	dBuV/m	dBuV/m	dB	cm	degree	
1		25123.00	33.16	-7.93	25.23	74.00	-48.77	peak		
2	*	25123.00	23.88	-7.93	15.95	54.00	-38.05	AVG		

**REMARKS:**

- (1) Measurement Value = Reading Level + Correct Factor.
- (2) Margin Level = Measurement Value - Limit Value.

## APPENDIX D BANDWIDTH

Test Mode: 1Mbps

Frequency (MHz)	6 dB Bandwidth (MHz)	99 % Occupied Bandwidth (MHz)	Min. Limit (kHz)	Test Result
2402	0.734	1.044	500	Pass
2440	0.724	1.056	500	Pass
2480	0.730	1.044	500	Pass

CH00

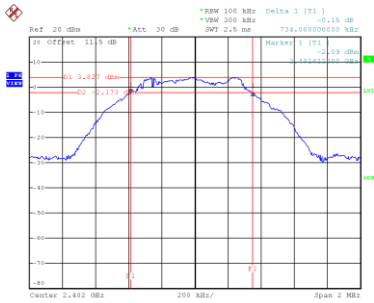

Date: 8.AUG.2024 22:28:18

CH19  
6 dB Bandwidth

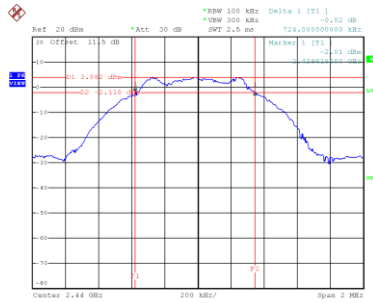

Date: 8.AUG.2024 22:30:07

CH39

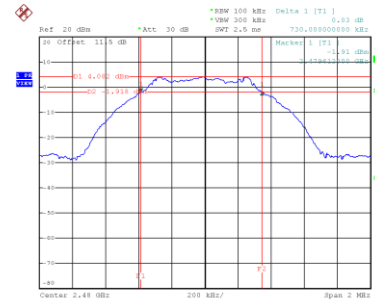

Date: 8.AUG.2024 22:32:07

99 % Occupied Bandwidth

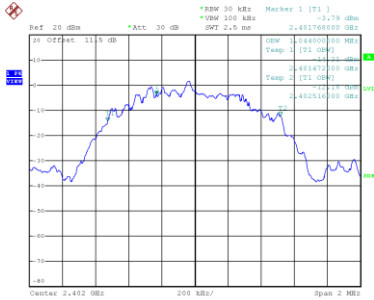

Date: 8.AUG.2024 22:27:48

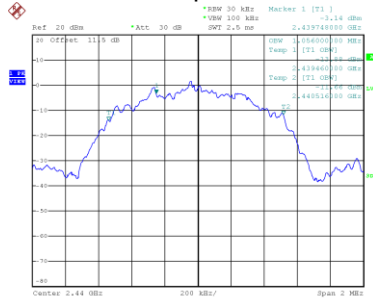

Date: 8.AUG.2024 22:30:15

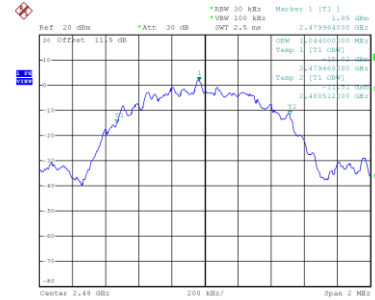

Date: 8.AUG.2024 22:32:15

## APPENDIX E    MAXIMUM OUTPUT POWER



Test Mode :	1Mbps	Tested Date	2024/8/08
-------------	-------	-------------	-----------

Frequency (MHz)	Conducted Power (dBm)	Conducted Power (W)	Max. Limit (dBm)	Max. Limit (W)	Test Result
2402	4.82	0.0030	30.00	1.0000	Pass
2440	4.83	0.0030	30.00	1.0000	Pass
2480	5.02	0.0032	30.00	1.0000	Pass

## APPENDIX F POWER SPECTRAL DENSITY TEST

Test Mode : 1Mbps

Frequency (MHz)	Power Density (dBm/3kHz)	Max. Limit (dBm/3kHz)	Test Result
2402	-10.10	8.00	Pass
2440	-10.19	8.00	Pass
2480	-10.70	8.00	Pass

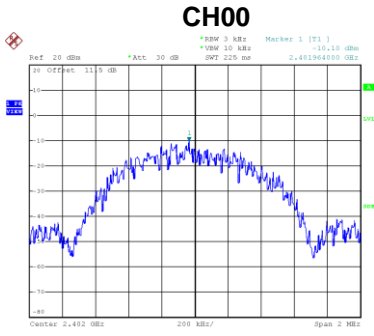

Date: 6.AUG.2024 22:29:08

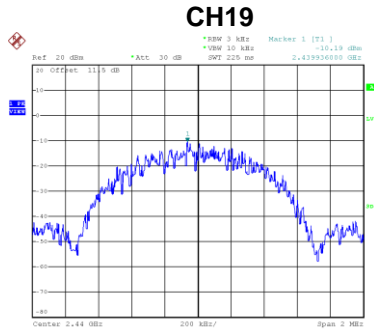

Date: 6.AUG.2024 22:31:05

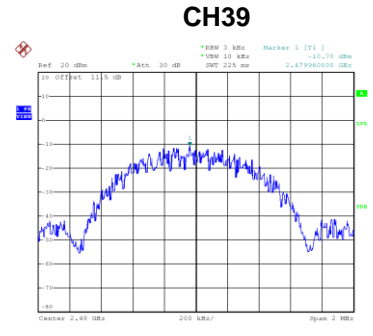

Date: 6.AUG.2024 22:33:05

## **APPENDIX G ANTENNA CONDUCTED SPURIOUS EMISSION**

Test Mode : 1Mbps

### Bandedge CH00 (Lower)

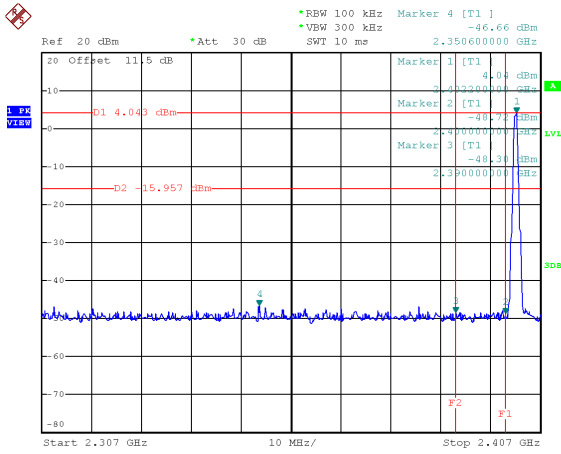

### Bandedge CH39 (Upper)

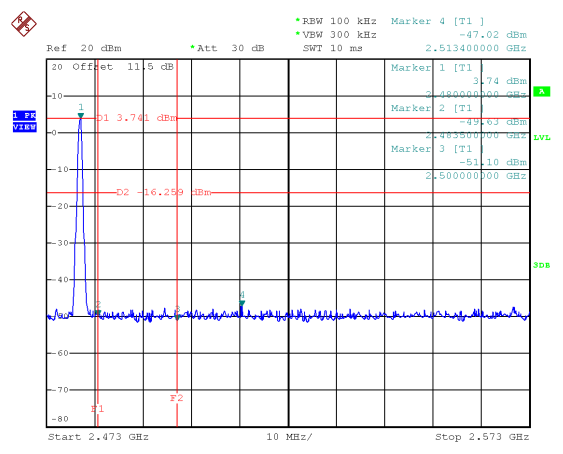

Date: 8.AUG.2024 22:28:27

Date: 8.AUG.2024 22:32:24

### CH00 – 10th Harmonic of the fundamental frequency

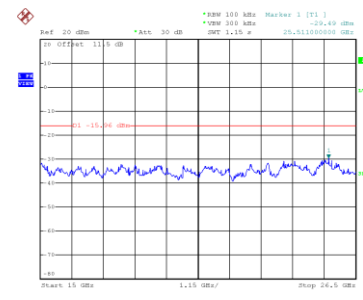
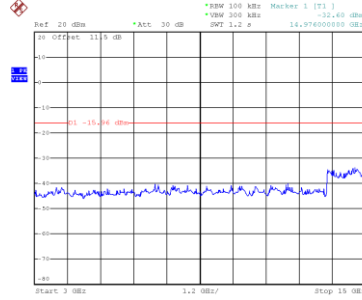
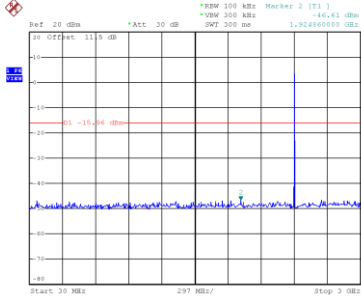

Date: 8.AUG.2024 22:28:42

Date: 8.AUG.2024 22:28:51

Date: 8.AUG.2024 22:29:00

### CH19 – 10th Harmonic of the fundamental frequency

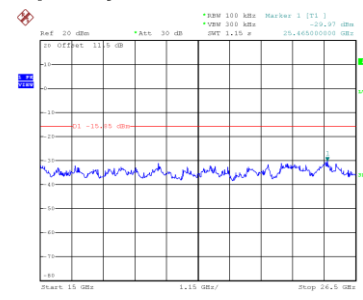
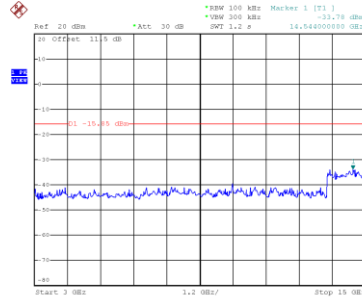
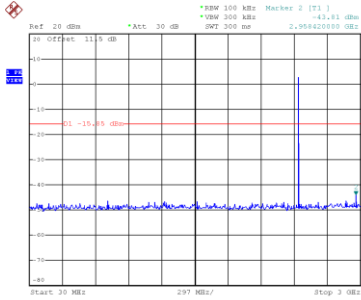

Date: 8.AUG.2024 22:30:19

Date: 8.AUG.2024 22:30:48

Date: 8.AUG.2024 22:30:57

### CH39 – 10th Harmonic of the fundamental frequency

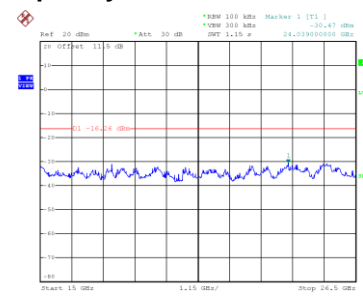
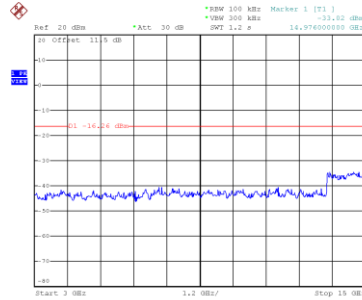
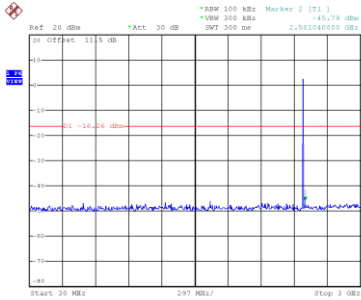

Date: 8.AUG.2024 22:32:19

Date: 8.AUG.2024 22:32:48

Date: 8.AUG.2024 22:32:57

End of Test Report