



# FCC TEST REPORT (Z-WAVE)

**REPORT NO.:** RF140924C03-1  
**MODEL NO.:** DCH-G020, DCH-G020X  
**FCC ID:** KA2CHG020A1  
**RECEIVED:** Sep. 24, 2014  
**TESTED:** Oct. 20 ~ Oct. 23, 2014  
**ISSUED:** Oct. 29, 2014

**APPLICANT :** D-LINK CORPORATION

**ADDRESS :** 17595 Mt. Hermann, Fountain Valley, CA 92708,  
U.S.A

**ISSUED BY:** Bureau Veritas Consumer Products Services  
(H.K.) Ltd., Taoyuan Branch

**LAB ADDRESS:** No. 47-2, 14th Ling, Chia Pau Vil., Lin Kou Dist.,  
New Taipei City, Taiwan ( R.O.C. )

**TEST LOCATION:** No. 19, Hwa Ya 2nd Rd, Wen Hwa Tsuen, Kwei  
Shan Hsiang, Taoyuan Hsien 333, Taiwan, R.O.C.

This report should not be used by the client to claim product certification, approval, or endorsement by TAF or any government agencies.



This report is for your exclusive use. Any copying or replication of this report to or for any other person or entity, or use of our name or trademark, is permitted only with our prior written permission. This report sets forth our findings solely with respect to the test samples identified herein. The results set forth in this report are not indicative or representative of the quality or characteristics of the lot from which a test sample was taken or any similar or identical product unless specifically and expressly noted. Our report includes all of the tests requested by you and the results thereof based upon the information that you provided to us. You have 60 days from date of issuance of this report to notify us of any material error or omission caused by our negligence, provided, however, that such notice shall be in writing and shall specifically address the issue you wish to raise. A failure to raise such issue within the prescribed time shall constitute your unqualified acceptance of the completeness of this report, the tests conducted and the correctness of the report contents. Unless specific mention, the uncertainty of measurement has been explicitly taken into account to declare the compliance or non-compliance to the specification.

## Table of Contents

RELEASE CONTROL RECORD .....	3
1. CERTIFICATION .....	4
2. SUMMARY OF TEST RESULTS .....	5
2.1 MEASUREMENT UNCERTAINTY .....	5
3. GENERAL INFORMATION.....	6
3.1 GENERAL DESCRIPTION OF EUT.....	6
3.2 DESCRIPTION OF TEST MODES.....	7
3.2.1 TEST MODE APPLICABILITY AND TESTED CHANNEL DETAIL .....	8
3.3 DESCRIPTION OF SUPPORT UNITS .....	10
3.3.1 CONFIGURATION OF SYSTEM UNDER TEST .....	10
3.4 GENERAL DESCRIPTION OF APPLIED STANDARDS .....	10
4. TEST TYPES AND RESULTS .....	11
4.1 RADIATED EMISSION AND BAND EDGE MEASUREMENT.....	11
4.1.1 LIMITS OF RADIATED EMISSION MEASUREMENT.....	11
4.1.2 TEST INSTRUMENTS .....	12
4.1.3 TEST PROCEDURES .....	13
4.1.4 DEVIATION FROM TEST STANDARD .....	13
4.1.5 TEST SETUP .....	14
4.1.6 EUT OPERATING CONDITIONS .....	14
4.1.7 TEST RESULTS .....	15
4.2 CONDUCTED EMISSION MEASUREMENT .....	24
4.2.1 LIMITS OF CONDUCTED EMISSION MEASUREMENT.....	24
4.2.2 TEST INSTRUMENTS .....	24
4.2.3 TEST PROCEDURES .....	25
4.2.4 DEVIATION FROM TEST STANDARD .....	25
4.2.5 TEST SETUP .....	26
4.2.6 EUT OPERATING CONDITIONS .....	26
4.2.7 TEST RESULTS .....	27
5. PHOTOGRAPHS OF THE TEST CONFIGURATION.....	33
6. INFORMATION ON THE TESTING LABORATORIES .....	34
7. APPENDIX A - MODIFICATIONS RECORDERS FOR ENGINEERING CHANGES TO THE EUT BY THE LAB.....	35



A D T

## RELEASE CONTROL RECORD

ISSUE NO.	REASON FOR CHANGE	DATE ISSUED
RF140924C03-1	Original release	Oct. 29, 2014

## 1. CERTIFICATION

**PRODUCT:** mydlink™ Connected Home Hub, Smart home hub

**MODEL NO.:** DCH-G020, DCH-G020X

**BRAND:** D-Link

**APPLICANT:** D-LINK CORPORATION

**TESTED:** Oct. 20 ~ Oct. 23, 2014

**TEST SAMPLE:** ENGINEERING SAMPLE

**STANDARDS:** FCC Part 15, Subpart C (Section 15.249)

The above equipment (model: DCH-G020) have been tested by **Bureau Veritas Consumer Products Services (H.K.) Ltd., Taoyuan Branch**, and found compliance with the requirement of the above standards. The test record, data evaluation & Equipment Under Test (EUT) configurations represented herein are true and accurate accounts of the measurements of the sample's EMC characteristics under the conditions specified in this report.

**PREPARED BY** : Celine Chou , **DATE:** Oct. 29, 2014  
Celine Chou / Specialist

**APPROVED BY** : Ken Liu , **DATE:** Oct. 29, 2014  
Ken Liu / Senior Manager

## 2. SUMMARY OF TEST RESULTS

The EUT has been tested according to the following specifications:

APPLIED STANDARD: FCC Part 15, Subpart C (Section 15.249)			
STANDARD PARAGRAPH	TEST TYPE	RESULT	REMARK
15.207	Conducted Emission Test	PASS	Meet the requirement of limit. Minimum passing margin is -15.69dB at 0.16967MHz.
15.209 15.249 15.249 (d)	Radiated Emission Test Band Edge Measurement Limit: 50dB less than the peak value of fundamental frequency or meet radiated emission limit in section 15.209	PASS	Meet the requirement of limit. Minimum passing margin is -1.1dB at 908.42MHz.

### 2.1 MEASUREMENT UNCERTAINTY

Where relevant, the following measurement uncertainty levels have been estimated for tests performed on the EUT as specified in CISPR 16-4-2:

MEASUREMENT	FREQUENCY	UNCERTAINTY
Conducted emissions	9kHz~30MHz	2.44 dB
Radiated emissions	30MHz ~ 200MHz	3.59 dB
	200MHz ~1000MHz	3.60 dB
	1GHz ~ 18GHz	2.29 dB
	18GHz ~ 40GHz	2.29 dB

This uncertainty represents an expanded uncertainty expressed at approximately the 95% confidence level using a coverage factor of k=2.

### 3. GENERAL INFORMATION

#### 3.1 GENERAL DESCRIPTION OF EUT

<b>EUT</b>	mydlink™ Connected Home Hub, Smart home hub
<b>MODEL NO.</b>	DCH-G020, DCH-G020X
<b>POWER SUPPLY</b>	5Vdc from adapter
<b>MODULATION TYPE</b>	2 Frequency Shift Keying (2FSK) (9.6kbpps) 2 Gaussian Frequency Shift Keying (2GFSK) (40kbps/100kbps)
<b>DATA RATE</b>	9.6kbps, 40kbps, 100kbps
<b>OPERATING FREQUENCY</b>	908.42MHz, 908.4MHz, 916MHz
<b>NUMBER OF CHANNEL</b>	3
<b>ANTENNA TYPE</b>	Patch antenna with 2dBi gain
<b>DATA CABLE</b>	NA
<b>I/O PORT</b>	Refer to User's Manual
<b>ACCESSORY DEVICES</b>	Adapter

**NOTE:**

1. All models are listed as below..

Brand	Model	Product	Difference
D-Link	DCH-G020 (Main test model)	mydlink™ Connected Home Hub	with black base
	DCH-G020X	Smart home hub	with gray base

2. The EUT consumes power from the following adapter.

Adapter 1	
<b>Brand</b>	Ktec
<b>Model</b>	KSAS0120500200D5
<b>Input Power</b>	100-240Vac, 50/60Hz, 0.4A
<b>Output Power</b>	5Vdc, 2A
<b>Power Line</b>	DC1.25m power cable without core attached on adapter

Adapter 2	
<b>Brand</b>	DVE
<b>Model</b>	DSA-12CA-05 050200
<b>Input Power</b>	100-240Vac, 50/60Hz, 0.3A
<b>Output Power</b>	5Vdc, 2A
<b>Power Line</b>	DC1.2m power cable without core attached on adapter

\* After pre-tested, adapter 2 was chosen for final test and presented in the test report.

3. The above EUT information is declared by manufacturer and for more detailed features description, please refer to the manufacturer's specifications or user's manual.



A D T

### 3.2 DESCRIPTION OF TEST MODES

3 channels are provided to this EUT.

CHANNEL	FREQ. (MHz)
1	908.42
2	908.40
3	916.00

### 3.2.1 TEST MODE APPLICABILITY AND TESTED CHANNEL DETAIL

EUT CONFIGURE MODE	APPLICABLE TO				DESCRIPTION
	RE $\geq$ 1G	RE<1G	PLC	BM	
-	√	√	√	√	

Where **RE<1G**: Radiated Emission below 1GHz      **RE $\geq$ 1G**: Radiated Emission above 1GHz  
**PLC**: Power Line Conducted Emission      **BM**: Bandedge Measurement

**NOTE:** The EUT had been pre-tested on the positioned of each 3 axis. The worst case was found when positioned on Z-plane

#### RADIATED EMISSION TEST (ABOVE 1 GHz):

- Pre-Scan has been conducted to determine the worst-case mode from all possible combinations between available modulations and antenna ports (if EUT with antenna diversity architecture).
- Following channel(s) was (were) selected for the final test as listed below.

TESTED CHANNEL	OPERATING FREQUENCY	MODULATION TYPE
1	908.42MHz	2FSK
2	908.40MHz	2GFSK
3	916.00MHz	2GFSK

#### RADIATED EMISSION TEST (BELOW 1 GHz):

- Pre-Scan has been conducted to determine the worst-case mode from all possible combinations between available modulations and antenna ports (if EUT with antenna diversity architecture).
- Following channel(s) was (were) selected for the final test as listed below.

TESTED CHANNEL	OPERATING FREQUENCY	MODULATION TYPE
1	908.42MHz	2FSK
2	908.40MHz	2GFSK
3	916.00MHz	2GFSK

#### POWER LINE CONDUCTED EMISSION TEST:

- Pre-Scan has been conducted to determine the worst-case mode from all possible combinations between available modulations and antenna ports (if EUT with antenna diversity architecture).
- Following channel(s) was (were) selected for the final test as listed below.

TESTED CHANNEL	OPERATING FREQUENCY	MODULATION TYPE
1	908.42MHz	2FSK
2	908.40MHz	2GFSK
3	916.00MHz	2GFSK





**BANDEDGE MEASUREMENT:**

- Pre-Scan has been conducted to determine the worst-case mode from all possible combinations between available modulations and antenna ports (if EUT with antenna diversity architecture).
- Following channel(s) was (were) selected for the final test as listed below.

TESTED CHANNEL	OPERATING FREQUENCY	MODULATION TYPE
1	908.42MHz	2FSK
2	908.40MHz	2GFSK
3	916.00MHz	2GFSK

**TEST CONDITION:**

APPLICABLE TO	ENVIRONMENTAL CONDITIONS	INPUT POWER	TESTED BY
RE $\geq$ 1G	23deg. C, 71%RH	120Vac, 60Hz	Alan Wu
RE $<$ 1G	23deg. C, 71%RH	120Vac, 60Hz	Alan Wu
PLC	22deg. C, 72%RH	120Vac, 60Hz	Nick Hsu
BM	24deg. C, 64%RH	120Vac, 60Hz	Match Tsui

### 3.3 DESCRIPTION OF SUPPORT UNITS

The EUT has been tested as an independent unit.

#### 3.3.1 CONFIGURATION OF SYSTEM UNDER TEST

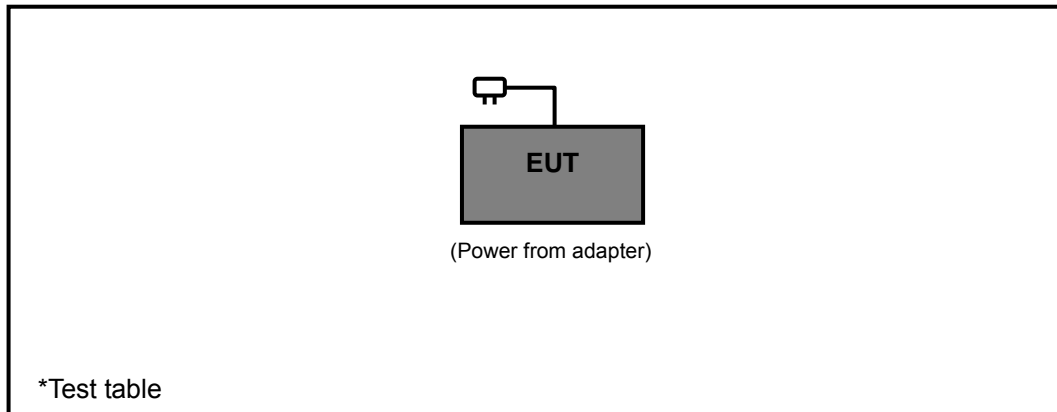

### 3.4 GENERAL DESCRIPTION OF APPLIED STANDARDS

The EUT is a RF Product. According to the specifications of the manufacturer, it must comply with the requirements of the following standards:

#### **FCC Part 15, Subpart C (Section 15.249)**

ANSI C63.10-2009

All test items have been performed and recorded as per the above standards.

**NOTE:** The EUT is also considered as a kind of computer peripheral, because the connection to computer is necessary for typical use. It has been verified to comply with the requirements of FCC Part 15, Subpart B, Class B (DoC). The test report has been issued separately.

## 4. TEST TYPES AND RESULTS

### 4.1 RADIATED EMISSION AND BAND EDGE MEASUREMENT

#### 4.1.1 LIMITS OF RADIATED EMISSION MEASUREMENT

The field strength of emissions from intentional radiators operated within these frequency bands shall comply with the following

Fundamental Frequency	Field Strength of Fundamental (millivolts/meter)	Field Strength of Harmonics (microvolts/meter)
902 ~ 928 MHz	50	500
2400 ~ 2483.5 MHz	50	500
5725 ~ 5875 MHz	50	500
24 ~ 24.25 GHz	250	2500

Emissions radiated outside of the specified frequency bands, except for harmonics, shall be attenuated by at least 50 dB below the level of the fundamental or to the general radiated emission limits as below table, whichever is the lesser attenuation

Frequencies (MHz)	Field strength (microvolts/meter)	Measurement distance (meters)
0.009 ~ 0.490	2400/F(kHz)	300
0.490 ~ 1.705	24000/F(kHz)	30
1.705 ~ 30.0	30	30
30 ~ 88	100	3
88 ~ 216	150	3
216 ~ 960	200	3
Above 960	500	3

**NOTE:**

1. The lower limit shall apply at the transition frequencies.
2. Emission level (dBuV/m) = 20 log Emission level (uV/m).
3. For frequencies above 1000MHz, the field strength limits are based on average detector, however, the peak field strength of any emission shall not exceed the maximum permitted average limits, specified above by more than 20dB under any condition of modulation.

#### 4.1.2 TEST INSTRUMENTS

DESCRIPTION & MANUFACTURER	MODEL NO.	SERIAL NO.	DATE OF CALIBRATION	DUE DATE OF CALIBRATION
Test Receiver ROHDE & SCHWARZ	ESCI	100424	Oct. 06, 2014	Oct. 05, 2015
Spectrum Analyzer ROHDE & SCHWARZ	FSU 43	100115	Dec. 18, 2013	Dec. 17, 2014
BILOG Antenna SCHWARZBECK	VULB9168	9168-155	Feb. 26, 2014	Feb. 25, 2015
HORN Antenna SCHWARZBECK	BBHA 9120D	9120D-404	Jan. 05, 2014	Jan. 04, 2015
HORN Antenna SCHWARZBECK	BBHA 9170	BBHA9170241	Feb. 17, 2014	Feb. 16, 2015
Preamplifier Agilent	8449B	3008A01961	Oct. 18, 2014	Oct. 17, 2015
Preamplifier Agilent	8447D	2944A10738	Oct. 18, 2014	Oct. 17, 2015
RF signal cable HUBER+SUHNNER	SUCOFLEX 104	309220/4	Aug. 09, 2014	Aug. 08, 2015
RF signal cable HUBER+SUHNNER	SUCOFLEX 104	250724/4	Aug. 09, 2014	Aug. 08, 2015
RF signal cable HUBER+SUHNNER	SUCOFLEX 104	295012/4	Aug. 09, 2014	Aug. 08, 2015
Software BV ADT	ADT_Radiated_ V7.6.15.9.4	NA	NA	NA
Antenna Tower inn-co GmbH	MA 4000	010303	NA	NA
Antenna Tower Controller inn-co GmbH	CO2000	019303	NA	NA
Turn Table BV ADT	TT100.	TT93021704	NA	NA
Turn Table Controller BV ADT	SC100.	SC93021704	NA	NA

- NOTE:**
1. The calibration interval of the above test instruments is 12 months and the calibrations are traceable to NML/ROC and NIST/USA.
  2. The test was performed in HwaYa Chamber 4.
  3. The horn antenna and HP preamplifier (model: 8449B) are used only for the measurement of emission frequency above 1GHz if tested.
  4. The FCC Site Registration No. is 460141.
  5. The IC Site Registration No. is IC7450F-4.

#### 4.1.3 TEST PROCEDURES

- a. The EUT was placed on the top of a rotating table 0.8 meters above the ground at a 3 meter semi-anechoic chamber. The table was rotated 360 degrees to determine the position of the highest radiation.
- b. The EUT was set 3 meters away from the interference-receiving antenna, which was mounted on the top of a variable-height antenna tower.
- c. The antenna is a broadband antenna, and its height is varied from one meter to four meters above the ground to determine the maximum value of the field strength. Both horizontal and vertical polarizations of the antenna are set to make the measurement.
- d. For each suspected emission, the EUT was arranged to its worst case and then the antenna was tuned to heights from 1 meter to 4 meters and the rotatable table was turned from 0 degrees to 360 degrees to find the maximum reading.
- e. The test-receiver system was set to Peak Detect Function and Specified Bandwidth with Maximum Hold Mode.
- f. If the emission level of the EUT in peak mode was lower than the limit specified, then testing could be stopped and the peak values of the EUT would be reported. Otherwise the emissions would be re-tested one by one using peak, quasi-peak or average method as specified and then reported in a data sheet.

**NOTE:**

1. The resolution bandwidth and video bandwidth of test receiver/spectrum analyzer is 120kHz for Quasi-peak detection at frequency below 1GHz.
2. The resolution bandwidth of test receiver/spectrum analyzer is 1MHz and video bandwidth is 3MHz for Peak detection at frequency above 1GHz.
3. All modes of operation were investigated and the worst-case emissions are reported.

#### 4.1.4 DEVIATION FROM TEST STANDARD

No deviation.

### 4.1.5 TEST SETUP

#### Frequency range 30MHz~1GHz

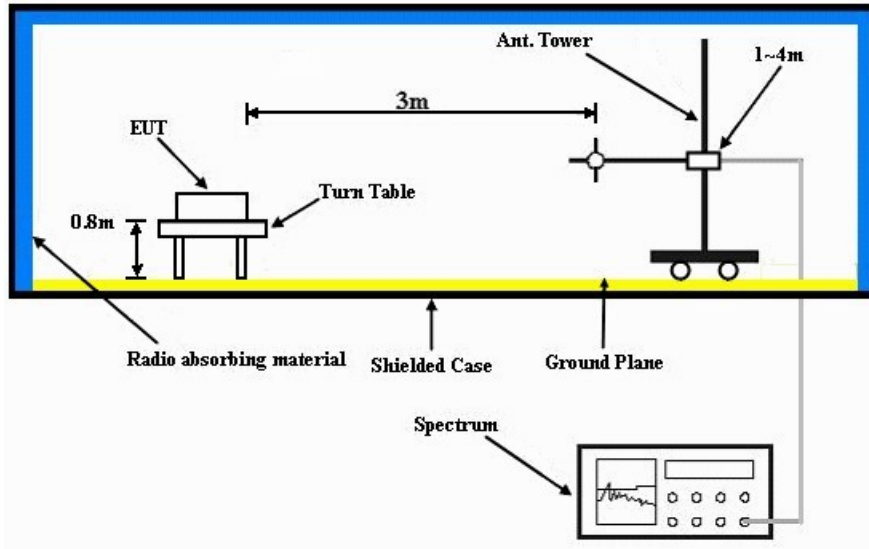

#### Frequency range above 1GHz

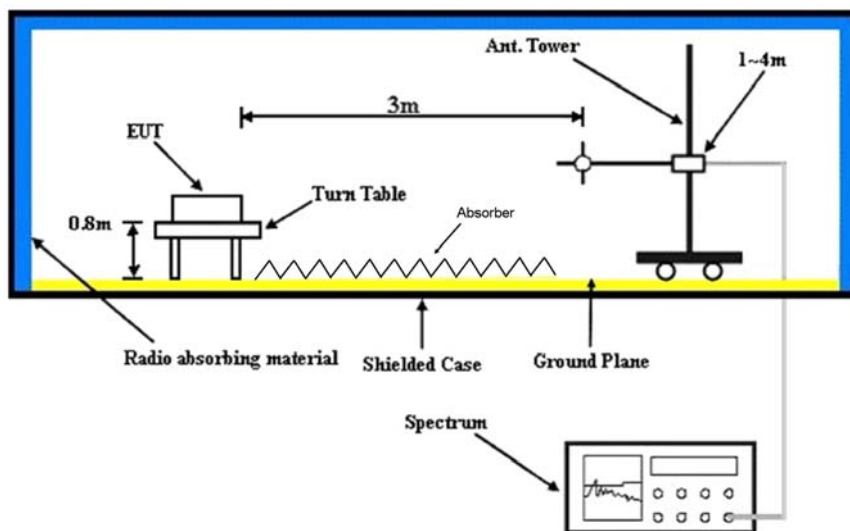

### 4.1.6 EUT OPERATING CONDITIONS

Set the EUT under transmission condition continuously at specific channel frequency.

#### 4.1.7 TEST RESULTS

##### FOR Z-Wave

EUT TEST CONDITION		MEASUREMENT DETAIL	
CHANNEL	Channel 1 (908.42MHz)	FREQUENCY RANGE	Below 1000MHz
INPUT POWER	120Vac, 60 Hz	DETECTOR FUNCTION	Peak (PK) Average (AV)
ENVIRONMENTAL CONDITIONS	23deg. C, 71%RH	TESTED BY	Alan Wu

ANTENNA POLARITY & TEST DISTANCE: HORIZONTAL AT 3 M								
NO.	FREQ. (MHz)	EMISSION LEVEL (dBuV/m)	LIMIT (dBuV/m)	MARGIN (dB)	ANTENNA HEIGHT (m)	TABLE ANGLE (Degree)	RAW VALUE (dBuV)	CORRECTION FACTOR (dB/m)
1	902.00	32.4 QP	46.0	-13.6	1.46 H	40	6.00	26.40
2	*908.42	90.6 PK	114.0	-23.4	1.46 H	40	64.10	26.50
3	*908.42	89.9 AV	94.0	-4.1	1.46 H	40	63.40	26.50
ANTENNA POLARITY & TEST DISTANCE: VERTICAL AT 3 M								
NO.	FREQ. (MHz)	EMISSION LEVEL (dBuV/m)	LIMIT (dBuV/m)	MARGIN (dB)	ANTENNA HEIGHT (m)	TABLE ANGLE (Degree)	RAW VALUE (dBuV)	CORRECTION FACTOR (dB/m)
1	902.00	33.2 QP	46.0	-12.8	1.08 V	66	6.80	26.40
2	*908.42	94.0 PK	114.0	-20.0	1.08 V	66	67.50	26.50
3	*908.42	92.9 AV	94.0	-1.1	1.08 V	66	66.40	26.50

- REMARKS:**
1. Emission level (dBuV/m) = Raw Value (dBuV) + Correction Factor (dB/m).
  2. Correction Factor (dB/m) = Antenna Factor (dB/m) + Cable Factor (dB).  
– Pre-Amplifier Factor(dB)
  3. The other emission levels were very low against the limit.
  4. Margin value = Emission level – Limit value.
  5. “ \* “ : Fundamental frequency



A D T

EUT TEST CONDITION		MEASUREMENT DETAIL	
CHANNEL	Channel 2 (908.40MHz)	FREQUENCY RANGE	Below 1000MHz
INPUT POWER	120Vac, 60 Hz	DETECTOR FUNCTION	Peak (PK) Average (AV)
ENVIRONMENTAL CONDITIONS	23deg. C, 71%RH	TESTED BY	Alan Wu

ANTENNA POLARITY & TEST DISTANCE: HORIZONTAL AT 3 M								
NO.	FREQ. (MHz)	EMISSION LEVEL (dBuV/m)	LIMIT (dBuV/m)	MARGIN (dB)	ANTENNA HEIGHT (m)	TABLE ANGLE (Degree)	RAW VALUE (dBuV)	CORRECTION FACTOR (dB/m)
1	902.00	32.8 QP	46.0	-13.2	1.50 H	62	6.40	26.40
2	*908.40	91.4 PK	114.0	-22.6	1.50 H	62	64.90	26.50
3	*908.40	90.6 AV	94.0	-3.4	1.50 H	62	64.10	26.50
ANTENNA POLARITY & TEST DISTANCE: VERTICAL AT 3 M								
NO.	FREQ. (MHz)	EMISSION LEVEL (dBuV/m)	LIMIT (dBuV/m)	MARGIN (dB)	ANTENNA HEIGHT (m)	TABLE ANGLE (Degree)	RAW VALUE (dBuV)	CORRECTION FACTOR (dB/m)
1	902.00	33.5 QP	46.0	-12.5	1.12 V	70	7.10	26.40
2	*908.40	93.9 PK	114.0	-20.1	1.12 V	70	67.40	26.50
3	*908.40	92.7 AV	94.0	-1.3	1.12 V	70	66.20	26.50

- REMARKS:**
1. Emission level (dBuV/m) = Raw Value (dBuV) + Correction Factor (dB/m).
  2. Correction Factor (dB/m) = Antenna Factor (dB/m) + Cable Factor (dB).  
– Pre-Amplifier Factor(dB)
  3. The other emission levels were very low against the limit.
  4. Margin value = Emission level – Limit value.
  5. “ \* “ : Fundamental frequency



EUT TEST CONDITION		MEASUREMENT DETAIL	
CHANNEL	Channel 3 (916.00MHz)	FREQUENCY RANGE	Below 1000MHz
INPUT POWER	120Vac, 60 Hz	DETECTOR FUNCTION	Peak (PK) Average (AV)
ENVIRONMENTAL CONDITIONS	23deg. C, 71%RH	TESTED BY	Alan Wu

ANTENNA POLARITY & TEST DISTANCE: HORIZONTAL AT 3 M								
NO.	FREQ. (MHz)	EMISSION LEVEL (dBuV/m)	LIMIT (dBuV/m)	MARGIN (dB)	ANTENNA HEIGHT (m)	TABLE ANGLE (Degree)	RAW VALUE (dBuV)	CORRECTION FACTOR (dB/m)
1	*916.00	90.0 PK	114.0	-24.0	1.47 H	39	63.40	26.60
2	*916.00	88.9 AV	94.0	-5.1	1.47 H	39	62.30	26.60
3	928.00	33.0 QP	46.0	-13.0	1.47 H	39	6.30	26.70
ANTENNA POLARITY & TEST DISTANCE: VERTICAL AT 3 M								
NO.	FREQ. (MHz)	EMISSION LEVEL (dBuV/m)	LIMIT (dBuV/m)	MARGIN (dB)	ANTENNA HEIGHT (m)	TABLE ANGLE (Degree)	RAW VALUE (dBuV)	CORRECTION FACTOR (dB/m)
1	*916.00	94.3 PK	114.0	-19.7	1.07 V	65	67.70	26.60
2	*916.00	92.7 AV	94.0	-1.3	1.07 V	65	66.10	26.60
3	928.00	34.9 QP	46.0	-11.1	1.07 V	65	8.20	26.70

- REMARKS:**
1. Emission level (dBuV/m) = Raw Value (dBuV) + Correction Factor (dB/m).
  2. Correction Factor (dB/m) = Antenna Factor (dB/m) + Cable Factor (dB).  
– Pre-Amplifier Factor(dB)
  3. The other emission levels were very low against the limit.
  4. Margin value = Emission level – Limit value.
  5. “ \* “ : Fundamental frequency



## ABOVE 1GHz DATA

EUT TEST CONDITION		MEASUREMENT DETAIL	
CHANNEL	Channel 1 (908.42MHz)	FREQUENCY RANGE	1 ~ 10GHz
INPUT POWER	120Vac, 60 Hz	DETECTOR FUNCTION	Peak (PK) Average (AV)
ENVIRONMENTAL CONDITIONS	23deg. C, 71%RH	TESTED BY	Alan Wu

ANTENNA POLARITY & TEST DISTANCE: HORIZONTAL AT 3 M								
NO.	FREQ. (MHz)	EMISSION LEVEL (dBuV/m)	LIMIT (dBuV/m)	MARGIN (dB)	ANTENNA HEIGHT (m)	TABLE ANGLE (Degree)	RAW VALUE (dBuV)	CORRECTION FACTOR (dB/m)
1	2725.26	50.8 PK	74.0	-23.2	1.08 H	115	52.10	-1.30
2	2725.26	48.3 AV	54.0	-5.7	1.08 H	115	49.60	-1.30
3	3633.68	44.7 PK	74.0	-29.3	1.13 H	131	43.70	1.00
4	3633.68	35.4 AV	54.0	-18.6	1.13 H	131	34.40	1.00

ANTENNA POLARITY & TEST DISTANCE: VERTICAL AT 3 M								
NO.	FREQ. (MHz)	EMISSION LEVEL (dBuV/m)	LIMIT (dBuV/m)	MARGIN (dB)	ANTENNA HEIGHT (m)	TABLE ANGLE (Degree)	RAW VALUE (dBuV)	CORRECTION FACTOR (dB/m)
1	2725.26	45.9 PK	74.0	-28.1	1.00 V	170	47.20	-1.30
2	2725.26	42.9 AV	54.0	-11.1	1.00 V	170	44.20	-1.30
3	3633.68	43.4 PK	74.0	-30.6	1.00 V	225	42.40	1.00
4	3633.68	31.9 AV	54.0	-22.1	1.00 V	225	30.90	1.00

- REMARKS:**
1. Emission level (dBuV/m) = Raw Value (dBuV) + Correction Factor (dB/m).
  2. Correction Factor (dB/m) = Antenna Factor (dB/m) + Cable Factor (dB).  
– Pre-Amplifier Factor(dB)
  3. The other emission levels were very low against the limit.
  4. Margin value = Emission level – Limit value.



A D T

EUT TEST CONDITION		MEASUREMENT DETAIL	
CHANNEL	Channel 2 (908.40MHz)	FREQUENCY RANGE	1 ~ 10GHz
INPUT POWER	120Vac, 60 Hz	DETECTOR FUNCTION	Peak (PK) Average (AV)
ENVIRONMENTAL CONDITIONS	23deg. C, 71%RH	TESTED BY	Alan Wu

ANTENNA POLARITY & TEST DISTANCE: HORIZONTAL AT 3 M								
NO.	FREQ. (MHz)	EMISSION LEVEL (dBuV/m)	LIMIT (dBuV/m)	MARGIN (dB)	ANTENNA HEIGHT (m)	TABLE ANGLE (Degree)	RAW VALUE (dBuV)	CORRECTION FACTOR (dB/m)
1	2725.20	50.3 PK	74.0	-23.7	1.03 H	110	51.60	-1.30
2	2725.20	48.1 AV	54.0	-5.9	1.03 H	110	49.40	-1.30
3	3633.60	45.2 PK	74.0	-28.8	1.25 H	133	44.20	1.00
4	3633.60	35.8 AV	54.0	-18.2	1.25 H	133	34.80	1.00

ANTENNA POLARITY & TEST DISTANCE: VERTICAL AT 3 M								
NO.	FREQ. (MHz)	EMISSION LEVEL (dBuV/m)	LIMIT (dBuV/m)	MARGIN (dB)	ANTENNA HEIGHT (m)	TABLE ANGLE (Degree)	RAW VALUE (dBuV)	CORRECTION FACTOR (dB/m)
1	2725.20	46.4 PK	74.0	-27.6	1.00 V	180	47.70	-1.30
2	2725.20	43.0 AV	54.0	-11.0	1.00 V	180	44.30	-1.30
3	3633.60	43.5 PK	74.0	-30.5	1.00 V	231	42.50	1.00
4	3633.60	32.5 AV	54.0	-21.5	1.00 V	231	31.50	1.00

- REMARKS:**
1. Emission level (dBuV/m) = Raw Value (dBuV) + Correction Factor (dB/m).
  2. Correction Factor (dB/m) = Antenna Factor (dB/m) + Cable Factor (dB).  
– Pre-Amplifier Factor(dB)
  3. The other emission levels were very low against the limit.
  4. Margin value = Emission level – Limit value.



A D T

EUT TEST CONDITION		MEASUREMENT DETAIL	
CHANNEL	Channel 3 (916.00MHz)	FREQUENCY RANGE	1 ~ 10GHz
INPUT POWER	120Vac, 60 Hz	DETECTOR FUNCTION	Peak (PK) Average (AV)
ENVIRONMENTAL CONDITIONS	23deg. C, 71%RH	TESTED BY	Alan Wu

ANTENNA POLARITY & TEST DISTANCE: HORIZONTAL AT 3 M								
NO.	FREQ. (MHz)	EMISSION LEVEL (dBuV/m)	LIMIT (dBuV/m)	MARGIN (dB)	ANTENNA HEIGHT (m)	TABLE ANGLE (Degree)	RAW VALUE (dBuV)	CORRECTION FACTOR (dB/m)
1	2748.00	51.0 PK	74.0	-23.0	1.05 H	115	52.30	-1.30
2	2748.00	48.5 AV	54.0	-5.5	1.05 H	115	49.80	-1.30
3	3664.00	45.5 PK	74.0	-28.5	1.27 H	132	44.50	1.00
4	3664.00	36.4 AV	54.0	-17.6	1.27 H	132	35.40	1.00

ANTENNA POLARITY & TEST DISTANCE: VERTICAL AT 3 M								
NO.	FREQ. (MHz)	EMISSION LEVEL (dBuV/m)	LIMIT (dBuV/m)	MARGIN (dB)	ANTENNA HEIGHT (m)	TABLE ANGLE (Degree)	RAW VALUE (dBuV)	CORRECTION FACTOR (dB/m)
1	2748.00	46.5 PK	74.0	-27.5	1.00 V	178	47.80	-1.30
2	2748.00	43.2 AV	54.0	-10.8	1.00 V	178	44.50	-1.30
3	3664.00	44.1 PK	74.0	-29.9	1.00 V	226	43.10	1.00
4	3664.00	32.6 AV	54.0	-21.4	1.00 V	226	31.60	1.00

- REMARKS:**
1. Emission level (dBuV/m) = Raw Value (dBuV) + Correction Factor (dB/m).
  2. Correction Factor (dB/m) = Antenna Factor (dB/m) + Cable Factor (dB).  
– Pre-Amplifier Factor(dB)
  3. The other emission levels were very low against the limit.
  4. Margin value = Emission level – Limit value.



## BELOW 1GHz DATA

EUT TEST CONDITION		MEASUREMENT DETAIL	
CHANNEL	Channel 1 (908.42MHz)	FREQUENCY RANGE	Below 1000MHz
INPUT POWER	120Vac, 60 Hz	DETECTOR FUNCTION	Quasi-Peak
ENVIRONMENTAL CONDITIONS	23deg. C, 71%RH	TESTED BY	Alan Wu

ANTENNA POLARITY & TEST DISTANCE: HORIZONTAL AT 3 M								
NO.	FREQ. (MHz)	EMISSION LEVEL (dBuV/m)	LIMIT (dBuV/m)	MARGIN (dB)	ANTENNA HEIGHT (m)	TABLE ANGLE (Degree)	RAW VALUE (dBuV)	CORRECTION FACTOR (dB/m)
1	127.00	26.7 QP	43.5	-16.8	1.49 H	277	42.20	-15.50
2	159.98	28.4 QP	43.5	-15.1	1.49 H	300	42.00	-13.60
3	400.54	35.6 QP	46.0	-10.4	1.00 H	18	46.40	-10.80
4	501.42	28.0 QP	46.0	-18.0	1.75 H	167	36.80	-8.80
5	600.36	30.3 QP	46.0	-15.7	1.49 H	170	37.00	-6.70
6	800.18	31.3 QP	46.0	-14.7	1.00 H	222	34.30	-3.00
ANTENNA POLARITY & TEST DISTANCE: VERTICAL AT 3 M								
NO.	FREQ. (MHz)	EMISSION LEVEL (dBuV/m)	LIMIT (dBuV/m)	MARGIN (dB)	ANTENNA HEIGHT (m)	TABLE ANGLE (Degree)	RAW VALUE (dBuV)	CORRECTION FACTOR (dB/m)
1	43.58	28.1 QP	40.0	-11.9	1.24 V	164	42.30	-14.20
2	127.00	24.4 QP	43.5	-19.1	1.00 V	216	39.90	-15.50
3	159.98	25.7 QP	43.5	-17.8	3.00 V	8	39.30	-13.60
4	400.54	30.8 QP	46.0	-15.2	1.24 V	275	41.60	-10.80
5	600.36	28.4 QP	46.0	-17.6	1.00 V	102	35.10	-6.70
6	800.18	34.5 QP	46.0	-11.5	1.24 V	293	37.50	-3.00

- REMARKS:**
1. Emission level (dBuV/m) = Raw Value (dBuV) + Correction Factor (dB/m).
  2. Correction Factor (dB/m) = Antenna Factor (dB/m) + Cable Factor (dB).  
– Pre-Amplifier Factor(dB)
  3. The other emission levels were very low against the limit.
  4. Margin value = Emission level – Limit value.



EUT TEST CONDITION		MEASUREMENT DETAIL	
CHANNEL	Channel 2 (908.40MHz)	FREQUENCY RANGE	Below 1000MHz
INPUT POWER	120Vac, 60 Hz	DETECTOR FUNCTION	Quasi-Peak
ENVIRONMENTAL CONDITIONS	23deg. C, 71%RH	TESTED BY	Alan Wu

ANTENNA POLARITY & TEST DISTANCE: HORIZONTAL AT 3 M								
NO.	FREQ. (MHz)	EMISSION LEVEL (dBuV/m)	LIMIT (dBuV/m)	MARGIN (dB)	ANTENNA HEIGHT (m)	TABLE ANGLE (Degree)	RAW VALUE (dBuV)	CORRECTION FACTOR (dB/m)
1	148.34	27.0 QP	43.5	-16.5	1.24 H	111	40.70	-13.70
2	159.98	27.6 QP	43.5	-15.9	1.24 H	99	41.20	-13.60
3	288.02	28.4 QP	46.0	-17.6	1.50 H	66	41.10	-12.70
4	352.04	26.9 QP	46.0	-19.1	1.00 H	40	38.60	-11.70
5	400.54	35.7 QP	46.0	-10.3	1.00 H	140	46.50	-10.80
6	800.18	31.3 QP	46.0	-14.7	1.00 H	221	34.30	-3.00
ANTENNA POLARITY & TEST DISTANCE: VERTICAL AT 3 M								
NO.	FREQ. (MHz)	EMISSION LEVEL (dBuV/m)	LIMIT (dBuV/m)	MARGIN (dB)	ANTENNA HEIGHT (m)	TABLE ANGLE (Degree)	RAW VALUE (dBuV)	CORRECTION FACTOR (dB/m)
1	33.88	26.6 QP	40.0	-13.4	1.24 V	227	41.90	-15.30
2	134.76	23.2 QP	43.5	-20.3	1.75 V	13	37.90	-14.70
3	159.98	26.6 QP	43.5	-16.9	1.00 V	38	40.20	-13.60
4	400.54	34.0 QP	46.0	-12.0	1.24 V	297	44.80	-10.80
5	495.60	24.1 QP	46.0	-21.9	1.00 V	252	33.10	-9.00
6	800.18	34.6 QP	46.0	-11.4	1.24 V	263	37.60	-3.00

- REMARKS:**
- Emission level (dBuV/m) = Raw Value (dBuV) + Correction Factor (dB/m).
  - Correction Factor (dB/m) = Antenna Factor (dB/m) + Cable Factor (dB).  
– Pre-Amplifier Factor(dB)
  - The other emission levels were very low against the limit.
  - Margin value = Emission level – Limit value.



EUT TEST CONDITION		MEASUREMENT DETAIL	
CHANNEL	Channel 3 (916.00MHz)	FREQUENCY RANGE	Below 1000MHz
INPUT POWER	120Vac, 60 Hz	DETECTOR FUNCTION	Quasi-Peak
ENVIRONMENTAL CONDITIONS	23deg. C, 71%RH	TESTED BY	David Huang

ANTENNA POLARITY & TEST DISTANCE: HORIZONTAL AT 3 M								
NO.	FREQ. (MHz)	EMISSION LEVEL (dBuV/m)	LIMIT (dBuV/m)	MARGIN (dB)	ANTENNA HEIGHT (m)	TABLE ANGLE (Degree)	RAW VALUE (dBuV)	CORRECTION FACTOR (dB/m)
1	127.00	28.0 QP	43.5	-15.5	1.24 H	274	43.50	-15.50
2	159.98	29.0 QP	43.5	-14.5	2.00 H	274	42.60	-13.60
3	224.00	26.4 QP	46.0	-19.6	1.00 H	229	42.90	-16.50
4	400.54	35.7 QP	46.0	-10.3	1.00 H	30	46.50	-10.80
5	600.36	34.3 QP	46.0	-11.7	1.49 H	7	41.00	-6.70
6	800.18	30.1 QP	46.0	-15.9	1.00 H	214	33.10	-3.00
ANTENNA POLARITY & TEST DISTANCE: VERTICAL AT 3 M								
NO.	FREQ. (MHz)	EMISSION LEVEL (dBuV/m)	LIMIT (dBuV/m)	MARGIN (dB)	ANTENNA HEIGHT (m)	TABLE ANGLE (Degree)	RAW VALUE (dBuV)	CORRECTION FACTOR (dB/m)
1	37.76	32.4 QP	40.0	-7.6	1.00 V	84	47.30	-14.90
2	127.00	24.7 QP	43.5	-18.8	1.49 V	206	40.20	-15.50
3	159.98	25.5 QP	43.5	-18.0	1.00 V	323	39.10	-13.60
4	400.54	30.3 QP	46.0	-15.7	1.24 V	277	41.10	-10.80
5	600.36	32.3 QP	46.0	-13.7	1.00 V	252	39.00	-6.70
6	800.18	35.2 QP	46.0	-10.8	1.24 V	244	38.20	-3.00

- REMARKS:**
- Emission level (dBuV/m) = Raw Value (dBuV) + Correction Factor (dB/m).
  - Correction Factor (dB/m) = Antenna Factor (dB/m) + Cable Factor (dB).  
– Pre-Amplifier Factor(dB)
  - The other emission levels were very low against the limit.
  - Margin value = Emission level – Limit value.

## 4.2 CONDUCTED EMISSION MEASUREMENT

### 4.2.1 LIMITS OF CONDUCTED EMISSION MEASUREMENT

FREQUENCY OF EMISSION (MHz)	CONDUCTED LIMIT (dB $\mu$ V)	
	Quasi-peak	Average
0.15-0.5	66 to 56	56 to 46
0.5-5	56	46
5-30	60	50

- NOTE:**
1. The lower limit shall apply at the transition frequencies.
  2. The limit decreases in line with the logarithm of the frequency in the range of 0.15 to 0.50 MHz.
  3. All emanations from a class A/B digital device or system, including any network of conductors and apparatus connected thereto, shall not exceed the level of field strengths specified above.

### 4.2.2 TEST INSTRUMENTS

DESCRIPTION & MANUFACTURER	MODEL NO.	SERIAL NO.	DATE OF CALIBRATION	DUE DATE OF CALIBRATION
Test Receiver ROHDE & SCHWARZ	ESCS30	100289	Nov. 29, 2013	Nov. 28, 2014
RF signal cable Woken	5D-FB	Cable-HYC01-01	Dec. 27, 2013	Dec. 26, 2014
LISN ROHDE & SCHWARZ (EUT)	ESH3-Z5	835239/001	Feb. 13, 2014	Feb. 12, 2015
LISN ROHDE & SCHWARZ (Peripheral)	ESH3-Z5	100311	Jul. 21, 2014	Jul. 20, 2015
Software ADT	BV ADT_Cond_ V7.3.7.3	NA	NA	NA

- NOTE:**
1. The calibration interval of the above test instruments is 12 months and the calibrations are traceable to NML/ROC and NIST/USA.
  2. The test was performed in HwaYa Shielded Room 1.
  3. The VCCI Site Registration No. is C-2047.



#### 4.2.3 TEST PROCEDURES

- a. The EUT was placed 0.4 meters from the conducting wall of the shielded room with EUT being connected to the power mains through a line impedance stabilization network (LISN). Other support units were connected to the power mains through another LISN. The two LISNs provide 50 ohm/ 50uH of coupling impedance for the measuring instrument.
- b. Both lines of the power mains connected to the EUT were checked for maximum conducted interference.
- c. The frequency range from 150kHz to 30MHz was searched. Emission levels under (Limit - 20dB) was not recorded.

**NOTE:** All modes of operation were investigated and the worst-case emissions are reported.

#### 4.2.4 DEVIATION FROM TEST STANDARD

No deviation.

#### 4.2.5 TEST SETUP

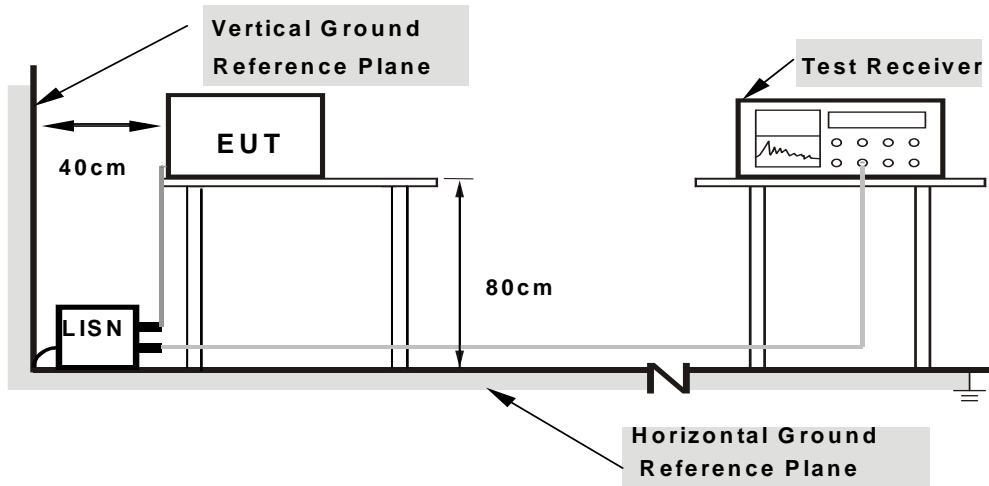

- Note:**
1. Support units were connected to second LISN.
  2. Both of LISNs (AMN) are 80 cm from EUT and at least 80 from other units and other metal planes

For the actual test configuration, please refer to the attached file (Test Setup Photo).

#### 4.2.6 EUT OPERATING CONDITIONS

Same as 4.1.6.

### 4.2.7 TEST RESULTS

#### CONDUCTED WORST-CASE DATA :

<b>CHANNEL</b>	Channel 1 (908.42MHz)	<b>PHASE</b>	Line 1
<b>6dB BANDWIDTH</b>	9kHz		

No	Freq. [MHz]	Corr. Factor (dB)	Reading Value [dB (uV)]		Emission Level [dB (uV)]		Limit [dB (uV)]		Margin (dB)	
			Q.P.	AV.	Q.P.	AV.	Q.P.	AV.	Q.P.	AV.
			1	0.17346	0.10	48.04	33.68	48.14	33.78	64.79
2	0.22820	0.09	42.33	30.68	42.42	30.77	62.51	52.51	-20.09	-21.74
3	0.41979	0.11	37.97	30.84	38.08	30.95	57.45	47.45	-19.37	-16.50
4	1.17833	0.22	32.54	14.23	32.76	14.45	56.00	46.00	-23.24	-31.55
5	1.95642	0.25	28.62	21.05	28.87	21.30	56.00	46.00	-27.13	-24.70
6	3.97398	0.26	23.56	14.70	23.82	14.96	56.00	46.00	-32.18	-31.04

#### REMARKS:

1. Q.P. and AV. are abbreviations of quasi-peak and average individually.
2. The emission levels of other frequencies were very low against the limit.
3. Margin value = Emission level - Limit value
4. Correction factor = Insertion loss + Cable loss
5. Emission Level = Correction Factor + Reading Value

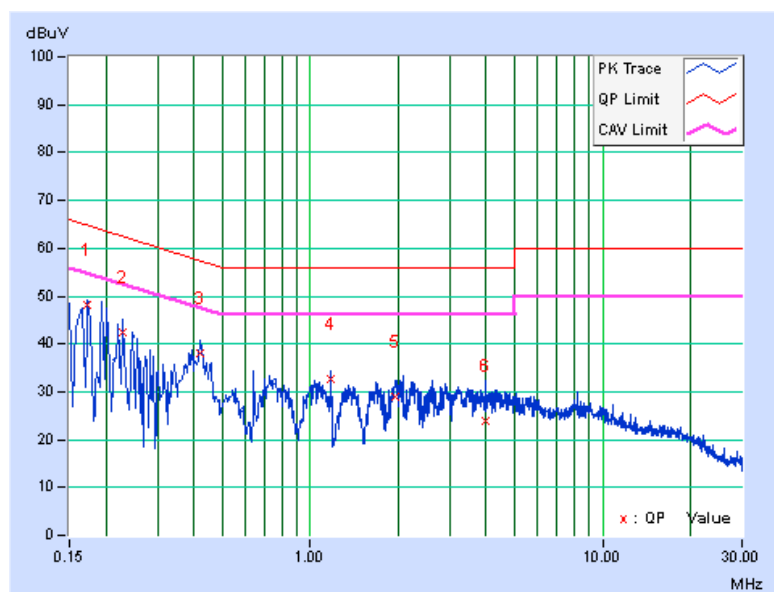

<b>CHANNEL</b>	Channel 1 (908.42MHz)	<b>PHASE</b>	Line 2
<b>6dB BANDWIDTH</b>	9kHz		

No	Freq. [MHz]	Corr. Factor (dB)	Reading Value		Emission Level		Limit		Margin	
			[dB (uV)]		[dB (uV)]		[dB (uV)]		(dB)	
			Q.P.	AV.	Q.P.	AV.	Q.P.	AV.	Q.P.	AV.
1	0.19301	0.08	44.70	31.87	44.78	31.95	63.91	53.91	-19.12	-21.95
2	0.41979	0.17	36.55	27.57	36.72	27.74	57.45	47.45	-20.73	-19.71
3	0.73814	0.20	28.79	19.32	28.99	19.52	56.00	46.00	-27.01	-26.48
4	1.72573	0.22	27.21	17.08	27.43	17.30	56.00	46.00	-28.57	-28.70
5	3.16083	0.24	26.52	16.24	26.76	16.48	56.00	46.00	-29.24	-29.52
6	7.89571	0.44	22.08	11.95	22.52	12.39	60.00	50.00	-37.48	-37.61

**REMARKS:**

1. Q.P. and AV. are abbreviations of quasi-peak and average individually.
2. The emission levels of other frequencies were very low against the limit.
3. Margin value = Emission level - Limit value
4. Correction factor = Insertion loss + Cable loss
5. Emission Level = Correction Factor + Reading Value

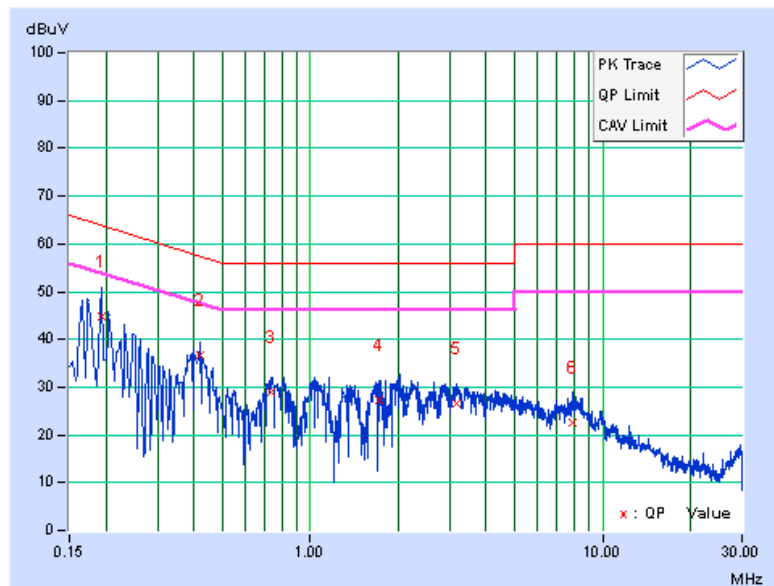

<b>CHANNEL</b>	Channel 2 (908.40MHz)	<b>PHASE</b>	Line 1
<b>6dB BANDWIDTH</b>	9kHz		

No	Freq. [MHz]	Corr. Factor (dB)	Reading Value		Emission Level		Limit		Margin	
			[dB (uV)]		[dB (uV)]		[dB (uV)]		(dB)	
			Q.P.	AV.	Q.P.	AV.	Q.P.	AV.	Q.P.	AV.
1	0.16569	0.10	48.38	33.14	48.48	33.24	65.17	55.17	-16.69	-21.93
2	0.23216	0.09	41.12	27.43	41.21	27.52	62.37	52.37	-21.16	-24.85
3	0.42000	0.11	37.72	30.90	37.83	31.01	57.45	47.45	-19.61	-16.43
4	0.90854	0.19	32.01	13.94	32.20	14.13	56.00	46.00	-23.80	-31.87
5	1.21352	0.22	31.26	12.10	31.48	12.32	56.00	46.00	-24.52	-33.68
6	2.03853	0.25	28.02	19.83	28.27	20.08	56.00	46.00	-27.73	-25.92

**REMARKS:**

1. Q.P. and AV. are abbreviations of quasi-peak and average individually.
2. The emission levels of other frequencies were very low against the limit.
3. Margin value = Emission level - Limit value
4. Correction factor = Insertion loss + Cable loss
5. Emission Level = Correction Factor + Reading Value

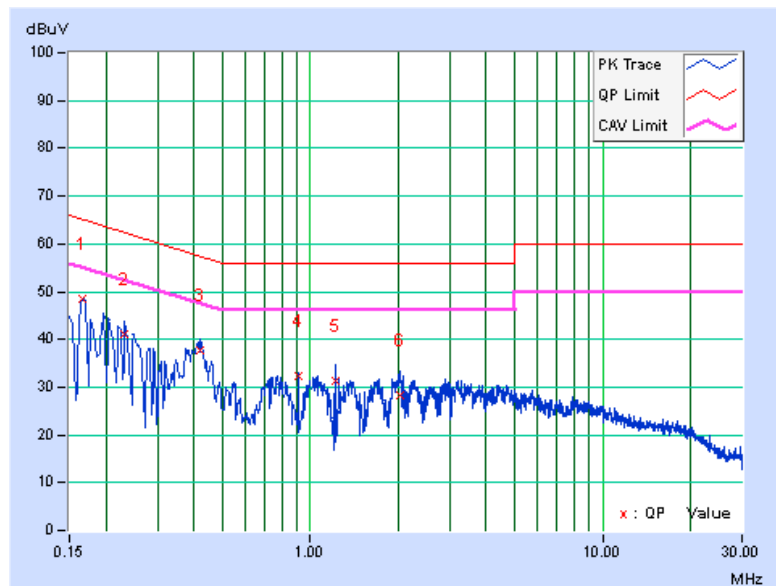

<b>CHANNEL</b>	Channel 2 (908.40MHz)	<b>PHASE</b>	Line 2
<b>6dB BANDWIDTH</b>	9kHz		

No	Freq. [MHz]	Corr. Factor (dB)	Reading Value		Emission Level		Limit		Margin	
			[dB (uV)]		[dB (uV)]		[dB (uV)]		(dB)	
			Q.P.	AV.	Q.P.	AV.	Q.P.	AV.	Q.P.	AV.
1	0.16967	0.07	49.22	39.11	49.29	39.18	64.98	54.98	-15.69	-15.80
2	0.22791	0.10	42.81	31.14	42.91	31.24	62.53	52.53	-19.61	-21.28
3	0.42370	0.17	36.01	27.61	36.18	27.78	57.38	47.38	-21.19	-19.59
4	0.92027	0.21	30.98	9.97	31.19	10.18	56.00	46.00	-24.81	-35.82
5	2.02680	0.22	27.95	17.72	28.17	17.94	56.00	46.00	-27.83	-28.06
6	4.86546	0.30	22.40	13.02	22.70	13.32	56.00	46.00	-33.30	-32.68

**REMARKS:**

1. Q.P. and AV. are abbreviations of quasi-peak and average individually.
2. The emission levels of other frequencies were very low against the limit.
3. Margin value = Emission level - Limit value
4. Correction factor = Insertion loss + Cable loss
5. Emission Level = Correction Factor + Reading Value

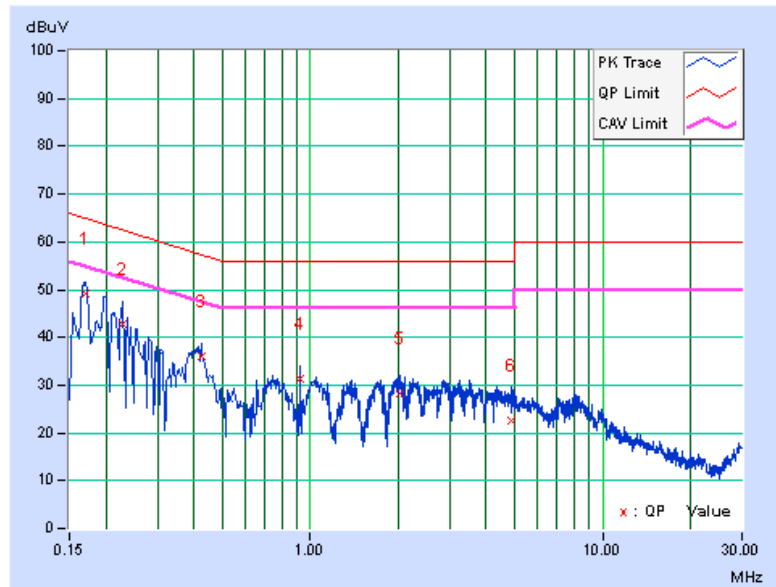

<b>CHANNEL</b>	Channel 3 (916.00MHz)	<b>PHASE</b>	Line 1
<b>6dB BANDWIDTH</b>	9kHz		

No	Freq. [MHz]	Corr. Factor (dB)	Reading Value		Emission Level		Limit		Margin	
			[dB (uV)]		[dB (uV)]		[dB (uV)]		(dB)	
			Q.P.	AV.	Q.P.	AV.	Q.P.	AV.	Q.P.	AV.
1	0.17147	0.10	48.36	34.89	48.46	34.99	64.89	54.89	-16.43	-19.90
2	0.20083	0.09	45.31	32.19	45.40	32.28	63.58	53.58	-18.18	-21.30
3	0.40800	0.11	35.34	27.81	35.45	27.92	57.69	47.69	-22.24	-19.77
4	0.74008	0.17	29.65	22.77	29.82	22.94	56.00	46.00	-26.18	-23.06
5	1.51068	0.23	30.43	10.80	30.66	11.03	56.00	46.00	-25.34	-34.97
6	2.81271	0.25	25.72	17.26	25.97	17.51	56.00	46.00	-30.03	-28.49

**REMARKS:**

1. Q.P. and AV. are abbreviations of quasi-peak and average individually.
2. The emission levels of other frequencies were very low against the limit.
3. Margin value = Emission level - Limit value
4. Correction factor = Insertion loss + Cable loss
5. Emission Level = Correction Factor + Reading Value

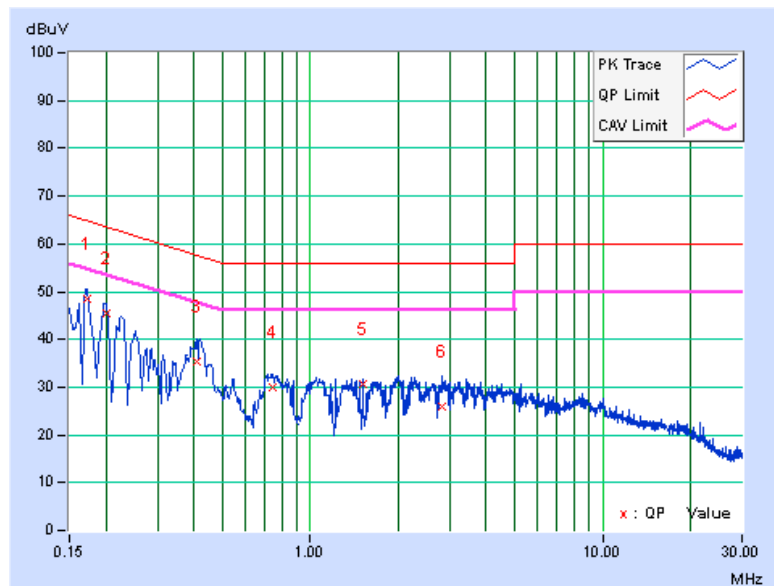

<b>CHANNEL</b>	Channel 3 (916.00MHz)	<b>PHASE</b>	Line 2
<b>6dB BANDWIDTH</b>	9kHz		

No	Freq. [MHz]	Corr. Factor (dB)	Reading Value		Emission Level		Limit		Margin	
			[dB (uV)]		[dB (uV)]		[dB (uV)]		(dB)	
			Q.P.	AV.	Q.P.	AV.	Q.P.	AV.	Q.P.	AV.
1	0.17283	0.07	47.82	37.26	47.89	37.33	64.82	54.82	-16.94	-17.50
2	0.20084	0.09	44.87	34.49	44.96	34.58	63.58	53.58	-18.62	-19.00
3	0.41588	0.17	36.71	26.85	36.88	27.02	57.53	47.53	-20.65	-20.51
4	1.06103	0.22	28.31	18.45	28.53	18.67	56.00	46.00	-27.47	-27.33
5	1.93687	0.22	27.61	17.38	27.83	17.60	56.00	46.00	-28.17	-28.40
6	7.91917	0.44	22.18	12.06	22.62	12.50	60.00	50.00	-37.38	-37.50

**REMARKS:**

1. Q.P. and AV. are abbreviations of quasi-peak and average individually.
2. The emission levels of other frequencies were very low against the limit.
3. Margin value = Emission level - Limit value
4. Correction factor = Insertion loss + Cable loss
5. Emission Level = Correction Factor + Reading Value

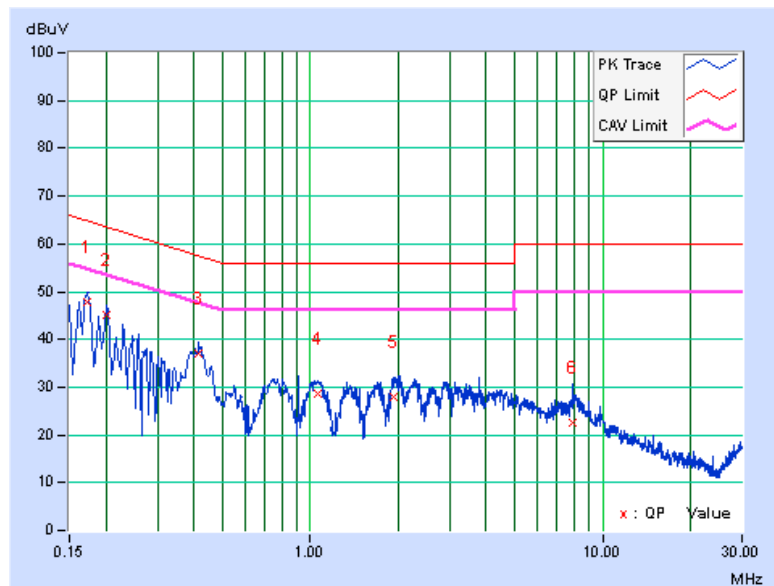





A D T

## 5. PHOTOGRAPHS OF THE TEST CONFIGURATION

Please refer to the attached file (Test Setup Photo).



## 6. INFORMATION ON THE TESTING LABORATORIES

We, Bureau Veritas Consumer Products Services (H.K.) Ltd., Taoyuan Branch, were founded in 1988 to provide our best service in EMC, Radio, Telecom and Safety consultation. Our laboratories are accredited and approved according to ISO/IEC 17025.

If you have any comments, please feel free to contact us at the following:

**Linko EMC/RF Lab**

Tel: 886-2-26052180

Fax: 886-2-26051924

**Hsin Chu EMC/RF/Telecom Lab**

Tel: 886-3-5935343

Fax: 886-3-5935342

**Hwa Ya EMC/RF/Safety Lab**

Tel: 886-3-3183232

Fax: 886-3-3270892

**Email:** [service.adt@tw.bureauveritas.com](mailto:service.adt@tw.bureauveritas.com)

**Web Site:** [www.bureauveritas-adt.com](http://www.bureauveritas-adt.com)

The address and road map of all our labs can be found in our web site also.

## **7. APPENDIX A - MODIFICATIONS RECORDERS FOR ENGINEERING CHANGES TO THE EUT BY THE LAB**

No any modifications are made to the EUT by the lab during the test.

--- END ---