



# FCC TEST REPORT (WLAN)

**REPORT NO.:** RF140924C03

**MODEL NO.:** DCH-G020, DCH-G020X

**FCC ID:** KA2CHG020A1

**RECEIVED:** Sep. 24, 2014

**TESTED:** Oct. 20 ~ Nov. 08, 2014

**ISSUED:** Nov. 10, 2014

**APPLICANT:** D-LINK CORPORATION

**ADDRESS:** 17595 Mt. Hermann, Fountain Valley, CA 92708,  
U.S.A.

**ISSUED BY:** Bureau Veritas Consumer Products Services  
(H.K.) Ltd., Taoyuan Branch

**LAB ADDRESS:** No. 47-2, 14th Ling, Chia Pau Vil., Lin Kou Dist.,  
New Taipei City, Taiwan, R.O.C.

**TEST LOCATION:** No. 19, Hwa Ya 2nd Rd, Wen Hwa Tsuen, Kwei  
Shan Hsiang, Taoyuan Hsien 333, Taiwan, R.O.C.

This report should not be used by the client to claim product certification, approval, or endorsement by TAF or any government agencies.



This report is for your exclusive use. Any copying or replication of this report to or for any other person or entity, or use of our name or trademark, is permitted only with our prior written permission. This report sets forth our findings solely with respect to the test samples identified herein. The results set forth in this report are not indicative or representative of the quality or characteristics of the lot from which a test sample was taken or any similar or identical product unless specifically and expressly noted. Our report includes all of the tests requested by you and the results thereof based upon the information that you provided to us. You have 60 days from date of issuance of this report to notify us of any material error or omission caused by our negligence, provided, however, that such notice shall be in writing and shall specifically address the issue you wish to raise. A failure to raise such issue within the prescribed time shall constitute your unqualified acceptance of the completeness of this report, the tests conducted and the correctness of the report contents. Unless specific mention, the uncertainty of measurement has been explicitly taken into account to declare the compliance or non-compliance to the specification.



## TABLE OF CONTENTS

RELEASE CONTROL RECORD.....	4
1. CERTIFICATION .....	5
2. SUMMARY OF TEST RESULTS .....	6
2.1 MEASUREMENT UNCERTAINTY.....	6
3. GENERAL INFORMATION.....	7
3.1 GENERAL DESCRIPTION OF EUT .....	7
3.2 DESCRIPTION OF TEST MODES.....	9
3.2.1 TEST MODE APPLICABILITY AND TESTED CHANNEL DETAIL.....	10
3.3 DUTY CYCLE OF TEST SIGNAL.....	12
3.4 DESCRIPTION OF SUPPORT UNITS .....	13
3.4.1 CONFIGURATION OF SYSTEM UNDER TEST .....	13
3.5 GENERAL DESCRIPTION OF APPLIED STANDARDS .....	13
4. TEST TYPES AND RESULTS .....	14
4.1 RADIATED EMISSION AND BANDEDGE MEASUREMENT.....	14
4.1.1 LIMITS OF RADIATED EMISSION AND BANDEDGE MEASUREMENT .....	14
4.1.2 TEST INSTRUMENTS.....	15
4.1.3 TEST PROCEDURES .....	16
4.1.4 DEVIATION FROM TEST STANDARD .....	16
4.1.5 TEST SETUP.....	17
4.1.6 EUT OPERATING CONDITIONS .....	17
4.1.7 TEST RESULTS .....	18
4.2 CONDUCTED EMISSION MEASUREMENT .....	31
4.2.1 LIMITS OF CONDUCTED EMISSION MEASUREMENT.....	31
4.2.2 TEST INSTRUMENTS.....	31
4.2.3 TEST PROCEDURES .....	32
4.2.4 DEVIATION FROM TEST STANDARD .....	32
4.2.5 TEST SETUP.....	32
4.2.6 EUT OPERATING CONDITIONS .....	32
4.2.7 TEST RESULTS .....	33
4.3 6dB BANDWIDTH MEASUREMENT.....	35
4.3.1 LIMITS OF 6dB BANDWIDTH MEASUREMENT .....	35
4.3.2 TEST SETUP.....	35
4.3.3 TEST INSTRUMENTS.....	35
4.3.4 TEST PROCEDURE.....	35
4.3.5 DEVIATION FROM TEST STANDARD .....	35
4.3.6 EUT OPERATING CONDITIONS .....	35
4.3.7 TEST RESULTS .....	36
4.4 CONDUCTED OUTPUT POWER .....	38
4.4.1 LIMITS OF CONDUCTED OUTPUT POWER MEASUREMENT .....	38
4.4.2 TEST SETUP.....	38
4.4.3 TEST INSTRUMENTS.....	38
4.4.4 TEST PROCEDURES .....	38
4.4.5 DEVIATION FROM TEST STANDARD .....	39
4.4.6 EUT OPERATING CONDITIONS .....	39
4.4.7 TEST RESULTS .....	40
4.5 POWER SPECTRAL DENSITY MEASUREMENT.....	41
4.5.1 LIMITS OF POWER SPECTRAL DENSITY MEASUREMENT .....	41
4.5.2 TEST SETUP.....	41
4.5.3 TEST INSTRUMENTS.....	41



A D T

4.5.4	TEST PROCEDURE.....	41
4.5.5	DEVIATION FROM TEST STANDARD .....	41
4.5.6	EUT OPERATING CONDITION .....	41
4.5.7	TEST RESULTS .....	42
4.6	CONDUCTED OUT OF BAND EMISSION MEASUREMENT.....	45
4.6.1	LIMITS OF CONDUCTED OUT OF BAND EMISSION MEASUREMENT .....	45
4.6.2	TEST SETUP.....	45
4.6.3	TEST INSTRUMENTS.....	45
4.6.4	TEST PROCEDURE.....	46
4.6.5	DEVIATION FROM TEST STANDARD .....	46
4.6.6	EUT OPERATING CONDITION .....	46
4.6.7	TEST RESULTS .....	46
5.	PHOTOGRAPHS OF THE TEST CONFIGURATION.....	55
6.	INFORMATION ON THE TESTING LABORATORIES .....	56
7.	APPENDIX A – MODIFICATIONS RECORDERS FOR ENGINEERING CHANGES TO THE EUT BY THE LAB.....	57



A D T

## RELEASE CONTROL RECORD

ISSUE NO.	REASON FOR CHANGE	DATE ISSUED
RF140924C03	Original release	Nov. 10, 2014

## 1. CERTIFICATION

**PRODUCT:** mydlink™ Connected Home Hub, Smart home hub  
**MODEL NO.:** DCH-G020, DCH-G020X  
**BRAND:** D-Link  
**APPLICANT:** D-LINK CORPORATION  
**TESTED:** Oct. 20 ~ Nov. 08, 2014  
**TEST SAMPLE:** ENGINEERING SAMPLE  
**STANDARDS:** FCC Part 15, Subpart C (Section 15.247)

The above equipment (model: DCH-G020) has been tested by **Bureau Veritas Consumer Products Services (H.K.) Ltd., Taoyuan Branch**, and found compliance with the requirement of the above standards. The test record, data evaluation & Equipment Under Test (EUT) configurations represented herein are true and accurate accounts of the measurements of the sample's EMC characteristics under the conditions specified in this report.

**PREPARED BY** : Celine Chou , **DATE** : Nov. 10, 2014  
Celine Chou / Specialist

**APPROVED BY** : Ken Liu , **DATE** : Nov. 10, 2014  
Ken Liu / Senior Manager

## 2. SUMMARY OF TEST RESULTS

The EUT has been tested according to the following specifications:

APPLIED STANDARD: FCC PART 15, SUBPART C (SECTION 15.247)			
STANDARD SECTION	TEST TYPE	RESULT	REMARK
15.207	AC Power Conducted Emission	PASS	Meet the requirement of limit. Minimum passing margin is -15.12dB at 0.16955MHz.
15.205 & 209	Radiated Emissions	PASS	Meet the requirement of limit. Minimum passing margin is -1.1dB at 2390.00MHz.
15.247(d)	Band Edge Measurement	PASS	Meet the requirement of limit. Minimum passing margin is -1.3dB at 2483.50MHz.
15.247(d)	Antenna Port Emission	PASS	Meet the requirement of limit.
15.247(a)(2)	6dB bandwidth	PASS	Meet the requirement of limit.
15.247(b)	Conducted power	PASS	Meet the requirement of limit.
15.247(e)	Power Spectral Density	PASS	Meet the requirement of limit.
15.203	Antenna Requirement	PASS	No antenna connector is used.

### 2.1 MEASUREMENT UNCERTAINTY

Where relevant, the following measurement uncertainty levels have been estimated for tests performed on the EUT as specified in CISPR 16-4-2:

MEASUREMENT	FREQUENCY	UNCERTAINTY
Conducted emissions	150kHz~30MHz	2.44 dB
Radiated emissions	30MHz ~ 200MHz	3.59 dB
	200MHz ~1000MHz	3.60 dB
	1GHz ~ 18GHz	2.29 dB
	18GHz ~ 40GHz	2.29 dB

This uncertainty represents an expanded uncertainty expressed at approximately the 95% confidence level using a coverage factor of  $k = 2$ .

### 3. GENERAL INFORMATION

#### 3.1 GENERAL DESCRIPTION OF EUT

<b>EUT</b>	mydlink™ Connected Home Hub, Smart home hub
<b>MODEL NO.</b>	DCH-G020, DCH-G020X
<b>POWER SUPPLY</b>	5Vdc from adapter
<b>MODULATION TYPE</b>	CCK, DQPSK, DBPSK for DSSS 64QAM, 16QAM, QPSK, BPSK for OFDM
<b>MODULATION TECHNOLOGY</b>	DSSS, OFDM
<b>TRANSFER RATE</b>	802.11b:11.0/ 5.5/ 2.0/ 1.0Mbps 802.11g: 54.0/ 48.0/ 36.0/ 24.0/ 18.0/ 12.0/ 9.0/ 6.0Mbps 802.11n: up to 300.0Mbps
<b>OPERATING FREQUENCY</b>	2412 ~ 2462MHz
<b>NUMBER OF CHANNEL</b>	11 for 802.11b, 802.11g, 802.11n (20MHz) 7 for 802.11n (40MHz)
<b>OUTPUT POWER</b>	210.878mW
<b>ANTENNA TYPE</b>	Patch antenna with 2dBi gain
<b>ANTENNA CONNECTOR</b>	N/A
<b>DATA CABLE</b>	N/A
<b>I/O PORTS</b>	Refer to user's manual
<b>ACCESSORY DEVICES</b>	Adapter

**NOTE:**

1. All models are listed as below..

Brand	Model	Product	Difference
D-Link	DCH-G020 (Main test model)	mydlink™ Connected Home Hub	with black base
	DCH-G020X	Smart home hub	with gray base

2. The EUT incorporates a MIMO function. Physically, the EUT provides two completed transmitters and two receivers.

MODULATION MODE	TX FUNCTION
802.11b	2TX
802.11g	2TX
802.11n (20MHz)	2TX
802.11n (40MHz)	2TX

3. The EUT consumes power from the following adapter.

<b>Adapter 1</b>	
<b>Brand</b>	Ktec
<b>Model</b>	KSAS0120500200D5
<b>Input Power</b>	100-240Vac, 50/60Hz, 0.4A
<b>Output Power</b>	5Vdc, 2A
<b>Power Line</b>	DC1.25m power cable without core attached on adapter

<b>Adapter 2</b>	
<b>Brand</b>	DVE
<b>Model</b>	DSA-12CA-05 050200
<b>Input Power</b>	100-240Vac, 50/60Hz, 0.3A
<b>Output Power</b>	5Vdc, 2A
<b>Power Line</b>	DC1.2m power cable without core attached on adapter

\* After pre-tested, adapter 2 was chosen for final test and presented in the test report.

4. The above EUT information is declared by manufacturer and for more detailed features description, please refer to the manufacturer's specifications or user's manual.





### 3.2 DESCRIPTION OF TEST MODES

11 channels are provided for 802.11b, 802.11g and 802.11n (20MHz):

CHANNEL	FREQUENCY	CHANNEL	FREQUENCY
1	2412MHz	7	2442MHz
2	2417MHz	8	2447MHz
3	2422MHz	9	2452MHz
4	2427MHz	10	2457MHz
5	2432MHz	11	2462MHz
6	2437MHz		

7 channels are provided for 802.11n (40MHz):

CHANNEL	FREQUENCY	CHANNEL	FREQUENCY
3	2422MHz	7	2442MHz
4	2427MHz	8	2447MHz
5	2432MHz	9	2452MHz
6	2437MHz		

### 3.2.1 TEST MODE APPLICABILITY AND TESTED CHANNEL DETAIL

EUT CONFIGURE MODE	APPLICABLE TO				DESCRIPTION
	RE≥1G	RE<1G	PLC	APCM	
-	√	√	√	√	-

Where **RE≥1G**: Radiated Emission above 1GHz      **RE<1G**: Radiated Emission below 1GHz  
**PLC**: Power Line Conducted Emission      **APCM**: Antenna Port Conducted Measurement

**NOTE:** The EUT had been pre-tested on the positioned of each 3 axis. The worst case was found when positioned on Z-plane.

#### RADIATED EMISSION TEST (ABOVE 1GHz):

- Pre-Scan has been conducted to determine the worst-case mode from all possible combinations between available modulations, data rates and antenna ports (if EUT with antenna diversity architecture).
- Following channel(s) was (were) selected for the final test as listed below.

EUT CONFIGURE MODE	MODE	AVAILABLE CHANNEL	TESTED CHANNEL	MODULATION TECHNOLOGY	MODULATION TYPE	DATA RATE (Mbps)
-	802.11b	1 to 11	1, 6, 11	DSSS	DBPSK	1.0
-	802.11g	1 to 11	1, 6, 11	OFDM	BPSK	6.0
-	802.11n (20MHz)	1 to 11	1, 6, 11	OFDM	BPSK	7.2
-	802.11n (40MHz)	3 to 9	3, 6, 9	OFDM	BPSK	15.0

#### RADIATED EMISSION TEST (BELOW 1GHz):

- Pre-Scan has been conducted to determine the worst-case mode from all possible combinations between available modulations, data rates and antenna ports (if EUT with antenna diversity architecture).
- Following channel(s) was (were) selected for the final test as listed below.

EUT CONFIGURE MODE	MODE	AVAILABLE CHANNEL	TESTED CHANNEL	MODULATION TECHNOLOGY	MODULATION TYPE	DATA RATE (Mbps)
-	802.11b	1 to 11	1	DSSS	DBPSK	1.0

#### POWER LINE CONDUCTED EMISSION TEST:

- Pre-Scan has been conducted to determine the worst-case mode from all possible combinations between available modulations, data rates and antenna ports (if EUT with antenna diversity architecture).
- Following channel(s) was (were) selected for the final test as listed below.

EUT CONFIGURE MODE	MODE	AVAILABLE CHANNEL	TESTED CHANNEL	MODULATION TECHNOLOGY	MODULATION TYPE	DATA RATE (Mbps)
-	802.11b	1 to 11	1	DSSS	DBPSK	1.0



**BANDEDGE MEASUREMENT:**

- Pre-Scan has been conducted to determine the worst-case mode from all possible combinations between available modulations, data rates and antenna ports (if EUT with antenna diversity architecture).
- Following channel(s) was (were) selected for the final test as listed below.

EUT CONFIGURE MODE	MODE	AVAILABLE CHANNEL	TESTED CHANNEL	MODULATION TECHNOLOGY	MODULATION TYPE	DATA RATE (Mbps)
-	802.11b	1 to 11	1, 11	DSSS	DBPSK	1.0
-	802.11g	1 to 11	1, 11	OFDM	BPSK	6.0
-	802.11n (20MHz)	1 to 11	1, 11	OFDM	BPSK	7.2
-	802.11n (40MHz)	3 to 9	3, 9	OFDM	BPSK	15.0

**ANTENNA PORT CONDUCTED MEASUREMENT:**

- This item includes all test value of each mode, but only includes spectrum plot of worst value of each mode.
- Pre-Scan has been conducted to determine the worst-case mode from all possible combinations between available modulations, data rates and antenna ports (if EUT with antenna diversity architecture).
- Following channel(s) was (were) selected for the final test as listed below.

EUT CONFIGURE MODE	MODE	AVAILABLE CHANNEL	TESTED CHANNEL	MODULATION TECHNOLOGY	MODULATION TYPE	DATA RATE (Mbps)
-	802.11b	1 to 11	1, 6, 11	DSSS	DBPSK	1.0
-	802.11g	1 to 11	1, 6, 11	OFDM	BPSK	6.0
-	802.11n (20MHz)	1 to 11	1, 6, 11	OFDM	BPSK	7.2
-	802.11n (40MHz)	3 to 9	3, 6, 9	OFDM	BPSK	15.0

**TEST CONDITION:**

APPLICABLE TO	ENVIRONMENTAL CONDITIONS	INPUT POWER	TESTED BY
RE≥1G	23deg. C, 70%RH	120Vac, 60Hz	Tank Wu
RE<1G	23deg. C, 71%RH	120Vac, 60Hz	Alan Wu
PLC	22deg. C, 72%RH	120Vac, 60Hz	Nick Hsu
APCM	24deg. C, 64%RH	120Vac, 60Hz	Match Tsui

### 3.3 DUTY CYCLE OF TEST SIGNAL

**802.11b:** Duty cycle of test signal is 100 %, duty factor is not required.

**802.11g, 802.11n (20MHz), 802.11n (40MHz):** Duty cycle is < 98%, duty factor shall be considered.

**802.11g:** Duty cycle =  $2.012/2.077 = 0.969$ , Duty factor =  $10 * \log( 1/0.969 ) = 0.14$

**802.11n (20MHz):** Duty cycle =  $1.882/1.937 = 0.972$ , Duty factor =  $10 * \log( 1/0.972 ) = 0.13$

**802.11n (40MHz):** Duty cycle =  $0.915/0.977 = 0.937$ , Duty factor =  $10 * \log( 1/0.937 ) = 0.28$



### 3.4 DESCRIPTION OF SUPPORT UNITS

The EUT has been tested as an independent unit.

#### 3.4.1 CONFIGURATION OF SYSTEM UNDER TEST

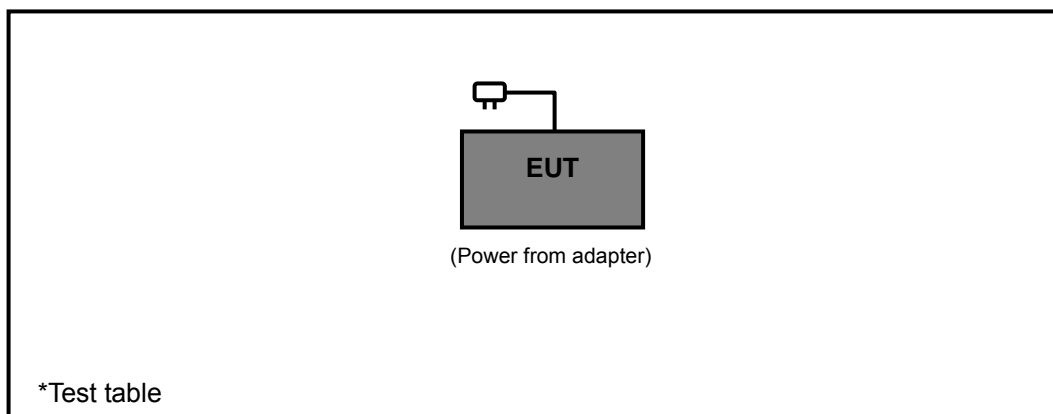

### 3.5 GENERAL DESCRIPTION OF APPLIED STANDARDS

The EUT is a RF Product. According to the specifications of the manufacturer, it must comply with the requirements of the following standards:

**FCC Part 15, Subpart C (15.247)**

**558074 D01 DTS Meas Guidance v03r02**

**662911 D01 Multiple Transmitter Output v02r01**

ANSI C63.10-2009

All test items have been performed and recorded as per the above standards.

**NOTE:** The EUT is also considered as a kind of computer peripheral, because the connection to computer is necessary for typical use. It has been verified to comply with the requirements of FCC Part 15, Subpart B, Class B (DoC). The test report has been issued separately.

## 4. TEST TYPES AND RESULTS

### 4.1 RADIATED EMISSION AND BANDEDGE MEASUREMENT

#### 4.1.1 LIMITS OF RADIATED EMISSION AND BANDEDGE MEASUREMENT

Radiated emissions which fall in the restricted bands must comply with the radiated emission limits specified as below table. Other emissions shall be at least 30dB below the highest level of the desired power:

FREQUENCIES (MHz)	FIELD STRENGTH (microvolts/meter)	MEASUREMENT DISTANCE (meters)
0.009 ~ 0.490	2400/F(kHz)	300
0.490 ~ 1.705	24000/F(kHz)	30
1.705 ~ 30.0	30	30
30 ~ 88	100	3
88 ~ 216	150	3
216 ~ 960	200	3
Above 960	500	3

**NOTE:**

1. The lower limit shall apply at the transition frequencies.
2. Emission level (dBuV/m) = 20 log Emission level (uV/m).
3. For frequencies above 1000MHz, the field strength limits are based on average detector, however, the peak field strength of any emission shall not exceed the maximum permitted average limits, specified above by more than 30dB under any condition of modulation.



A D T

#### 4.1.2 TEST INSTRUMENTS

DESCRIPTION & MANUFACTURER	MODEL NO.	SERIAL NO.	DATE OF CALIBRATION	DUE DATE OF CALIBRATION
Test Receiver ROHDE & SCHWARZ	ESCI	100424	Oct. 06, 2014	Oct. 05, 2015
Spectrum Analyzer ROHDE & SCHWARZ	FSU 43	100115	Dec. 18, 2013	Dec. 17, 2014
BILOG Antenna SCHWARZBECK	VULB9168	9168-155	Feb. 26, 2014	Feb. 25, 2015
HORN Antenna SCHWARZBECK	BBHA 9120D	9120D-404	Jan. 05, 2014	Jan. 04, 2015
HORN Antenna SCHWARZBECK	BBHA 9170	BBHA9170241	Feb. 17, 2014	Feb. 16, 2015
Preamplifier Agilent	8449B	3008A01961	Oct. 18, 2014	Oct. 17, 2015
Preamplifier Agilent	8447D	2944A10738	Oct. 18, 2014	Oct. 17, 2015
RF signal cable HUBER+SUHNNER	SUCOFLEX 104	309220/4	Aug. 09, 2014	Aug. 08, 2015
RF signal cable HUBER+SUHNNER	SUCOFLEX 104	250724/4	Aug. 09, 2014	Aug. 08, 2015
RF signal cable HUBER+SUHNNER	SUCOFLEX 104	295012/4	Aug. 09, 2014	Aug. 08, 2015
Software BV ADT	ADT_Radiated_ V7.6.15.9.4	NA	NA	NA
Antenna Tower inn-co GmbH	MA 4000	010303	NA	NA
Antenna Tower Controller inn-co GmbH	CO2000	019303	NA	NA
Turn Table BV ADT	TT100.	TT93021704	NA	NA
Turn Table Controller BV ADT	SC100.	SC93021704	NA	NA
High Speed Peak Power Meter	ML2495A	0824011	Jul. 26, 2014	Jul. 25, 2015
Power Sensor	MA2411B	0738171	Jul. 26, 2014	Jul. 25, 2015

- NOTE:**
1. The calibration interval of the above test instruments is 12 months and the calibrations are traceable to NML/ROC and NIST/USA.
  2. The test was performed in HwaYa Chamber 4.
  3. The horn antenna and HP preamplifier (model: 8449B) are used only for the measurement of emission frequency above 1GHz if tested.
  4. The FCC Site Registration No. is 460141.
  5. The IC Site Registration No. is IC7450F-4.

#### 4.1.3 TEST PROCEDURES

- a. The EUT was placed on the top of a rotating table 0.8 meters above the ground at a 3 meters semi-anechoic chamber. The table was rotated 360 degrees to determine the position of the highest radiation.
- b. The EUT was set 3 meters away from the interference-receiving antenna, which was mounted on the top of a variable-height antenna tower.
- c. Height of receiving antenna is varied from one meter to four meters above the ground to determine the maximum value of the field strength. Both horizontal and vertical polarizations of the antenna are set to make the measurement.
- d. For each suspected emission, the EUT was arranged to its worst case and then the antenna was tuned to heights from 1 meter to 4 meters and the rotatable table was turned from 0 degrees to 360 degrees to find the maximum reading.
- e. The test-receiver system was set to Peak Detect Function and Specified Bandwidth with Maximum Hold Mode.
- f. If the emission level of the EUT in peak mode was lower than the limit specified, then testing could be stopped and the peak values of the EUT would be reported. Otherwise the emissions would be re-tested one by one using peak, quasi-peak or average method as specified and then reported in a data sheet.

**NOTE:**

1. The resolution bandwidth and video bandwidth of test receiver/spectrum analyzer is 120kHz for Quasi-peak detection at frequency below 1GHz.
2. The resolution bandwidth of test receiver/spectrum analyzer is 1MHz and video bandwidth is 3MHz for Peak detection at frequency above 1GHz.
3. The resolution bandwidth of test receiver/spectrum analyzer is 1MHz and the video bandwidth is  $\geq 1/T$  (Duty cycle < 98%) or 10Hz(Duty cycle > 98%) for Average detection (AV) at frequency above 1GHz.
4. All modes of operation were investigated and the worst-case emissions are reported.

#### 4.1.4 DEVIATION FROM TEST STANDARD

No deviation.



#### 4.1.5 TEST SETUP

##### Frequency range 30MHz~1GHz

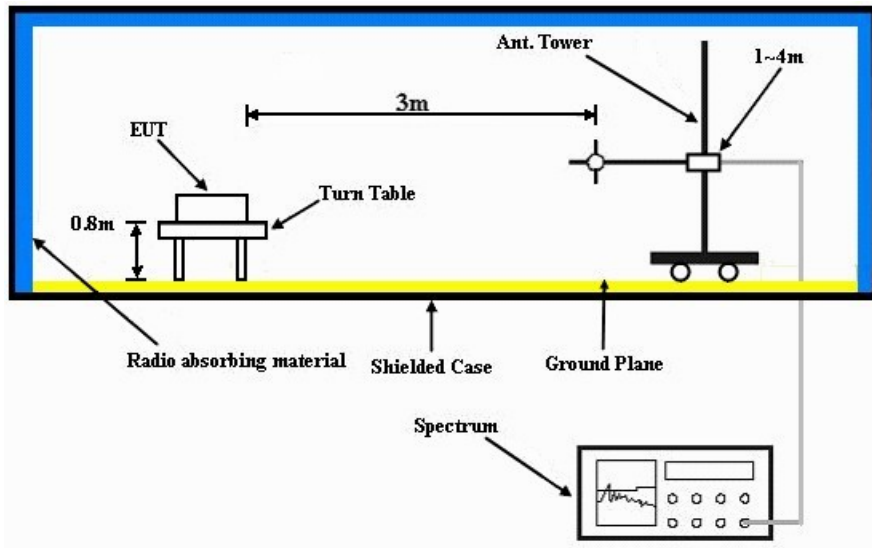

##### Frequency range above 1GHz

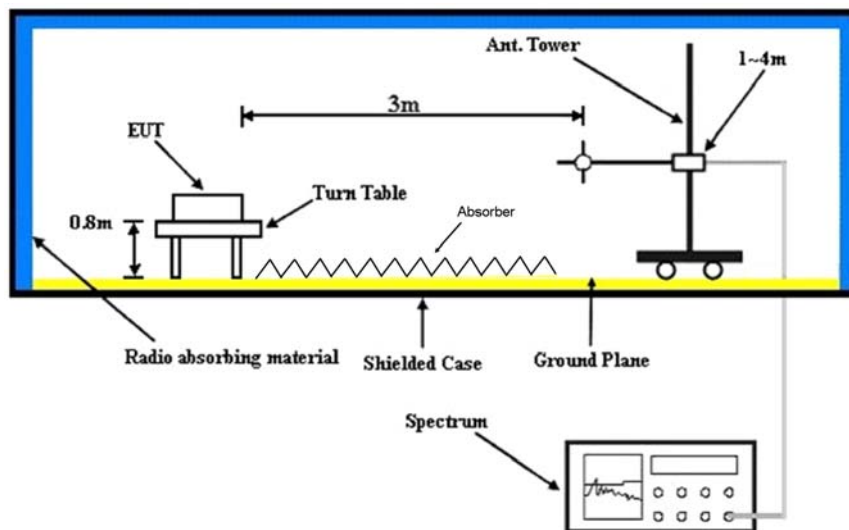

For the actual test configuration, please refer to the attached file (Test Setup Photo).

#### 4.1.6 EUT OPERATING CONDITIONS

Set the EUT under transmission condition continuously at specific channel frequency.



A D T

### 4.1.7 TEST RESULTS

#### ABOVE 1GHz DATA :

#### 802.11b

EUT TEST CONDITION		MEASUREMENT DETAIL	
CHANNEL	Channel 1	FREQUENCY RANGE	1 ~ 25GHz
INPUT POWER	120Vac, 60Hz	DETECTOR FUNCTION	Peak (PK) Average (AV)
ENVIRONMENTAL CONDITIONS	23deg. C, 70%RH	TESTED BY	Tank Wu

ANTENNA POLARITY & TEST DISTANCE: HORIZONTAL AT 3 M								
NO.	FREQ. (MHz)	EMISSION LEVEL (dBuV/m)	LIMIT (dBuV/m)	MARGIN (dB)	ANTENNA HEIGHT (m)	TABLE ANGLE (Degree)	RAW VALUE (dBuV)	CORRECTION FACTOR (dB/m)
1	2390.00	60.4 PK	74.0	-13.6	1.00 H	74	27.40	33.00
2	2390.00	48.4 AV	54.0	-5.6	1.00 H	74	15.40	33.00
3	*2412.00	104.7 PK			1.46 H	101	71.60	33.10
4	*2412.00	101.0 AV			1.46 H	101	67.90	33.10
5	4824.00	55.7 PK	74.0	-18.3	1.00 H	210	54.20	1.50
6	4824.00	53.6 AV	54.0	-0.4	1.00 H	210	52.10	1.50
ANTENNA POLARITY & TEST DISTANCE: VERTICAL AT 3 M								
NO.	FREQ. (MHz)	EMISSION LEVEL (dBuV/m)	LIMIT (dBuV/m)	MARGIN (dB)	ANTENNA HEIGHT (m)	TABLE ANGLE (Degree)	RAW VALUE (dBuV)	CORRECTION FACTOR (dB/m)
1	2390.00	61.2 PK	74.0	-12.8	1.00 V	228	28.20	33.00
2	2390.00	49.6 AV	54.0	-4.4	1.00 V	228	16.60	33.00
3	*2412.00	108.1 PK			1.48 V	27	75.00	33.10
4	*2412.00	104.4 AV			1.48 V	27	71.30	33.10
5	4824.00	51.6 PK	74.0	-22.4	1.00 V	294	50.10	1.50
6	4824.00	47.5 AV	54.0	-6.5	1.00 V	294	46.00	1.50

#### REMARKS:

1. Emission Level(dBuV/m) = Raw Value(dBuV) + Correction Factor(dB/m)
2. Correction Factor(dB/m) = Antenna Factor(dB/m) + Cable Factor(dB) – Pre-Amplifier Factor(dB)
3. The other emission levels were very low against the limit.
4. Margin value = Emission Level – Limit value
5. “ \* “: Fundamental frequency.



A D T

EUT TEST CONDITION		MEASUREMENT DETAIL	
CHANNEL	Channel 6	FREQUENCY RANGE	1 ~ 25GHz
INPUT POWER	120Vac, 60Hz	DETECTOR FUNCTION	Peak (PK) Average (AV)
ENVIRONMENTAL CONDITIONS	23deg. C, 70%RH	TESTED BY	Tank Wu

ANTENNA POLARITY & TEST DISTANCE: HORIZONTAL AT 3 M								
NO.	FREQ. (MHz)	EMISSION LEVEL (dBuV/m)	LIMIT (dBuV/m)	MARGIN (dB)	ANTENNA HEIGHT (m)	TABLE ANGLE (Degree)	RAW VALUE (dBuV)	CORRECTION FACTOR (dB/m)
1	*2437.00	104.2 PK			1.00 H	204	70.90	33.30
2	*2437.00	100.7 AV			1.00 H	204	67.40	33.30
3	4874.00	55.5 PK	74.0	-18.5	1.00 H	339	54.00	1.50
4	4874.00	53.5 AV	54.0	-0.5	1.00 H	339	52.00	1.50
ANTENNA POLARITY & TEST DISTANCE: VERTICAL AT 3 M								
NO.	FREQ. (MHz)	EMISSION LEVEL (dBuV/m)	LIMIT (dBuV/m)	MARGIN (dB)	ANTENNA HEIGHT (m)	TABLE ANGLE (Degree)	RAW VALUE (dBuV)	CORRECTION FACTOR (dB/m)
1	*2437.00	107.2 PK			1.15 V	9	73.90	33.30
2	*2437.00	103.8 AV			1.15 V	9	70.50	33.30
3	4874.00	50.3 PK	74.0	-23.7	1.00 V	67	48.80	1.50
4	4874.00	45.8 AV	54.0	-8.2	1.00 V	67	44.30	1.50

**REMARKS:**

1. Emission Level(dBuV/m) = Raw Value(dBuV) + Correction Factor(dB/m)
2. Correction Factor(dB/m) = Antenna Factor(dB/m) + Cable Factor(dB) – Pre-Amplifier Factor(dB)
3. The other emission levels were very low against the limit.
4. Margin value = Emission Level – Limit value
5. “ \* “: Fundamental frequency.



A D T

EUT TEST CONDITION		MEASUREMENT DETAIL	
CHANNEL	Channel 11	FREQUENCY RANGE	1 ~ 25GHz
INPUT POWER	120Vac, 60Hz	DETECTOR FUNCTION	Peak (PK) Average (AV)
ENVIRONMENTAL CONDITIONS	23deg. C, 70%RH	TESTED BY	Tank Wu

**ANTENNA POLARITY & TEST DISTANCE: HORIZONTAL AT 3 M**

NO.	FREQ. (MHz)	EMISSION LEVEL (dBuV/m)	LIMIT (dBuV/m)	MARGIN (dB)	ANTENNA HEIGHT (m)	TABLE ANGLE (Degree)	RAW VALUE (dBuV)	CORRECTION FACTOR (dB/m)
1	*2462.00	102.8 PK			1.05 H	152	69.40	33.40
2	*2462.00	98.7 AV			1.05 H	152	65.30	33.40
3	2483.50	61.4 PK	74.0	-12.6	1.00 H	2	28.00	33.40
4	2483.50	48.7 AV	54.0	-5.3	1.00 H	2	15.30	33.40
5	4924.00	55.4 PK	74.0	-18.6	1.00 H	5	53.80	1.60
6	4924.00	53.7 AV	54.0	-0.3	1.00 H	5	52.10	1.60

**ANTENNA POLARITY & TEST DISTANCE: VERTICAL AT 3 M**

NO.	FREQ. (MHz)	EMISSION LEVEL (dBuV/m)	LIMIT (dBuV/m)	MARGIN (dB)	ANTENNA HEIGHT (m)	TABLE ANGLE (Degree)	RAW VALUE (dBuV)	CORRECTION FACTOR (dB/m)
1	*2462.00	108.4 PK			1.16 V	33	75.00	33.40
2	*2462.00	104.9 AV			1.16 V	33	71.50	33.40
3	2483.50	61.2 PK	74.0	-12.8	1.07 V	15	27.80	33.40
4	2483.50	50.2 AV	54.0	-3.8	1.07 V	15	16.80	33.40
5	4924.00	51.0 PK	74.0	-23.0	1.00 V	203	49.40	1.60
6	4924.00	46.9 AV	54.0	-7.1	1.00 V	203	45.30	1.60

**REMARKS:**

1. Emission Level(dBuV/m) = Raw Value(dBuV) + Correction Factor(dB/m)
2. Correction Factor(dB/m) = Antenna Factor(dB/m) + Cable Factor(dB)  
– Pre-Amplifier Factor(dB)
3. The other emission levels were very low against the limit.
4. Margin value = Emission Level – Limit value
5. “ \* “: Fundamental frequency.



A D T

802.11g

EUT TEST CONDITION		MEASUREMENT DETAIL	
CHANNEL	Channel 1	FREQUENCY RANGE	1 ~ 25GHz
INPUT POWER	120Vac, 60Hz	DETECTOR FUNCTION	Peak (PK) Average (AV)
ENVIRONMENTAL CONDITIONS	23deg. C, 70%RH	TESTED BY	Tank Wu

ANTENNA POLARITY & TEST DISTANCE: HORIZONTAL AT 3 M

NO.	FREQ. (MHz)	EMISSION LEVEL (dBuV/m)	LIMIT (dBuV/m)	MARGIN (dB)	ANTENNA HEIGHT (m)	TABLE ANGLE (Degree)	RAW VALUE (dBuV)	CORRECTION FACTOR (dB/m)
1	2390.00	62.2 PK	74.0	-11.8	1.00 H	156	29.20	33.00
2	2390.00	52.9 AV	54.0	-1.1	1.00 H	156	19.90	33.00
3	*2412.00	113.5 PK			1.83 H	305	80.40	33.10
4	*2412.00	100.7 AV			1.83 H	305	67.60	33.10
5	4824.00	49.5 PK	74.0	-24.5	1.00 H	357	48.00	1.50
6	4824.00	36.1 AV	54.0	-17.9	1.00 H	357	34.60	1.50

ANTENNA POLARITY & TEST DISTANCE: VERTICAL AT 3 M

NO.	FREQ. (MHz)	EMISSION LEVEL (dBuV/m)	LIMIT (dBuV/m)	MARGIN (dB)	ANTENNA HEIGHT (m)	TABLE ANGLE (Degree)	RAW VALUE (dBuV)	CORRECTION FACTOR (dB/m)
1	2390.00	68.1 PK	74.0	-5.9	1.14 V	23	35.10	33.00
2	2390.00	53.2 AV	54.0	-0.8	1.14 V	23	20.20	33.00
3	*2412.00	113.5 PK			1.14 V	18	80.40	33.10
4	*2412.00	100.9 AV			1.14 V	18	67.80	33.10
5	4824.00	45.4 PK	74.0	-28.6	1.00 V	343	43.90	1.50
6	4824.00	33.7 AV	54.0	-20.3	1.00 V	343	32.20	1.50

REMARKS:

1. Emission Level(dBuV/m) = Raw Value(dBuV) + Correction Factor(dB/m)
2. Correction Factor(dB/m) = Antenna Factor(dB/m) + Cable Factor(dB) - Pre-Amplifier Factor(dB)
3. The other emission levels were very low against the limit.
4. Margin value = Emission Level - Limit value
5. " \* ": Fundamental frequency.



A D T

EUT TEST CONDITION		MEASUREMENT DETAIL	
CHANNEL	Channel 6	FREQUENCY RANGE	1 ~ 25GHz
INPUT POWER	120Vac, 60Hz	DETECTOR FUNCTION	Peak (PK) Average (AV)
ENVIRONMENTAL CONDITIONS	23deg. C, 70%RH	TESTED BY	Tank Wu

**ANTENNA POLARITY & TEST DISTANCE: HORIZONTAL AT 3 M**

NO.	FREQ. (MHz)	EMISSION LEVEL (dBuV/m)	LIMIT (dBuV/m)	MARGIN (dB)	ANTENNA HEIGHT (m)	TABLE ANGLE (Degree)	RAW VALUE (dBuV)	CORRECTION FACTOR (dB/m)
1	*2437.00	111.9 PK			1.00 H	322	78.60	33.30
2	*2437.00	100.9 AV			1.00 H	322	67.60	33.30
3	4874.00	46.2 PK	74.0	-27.8	1.00 H	170	44.70	1.50
4	4874.00	34.3 AV	54.0	-19.7	1.00 H	170	32.80	1.50

**ANTENNA POLARITY & TEST DISTANCE: VERTICAL AT 3 M**

NO.	FREQ. (MHz)	EMISSION LEVEL (dBuV/m)	LIMIT (dBuV/m)	MARGIN (dB)	ANTENNA HEIGHT (m)	TABLE ANGLE (Degree)	RAW VALUE (dBuV)	CORRECTION FACTOR (dB/m)
1	*2437.00	115.6 PK			1.09 V	32	82.30	33.30
2	*2437.00	103.6 AV			1.09 V	32	70.30	33.30
3	4874.00	43.6 PK	74.0	-30.4	1.00 V	301	42.10	1.50
4	4874.00	31.6 AV	54.0	-22.4	1.00 V	301	30.10	1.50

**REMARKS:**

- Emission Level(dBuV/m) = Raw Value(dBuV) + Correction Factor(dB/m)
- Correction Factor(dB/m) = Antenna Factor(dB/m) + Cable Factor(dB) – Pre-Amplifier Factor(dB)
- The other emission levels were very low against the limit.
- Margin value = Emission Level – Limit value
- “ \* “: Fundamental frequency.



A D T

EUT TEST CONDITION		MEASUREMENT DETAIL	
CHANNEL	Channel 11	FREQUENCY RANGE	1 ~ 25GHz
INPUT POWER	120Vac, 60Hz	DETECTOR FUNCTION	Peak (PK) Average (AV)
ENVIRONMENTAL CONDITIONS	23deg. C, 70%RH	TESTED BY	Tank Wu

**ANTENNA POLARITY & TEST DISTANCE: HORIZONTAL AT 3 M**

NO.	FREQ. (MHz)	EMISSION LEVEL (dBuV/m)	LIMIT (dBuV/m)	MARGIN (dB)	ANTENNA HEIGHT (m)	TABLE ANGLE (Degree)	RAW VALUE (dBuV)	CORRECTION FACTOR (dB/m)
1	*2462.00	111.5 PK			1.02 H	154	78.10	33.40
2	*2462.00	99.9 AV			1.02 H	154	66.50	33.40
3	2483.50	69.2 PK	74.0	-4.8	1.00 H	332	35.80	33.40
4	2483.50	52.4 AV	54.0	-1.6	1.00 H	332	19.00	33.40
5	4924.00	51.1 PK	74.0	-22.9	1.00 H	355	49.50	1.60
6	4924.00	37.2 AV	54.0	-16.8	1.00 H	355	35.60	1.60

**ANTENNA POLARITY & TEST DISTANCE: VERTICAL AT 3 M**

NO.	FREQ. (MHz)	EMISSION LEVEL (dBuV/m)	LIMIT (dBuV/m)	MARGIN (dB)	ANTENNA HEIGHT (m)	TABLE ANGLE (Degree)	RAW VALUE (dBuV)	CORRECTION FACTOR (dB/m)
1	*2462.00	113.2 PK			1.10 V	338	79.80	33.40
2	*2462.00	102.0 AV			1.10 V	338	68.60	33.40
3	2483.50	70.8 PK	74.0	-3.2	1.02 V	50	37.40	33.40
4	2483.50	53.2 AV	54.0	-0.8	1.02 V	50	19.80	33.40
5	4924.00	47.1 PK	74.0	-26.9	1.00 V	202	45.50	1.60
6	4924.00	34.3 AV	54.0	-19.7	1.00 V	202	32.70	1.60

**REMARKS:**

1. Emission Level(dBuV/m) = Raw Value(dBuV) + Correction Factor(dB/m)
2. Correction Factor(dB/m) = Antenna Factor(dB/m) + Cable Factor(dB)  
– Pre-Amplifier Factor(dB)
3. The other emission levels were very low against the limit.
4. Margin value = Emission Level – Limit value
5. “ \* “: Fundamental frequency.



A D T

802.11n (20MHz)

EUT TEST CONDITION		MEASUREMENT DETAIL	
CHANNEL	Channel 1	FREQUENCY RANGE	1 ~ 25GHz
INPUT POWER	120Vac, 60Hz	DETECTOR FUNCTION	Peak (PK) Average (AV)
ENVIRONMENTAL CONDITIONS	23deg. C, 70%RH	TESTED BY	Tank Wu

ANTENNA POLARITY & TEST DISTANCE: HORIZONTAL AT 3 M

NO.	FREQ. (MHz)	EMISSION LEVEL (dBuV/m)	LIMIT (dBuV/m)	MARGIN (dB)	ANTENNA HEIGHT (m)	TABLE ANGLE (Degree)	RAW VALUE (dBuV)	CORRECTION FACTOR (dB/m)
1	2390.00	62.8 PK	74.0	-11.2	1.00 H	95	29.80	33.00
2	2390.00	52.4 AV	54.0	-1.6	1.00 H	95	19.40	33.00
3	*2412.00	104.6 PK			1.23 H	117	71.50	33.10
4	*2412.00	93.3 AV			1.23 H	117	60.20	33.10
5	4824.00	50.0 PK	74.0	-24.0	1.00 H	348	48.50	1.50
6	4824.00	36.6 AV	54.0	-17.4	1.00 H	348	35.10	1.50

ANTENNA POLARITY & TEST DISTANCE: VERTICAL AT 3 M

NO.	FREQ. (MHz)	EMISSION LEVEL (dBuV/m)	LIMIT (dBuV/m)	MARGIN (dB)	ANTENNA HEIGHT (m)	TABLE ANGLE (Degree)	RAW VALUE (dBuV)	CORRECTION FACTOR (dB/m)
1	2390.00	62.1 PK	74.0	-11.9	1.00 V	201	29.10	33.00
2	2390.00	53.3 AV	54.0	-0.7	1.00 V	201	20.30	33.00
3	*2412.00	107.2 PK			1.79 V	68	74.10	33.10
4	*2412.00	96.4 AV			1.79 V	68	63.30	33.10
5	4824.00	45.7 PK	74.0	-28.3	1.00 V	333	44.20	1.50
6	4824.00	34.3 AV	54.0	-19.7	1.00 V	333	32.80	1.50

REMARKS:

1. Emission Level(dBuV/m) = Raw Value(dBuV) + Correction Factor(dB/m)
2. Correction Factor(dB/m) = Antenna Factor(dB/m) + Cable Factor(dB)  
- Pre-Amplifier Factor(dB)
3. The other emission levels were very low against the limit.
4. Margin value = Emission Level – Limit value
5. “ \* “: Fundamental frequency.





A D T

EUT TEST CONDITION		MEASUREMENT DETAIL	
CHANNEL	Channel 6	FREQUENCY RANGE	1 ~ 25GHz
INPUT POWER	120Vac, 60Hz	DETECTOR FUNCTION	Peak (PK) Average (AV)
ENVIRONMENTAL CONDITIONS	23deg. C, 70%RH	TESTED BY	Tank Wu

**ANTENNA POLARITY & TEST DISTANCE: HORIZONTAL AT 3 M**

NO.	FREQ. (MHz)	EMISSION LEVEL (dBuV/m)	LIMIT (dBuV/m)	MARGIN (dB)	ANTENNA HEIGHT (m)	TABLE ANGLE (Degree)	RAW VALUE (dBuV)	CORRECTION FACTOR (dB/m)
1	*2437.00	108.6 PK			1.00 H	339	75.30	33.30
2	*2437.00	98.0 AV			1.00 H	339	64.70	33.30
3	4874.00	53.1 PK	74.0	-20.9	1.37 H	13	51.60	1.50
4	4874.00	38.9 AV	54.0	-15.1	1.37 H	13	37.40	1.50

**ANTENNA POLARITY & TEST DISTANCE: VERTICAL AT 3 M**

NO.	FREQ. (MHz)	EMISSION LEVEL (dBuV/m)	LIMIT (dBuV/m)	MARGIN (dB)	ANTENNA HEIGHT (m)	TABLE ANGLE (Degree)	RAW VALUE (dBuV)	CORRECTION FACTOR (dB/m)
1	*2437.00	108.9 PK			1.33 V	227	75.60	33.30
2	*2437.00	98.3 AV			1.33 V	227	65.00	33.30
3	4874.00	47.8 PK	74.0	-26.2	1.00 V	339	46.30	1.50
4	4874.00	34.6 AV	54.0	-19.4	1.00 V	339	33.10	1.50

**REMARKS:**

- Emission Level(dBuV/m) = Raw Value(dBuV) + Correction Factor(dB/m)
- Correction Factor(dB/m) = Antenna Factor(dB/m) + Cable Factor(dB) – Pre-Amplifier Factor(dB)
- The other emission levels were very low against the limit.
- Margin value = Emission Level – Limit value
- “ \* “: Fundamental frequency.



A D T

EUT TEST CONDITION		MEASUREMENT DETAIL	
CHANNEL	Channel 11	FREQUENCY RANGE	1 ~ 25GHz
INPUT POWER	120Vac, 60Hz	DETECTOR FUNCTION	Peak (PK) Average (AV)
ENVIRONMENTAL CONDITIONS	23deg. C, 70%RH	TESTED BY	Tank Wu

**ANTENNA POLARITY & TEST DISTANCE: HORIZONTAL AT 3 M**

NO.	FREQ. (MHz)	EMISSION LEVEL (dBuV/m)	LIMIT (dBuV/m)	MARGIN (dB)	ANTENNA HEIGHT (m)	TABLE ANGLE (Degree)	RAW VALUE (dBuV)	CORRECTION FACTOR (dB/m)
1	*2462.00	105.1 PK			1.00 H	151	71.70	33.40
2	*2462.00	94.3 AV			1.00 H	151	60.90	33.40
3	2483.50	62.4 PK	74.0	-11.6	1.00 H	10	29.00	33.40
4	2483.50	50.7 AV	54.0	-3.3	1.00 H	10	17.30	33.40
5	4924.00	51.2 PK	74.0	-22.8	1.00 H	301	49.60	1.60
6	4924.00	37.4 AV	54.0	-16.6	1.00 H	301	35.80	1.60

**ANTENNA POLARITY & TEST DISTANCE: VERTICAL AT 3 M**

NO.	FREQ. (MHz)	EMISSION LEVEL (dBuV/m)	LIMIT (dBuV/m)	MARGIN (dB)	ANTENNA HEIGHT (m)	TABLE ANGLE (Degree)	RAW VALUE (dBuV)	CORRECTION FACTOR (dB/m)
1	*2462.00	109.6 PK			1.38 V	18	76.20	33.40
2	*2462.00	98.5 AV			1.38 V	18	65.10	33.40
3	2483.50	65.7 PK	74.0	-8.3	1.18 V	84	32.30	33.40
4	2483.50	53.0 AV	54.0	-1.0	1.18 V	84	19.60	33.40
5	4924.00	47.4 PK	74.0	-26.6	1.00 V	189	45.80	1.60
6	4924.00	34.7 AV	54.0	-19.3	1.00 V	189	33.10	1.60

**REMARKS:**

1. Emission Level(dBuV/m) = Raw Value(dBuV) + Correction Factor(dB/m)
2. Correction Factor(dB/m) = Antenna Factor(dB/m) + Cable Factor(dB)  
– Pre-Amplifier Factor(dB)
3. The other emission levels were very low against the limit.
4. Margin value = Emission Level – Limit value
5. “ \* “: Fundamental frequency.



A D T

802.11n (40MHz)

EUT TEST CONDITION		MEASUREMENT DETAIL	
CHANNEL	Channel 3	FREQUENCY RANGE	1 ~ 25GHz
INPUT POWER	120Vac, 60Hz	DETECTOR FUNCTION	Peak (PK) Average (AV)
ENVIRONMENTAL CONDITIONS	23deg. C, 70%RH	TESTED BY	Tank Wu

ANTENNA POLARITY & TEST DISTANCE: HORIZONTAL AT 3 M

NO.	FREQ. (MHz)	EMISSION LEVEL (dBuV/m)	LIMIT (dBuV/m)	MARGIN (dB)	ANTENNA HEIGHT (m)	TABLE ANGLE (Degree)	RAW VALUE (dBuV)	CORRECTION FACTOR (dB/m)
1	2390.00	67.0 PK	74.0	-7.0	1.00 H	147	34.00	33.00
2	2390.00	52.7 AV	54.0	-1.3	1.00 H	147	19.70	33.00
3	*2422.00	104.2 PK			1.00 H	315	71.00	33.20
4	*2422.00	92.1 AV			1.00 H	315	58.90	33.20
5	4844.00	47.4 PK	74.0	-26.6	1.00 H	243	45.90	1.50
6	4844.00	35.4 AV	54.0	-18.6	1.00 H	243	33.90	1.50

ANTENNA POLARITY & TEST DISTANCE: VERTICAL AT 3 M

NO.	FREQ. (MHz)	EMISSION LEVEL (dBuV/m)	LIMIT (dBuV/m)	MARGIN (dB)	ANTENNA HEIGHT (m)	TABLE ANGLE (Degree)	RAW VALUE (dBuV)	CORRECTION FACTOR (dB/m)
1	2390.00	68.8 PK	74.0	-5.2	1.00 V	248	35.80	33.00
2	2390.00	53.7 AV	54.0	-0.3	1.00 V	248	20.70	33.00
3	*2422.00	106.8 PK			1.33 V	160	73.60	33.20
4	*2422.00	93.5 AV			1.33 V	160	60.30	33.20
5	4844.00	47.3 PK	74.0	-26.7	1.00 V	80	45.80	1.50
6	4844.00	36.8 AV	54.0	-17.2	1.00 V	80	35.30	1.50

REMARKS:

1. Emission Level(dBuV/m) = Raw Value(dBuV) + Correction Factor(dB/m)
2. Correction Factor(dB/m) = Antenna Factor(dB/m) + Cable Factor(dB) - Pre-Amplifier Factor(dB)
3. The other emission levels were very low against the limit.
4. Margin value = Emission Level - Limit value
5. " \* ": Fundamental frequency.



A D T

EUT TEST CONDITION		MEASUREMENT DETAIL	
CHANNEL	Channel 6	FREQUENCY RANGE	1 ~ 25GHz
INPUT POWER	120Vac, 60Hz	DETECTOR FUNCTION	Peak (PK) Average (AV)
ENVIRONMENTAL CONDITIONS	23deg. C, 70%RH	TESTED BY	Tank Wu

**ANTENNA POLARITY & TEST DISTANCE: HORIZONTAL AT 3 M**

NO.	FREQ. (MHz)	EMISSION LEVEL (dBuV/m)	LIMIT (dBuV/m)	MARGIN (dB)	ANTENNA HEIGHT (m)	TABLE ANGLE (Degree)	RAW VALUE (dBuV)	CORRECTION FACTOR (dB/m)
1	2390.00	63.6 PK	74.0	-10.4	1.00 H	87	30.60	33.00
2	2390.00	51.0 AV	54.0	-3.0	1.00 H	87	18.00	33.00
3	*2437.00	103.4 PK			1.02 H	338	70.10	33.30
4	*2437.00	93.1 AV			1.02 H	338	59.80	33.30
5	2483.50	63.6 PK	74.0	-10.4	1.00 H	332	30.20	33.40
6	2483.50	50.6 AV	54.0	-3.4	1.00 H	332	17.20	33.40
7	4874.00	44.1 PK	74.0	-29.9	1.00 H	32	42.60	1.50
8	4874.00	32.7 AV	54.0	-21.3	1.00 H	32	31.20	1.50

**ANTENNA POLARITY & TEST DISTANCE: VERTICAL AT 3 M**

NO.	FREQ. (MHz)	EMISSION LEVEL (dBuV/m)	LIMIT (dBuV/m)	MARGIN (dB)	ANTENNA HEIGHT (m)	TABLE ANGLE (Degree)	RAW VALUE (dBuV)	CORRECTION FACTOR (dB/m)
1	2390.00	61.1 PK	74.0	-12.9	1.00 V	240	28.10	33.00
2	2390.00	49.8 AV	54.0	-4.2	1.00 V	240	16.80	33.00
3	*2437.00	108.8 PK			1.11 V	8	75.50	33.30
4	*2437.00	97.9 AV			1.11 V	8	64.60	33.30
5	2483.50	65.4 PK	74.0	-8.6	1.01 V	231	32.00	33.40
6	2483.50	52.9 AV	54.0	-1.1	1.01 V	231	19.50	33.40
7	4874.00	43.7 PK	74.0	-30.3	1.00 V	62	42.20	1.50
8	4874.00	32.7 AV	54.0	-21.3	1.00 V	62	31.20	1.50

**REMARKS:**

- Emission Level(dBuV/m) = Raw Value(dBuV) + Correction Factor(dB/m)
- Correction Factor(dB/m) = Antenna Factor(dB/m) + Cable Factor(dB) – Pre-Amplifier Factor(dB)
- The other emission levels were very low against the limit.
- Margin value = Emission Level – Limit value
- “ \* “: Fundamental frequency.



A D T

EUT TEST CONDITION		MEASUREMENT DETAIL	
CHANNEL	Channel 9	FREQUENCY RANGE	1 ~ 25GHz
INPUT POWER	120Vac, 60Hz	DETECTOR FUNCTION	Peak (PK) Average (AV)
ENVIRONMENTAL CONDITIONS	23deg. C, 70%RH	TESTED BY	Tank Wu

ANTENNA POLARITY & TEST DISTANCE: HORIZONTAL AT 3 M								
NO.	FREQ. (MHz)	EMISSION LEVEL (dBuV/m)	LIMIT (dBuV/m)	MARGIN (dB)	ANTENNA HEIGHT (m)	TABLE ANGLE (Degree)	RAW VALUE (dBuV)	CORRECTION FACTOR (dB/m)
1	*2452.00	104.9 PK			1.00 H	151	71.60	33.30
2	*2452.00	91.5 AV			1.00 H	151	58.20	33.30
3	2483.50	65.9 PK	74.0	-8.1	1.00 H	321	32.50	33.40
4	2483.50	53.1 AV	54.0	-0.9	1.00 H	321	19.70	33.40
5	4904.00	47.6 PK	74.0	-26.4	1.00 H	215	46.00	1.60
6	4904.00	34.6 AV	54.0	-19.4	1.00 H	215	33.00	1.60
ANTENNA POLARITY & TEST DISTANCE: VERTICAL AT 3 M								
NO.	FREQ. (MHz)	EMISSION LEVEL (dBuV/m)	LIMIT (dBuV/m)	MARGIN (dB)	ANTENNA HEIGHT (m)	TABLE ANGLE (Degree)	RAW VALUE (dBuV)	CORRECTION FACTOR (dB/m)
1	*2452.00	107.0 PK			1.12 V	49	73.70	33.30
2	*2452.00	94.0 AV			1.12 V	49	60.70	33.30
3	2483.50	68.9 PK	74.0	-5.1	1.08 V	18	35.50	33.40
4	2483.50	53.5 AV	54.0	-0.5	1.08 V	18	20.10	33.40
5	4904.00	47.9 PK	74.0	-26.1	1.00 V	53	46.30	1.60
6	4904.00	34.9 AV	54.0	-19.1	1.00 V	53	33.30	1.60

**REMARKS:**

1. Emission Level(dBuV/m) = Raw Value(dBuV) + Correction Factor(dB/m)
2. Correction Factor(dB/m) = Antenna Factor(dB/m) + Cable Factor(dB)  
- Pre-Amplifier Factor(dB)
3. The other emission levels were very low against the limit.
4. Margin value = Emission Level – Limit value
5. “ \* “: Fundamental frequency.



A D T

## BELOW 1GHz WORST-CASE DATA : 802.11b

EUT TEST CONDITION		MEASUREMENT DETAIL	
CHANNEL	Channel 1	FREQUENCY RANGE	Below 1000MHz
INPUT POWER	120Vac, 60Hz	DETECTOR FUNCTION	Quasi-Peak
ENVIRONMENTAL CONDITIONS	23deg. C, 71%RH	TESTED BY	Alan Wu

ANTENNA POLARITY & TEST DISTANCE: HORIZONTAL AT 3 M								
NO.	FREQ. (MHz)	EMISSION LEVEL (dBuV/m)	LIMIT (dBuV/m)	MARGIN (dB)	ANTENNA HEIGHT (m)	TABLE ANGLE (Degree)	RAW VALUE (dBuV)	CORRECTION FACTOR (dB/m)
1	159.91	31.7 QP	43.5	-11.8	1.49 H	96	45.30	-13.60
2	400.52	33.5 QP	46.0	-12.5	2.00 H	180	44.30	-10.80
3	600.38	34.9 QP	46.0	-11.1	1.24 H	193	41.60	-6.70
4	749.79	36.5 QP	46.0	-9.5	1.00 H	201	40.10	-3.60
5	858.45	34.3 QP	46.0	-11.7	1.49 H	207	36.60	-2.30
6	875.91	38.6 QP	46.0	-7.4	1.00 H	158	40.60	-2.00
ANTENNA POLARITY & TEST DISTANCE: VERTICAL AT 3 M								
NO.	FREQ. (MHz)	EMISSION LEVEL (dBuV/m)	LIMIT (dBuV/m)	MARGIN (dB)	ANTENNA HEIGHT (m)	TABLE ANGLE (Degree)	RAW VALUE (dBuV)	CORRECTION FACTOR (dB/m)
1	72.59	30.1 QP	40.0	-9.9	1.00 V	243	46.70	-16.60
2	138.56	30.9 QP	43.5	-12.6	1.00 V	99	45.20	-14.30
3	400.52	34.4 QP	46.0	-11.6	1.49 V	292	45.20	-10.80
4	600.38	31.6 QP	46.0	-14.4	1.00 V	275	38.30	-6.70
5	749.79	33.8 QP	46.0	-12.2	1.24 V	193	37.40	-3.60
6	875.91	37.8 QP	46.0	-8.2	1.00 V	181	39.80	-2.00

## REMARKS:

1. Emission Level(dBuV/m) = Raw Value(dBuV) + Correction Factor(dB/m)
2. Correction Factor(dB/m) = Antenna Factor(dB/m) + Cable Factor(dB)  
– Pre-Amplifier Factor (dB)
3. The other emission levels were very low against the limit.
4. Margin value = Emission Level – Limit value

## 4.2 CONDUCTED EMISSION MEASUREMENT

### 4.2.1 LIMITS OF CONDUCTED EMISSION MEASUREMENT

FREQUENCY OF EMISSION (MHz)	CONDUCTED LIMIT (dB $\mu$ V)	
	Quasi-peak	Average
0.15 ~ 0.5	66 to 56	56 to 46
0.5 ~ 5	56	46
5 ~ 30	60	50

- NOTE:**
1. The lower limit shall apply at the transition frequencies.
  2. The limit decreases in line with the logarithm of the frequency in the range of 0.15 to 0.50MHz.
  3. All emanations from a class A/B digital device or system, including any network of conductors and apparatus connected thereto, shall not exceed the level of field strengths specified above.

### 4.2.2 TEST INSTRUMENTS

DESCRIPTION & MANUFACTURER	MODEL NO.	SERIAL NO.	DATE OF CALIBRATION	DUE DATE OF CALIBRATION
Test Receiver ROHDE & SCHWARZ	ESCS30	100289	Nov. 29, 2013	Nov. 28, 2014
RF signal cable Woken	5D-FB	Cable-HYC01-01	Dec. 27, 2013	Dec. 26, 2014
LISN ROHDE & SCHWARZ (EUT)	ESH3-Z5	835239/001	Feb. 13, 2014	Feb. 12, 2015
LISN ROHDE & SCHWARZ (Peripheral)	ESH3-Z5	100311	Jul. 21, 2014	Jul. 20, 2015
Software ADT	BV ADT_Cond_ V7.3.7.3	NA	NA	NA

- NOTE:**
1. The calibration interval of the above test instruments is 12 months and the calibrations are traceable to NML/ROC and NIST/USA.
  2. The test was performed in HwaYa Shielded Room 1.
  3. The VCCI Site Registration No. is C-2047.

#### 4.2.3 TEST PROCEDURES

- a. The EUT was placed 0.4 meters from the conducting wall of the shielded room with EUT being connected to the power mains through a line impedance stabilization network (LISN). Other support units were connected to the power mains through another LISN. The two LISNs provide 50 ohm/ 50uH of coupling impedance for the measuring instrument.
- b. Both lines of the power mains connected to the EUT were checked for maximum conducted interference.
- c. The frequency range from 150kHz to 30MHz was searched. Emission levels under (Limit - 20dB) was not recorded.

**NOTE:** All modes of operation were investigated and the worst-case emissions are reported.

#### 4.2.4 DEVIATION FROM TEST STANDARD

No deviation.

#### 4.2.5 TEST SETUP

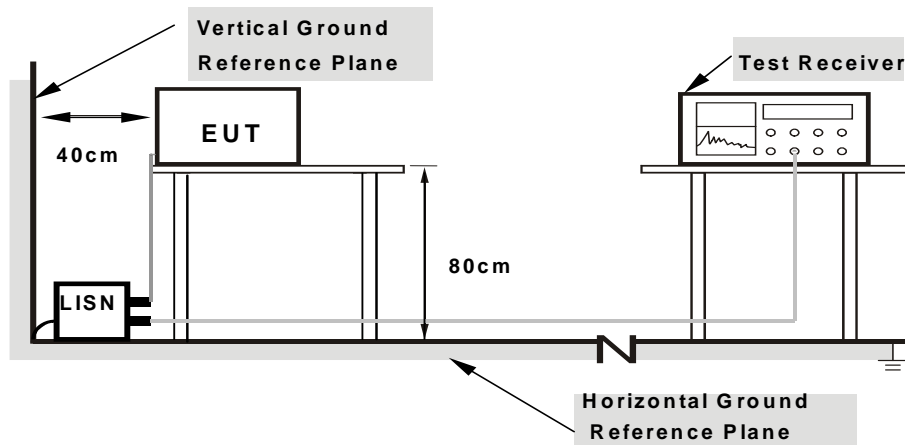

- Note:**
1. Support units were connected to second LISN.
  2. Both of LISNs (AMN) are 80 cm from EUT and at least 80 from other units and other metal planes

For the actual test configuration, please refer to the attached file (Test Setup Photo).

#### 4.2.6 EUT OPERATING CONDITIONS

Same as 4.1.6.



### 4.2.7 TEST RESULTS

#### CONDUCTED WORST-CASE DATA : 802.11b

PHASE	Line 1	6dB BANDWIDTH	9kHz
-------	--------	---------------	------

No	Freq. [MHz]	Corr. Factor (dB)	Reading Value		Emission Level		Limit		Margin	
			[dB (uV)]		[dB (uV)]		[dB (uV)]		(dB)	
			Q.P.	AV.	Q.P.	AV.	Q.P.	AV.	Q.P.	AV.
1	0.17328	0.10	49.57	34.60	49.67	34.70	64.80	54.80	-15.13	-20.10
2	0.20084	0.09	47.03	33.48	47.12	33.57	63.58	53.58	-16.46	-20.01
3	0.41979	0.11	37.87	31.06	37.98	31.17	57.45	47.45	-19.47	-16.28
4	1.04517	0.21	28.86	21.91	29.07	22.12	56.00	46.00	-26.93	-23.88
5	2.01961	0.25	28.21	20.20	28.46	20.45	56.00	46.00	-27.54	-25.55
6	3.52433	0.26	26.82	19.11	27.08	19.37	56.00	46.00	-28.92	-26.63

#### REMARKS:

1. Q.P. and AV. are abbreviations of quasi-peak and average individually.
2. The emission levels of other frequencies were very low against the limit.
3. Margin value = Emission level - Limit value
4. Correction factor = Insertion loss + Cable loss
5. Emission Level = Correction Factor + Reading Value

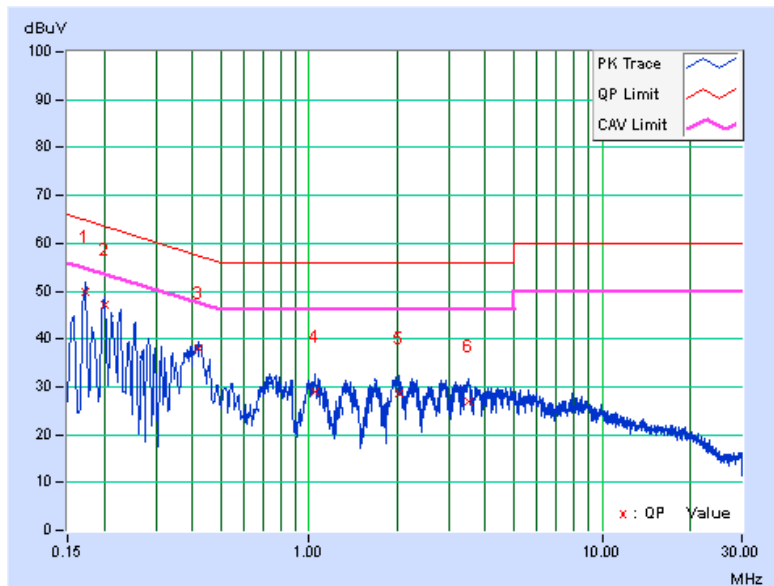

PHASE	Line 2	6dB BANDWIDTH	9kHz
-------	--------	---------------	------

No	Freq. [MHz]	Corr. Factor (dB)	Reading Value		Emission Level		Limit		Margin	
			[dB (uV)]		[dB (uV)]		[dB (uV)]		(dB)	
			Q.P.	AV.	Q.P.	AV.	Q.P.	AV.	Q.P.	AV.
1	0.16955	0.07	49.80	39.47	49.87	39.54	64.98	54.98	-15.12	-15.45
2	0.42000	0.17	36.45	27.92	36.62	28.09	57.45	47.45	-20.83	-19.36
3	0.77560	0.20	28.02	18.56	28.22	18.76	56.00	46.00	-27.78	-27.24
4	1.99552	0.22	28.27	18.22	28.49	18.44	56.00	46.00	-27.51	-27.56
5	3.41876	0.25	25.70	15.42	25.95	15.67	56.00	46.00	-30.05	-30.33
6	7.89571	0.44	21.63	11.75	22.07	12.19	60.00	50.00	-37.93	-37.81

**REMARKS:**

1. Q.P. and AV. are abbreviations of quasi-peak and average individually.
2. The emission levels of other frequencies were very low against the limit.
3. Margin value = Emission level - Limit value
4. Correction factor = Insertion loss + Cable loss
5. Emission Level = Correction Factor + Reading Value

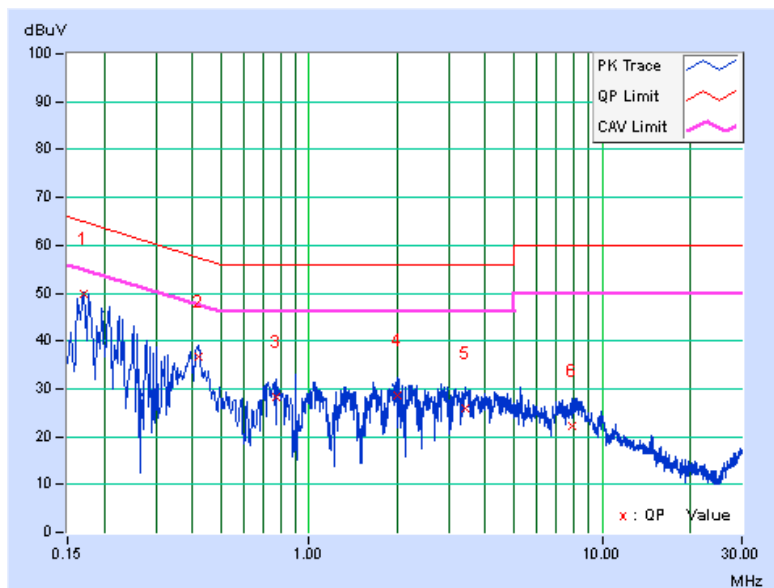

## 4.3 6dB BANDWIDTH MEASUREMENT

### 4.3.1 LIMITS OF 6dB BANDWIDTH MEASUREMENT

The minimum of 6dB Bandwidth Measurement is 0.5 MHz.

### 4.3.2 TEST SETUP

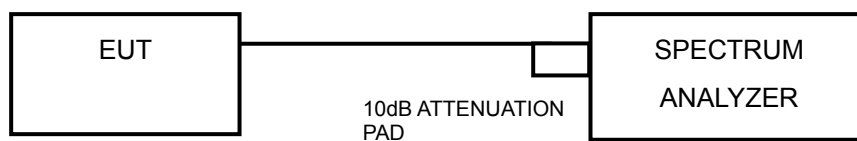

### 4.3.3 TEST INSTRUMENTS

Refer to section 4.1.2 to get information of above instrument.

### 4.3.4 TEST PROCEDURE

- a. Set resolution bandwidth (RBW) = 100kHz
- b. Set the video bandwidth (VBW)  $\geq 3 \times$  RBW, Detector = Peak.
- c. Trace mode = max hold.
- d. Sweep = auto couple.
- e. Measure the maximum width of the emission that is constrained by the frequencies associated with the two amplitude points (upper and lower) that are attenuated by 6 dB relative to the maximum level measured in the fundamental emission

### 4.3.5 DEVIATION FROM TEST STANDARD

No deviation.

### 4.3.6 EUT OPERATING CONDITIONS

The software provided by client to enable the EUT under transmission condition continuously at lowest, middle and highest channel frequencies individually.



## 4.3.7 TEST RESULTS

## 802.11b

CHANNEL	FREQUENCY (MHz)	6dB BANDWIDTH (MHz)		MINIMUM LIMIT (MHz)	PASS / FAIL
		CHAIN 0	CHAIN 1		
1	2412	10.06	10.03	0.5	PASS
6	2437	10.11	10.08	0.5	PASS
11	2462	10.11	10.09	0.5	PASS

## 802.11g

CHANNEL	FREQUENCY (MHz)	6dB BANDWIDTH (MHz)		MINIMUM LIMIT (MHz)	PASS / FAIL
		CHAIN 0	CHAIN 1		
1	2412	15.16	15.14	0.5	PASS
6	2437	15.15	15.15	0.5	PASS
11	2462	15.16	15.14	0.5	PASS

## 802.11n (20MHz)

CHANNEL	FREQUENCY (MHz)	6dB BANDWIDTH (MHz)		MINIMUM LIMIT (MHz)	PASS / FAIL
		CHAIN 0	CHAIN 1		
1	2412	15.16	15.16	0.5	PASS
6	2437	15.16	15.16	0.5	PASS
11	2462	15.16	15.14	0.5	PASS

## 802.11n (40MHz)

CHANNEL	FREQUENCY (MHz)	6dB BANDWIDTH (MHz)		MINIMUM LIMIT (MHz)	PASS / FAIL
		CHAIN 0	CHAIN 1		
3	2422	33.92	33.89	0.5	PASS
6	2437	32.67	32.70	0.5	PASS
9	2452	32.71	33.89	0.5	PASS



A D T

### SPECTRUM PLOT OF WORST VALUE

**802.11b**

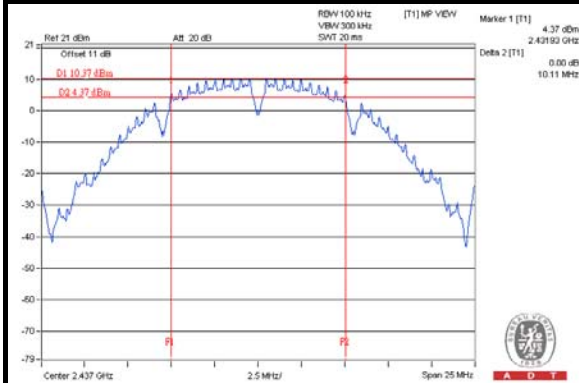

**802.11g**

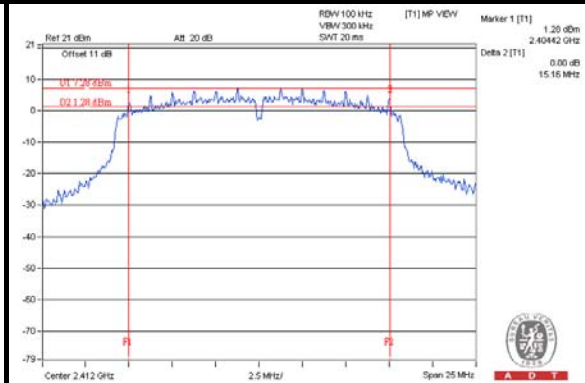

**802.11n (20MHz)**

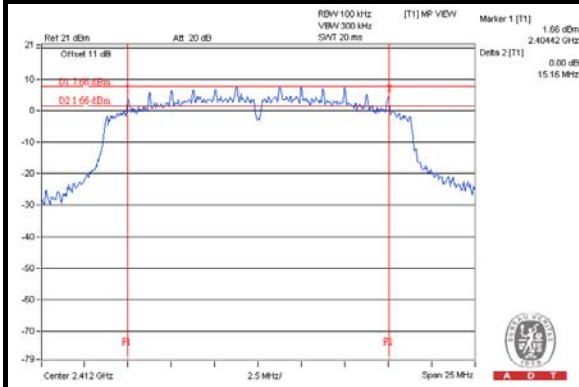

**802.11n (40MHz)**

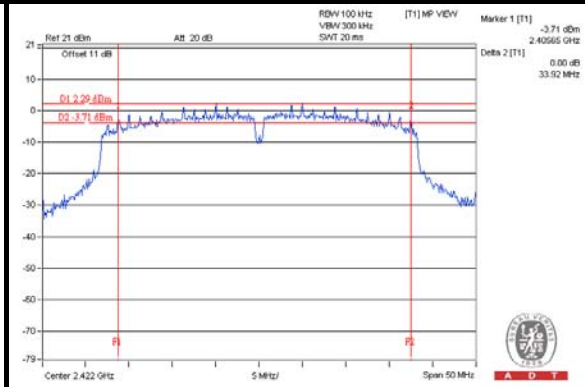

## 4.4 CONDUCTED OUTPUT POWER

### 4.4.1 LIMITS OF CONDUCTED OUTPUT POWER MEASUREMENT

For systems using digital modulation in the 2400–2483.5 MHz bands: 1 Watt (30dBm)

Per KDB 662911 D01 Multiple Transmitter Output v02r01 Method of conducted output power measurement on IEEE 802.11 devices,

Array Gain = 0 dB (i.e., no array gain) for  $NANT \leq 4$ ;

Array Gain = 0 dB (i.e., no array gain) for channel widths  $\geq 40$  MHz for any NANT;

Array Gain =  $5 \log(NANT/NSS)$  dB or 3 dB, whichever is less for 20-MHz channel widths with  $NANT \geq 5$ .

For power measurements on all other devices: Array Gain =  $10 \log(NANT/NSS)$  dB.

### 4.4.2 TEST SETUP

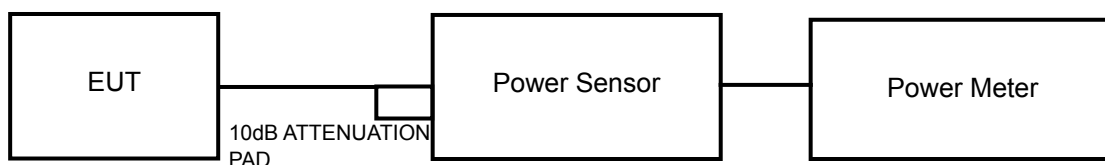

### 4.4.3 TEST INSTRUMENTS

Refer to section 4.1.2 to get information of above instrument.

### 4.4.4 TEST PROCEDURES

An average power sensor was used on the output port of the EUT. A power meter was used to read the response of the average power sensor. Record the power level.

#### 4.4.5 DEVIATION FROM TEST STANDARD

No deviation.

#### 4.4.6 EUT OPERATING CONDITIONS

Same as Item 4.3.6.



#### 4.4.7 TEST RESULTS

##### 802.11b

CHAN.	FREQ. (MHz)	AVG. POWER (dBm)		TOTAL POWER (mW)	TOTAL POWER (dBm)	LIMIT (dBm)	PASS / FAIL
		CHAIN 0	CHAIN 1				
1	2412	20.05	19.88	198.433	22.98	30	PASS
6	2437	20.23	20.23	<b>210.878</b>	23.24	30	PASS
11	2462	19.64	19.83	188.206	22.75	30	PASS

##### 802.11g

CHAN.	FREQ. (MHz)	AVG. POWER (dBm)		TOTAL POWER (mW)	TOTAL POWER (dBm)	LIMIT (dBm)	PASS / FAIL
		CHAIN 0	CHAIN 1				
1	2412	17.30	17.34	107.903	20.33	30	PASS
6	2437	19.02	18.85	156.535	21.95	30	PASS
11	2462	17.84	16.90	109.792	20.41	30	PASS

##### 802.11n (20MHz)

CHAN.	FREQ. (MHz)	AVG. POWER (dBm)		TOTAL POWER (mW)	TOTAL POWER (dBm)	LIMIT (dBm)	PASS / FAIL
		CHAIN 0	CHAIN 1				
1	2412	17.39	17.11	106.232	20.26	30	PASS
6	2437	18.87	18.57	149.035	21.73	30	PASS
11	2462	17.57	16.63	103.174	20.14	30	PASS

##### 802.11n (40MHz)

CHAN.	FREQ. (MHz)	AVG. POWER (dBm)		TOTAL POWER (mW)	TOTAL POWER (dBm)	LIMIT (dBm)	PASS / FAIL
		CHAIN 0	CHAIN 1				
3	2422	15.02	14.69	61.213	17.87	30	PASS
6	2437	18.54	17.79	131.567	21.19	30	PASS
9	2452	15.05	14.46	59.914	17.78	30	PASS



## 4.5 POWER SPECTRAL DENSITY MEASUREMENT

### 4.5.1 LIMITS OF POWER SPECTRAL DENSITY MEASUREMENT

The Maximum of Power Spectral Density Measurement is 8dBm.

### 4.5.2 TEST SETUP

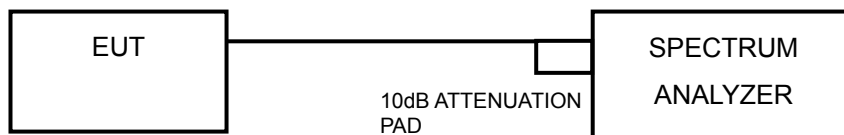

### 4.5.3 TEST INSTRUMENTS

Refer to section 4.1.2 to get information of above instrument.

### 4.5.4 TEST PROCEDURE

- a) Set instrument center frequency to DTS channel center frequency.
- b) Set span to at least 1.5 times the OBW.
- c) Set RBW to:  $3 \text{ kHz} \leq \text{RBW} \leq 100 \text{ kHz}$ .
- d) Set VBW  $\geq 3 \times \text{RBW}$ .
- e) Detector = power averaging (RMS) or sample detector (when RMS not available).
- f) Ensure that the number of measurement points in the sweep  $\geq 2 \times \text{span}/\text{RBW}$ .
- g) Sweep time = auto couple.
- h) Employ trace averaging (RMS) mode over a minimum of 100 traces.
- i) Use the peak marker function to determine the maximum amplitude level.

### 4.5.5 DEVIATION FROM TEST STANDARD

No deviation.

### 4.5.6 EUT OPERATING CONDITION

Same as Item 4.3.6

## 4.5.7 TEST RESULTS

### 802.11b

TX chain	Channel	Freq. (MHz)	PSD (dBm)	10 log (N=2) dB	Total PSD (dBm)	Limit (dBm)	PASS /FAIL
0	1	2412	-8.87	3.01	-5.86	8	PASS
	6	2437	-8.70	3.01	-5.69	8	PASS
	11	2462	-8.86	3.01	-5.85	8	PASS
1	1	2412	-8.84	3.01	-5.83	8	PASS
	6	2437	-8.14	3.01	-5.13	8	PASS
	11	2462	-9.11	3.01	-6.10	8	PASS

**NOTE:** Directional gain = 2dBi + 10log(2) = 5.01dBi < 6dBi, so the limit no need to reduced.

### 802.11g

TX chain	Channel	Freq. (MHz)	PSD (dBm)	10 log (N=2) dB	Duty Factor	Total PSD with duty factor (dBm)	Limit (dBm)	PASS /FAIL
0	1	2412	-12.50	3.01	0.14	-9.35	8	PASS
	6	2437	-11.15	3.01	0.14	-8.00	8	PASS
	11	2462	-12.52	3.01	0.14	-9.37	8	PASS
1	1	2412	-12.81	3.01	0.14	-9.66	8	PASS
	6	2437	-10.86	3.01	0.14	-7.71	8	PASS
	11	2462	-12.98	3.01	0.14	-9.83	8	PASS

**NOTE:**

- Method 1 of power density measurement of KDB 662911 is using for calculating total power density. Total power density is summing entire spectra across corresponding frequency bins on the various outputs by computer.
- Directional gain = 2dBi + 10log(2) = 5.01dBi < 6dBi, so the limit no need to reduced.
- Refer to section 3.3 for duty cycle spectrum plot.



A D T

### 802.11n (20MHz)

TX chain	Channel	Freq. (MHz)	PSD (dBm)	10 log (N=2) dB	Duty Factor	Total PSD with duty factor (dBm)	Limit (dBm)	PASS /FAIL
0	1	2412	-12.60	3.01	0.13	-9.46	8	PASS
	6	2437	-10.93	3.01	0.13	-7.79	8	PASS
	11	2462	-12.25	3.01	0.13	-9.11	8	PASS
1	1	2412	-12.84	3.01	0.13	-9.70	8	PASS
	6	2437	-10.86	3.01	0.13	-7.72	8	PASS
	11	2462	-13.44	3.01	0.13	-10.30	8	PASS

**NOTE:**

1. Method 1 of power density measurement of KDB 662911 is using for calculating total power density. Total power density is summing entire spectra across corresponding frequency bins on the various outputs by computer.
2. Directional gain = 2dBi + 10log(2) = 5.01dBi < 6dBi, so the limit no need to reduced.
3. Refer to section 3.3 for duty cycle spectrum plot.

### 802.11n (40MHz)

TX chain	Channel	Freq. (MHz)	PSD (dBm)	10 log (N=2) dB	Duty Factor	Total PSD with duty factor (dBm)	Limit (dBm)	PASS /FAIL
0	3	2422	-17.66	3.01	0.28	-14.37	8	PASS
	6	2437	-14.07	3.01	0.28	-10.78	8	PASS
	9	2452	-17.58	3.01	0.28	-14.29	8	PASS
1	3	2422	-18.12	3.01	0.28	-14.83	8	PASS
	6	2437	-15.14	3.01	0.28	-11.85	8	PASS
	9	2452	-18.57	3.01	0.28	-15.28	8	PASS

**NOTE:**

1. Method 1 of power density measurement of KDB 662911 is using for calculating total power density. Total power density is summing entire spectra across corresponding frequency bins on the various outputs by computer.
2. Directional gain = 2dBi + 10log(2) = 5.01dBi < 6dBi, so the limit no need to reduced.
3. Refer to section 3.3 for duty cycle spectrum plot.



A D T

### SPECTRUM PLOT OF WORST VALUE

**802.11b**

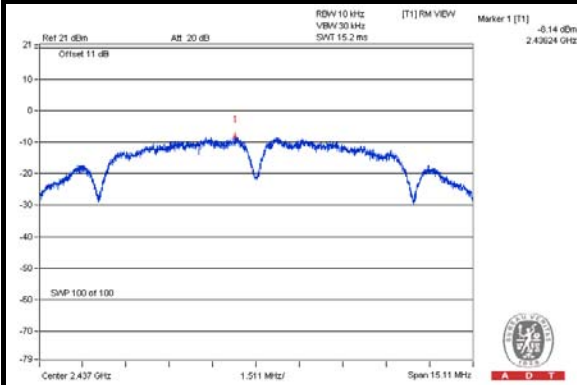

**802.11g**

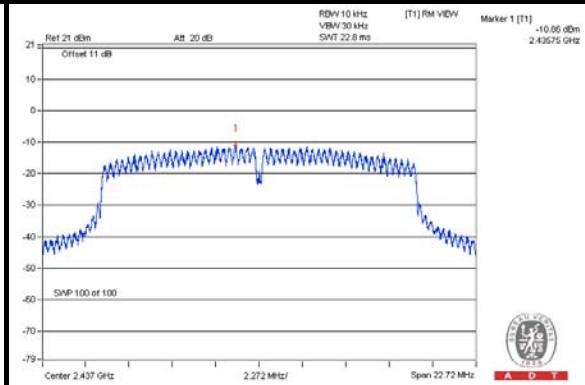

**802.11n (20MHz)**

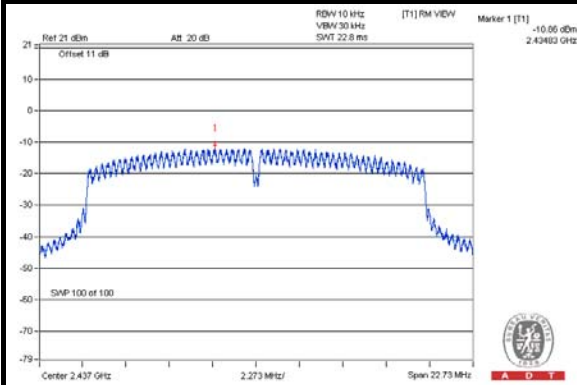

**802.11n (40MHz)**

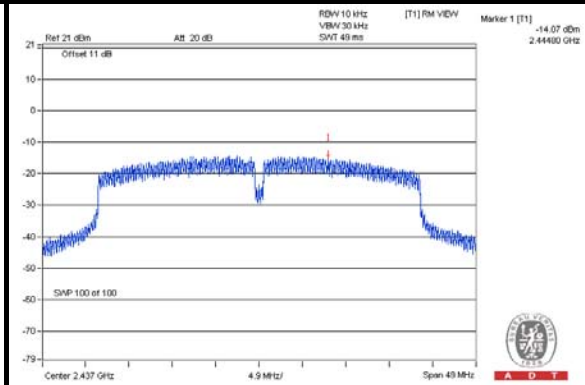

## 4.6 CONDUCTED OUT OF BAND EMISSION MEASUREMENT

### 4.6.1 LIMITS OF CONDUCTED OUT OF BAND EMISSION MEASUREMENT

Below  $-30\text{dB}$  of the highest emission level of operating band (in 100kHz Resolution Bandwidth).

### 4.6.2 TEST SETUP

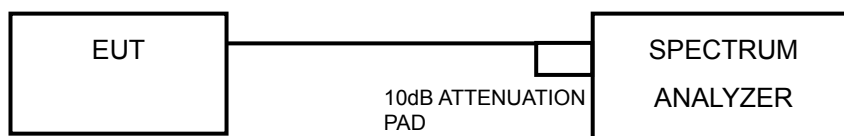

### 4.6.3 TEST INSTRUMENTS

Refer to section 4.1.2 to get information of above instrument.



#### 4.6.4 TEST PROCEDURE

##### **MEASUREMENT PROCEDURE REF**

1. Set the RBW = 100 kHz.
2. Set the VBW  $\geq$  300 kHz.
3. Detector = average.
4. Sweep time = auto couple.
5. Trace mode = max hold.
6. Allow trace to fully stabilize.
7. Use the peak marker function to determine the maximum power level in any 100 kHz band segment within the fundamental EBW.

##### **MEASUREMENT PROCEDURE OOB**

1. Set RBW = 100 kHz.
2. Set VBW  $\geq$  300 kHz.
3. Detector = peak.
4. Sweep = auto couple.
5. Trace Mode = max hold.
6. Allow trace to fully stabilize.
7. Use the peak marker function to determine the maximum amplitude level.

#### 4.6.5 DEVIATION FROM TEST STANDARD

No deviation.

#### 4.6.6 EUT OPERATING CONDITION

Same as Item 4.3.6

#### 4.6.7 TEST RESULTS

The conducted emission test is performed on each TX port of operating mode without summing or adding  $10\log(N)$  since the limit is relative emission limit. Only worst data of each operating mode is presented.

The spectrum plots are attached on the following pages. D1 line indicates the highest level, and D2 line indicates the 30dB offset below D1. It shows compliance with the requirement.



A D T

# 802.11b CHAIN 0

## CH 1

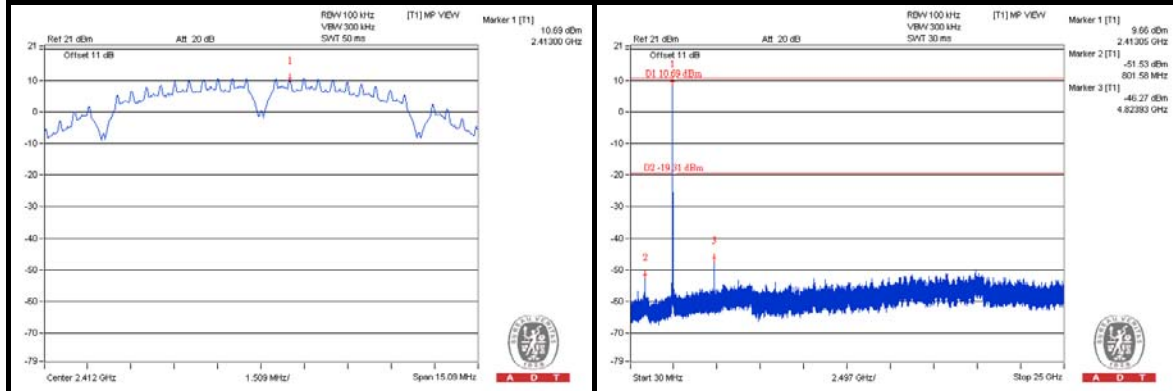

## CH 6

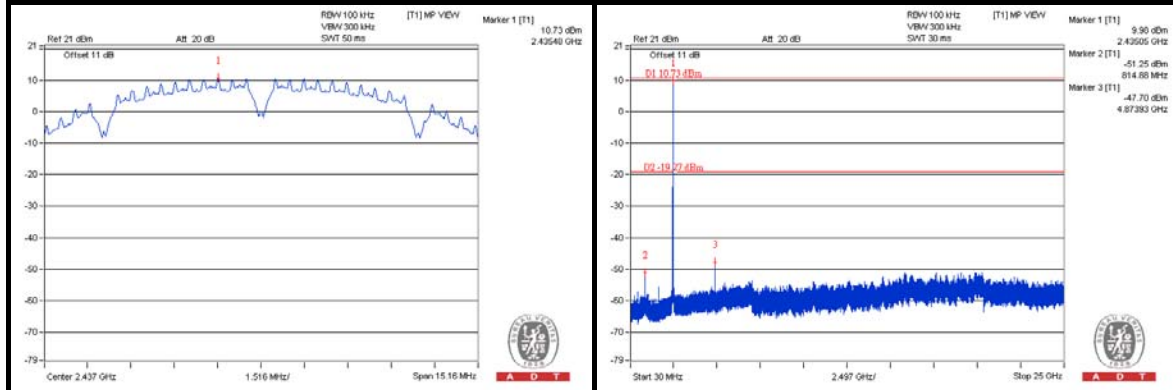

## CH 11

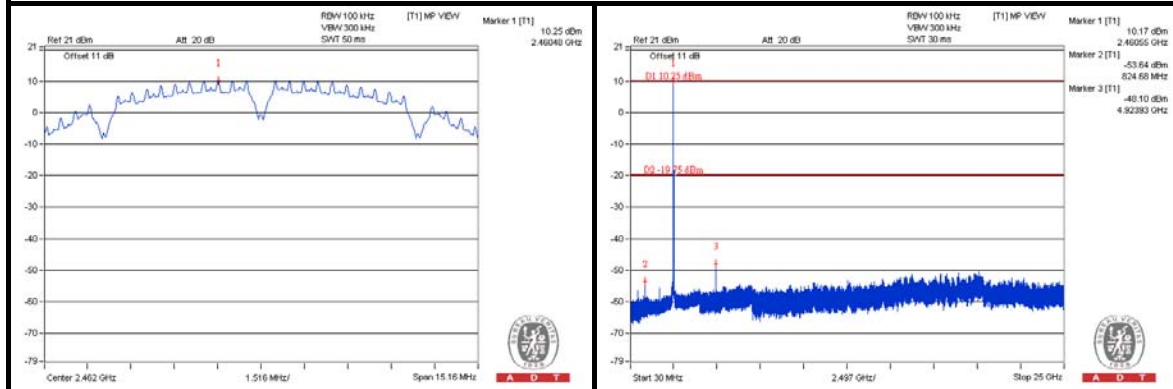

## CH 1 Band edge

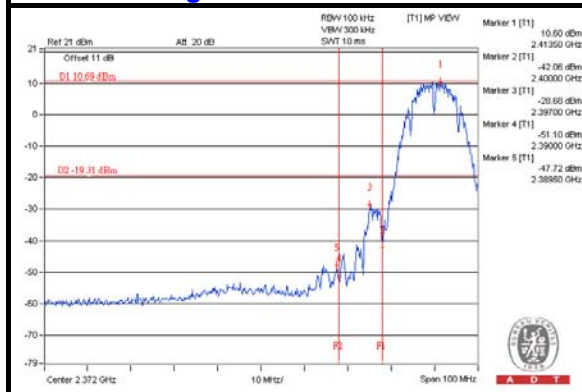

## CH 11 Band edge

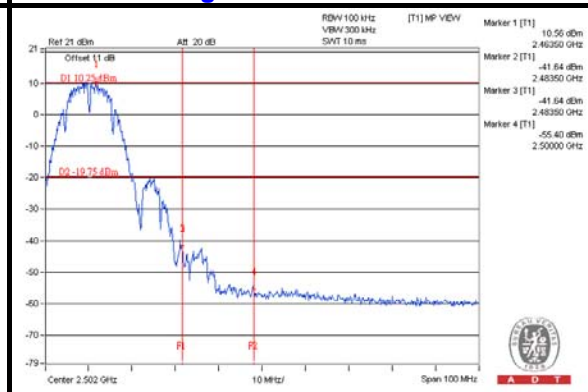



A D T

### CHAIN 1

#### CH 1

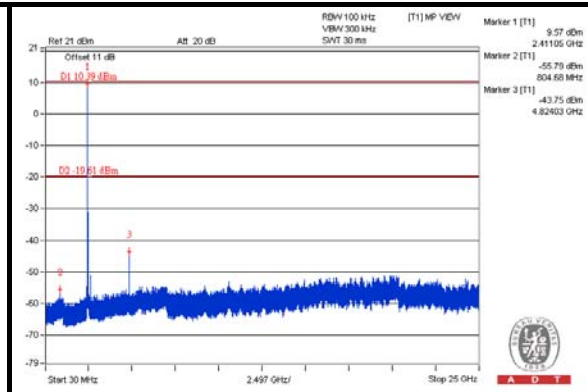
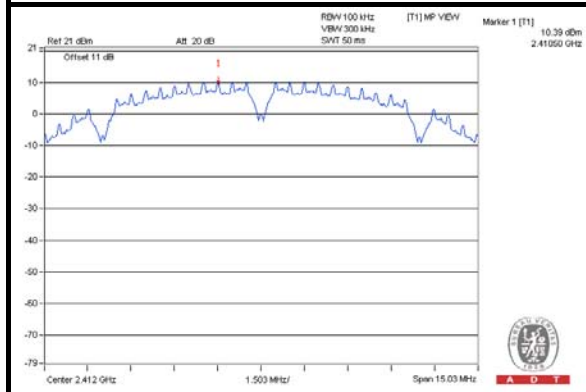

#### CH 6

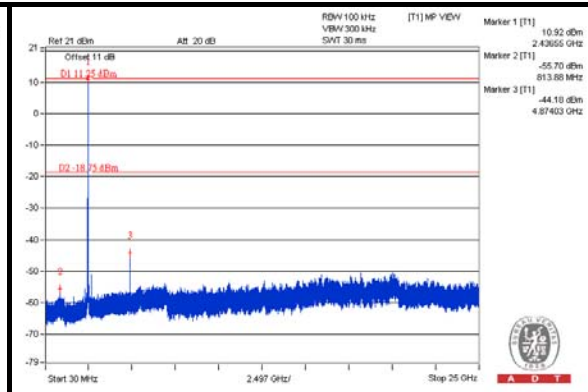
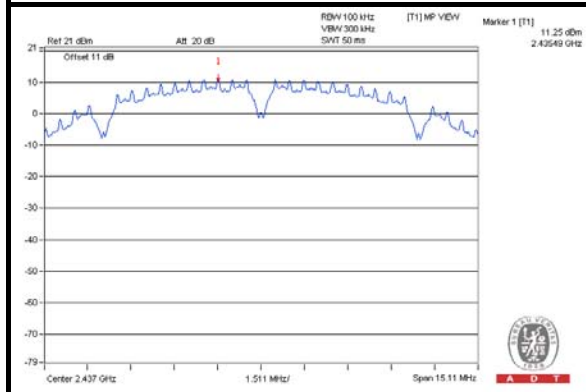

#### CH 11

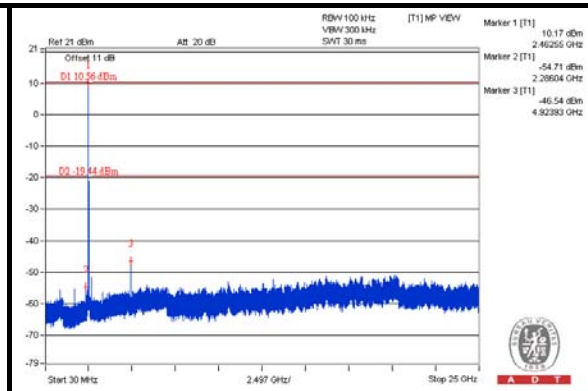
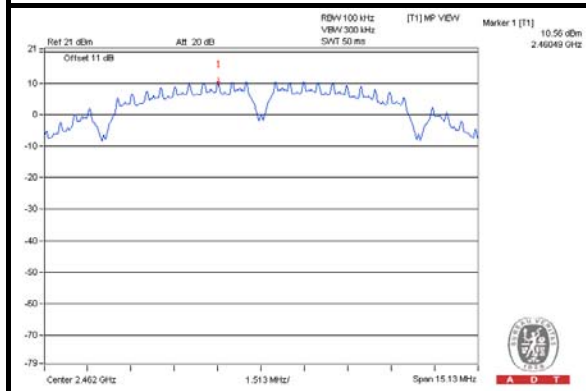

#### CH 1 Band edge

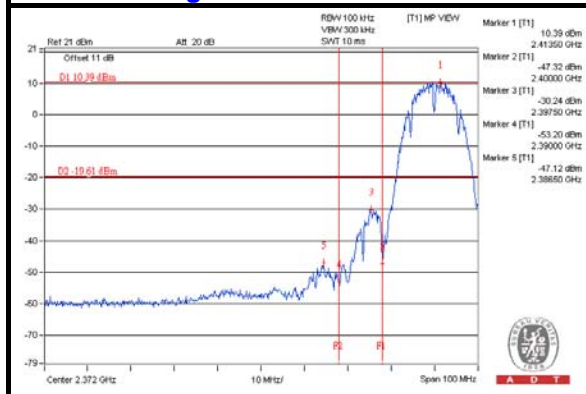

#### CH 11 Band edge

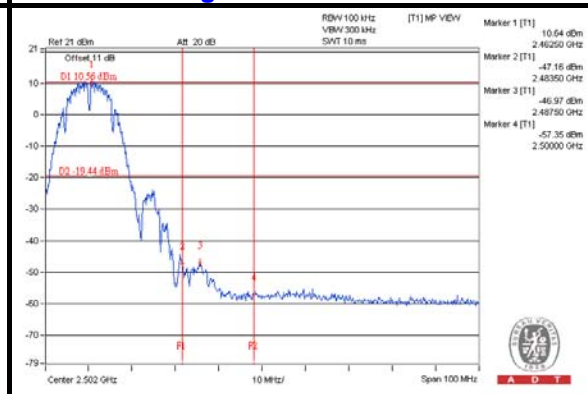





A D T

# 802.11g CHAIN 0

## CH 1

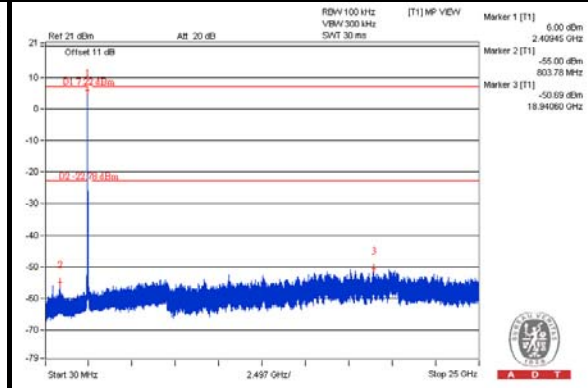
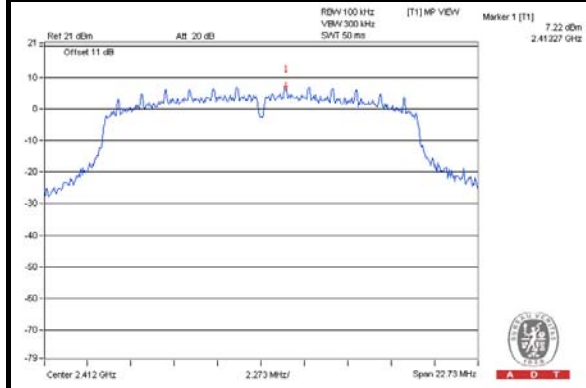

## CH 6

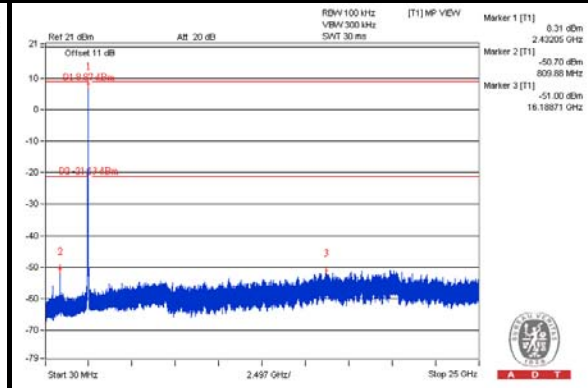
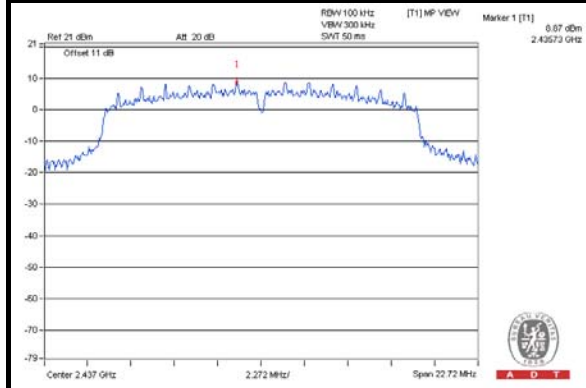

## CH 11

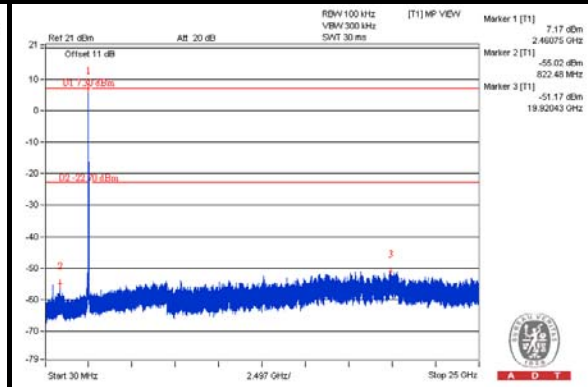
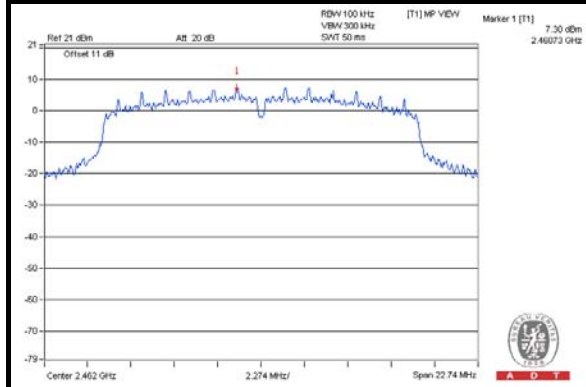

## CH 1 Band edge

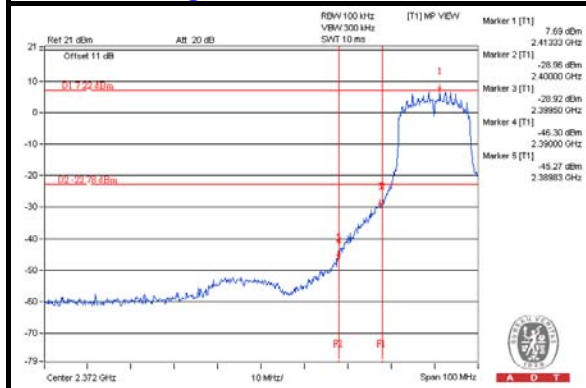

## CH 11 Band edge

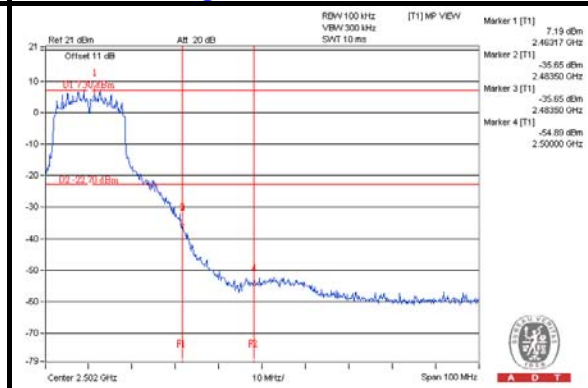



A D T

### CHAIN 1

#### CH 1

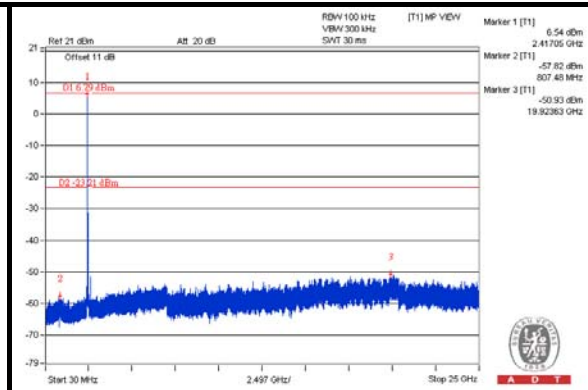
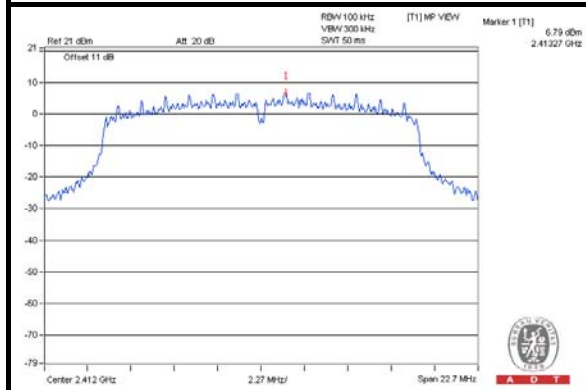

#### CH 6

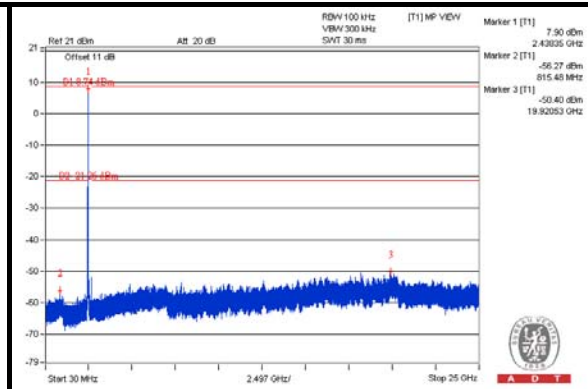
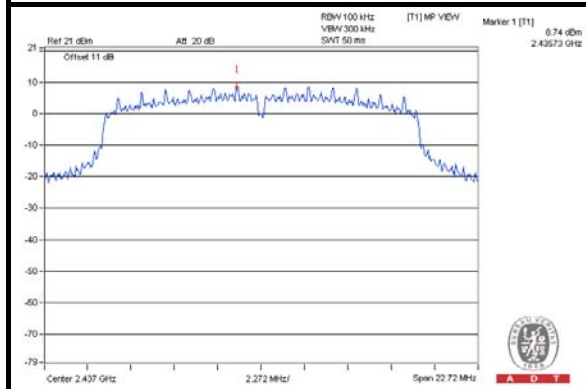

#### CH 11

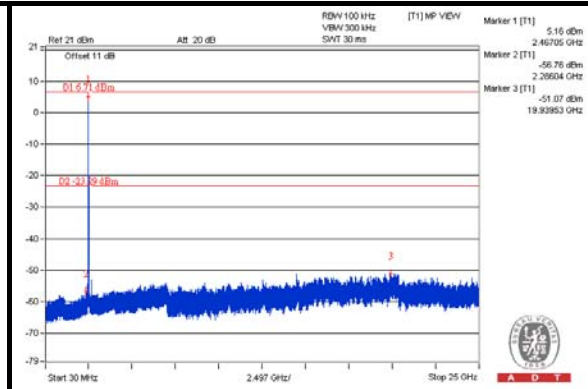
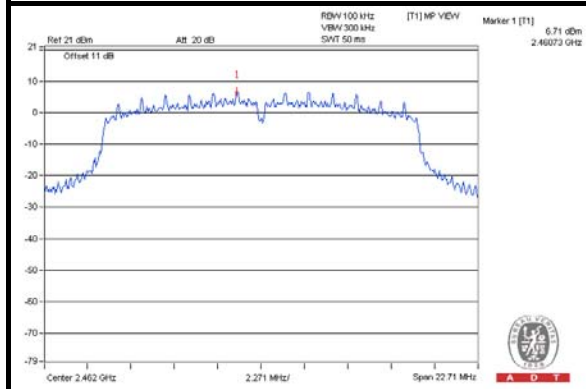

#### CH 1 Band edge

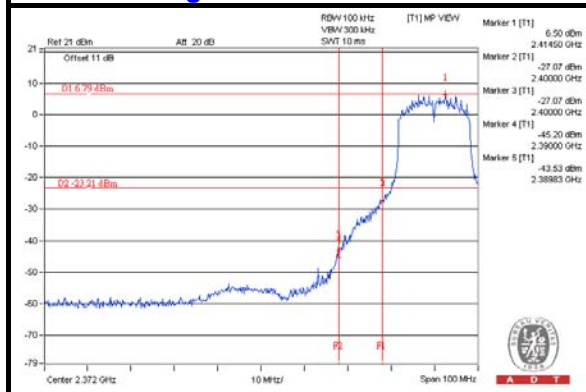

#### CH 11 Band edge

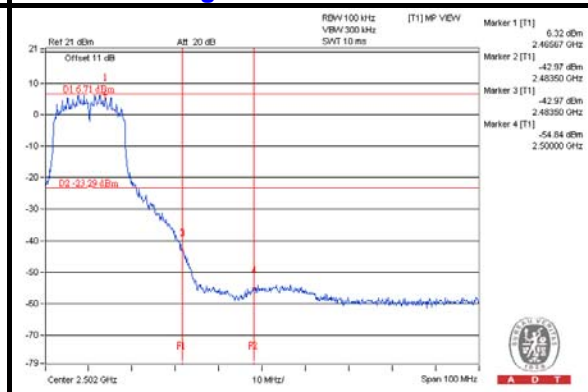



A D T

# 802.11n (20MHz) CHAIN 0

## CH 1

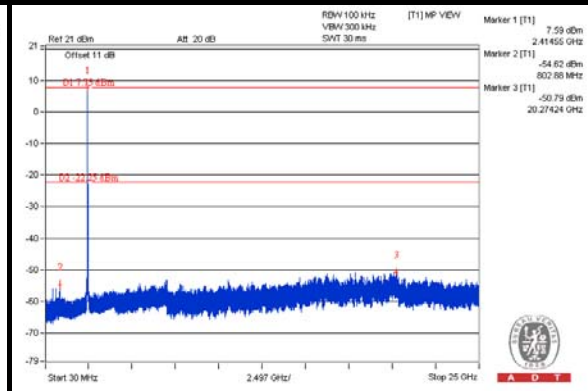
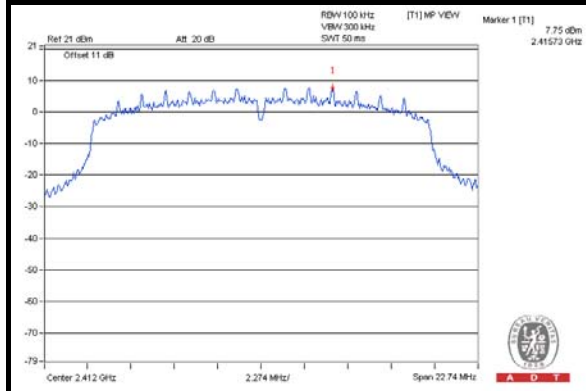

## CH 6

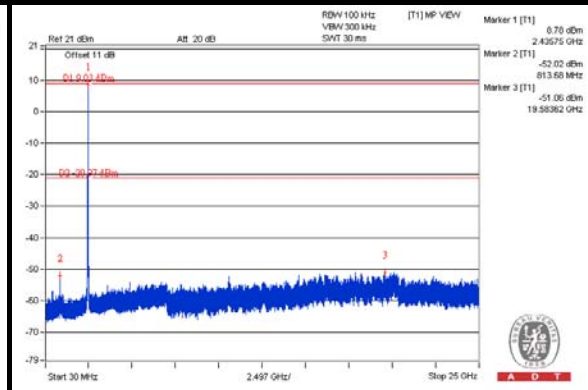
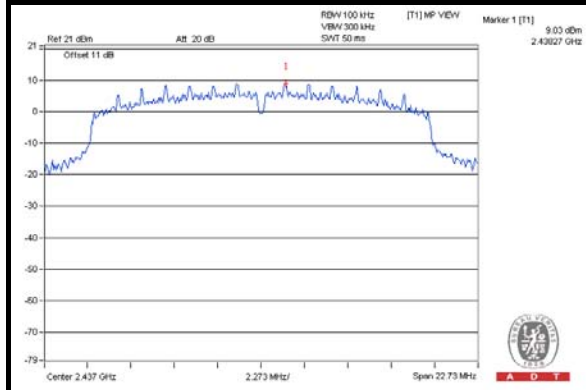

## CH 11

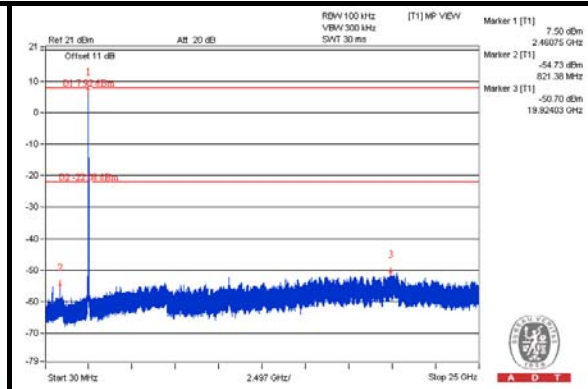
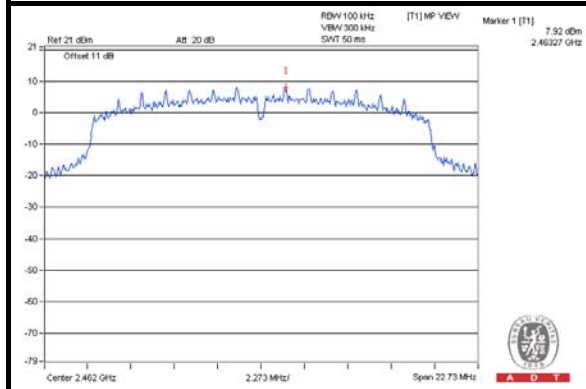

## CH 1 Band edge

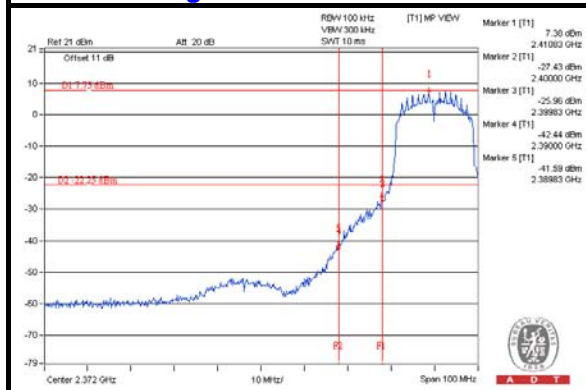

## CH 11 Band edge

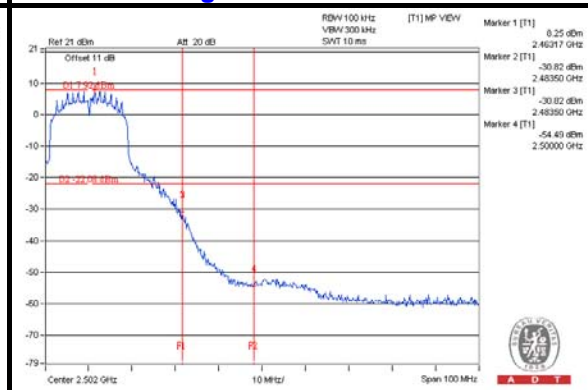



A D T

### CHAIN 1

#### CH 1

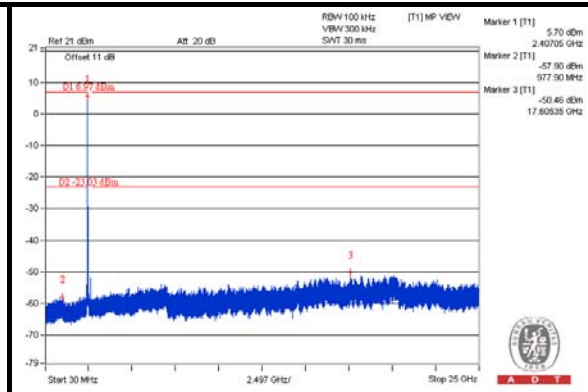
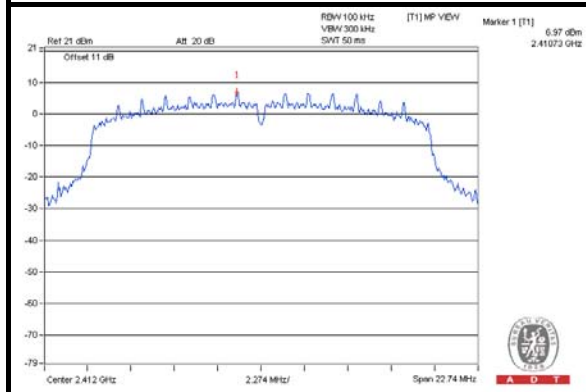

#### CH 6

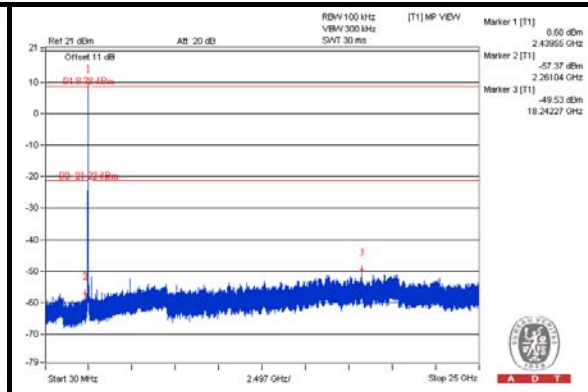
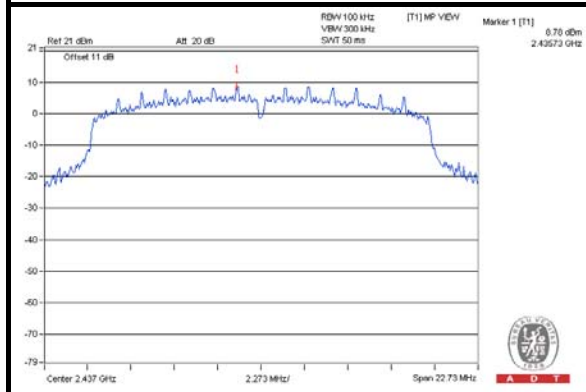

#### CH 11

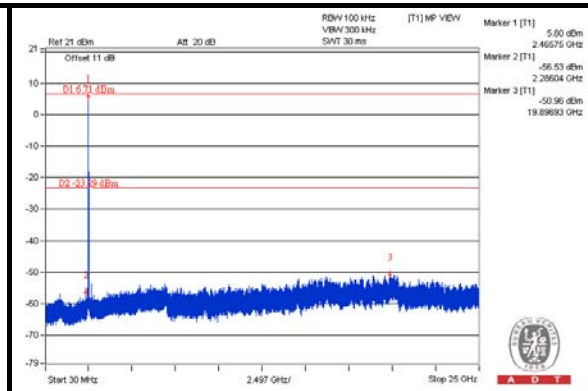
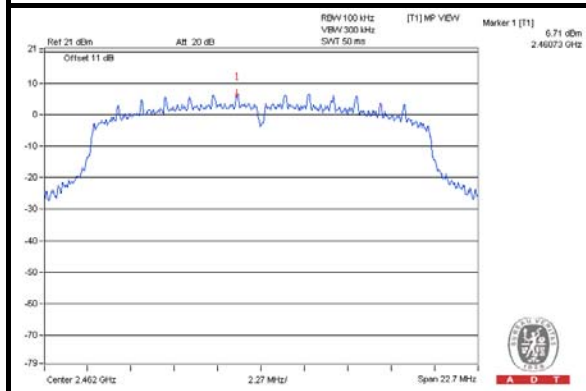

#### CH 1 Band edge

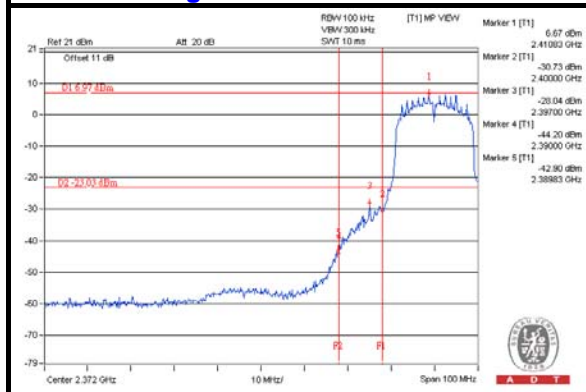

#### CH 11 Band edge

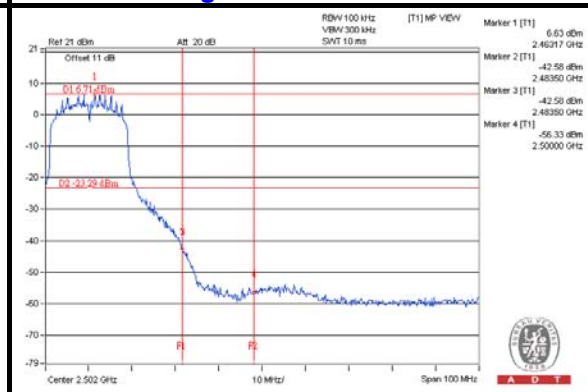



A D T

### 802.11n (40MHz) CHAIN 0

#### CH 3

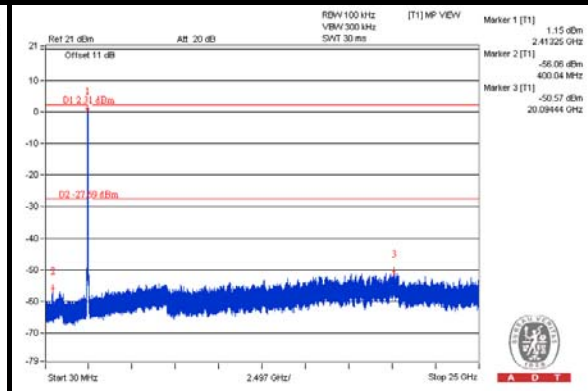
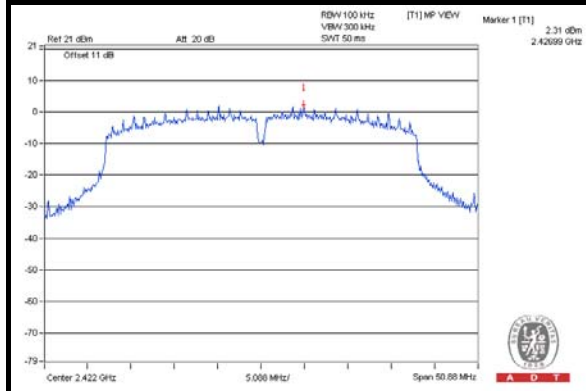

#### CH 6

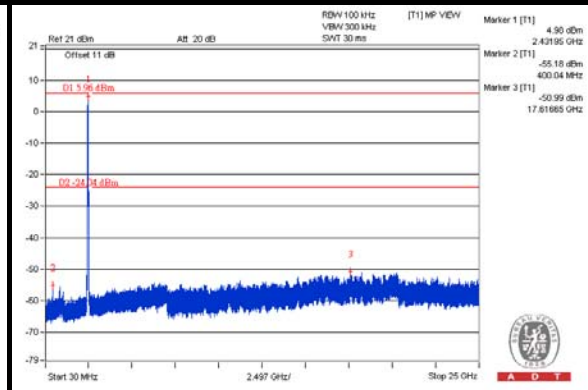
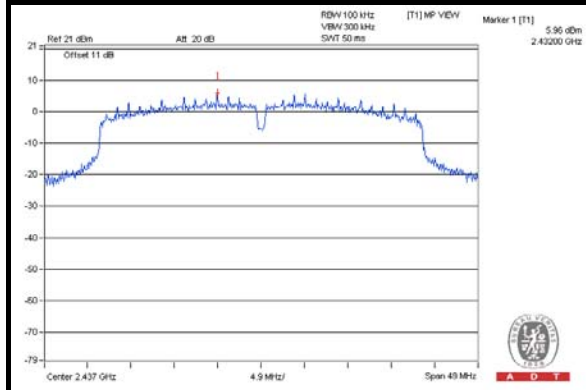

#### CH 9

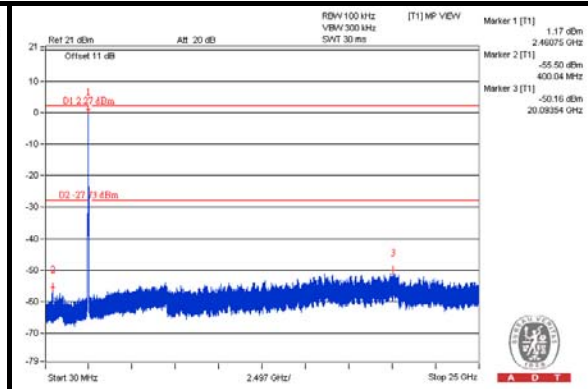
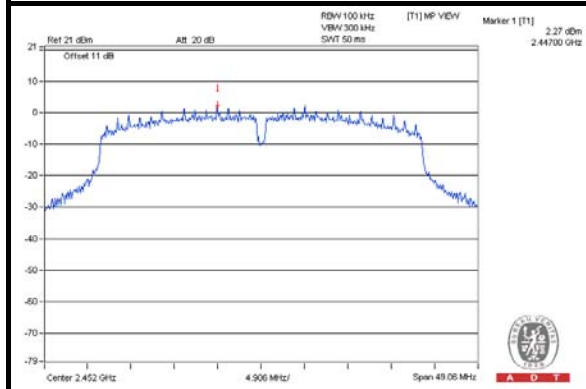

#### CH 3 Band edge

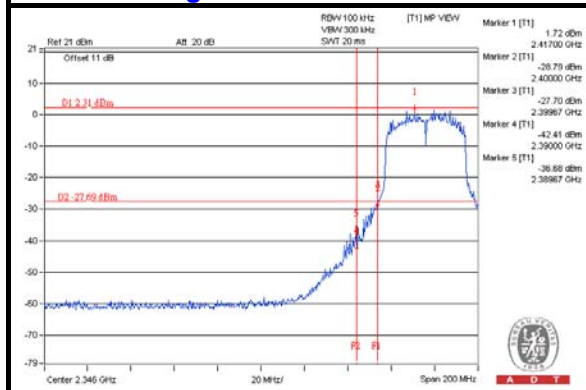

#### CH 9 Band edge

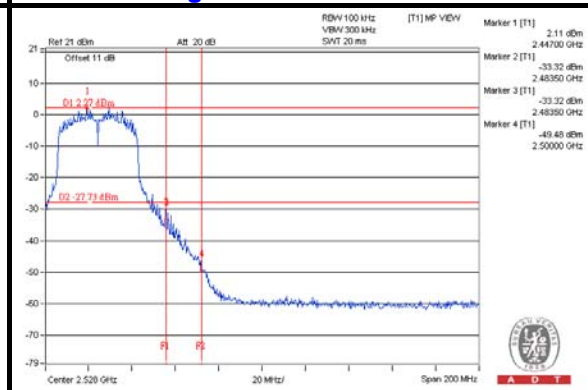



A D T

### CHAIN 1

#### CH 3

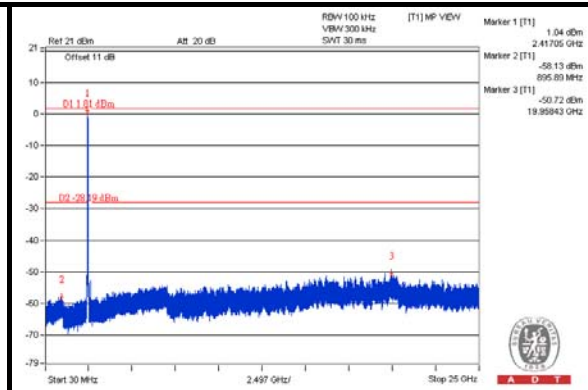
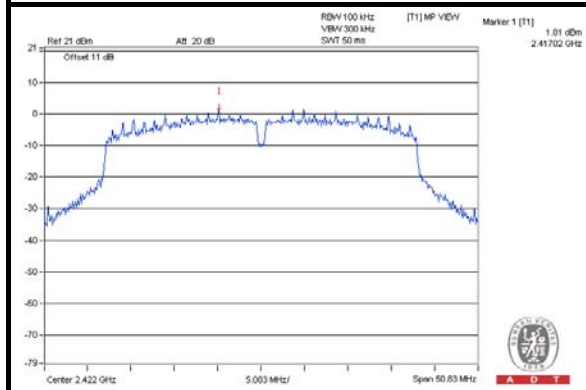

#### CH 6

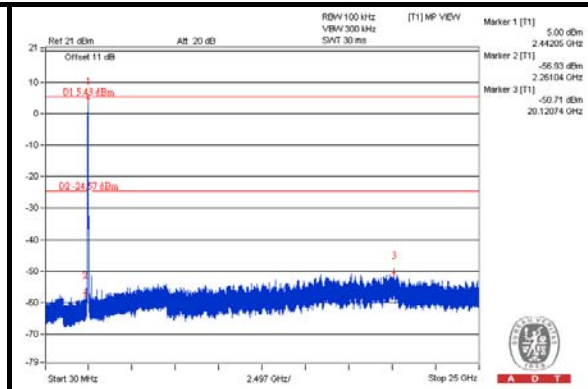
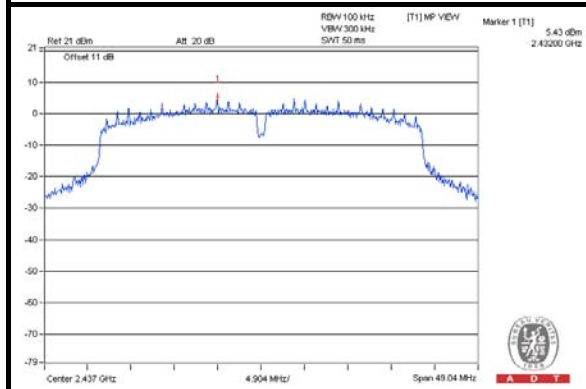

#### CH 9

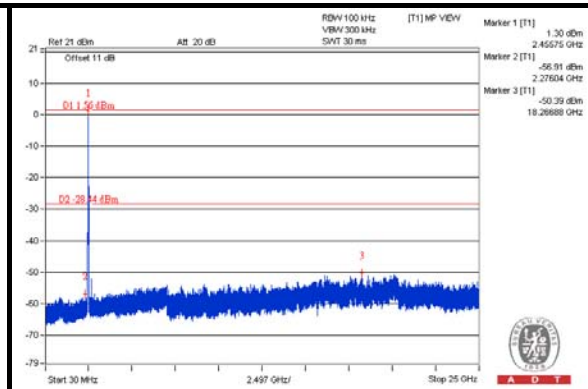
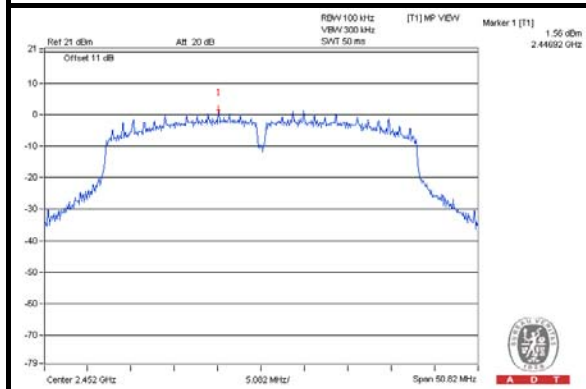

#### CH 3 Band edge

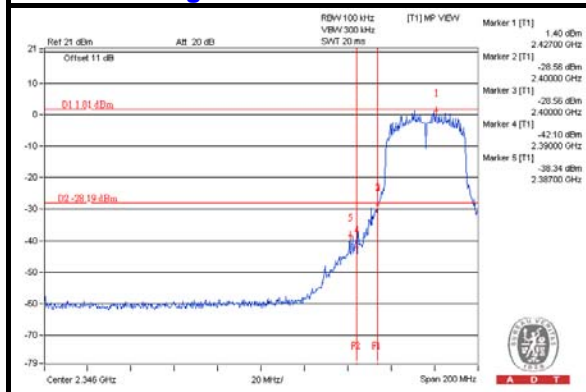

#### CH 9 Band edge

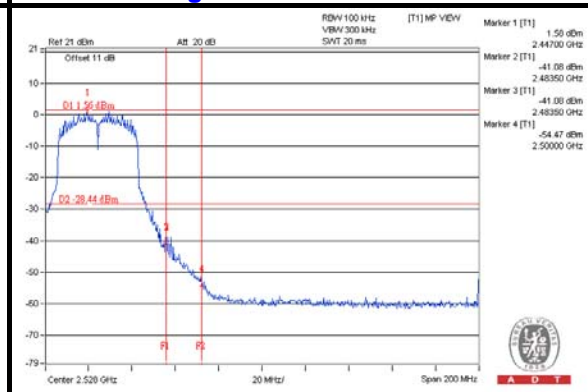



## 5. PHOTOGRAPHS OF THE TEST CONFIGURATION

Please refer to the attached file (Test Setup Photo).



## 6. INFORMATION ON THE TESTING LABORATORIES

We, Bureau Veritas Consumer Products Services (H.K.) Ltd., Taoyuan Branch, were founded in 1988 to provide our best service in EMC, Radio, Telecom and Safety consultation. Our laboratories are accredited and approved according to ISO/IEC 17025.

If you have any comments, please feel free to contact us at the following:

**Linko EMC/RF Lab:**

Tel: 886-2-26052180

Fax: 886-2-26051924

**Hsin Chu EMC/RF/ Telecom Lab:**

Tel: 886-3-5935343

Fax: 886-3-5935342

**Hwa Ya EMC/RF/Safety Lab:**

Tel: 886-3-3183232

Fax: 886-3-3270892

**Email:** [service.adt@tw.bureauveritas.com](mailto:service.adt@tw.bureauveritas.com)

**Web Site:** [www.bureauveritas-adt.com](http://www.bureauveritas-adt.com)

The address and road map of all our labs can be found in our web site also.





A D T

## **7. APPENDIX A – MODIFICATIONS RECORDERS FOR ENGINEERING CHANGES TO THE EUT BY THE LAB**

No any modifications were made to the EUT by the lab during the test.

**---END---**