

FCC Test Report

Report No.: RF190220C23-1

FCC ID: KA2BA2820PA1

Test Model: DBA-2820P

Received Date: Apr. 24, 2018

Test Date: May 04 ~ Jul. 08, 2018
Mar. 08 ~ Mar. 19, 2019

Issued Date: Mar. 20, 2019

Applicant: D-Link Corporation

Address: 17595 Mt. Herrmann, Fountain Valley, California, United States, 92708

Issued By: Bureau Veritas Consumer Products Services (H.K.) Ltd., Taoyuan Branch

Lab Address: No. 47-2, 14th Ling, Chia Pau Vil., Lin Kou Dist., New Taipei City, Taiwan, R.O.C.

Test Location: No. 19, Hwa Ya 2nd Rd., Wen Hwa Vil., Kwei Shan Dist., Taoyuan City 33383, TAIWAN (R.O.C.)

**FCC Registration /
Designation Number:** 788550 / TW0003



This report is for your exclusive use. Any copying or replication of this report to or for any other person or entity, or use of our name or trademark, is permitted only with our prior written permission. This report sets forth our findings solely with respect to the test samples identified herein. The results set forth in this report are not indicative or representative of the quality or characteristics of the lot from which a test sample was taken or any similar or identical product specifically and expressly noted. Our report includes all of the tests requested by you and the results thereof based upon the information that you provided to us. You have 60 days from date of issuance of this report to notify us of any material error or omission caused by our negligence, provided, however, that such notice shall be in writing and shall specifically address the issue you wish to raise. A failure to raise such issue within the prescribed time shall constitute your unqualified acceptance of the completeness of this report, the tests conducted and the correctness of the report contents. Unless specific mention, the uncertainty of measurement has been explicitly taken into account to declare the compliance or non-compliance to the specification. The report must not be used by the client to claim product certification, approval, or endorsement by TAF or any government agencies.

Table of Contents

Release Control Record	4
1 Certificate of Conformity	5
2 Summary of Test Results	6
2.1 Measurement Uncertainty	6
2.2 Modification Record	6
3 General Information	7
3.1 General Description of EUT	7
3.2 Description of Test Modes	9
3.2.1 Test Mode Applicability and Tested Channel Detail	10
3.3 Duty Cycle of Test Signal	12
3.4 Description of Support Units	13
3.4.1 Configuration of System under Test	13
3.5 General Description of Applied Standards	14
4 Test Types and Results	15
4.1 Radiated Emission and Bandedge Measurement.....	15
4.1.1 Limits of Radiated Emission and Bandedge Measurement	15
4.1.2 Test Instruments	16
4.1.3 Test Procedures.....	18
4.1.4 Deviation from Test Standard	19
4.1.5 Test Set Up	19
4.1.6 EUT Operating Conditions.....	20
4.1.7 Test Results	21
4.2 Conducted Emission Measurement	46
4.2.1 Limits of Conducted Emission Measurement	46
4.2.2 Test Instruments	46
4.2.3 Test Procedures.....	47
4.2.4 Deviation from Test Standard	47
4.2.5 Test Setup.....	47
4.2.6 EUT Operating Conditions.....	47
4.2.7 Test Results	48
4.3 Transmit Power Measurement	54
4.3.1 Limits of Transmit Power Measurement	54
4.3.2 Test Setup.....	54
4.3.3 Test Instruments	55
4.3.4 Test Procedure	55
4.3.5 Deviation from Test Standard	55
4.3.6 EUT Operating Conditions.....	55
4.3.7 Test Result.....	56
4.4 Occupied Bandwidth Measurement	61
4.4.1 Test Setup.....	61
4.4.2 Test Instruments	61
4.4.3 Test Procedure	61
4.4.4 Test Result.....	62
4.5 Peak Power Spectral Density Measurement	64
4.5.1 Limits of Peak Power Spectral Density Measurement	64
4.5.2 Test Setup.....	64
4.5.3 Test Instruments	64
4.5.4 Test Procedures.....	65
4.5.5 Deviation from Test Standard	65
4.5.6 EUT Operating Conditions.....	65
4.5.7 Test Results	66
4.6 Frequency Stability.....	73
4.6.1 Limits of Frequency Stability Measurement	73

4.6.2 Test Setup.....	73
4.6.3 Test Instruments	73
4.6.4 Test Procedure	73
4.6.5 Deviation from Test Standard	73
4.6.6 EUT Operating Condition	74
4.6.7 Test Results	74
4.7 6dB Bandwidth Measurement.....	75
4.7.1 Limits of 6dB Bandwidth Measurement.....	75
4.7.2 Test Setup.....	75
4.7.3 Test Instruments	75
4.7.4 Test Procedure	75
4.7.5 Deviation from Test Standard	75
4.7.6 EUT Operating Condition	75
4.7.7 Test Results	76
5 Pictures of Test Arrangements.....	78
Annex A- Radiated Out of Band Emission (OOBE) Measurement (For U-NII-3 band).....	79
Appendix – Information of the Testing Laboratories	83

Release Control Record

Issue No.	Description	Date Issued
RF190220C23-1	Original release.	Mar. 20, 2019

1 Certificate of Conformity

Product: Nuclias Cloud-Managed AC2600 Wave 2 Access Point

Brand: D-Link Corporation

Test Model: DBA-2820P

Sample Status: Engineering sample

Applicant: D-Link Corporation

Test Date: May 04 ~ Jul. 08, 2018
Mar. 08 ~ Mar. 19, 2019

Standards: 47 CFR FCC Part 15, Subpart E (Section 15.407)
ANSI C63.10:2013

The above equipment has been tested by **Bureau Veritas Consumer Products Services (H.K.) Ltd., Taoyuan Branch**, and found compliance with the requirement of the above standards. The test record, data evaluation & Equipment Under Test (EUT) configurations represented herein are true and accurate accounts of the measurements of the sample's RF characteristics under the conditions specified in this report.

Prepared by :

Polly Chien / Specialist

Date:

Mar. 20, 2019

Approved by :



Bruce Chen / Project Engineer

Date:

Mar. 20, 2019

2 Summary of Test Results

47 CFR FCC Part 15, Subpart E (Section 15.407)			
FCC Clause	Test Item	Result	Remarks
15.407(b)(6)	AC Power Conducted Emissions	Pass	Meet the requirement of limit. Minimum passing margin is -10.34dB at 0.31400MHz.
15.407(b)(1/2/3/4(i/ii)/6)	Radiated Emissions & Band Edge Measurement	Pass	Meet the requirement of limit. Minimum passing margin is -1.1dB at 5150.00MHz & 5650.00MHz.
15.407(a)(1/2/3)	Max Average Transmit Power	Pass	Meet the requirement of limit.
---	Occupied Bandwidth Measurement	Pass	Meet the requirement of limit.
15.407(a)(1/2/3)	Peak Power Spectral Density	Pass	Meet the requirement of limit.
15.407(e)	6dB bandwidth	Pass	Meet the requirement of limit. (U-NII-3 Band only)
15.407(g)	Frequency Stability	Pass	Meet the requirement of limit.
15.203	Antenna Requirement	Pass	Antenna connector is I-PEX not a standard connector.

*For U-NII-3 band compliance with rule part 15.407(b)(4)(i), the OOB test plots were recorded in Annex A.
Note:

Determining compliance based on the results of the compliance measurement, not taking into account measurement instrumentation uncertainty.

2.1 Measurement Uncertainty

Where relevant, the following measurement uncertainty levels have been estimated for tests performed on the EUT as specified in CISPR 16-4-2:

Measurement	Frequency	Expanded Uncertainty (k=2) (\pm)
Conducted Emissions at mains ports	150kHz ~ 30MHz	2.94 dB
Radiated Emissions up to 1 GHz	9kHz ~ 30MHz	3.04 dB
	30MHz ~ 200MHz	3.86 dB
	200MHz ~ 1000MHz	3.87 dB
Radiated Emissions above 1 GHz	1GHz ~ 18GHz	2.29 dB
	18GHz ~ 40GHz	2.29 dB

2.2 Modification Record

There were no modifications required for compliance.

3 General Information

3.1 General Description of EUT

Product	Nuclias Cloud-Managed AC2600 Wave 2 Access Point
Brand	D-Link Corporation
Test Model	DBA-2820P
Status of EUT	Engineering sample
Power Supply Rating	12Vdc (From adapter) 54Vdc (From PoE)
Modulation Type	256QAM, 64QAM, 16QAM, QPSK, BPSK
Modulation Technology	OFDM
Transfer Rate	802.11a: 54/48/36/24/18/12/9/6Mbps 802.11n: up to 600Mbps 802.11ac: up to 1733.3Mbps
Operating Frequency	5180~5240MHz, 5745~5825MHz
Number of Channel	5180~5240MHz: 802.11a, 802.11n (HT20), 802.11ac (VHT20): 4 802.11n (HT40), 802.11ac (VHT40): 2 802.11ac (VHT80): 1 5745~5825MHz: 802.11a, 802.11n (HT20), 802.11ac (VHT20): 5 802.11n (HT40), 802.11ac (VHT40): 2 802.11ac (VHT80): 1 For 802.11ac (VHT80+VHT80): 5180~5240MHz & 5745~5825MHz: 802.11ac (VHT80+VHT80): 1
Output Power	CDD Mode: 5180~5240MHz: 693.300mW 5745~5825MHz: 924.279mW Beamforming Mode: 5180~5240MHz: 504.569mW 5745~5825MHz: 656.044mW
Antenna Type	Refer to Note
Antenna Connector	Refer to Note
Accessory Device	Adapter
Cable Supplied	NA

Note:

1. This report is issued as a supplementary report to BV CPS report no. RF180424C01-1. The differences compared to the original report are changing the outer casing, model, product name and updating FW. Therefore, test item for conducted, radiated emissions below 1GHz and radiated emissions above 1GHz on 802.11n (HT40): CH 46 and 802.11n (HT20): CH149 had been re-tested and the other test data was kept.

2. The EUT incorporates a MIMO function. Physically, the EUT provides 4 completed transmitter and 4 receivers.

Modulation Mode	Beamforming Mode	TX Function	Available Channel
802.11a	Not Support	4TX	36 ~ 48, 149 ~ 165
802.11n (HT20)	Support	4TX	36 ~ 48, 149 ~ 165
802.11n (HT40)	Support	4TX	38 ~ 46, 151 ~ 159
802.11ac (VHT20)	Support	4TX	36 ~ 48, 149 ~ 165
802.11ac (VHT40)	Support	4TX	38 ~ 46, 151 ~ 159
802.11ac (VHT80)	Support	4TX	42, 155
802.11ac (VHT80+ VHT80)	Not Support	2TX+2TX	42 + 155

* The modulation and bandwidth are similar for 802.11n mode for HT20/HT40 and 802.11ac mode for VHT20/VHT40. After pre-testing, 802.11ac (VHT20/VHT40) power is lower than 802.11n (HT20/HT40), therefore 802.11n (HT20/HT40) is the worst case to representative mode in test report. (Final test mode refer section 3.2.1)

3. The EUT uses following antennas.

Ant. No.	Type	Connector	Ant. Gain (dBi)	
			2.4GHz	5GHz
0, 1, 2, 3	PIFA	I-PEX	3	4

*The antenna is cross-polarized antenna.

4. The EUT consumes power from the following Adapters and PoE.

Adapter 1	
Brand	Channel Well Technology
Model	2ABL030F NJ
Input Power	100-240Vac~, 50/60Hz 1.0A
Output Power	12.0Vdc / 2.5A
Power Cord	1.2m non-shielded power cord without core

Adapter 2	
Brand	Asian Power Devices Inc.
Model	WA-30J12R
Input Power	100-240Vac~, 50-60Hz, 0.9A Max
Output Power	12Vdc / 2.5A
Power Cord	1.2m non-shielded power cord without core

PoE (Support unit)	
Brand	LEADER ELECTRONICS INC.
Model	NU90-J540167-11
Input Power	100-240Vac~, 50-60Hz, 1.2A
Output Power	54Vdc / 1.67A

3.2 Description of Test Modes

5180 ~ 5240MHz:

4 channels are provided for 802.11a, 802.11n (HT20), 802.11ac (VHT20):

Channel	Frequency	Channel	Frequency
36	5180 MHz	44	5220 MHz
40	5200 MHz	48	5240 MHz

2 channels are provided for 802.11n (HT40), 802.11ac (VHT40):

Channel	Frequency	Channel	Frequency
38	5190 MHz	46	5230 MHz

1 channel is provided for 802.11ac (VHT80):

Channel	Frequency
42	5210MHz

5745 ~ 5825MHz:

5 channels are provided for 802.11a, 802.11n (HT20), 802.11ac (VHT20):

Channel	Frequency	Channel	Frequency
149	5745MHz	161	5805MHz
153	5765MHz	165	5825MHz
157	5785MHz		

2 channels are provided for 802.11n (HT40), 802.11ac (VHT40):

Channel	Frequency	Channel	Frequency
151	5755MHz	159	5795MHz

1 channel is provided for 802.11ac (VHT80):

Channel	Frequency
155	5775MHz

For 802.11ac (VHT80+VHT80):

5180~5240MHz & 5745~5825MHz:

1 channel is provided for 802.11ac (VHT80+VHT80):

Channel	Frequency
42+155	5210MHz+5775MHz

3.2.1 Test Mode Applicability and Tested Channel Detail

EUT CONFIGURE MODE	APPLICABLE TO				DESCRIPTION
	RE \geq 1G	RE<1G	PLC	APCM	
A	√	√	√	√	Power from adapter 1
B	-	√	√	-	Power from adapter 2
C	-	√	√	-	Power from PoE

Where **RE \geq 1G**: Radiated Emission above 1GHz & Bandedge Measurement
RE<1G: Radiated Emission below 1GHz
PLC: Power Line Conducted Emission
APCM: Antenna Port Conducted Measurement

Note:

1. The EUT had been pre-tested on the positioned of each 3 axis. The worst case was found when positioned on **Z-plane**.
2. "-": Means no effect.

Radiated Emission Test (Above 1GHz):

- Pre-Scan has been conducted to determine the worst-case mode from all possible combinations between available modulations, data rates and antenna ports (if EUT with antenna diversity architecture).
- Following channel(s) was (were) selected for the final test as listed below.

EUT Configure Mode	Mode	Frequency Band (MHz)	Available Channel	Tested Channel	Modulation Technology	Data Rate (Mbps)
A	802.11a	5180-5240	36 to 48	36, 40, 48	OFDM	6.0
A	802.11n (HT20)		36 to 48	36, 40, 48	OFDM	7.2
A	802.11n (HT40)		38 to 46	38, 46	OFDM	15.0
A	802.11ac (VHT80)		42	42	OFDM	130.0
A	802.11a	5745-5825	149 to 165	149, 157, 165	OFDM	6.0
A	802.11n (HT20)		149 to 165	149, 157, 165	OFDM	7.2
A	802.11n (HT40)		151 to 159	151, 159	OFDM	15.0
A	802.11ac (VHT80)		155	155	OFDM	130.0
A	802.11ac (VHT80+VHT80)	5180-5240	42	42+155	OFDM	130.0
A		5745-5825	155		OFDM	130.0

Radiated Emission Test (Below 1GHz):

- Pre-Scan has been conducted to determine the worst-case mode from all possible combinations between available modulations, data rates and antenna ports (if EUT with antenna diversity architecture).
- Following channel(s) was (were) selected for the final test as listed below.

EUT Configure Mode	Mode	Frequency Band (MHz)	Available Channel	Tested Channel	Modulation Technology	Data Rate (Mbps)
A, B, C	802.11a	5180-5240	36 to 48	157	OFDM	6.0
		5745-5825	149 to 165		OFDM	6.0

Power Line Conducted Emission Test:

- Pre-Scan has been conducted to determine the worst-case mode from all possible combinations between available modulations, data rates and antenna ports (if EUT with antenna diversity architecture).
- Following channel(s) was (were) selected for the final test as listed below.

EUT Configure Mode	Mode	Frequency Band (MHz)	Available Channel	Tested Channel	Modulation Technology	Data Rate (Mbps)
A, B, C	802.11a	5180-5240	36 to 48	157	OFDM	6.0
		5745-5825	149 to 165		OFDM	6.0

Antenna Port Conducted Measurement:

- This item includes all test value of each mode, but only includes spectrum plot of worst value of each mode.
- Pre-Scan has been conducted to determine the worst-case mode from all possible combinations between available modulations, data rates and antenna ports (if EUT with antenna diversity architecture).
- Following channel(s) was (were) selected for the final test as listed below.

EUT Configure Mode	Mode	Frequency Band (MHz)	Available Channel	Tested Channel	Modulation Technology	Data Rate (Mbps)
A	802.11a	5180-5240	36 to 48	36, 40, 48	OFDM	6.0
A	802.11n (HT20)		36 to 48	36, 40, 48	OFDM	7.2
A	802.11n (HT40)		38 to 46	38, 46	OFDM	15.0
A	802.11ac (VHT80)		42	42	OFDM	130.0
A	802.11a	5745-5825	149 to 165	149, 157, 165	OFDM	6.0
A	802.11n (HT20)		149 to 165	149, 157, 165	OFDM	7.2
A	802.11n (HT40)		151 to 159	151, 159	OFDM	15.0
A	802.11ac (VHT80)		155	155	OFDM	130.0
A	802.11ac (VHT80+VHT80)	5180-5240	42	42+155	OFDM	130.0
A		5745-5825	155		OFDM	130.0

Test Condition:

APPLICABLE TO	ENVIRONMENTAL CONDITIONS	INPUT POWER	TESTED BY
RE\geq1G	25deg. C, 70%RH, 23deg. C, 68%RH	120Vac, 60Hz	Luis Lee, Willy Cheng
RE$<$1G	25deg. C, 67%RH, 23deg. C, 68%RH	120Vac, 60Hz	Adair Peng
	23deg. C, 68%RH	54Vdc	Willy Cheng
PLC	25deg. C, 75%RH	120Vac, 60Hz	Jones Chang
	22deg. C, 66%RH	54Vdc	Adair Peng
APCM	25deg. C, 60%RH	120Vac, 60Hz	Alan Wu

3.3 Duty Cycle of Test Signal

Duty cycle of test signal is > 98%, duty factor is not required

Duty cycle of test signal is < 98 %, duty factor is required

802.11a: Duty cycle = 2.055/2.132 = 0.964, Duty factor = $10 * \log(1/0.964) = 0.16$

802.11n (HT20): Duty cycle = 4.995/5.080 = 0.983

802.11n (HT40): Duty cycle = 2.410/2.520 = 0.956, Duty factor = $10 * \log(1/0.956) = 0.19$

802.11ac (VHT80): Duty cycle = 1.144/1.219 = 0.938, Duty factor = $10 * \log(1/0.938) = 0.28$

802.11ac (VHT80+VHT80): Duty cycle = 1.144/1.219 = 0.938, Duty factor = $10 * \log(1/0.938) = 0.28$

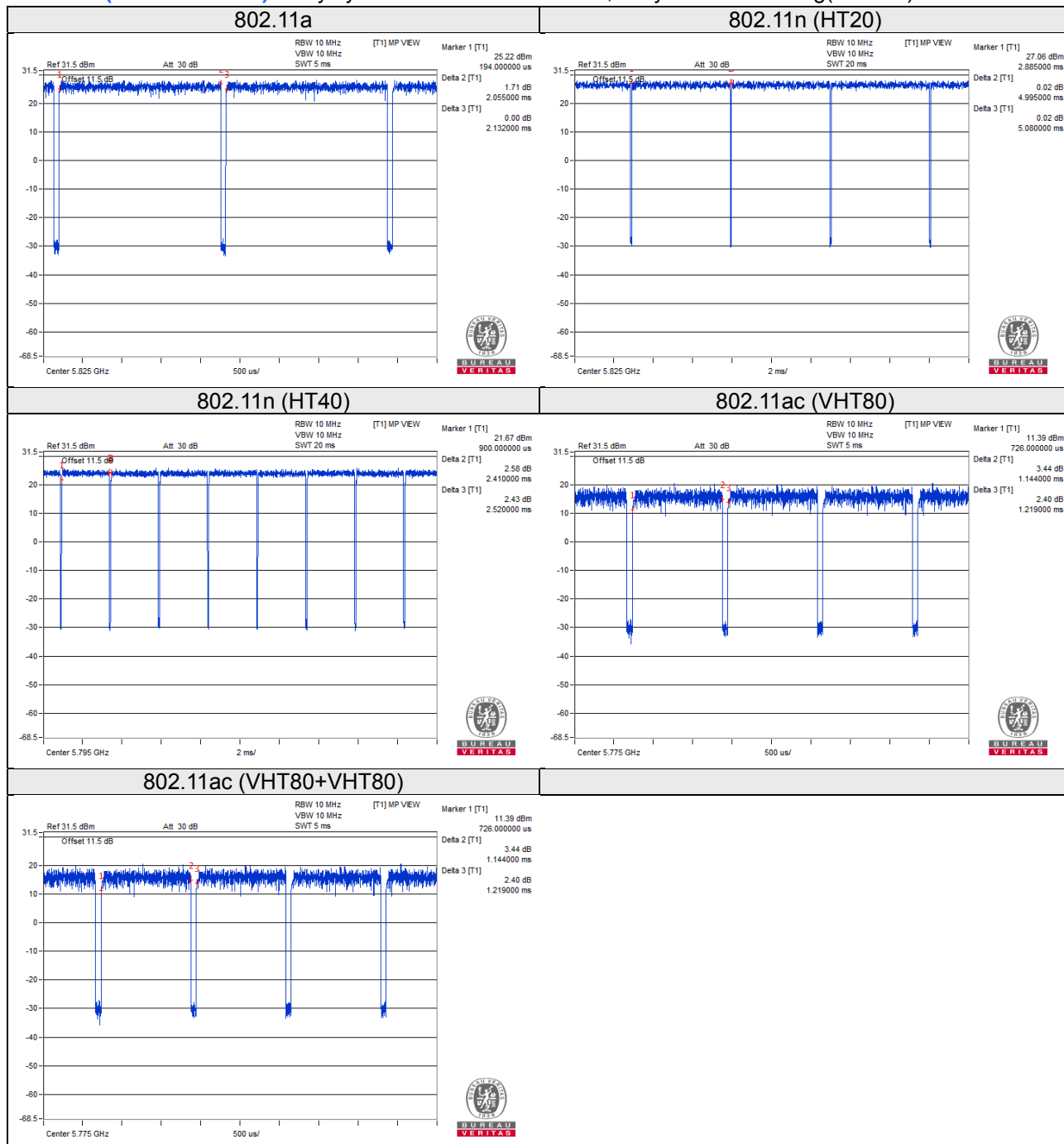

3.4 Description of Support Units

The EUT has been tested as an independent unit together with other necessary accessories or support units. The following support units or accessories were used to form a representative test configuration during the tests.

ID	Product	Brand	Model No.	Serial No.	FCC ID	Remarks
A.	Notebook	DELL	E5410	1HC2XM1	FCC DoC Approved	-
B.	Load	NA	NA	NA	NA	-
C.	PoE	LEADER ELECTRONI CS INC.	NU90-J540167-I1	NA	NA	Provided by client

Note:

1. All power cords of the above support units are non-shielded (1.8m).
2. Item A acted as a communication partner to transfer data.

ID	Descriptions	Qty.	Length (m)	Shielding (Yes/No)	Cores (Qty.)	Remarks
1.	RJ45 cable	1	1.5	N	0	Cat5e
2.	RJ45 cable	1	5	N	0	Cat5e
3.	RJ45 to console cable	1	1.2	N	0	Cat5e
4.	RJ45, Cat5e	1	1.8	N	0	-

3.4.1 Configuration of System under Test

Mode A, B

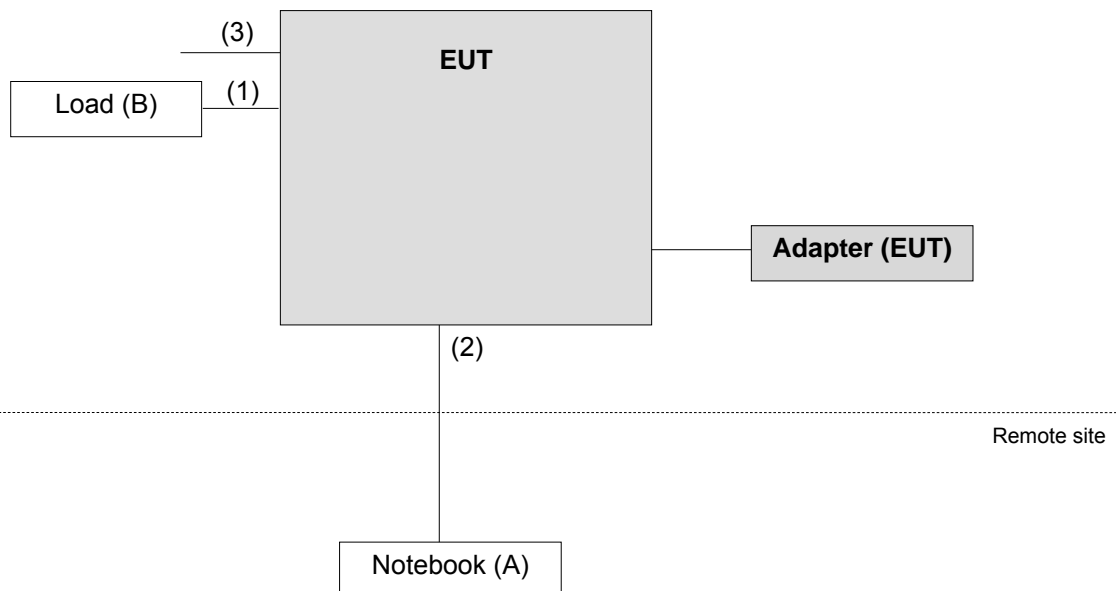

Mode C

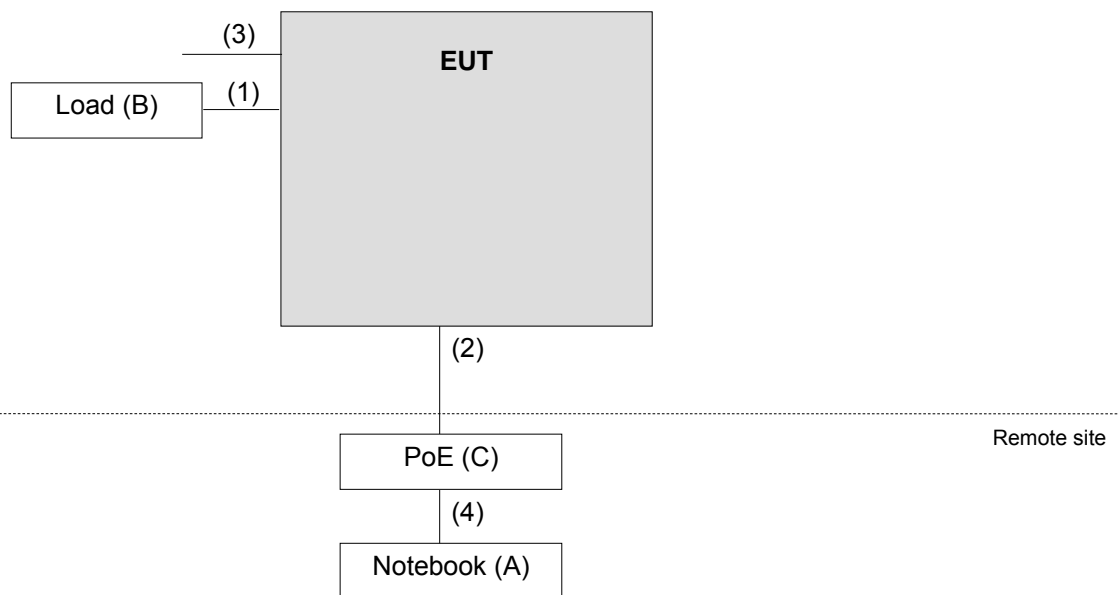

3.5 General Description of Applied Standards

The EUT is a RF Product. According to the specifications of the manufacturer, it must comply with the requirements of the following standards:

FCC Part 15, Subpart E (15.407)

KDB 789033 D02 General UNII Test Procedure New Rules v02r01

KDB 662911 D01 Multiple Transmitter Output v02r01

ANSI C63.10:2013

All test items have been performed and recorded as per the above standards.

4 Test Types and Results

4.1 Radiated Emission and Bandedge Measurement

4.1.1 Limits of Radiated Emission and Bandedge Measurement

Radiated emissions which fall in the restricted bands must comply with the radiated emission limits specified as below table.

Frequencies (MHz)	Field Strength (microvolts/meter)	Measurement Distance (meters)
0.009 ~ 0.490	2400/F(kHz)	300
0.490 ~ 1.705	24000/F(kHz)	30
1.705 ~ 30.0	30	30
30 ~ 88	100	3
88 ~ 216	150	3
216 ~ 960	200	3
Above 960	500	3

NOTE:

- The lower limit shall apply at the transition frequencies.
- Emission level (dBuV/m) = 20 log Emission level (uV/m).
- For frequencies above 1000MHz, the field strength limits are based on average detector, however, the peak field strength of any emission shall not exceed the maximum permitted average limits, specified above by more than 20dB under any condition of modulation.

Limits of unwanted emission out of the restricted bands

Applicable To		Limit	
789033 D02 General UNII Test Procedure New Rules v02r01		Field Strength at 3m	
		PK: 74 (dBµV/m)	AV: 54 (dBµV/m)
Frequency Band	Applicable To	EIRP Limit	Equivalent Field Strength at 3m
5150~5250 MHz	15.407(b)(1)	PK: -27 (dBm/MHz)	PK: 68.2(dBµV/m)
5250~5350 MHz	15.407(b)(2)		
5470~5725 MHz	15.407(b)(3)		
5725~5850 MHz	<input checked="" type="checkbox"/> 15.407(b)(4)(i)	PK: -27 (dBm/MHz) ^{*1} PK: 10 (dBm/MHz) ^{*2} PK: 15.6 (dBm/MHz) ^{*3} PK: 27 (dBm/MHz) ^{*4}	PK: 68.2(dBµV/m) ^{*1} PK: 105.2 (dBµV/m) ^{*2} PK: 110.8(dBµV/m) ^{*3} PK: 122.2 (dBµV/m) ^{*4}
	<input type="checkbox"/> 15.407(b)(4)(ii)	Emission limits in section 15.247(d)	
^{*1} beyond 75 MHz or more above of the band edge. ^{*3} below the band edge increasing linearly to a level of 15.6 dBm/MHz at 5 MHz above.		^{*2} below the band edge increasing linearly to 10 dBm/MHz at 25 MHz above. ^{*4} from 5 MHz above or below the band edge increasing linearly to a level of 27 dBm/MHz at the band edge.	

Note: The following formula is used to convert the equipment isotropic radiated power (eirp) to field strength:

$$E = \frac{1000000 \sqrt{30P}}{3} \mu\text{V/m, where P is the eirp (Watts).}$$

4.1.2 Test Instruments

Tested date: May 04 ~ Jul. 08, 2018

Description & Manufacturer	Model No.	Serial No.	Date of Calibration	Due Date of Calibration
Test Receiver ROHDE & SCHWARZ	ESCI	100424	Oct. 17, 2017	Oct. 16, 2018
Spectrum Analyzer ROHDE & SCHWARZ	FSP40	100041	Dec. 12, 2017	Dec. 11, 2018
BILOG Antenna SCHWARZBECK	VULB9168	9168-171	Dec. 11, 2017	Dec. 10, 2018
HORN Antenna SCHWARZBECK	9120D	209	Dec. 13, 2017	Dec. 12, 2018
HORN Antenna SCHWARZBECK	BBHA 9170	BBHA9170241	Dec. 01, 2017	Nov. 30, 2018
Loop Antenna EMCI	EM-6879	269	Aug. 11, 2017	Aug. 10, 2018
Preamplifier Agilent (Below 1GHz)	8447D	2944A10738	Aug. 21, 2017	Aug. 20, 2018
Preamplifier Agilent (Above 1GHz)	8449B	3008A02465	Apr. 03, 2018	Apr. 02, 2019
RF signal cable HUBER+SUHNER	SUCOFLEX 104	Cable-CH3-03 (223653/4)	Aug. 21, 2017	Aug. 20, 2018
RF signal cable HUBER+SUHNER& EMCI	SUCOFLEX 104&EMC104-SM- SM-8000	Cable-CH3-03 (309224+170907)	Sep.11, 2017	Sep. 10, 2018
Software BV ADT	ADT_Radiated_ V7.6.15.9.5	NA	NA	NA
Antenna Tower inn-co GmbH	MA 4000	013303	NA	NA
Antenna Tower Controller BV ADT	AT100	AT93021702	NA	NA
Turn Table BV ADT	TT100	TT93021702	NA	NA
Turn Table Controller BV ADT	SC100	SC93021702	NA	NA
Boresight Antenna Fixture	FBA-01	FBA-SIP01	NA	NA
High Speed Peak Power Meter	ML2495A	0824012	Aug. 18, 2017	Aug. 17, 2018
Power Sensor	MA2411B	0738171	Aug. 18, 2017	Aug. 17, 2018
26GHz ~ 40GHz Amplifier Agilent	8449B	3008A1960	Aug. 08, 2017	Aug. 07, 2018

Note: 1. The calibration interval of the above test instruments is 12 months and the calibrations are traceable to NML/ROC and NIST/USA.
2. The test was performed in HwaYa Chamber 3.

Tested date: Mar. 08 ~ Mar. 19, 2019

Description & Manufacturer	Model No.	Serial No.	Date of Calibration	Due Date of Calibration
Test Receiver ROHDE & SCHWARZ	ESIB7	100187	May 29, 2018	May 28, 2019
BILOG Antenna SCHWARZBECK	VULB9168	9168-171	Nov. 22, 2018	Nov. 21, 2019
HORN Antenna SCHWARZBECK	9120D	209	Nov. 25, 2018	Nov. 24, 2019
HORN Antenna SCHWARZBECK	BBHA 9170	BBHA9170241	Nov. 25, 2018	Nov. 24, 2019
HORN Antenna SCHWARZBECK	BBHA 9170	BBHA9170241	Dec. 01, 2017	Nov. 30, 2018
Loop Antenna TESEQ	HLA 6121	45745	Jun. 14, 2018	Jun. 13, 2019
Preamplifier Agilent (Below 1GHz)	8447D	2944A10738	Aug. 21, 2018	Aug. 20, 2019
Preamplifier Agilent (Above 1GHz)	8449B	3008A02465	Apr. 03, 2018	Apr. 02, 2019
RF signal cable HUBER+SUHNER	SUCOFLEX 104	Cable-CH3-03 (223653/4)	Aug. 21, 2018	Aug. 20, 2019
RF signal cable HUBER+SUHNER& EMCI	SUCOFLEX 104&EMC104-SM- SM-8000	Cable-CH3-03 (309224+170907)	Aug. 21, 2018	Aug. 20, 2019
Software BV ADT	ADT_Radiated_ V7.6.15.9.5	NA	NA	NA
Antenna Tower inn-co GmbH	MA 4000	013303	NA	NA
Antenna Tower Controller BV ADT	AT100	AT93021702	NA	NA
Turn Table BV ADT	TT100	TT93021702	NA	NA
Turn Table Controller BV ADT	SC100	SC93021702	NA	NA
Boresight Antenna Fixture	FBA-01	FBA-SIP01	NA	NA

Note: 1. The calibration interval of the above test instruments is 12 months and the calibrations are traceable to NML/ROC and NIST/USA.
 2. The test was performed in HwaYa Chamber 3.

4.1.3 Test Procedures

For Radiated emission below 30MHz

- a. The EUT was placed on the top of a rotating table 0.8 meters above the ground at a 3 meter chamber room. The table was rotated 360 degrees to determine the position of the highest radiation.
- b. The EUT was set 3 meters away from the interference-receiving antenna, which was mounted on the top of a variable-height antenna tower.
- c. Parallel, perpendicular, and ground-parallel orientations of the antenna are set to make the measurement.
- d. For each suspected emission, the EUT was arranged to its worst case and the rotatable table was turned from 0 degrees to 360 degrees to find the maximum reading.
- e. The test-receiver system was set to Quasi-Peak Detect Function and Specified Bandwidth with Maximum Hold Mode.

Note:

1. The resolution bandwidth and video bandwidth of test receiver/spectrum analyzer is 9kHz at frequency below 30MHz.

For Radiated emission above 30MHz

- a. The EUT was placed on the top of a rotating table 0.8 meters (for 30MHz ~ 1GHz) / 1.5 meters (for above 1GHz) above the ground at 3 meter chamber room for test. The table was rotated 360 degrees to determine the position of the highest radiation.
- b. The EUT was set 3 meters away from the interference-receiving antenna, which was mounted on the top of a variable-height antenna tower.
- c. The height of antenna is varied from one meter to four meters above the ground to determine the maximum value of the field strength. Both horizontal and vertical polarizations of the antenna are set to make the measurement.
- d. For each suspected emission, the EUT was arranged to its worst case and then the antenna was tuned to heights from 1 meter to 4 meters and the rotatable table was turned from 0 degrees to 360 degrees to find the maximum reading.
- e. The test-receiver system was set to quasi-peak detect function and specified bandwidth with maximum hold mode when the test frequency is below 1 GHz.
- f. The test-receiver system was set to peak and average detect function and specified bandwidth with maximum hold mode when the test frequency is above 1 GHz. If the peak reading value also meets average limit, measurement with the average detector is unnecessary.

Note:

1. The resolution bandwidth and video bandwidth of test receiver/spectrum analyzer is 120kHz for Quasi-peak detection (QP) at frequency below 1GHz.
2. The resolution bandwidth of test receiver/spectrum analyzer is 1 MHz and the video bandwidth is 3 MHz for Peak detection (PK) at frequency above 1GHz.
3. The resolution bandwidth of test receiver/spectrum analyzer is 1MHz and the video bandwidth is $\geq 1/T$ (Duty cycle < 98%) or 10Hz (Duty cycle $\geq 98\%$) for Average detection (AV) at frequency above 1GHz.
4. All modes of operation were investigated and the worst-case emissions are reported.

4.1.4 Deviation from Test Standard

No deviation.

4.1.5 Test Set Up

For Radiated emission below 30MHz

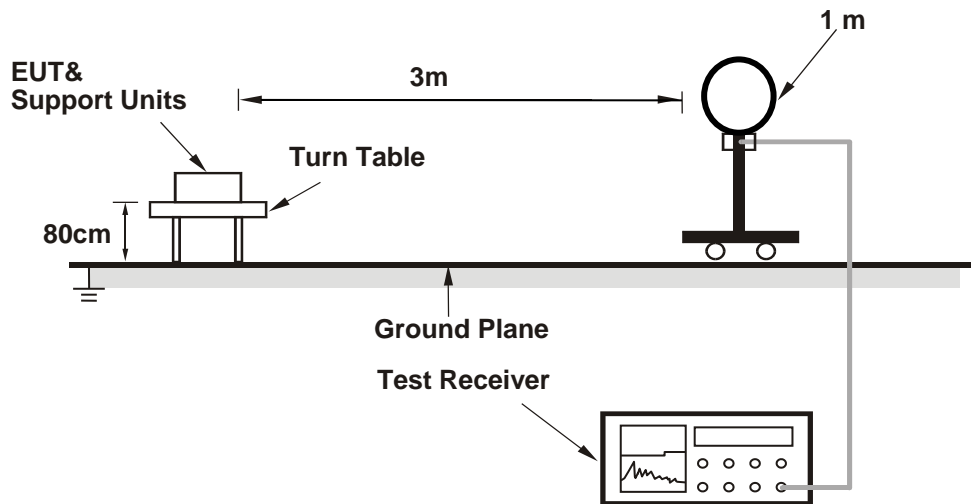

For Radiated emission 30MHz to 1GHz

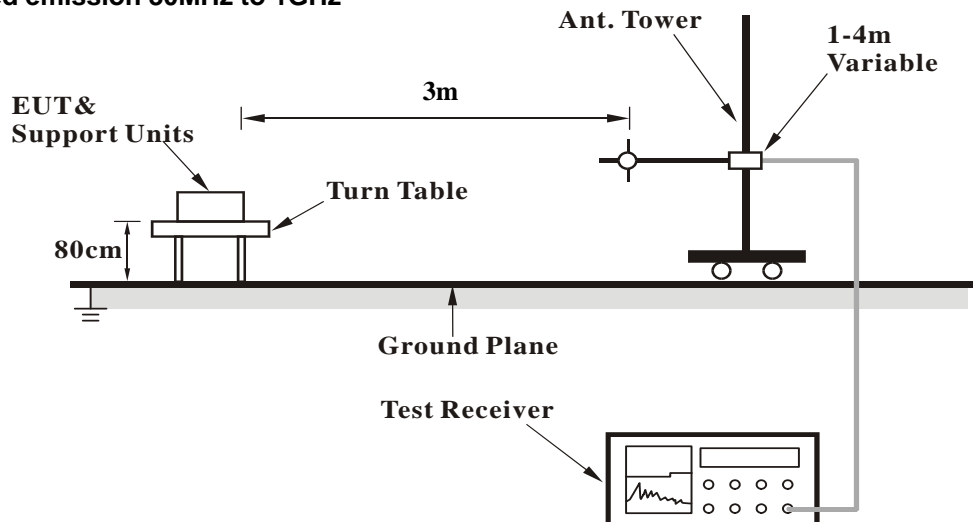

For Radiated emission above 1GHz

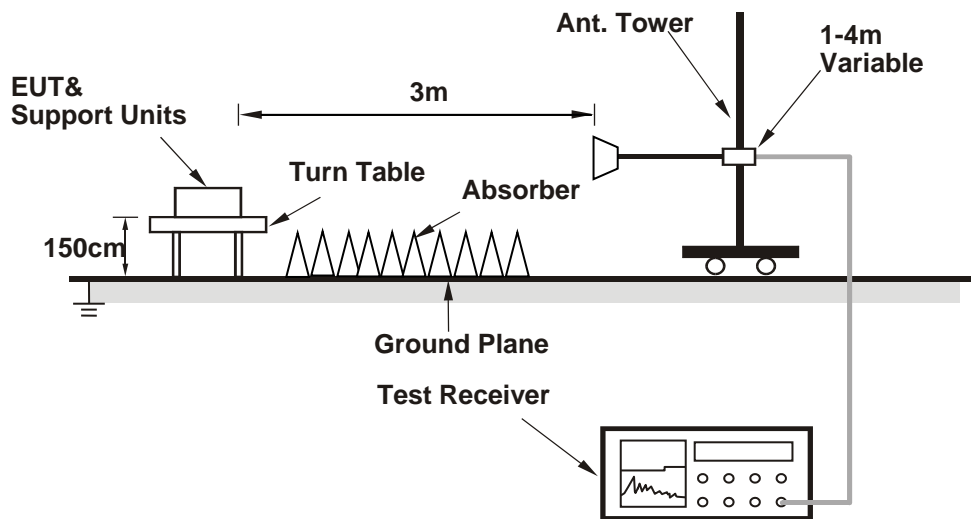

For the actual test configuration, please refer to the attached file (Test Setup Photo).

4.1.6 EUT Operating Conditions

- Placed the EUT on the testing table.
- Prepared a notebook to act as a communication partner and placed it outside of testing area.
- The communication partner connected with EUT via a RJ45 cable and ran a test program (QRCT 3.0.239.0) to enable EUT under transmission condition continuously at specific channel frequency.
- The necessary accessories enable the system in full functions.

4.1.7 Test Results

Above 1GHz data:

802.11a

CHANNEL	TX Channel 36	DETECTOR	Peak (PK)
FREQUENCY RANGE	1GHz ~ 40GHz	FUNCTION	Average (AV)

ANTENNA POLARITY & TEST DISTANCE: HORIZONTAL AT 3 M								
NO.	FREQ. (MHz)	EMISSION LEVEL (dBuV/m)	LIMIT (dBuV/m)	MARGIN (dB)	ANTENNA HEIGHT (m)	TABLE ANGLE (Degree)	RAW VALUE (dBuV)	CORRECTION FACTOR (dB/m)
1	5150.00	66.3 PK	74.0	-7.7	1.52 H	306	62.40	3.90
2	5150.00	52.4 AV	54.0	-1.6	1.52 H	306	48.50	3.90
3	*5180.00	121.1 PK			1.54 H	278	81.50	39.60
4	*5180.00	110.4 AV			1.54 H	278	70.80	39.60
5	#10360.00	58.4 PK	74.0	-15.6	2.55 H	152	42.60	15.80
6	#10360.00	45.1 AV	54.0	-8.9	2.55 H	152	29.30	15.80
ANTENNA POLARITY & TEST DISTANCE: VERTICAL AT 3 M								
NO.	FREQ. (MHz)	EMISSION LEVEL (dBuV/m)	LIMIT (dBuV/m)	MARGIN (dB)	ANTENNA HEIGHT (m)	TABLE ANGLE (Degree)	RAW VALUE (dBuV)	CORRECTION FACTOR (dB/m)
1	5150.00	67.6 PK	74.0	-6.4	4.00 V	2	63.70	3.90
2	5150.00	52.1 AV	54.0	-1.9	4.00 V	2	48.20	3.90
3	*5180.00	120.9 PK			4.00 V	349	81.30	39.60
4	*5180.00	109.3 AV			4.00 V	349	69.70	39.60
5	#10360.00	58.3 PK	74.0	-15.7	2.32 V	126	42.50	15.80
6	#10360.00	44.9 AV	54.0	-9.1	2.32 V	126	29.10	15.80

Remarks:

1. Emission Level(dBuV/m) = Raw Value(dBuV) + Correction Factor(dB/m)
2. Correction Factor(dB/m) = Antenna Factor(dB/m) + Cable Factor(dB) – Pre-Amplifier Factor(dB)
3. The other emission levels were very low against the limit.
4. Margin value = Emission Level – Limit value
5. " * ": Fundamental frequency.
6. " # ": The radiated frequency is out of the restricted band.

CHANNEL	TX Channel 40	DETECTOR FUNCTION	Peak (PK)
FREQUENCY RANGE	1GHz ~ 40GHz		Average (AV)

ANTENNA POLARITY & TEST DISTANCE: HORIZONTAL AT 3 M

NO.	FREQ. (MHz)	EMISSION LEVEL (dBuV/m)	LIMIT (dBuV/m)	MARGIN (dB)	ANTENNA HEIGHT (m)	TABLE ANGLE (Degree)	RAW VALUE (dBuV)	CORRECTION FACTOR (dB/m)
1	5150.00	68.1 PK	74.0	-5.9	1.52 H	306	64.20	3.90
2	5150.00	51.7 AV	54.0	-2.3	1.52 H	306	47.80	3.90
3	*5200.00	124.8 PK			1.90 H	55	85.20	39.60
4	*5200.00	113.8 AV			1.90 H	55	74.20	39.60
5	#10400.00	58.4 PK	74.0	-15.6	1.84 H	231	42.50	15.90
6	#10400.00	44.9 AV	54.0	-9.1	1.84 H	231	29.00	15.90

ANTENNA POLARITY & TEST DISTANCE: VERTICAL AT 3 M

NO.	FREQ. (MHz)	EMISSION LEVEL (dBuV/m)	LIMIT (dBuV/m)	MARGIN (dB)	ANTENNA HEIGHT (m)	TABLE ANGLE (Degree)	RAW VALUE (dBuV)	CORRECTION FACTOR (dB/m)
1	5150.00	66.7 PK	74.0	-7.3	4.00 V	3	62.80	3.90
2	5150.00	50.9 AV	54.0	-3.1	4.00 V	3	47.00	3.90
3	*5200.00	121.6 PK			4.00 V	6	82.00	39.60
4	*5200.00	110.9 AV			4.00 V	6	71.30	39.60
5	#10400.00	58.0 PK	74.0	-16.0	2.13 V	184	42.10	15.90
6	#10400.00	44.7 AV	54.0	-9.3	2.13 V	184	28.80	15.90

Remarks:

1. Emission Level(dBuV/m) = Raw Value(dBuV) + Correction Factor(dB/m)
2. Correction Factor(dB/m) = Antenna Factor(dB/m) + Cable Factor(dB) – Pre-Amplifier Factor(dB)
3. The other emission levels were very low against the limit.
4. Margin value = Emission Level – Limit value
5. " * ": Fundamental frequency.
6. " # ": The radiated frequency is out of the restricted band.

CHANNEL	TX Channel 48	DETECTOR FUNCTION	Peak (PK)
FREQUENCY RANGE	1GHz ~ 40GHz		Average (AV)

ANTENNA POLARITY & TEST DISTANCE: HORIZONTAL AT 3 M

NO.	FREQ. (MHz)	EMISSION LEVEL (dBuV/m)	LIMIT (dBuV/m)	MARGIN (dB)	ANTENNA HEIGHT (m)	TABLE ANGLE (Degree)	RAW VALUE (dBuV)	CORRECTION FACTOR (dB/m)
1	*5240.00	125.2 PK			3.84 H	53	85.80	39.40
2	*5240.00	113.7 AV			3.84 H	53	74.30	39.40
3	5350.00	56.6 PK	74.0	-17.4	2.87 H	264	52.60	4.00
4	5350.00	43.2 AV	54.0	-10.8	2.87 H	264	39.20	4.00
5	#10480.00	59.1 PK	74.0	-14.9	2.56 H	214	42.40	16.70
6	#10480.00	45.5 AV	54.0	-8.5	2.56 H	214	28.80	16.70

ANTENNA POLARITY & TEST DISTANCE: VERTICAL AT 3 M

NO.	FREQ. (MHz)	EMISSION LEVEL (dBuV/m)	LIMIT (dBuV/m)	MARGIN (dB)	ANTENNA HEIGHT (m)	TABLE ANGLE (Degree)	RAW VALUE (dBuV)	CORRECTION FACTOR (dB/m)
1	*5240.00	121.9 PK			3.89 V	348	82.50	39.40
2	*5240.00	111.3 AV			3.89 V	348	71.90	39.40
3	5350.00	56.1 PK	74.0	-17.9	3.55 V	351	52.10	4.00
4	5350.00	43.3 AV	54.0	-10.7	3.55 V	351	39.30	4.00
5	#10480.00	58.5 PK	74.0	-15.5	2.86 V	238	41.80	16.70
6	#10480.00	45.4 AV	54.0	-8.6	2.86 V	238	28.70	16.70

Remarks:

1. Emission Level(dBuV/m) = Raw Value(dBuV) + Correction Factor(dB/m)
2. Correction Factor(dB/m) = Antenna Factor(dB/m) + Cable Factor(dB) – Pre-Amplifier Factor(dB)
3. The other emission levels were very low against the limit.
4. Margin value = Emission Level – Limit value
5. " * ": Fundamental frequency.
6. " # ": The radiated frequency is out of the restricted band.

CHANNEL	TX Channel 149	DETECTOR FUNCTION	Peak (PK)
FREQUENCY RANGE	1GHz ~ 40GHz		Average (AV)

ANTENNA POLARITY & TEST DISTANCE: HORIZONTAL AT 3 M

NO.	FREQ. (MHz)	EMISSION LEVEL (dBuV/m)	LIMIT (dBuV/m)	MARGIN (dB)	ANTENNA HEIGHT (m)	TABLE ANGLE (Degree)	RAW VALUE (dBuV)	CORRECTION FACTOR (dB/m)
1	#5648.80	59.6 PK	68.2	-8.6	2.34 H	310	55.00	4.60
2	*5745.00	124.1 PK			2.34 H	310	84.00	40.10
3	*5745.00	112.7 AV			2.34 H	310	72.60	40.10
4	#5947.20	58.8 PK	68.2	-9.4	2.34 H	310	53.60	5.20
5	11490.00	59.9 PK	74.0	-14.1	2.97 H	242	42.30	17.60
6	11490.00	46.6 AV	54.0	-7.4	2.97 H	242	29.00	17.60

ANTENNA POLARITY & TEST DISTANCE: VERTICAL AT 3 M

NO.	FREQ. (MHz)	EMISSION LEVEL (dBuV/m)	LIMIT (dBuV/m)	MARGIN (dB)	ANTENNA HEIGHT (m)	TABLE ANGLE (Degree)	RAW VALUE (dBuV)	CORRECTION FACTOR (dB/m)
1	#5636.00	57.4 PK	68.2	-10.8	3.61 V	23	52.90	4.50
2	*5745.00	121.1 PK			3.61 V	23	81.00	40.10
3	*5745.00	110.6 AV			3.61 V	23	70.50	40.10
4	#5928.80	57.9 PK	68.2	-10.3	3.61 V	23	52.70	5.20
5	11490.00	59.3 PK	74.0	-14.7	1.86 V	262	41.70	17.60
6	11490.00	45.9 AV	54.0	-8.1	1.86 V	262	28.30	17.60

Remarks:

1. Emission Level(dBuV/m) = Raw Value(dBuV) + Correction Factor(dB/m)
2. Correction Factor(dB/m) = Antenna Factor(dB/m) + Cable Factor(dB) – Pre-Amplifier Factor(dB)
3. The other emission levels were very low against the limit.
4. Margin value = Emission Level – Limit value
5. " * ": Fundamental frequency.
6. " # ": The radiated frequency is out of the restricted band.

CHANNEL	TX Channel 157	DETECTOR FUNCTION	Peak (PK)
FREQUENCY RANGE	1GHz ~ 40GHz		Average (AV)

ANTENNA POLARITY & TEST DISTANCE: HORIZONTAL AT 3 M

NO.	FREQ. (MHz)	EMISSION LEVEL (dBuV/m)	LIMIT (dBuV/m)	MARGIN (dB)	ANTENNA HEIGHT (m)	TABLE ANGLE (Degree)	RAW VALUE (dBuV)	CORRECTION FACTOR (dB/m)
1	#5640.80	57.5 PK	68.2	-10.7	2.53 H	312	53.00	4.50
2	*5785.00	123.6 PK			2.53 H	312	83.30	40.30
3	*5785.00	112.4 AV			2.53 H	312	72.10	40.30
4	#5961.60	58.9 PK	68.2	-9.3	2.53 H	312	53.70	5.20
5	11570.00	60.9 PK	74.0	-13.1	2.34 H	157	43.00	17.90
6	11570.00	47.6 AV	54.0	-6.4	2.34 H	157	29.70	17.90

ANTENNA POLARITY & TEST DISTANCE: VERTICAL AT 3 M

NO.	FREQ. (MHz)	EMISSION LEVEL (dBuV/m)	LIMIT (dBuV/m)	MARGIN (dB)	ANTENNA HEIGHT (m)	TABLE ANGLE (Degree)	RAW VALUE (dBuV)	CORRECTION FACTOR (dB/m)
1	#5636.00	56.8 PK	68.2	-11.4	3.72 V	23	52.30	4.50
2	*5785.00	121.4 PK			3.72 V	23	81.10	40.30
3	*5785.00	110.9 AV			3.72 V	23	70.60	40.30
4	#5962.40	58.4 PK	68.2	-9.8	3.72 V	23	53.20	5.20
5	11570.00	59.8 PK	74.0	-14.2	3.12 V	271	41.90	17.90
6	11570.00	47.1 AV	54.0	-6.9	3.12 V	271	29.20	17.90

Remarks:

1. Emission Level(dBuV/m) = Raw Value(dBuV) + Correction Factor(dB/m)
2. Correction Factor(dB/m) = Antenna Factor(dB/m) + Cable Factor(dB) – Pre-Amplifier Factor(dB)
3. The other emission levels were very low against the limit.
4. Margin value = Emission Level – Limit value
5. " * ": Fundamental frequency.
6. " # ": The radiated frequency is out of the restricted band.

CHANNEL	TX Channel 165	DETECTOR FUNCTION	Peak (PK)
FREQUENCY RANGE	1GHz ~ 40GHz		Average (AV)

ANTENNA POLARITY & TEST DISTANCE: HORIZONTAL AT 3 M								
NO.	FREQ. (MHz)	EMISSION LEVEL (dBuV/m)	LIMIT (dBuV/m)	MARGIN (dB)	ANTENNA HEIGHT (m)	TABLE ANGLE (Degree)	RAW VALUE (dBuV)	CORRECTION FACTOR (dB/m)
1	#5636.80	58.0 PK	68.2	-10.2	2.20 H	290	53.50	4.50
2	*5825.00	122.9 PK			2.20 H	290	82.40	40.50
3	*5825.00	111.9 AV			2.20 H	290	71.40	40.50
4	#5928.80	59.7 PK	68.2	-8.5	2.20 H	290	54.50	5.20
5	11650.00	60.2 PK	74.0	-13.8	2.31 H	264	42.70	17.50
6	11650.00	46.9 AV	54.0	-7.1	2.31 H	264	29.40	17.50
ANTENNA POLARITY & TEST DISTANCE: VERTICAL AT 3 M								
NO.	FREQ. (MHz)	EMISSION LEVEL (dBuV/m)	LIMIT (dBuV/m)	MARGIN (dB)	ANTENNA HEIGHT (m)	TABLE ANGLE (Degree)	RAW VALUE (dBuV)	CORRECTION FACTOR (dB/m)
1	#5605.60	56.8 PK	68.2	-11.4	3.82 V	357	52.30	4.50
2	*5825.00	122.1 PK			3.82 V	357	81.60	40.50
3	*5825.00	110.8 AV			3.82 V	357	70.30	40.50
4	#5944.00	58.0 PK	68.2	-10.2	3.82 V	357	52.80	5.20
5	11650.00	59.3 PK	74.0	-14.7	3.47 V	167	41.80	17.50
6	11650.00	46.4 AV	54.0	-7.6	3.47 V	167	28.90	17.50

Remarks:

1. Emission Level(dBuV/m) = Raw Value(dBuV) + Correction Factor(dB/m)
2. Correction Factor(dB/m) = Antenna Factor(dB/m) + Cable Factor(dB) – Pre-Amplifier Factor(dB)
3. The other emission levels were very low against the limit.
4. Margin value = Emission Level – Limit value
5. " * ": Fundamental frequency.
6. " # ": The radiated frequency is out of the restricted band.

802.11n (HT20)

CHANNEL	TX Channel 36	DETECTOR	Peak (PK)
FREQUENCY RANGE	1GHz ~ 40GHz	FUNCTION	Average (AV)

ANTENNA POLARITY & TEST DISTANCE: HORIZONTAL AT 3 M								
NO.	FREQ. (MHz)	EMISSION LEVEL (dBuV/m)	LIMIT (dBuV/m)	MARGIN (dB)	ANTENNA HEIGHT (m)	TABLE ANGLE (Degree)	RAW VALUE (dBuV)	CORRECTION FACTOR (dB/m)
1	5150.00	66.5 PK	74.0	-7.5	1.53 H	305	62.60	3.90
2	5150.00	52.4 AV	54.0	-1.6	1.53 H	305	48.50	3.90
3	*5180.00	121.1 PK			1.83 H	61	81.50	39.60
4	*5180.00	110.0 AV			1.83 H	61	70.40	39.60
5	#10360.00	58.2 PK	74.0	-15.8	2.63 H	211	42.40	15.80
6	#10360.00	44.8 AV	54.0	-9.2	2.63 H	211	29.00	15.80
ANTENNA POLARITY & TEST DISTANCE: VERTICAL AT 3 M								
NO.	FREQ. (MHz)	EMISSION LEVEL (dBuV/m)	LIMIT (dBuV/m)	MARGIN (dB)	ANTENNA HEIGHT (m)	TABLE ANGLE (Degree)	RAW VALUE (dBuV)	CORRECTION FACTOR (dB/m)
1	5150.00	65.3 PK	74.0	-8.7	3.96 V	358	61.40	3.90
2	5150.00	52.0 AV	54.0	-2.0	3.96 V	358	48.10	3.90
3	*5180.00	117.7 PK			3.90 V	303	78.10	39.60
4	*5180.00	106.4 AV			3.90 V	303	66.80	39.60
5	#10360.00	57.7 PK	74.0	-16.3	2.31 V	236	41.90	15.80
6	#10360.00	44.5 AV	54.0	-9.5	2.31 V	236	28.70	15.80

Remarks:

1. Emission Level(dBuV/m) = Raw Value(dBuV) + Correction Factor(dB/m)
2. Correction Factor(dB/m) = Antenna Factor(dB/m) + Cable Factor(dB) – Pre-Amplifier Factor(dB)
3. The other emission levels were very low against the limit.
4. Margin value = Emission Level – Limit value
5. " * ": Fundamental frequency.
6. " # ": The radiated frequency is out of the restricted band.

CHANNEL	TX Channel 40	DETECTOR FUNCTION	Peak (PK)
FREQUENCY RANGE	1GHz ~ 40GHz		Average (AV)

ANTENNA POLARITY & TEST DISTANCE: HORIZONTAL AT 3 M								
NO.	FREQ. (MHz)	EMISSION LEVEL (dBuV/m)	LIMIT (dBuV/m)	MARGIN (dB)	ANTENNA HEIGHT (m)	TABLE ANGLE (Degree)	RAW VALUE (dBuV)	CORRECTION FACTOR (dB/m)
1	5150.00	68.1 PK	74.0	-5.9	1.53 H	305	64.20	3.90
2	5150.00	52.2 AV	54.0	-1.8	1.53 H	305	48.30	3.90
3	*5200.00	125.6 PK			3.89 H	53	86.00	39.60
4	*5200.00	113.8 AV			3.89 H	53	74.20	39.60
5	#10400.00	58.4 PK	74.0	-15.6	2.31 H	186	42.50	15.90
6	#10400.00	45.0 AV	54.0	-9.0	2.31 H	186	29.10	15.90

ANTENNA POLARITY & TEST DISTANCE: VERTICAL AT 3 M								
NO.	FREQ. (MHz)	EMISSION LEVEL (dBuV/m)	LIMIT (dBuV/m)	MARGIN (dB)	ANTENNA HEIGHT (m)	TABLE ANGLE (Degree)	RAW VALUE (dBuV)	CORRECTION FACTOR (dB/m)
1	5150.00	66.6 PK	74.0	-7.4	4.00 V	18	62.70	3.90
2	5150.00	50.3 AV	54.0	-3.7	4.00 V	18	46.40	3.90
3	*5200.00	123.6 PK			3.95 V	350	84.00	39.60
4	*5200.00	112.3 AV			3.95 V	350	72.70	39.60
5	#10400.00	58.0 PK	74.0	-16.0	2.16 V	246	42.10	15.90
6	#10400.00	44.8 AV	54.0	-9.2	2.16 V	246	28.90	15.90

Remarks:

1. Emission Level(dBuV/m) = Raw Value(dBuV) + Correction Factor(dB/m)
2. Correction Factor(dB/m) = Antenna Factor(dB/m) + Cable Factor(dB) – Pre-Amplifier Factor(dB)
3. The other emission levels were very low against the limit.
4. Margin value = Emission Level – Limit value
5. " * ": Fundamental frequency.
6. " # ": The radiated frequency is out of the restricted band.

CHANNEL	TX Channel 48	DETECTOR	Peak (PK)
FREQUENCY RANGE	1GHz ~ 40GHz	FUNCTION	Average (AV)

ANTENNA POLARITY & TEST DISTANCE: HORIZONTAL AT 3 M

NO.	FREQ. (MHz)	EMISSION LEVEL (dBuV/m)	LIMIT (dBuV/m)	MARGIN (dB)	ANTENNA HEIGHT (m)	TABLE ANGLE (Degree)	RAW VALUE (dBuV)	CORRECTION FACTOR (dB/m)
1	*5240.00	125.4 PK			3.84 H	50	86.00	39.40
2	*5240.00	113.5 AV			3.84 H	50	74.10	39.40
3	5350.00	56.4 PK	74.0	-17.6	1.54 H	289	52.40	4.00
4	5350.00	43.2 AV	54.0	-10.8	1.54 H	289	39.20	4.00
5	#10480.00	59.4 PK	74.0	-14.6	2.54 H	189	42.70	16.70
6	#10480.00	45.5 AV	54.0	-8.5	2.54 H	189	28.80	16.70

ANTENNA POLARITY & TEST DISTANCE: VERTICAL AT 3 M

NO.	FREQ. (MHz)	EMISSION LEVEL (dBuV/m)	LIMIT (dBuV/m)	MARGIN (dB)	ANTENNA HEIGHT (m)	TABLE ANGLE (Degree)	RAW VALUE (dBuV)	CORRECTION FACTOR (dB/m)
1	*5240.00	120.3 PK			4.00 V	300	80.90	39.40
2	*5240.00	108.7 AV			4.00 V	300	69.30	39.40
3	5350.00	56.3 PK	74.0	-17.7	3.74 V	356	52.30	4.00
4	5350.00	43.0 AV	54.0	-11.0	3.74 V	356	39.00	4.00
5	#10480.00	59.8 PK	74.0	-14.2	2.36 V	287	43.10	16.70
6	#10480.00	45.4 AV	54.0	-8.6	2.36 V	287	28.70	16.70

Remarks:

1. Emission Level(dBuV/m) = Raw Value(dBuV) + Correction Factor(dB/m)
2. Correction Factor(dB/m) = Antenna Factor(dB/m) + Cable Factor(dB) – Pre-Amplifier Factor(dB)
3. The other emission levels were very low against the limit.
4. Margin value = Emission Level – Limit value
5. " * ": Fundamental frequency.
6. " # ": The radiated frequency is out of the restricted band.

CHANNEL	TX Channel 149	DETECTOR FUNCTION	Peak (PK)
FREQUENCY RANGE	1GHz ~ 40GHz		Average (AV)

ANTENNA POLARITY & TEST DISTANCE: HORIZONTAL AT 3 M

NO.	FREQ. (MHz)	EMISSION LEVEL (dBuV/m)	LIMIT (dBuV/m)	MARGIN (dB)	ANTENNA HEIGHT (m)	TABLE ANGLE (Degree)	RAW VALUE (dBuV)	CORRECTION FACTOR (dB/m)
1	#5611.54	55.9 PK	68.2	-12.3	1.76 H	51	51.6	4.3
2	*5745.00	124.0 PK			1.76 H	51	83.9	40.1
3	*5745.00	112.5 AV			1.76 H	51	72.4	40.1
4	#5989.10	57.9 PK	68.2	-10.3	1.76 H	51	52.8	5.1
5	11490.00	58.9 PK	74.0	-15.1	1.93 H	231	41.3	17.6
6	11490.00	45.2 AV	54.0	-8.8	1.93 H	231	27.6	17.6

ANTENNA POLARITY & TEST DISTANCE: VERTICAL AT 3 M

NO.	FREQ. (MHz)	EMISSION LEVEL (dBuV/m)	LIMIT (dBuV/m)	MARGIN (dB)	ANTENNA HEIGHT (m)	TABLE ANGLE (Degree)	RAW VALUE (dBuV)	CORRECTION FACTOR (dB/m)
1	#5600.64	55.1 PK	68.2	-13.1	1.03 V	48	50.8	4.3
2	*5745.00	119.7 PK			1.03 V	48	79.6	40.1
3	*5745.00	108.1 AV			1.03 V	48	68.0	40.1
4	#5987.18	57.4 PK	68.2	-10.8	1.03 V	48	52.3	5.1
5	11490.00	58.9 PK	74.0	-15.1	2.69 V	157	41.3	17.6
6	11490.00	45.1 AV	54.0	-8.9	2.69 V	157	27.5	17.6

Remarks:

1. Emission Level(dBuV/m) = Raw Value(dBuV) + Correction Factor(dB/m)
2. Correction Factor(dB/m) = Antenna Factor(dB/m) + Cable Factor(dB) – Pre-Amplifier Factor(dB)
3. The other emission levels were very low against the limit.
4. Margin value = Emission Level – Limit value
5. " * ": Fundamental frequency.
6. " # ": The radiated frequency is out of the restricted band.

CHANNEL	TX Channel 157	DETECTOR FUNCTION	Peak (PK)
FREQUENCY RANGE	1GHz ~ 40GHz		Average (AV)

ANTENNA POLARITY & TEST DISTANCE: HORIZONTAL AT 3 M								
NO.	FREQ. (MHz)	EMISSION LEVEL (dBuV/m)	LIMIT (dBuV/m)	MARGIN (dB)	ANTENNA HEIGHT (m)	TABLE ANGLE (Degree)	RAW VALUE (dBuV)	CORRECTION FACTOR (dB/m)
1	#5605.60	57.7 PK	68.2	-10.5	2.32 H	309	53.20	4.50
2	*5785.00	123.9 PK			2.32 H	309	83.60	40.30
3	*5785.00	112.4 AV			2.32 H	309	72.10	40.30
4	#5968.00	59.0 PK	68.2	-9.2	2.32 H	309	53.70	5.30
5	11570.00	60.8 PK	74.0	-13.2	2.07 H	193	42.90	17.90
6	11570.00	47.5 AV	54.0	-6.5	2.07 H	193	29.60	17.90

ANTENNA POLARITY & TEST DISTANCE: VERTICAL AT 3 M								
NO.	FREQ. (MHz)	EMISSION LEVEL (dBuV/m)	LIMIT (dBuV/m)	MARGIN (dB)	ANTENNA HEIGHT (m)	TABLE ANGLE (Degree)	RAW VALUE (dBuV)	CORRECTION FACTOR (dB/m)
1	#5603.20	56.8 PK	68.2	-11.4	3.24 V	22	52.30	4.50
2	*5785.00	121.8 PK			3.24 V	22	81.50	40.30
3	*5785.00	111.2 AV			3.24 V	22	70.90	40.30
4	#5971.20	58.8 PK	68.2	-9.4	3.24 V	22	53.50	5.30
5	11570.00	59.7 PK	74.0	-14.3	3.43 V	164	41.80	17.90
6	11570.00	47.0 AV	54.0	-7.0	3.43 V	164	29.10	17.90

Remarks:

1. Emission Level(dBuV/m) = Raw Value(dBuV) + Correction Factor(dB/m)
2. Correction Factor(dB/m) = Antenna Factor(dB/m) + Cable Factor(dB) – Pre-Amplifier Factor(dB)
3. The other emission levels were very low against the limit.
4. Margin value = Emission Level – Limit value
5. " * ": Fundamental frequency.
6. " # ": The radiated frequency is out of the restricted band.

CHANNEL	TX Channel 165	DETECTOR FUNCTION	Peak (PK)
FREQUENCY RANGE	1GHz ~ 40GHz		Average (AV)

ANTENNA POLARITY & TEST DISTANCE: HORIZONTAL AT 3 M

NO.	FREQ. (MHz)	EMISSION LEVEL (dBuV/m)	LIMIT (dBuV/m)	MARGIN (dB)	ANTENNA HEIGHT (m)	TABLE ANGLE (Degree)	RAW VALUE (dBuV)	CORRECTION FACTOR (dB/m)
1	#5633.60	57.8 PK	68.2	-10.4	1.92 H	306	53.30	4.50
2	*5825.00	124.3 PK			1.92 H	306	83.80	40.50
3	*5825.00	113.1 AV			1.92 H	306	72.60	40.50
4	#5945.60	58.8 PK	68.2	-9.4	1.92 H	306	53.60	5.20
5	11650.00	60.6 PK	74.0	-13.4	2.51 H	244	43.10	17.50
6	11650.00	47.4 AV	54.0	-6.6	2.51 H	244	29.90	17.50

ANTENNA POLARITY & TEST DISTANCE: VERTICAL AT 3 M

NO.	FREQ. (MHz)	EMISSION LEVEL (dBuV/m)	LIMIT (dBuV/m)	MARGIN (dB)	ANTENNA HEIGHT (m)	TABLE ANGLE (Degree)	RAW VALUE (dBuV)	CORRECTION FACTOR (dB/m)
1	#5610.40	57.6 PK	68.2	-10.6	3.26 V	37	53.10	4.50
2	*5825.00	121.7 PK			3.26 V	37	81.20	40.50
3	*5825.00	110.8 AV			3.26 V	37	70.30	40.50
4	#5975.20	58.6 PK	68.2	-9.6	3.26 V	37	53.30	5.30
5	11650.00	59.3 PK	74.0	-14.7	3.83 V	192	41.80	17.50
6	11650.00	46.5 AV	54.0	-7.5	3.83 V	192	29.00	17.50

Remarks:

1. Emission Level(dBuV/m) = Raw Value(dBuV) + Correction Factor(dB/m)
2. Correction Factor(dB/m) = Antenna Factor(dB/m) + Cable Factor(dB) – Pre-Amplifier Factor(dB)
3. The other emission levels were very low against the limit.
4. Margin value = Emission Level – Limit value
5. " * ": Fundamental frequency.
6. " # ": The radiated frequency is out of the restricted band.

802.11n (HT40)

CHANNEL	TX Channel 38	DETECTOR FUNCTION	Peak (PK)
FREQUENCY RANGE	1GHz ~ 40GHz		Average (AV)

ANTENNA POLARITY & TEST DISTANCE: HORIZONTAL AT 3 M

NO.	FREQ. (MHz)	EMISSION LEVEL (dBuV/m)	LIMIT (dBuV/m)	MARGIN (dB)	ANTENNA HEIGHT (m)	TABLE ANGLE (Degree)	RAW VALUE (dBuV)	CORRECTION FACTOR (dB/m)
1	5150.00	67.4 PK	74.0	-6.6	1.48 H	280	63.50	3.90
2	5150.00	52.6 AV	54.0	-1.4	1.48 H	280	48.70	3.90
3	*5190.00	115.9 PK			3.72 H	51	76.30	39.60
4	*5190.00	104.8 AV			3.72 H	51	65.20	39.60
5	#10380.00	59.4 PK	74.0	-14.6	2.46 H	187	43.50	15.90
6	#10380.00	45.3 AV	54.0	-8.7	2.46 H	187	29.40	15.90

ANTENNA POLARITY & TEST DISTANCE: VERTICAL AT 3 M

NO.	FREQ. (MHz)	EMISSION LEVEL (dBuV/m)	LIMIT (dBuV/m)	MARGIN (dB)	ANTENNA HEIGHT (m)	TABLE ANGLE (Degree)	RAW VALUE (dBuV)	CORRECTION FACTOR (dB/m)
1	5150.00	63.9 PK	74.0	-10.1	4.00 V	20	60.00	3.90
2	5150.00	49.9 AV	54.0	-4.1	4.00 V	20	46.00	3.90
3	*5190.00	113.7 PK			3.57 V	343	74.10	39.60
4	*5190.00	103.3 AV			3.57 V	343	63.70	39.60
5	#10380.00	58.3 PK	74.0	-15.7	2.55 V	189	42.40	15.90
6	#10380.00	44.7 AV	54.0	-9.3	2.55 V	189	28.80	15.90

Remarks:

1. Emission Level(dBuV/m) = Raw Value(dBuV) + Correction Factor(dB/m)
2. Correction Factor(dB/m) = Antenna Factor(dB/m) + Cable Factor(dB) – Pre-Amplifier Factor(dB)
3. The other emission levels were very low against the limit.
4. Margin value = Emission Level – Limit value
5. " * ": Fundamental frequency.
6. " # ": The radiated frequency is out of the restricted band.

CHANNEL	TX Channel 46	DETECTOR FUNCTION	Peak (PK)
FREQUENCY RANGE	1GHz ~ 40GHz		Average (AV)

ANTENNA POLARITY & TEST DISTANCE: HORIZONTAL AT 3 M								
NO.	FREQ. (MHz)	EMISSION LEVEL (dBuV/m)	LIMIT (dBuV/m)	MARGIN (dB)	ANTENNA HEIGHT (m)	TABLE ANGLE (Degree)	RAW VALUE (dBuV)	CORRECTION FACTOR (dB/m)
1	5150.00	65.0 PK	74.0	-9.0	1.88 H	278	61.1	3.9
2	5150.00	50.6 AV	54.0	-3.4	1.88 H	278	46.7	3.9
3	*5230.00	119.2 PK			2.12 H	39	79.9	39.3
4	*5230.00	108.9 AV			2.12 H	39	69.6	39.3
5	5350.00	60.3 PK	74.0	-13.7	1.70 H	290	56.4	3.9
6	5350.00	45.9 AV	54.0	-8.1	1.70 H	290	42.0	3.9
7	#10460.00	59.2 PK	68.2	-9.0	1.50 H	245	42.6	16.6
ANTENNA POLARITY & TEST DISTANCE: VERTICAL AT 3 M								
NO.	FREQ. (MHz)	EMISSION LEVEL (dBuV/m)	LIMIT (dBuV/m)	MARGIN (dB)	ANTENNA HEIGHT (m)	TABLE ANGLE (Degree)	RAW VALUE (dBuV)	CORRECTION FACTOR (dB/m)
1	5150.00	63.0 PK	74.0	-11.0	3.90 V	12	59.1	3.9
2	5150.00	49.5 AV	54.0	-4.5	3.90 V	12	45.6	3.9
3	*5230.00	113.6 PK			1.56 V	49	74.3	39.3
4	*5230.00	103.1 AV			1.56 V	49	63.8	39.3
5	5350.00	56.6 PK	74.0	-17.4	1.94 V	236	52.7	3.9
6	5350.00	43.9 AV	54.0	-10.1	1.94 V	236	40.0	3.9
7	#10460.00	58.3 PK	68.2	-9.9	1.32 V	164	41.7	16.6

Remarks:

1. Emission Level(dBuV/m) = Raw Value(dBuV) + Correction Factor(dB/m)
2. Correction Factor(dB/m) = Antenna Factor(dB/m) + Cable Factor(dB) – Pre-Amplifier Factor(dB)
3. The other emission levels were very low against the limit.
4. Margin value = Emission Level – Limit value
5. " * ": Fundamental frequency.
6. " # ": The radiated frequency is out of the restricted band.

CHANNEL	TX Channel 151	DETECTOR FUNCTION	Peak (PK)
FREQUENCY RANGE	1GHz ~ 40GHz		Average (AV)

ANTENNA POLARITY & TEST DISTANCE: HORIZONTAL AT 3 M								
NO.	FREQ. (MHz)	EMISSION LEVEL (dBuV/m)	LIMIT (dBuV/m)	MARGIN (dB)	ANTENNA HEIGHT (m)	TABLE ANGLE (Degree)	RAW VALUE (dBuV)	CORRECTION FACTOR (dB/m)
1	#5642.40	62.1 PK	68.2	-6.1	3.31 H	284	57.50	4.60
2	#5650.00	66.5 PK	68.2	-1.7	3.41 H	286	61.90	4.60
3	*5755.00	120.5 PK			3.31 H	284	80.40	40.10
4	*5755.00	109.5 AV			3.31 H	284	69.40	40.10
5	#5959.20	58.2 PK	68.2	-10.0	3.31 H	284	53.00	5.20
6	11510.00	59.6 PK	74.0	-14.4	2.83 H	256	42.00	17.60
7	11510.00	46.6 AV	54.0	-7.4	2.83 H	256	29.00	17.60
ANTENNA POLARITY & TEST DISTANCE: VERTICAL AT 3 M								
NO.	FREQ. (MHz)	EMISSION LEVEL (dBuV/m)	LIMIT (dBuV/m)	MARGIN (dB)	ANTENNA HEIGHT (m)	TABLE ANGLE (Degree)	RAW VALUE (dBuV)	CORRECTION FACTOR (dB/m)
1	#5649.60	58.0 PK	68.2	-10.2	3.27 V	16	53.40	4.60
2	#5650.00	62.2 PK	68.2	-6.0	3.84 V	356	57.60	4.60
3	*5755.00	119.1 PK			3.27 V	16	79.00	40.10
4	*5755.00	108.5 AV			3.27 V	16	68.40	40.10
5	#5955.20	58.1 PK	68.2	-10.1	3.27 V	16	52.90	5.20
6	11510.00	58.9 PK	74.0	-15.1	3.10 V	148	41.30	17.60
7	11510.00	46.4 AV	54.0	-7.6	3.10 V	148	28.80	17.60

Remarks:

1. Emission Level(dBuV/m) = Raw Value(dBuV) + Correction Factor(dB/m)
2. Correction Factor(dB/m) = Antenna Factor(dB/m) + Cable Factor(dB) – Pre-Amplifier Factor(dB)
3. The other emission levels were very low against the limit.
4. Margin value = Emission Level – Limit value
5. " * ": Fundamental frequency.
6. " # ": The radiated frequency is out of the restricted band.

CHANNEL	TX Channel 159	DETECTOR FUNCTION	Peak (PK)
FREQUENCY RANGE	1GHz ~ 40GHz		Average (AV)

ANTENNA POLARITY & TEST DISTANCE: HORIZONTAL AT 3 M								
NO.	FREQ. (MHz)	EMISSION LEVEL (dBuV/m)	LIMIT (dBuV/m)	MARGIN (dB)	ANTENNA HEIGHT (m)	TABLE ANGLE (Degree)	RAW VALUE (dBuV)	CORRECTION FACTOR (dB/m)
1	#5611.20	58.3 PK	68.2	-9.9	3.47 H	282	53.80	4.50
2	*5795.00	120.3 PK			3.47 H	282	80.00	40.30
3	*5795.00	109.9 AV			3.47 H	282	69.60	40.30
4	#5930.40	59.1 PK	68.2	-9.1	3.47 H	282	53.90	5.20
5	11590.00	61.0 PK	74.0	-13.0	2.31 H	269	43.10	17.90
6	11590.00	47.9 AV	54.0	-6.1	2.31 H	269	30.00	17.90
ANTENNA POLARITY & TEST DISTANCE: VERTICAL AT 3 M								
NO.	FREQ. (MHz)	EMISSION LEVEL (dBuV/m)	LIMIT (dBuV/m)	MARGIN (dB)	ANTENNA HEIGHT (m)	TABLE ANGLE (Degree)	RAW VALUE (dBuV)	CORRECTION FACTOR (dB/m)
1	#5645.60	57.3 PK	68.2	-10.9	3.69 V	23	52.70	4.60
2	*5795.00	119.7 PK			3.69 V	23	79.40	40.30
3	*5795.00	108.5 AV			3.69 V	23	68.20	40.30
4	#5957.60	58.0 PK	68.2	-10.2	3.69 V	23	52.80	5.20
5	11590.00	60.6 PK	74.0	-13.4	2.98 V	163	42.70	17.90
6	11590.00	47.2 AV	54.0	-6.8	2.98 V	163	29.30	17.90

Remarks:

1. Emission Level(dBuV/m) = Raw Value(dBuV) + Correction Factor(dB/m)
2. Correction Factor(dB/m) = Antenna Factor(dB/m) + Cable Factor(dB) – Pre-Amplifier Factor(dB)
3. The other emission levels were very low against the limit.
4. Margin value = Emission Level – Limit value
5. " * ": Fundamental frequency.
6. " # ": The radiated frequency is out of the restricted band.

802.11ac (VHT80)

CHANNEL	TX Channel 42	DETECTOR FUNCTION	Peak (PK)
FREQUENCY RANGE	1GHz ~ 40GHz		Average (AV)

ANTENNA POLARITY & TEST DISTANCE: HORIZONTAL AT 3 M								
NO.	FREQ. (MHz)	EMISSION LEVEL (dBuV/m)	LIMIT (dBuV/m)	MARGIN (dB)	ANTENNA HEIGHT (m)	TABLE ANGLE (Degree)	RAW VALUE (dBuV)	CORRECTION FACTOR (dB/m)
1	5150.00	67.0 PK	74.0	-7.0	1.52 H	279	63.10	3.90
2	5150.00	52.9 AV	54.0	-1.1	1.52 H	279	49.00	3.90
3	*5210.00	112.0 PK			3.89 H	52	72.50	39.50
4	*5210.00	101.2 AV			3.89 H	52	61.70	39.50
5	5350.00	59.6 PK	74.0	-14.4	1.44 H	296	55.60	4.00
6	5350.00	45.6 AV	54.0	-8.4	1.44 H	296	41.60	4.00
7	#10420.00	58.3 PK	74.0	-15.7	1.96 H	188	42.30	16.00
8	#10420.00	44.9 AV	54.0	-9.1	1.96 H	188	28.90	16.00
ANTENNA POLARITY & TEST DISTANCE: VERTICAL AT 3 M								
NO.	FREQ. (MHz)	EMISSION LEVEL (dBuV/m)	LIMIT (dBuV/m)	MARGIN (dB)	ANTENNA HEIGHT (m)	TABLE ANGLE (Degree)	RAW VALUE (dBuV)	CORRECTION FACTOR (dB/m)
1	5150.00	63.7 PK	74.0	-10.3	3.92 V	16	59.80	3.90
2	5150.00	50.6 AV	54.0	-3.4	3.92 V	16	46.70	3.90
3	*5210.00	110.2 PK			3.55 V	346	70.70	39.50
4	*5210.00	99.7 AV			3.55 V	346	60.20	39.50
5	5350.00	58.9 PK	74.0	-15.1	3.76 V	355	54.90	4.00
6	5350.00	45.1 AV	54.0	-8.9	3.76 V	355	41.10	4.00
7	#10420.00	58.5 PK	74.0	-15.5	2.88 V	312	42.50	16.00
8	#10420.00	45.3 AV	54.0	-8.7	2.88 V	312	29.30	16.00

Remarks:

1. Emission Level(dBuV/m) = Raw Value(dBuV) + Correction Factor(dB/m)
2. Correction Factor(dB/m) = Antenna Factor(dB/m) + Cable Factor(dB) – Pre-Amplifier Factor(dB)
3. The other emission levels were very low against the limit.
4. Margin value = Emission Level – Limit value
5. " * ": Fundamental frequency.
6. " # ": The radiated frequency is out of the restricted band.

CHANNEL	TX Channel 155	DETECTOR FUNCTION	Peak (PK)
FREQUENCY RANGE	1GHz ~ 40GHz		Average (AV)

ANTENNA POLARITY & TEST DISTANCE: HORIZONTAL AT 3 M								
NO.	FREQ. (MHz)	EMISSION LEVEL (dBuV/m)	LIMIT (dBuV/m)	MARGIN (dB)	ANTENNA HEIGHT (m)	TABLE ANGLE (Degree)	RAW VALUE (dBuV)	CORRECTION FACTOR (dB/m)
1	#5643.20	62.0 PK	68.2	-6.2	3.30 H	285	57.40	4.60
2	#5650.00	67.1 PK	68.2	-1.1	3.40 H	283	62.50	4.60
3	*5775.00	112.2 PK			3.30 H	285	72.00	40.20
4	*5775.00	101.9 AV			3.30 H	285	61.70	40.20
5	#5925.00	65.4 PK	68.2	-2.8	3.46 H	312	60.20	5.20
6	#5927.20	61.2 PK	68.2	-7.0	3.30 H	285	56.00	5.20
7	11550.00	60.3 PK	74.0	-13.7	2.86 H	234	42.50	17.80
8	11550.00	47.1 AV	54.0	-6.9	2.86 H	234	29.30	17.80
ANTENNA POLARITY & TEST DISTANCE: VERTICAL AT 3 M								
NO.	FREQ. (MHz)	EMISSION LEVEL (dBuV/m)	LIMIT (dBuV/m)	MARGIN (dB)	ANTENNA HEIGHT (m)	TABLE ANGLE (Degree)	RAW VALUE (dBuV)	CORRECTION FACTOR (dB/m)
1	#5633.60	58.6 PK	68.2	-9.6	3.39 V	26	54.10	4.50
2	#5650.00	63.0 PK	68.2	-5.2	3.68 V	349	58.40	4.60
3	*5775.00	110.6 PK			3.39 V	26	70.40	40.20
4	*5775.00	100.3 AV			3.39 V	26	60.10	40.20
5	#5925.00	61.5 PK	68.2	-6.7	2.94 V	17	56.30	5.20
6	#5927.20	58.5 PK	68.2	-9.7	3.39 V	26	53.30	5.20
7	11550.00	59.2 PK	74.0	-14.8	3.62 V	183	41.40	17.80
8	11550.00	46.6 AV	54.0	-7.4	3.62 V	183	28.80	17.80

Remarks:

1. Emission Level(dBuV/m) = Raw Value(dBuV) + Correction Factor(dB/m)
2. Correction Factor(dB/m) = Antenna Factor(dB/m) + Cable Factor(dB) – Pre-Amplifier Factor(dB)
3. The other emission levels were very low against the limit.
4. Margin value = Emission Level – Limit value
5. " * ": Fundamental frequency.
6. " # ": The radiated frequency is out of the restricted band.

802.11ac (VHT80+VHT80)

CHANNEL	TX Channel 42+155	DETECTOR FUNCTION	Peak (PK) Average (AV)
FREQUENCY RANGE	1GHz ~ 40GHz		

ANTENNA POLARITY & TEST DISTANCE: HORIZONTAL AT 3 M								
NO.	FREQ. (MHz)	EMISSION LEVEL (dBuV/m)	LIMIT (dBuV/m)	MARGIN (dB)	ANTENNA HEIGHT (m)	TABLE ANGLE (Degree)	RAW VALUE (dBuV)	CORRECTION FACTOR (dB/m)
1	5150.00	66.1 PK	74.0	-7.9	3.78 H	283	62.20	3.90
2	5150.00	50.3 AV	54.0	-3.7	3.78 H	283	46.40	3.90
3	*5210.00	109.2 PK			1.61 H	297	69.70	39.50
4	*5210.00	99.1 AV			1.61 H	297	59.60	39.50
5	5350.00	57.2 PK	74.0	-16.8	2.85 H	354	53.20	4.00
6	5350.00	44.3 AV	54.0	-9.7	2.85 H	354	40.30	4.00
7	#5645.60	57.3 PK	68.2	-10.9	2.02 H	38	52.70	4.60
8	#5650.00	60.1 PK	68.2	-8.1	2.22 H	39	55.50	4.60
9	*5775.00	109.1 PK			2.02 H	38	68.90	40.20
10	*5775.00	98.1 AV			2.02 H	38	57.90	40.20
11	#5925.00	58.2 PK	68.2	-10.0	2.96 H	267	53.00	5.20
12	#5987.20	57.5 PK	68.2	-10.7	2.02 H	38	52.20	5.30
13	#10420.00	58.6 PK	74.0	-15.4	1.83 H	262	42.60	16.00
14	#10420.00	45.3 AV	54.0	-8.7	1.83 H	262	29.30	16.00
15	11550.00	60.8 PK	74.0	-13.2	2.31 H	189	43.00	17.80
16	11550.00	47.5 AV	54.0	-6.5	2.31 H	189	29.70	17.80

ANTENNA POLARITY & TEST DISTANCE: VERTICAL AT 3 M								
NO.	FREQ. (MHz)	EMISSION LEVEL (dBuV/m)	LIMIT (dBuV/m)	MARGIN (dB)	ANTENNA HEIGHT (m)	TABLE ANGLE (Degree)	RAW VALUE (dBuV)	CORRECTION FACTOR (dB/m)
1	5150.00	60.2 PK	74.0	-13.8	1.64 V	354	56.30	3.90
2	5150.00	47.9 AV	54.0	-6.1	1.64 V	354	44.00	3.90
3	*5210.00	102.8 PK			1.49 V	54	63.30	39.50
4	*5210.00	92.7 AV			1.49 V	54	53.20	39.50
5	5350.00	57.3 PK	74.0	-16.7	2.32 V	112	53.30	4.00
6	5350.00	43.9 AV	54.0	-10.1	2.32 V	112	39.90	4.00
7	#5647.20	56.8 PK	68.2	-11.4	1.38 V	54	52.20	4.60
8	#5650.00	57.2 PK	74.0	-16.8	2.39 V	117	52.60	4.60
9	*5775.00	104.0 PK			1.38 V	54	63.80	40.20
10	*5775.00	93.8 AV			1.38 V	54	53.60	40.20
11	#5925.00	57.8 PK	74.0	-16.2	1.93 V	307	52.60	5.20
12	#5934.40	56.4 PK	68.2	-11.8	1.38 V	54	51.20	5.20
13	#10420.00	59.7 PK	74.0	-14.3	2.96 V	351	43.70	16.00
14	#10420.00	45.5 AV	54.0	-8.5	2.96 V	351	29.50	16.00
15	11550.00	60.4 PK	74.0	-13.6	2.63 V	284	42.60	17.80
16	11550.00	47.1 AV	54.0	-6.9	2.63 V	284	29.30	17.80

REMARKS:

1. Emission Level(dBuV/m) = Raw Value(dBuV) + Correction Factor(dB/m)
2. Correction Factor(dB/m) = Antenna Factor(dB/m) + Cable Factor(dB)
– Pre-Amplifier Factor(dB)
3. The other emission levels were very low against the limit.
4. Margin value = Emission Level – Limit value
5. " * ": Fundamental frequency.
6. " # ": The radiated frequency is out of the restricted band.

Below 1GHz Worst-Case Data: 802.11a

CHANNEL	TX Channel 157	DETECTOR FUNCTION	Quasi-Peak (QP)
FREQUENCY RANGE	9kHz ~ 1GHz	TEST MODE	A

ANTENNA POLARITY & TEST DISTANCE: HORIZONTAL AT 3 M								
NO.	FREQ. (MHz)	EMISSION LEVEL (dBuV/m)	LIMIT (dBuV/m)	MARGIN (dB)	ANTENNA HEIGHT (m)	TABLE ANGLE (Degree)	RAW VALUE (dBuV)	CORRECTION FACTOR (dB/m)
1	125.17	39.5 QP	43.5	-4.0	1.51 H	238	50.5	-11.0
2	255.44	44.7 QP	46.0	-1.3	1.01 H	98	53.7	-9.0
3	263.21	40.5 QP	46.0	-5.5	1.01 H	114	49.1	-8.6
4	374.04	39.4 QP	46.0	-6.6	1.01 H	112	45.3	-5.9
5	486.72	41.1 QP	46.0	-4.9	1.50 H	15	45.0	-3.9
6	624.85	40.5 QP	46.0	-5.5	1.01 H	294	41.2	-0.7

Remarks:

1. Emission Level(dBuV/m) = Raw Value(dBuV) + Correction Factor(dB/m)
2. Correction Factor(dB/m) = Antenna Factor(dB/m) + Cable Factor(dB) – Pre-Amplifier Factor(dB)
3. The other emission levels were very low against the limit of frequency range 30MHz~1000MHz.
4. Margin value = Emission Level – Limit value
5. The emission levels were very low against the limit of frequency range 9kHz~30MHz: the amplitude of spurious emissions attenuated more than 20dB below the permissible value to be report.

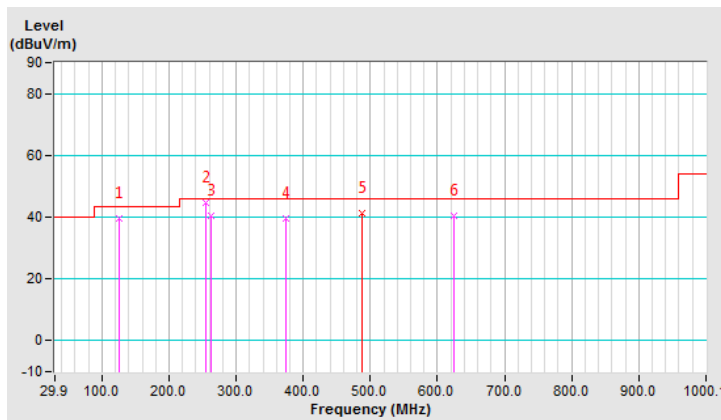

CHANNEL	TX Channel 157	DETECTOR FUNCTION	Quasi-Peak (QP)
FREQUENCY RANGE	9kHz ~ 1GHz	TEST MODE	A

ANTENNA POLARITY & TEST DISTANCE: VERTICAL AT 3 M								
NO.	FREQ. (MHz)	EMISSION LEVEL (dBuV/m)	LIMIT (dBuV/m)	MARGIN (dB)	ANTENNA HEIGHT (m)	TABLE ANGLE (Degree)	RAW VALUE (dBuV)	CORRECTION FACTOR (dB/m)
1	61.01	35.6 QP	40.0	-4.4	1.00 V	272	46.1	-10.5
2	125.17	35.0 QP	43.5	-8.5	1.00 V	244	46.0	-11.0
3	255.44	35.0 QP	46.0	-11.0	1.99 V	219	44.0	-9.0
4	374.04	40.2 QP	46.0	-5.8	1.50 V	22	46.1	-5.9
5	488.75	44.2 QP	46.0	-1.8	1.00 V	334	48.1	-3.9
6	624.85	40.4 QP	46.0	-5.6	1.00 V	356	41.1	-0.7

Remarks:

1. Emission Level(dBuV/m) = Raw Value(dBuV) + Correction Factor(dB/m)
2. Correction Factor(dB/m) = Antenna Factor(dB/m) + Cable Factor(dB) – Pre-Amplifier Factor(dB)
3. The other emission levels were very low against the limit of frequency range 30MHz~1000MHz.
4. Margin value = Emission Level – Limit value
5. The emission levels were very low against the limit of frequency range 9kHz~30MHz: the amplitude of spurious emissions attenuated more than 20dB below the permissible value to be report.

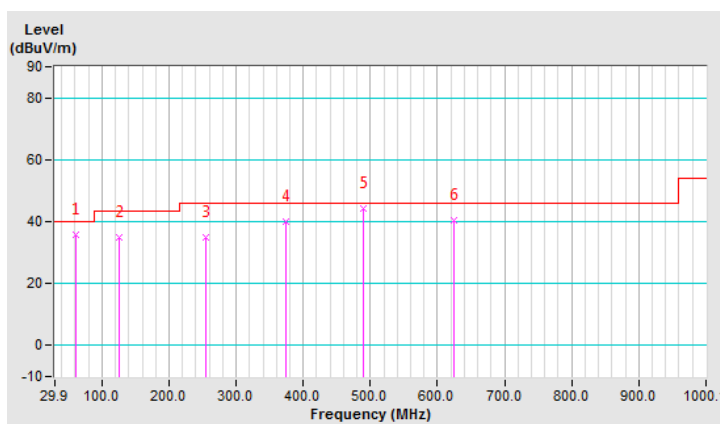

CHANNEL	TX Channel 157	DETECTOR FUNCTION	Quasi-Peak (QP)
FREQUENCY RANGE	9kHz ~ 1GHz	TEST MODE	B

ANTENNA POLARITY & TEST DISTANCE: HORIZONTAL AT 3 M								
NO.	FREQ. (MHz)	EMISSION LEVEL (dBuV/m)	LIMIT (dBuV/m)	MARGIN (dB)	ANTENNA HEIGHT (m)	TABLE ANGLE (Degree)	RAW VALUE (dBuV)	CORRECTION FACTOR (dB/m)
1	125.17	38.5 QP	43.5	-5.0	2.00 H	256	49.5	-11.0
2	255.44	42.0 QP	46.0	-4.0	1.01 H	320	51.0	-9.0
3	374.04	38.3 QP	46.0	-7.7	1.01 H	216	44.2	-5.9
4	486.73	42.7 QP	46.0	-3.3	1.50 H	3	46.6	-3.9
5	624.85	40.8 QP	46.0	-5.2	1.01 H	127	41.5	-0.7
6	751.23	39.9 QP	46.0	-6.1	1.01 H	79	38.1	1.8

Remarks:

1. Emission Level(dBuV/m) = Raw Value(dBuV) + Correction Factor(dB/m)
2. Correction Factor(dB/m) = Antenna Factor(dB/m) + Cable Factor(dB) – Pre-Amplifier Factor(dB)
3. The other emission levels were very low against the limit of frequency range 30MHz~1000MHz.
4. Margin value = Emission Level – Limit value
5. The emission levels were very low against the limit of frequency range 9kHz~30MHz: the amplitude of spurious emissions attenuated more than 20dB below the permissible value to be report.

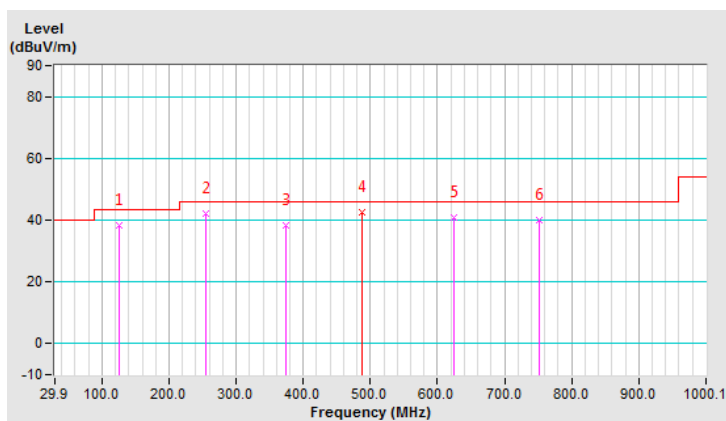

CHANNEL	TX Channel 157	DETECTOR FUNCTION	Quasi-Peak (QP)
FREQUENCY RANGE	9kHz ~ 1GHz	TEST MODE	B

ANTENNA POLARITY & TEST DISTANCE: VERTICAL AT 3 M								
NO.	FREQ. (MHz)	EMISSION LEVEL (dBuV/m)	LIMIT (dBuV/m)	MARGIN (dB)	ANTENNA HEIGHT (m)	TABLE ANGLE (Degree)	RAW VALUE (dBuV)	CORRECTION FACTOR (dB/m)
1	45.45	37.1 QP	40.0	-2.9	1.01 V	16	46.9	-9.8
2	125.17	41.9 QP	43.5	-1.6	1.01 V	16	52.9	-11.0
3	374.04	40.0 QP	46.0	-6.0	1.51 V	14	45.9	-5.9
4	490.70	42.8 QP	46.0	-3.2	1.01 V	314	46.6	-3.8
5	494.58	42.5 QP	46.0	-3.5	1.01 V	308	46.3	-3.8
6	624.85	40.9 QP	46.0	-5.1	1.01 V	349	41.6	-0.7

Remarks:

1. Emission Level(dBuV/m) = Raw Value(dBuV) + Correction Factor(dB/m)
2. Correction Factor(dB/m) = Antenna Factor(dB/m) + Cable Factor(dB) – Pre-Amplifier Factor(dB)
3. The other emission levels were very low against the limit of frequency range 30MHz~1000MHz.
4. Margin value = Emission Level – Limit value
5. The emission levels were very low against the limit of frequency range 9kHz~30MHz: the amplitude of spurious emissions attenuated more than 20dB below the permissible value to be report.

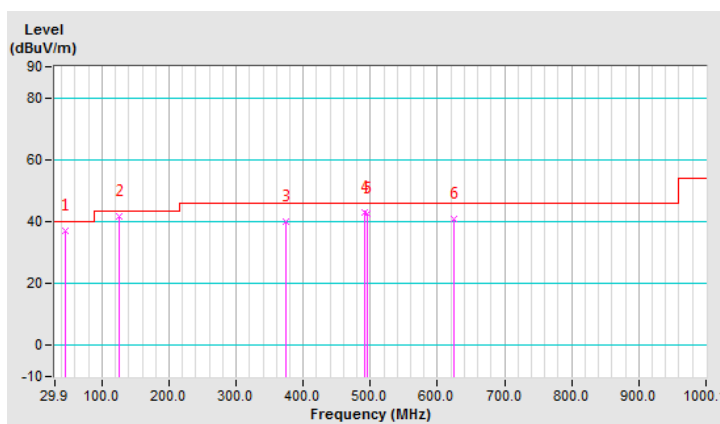

CHANNEL	TX Channel 157	DETECTOR FUNCTION	Quasi-Peak (QP)
FREQUENCY RANGE	9kHz ~ 1GHz	TEST MODE	C

ANTENNA POLARITY & TEST DISTANCE: HORIZONTAL AT 3 M								
NO.	FREQ. (MHz)	EMISSION LEVEL (dBUV/m)	LIMIT (dBUV/m)	MARGIN (dB)	ANTENNA HEIGHT (m)	TABLE ANGLE (Degree)	RAW VALUE (dBUV)	CORRECTION FACTOR (dB/m)
1	92.12	35.4 QP	43.5	-8.1	2.00 H	271	49.8	-14.4
2	181.55	36.8 QP	43.5	-6.7	1.51 H	259	47.2	-10.4
3	247.66	42.9 QP	46.0	-3.1	1.00 H	289	52.1	-9.2
4	374.04	39.4 QP	46.0	-6.6	2.00 H	250	45.3	-5.9
5	480.97	44.8 QP	46.0	-1.2	1.51 H	359	48.8	-4.0
6	624.85	38.8 QP	46.0	-7.2	1.00 H	139	39.5	-0.7

Remarks:

1. Emission Level(dBuV/m) = Raw Value(dBuV) + Correction Factor(dB/m)
2. Correction Factor(dB/m) = Antenna Factor(dB/m) + Cable Factor(dB) – Pre-Amplifier Factor(dB)
3. The other emission levels were very low against the limit of frequency range 30MHz~1000MHz.
4. Margin value = Emission Level – Limit value
5. The emission levels were very low against the limit of frequency range 9kHz~30MHz: the amplitude of spurious emissions attenuated more than 20dB below the permissible value to be report.

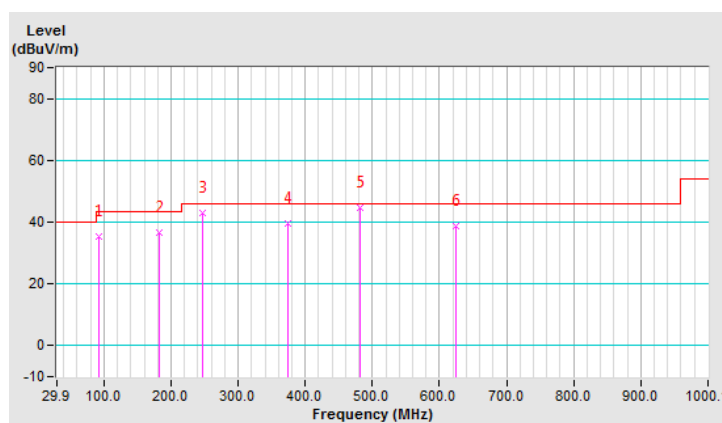

CHANNEL	TX Channel 157	DETECTOR FUNCTION	Quasi-Peak (QP)
FREQUENCY RANGE	9kHz ~ 1GHz	TEST MODE	C

ANTENNA POLARITY & TEST DISTANCE: VERTICAL AT 3 M

NO.	FREQ. (MHz)	EMISSION LEVEL (dBuV/m)	LIMIT (dBuV/m)	MARGIN (dB)	ANTENNA HEIGHT (m)	TABLE ANGLE (Degree)	RAW VALUE (dBuV)	CORRECTION FACTOR (dB/m)
1	62.95	38.3 QP	40.0	-1.7	1.00 V	47	48.6	-10.3
2	72.67	36.6 QP	40.0	-3.4	1.49 V	36	49.1	-12.5
3	183.50	37.5 QP	43.5	-6.0	1.00 V	133	48.1	-10.6
4	249.60	37.8 QP	46.0	-8.2	1.99 V	312	46.9	-9.1
5	492.64	39.3 QP	46.0	-6.7	1.00 V	8	43.1	-3.8
6	624.85	40.2 QP	46.0	-5.8	1.00 V	139	40.9	-0.7

Remarks:

1. Emission Level(dBuV/m) = Raw Value(dBuV) + Correction Factor(dB/m)
2. Correction Factor(dB/m) = Antenna Factor(dB/m) + Cable Factor(dB) – Pre-Amplifier Factor(dB)
3. The other emission levels were very low against the limit of frequency range 30MHz~1000MHz.
4. Margin value = Emission Level – Limit value
5. The emission levels were very low against the limit of frequency range 9kHz~30MHz: the amplitude of spurious emissions attenuated more than 20dB below the permissible value to be report.

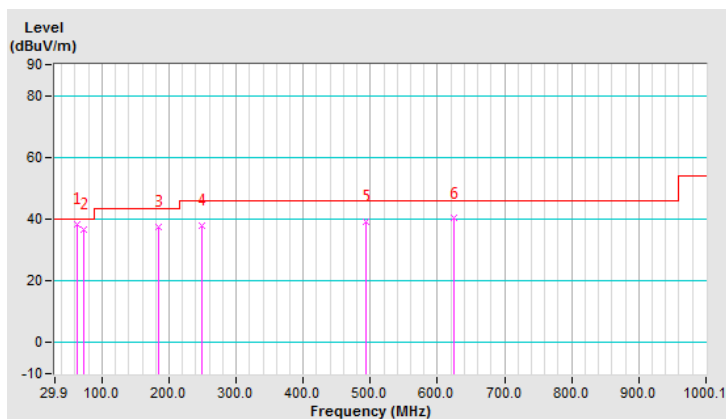

4.2 Conducted Emission Measurement

4.2.1 Limits of Conducted Emission Measurement

Frequency (MHz)	Conducted Limit (dBuV)	
	Quasi-peak	Average
0.15 - 0.5	66 - 56	56 - 46
0.50 - 5.0	56	46
5.0 - 30.0	60	50

Note: 1. The lower limit shall apply at the transition frequencies.

2. The limit decreases in line with the logarithm of the frequency in the range of 0.15 to 0.50MHz.

4.2.2 Test Instruments

Tested date: Mar. 08 ~ Mar. 19, 2019

Description & Manufacturer	Model No.	Serial No.	Date Of Calibration	Due Date Of Calibration
Test Receiver ROHDE & SCHWARZ	ESCS 30	100288	Jan. 03, 2019	Jan. 02, 2020
RF signal cable (with 10dB PAD) Woken	5D-FB	Cable-cond1-01	Sep. 05, 2018	Sep. 04, 2019
LISN ROHDE & SCHWARZ (EUT)	ENV216	101826	Feb. 21, 2019	Feb. 20, 2020
LISN ROHDE & SCHWARZ (Peripheral)	ESH3-Z5	100311	Aug. 19, 2018	Aug. 18, 2019
Software ADT	BV ADT_Cond_ V7.3.7.4	NA	NA	NA

Note: 1. The calibration interval of the above test instruments is 12 months and the calibrations are traceable to NML/ROC and NIST/USA.

2. The test was performed in HwaYa Shielded Room 1.

3. The VCCI Site Registration No. is C-2040.

4.2.3 Test Procedures

- The EUT was placed 0.4 meters from the conducting wall of the shielded room with EUT being connected to the power mains through a line impedance stabilization network (LISN). Other support units were connected to the power mains through another LISN. The two LISNs provide 50 ohm/ 50uH of coupling impedance for the measuring instrument.
- Both lines of the power mains connected to the EUT were checked for maximum conducted interference.
- The frequency range from 150kHz to 30MHz was searched. Emission levels under (Limit - 20dB) was not recorded.

NOTE: The resolution bandwidth and video bandwidth of test receiver is 9kHz for quasi-peak detection (QP) and average detection (AV) at frequency 0.15MHz-30MHz.

4.2.4 Deviation from Test Standard

No deviation.

4.2.5 Test Setup

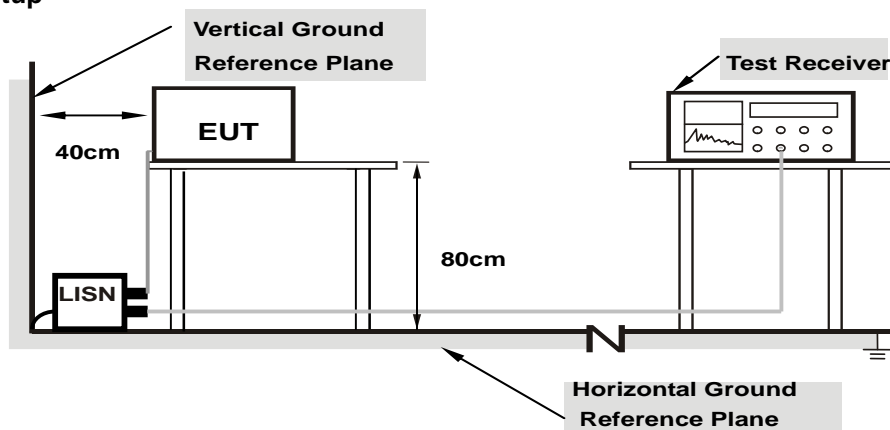

Note: 1.Support units were connected to second LISN.

For the actual test configuration, please refer to the attached file (Test Setup Photo).

4.2.6 EUT Operating Conditions

Same as 4.1.6.

4.2.7 Test Results

Phase	Line (L)	Detector Function	Quasi-Peak (QP) / Average (AV)
Test Mode	A		

No	Freq. [MHz]	Corr. Factor (dB)	Reading Value [dB (uV)]		Emission Level [dB (uV)]		Limit [dB (uV)]		Margin (dB)	
			Q.P.	AV.	Q.P.	AV.	Q.P.	AV.	Q.P.	AV.
			1	0.15000	9.69	43.67	30.86	53.36	40.55	66.00
2	0.15800	9.69	41.66	25.88	51.35	35.57	65.57	55.57	-14.22	-20.00
3	0.21805	9.68	33.13	20.22	42.81	29.90	62.89	52.89	-20.08	-22.99
4	0.31400	9.68	36.78	29.84	46.46	39.52	59.86	49.86	-13.40	-10.34
5	0.53404	9.68	21.82	15.40	31.50	25.08	56.00	46.00	-24.50	-20.92
6	10.04200	9.87	14.23	9.20	24.10	19.07	60.00	50.00	-35.90	-30.93

REMARKS:

1. Q.P. and AV. are abbreviations of quasi-peak and average individually.
2. The emission levels of other frequencies were very low against the limit.
3. Margin value = Emission level - Limit value
4. Correction factor = Insertion loss + Cable loss
5. Emission Level = Correction Factor + Reading Value.

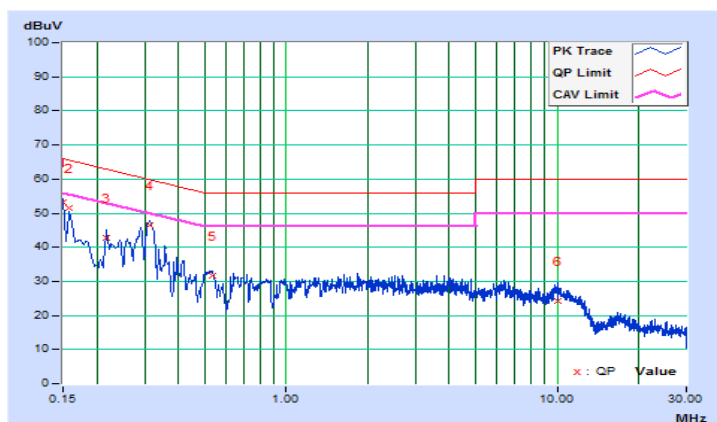

Phase	Neutral (N)	Detector Function	Quasi-Peak (QP) / Average (AV)
Test Mode	A		

No	Freq. [MHz]	Corr. Factor (dB)	Reading Value [dB (uV)]		Emission Level [dB (uV)]		Limit [dB (uV)]		Margin (dB)	
			Q.P.	AV.	Q.P.	AV.	Q.P.	AV.	Q.P.	AV.
			1	0.15400	9.66	42.58	29.64	52.24	39.30	65.78
2	0.17000	9.66	40.27	27.03	49.93	36.69	64.96	54.96	-15.03	-18.27
3	0.19989	9.66	36.09	25.25	45.75	34.91	63.62	53.62	-17.87	-18.71
4	0.29800	9.66	37.41	28.45	47.07	38.11	60.30	50.30	-13.23	-12.19
5	0.55000	9.65	23.13	18.16	32.78	27.81	56.00	46.00	-23.22	-18.19
6	7.25400	9.79	13.28	7.82	23.07	17.61	60.00	50.00	-36.93	-32.39

REMARKS:

1. Q.P. and AV. are abbreviations of quasi-peak and average individually.
2. The emission levels of other frequencies were very low against the limit.
3. Margin value = Emission level - Limit value
4. Correction factor = Insertion loss + Cable loss
5. Emission Level = Correction Factor + Reading Value.

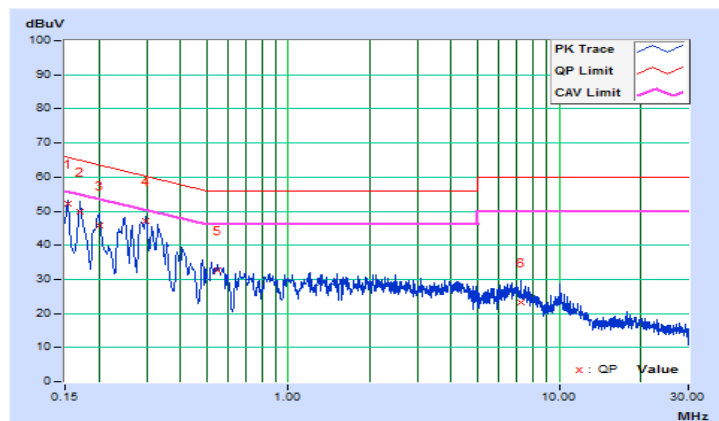

Phase	Line (L)	Detector Function	Quasi-Peak (QP) / Average (AV)
Test Mode	B		

No	Freq. [MHz]	Corr. Factor (dB)	Reading Value [dB (uV)]		Emission Level [dB (uV)]		Limit [dB (uV)]		Margin (dB)	
			Q.P.	AV.	Q.P.	AV.	Q.P.	AV.	Q.P.	AV.
			1	0.15400	9.69	36.47	25.25	46.16	34.94	65.78
2	0.17000	9.69	33.91	23.70	43.60	33.39	64.96	54.96	-21.36	-21.57
3	0.21400	9.68	27.72	17.32	37.40	27.00	63.05	53.05	-25.65	-26.05
4	0.35876	9.68	33.05	25.43	42.73	35.11	58.76	48.76	-16.03	-13.65
5	3.75400	9.74	16.03	9.79	25.77	19.53	56.00	46.00	-30.23	-26.47
6	22.71000	9.94	10.48	2.68	20.42	12.62	60.00	50.00	-39.58	-37.38

REMARKS:

1. Q.P. and AV. are abbreviations of quasi-peak and average individually.
2. The emission levels of other frequencies were very low against the limit.
3. Margin value = Emission level - Limit value
4. Correction factor = Insertion loss + Cable loss
5. Emission Level = Correction Factor + Reading Value.

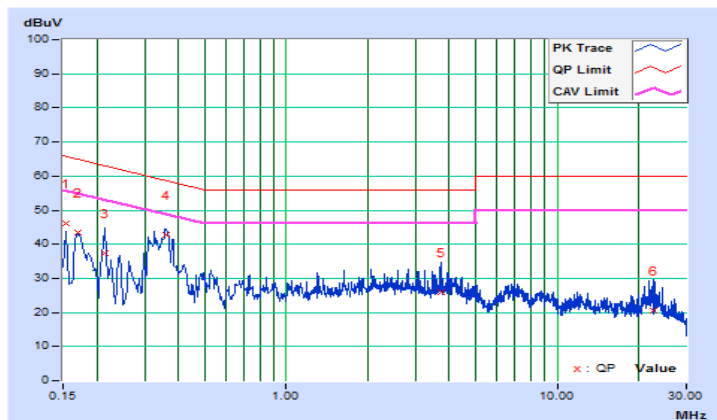

Phase	Neutral (N)	Detector Function	Quasi-Peak (QP) / Average (AV)
Test Mode	B		

No	Freq. [MHz]	Corr. Factor (dB)	Reading Value [dB (uV)]		Emission Level [dB (uV)]		Limit [dB (uV)]		Margin (dB)	
			Q.P.	AV.	Q.P.	AV.	Q.P.	AV.	Q.P.	AV.
			1	0.15811	9.66	36.23	22.86	45.89	32.52	65.56
2	0.17430	9.66	33.19	24.40	42.85	34.06	64.75	54.75	-21.90	-20.69
3	0.19728	9.66	29.55	18.79	39.21	28.45	63.72	53.72	-24.51	-25.27
4	0.36640	9.65	32.24	25.64	41.89	35.29	58.58	48.58	-16.69	-13.29
5	4.28200	9.73	15.26	7.87	24.99	17.60	56.00	46.00	-31.01	-28.40
6	9.29800	9.83	16.39	11.33	26.22	21.16	60.00	50.00	-33.78	-28.84

REMARKS:

1. Q.P. and AV. are abbreviations of quasi-peak and average individually.
2. The emission levels of other frequencies were very low against the limit.
3. Margin value = Emission level - Limit value
4. Correction factor = Insertion loss + Cable loss
5. Emission Level = Correction Factor + Reading Value.

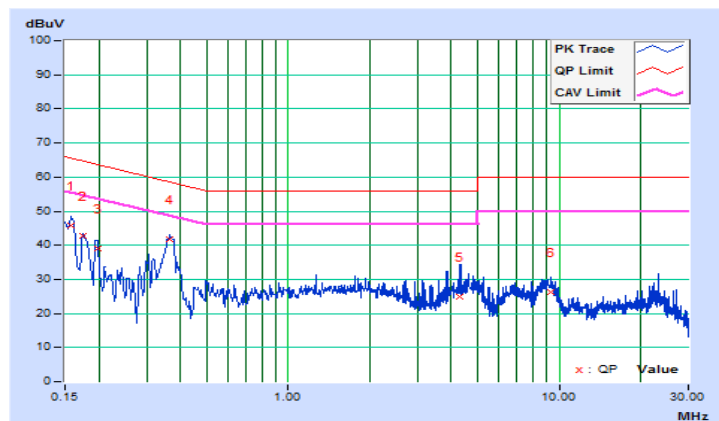

Phase	Line (L)	Detector Function	Quasi-Peak (QP) / Average (AV)
Test Mode	C		

No	Freq. [MHz]	Corr. Factor (dB)	Reading Value [dB (uV)]		Emission Level [dB (uV)]		Limit [dB (uV)]		Margin (dB)	
			Q.P.	AV.	Q.P.	AV.	Q.P.	AV.	Q.P.	AV.
			1	0.18125	9.68	27.70	19.52	37.38	29.20	64.43
2	0.27500	9.68	19.15	2.23	28.83	11.91	60.97	50.97	-32.14	-39.06
3	0.49766	9.68	24.42	19.12	34.10	28.80	56.04	46.04	-21.94	-17.24
4	1.28906	9.68	19.83	10.90	29.51	20.58	56.00	46.00	-26.49	-25.42
5	2.59375	9.71	14.57	1.57	24.28	11.28	56.00	46.00	-31.72	-34.72
6	29.67578	9.95	23.48	5.02	33.43	14.97	60.00	50.00	-26.57	-35.03

REMARKS:

1. Q.P. and AV. are abbreviations of quasi-peak and average individually.
2. The emission levels of other frequencies were very low against the limit.
3. Margin value = Emission level - Limit value
4. Correction factor = Insertion loss + Cable loss
5. Emission Level = Correction Factor + Reading Value.

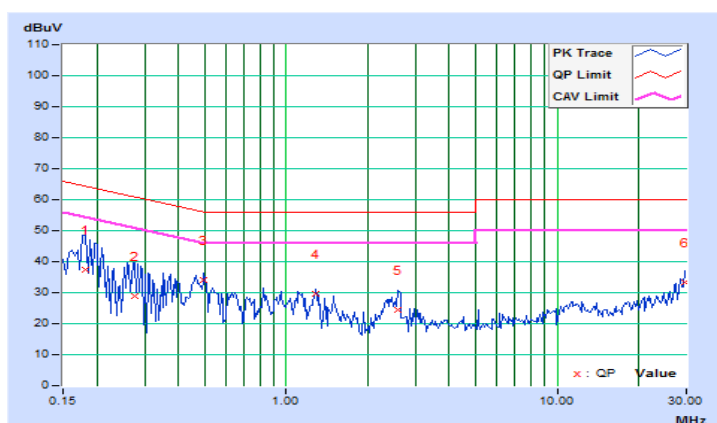

Phase	Neutral (N)	Detector Function	Quasi-Peak (QP) / Average (AV)
Test Mode	C		

No	Freq. [MHz]	Corr. Factor (dB)	Reading Value [dB (uV)]		Emission Level [dB (uV)]		Limit [dB (uV)]		Margin (dB)	
			Q.P.	AV.	Q.P.	AV.	Q.P.	AV.	Q.P.	AV.
			1	0.15391	9.66	29.84	9.84	39.50	19.50	65.79
2	0.18125	9.66	27.07	17.45	36.73	27.11	64.43	54.43	-27.70	-27.32
3	0.46250	9.65	25.34	20.33	34.99	29.98	56.65	46.65	-21.66	-16.67
4	1.31641	9.65	14.56	6.16	24.21	15.81	56.00	46.00	-31.79	-30.19
5	2.27734	9.68	16.59	1.96	26.27	11.64	56.00	46.00	-29.73	-34.36
6	28.92969	10.04	14.68	1.22	24.72	11.26	60.00	50.00	-35.28	-38.74

REMARKS:

1. Q.P. and AV. are abbreviations of quasi-peak and average individually.
2. The emission levels of other frequencies were very low against the limit.
3. Margin value = Emission level - Limit value
4. Correction factor = Insertion loss + Cable loss
5. Emission Level = Correction Factor + Reading Value.

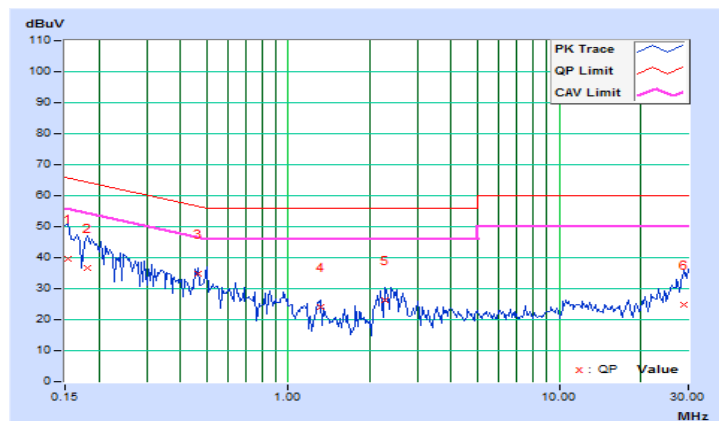

4.3 Transmit Power Measurement

4.3.1 Limits of Transmit Power Measurement

Operation Band	EUT Category		LIMIT
U-NII-1		Outdoor Access Point	1 Watt (30 dBm) (Max. e.i.r.p \leq 125mW(21 dBm) at any elevation angle above 30 degrees as measured from the horizon)
		Fixed point-to-point Access Point	1 Watt (30 dBm)
	√	Indoor Access Point	1 Watt (30 dBm)
		Mobile and Portable client device	250mW (24 dBm)
U-NII-2A	-		250mW (24 dBm) or 11 dBm+10 log B*
U-NII-2C	-		250mW (24 dBm) or 11 dBm+10 log B*
U-NII-3	√		1 Watt (30 dBm)

*B is the 26 dB emission bandwidth in megahertz

Per KDB 662911 Method of conducted output power measurement on IEEE 802.11 devices,

Array Gain = 0 dB (i.e., no array gain) for $N_{ANT} \leq 4$;

Array Gain = 0 dB (i.e., no array gain) for channel widths ≥ 40 MHz for any N_{ANT} ;

Array Gain = $5 \log(N_{ANT}/N_{SS})$ dB or 3 dB, whichever is less for 20-MHz channel widths with $N_{ANT} \geq 5$.

For power measurements on all other devices: Array Gain = $10 \log(N_{ANT}/N_{SS})$ dB.

4.3.2 Test Setup

For Power Output

802.11a, 802.11n (HT20), 802.11n (HT40)

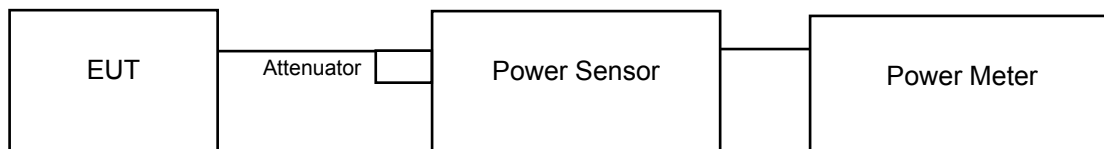

802.11ac (VHT80)

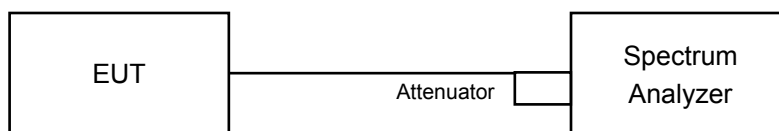

For 26dB Bandwidth

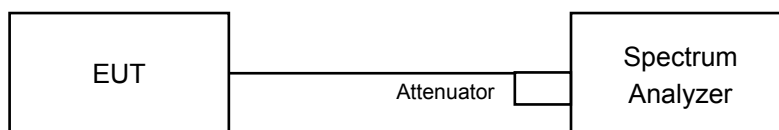

4.3.3 Test Instruments

Refer to section 4.1.2 to get information of above instrument.

4.3.4 Test Procedure

For Average Power Measurement

For 802.11a, 802.11n (HT20), 802.11n (HT40)

Method PM is used to perform output power measurement, trigger and gating function of wide band power meter is enabled to measure max output power of TX on burst. Duty factor is not added to measured value.

For 802.11ac (VHT80), 802.11ac (VHT80+VHT80)

- a. Set span to encompass the entire 26 dB EBW (or, alternatively, the entire 99% occupied bandwidth) of the signal.
- b. Set sweep trigger to "free run".
- c. Set RBW = 1 MHz
- d. Set VBW \geq 3 MHz
- e. Number of points in sweep \geq 2 Span / RBW
- f. Sweep time \leq (number of points in sweep) * T
- g. Using emission bandwidth to determine the frequency span for integration the channel bandwidth.
- h. Detector = RMS
- i. Trace mode = max hold
- j. Allow max hold to run for at least 60 seconds, or longer as needed to allow the trace to stabilize.
- k. Compute power by integrating the spectrum across the EBW (or, alternatively, the entire 99% occupied bandwidth) of the signal using the instrument's band power measurement function with band limits set equal to the EBW (or occupied bandwidth) band edges. If the instrument does not have a band power function, sum the spectrum levels (in power units) at 1 MHz intervals extending across the EBW (or, alternatively, the entire 99% occupied bandwidth) of the spectrum.

For 26dB Bandwidth

- a. Set RBW = approximately 1% of the emission bandwidth.
- b. Set the VBW > RBW.
- c. Detector = Peak.
- d. Trace mode = max hold.
- e. Measure the maximum width of the emission that is 26 dB down from the peak of the emission. Compare this with the RBW setting of the analyzer. Readjust RBW and repeat measurement as needed until the RBW/EBW ratio is approximately 1%.

4.3.5 Deviation from Test Standard

No deviation.

4.3.6 EUT Operating Conditions

The software provided by client to enable the EUT under transmission condition continuously at lowest, middle and highest channel frequencies individually.

4.3.7 Test Result

Power Output:

CDD Mode

802.11a

Channel	Freq. (MHz)	Maximum Conducted Power (dBm)				Total Power (mW)	Total Power (dBm)	Limit (dBm)	Pass / Fail
		Chain 0	Chain 1	Chain 2	Chain 3				
36	5180	19.84	19.78	19.57	19.49	370.936	25.69	30.00	Pass
40	5200	19.70	19.86	19.22	19.89	371.212	25.70	30.00	Pass
48	5240	19.74	19.82	19.23	19.72	367.638	25.65	30.00	Pass
149	5745	23.94	23.36	23.34	23.42	900.072	29.54	30.00	Pass
157	5785	24.23	23.37	23.38	23.51	924.279	29.66	30.00	Pass
165	5825	24.20	23.30	23.06	23.42	898.911	29.54	30.00	Pass

802.11n (HT20)

Channel	Freq. (MHz)	Maximum Conducted Power (dBm)				Total Power (mW)	Total Power (dBm)	Limit (dBm)	Pass / Fail
		Chain 0	Chain 1	Chain 2	Chain 3				
36	5180	19.91	19.98	19.79	19.72	386.526	25.87	30.00	Pass
40	5200	20.17	20.37	19.78	20.14	411.221	26.14	30.00	Pass
48	5240	20.12	20.18	19.70	20.14	403.635	26.06	30.00	Pass
149	5745	24.05	23.38	23.30	23.26	897.500	29.53	30.00	Pass
157	5785	24.12	23.31	23.21	23.38	899.697	29.54	30.00	Pass
165	5825	24.33	23.12	23.03	23.51	901.432	29.55	30.00	Pass

802.11n (HT40)

Channel	Freq. (MHz)	Maximum Conducted Power (dBm)				Total Power (mW)	Total Power (dBm)	Limit (dBm)	Pass / Fail
		Chain 0	Chain 1	Chain 2	Chain 3				
38	5190	16.89	17.03	16.78	16.92	196.178	22.93	30.00	Pass
46	5230	22.43	22.59	22.10	22.42	693.300	28.41	30.00	Pass
151	5755	23.62	23.13	23.07	22.86	831.698	29.20	30.00	Pass
159	5795	24.19	23.21	23.14	23.42	897.682	29.53	30.00	Pass

802.11ac (VHT80)

Channel	Freq. (MHz)	Maximum Conducted Power (dBm)				Total Power (mW)	Total Power (dBm)	Limit (dBm)	Pass / Fail
		Chain 0	Chain 1	Chain 2	Chain 3				
42	5210	16.57	16.59	16.25	16.41	176.92	22.48	30.00	Pass
155	5775	18.94	18.24	18.25	18.15	277.171	24.43	30.00	Pass

802.11ac (VHT80+VHT80)

Channel	Freq. (MHz)	Maximum Conducted Power (dBm)				Total Power (mW)	Total Power (dBm)	Limit (dBm)	Pass / Fail
		Chain 0	Chain 1	Chain 2	Chain 3				
42	5210	16.33	16.32	-	-	85.809	19.34	30.00	Pass
155	5775	-	-	16.82	16.75	95.399	19.80	30.00	Pass

Beamforming Mode

802.11n (HT20)

Channel	Freq. (MHz)	Maximum Conducted Power (dBm)				Total Power (mW)	Total Power (dBm)	Limit (dBm)	Pass / Fail
		Chain 0	Chain 1	Chain 2	Chain 3				
36	5180	18.53	18.60	18.41	18.34	281.306	24.49	28.99	Pass
40	5200	18.79	18.99	18.40	18.76	299.278	24.76	28.99	Pass
48	5240	18.74	18.80	18.32	18.76	293.757	24.68	28.99	Pass
149	5745	22.67	22.00	21.92	21.88	653.183	28.15	28.99	Pass
157	5785	22.74	21.93	21.83	22.00	654.781	28.16	28.99	Pass
165	5825	22.95	21.74	21.65	22.13	656.044	28.17	28.99	Pass

Note:

1. The antenna is cross-polarized antenna.
2. Gain= 4dBi +10log (2) = 7.01 > 6dBi, so the power limit shall be reduced to 30-(7.01-6) = 28.99dBm.

802.11n (HT40)

Channel	Freq. (MHz)	Maximum Conducted Power (dBm)				Total Power (mW)	Total Power (dBm)	Limit (dBm)	Pass / Fail
		Chain 0	Chain 1	Chain 2	Chain 3				
38	5190	15.51	15.65	15.40	15.54	142.775	21.55	28.99	Pass
46	5230	21.05	21.21	20.72	21.04	504.569	27.03	28.99	Pass
151	5755	22.24	21.75	21.69	21.48	605.294	27.82	28.99	Pass
159	5795	22.81	21.83	21.76	22.04	653.314	28.15	28.99	Pass

Note:

1. The antenna is cross-polarized antenna.
2. Gain= 4dBi +10log (2) = 7.01 > 6dBi, so the power limit shall be reduced to 30-(7.01-6) = 28.99dBm.

802.11ac (VHT80)

Channel	Freq. (MHz)	Maximum Conducted Power (dBm)				Total Power (mW)	Total Power (dBm)	Limit (dBm)	Pass / Fail
		Chain 0	Chain 1	Chain 2	Chain 3				
42	5210	15.19	15.21	14.87	15.03	128.758	21.10	28.99	Pass
155	5775	17.56	16.86	16.87	16.77	201.720	23.05	28.99	Pass

Note:

1. The antenna is cross-polarized antenna.
2. Gain= 4dBi +10log (2) = 7.01 > 6dBi, so the power limit shall be reduced to 30-(7.01-6) = 28.99dBm.

26dB Bandwidth:

802.11a

Channel	Frequency (MHz)	26dBc Bandwidth (MHz)			
		Chain 0	Chain 1	Chain 2	Chain 3
36	5180	20.10	19.93	19.91	20.15
40	5200	20.10	19.89	19.95	20.08
48	5240	19.95	19.95	19.81	20.04

802.11n (HT20)

Channel	Frequency (MHz)	26dBc Bandwidth (MHz)			
		Chain 0	Chain 1	Chain 2	Chain 3
36	5180	20.54	20.82	20.57	20.73
40	5200	20.53	20.66	20.61	20.51
48	5240	20.55	20.77	20.63	20.64

802.11n (HT40)

Channel	Frequency (MHz)	26dBc Bandwidth (MHz)			
		Chain 0	Chain 1	Chain 2	Chain 3
38	5190	40.52	40.53	41.03	40.87
46	5230	40.69	40.48	40.88	41.12

802.11ac (VHT80)

Channel	Frequency (MHz)	26dBc Bandwidth (MHz)			
		Chain 0	Chain 1	Chain 2	Chain 3
42	5210	83.49	84.20	83.95	83.93

802.11ac (VHT80+VHT80)

Channel	Frequency (MHz)	26dBc Bandwidth (MHz)			
		Chain 0	Chain 1	Chain 2	Chain 3
42+	5210	83.67	84.40	-	-
155	5775	-	-	83.62	84.19

Spectrum Plot of Worst Value

802.11a

802.11n (HT20)

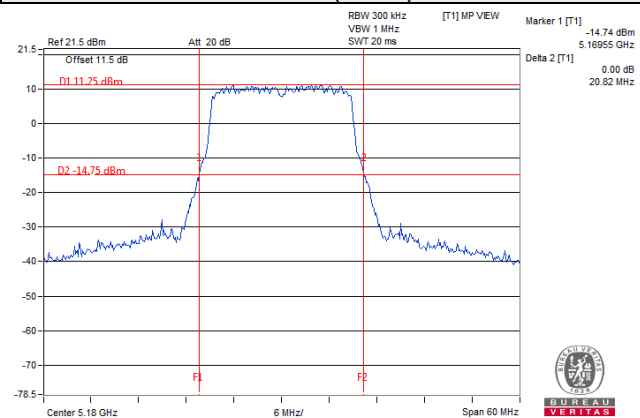
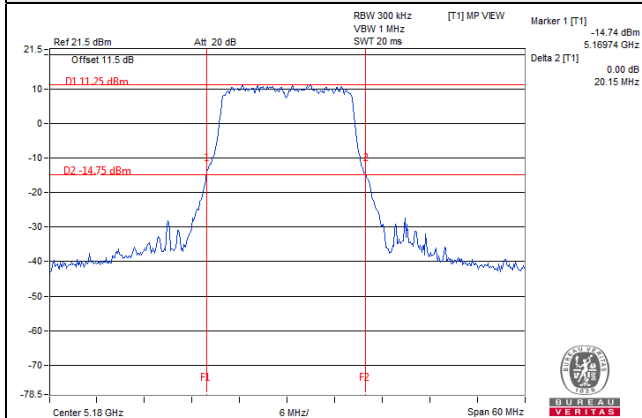

802.11n (HT40)

802.11ac (VHT80)

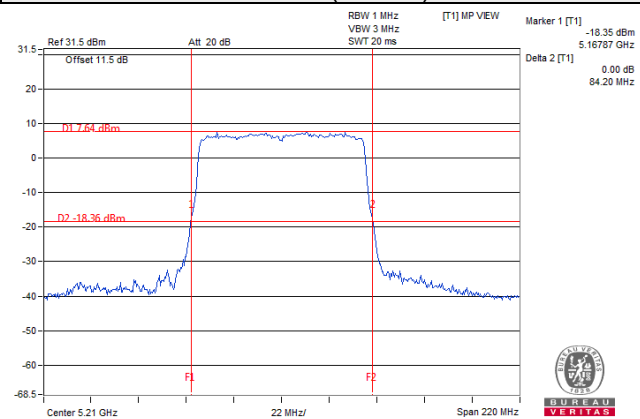
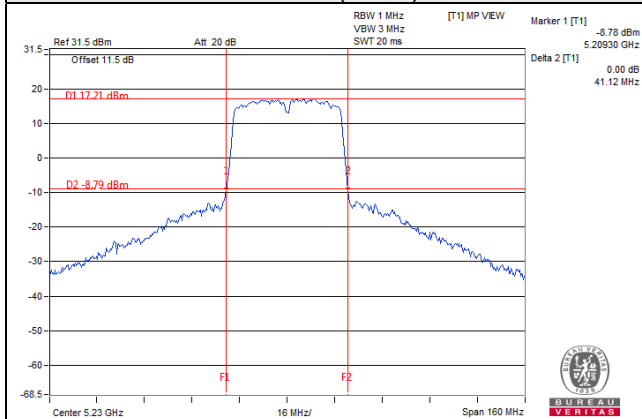

802.11ac (VHT80+VHT80)

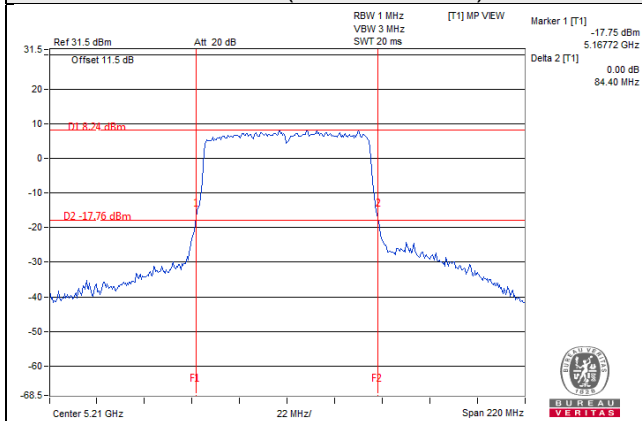

4.4 Occupied Bandwidth Measurement

4.4.1 Test Setup

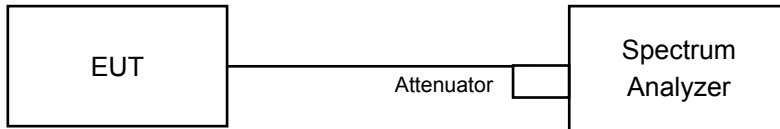

4.4.2 Test Instruments

Refer to section 4.1.2 to get information of above instrument.

4.4.3 Test Procedure

The transmitter output was connected to the spectrum analyzer through an attenuator. The bandwidth of the fundamental frequency was measured by spectrum analyzer with resolution bandwidth in the range of 1% to 5% of the anticipated emission bandwidth, and a video bandwidth at least 3x the resolution bandwidth and set the detector to sampling. The width of a frequency band such that, below the lower and above the upper frequency limits, the mean powers emitted are each equal to a specified percentage 0.5 %of the total mean power of a given emission.

4.4.4 Test Result

802.11a

Channel	Frequency (MHz)	Occupied Bandwidth (MHz)			
		Chain 0	Chain 1	Chain 2	Chain 3
36	5180	16.44	16.44	16.56	16.44
40	5200	16.44	16.44	16.44	16.44
48	5240	16.44	16.44	16.44	16.44
149	5745	16.56	16.44	16.56	16.68
157	5785	16.44	16.44	16.56	16.80
165	5825	16.44	16.56	16.44	16.56

802.11n (HT20)

Channel	Frequency (MHz)	Occupied Bandwidth (MHz)			
		Chain 0	Chain 1	Chain 2	Chain 3
36	5180	17.64	17.64	17.64	17.64
40	5200	17.64	17.64	17.64	17.64
48	5240	17.64	17.64	17.64	17.64
149	5745	17.64	17.64	17.64	17.76
157	5785	17.64	17.64	17.64	17.64
165	5825	17.64	17.64	17.64	17.76

802.11n (HT40)

Channel	Frequency (MHz)	Occupied Bandwidth (MHz)			
		Chain 0	Chain 1	Chain 2	Chain 3
38	5190	36.12	36.12	36.24	36.12
46	5230	36.12	36.00	36.12	36.12
151	5755	36.12	36.12	36.24	36.12
159	5795	36.00	36.12	36.24	36.24

802.11ac (VHT80)

Channel	Frequency (MHz)	Occupied Bandwidth (MHz)			
		Chain 0	Chain 1	Chain 2	Chain 3
42	5210	75.84	76.08	76.08	75.84
155	5775	75.84	76.08	76.08	75.84

802.11ac (VHT80+VHT80)

Channel	Frequency (MHz)	Occupied Bandwidth (MHz)			
		Chain 0	Chain 1	Chain 2	Chain 3
42	5210	76.32	76.56	-	-
155	5775	-	-	75.66	76.00

Spectrum Plot of Worst Value

802.11a

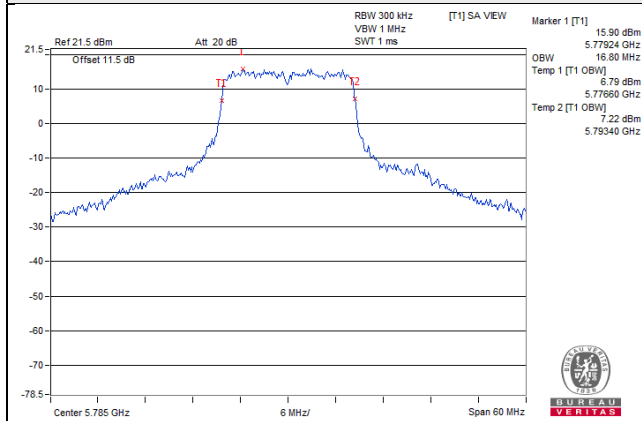

802.11n (HT20)

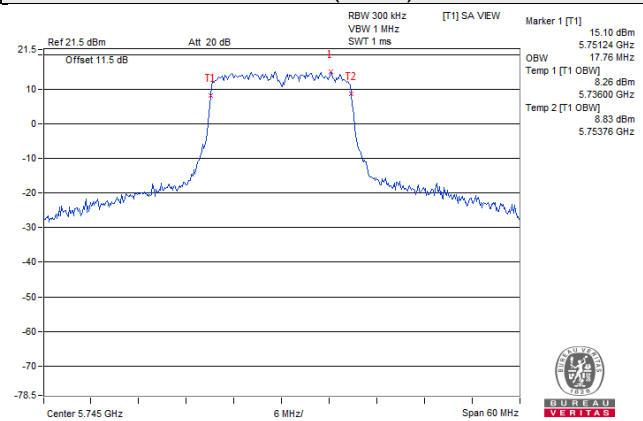

802.11n (HT40)

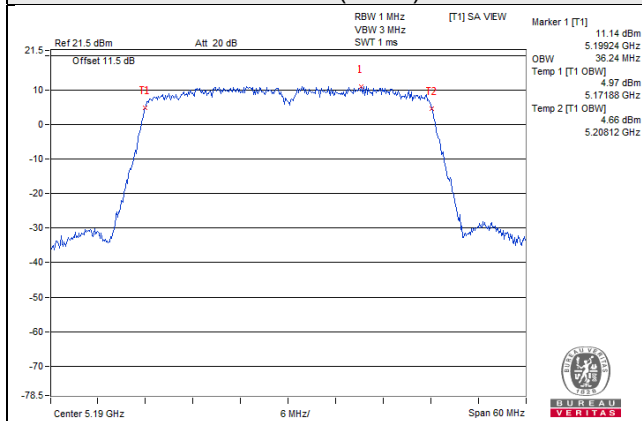

802.11ac (VHT80)

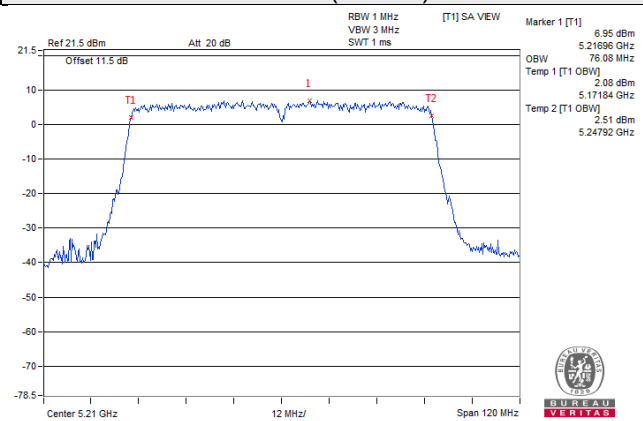

802.11ac (VHT80+VHT80)

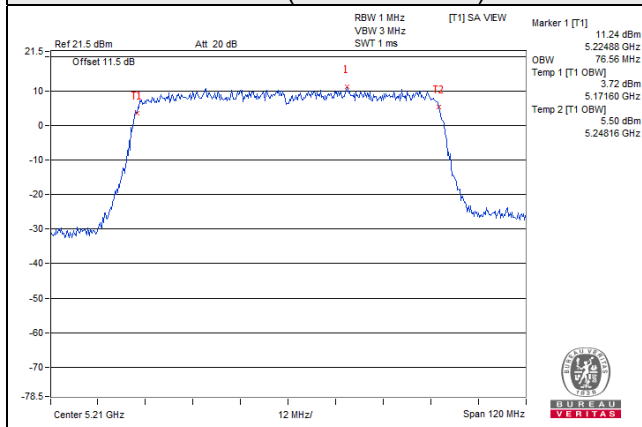

4.5 Peak Power Spectral Density Measurement

4.5.1 Limits of Peak Power Spectral Density Measurement

Operation Band	EUT Category		LIMIT
U-NII-1		Outdoor Access Point	17dBm/ MHz
		Fixed point-to-point Access Point	
	√	Indoor Access Point	
		Mobile and Portable client device	11dBm/ MHz
U-NII-2A	-		11dBm/ MHz
U-NII-2C	-		11dBm/ MHz
U-NII-3	√		30dBm/ 500kHz

4.5.2 Test Setup

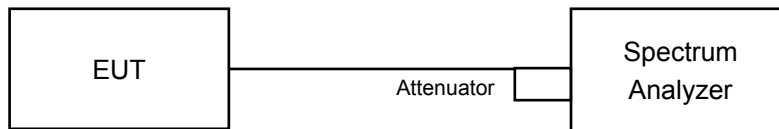

4.5.3 Test Instruments

Refer to section 4.1.2 to get information of above instrument.

4.5.4 Test Procedures

For U-NII-1band:

Duty cycle of test signal is $\geq 98\%$

Using method SA-1

- 1) Set span to encompass the entire emission bandwidth (EBW) of the signal.
- 2) Set RBW = 1MHz, Set VBW ≥ 3 MHz, Detector = RMS
- 3) Set Channel power measure = 1MHz
- 4) Sweep time = auto, trigger set to "free run".
- 5) Trace average at least 100 traces in power averaging mode.
- 6) Record the max value

Using method SA-2, Duty cycle $<98\%$

- 1) Set span to encompass the entire emission bandwidth (EBW) of the signal.
- 2) Set RBW = 30 kHz, Set VBW ≥ 1 MHz, Detector = RMS
- 3) Set Channel power measure = 1MHz
- 4) Sweep time = auto, trigger set to "free run".
- 5) Trace average at least 100 traces in power averaging mode.
- 6) Record the max value and add $10 \log (1/\text{duty cycle})$

For U-NII-3 band:

Duty cycle of test signal is $\geq 98\%$

- 1) Set span to encompass the entire emission bandwidth (EBW) of the signal.
- 2) Set RBW = 300 kHz, Set VBW ≥ 1 MHz, Detector = RMS.
- 3) Use the peak marker function to determine the maximum power level in any 300 kHz band segment within the fundamental EBW.
- 4) Scale the observed power level to an equivalent value in 500 kHz by adjusting (reducing) the measured power by a bandwidth correction factor (BWCF) where $\text{BWCF} = 10\log(500 \text{ kHz} / 300 \text{ kHz})$.
- 5) Sweep time = auto, trigger set to "free run".
- 6) Trace average at least 100 traces in power averaging mode.
- 7) Record the max value.

Duty cycle $<98\%$

- 1) Set span to encompass the entire emission bandwidth (EBW) of the signal.
- 2) Set RBW = 300 kHz, Set VBW ≥ 1 MHz, Detector = RMS
- 3) Use the peak marker function to determine the maximum power level in any 300 kHz band segment within the fundamental EBW.
- 4) Scale the observed power level to an equivalent value in 500 kHz by adjusting (reducing) the measured power by a bandwidth correction factor (BWCF) where $\text{BWCF} = 10\log(500 \text{ kHz}/300\text{kHz})$
- 5) Sweep time = auto, trigger set to "free run".
- 6) Trace average at least 100 traces in power averaging mode.
- 7) Record the max value and add $10 \log (1/\text{duty cycle})$

4.5.5 Deviation from Test Standard

No deviation.

4.5.6 EUT Operating Conditions

Same as 4.3.6.

4.5.7 Test Results

For U-NII-1 Band

802.11a

Chan.	Freq. (MHz)	PSD (dBm)				Duty factor (dB)	Total PSD with duty factor (dBm/MHz)	Max. Limit (dBm/MHz)	Pass / Fail
		Chain 0	Chain 1	Chain 2	Chain 3				
36	5180	6.38	6.30	6.81	6.41	0.16	12.66	15.99	Pass
40	5200	6.73	6.59	6.34	6.46	0.16	12.71	15.99	Pass
48	5240	6.54	6.56	6.47	6.47	0.16	12.69	15.99	Pass

Note:

- Method 1 of power density measurement of KDB 662911 is using for calculating total power density. Total power density is summing entire spectra across corresponding frequency bins on the various outputs by computer.
- For U-NII-1:**
The antenna is cross-polarized antenna.
Directional gain = $4\text{dBi} + 10\log(2) = 7.01\text{dBi} > 6\text{dBi}$, so the power density limit shall be reduced to $17 - (7.01 - 6) = 15.99\text{dBm}$.
- Refer to section 3.3 for duty cycle spectrum plot.

802.11n (HT20)

Chan.	Freq. (MHz)	PSD (dBm)				Total PSD (dBm/MHz)	Max. Limit (dBm/MHz)	Pass / Fail
		Chain 0	Chain 1	Chain 2	Chain 3			
36	5180	6.65	6.19	6.87	6.40	12.56	15.99	Pass
40	5200	6.64	6.14	7.02	6.47	12.60	15.99	Pass
48	5240	6.62	6.09	6.82	6.55	12.55	15.99	Pass

Note:

- Method 1 of power density measurement of KDB 662911 is using for calculating total power density. Total power density is summing entire spectra across corresponding frequency bins on the various outputs by computer.
- For U-NII-1:**
The antenna is cross-polarized antenna.
Directional gain = $4\text{dBi} + 10\log(2) = 7.01\text{dBi} > 6\text{dBi}$, so the power density limit shall be reduced to $17 - (7.01 - 6) = 15.99\text{dBm}$.

802.11n (HT40)

Chan.	Freq. (MHz)	PSD (dBm)				Duty factor (dB)	Total PSD with duty factor (dBm/MHz)	Max. Limit (dBm/MHz)	Pass / Fail
		Chain 0	Chain 1	Chain 2	Chain 3				
38	5190	0.63	0.41	1.27	0.90	0.19	7.03	15.99	Pass
46	5230	6.61	6.46	6.43	6.60	0.19	12.74	15.99	Pass

Note:

- Method 1 of power density measurement of KDB 662911 is using for calculating total power density. Total power density is summing entire spectra across corresponding frequency bins on the various outputs by computer.
- For U-NII-1:**
The antenna is cross-polarized antenna.
Directional gain = 4dBi + 10log (2) = 7.01dBi > 6dBi, so the power density limit shall be reduced to 17-(7.01-6) = 15.99dBm.
- Refer to section 3.3 for duty cycle spectrum plot.

802.11ac (VHT80)

Chan.	Freq. (MHz)	PSD (dBm)				Duty factor (dB)	Total PSD with duty factor (dBm/MHz)	Max. Limit (dBm/MHz)	Pass / Fail
		Chain 0	Chain 1	Chain 2	Chain 3				
42	5210	-3.20	-3.52	-2.45	-3.09	0.28	3.25	15.99	Pass

Note:

- Method 1 of power density measurement of KDB 662911 is using for calculating total power density. Total power density is summing entire spectra across corresponding frequency bins on the various outputs by computer.
- For U-NII-1:**
The antenna is cross-polarized antenna.
Directional gain = 4dBi + 10log (2) = 7.01dBi > 6dBi, so the power density limit shall be reduced to 17-(7.01-6) = 15.99dBm.
- Refer to section 3.3 for duty cycle spectrum plot.

802.11ac (VHT80+VHT80)

Chan.	Freq. (MHz)	PSD (dBm)				Duty factor (dB)	Total PSD with duty factor (dBm/MHz)	Max. Limit (dBm/MHz)	Pass / Fail
		Chain 0	Chain 1	Chain 2	Chain 3				
42	5210	-2.80	-2.67	-	-	0.28	0.55	15.99	Pass

Note:

- Method 1 of power density measurement of KDB 662911 is using for calculating total power density. Total power density is summing entire spectra across corresponding frequency bins on the various outputs by computer.
- For U-NII-1:**
The antenna is cross-polarized antenna.
Directional gain = 4dBi + 10log (2) = 7.01dBi > 6dBi, so the power density limit shall be reduced to 17-(7.01-6) = 15.99dBm.
- Refer to section 3.3 for duty cycle spectrum plot.

Spectrum Plot of Worst Value

802.11a / Chain 2 / Ch 36

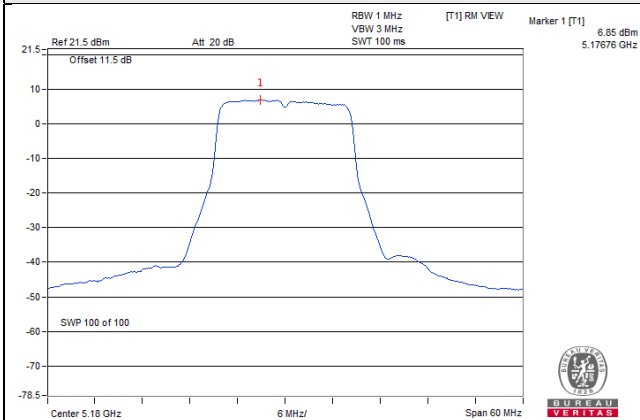

802.11n (HT20) / Chain 2 / Ch 40

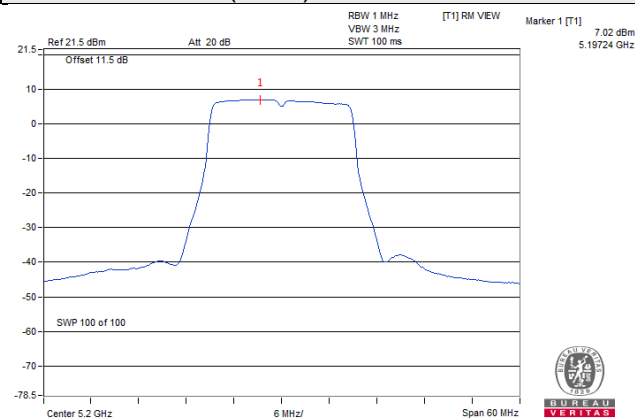

802.11n (HT40) / Chain 0 / Ch 46

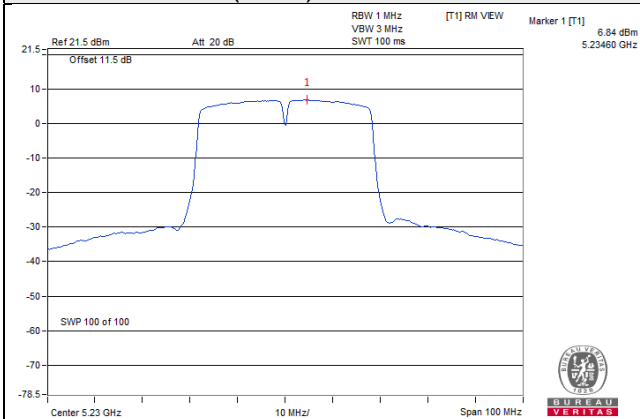

802.11ac (VHT80) / Chain 2 / Ch 42

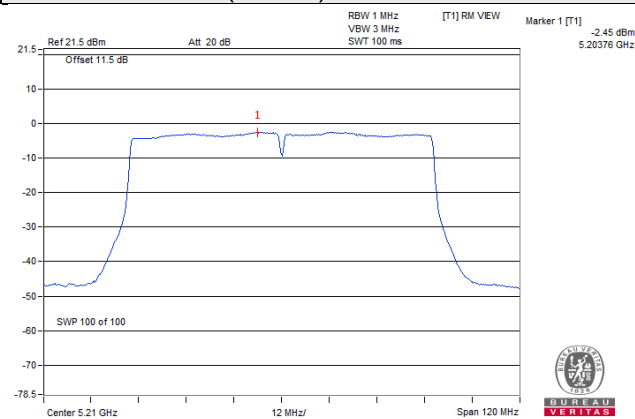

802.11ac (VHT80+VHT80) / Chain 1 / Ch 42

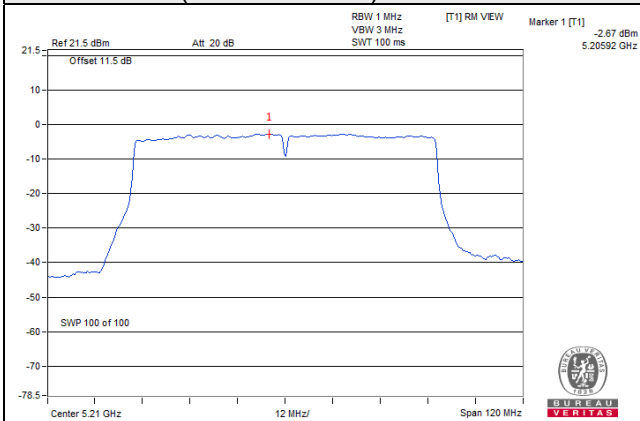

For U-NII-3 band:
802.11a

TX chain	Channel	Chan. Freq. (MHz)	PSD W/O Duty Factor		10 log (N=4) dB	Duty factor (dB)	Total PSD With Duty Factor (dBm/500kHz)	Limit (dBm/500kHz)	Pass / Fail
			(dBm/300kHz)	(dBm/500kHz)					
0	149	5745	2.39	4.61	6.02	0.16	10.79	25.98	Pass
	157	5785	2.50	4.72	6.02	0.16	10.90	25.98	Pass
	165	5825	2.28	4.50	6.02	0.16	10.68	25.98	Pass
1	149	5745	2.31	4.53	6.02	0.16	10.71	25.98	Pass
	157	5785	2.05	4.27	6.02	0.16	10.45	25.98	Pass
	165	5825	1.56	3.78	6.02	0.16	9.96	25.98	Pass
2	149	5745	2.55	4.77	6.02	0.16	10.95	25.98	Pass
	157	5785	2.38	4.60	6.02	0.16	10.78	25.98	Pass
	165	5825	2.22	4.44	6.02	0.16	10.62	25.98	Pass
3	149	5745	2.87	5.09	6.02	0.16	11.27	25.98	Pass
	157	5785	3.05	5.27	6.02	0.16	11.45	25.98	Pass
	165	5825	2.89	5.11	6.02	0.16	11.29	25.98	Pass

Note:

- Method 1 of power density measurement of KDB 662911 is using for calculating total power density. Total power density is summing entire spectra across corresponding frequency bins on the various outputs by computer.
- For U-NII-3:** Directional gain = 4dBi + 10log (4) = 10.02dBi > 6dBi, so the power density limit shall be reduced to 30-(10.02-6) = 25.98dBm.
- Refer to section 3.3 for duty cycle spectrum plot.

802.11n (HT20)

TX chain	Channel	Freq. (MHz)	PSD		10 log (N=4) dB	Total PSD (dBm/500kHz)	Limit (dBm/500kHz)	Pass / Fail
			(dBm/300kHz)	(dBm/500kHz)				
0	149	5745	2.21	4.43	6.02	10.45	25.98	Pass
	157	5785	2.28	4.50	6.02	10.52	25.98	Pass
	165	5825	1.93	4.15	6.02	10.17	25.98	Pass
1	149	5745	2.02	4.24	6.02	10.26	25.98	Pass
	157	5785	1.68	3.90	6.02	9.92	25.98	Pass
	165	5825	1.50	3.72	6.02	9.74	25.98	Pass
2	149	5745	2.38	4.60	6.02	10.62	25.98	Pass
	157	5785	2.07	4.29	6.02	10.31	25.98	Pass
	165	5825	1.94	4.16	6.02	10.18	25.98	Pass
3	149	5745	2.49	4.71	6.02	10.73	25.98	Pass
	157	5785	2.52	4.74	6.02	10.76	25.98	Pass
	165	5825	2.59	4.81	6.02	10.83	25.98	Pass

Note:

- Method 1 of power density measurement of KDB 662911 is using for calculating total power density. Total power density is summing entire spectra across corresponding frequency bins on the various outputs by computer.
- For U-NII-3:** Directional gain = 4dBi + 10log (4) = 10.02dBi > 6dBi, so the power density limit shall be reduced to 30-(10.02-6) = 25.98dBm.

802.11n (HT40)

TX chain	Channel	Chan. Freq. (MHz)	PSD W/O Duty Factor		10 log (N=4) dB	Duty factor (dB)	Total PSD With Duty Factor (dBm/500kHz)	Limit (dBm/500kHz)	Pass / Fail
			(dBm/300kHz)	(dBm/500kHz)					
0	151	5755	-1.05	1.17	6.02	0.19	7.38	25.98	Pass
	159	5795	-0.84	1.38	6.02	0.19	7.59	25.98	Pass
1	151	5755	-1.32	0.90	6.02	0.19	7.11	25.98	Pass
	159	5795	-1.27	0.95	6.02	0.19	7.16	25.98	Pass
2	151	5755	-1.06	1.16	6.02	0.19	7.37	25.98	Pass
	159	5795	-1.10	1.12	6.02	0.19	7.33	25.98	Pass
3	151	5755	-0.67	1.55	6.02	0.19	7.76	25.98	Pass
	159	5795	-0.51	1.71	6.02	0.19	7.92	25.98	Pass

Note:

- Method 1 of power density measurement of KDB 662911 is using for calculating total power density. Total power density is summing entire spectra across corresponding frequency bins on the various outputs by computer.
- For U-NII-3:** Directional gain = 4dBi + 10log (4) = 10.02dBi > 6dBi, so the power density limit shall be reduced to 30-(10.02-6) = 25.98dBm.
- Refer to section 3.3 for duty cycle spectrum plot.

802.11ac (VHT80)

TX chain	Channel	Chan. Freq. (MHz)	PSD W/O Duty Factor		10 log (N=4) dB	Duty factor (dB)	Total PSD With Duty Factor (dBm/500kHz)	Limit (dBm/500kHz)	Pass / Fail
			(dBm/300kHz)	(dBm/500kHz)					
0	155	5775	-9.51	-7.29	6.02	0.28	-0.99	25.98	Pass
1	155	5775	-9.82	-7.60	6.02	0.28	-1.30	25.98	Pass
2	155	5775	-9.21	-6.99	6.02	0.28	-0.69	25.98	Pass
3	155	5775	-8.81	-6.59	6.02	0.28	-0.29	25.98	Pass

Note:

- Method 1 of power density measurement of KDB 662911 is using for calculating total power density. Total power density is summing entire spectra across corresponding frequency bins on the various outputs by computer.
- For U-NII-3:** Directional gain = 4dBi + 10log (4) = 10.02dBi > 6dBi, so the power density limit shall be reduced to 30-(10.02-6) = 25.98dBm.
- Refer to section 3.3 for duty cycle spectrum plot.

802.11ac (VHT80+VHT80)

TX chain	Channel	Chan. Freq. (MHz)	PSD W/O Duty Factor		10 log (N=2) dB	Duty factor (dB)	Total PSD With Duty Factor (dBm/500kHz)	Limit (dBm/500kHz)	Pass / Fail
			(dBm/300kHz)	(dBm/500kHz)					
2	155	5775	-10.56	-8.34	3.01	0.28	-5.05	28.99	Pass
3	155	5775	-10.68	-8.46	3.01	0.28	-5.17	28.99	Pass

Note:

- Method 1 of power density measurement of KDB 662911 is using for calculating total power density. Total power density is summing entire spectra across corresponding frequency bins on the various outputs by computer.
- For U-NII-3:** Directional gain = 4dBi + 10log (4/2) = 7.01dBi > 6dBi, so the power density limit shall be reduced to 30-(7.01-6) = 28.99dBm.
- Refer to section 3.3 for duty cycle spectrum plot.

Spectrum Plot of Worst Value

802.11a

802.11n (HT20)

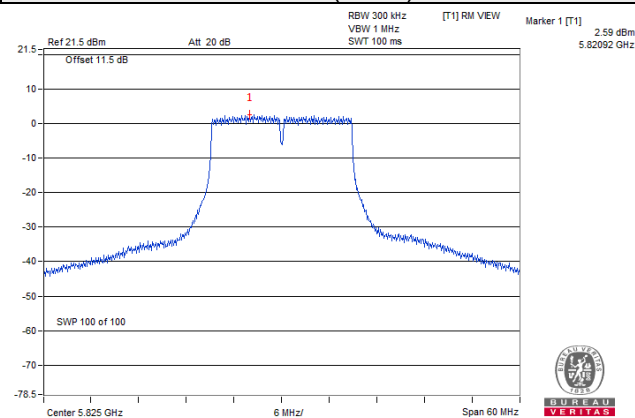
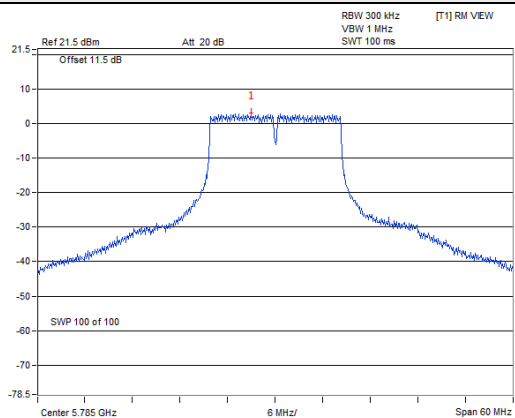

802.11n (HT40)

802.11ac (VHT80)

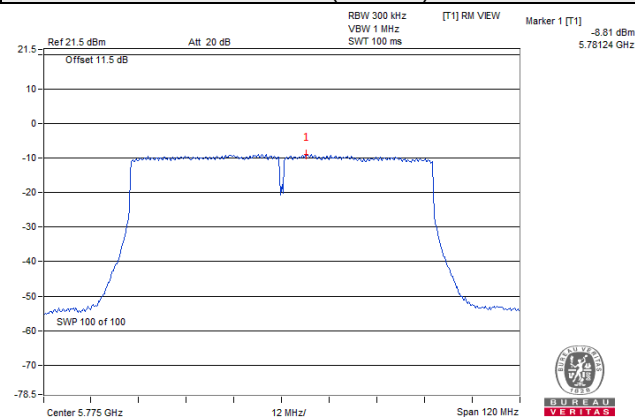
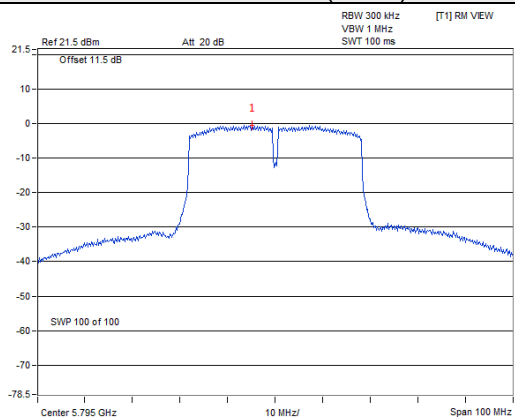

802.11ac (VHT80+VHT80)

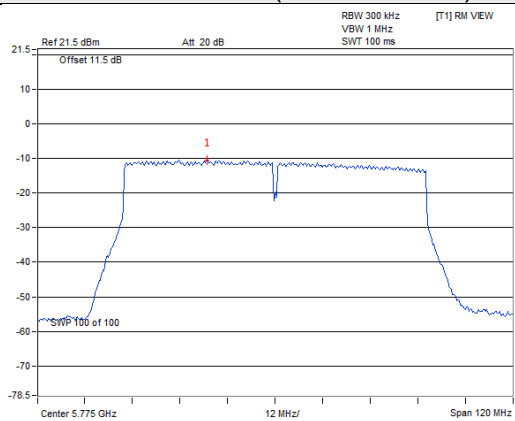

4.6 Frequency Stability

4.6.1 Limits of Frequency Stability Measurement

The frequency of the carrier signal shall be maintained within band of operation

4.6.2 Test Setup

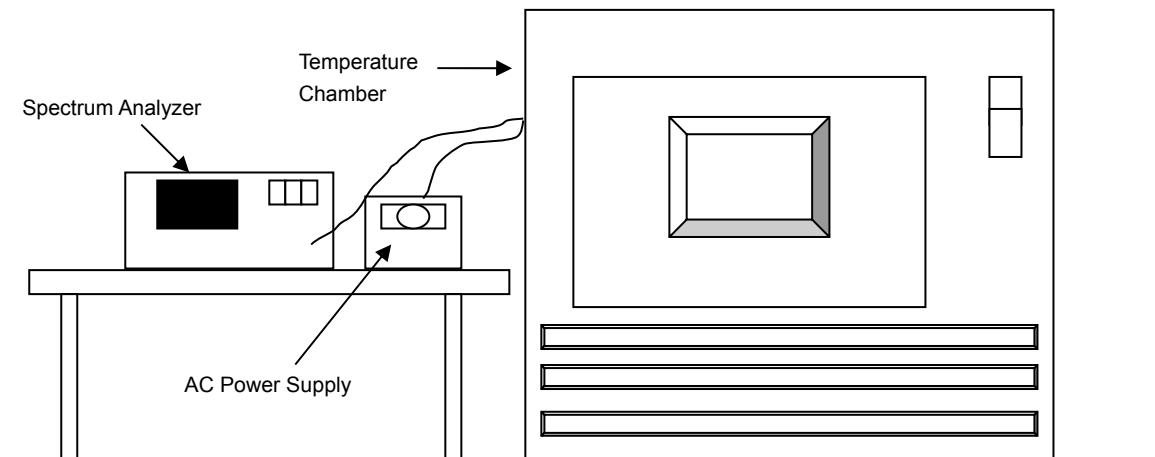

4.6.3 Test Instruments

Tested date: Jun. 13, 2018

Description & Manufacturer	Model No.	Serial No.	Cal. Date	Cal. Due
Spectrum Analyzer ROHDE & SCHWARZ	FSP40	100040	Aug. 18, 2017	Aug. 17, 2018
WIT Standard Temperature And Humidity Chamber	TH-4S-C	W981030	Jun. 04, 2018	Jun. 03, 2019
Digital Multimeter Fluke	87-III	70360742	Jun. 30, 2017	Jun. 29, 2018
AC Power Supply Exttech	CFW-105	E000603	NA	NA

4.6.4 Test Procedure

- The EUT was placed inside the environmental test chamber and powered by nominal AC voltage.
- Turn the EUT on and couple its output to a spectrum analyzer.
- Turn the EUT off and set the chamber to the highest temperature specified.
- Allow sufficient time (approximately 30 min) for the temperature of the chamber to stabilize, turn the EUT on and measure the operating frequency after 2, 5, and 10 minutes.
- Repeat step c and d with every 10 degrees reduction until the lowest temperature achieved.
- The test chamber was allowed to stabilize at +20 degree C for a minimum of 30 minutes. The supply voltage was then adjusted on the EUT from 85% to 115% and the frequency record.

4.6.5 Deviation from Test Standard

No deviation.

4.6.6 EUT Operating Condition

Set the EUT transmit at un-modulation mode to test frequency stability.

4.6.7 Test Results

Frequency Stability Versus Temp.									
Operating Frequency: 5150MHz									
Temp. (°C)	Power Supply (Vac)	0 Minute		2 Minute		5 Minute		10 Minute	
		Measured Frequency (MHz)	Result	Measured Frequency (MHz)	Result	Measured Frequency (MHz)	Result	Measured Frequency (MHz)	Result
40	120	5180.019	Pass	5180.0186	Pass	5180.0157	Pass	5180.0141	Pass
30	120	5180.0143	Pass	5180.0156	Pass	5180.0178	Pass	5180.0186	Pass
20	120	5179.9908	Pass	5179.9874	Pass	5179.9905	Pass	5179.9877	Pass
10	120	5179.9909	Pass	5179.9921	Pass	5179.9954	Pass	5179.993	Pass
0	120	5179.9791	Pass	5179.9817	Pass	5179.9781	Pass	5179.9803	Pass

Frequency Stability Versus Voltage									
Operating Frequency: 5150MHz									
Temp. (°C)	Power Supply (Vac)	0 Minute		2 Minute		5 Minute		10 Minute	
		Measured Frequency (MHz)	Result	Measured Frequency (MHz)	Result	Measured Frequency (MHz)	Result	Measured Frequency (MHz)	Result
20	138	5179.99	Pass	5179.9918	Pass	5179.9958	Pass	5179.9929	Pass
	120	5179.9909	Pass	5179.9921	Pass	5179.9954	Pass	5179.993	Pass
	102	5179.9907	Pass	5179.9931	Pass	5179.9963	Pass	5179.994	Pass

4.7 6dB Bandwidth Measurement

4.7.1 Limits of 6dB Bandwidth Measurement

The minimum of 6dB Bandwidth Measurement is 0.5MHz.

4.7.2 Test Setup

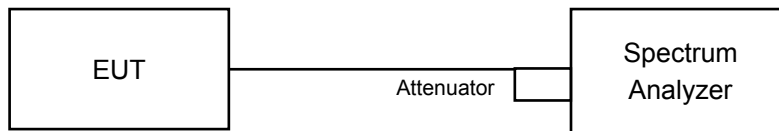

4.7.3 Test Instruments

Refer to section 4.1.2 to get information of above instrument.

4.7.4 Test Procedure

Measurement Procedure REF

- Set resolution bandwidth (RBW) = 100kHz
- Set the video bandwidth (VBW) $\geq 3 \times$ RBW, Detector = Peak.
- Trace mode = max hold.
- Sweep = auto couple.
- Measure the maximum width of the emission that is constrained by the frequencies associated with the two amplitude points (upper and lower) that are attenuated by 6 dB relative to the maximum level measured in the fundamental emission

4.7.5 Deviation from Test Standard

No deviation.

4.7.6 EUT Operating Condition

The software provided by client to enable the EUT under transmission condition continuously at lowest, middle and highest channel frequencies individually.

4.7.7 Test Results

802.11a

Channel	Frequency (MHz)	6dB Bandwidth (MHz)				Minimum Limit (MHz)	Pass / Fail
		Chain 0	Chain 1	Chain 2	Chain 3		
149	5745	16.40	16.39	16.36	16.39	0.5	Pass
157	5785	16.39	16.40	16.38	16.40	0.5	Pass
165	5825	16.38	16.40	16.38	16.37	0.5	Pass

802.11n (HT20)

Channel	Frequency (MHz)	6dB Bandwidth (MHz)				Minimum Limit (MHz)	Pass / Fail
		Chain 0	Chain 1	Chain 2	Chain 3		
149	5745	17.61	17.62	16.59	17.58	0.5	Pass
157	5785	17.23	17.62	17.60	17.58	0.5	Pass
165	5825	16.96	17.62	17.58	17.60	0.5	Pass

802.11n (HT40)

Channel	Frequency (MHz)	6dB Bandwidth (MHz)				Minimum Limit (MHz)	Pass / Fail
		Chain 0	Chain 1	Chain 2	Chain 3		
151	5755	34.01	35.21	35.11	35.18	0.5	Pass
159	5795	35.22	35.22	35.19	35.21	0.5	Pass

802.11ac (VHT80)

Channel	Frequency (MHz)	6dB Bandwidth (MHz)				Minimum Limit (MHz)	Pass / Fail
		Chain 0	Chain 1	Chain 2	Chain 3		
155	5775	76.46	76.53	76.40	76.38	0.5	Pass

802.11ac (VHT80+VHT80)

Channel	Frequency (MHz)	6dB Bandwidth (MHz)				Minimum Limit (MHz)	Pass / Fail
		Chain 0	Chain 1	Chain 2	Chain 3		
155	5775	-	-	75.97	75.94	0.5	Pass

Spectrum Plot of Worst Value

802.11a

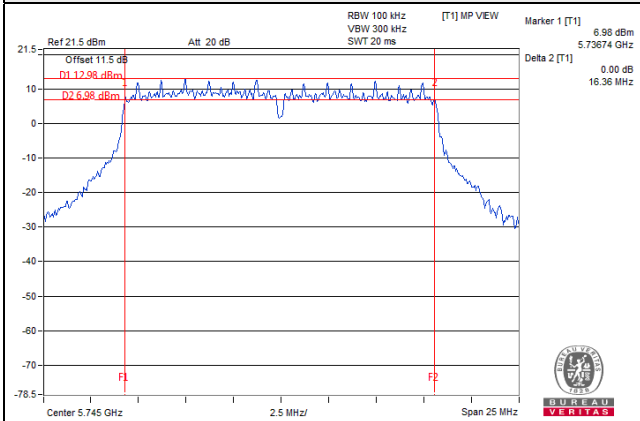

802.11n (HT20)

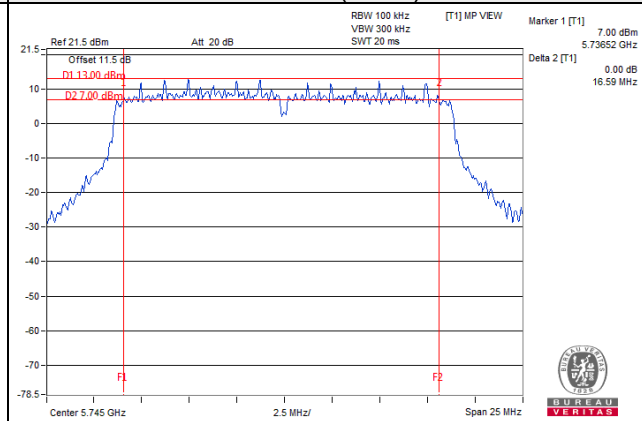

802.11n (HT40)

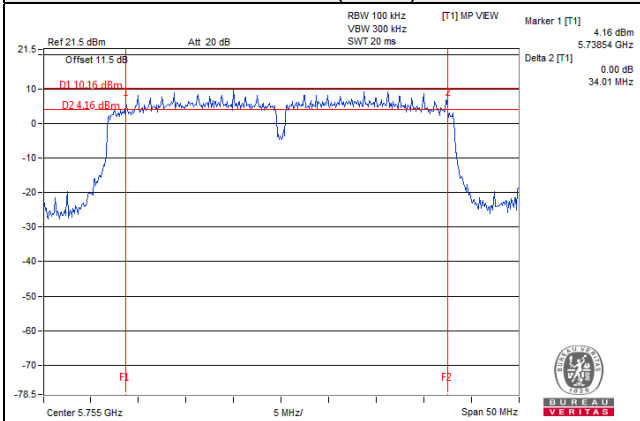

802.11ac (VHT80)

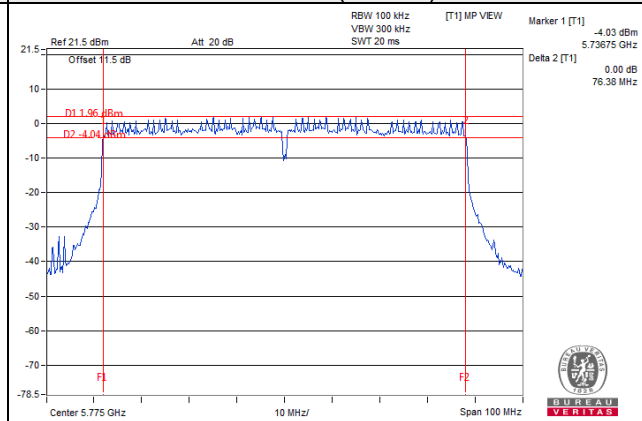

802.11ac (VHT80+VHT80)

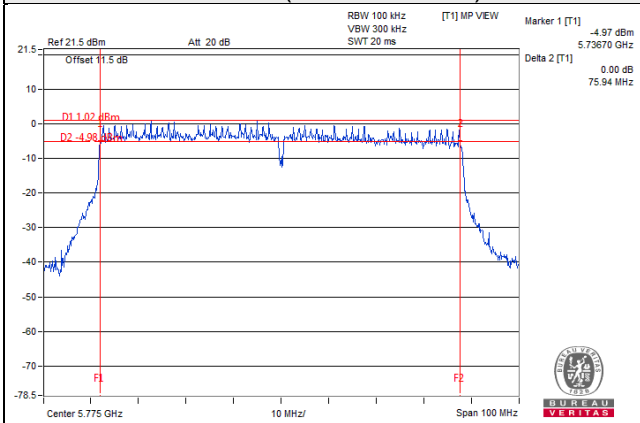

5 Pictures of Test Arrangements

Please refer to the attached file (Test Setup Photo).

Annex A- Radiated Out of Band Emission (OOBE) Measurement (For U-NII-3 band)

802.11a

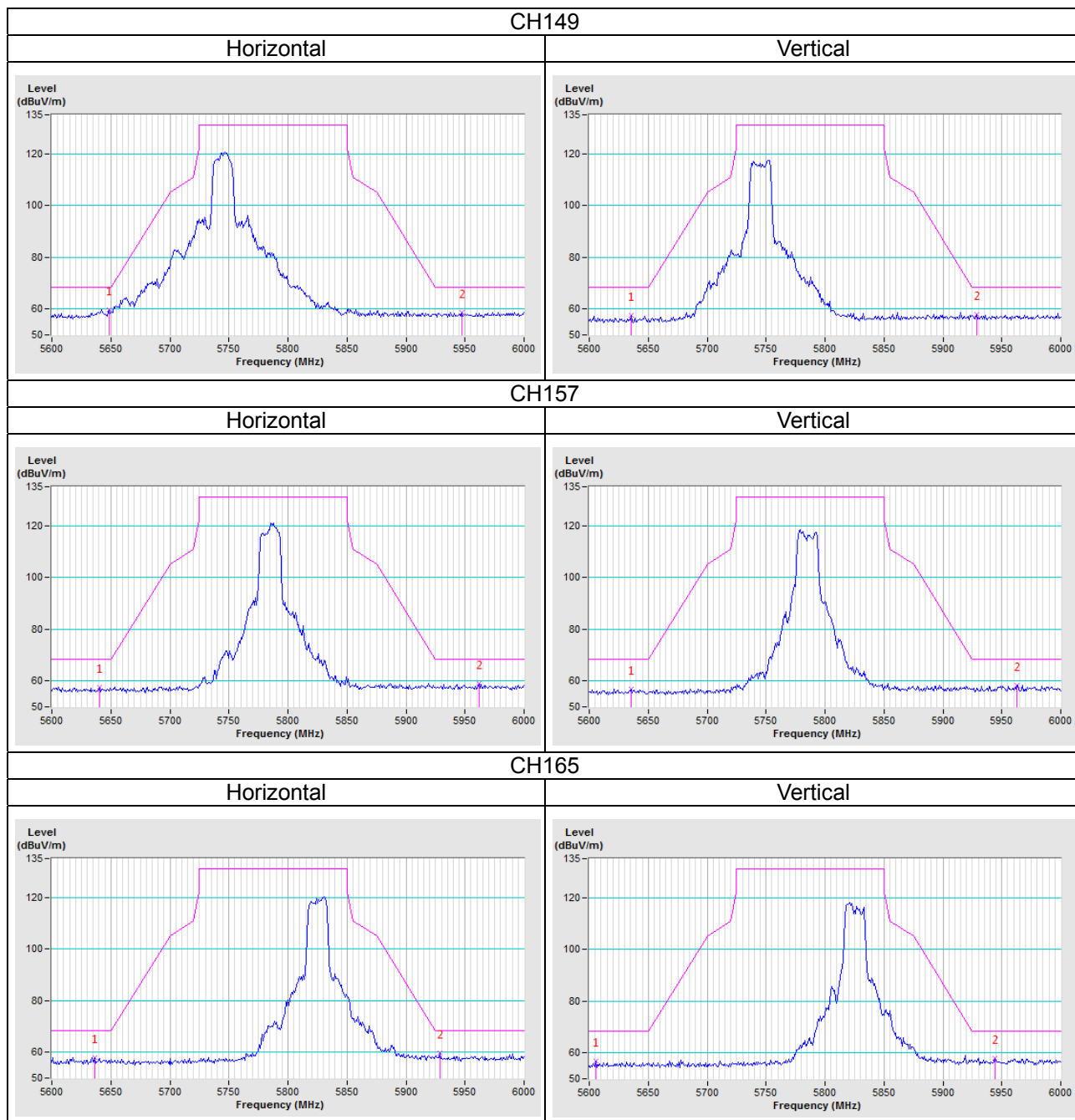

802.11n (HT20)

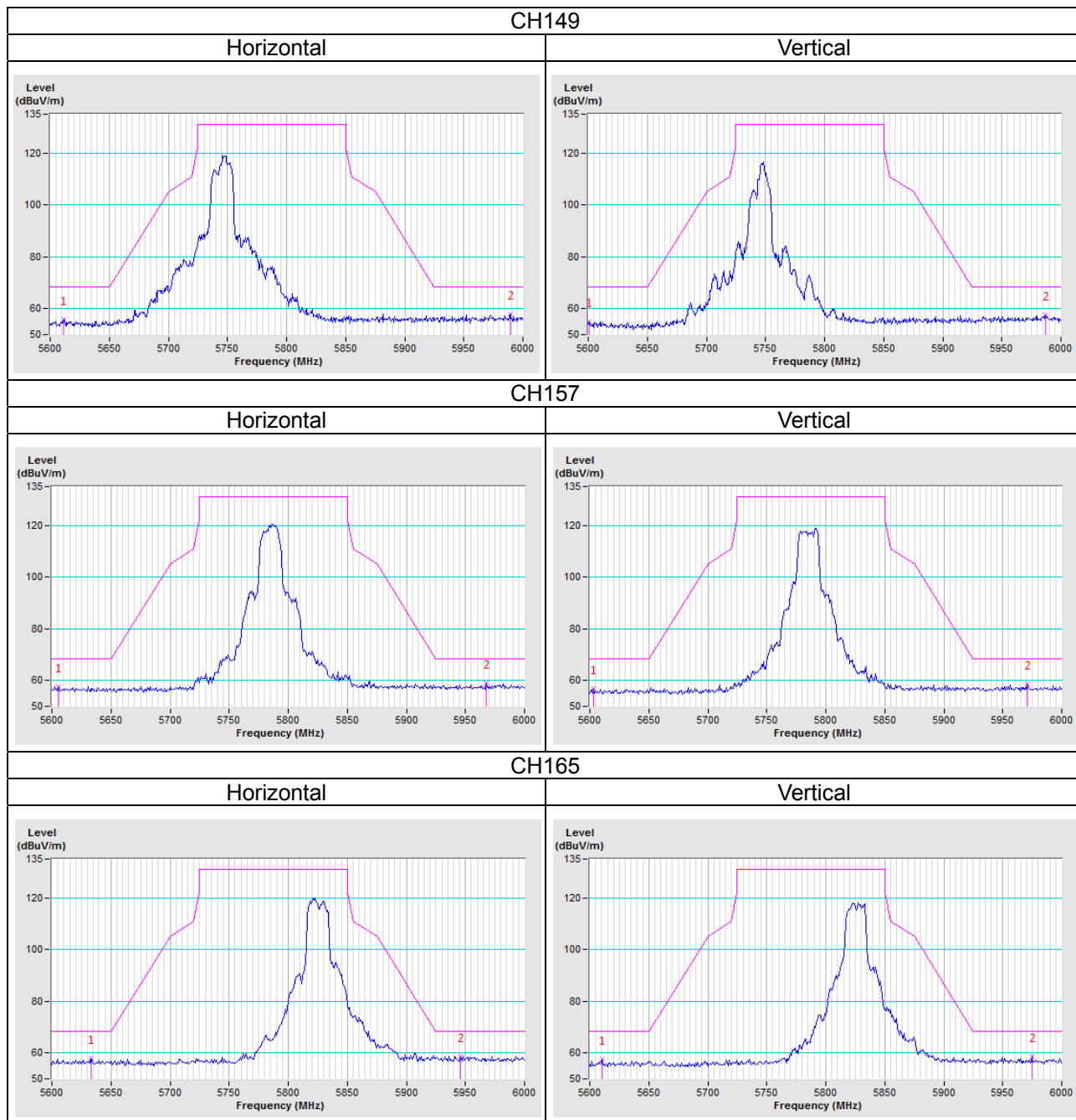

802.11n (HT40)

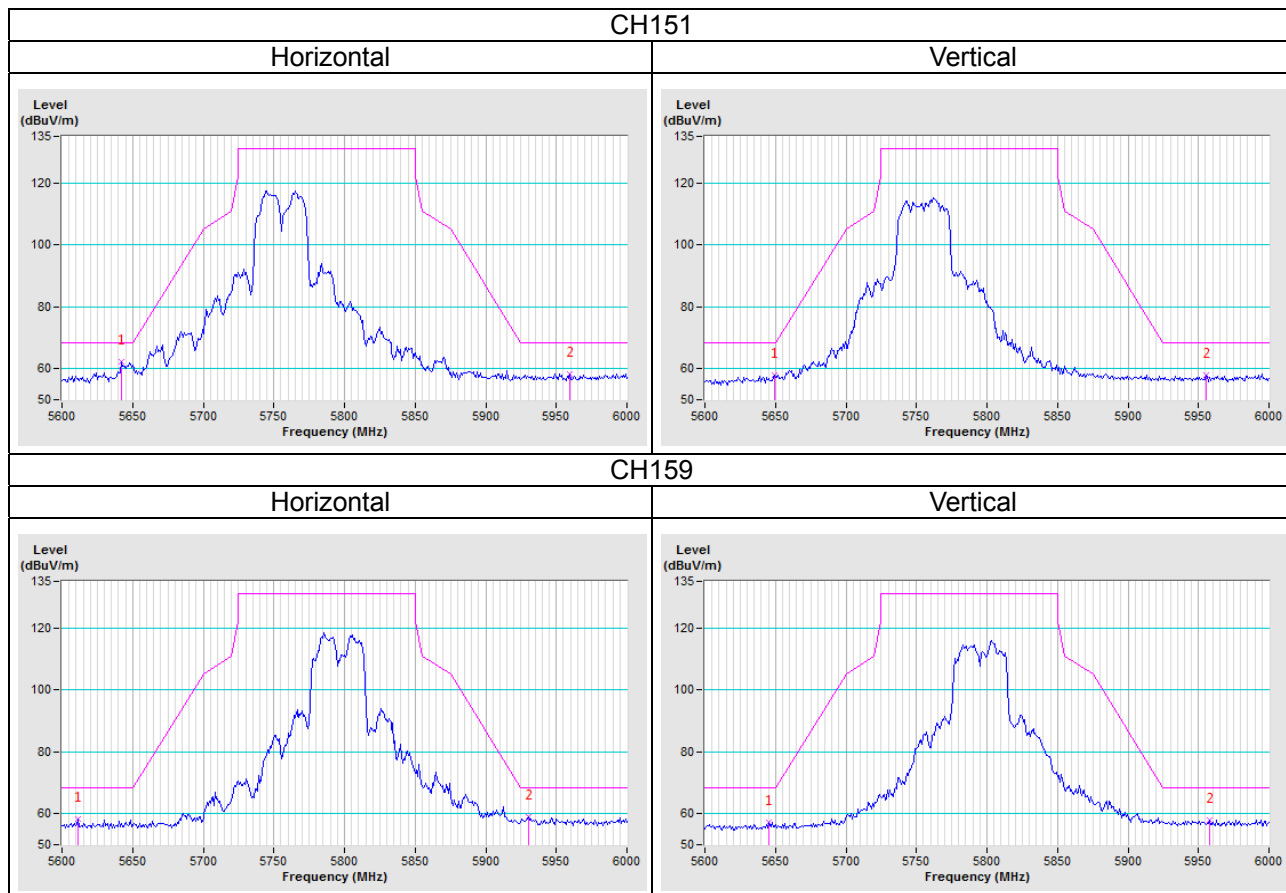

802.11ac (VHT80)

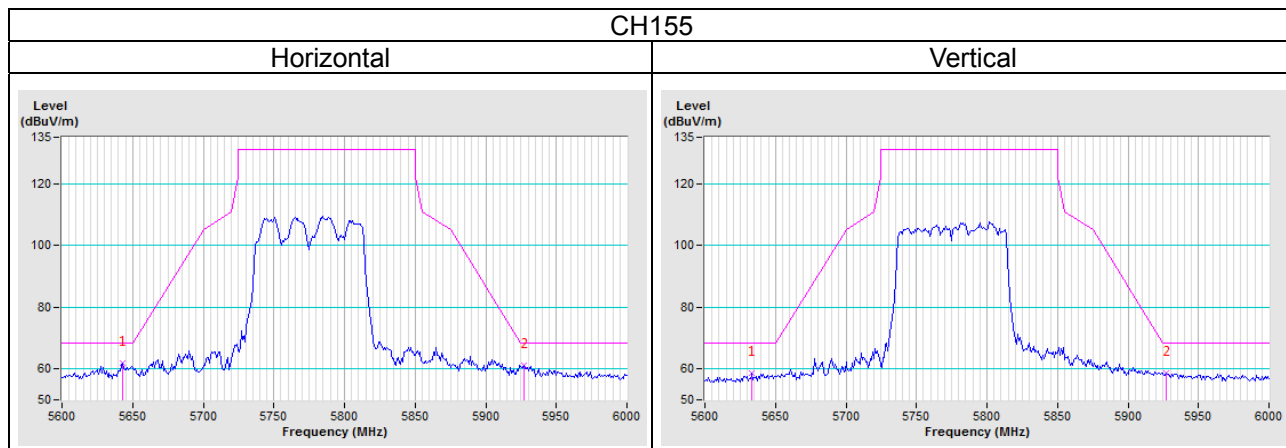

802.11ac (VHT80+VHT80)

CH155

Horizontal

Vertical

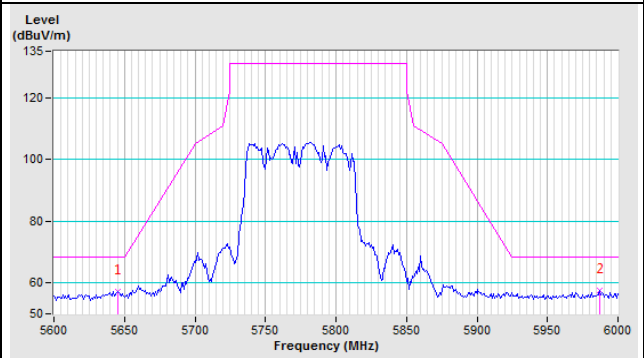
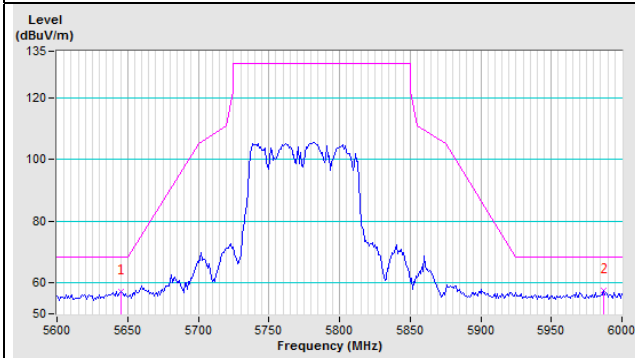

Appendix – Information of the Testing Laboratories

We, Bureau Veritas Consumer Products Services (H.K.) Ltd., Taoyuan Branch, were founded in 1988 to provide our best service in EMC, Radio, Telecom and Safety consultation. Our laboratories are FCC recognized accredited test firms and accredited and approved according to ISO/IEC 17025.

If you have any comments, please feel free to contact us at the following:

Lin Kou EMC/RF Lab

Tel: 886-2-26052180

Fax: 886-2-26051924

Hsin Chu EMC/RF/Telecom Lab

Tel: 886-3-6668565

Fax: 886-3-6668323

Hwa Ya EMC/RF/Safety

Tel: 886-3-3183232

Fax: 886-3-3270892

Email: service.adt@tw.bureauveritas.com

Web Site: www.bureauveritas-adt.com

The address and road map of all our labs can be found in our web site also.

--- END ---