



FCC TEST REPORT

REPORT NO.: RF120221C04 R1

MODEL NO.: DAP-2320

FCC ID: KA2AP2320A1

RECEIVED: Feb. 21, 2012

TESTED: Feb. 23 ~ Apr. 04, 2012

ISSUED: Apr. 11, 2012

APPLICANT: D-Link Corporation

ADDRESS: 17595 Mt. Herrmann, Fountain Valley, California
92708, United States

ISSUED BY: Bureau Veritas Consumer Products Services
(H.K.) Ltd., Taoyuan Branch

LAB ADDRESS: No. 47, 14th Ling, Chia Pau Vil., Lin Kou Dist.,
New Taipei City, Taiwan (R.O.C.)

TEST LOCATION: No. 19, Hwa Ya 2nd Rd, Wen Hwa Tsuen, Kwei
Shan Hsiang, Taoyuan Hsien 333, Taiwan, R.O.C.

This test report consists of 56 pages in total. It may be duplicated completely for legal use with the approval of the applicant. It should not be reproduced except in full, without the written approval of our laboratory. The client should not use it to claim product certification, approval or endorsement by TAF or any government agency. The test results in the report only apply to the tested sample.





TABLE OF CONTENTS

RELEASE CONTROL RECORD	4
1. CERTIFICATION.....	5
2. SUMMARY OF TEST RESULTS	6
2.1 MEASUREMENT UNCERTAINTY	6
3. GENERAL INFORMATION.....	7
3.1 GENERAL DESCRIPTION OF EUT.....	7
3.2 DESCRIPTION OF TEST MODES.....	8
3.2.1 TEST MODE APPLICABILITY AND TESTED CHANNEL DETAIL.....	9
3.3 DESCRIPTION OF SUPPORT UNITS	11
3.3.1 CONFIGURATION OF SYSTEM UNDER TEST	12
3.4 GENERAL DESCRIPTION OF APPLIED STANDARDS	13
4. TEST TYPES AND RESULTS	14
4.1 RADIATED EMISSION AND BANDEDGE MEASUREMENT	14
4.1.1 LIMITS OF RADIATED EMISSION AND BANDEDGE MEASUREMENT.....	14
4.1.2 TEST INSTRUMENTS.....	15
4.1.3 TEST PROCEDURES	16
4.1.4 DEVIATION FROM TEST STANDARD	16
4.1.5 TEST SETUP.....	17
4.1.6 EUT OPERATING CONDITIONS	17
4.1.7 TEST RESULTS	18
4.2 CONDUCTED EMISSION MEASUREMENT	33
4.2.1 LIMITS OF CONDUCTED EMISSION MEASUREMENT	33
4.2.2 TEST INSTRUMENTS.....	33
4.2.3 TEST PROCEDURES	34
4.2.4 DEVIATION FROM TEST STANDARD	34
4.2.5 TEST SETUP.....	34
4.2.6 EUT OPERATING CONDITIONS	34
4.2.7 TEST RESULTS	35
4.3 6dB BANDWIDTH MEASUREMENT	41
4.3.1 LIMITS OF 6dB BANDWIDTH MEASUREMENT.....	41
4.3.2 TEST SETUP.....	41
4.3.3 TEST INSTRUMENTS.....	41
4.3.4 TEST PROCEDURE.....	41
4.3.5 DEVIATION FROM TEST STANDARD	41
4.3.6 EUT OPERATING CONDITIONS	41
4.3.7 TEST RESULTS	42
4.4 CONDUCTED OUTPUT POWER	43
4.4.1 LIMITS OF CONDUCTED OUTPUT POWER MEASUREMENT	43
4.4.2 TEST SETUP.....	43
4.4.3 TEST INSTRUMENTS.....	43



A D T

4.4.4	TEST PROCEDURES	43
4.4.5	DEVIATION FROM TEST STANDARD	43
4.4.6	EUT OPERATING CONDITIONS	43
4.4.7	TEST RESULTS	44
4.5	POWER SPECTRAL DENSITY MEASUREMENT.....	45
4.5.1	LIMITS OF POWER SPECTRAL DENSITY MEASUREMENT	45
4.5.2	TEST SETUP.....	45
4.5.3	TEST INSTRUMENTS.....	45
4.5.4	TEST PROCEDURE.....	45
4.5.5	DEVIATION FROM TEST STANDARD	45
4.5.6	EUT OPERATING CONDITION	45
4.5.7	TEST RESULTS	46
4.6	CONDUCTED OUT OF BAND EMISSION MEASUREMENT	48
4.6.1	LIMITS OF CONDUCTED OUT OF BAND EMISSION MEASUREMENT.....	48
4.6.2	TEST SETUP.....	48
4.6.3	TEST INSTRUMENTS.....	48
4.6.4	TEST PROCEDURE.....	48
4.6.5	DEVIATION FROM TEST STANDARD	49
4.6.6	EUT OPERATING CONDITION	49
4.6.7	TEST RESULTS	49
5.	PHOTOGRAPHS OF THE TEST CONFIGURATION	54
6.	INFORMATION ON THE TESTING LABORATORIES.....	55
7.	APPENDIX A - MODIFICATIONS RECORDERS FOR ENGINEERING CHANGES TO THE EUT BY THE LAB	56



RELEASE CONTROL RECORD

ISSUE NO.	REASON FOR CHANGE	DATE ISSUED
RF120221C04	Original release	Mar. 05, 2012
RF120221C04 R1	Added second adapter (see page 8)	Apr. 11, 2012



1. CERTIFICATION

PRODUCT: 802.11N Ceiling Mount PoE Access Point
MODEL NO.: DAP-2320
BRAND: D-Link
APPLICANT: D-Link Corporation
TESTED: Feb. 23 ~ Apr. 04, 2012
TEST SAMPLE: ENGINEERING SAMPLE
STANDARDS: **FCC Part 15, Subpart C (Section 15.247)**
ANSI C63.10-2009

The above equipment (model: DAP-2320) has been tested by **Bureau Veritas Consumer Products Services (H.K.) Ltd., Taoyuan Branch**, and found compliance with the requirement of the above standards. The test record, data evaluation & Equipment Under Test (EUT) configurations represented herein are true and accurate accounts of the measurements of the sample's EMC characteristics under the conditions specified in this report.

PREPARED BY : Evelyn Wu , **DATE :** Apr. 11, 2012
Evelyn Wu / Specialist

APPROVED BY : Gary Chang , **DATE :** Apr. 11, 2012
Gary Chang / Technical Manager

2. SUMMARY OF TEST RESULTS

The EUT has been tested according to the following specifications:

APPLIED STANDARD: FCC PART 15, SUBPART C (SECTION 15.247)			
STANDARD SECTION	TEST TYPE	RESULT	REMARK
15.207	AC Power Conducted Emission	PASS	Meet the requirement of limit. Minimum passing margin is -6.80 dB at 29.85541MHz.
15.247(d) 15.209	Radiated Emissions	PASS	Meet the requirement of limit. Minimum passing margin is -1.1dB at 2390.00MHz.
15.247(d)	Band Edge Measurement	PASS	Meet the requirement of limit.
15.247(a)(2)	6dB bandwidth	PASS	Meet the requirement of limit.
15.247(b)	Conducted power	PASS	Meet the requirement of limit.
15.247(e)	Power Spectral Density	PASS	Meet the requirement of limit.
15.203	Antenna Requirement	PASS	No antenna connector is used.

2.1 MEASUREMENT UNCERTAINTY

Where relevant, the following measurement uncertainty levels have been estimated for tests performed on the EUT as specified in CISPR 16-4-2:

MEASUREMENT	FREQUENCY	UNCERTAINTY
Conducted emissions	150kHz~30MHz	2.44dB
Radiated emissions	30MHz ~ 200MHz	2.93dB
	200MHz ~1000MHz	2.95dB
	1GHz ~ 18GHz	2.26dB
	18GHz ~ 40GHz	1.94dB

This uncertainty represents an expanded uncertainty expressed at approximately the 95% confidence level using a coverage factor of $k = 2$.

3. GENERAL INFORMATION

3.1 GENERAL DESCRIPTION OF EUT

EUT	802.11N Ceiling Mount PoE Access Point
MODEL NO.	DAP-2320
POWER SUPPLY	5Vdc (Adapter) 48Vdc (POE)
MODULATION TYPE	CCK, DQPSK, DBPSK for DSSS 64QAM, 16QAM, QPSK, BPSK for OFDM
MODULATION TECHNOLOGY	DSSS, OFDM
TRANSFER RATE	802.11b:11.0/ 5.5/ 2.0/ 1.0Mbps 802.11g: 54.0/ 48.0/ 36.0/ 24.0/ 18.0/ 12.0/ 9.0/ 6.0Mbps 802.11n: up to 300.0Mbps
OPERATING FREQUENCY	2412 ~ 2462MHz
NUMBER OF CHANNEL	11 for 802.11b, 802.11g, 802.11n (20MHz) 7 for 802.11n (40MHz)
OUTPUT POWER	841.6mW
ANTENNA TYPE	PIFA antenna with 2dBi gain
ANTENNA CONNECTOR	N/A
DATA CABLE	N/A
I/O PORTS	RJ45
ACCESSORY DEVICES	Adapter

NOTE:

- The EUT incorporates a MIMO function. Physically, the EUT provides two completed transmitters and two receivers.

MODULATION MODE	TX FUNCTION
802.11b	2TX
802.11g	2TX
802.11n (20MHz)	2TX
802.11n (40MHz)	2TX

- The EUT uses following adapter & POE.

ADAPTER 1	
BRAND:	D-Link
MODEL:	CF1505-B
INPUT:	100-240Vac, 50/60Hz, 0.4A
OUTPUT:	5Vdc, 2.5A
POWER LINE:	1.5m non-shielded cable without core

ADAPTER 2	
BRAND:	D-Link
MODEL:	CF1505-B IW
INPUT:	100-240Vac, 50/60Hz, 0.4A
OUTPUT:	5Vdc, 2.5A
POWER LINE:	1.5m non-shielded cable without core

POE	
BRAND:	D-Link
MODEL:	DES-1210-08P
POE'S ADAPTER	
BRAND:	L.T.E
MODEL:	LTE90E-S5-1
INPUT:	100-240Vac, 47-63Hz, 1.4A
OUTPUT:	48Vdc, 1.875A MAX: 90W
POWER LINE:	1.3m non-shielded cable without core

*The POE and POE's adapter are for support units only.

- The above EUT information is declared by manufacturer and for more detailed features description, please refer to the manufacturer's specifications or user's manual.

3.2 DESCRIPTION OF TEST MODES

11 channels are provided for 802.11b, 802.11g and 802.11n (20MHz):

CHANNEL	FREQUENCY	CHANNEL	FREQUENCY
1	2412MHz	7	2442MHz
2	2417MHz	8	2447MHz
3	2422MHz	9	2452MHz
4	2427MHz	10	2457MHz
5	2432MHz	11	2462MHz
6	2437MHz		

7 channels are provided for 802.11n (40MHz):

CHANNEL	FREQUENCY	CHANNEL	FREQUENCY
1	2422MHz	5	2442MHz
2	2427MHz	6	2447MHz
3	2432MHz	7	2452MHz
4	2437MHz		



3.2.1 TEST MODE APPLICABILITY AND TESTED CHANNEL DETAIL

EUT CONFIGURE MODE	APPLICABLE TO				DESCRIPTION
	RE≥1G	RE<1G	PLC	APCM	
A	√	√	√	√	Power from AC Adapter 1
B	-	√	√	-	Power from POE
C	-	√	√	-	Power from AC Adapter 2

Where **RE≥1G**: Radiated Emission above 1GHz **RE<1G**: Radiated Emission below 1GHz
PLC: Power Line Conducted Emission **APCM**: Antenna Port Conducted Measurement

NOTE: "-" means no effect.

RADIATED EMISSION TEST (ABOVE 1GHz):

- Pre-Scan has been conducted to determine the worst-case mode from all possible combinations between available modulations, data rates and antenna ports (if EUT with antenna diversity architecture).
- Following channel(s) was (were) selected for the final test as listed below.

EUT CONFIGURE MODE	MODE	AVAILABLE CHANNEL	TESTED CHANNEL	MODULATION TECHNOLOGY	MODULATION TYPE	DATA RATE (Mbps)
A	802.11b	1 to 11	1, 6, 11	DSSS	DBPSK	1.0
A	802.11g	1 to 11	1, 6, 11	OFDM	BPSK	6.0
A	802.11n (20MHz)	1 to 11	1, 6, 11	OFDM	BPSK	7.2
A	802.11n (40MHz)	1 to 7	1, 4, 7	OFDM	BPSK	15.0

RADIATED EMISSION TEST (BELOW 1GHz):

- Pre-Scan has been conducted to determine the worst-case mode from all possible combinations between available modulations, data rates and antenna ports (if EUT with antenna diversity architecture).
- Following channel(s) was (were) selected for the final test as listed below.

EUT CONFIGURE MODE	MODE	AVAILABLE CHANNEL	TESTED CHANNEL	MODULATION TECHNOLOGY	MODULATION TYPE	DATA RATE (Mbps)
A, B, C	802.11n (20MHz)	1 to 11	6	OFDM	BPSK	7.2



POWER LINE CONDUCTED EMISSION TEST:

- Pre-Scan has been conducted to determine the worst-case mode from all possible combinations between available modulations, data rates and antenna ports (if EUT with antenna diversity architecture).
- Following channel(s) was (were) selected for the final test as listed below.

EUT CONFIGURE MODE	MODE	AVAILABLE CHANNEL	TESTED CHANNEL	MODULATION TECHNOLOGY	MODULATION TYPE	DATA RATE (Mbps)
A, B, C	802.11n (20MHz)	1 to 11	6	OFDM	BPSK	7.2

BANDEDGE MEASUREMENT:

- Pre-Scan has been conducted to determine the worst-case mode from all possible combinations between available modulations, data rates and antenna ports (if EUT with antenna diversity architecture).
- Following channel(s) was (were) selected for the final test as listed below.

EUT CONFIGURE MODE	MODE	AVAILABLE CHANNEL	TESTED CHANNEL	MODULATION TECHNOLOGY	MODULATION TYPE	DATA RATE (Mbps)
A	802.11b	1 to 11	1, 11	DSSS	DBPSK	1.0
A	802.11g	1 to 11	1, 11	OFDM	BPSK	6.0
A	802.11n (20MHz)	1 to 11	1, 11	OFDM	BPSK	7.2
A	802.11n (40MHz)	1 to 7	1, 7	OFDM	BPSK	15.0

ANTENNA PORT CONDUCTED MEASUREMENT:

- This item includes all test value of each mode, but only includes spectrum plot of worst value of each mode.
- Pre-Scan has been conducted to determine the worst-case mode from all possible combinations between available modulations, data rates and antenna ports (if EUT with antenna diversity architecture).
- Following channel(s) was (were) selected for the final test as listed below.

EUT CONFIGURE MODE	MODE	AVAILABLE CHANNEL	TESTED CHANNEL	MODULATION TECHNOLOGY	MODULATION TYPE	DATA RATE (Mbps)
A	802.11b	1 to 11	1, 6, 11	DSSS	DBPSK	1.0
A	802.11g	1 to 11	1, 6, 11	OFDM	BPSK	6.0
A	802.11n (20MHz)	1 to 11	1, 6, 11	OFDM	BPSK	7.2
A	802.11n (40MHz)	1 to 7	1, 4, 7	OFDM	BPSK	15.0

TEST CONDITION:

APPLICABLE TO	TEST MODE	ENVIRONMENTAL CONDITIONS	INPUT POWER	TESTED BY
RE \geq 1G	A	25deg. C, 68%RH	120Vac, 60Hz	Anderson Hong Sun Lin
RE $<$ 1G	A	25deg. C, 68%RH	120Vac, 60Hz	Sun Lin
	B	25deg. C, 65%RH		Anderson Hong
	C	25deg. C, 65%RH		
PLC	A	25deg. C, 68%RH	120Vac, 60Hz	Sun Lin
	B			Anderson Hong
	C			
APCM	A	26deg. C, 65%RH	120Vac, 60Hz	Brad Wu

3.3 DESCRIPTION OF SUPPORT UNITS

The EUT has been tested as an independent unit together with other necessary accessories or support units. The following support units or accessories were used to form a representative test configuration during the tests.

NO.	PRODUCT	BRAND	MODEL NO.	SERIAL NO.	FCC ID
1	NOTEBOOK	DELL	D531	CN-0XM006-4864 3-81U-2973	QDS-BRCM1020
2	POE	D-Link	DES-1210-08P	NA	NA

NO.	SIGNAL CABLE DESCRIPTION OF THE ABOVE SUPPORT UNITS
1	10m RJ45 UTP cable
2	1.8m RJ45 UTP cable

NOTE:

1. All power cords of the above support units are non shielded (1.8m).
2. Item 1 acted as communication partner to transfer data.
3. Item 2 is provided by the client.

3.3.1 CONFIGURATION OF SYSTEM UNDER TEST

TEST MODE A, C

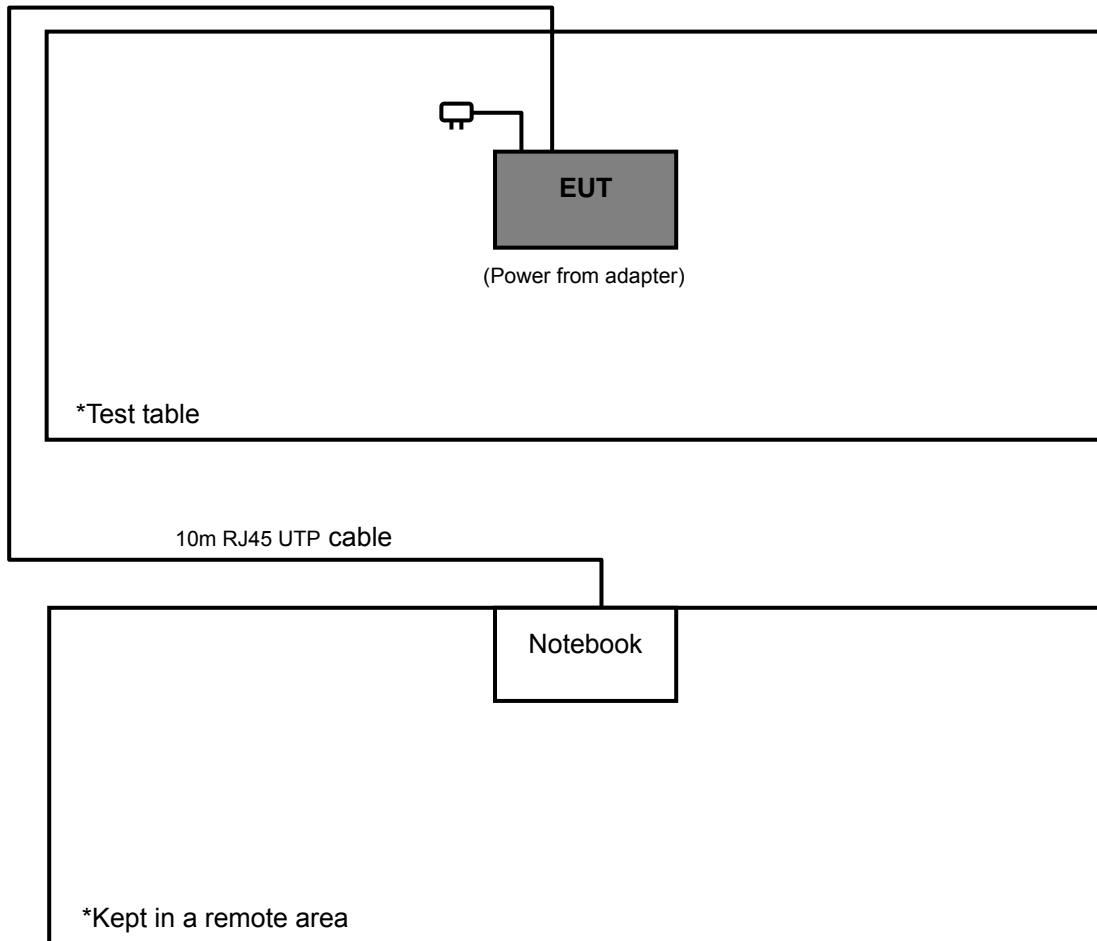

TEST MODE B

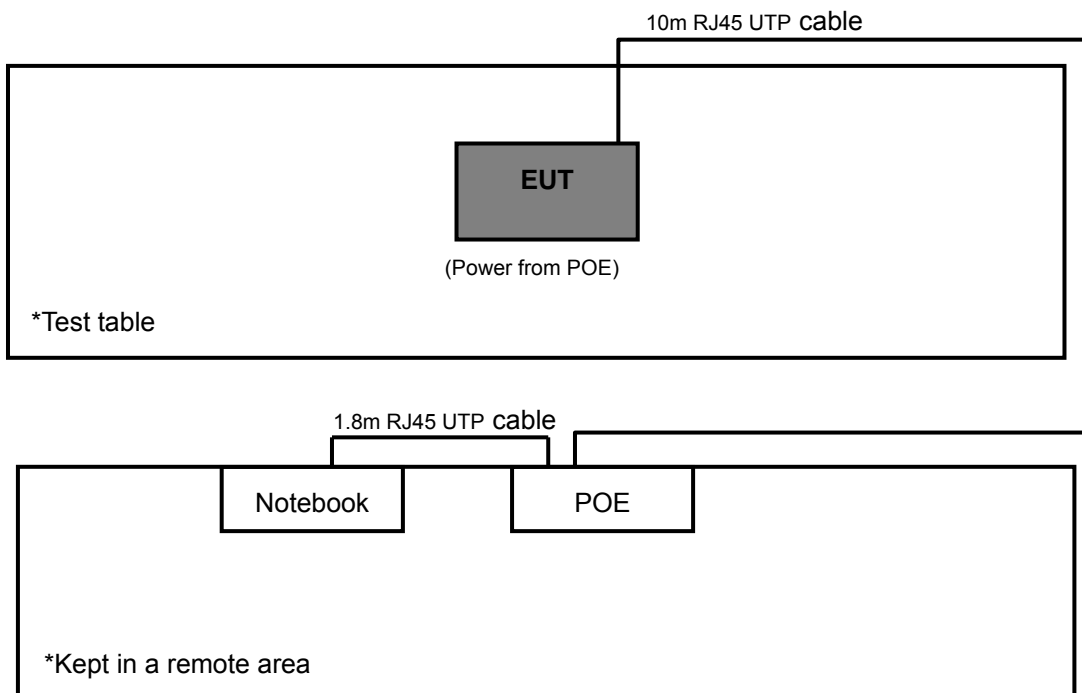

3.4 GENERAL DESCRIPTION OF APPLIED STANDARDS

The EUT is a RF Product. According to the specifications of the manufacturer, it must comply with the requirements of the following standards:

FCC Part 15, Subpart C (15.247)

ANSI C63.10-2009

All test items have been performed and recorded as per the above standards.

NOTE: The EUT is also considered as a kind of computer peripheral, because the connection to computer is necessary for typical use. It has been verified to comply with the requirements of FCC Part 15, Subpart B, Class B (DoC). The test report has been issued separately.

4. TEST TYPES AND RESULTS

4.1 RADIATED EMISSION AND BANDEDGE MEASUREMENT

4.1.1 LIMITS OF RADIATED EMISSION AND BANDEDGE MEASUREMENT

Radiated emissions which fall in the restricted bands must comply with the radiated emission limits specified as below table. Other emissions shall be at least 20dB below the highest level of the desired power:

FREQUENCIES (MHz)	FIELD STRENGTH (microvolts/meter)	MEASUREMENT DISTANCE (meters)
0.009 ~ 0.490	2400/F(kHz)	300
0.490 ~ 1.705	24000/F(kHz)	30
1.705 ~ 30.0	30	30
30 ~ 88	100	3
88 ~ 216	150	3
216 ~ 960	200	3
Above 960	500	3

NOTE:

1. The lower limit shall apply at the transition frequencies.
2. Emission level (dBuV/m) = 20 log Emission level (uV/m).
3. For frequencies above 1000MHz, the field strength limits are based on average detector, however, the peak field strength of any emission shall not exceed the maximum permitted average limits, specified above by more than 20dB under any condition of modulation.

4.1.2 TEST INSTRUMENTS

DESCRIPTION & MANUFACTURER	MODEL NO.	SERIAL NO.	DATE OF CALIBRATION	DUE DATE OF CALIBRATION
Test Receiver ROHDE & SCHWARZ	ESCI	100744	Apr. 19, 2011	Apr. 18, 2012
Spectrum Analyzer ROHDE & SCHWARZ	FSP40	100040	Aug. 04, 2011	Aug. 03, 2012
BILOG Antenna SCHWARZBECK	VULB9168	9168-156	Apr. 12, 2011	Apr. 11, 2012
HORN Antenna SCHWARZBECK	BBHA 9120 D	9120D-563	Sep. 06, 2011	Sep. 05, 2012
HORN Antenna SCHWARZBECK	BBHA 9170	148	Jul. 20, 2011	Jul. 19, 2012
Preamplifier Agilent	8449B	3008A01911	Oct. 29, 2011	Oct. 28, 2012
Preamplifier Agilent	8447D	2944A10638	Oct. 29, 2011	Oct. 28, 2012
RF signal cable HUBER+SUHNNER	SUCOFLEX 104	295013/4 283403/4	Aug. 19, 2011	Aug. 18, 2012
RF signal cable Worken	8D-FB	Cable-HYCH9-01	Aug. 13, 2011	Aug. 12, 2012
Software	ADT_Radiated_ V7.6.15.9.2	NA	NA	NA
Antenna Tower EMCO	2070/2080	512.835.4684	NA	NA
Turn Table EMCO	2087-2.03	NA	NA	NA
Antenna Tower & Turn Table Controller EMCO	2090	NA	NA	NA
High Speed Peak Power Meter	ML2495A	0842014	Apr. 26, 2011	Apr. 25, 2012
Power Sensor	MA2411B	0738404	Apr. 26, 2011	Apr. 25, 2012

- NOTE:**
1. The calibration interval of the above test instruments is 12 months and the calibrations are traceable to NML/ROC and NIST/USA.
 2. The test was performed in HwaYa Chamber 9.
 3. The horn antenna and HP preamplifier (model: 8449B) are used only for the measurement of emission frequency above 1GHz if tested.
 4. The FCC Site Registration No. is 460141.
 5. The IC Site Registration No. is IC 7450F-4.

4.1.3 TEST PROCEDURES

- a. The EUT was placed on the top of a rotating table 0.8 meters above the ground at a 3 meters semi-anechoic chamber. The table was rotated 360 degrees to determine the position of the highest radiation.
- b. The EUT was set 3 meters away from the interference-receiving antenna, which was mounted on the top of a variable-height antenna tower.
- c. Height of receiving antenna is varied from one meter to four meters above the ground to determine the maximum value of the field strength. Both horizontal and vertical polarizations of the antenna are set to make the measurement.
- d. For each suspected emission, the EUT was arranged to its worst case and then the antenna was tuned to heights from 1 meter to 4 meters and the rotatable table was turned from 0 degrees to 360 degrees to find the maximum reading.
- e. The test-receiver system was set to Peak Detect Function and Specified Bandwidth with Maximum Hold Mode.
- f. If the emission level of the EUT in peak mode was lower than the limit specified, then testing could be stopped and the peak values of the EUT would be reported. Otherwise the emissions would be re-tested one by one using peak, quasi-peak or average method as specified and then reported in a data sheet.

NOTE:

1. The resolution bandwidth and video bandwidth of test receiver/spectrum analyzer is 120kHz for Quasi-peak detection at frequency below 1GHz.
2. The resolution bandwidth of test receiver/spectrum analyzer is 1MHz and video bandwidth is 3MHz for Peak detection at frequency above 1GHz.
3. The resolution bandwidth of test receiver/spectrum analyzer is 1MHz and the video bandwidth is 10Hz for Average detection (AV) at frequency above 1GHz.
4. All modes of operation were investigated and the worst-case emissions are reported.

4.1.4 DEVIATION FROM TEST STANDARD

No deviation.

4.1.5 TEST SETUP

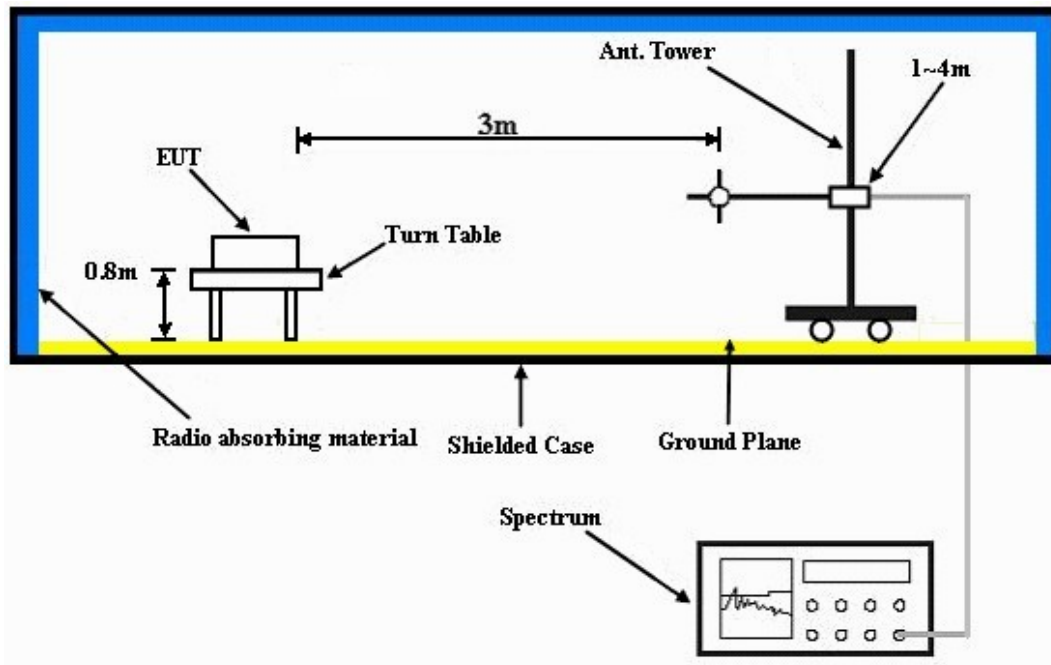

For the actual test configuration, please refer to the attached file (Test Setup Photo).

4.1.6 EUT OPERATING CONDITIONS

- Placed the EUT on the testing table.
- Prepared a notebook to act as communication partner and placed it outside of testing area.
- The communication partner connected with EUT via a RJ45 cable and run a test program (provided by manufacturer) to enable EUT under transmission condition continuously at specific channel frequency.
- The communication partner sent data to EUT by command "PING".



A D T

4.1.7 TEST RESULTS

Above 1GHz: 802.11b

EUT TEST CONDITION		MEASUREMENT DETAIL	
CHANNEL	Channel 1	FREQUENCY RANGE	1 ~ 25GHz
INPUT POWER	120Vac, 60 Hz	DETECTOR FUNCTION	Peak (PK) Average (AV)
ENVIRONMENTAL CONDITIONS	25deg. C, 68%RH	TESTED BY	Anderson Hong

ANTENNA POLARITY & TEST DISTANCE: HORIZONTAL AT 3 M								
NO.	FREQ. (MHz)	EMISSION LEVEL (dBuV/m)	LIMIT (dBuV/m)	MARGIN (dB)	ANTENNA HEIGHT (m)	TABLE ANGLE (Degree)	RAW VALUE (dBuV)	CORRECTION FACTOR (dB/m)
1	2375.00	63.6 PK	74.0	-10.4	1.36 H	301	32.20	31.40
2	2375.00	52.7 AV	54.0	-1.3	1.36 H	301	21.30	31.40
3	2390.00	69.7 PK	74.0	-4.3	1.30 H	308	38.30	31.40
4	2390.00	51.4 AV	54.0	-2.6	1.30 H	308	20.00	31.40
5	*2412.00	109.4 PK			1.30 H	312	77.90	31.50
6	*2412.00	105.4 AV			1.30 H	312	73.90	31.50
7	4824.00	49.6 PK	74.0	-24.4	1.01 H	228	12.10	37.50
8	4824.00	44.1 AV	54.0	-9.9	1.01 H	228	6.60	37.50
ANTENNA POLARITY & TEST DISTANCE: VERTICAL AT 3 M								
NO.	FREQ. (MHz)	EMISSION LEVEL (dBuV/m)	LIMIT (dBuV/m)	MARGIN (dB)	ANTENNA HEIGHT (m)	TABLE ANGLE (Degree)	RAW VALUE (dBuV)	CORRECTION FACTOR (dB/m)
1	2375.00	60.3 PK	74.0	-13.7	1.83 V	52	28.90	31.40
2	2375.00	49.3 AV	54.0	-4.7	1.83 V	52	17.90	31.40
3	2390.00	66.1 PK	74.0	-7.9	2.11 V	44	34.70	31.40
4	2390.00	48.1 AV	54.0	-5.9	2.11 V	44	16.70	31.40
5	*2412.00	105.6 PK			1.33 V	219	74.10	31.50
6	*2412.00	101.4 AV			1.33 V	219	69.90	31.50
7	4824.00	50.7 PK	74.0	-23.3	1.42 V	14	13.20	37.50
8	4824.00	46.4 AV	54.0	-7.6	1.42 V	14	8.90	37.50

- REMARKS:**
1. Emission level (dBuV/m) = Raw Value (dBuV) + Correction Factor (dB/m).
 2. Correction Factor (dB/m) = Antenna Factor (dB/m) + Cable Factor (dB).
 3. The other emission levels were very low against the limit.
 4. Margin value = Emission level – Limit value.
 5. “ * “: Fundamental frequency.



A D T

EUT TEST CONDITION		MEASUREMENT DETAIL	
CHANNEL	Channel 6	FREQUENCY RANGE	1 ~ 25GHz
INPUT POWER	120Vac, 60 Hz	DETECTOR FUNCTION	Peak (PK) Average (AV)
ENVIRONMENTAL CONDITIONS	25deg. C, 68%RH	TESTED BY	Anderson Hong

ANTENNA POLARITY & TEST DISTANCE: HORIZONTAL AT 3 M

NO.	FREQ. (MHz)	EMISSION LEVEL (dBuV/m)	LIMIT (dBuV/m)	MARGIN (dB)	ANTENNA HEIGHT (m)	TABLE ANGLE (Degree)	RAW VALUE (dBuV)	CORRECTION FACTOR (dB/m)
1	2375.00	62.1 PK	74.0	-11.9	1.36 H	298	30.70	31.40
2	2375.00	52.7 AV	54.0	-1.3	1.36 H	298	21.30	31.40
3	2390.00	64.6 PK	74.0	-9.4	1.30 H	306	33.20	31.40
4	2390.00	52.9 AV	54.0	-1.1	1.30 H	306	21.50	31.40
5	*2437.00	109.8 PK			1.31 H	313	78.20	31.60
6	*2437.00	105.7 AV			1.31 H	313	74.10	31.60
7	4874.00	52.1 PK	74.0	-21.9	1.01 H	227	14.50	37.60
8	4874.00	48.1 AV	54.0	-5.9	1.01 H	227	10.50	37.60
9	12185.00	57.9 PK	74.0	-16.1	1.51 H	256	9.20	48.70
10	12185.00	48.5 AV	54.0	-5.5	1.51 H	256	-0.20	48.70

ANTENNA POLARITY & TEST DISTANCE: VERTICAL AT 3 M

NO.	FREQ. (MHz)	EMISSION LEVEL (dBuV/m)	LIMIT (dBuV/m)	MARGIN (dB)	ANTENNA HEIGHT (m)	TABLE ANGLE (Degree)	RAW VALUE (dBuV)	CORRECTION FACTOR (dB/m)
1	2375.00	61.0 PK	74.0	-13.0	1.96 V	47	29.60	31.40
2	2375.00	50.0 AV	54.0	-4.0	1.96 V	47	18.60	31.40
3	2390.00	58.9 PK	74.0	-15.1	2.12 V	42	27.50	31.40
4	2390.00	49.1 AV	54.0	-4.9	2.12 V	42	17.70	31.40
5	*2437.00	106.0 PK			1.34 V	217	74.40	31.60
6	*2437.00	101.7 AV			1.34 V	217	70.10	31.60
7	4874.00	53.0 PK	74.0	-21.0	1.70 V	8	15.40	37.60
8	4874.00	50.2 AV	54.0	-3.8	1.70 V	8	12.60	37.60
9	12185.00	57.5 PK	74.0	-16.5	1.59 V	112	8.80	48.70
10	12185.00	50.6 AV	54.0	-3.4	1.59 V	112	1.90	48.70

- REMARKS:**
1. Emission level (dBuV/m) = Raw Value (dBuV) + Correction Factor (dB/m).
 2. Correction Factor (dB/m) = Antenna Factor (dB/m) + Cable Factor (dB).
 3. The other emission levels were very low against the limit.
 4. Margin value = Emission level – Limit value.
 5. “ * “: Fundamental frequency.



A D T

EUT TEST CONDITION		MEASUREMENT DETAIL	
CHANNEL	Channel 11	FREQUENCY RANGE	1 ~ 25GHz
INPUT POWER	120Vac, 60 Hz	DETECTOR FUNCTION	Peak (PK) Average (AV)
ENVIRONMENTAL CONDITIONS	25deg. C, 68%RH	TESTED BY	Anderson Hong

ANTENNA POLARITY & TEST DISTANCE: HORIZONTAL AT 3 M

NO.	FREQ. (MHz)	EMISSION LEVEL (dBuV/m)	LIMIT (dBuV/m)	MARGIN (dB)	ANTENNA HEIGHT (m)	TABLE ANGLE (Degree)	RAW VALUE (dBuV)	CORRECTION FACTOR (dB/m)
1	2375.00	62.7 PK	74.0	-11.3	1.27 H	304	31.30	31.40
2	2375.00	52.8 AV	54.0	-1.2	1.27 H	304	21.40	31.40
3	*2462.00	110.1 PK			1.30 H	318	78.40	31.70
4	*2462.00	105.8 AV			1.30 H	318	74.10	31.70
5	2483.50	72.0 PK	74.0	-2.0	1.28 H	290	40.20	31.80
6	2483.50	51.6 AV	54.0	-2.4	1.28 H	290	19.80	31.80
7	4924.00	50.3 PK	74.0	-23.7	1.01 H	218	12.60	37.70
8	4924.00	45.7 AV	54.0	-8.3	1.01 H	218	8.00	37.70

ANTENNA POLARITY & TEST DISTANCE: VERTICAL AT 3 M

NO.	FREQ. (MHz)	EMISSION LEVEL (dBuV/m)	LIMIT (dBuV/m)	MARGIN (dB)	ANTENNA HEIGHT (m)	TABLE ANGLE (Degree)	RAW VALUE (dBuV)	CORRECTION FACTOR (dB/m)
1	2375.00	58.6 PK	74.0	-15.4	1.69 V	247	27.20	31.40
2	2375.00	48.8 AV	54.0	-5.2	1.69 V	247	17.40	31.40
3	*2462.00	106.2 PK			1.56 V	219	74.50	31.70
4	*2462.00	101.8 AV			1.56 V	219	70.10	31.70
5	2483.50	69.3 PK	74.0	-4.7	1.56 V	215	37.50	31.80
6	2483.50	48.1 AV	54.0	-5.9	1.56 V	215	16.30	31.80
7	4924.00	53.5 PK	74.0	-20.5	1.05 V	187	15.80	37.70
8	4924.00	50.7 AV	54.0	-3.3	1.05 V	187	13.00	37.70

- REMARKS:**
1. Emission level (dBuV/m) = Raw Value (dBuV) + Correction Factor (dB/m).
 2. Correction Factor (dB/m) = Antenna Factor (dB/m) + Cable Factor (dB).
 3. The other emission levels were very low against the limit.
 4. Margin value = Emission level – Limit value.
 5. “ * “: Fundamental frequency.



802.11g

EUT TEST CONDITION		MEASUREMENT DETAIL	
CHANNEL	Channel 1	FREQUENCY RANGE	1 ~ 25GHz
INPUT POWER	120Vac, 60 Hz	DETECTOR FUNCTION	Peak (PK) Average (AV)
ENVIRONMENTAL CONDITIONS	25deg. C, 68%R	TESTED BY	Anderson Hong

ANTENNA POLARITY & TEST DISTANCE: HORIZONTAL AT 3 M

NO.	FREQ. (MHz)	EMISSION LEVEL (dBuV/m)	LIMIT (dBuV/m)	MARGIN (dB)	ANTENNA HEIGHT (m)	TABLE ANGLE (Degree)	RAW VALUE (dBuV)	CORRECTION FACTOR (dB/m)
1	2375.00	61.1 PK	74.0	-12.9	1.36 H	282	29.70	31.40
2	2375.00	51.7 AV	54.0	-2.3	1.36 H	282	20.30	31.40
3	2390.00	68.4 PK	74.0	-5.6	1.29 H	307	37.00	31.40
4	2390.00	52.4 AV	54.0	-1.6	1.29 H	307	21.00	31.40
5	*2412.00	108.4 PK			1.29 H	307	76.90	31.50
6	*2412.00	95.4 AV			1.29 H	307	63.90	31.50
7	4824.00	44.8 PK	74.0	-29.2	1.00 H	83	7.30	37.50
8	4824.00	31.9 AV	54.0	-22.1	1.00 H	83	-5.60	37.50

ANTENNA POLARITY & TEST DISTANCE: VERTICAL AT 3 M

NO.	FREQ. (MHz)	EMISSION LEVEL (dBuV/m)	LIMIT (dBuV/m)	MARGIN (dB)	ANTENNA HEIGHT (m)	TABLE ANGLE (Degree)	RAW VALUE (dBuV)	CORRECTION FACTOR (dB/m)
1	2375.00	61.0 PK	74.0	-13.0	1.47 V	32	29.60	31.40
2	2375.00	49.9 AV	54.0	-4.1	1.47 V	32	18.50	31.40
3	2390.00	64.2 PK	74.0	-9.8	1.70 V	44	32.80	31.40
4	2390.00	49.2 AV	54.0	-4.8	1.70 V	44	17.80	31.40
5	*2412.00	105.2 PK			1.68 V	82	73.70	31.50
6	*2412.00	91.8 AV			1.68 V	82	60.30	31.50
7	4824.00	46.1 PK	74.0	-27.9	1.21 V	190	8.60	37.50
8	4824.00	33.2 AV	54.0	-20.8	1.21 V	190	-4.30	37.50

- REMARKS:**
1. Emission level (dBuV/m) = Raw Value (dBuV) + Correction Factor (dB/m).
 2. Correction Factor (dB/m) = Antenna Factor (dB/m) + Cable Factor (dB).
 3. The other emission levels were very low against the limit.
 4. Margin value = Emission level – Limit value.
 5. “ * “: Fundamental frequency.



A D T

EUT TEST CONDITION		MEASUREMENT DETAIL	
CHANNEL	Channel 6	FREQUENCY RANGE	1 ~ 25GHz
INPUT POWER	120Vac, 60 Hz	DETECTOR FUNCTION	Peak (PK) Average (AV)
ENVIRONMENTAL CONDITIONS	25deg. C, 68%RH	TESTED BY	Anderson Hong

ANTENNA POLARITY & TEST DISTANCE: HORIZONTAL AT 3 M

NO.	FREQ. (MHz)	EMISSION LEVEL (dBuV/m)	LIMIT (dBuV/m)	MARGIN (dB)	ANTENNA HEIGHT (m)	TABLE ANGLE (Degree)	RAW VALUE (dBuV)	CORRECTION FACTOR (dB/m)
1	2375.00	62.7 PK	74.0	-11.3	1.34 H	297	31.30	31.40
2	2375.00	52.7 AV	54.0	-1.3	1.34 H	297	21.30	31.40
3	*2437.00	109.7 PK			1.30 H	293	78.10	31.60
4	*2437.00	96.7 AV			1.30 H	293	65.10	31.60
5	4874.00	44.6 PK	74.0	-29.4	1.00 H	80	7.00	37.60
6	4874.00	32.0 AV	54.0	-22.0	1.00 H	80	-5.60	37.60

ANTENNA POLARITY & TEST DISTANCE: VERTICAL AT 3 M

NO.	FREQ. (MHz)	EMISSION LEVEL (dBuV/m)	LIMIT (dBuV/m)	MARGIN (dB)	ANTENNA HEIGHT (m)	TABLE ANGLE (Degree)	RAW VALUE (dBuV)	CORRECTION FACTOR (dB/m)
1	2375.00	58.1 PK	74.0	-15.9	1.40 V	219	26.70	31.40
2	2375.00	48.4 AV	54.0	-5.6	1.40 V	219	17.00	31.40
3	*2437.00	106.2 PK			1.65 V	57	74.60	31.60
4	*2437.00	92.7 AV			1.65 V	57	61.10	31.60
5	4874.00	48.4 PK	74.0	-25.6	1.20 V	191	10.80	37.60
6	4874.00	35.4 AV	54.0	-18.6	1.20 V	191	-2.20	37.60

- REMARKS:**
1. Emission level (dBuV/m) = Raw Value (dBuV) + Correction Factor (dB/m).
 2. Correction Factor (dB/m) = Antenna Factor (dB/m) + Cable Factor (dB).
 3. The other emission levels were very low against the limit.
 4. Margin value = Emission level – Limit value.
 5. “ * “: Fundamental frequency.



A D T

EUT TEST CONDITION		MEASUREMENT DETAIL	
CHANNEL	Channel 11	FREQUENCY RANGE	1 ~ 25GHz
INPUT POWER	120Vac, 60 Hz	DETECTOR FUNCTION	Peak (PK) Average (AV)
ENVIRONMENTAL CONDITIONS	25deg. C, 68%RH	TESTED BY	Anderson Hong

ANTENNA POLARITY & TEST DISTANCE: HORIZONTAL AT 3 M

NO.	FREQ. (MHz)	EMISSION LEVEL (dBuV/m)	LIMIT (dBuV/m)	MARGIN (dB)	ANTENNA HEIGHT (m)	TABLE ANGLE (Degree)	RAW VALUE (dBuV)	CORRECTION FACTOR (dB/m)
1	2375.00	63.2 PK	74.0	-10.8	1.33 H	305	31.80	31.40
2	2375.00	52.0 AV	54.0	-2.0	1.33 H	305	20.60	31.40
3	*2462.00	108.2 PK			1.28 H	316	76.50	31.70
4	*2462.00	94.9 AV			1.28 H	316	63.20	31.70
5	2483.50	69.4 PK	74.0	-4.6	1.26 H	291	37.60	31.80
6	2483.50	52.8 AV	54.0	-1.2	1.26 H	291	21.00	31.80
7	4924.00	45.1 PK	74.0	-28.9	1.02 H	85	7.40	37.70
8	4924.00	32.2 AV	54.0	-21.8	1.02 H	85	-5.50	37.70

ANTENNA POLARITY & TEST DISTANCE: VERTICAL AT 3 M

NO.	FREQ. (MHz)	EMISSION LEVEL (dBuV/m)	LIMIT (dBuV/m)	MARGIN (dB)	ANTENNA HEIGHT (m)	TABLE ANGLE (Degree)	RAW VALUE (dBuV)	CORRECTION FACTOR (dB/m)
1	2375.00	61.0 PK	74.0	-13.0	1.52 V	71	29.60	31.40
2	2375.00	50.3 AV	54.0	-3.7	1.52 V	71	18.90	31.40
3	*2462.00	105.1 PK			1.34 V	55	73.40	31.70
4	*2462.00	91.3 AV			1.34 V	55	59.60	31.70
5	2483.50	65.6 PK	74.0	-8.4	1.30 V	57	33.80	31.80
6	2483.50	49.3 AV	54.0	-4.7	1.30 V	57	17.50	31.80
7	4924.00	46.5 PK	74.0	-27.5	1.25 V	193	8.80	37.70
8	4924.00	33.6 AV	54.0	-20.4	1.25 V	193	-4.10	37.70

- REMARKS:**
1. Emission level (dBuV/m) = Raw Value (dBuV) + Correction Factor (dB/m).
 2. Correction Factor (dB/m) = Antenna Factor (dB/m) + Cable Factor (dB).
 3. The other emission levels were very low against the limit.
 4. Margin value = Emission level – Limit value.
 5. “ * “: Fundamental frequency.



A D T

802.11n (20MHz)

EUT TEST CONDITION		MEASUREMENT DETAIL	
CHANNEL	Channel 1	FREQUENCY RANGE	1 ~ 25GHz
INPUT POWER	120Vac, 60 Hz	DETECTOR FUNCTION	Peak (PK) Average (AV)
ENVIRONMENTAL CONDITIONS	25deg. C, 68%RH	TESTED BY	Anderson Hong

ANTENNA POLARITY & TEST DISTANCE: HORIZONTAL AT 3 M

NO.	FREQ. (MHz)	EMISSION LEVEL (dBuV/m)	LIMIT (dBuV/m)	MARGIN (dB)	ANTENNA HEIGHT (m)	TABLE ANGLE (Degree)	RAW VALUE (dBuV)	CORRECTION FACTOR (dB/m)
1	2375.00	61.1 PK	74.0	-12.9	1.36 H	298	29.70	31.40
2	2375.00	51.6 AV	54.0	-2.4	1.36 H	298	20.20	31.40
3	2390.00	68.1 PK	74.0	-5.9	1.35 H	295	36.70	31.40
4	2390.00	52.7 AV	54.0	-1.3	1.35 H	295	21.30	31.40
5	*2412.00	107.2 PK			1.35 H	293	75.70	31.50
6	*2412.00	94.0 AV			1.35 H	293	62.50	31.50
7	4824.00	45.4 PK	74.0	-28.6	1.35 H	178	7.90	37.50
8	4824.00	34.1 AV	54.0	-19.9	1.35 H	178	-3.40	37.50

ANTENNA POLARITY & TEST DISTANCE: VERTICAL AT 3 M

NO.	FREQ. (MHz)	EMISSION LEVEL (dBuV/m)	LIMIT (dBuV/m)	MARGIN (dB)	ANTENNA HEIGHT (m)	TABLE ANGLE (Degree)	RAW VALUE (dBuV)	CORRECTION FACTOR (dB/m)
1	2375.00	60.3 PK	74.0	-13.7	1.38 V	22	28.90	31.40
2	2375.00	49.2 AV	54.0	-4.8	1.38 V	22	17.80	31.40
3	2390.00	63.1 PK	74.0	-10.9	1.36 V	52	31.70	31.40
4	2390.00	49.5 AV	54.0	-4.5	1.36 V	52	18.10	31.40
5	*2412.00	104.0 PK			1.36 V	52	72.50	31.50
6	*2412.00	90.6 AV			1.36 V	52	59.10	31.50
7	4824.00	43.4 PK	74.0	-30.6	1.02 V	277	5.90	37.50
8	4824.00	33.9 AV	54.0	-20.1	1.02 V	277	-3.60	37.50

- REMARKS:**
1. Emission level (dBuV/m) = Raw Value (dBuV) + Correction Factor (dB/m).
 2. Correction Factor (dB/m) = Antenna Factor (dB/m) + Cable Factor (dB).
 3. The other emission levels were very low against the limit.
 4. Margin value = Emission level – Limit value.
 5. “ * “: Fundamental frequency.



A D T

EUT TEST CONDITION		MEASUREMENT DETAIL	
CHANNEL	Channel 6	FREQUENCY RANGE	1 ~ 25GHz
INPUT POWER	120Vac, 60 Hz	DETECTOR FUNCTION	Peak (PK) Average (AV)
ENVIRONMENTAL CONDITIONS	25deg. C, 68%RH	TESTED BY	Sun Lin

ANTENNA POLARITY & TEST DISTANCE: HORIZONTAL AT 3 M

NO.	FREQ. (MHz)	EMISSION LEVEL (dBuV/m)	LIMIT (dBuV/m)	MARGIN (dB)	ANTENNA HEIGHT (m)	TABLE ANGLE (Degree)	RAW VALUE (dBuV)	CORRECTION FACTOR (dB/m)
1	2375.00	62.8 PK	74.0	-11.2	1.35 H	296	31.40	31.40
2	2375.00	52.8 AV	54.0	-1.2	1.35 H	296	21.40	31.40
3	*2437.00	109.4 PK			1.34 H	291	77.80	31.60
4	*2437.00	96.3 AV			1.34 H	291	64.70	31.60
5	4874.00	45.9 PK	74.0	-28.1	1.35 H	325	8.30	37.60
6	4874.00	35.1 AV	54.0	-18.9	1.35 H	325	-2.50	37.60

ANTENNA POLARITY & TEST DISTANCE: VERTICAL AT 3 M

NO.	FREQ. (MHz)	EMISSION LEVEL (dBuV/m)	LIMIT (dBuV/m)	MARGIN (dB)	ANTENNA HEIGHT (m)	TABLE ANGLE (Degree)	RAW VALUE (dBuV)	CORRECTION FACTOR (dB/m)
1	2375.00	59.0 PK	74.0	-15.0	1.52 V	157	27.60	31.40
2	2375.00	48.4 AV	54.0	-5.6	1.52 V	157	17.00	31.40
3	*2437.00	106.0 PK			1.37 V	43	74.40	31.60
4	*2437.00	92.7 AV			1.37 V	43	61.10	31.60
5	4874.00	44.2 PK	74.0	-29.8	1.22 V	135	6.60	37.60
6	4874.00	32.6 AV	54.0	-21.4	1.22 V	135	-5.00	37.60

- REMARKS:**
1. Emission level (dBuV/m) = Raw Value (dBuV) + Correction Factor (dB/m).
 2. Correction Factor (dB/m) = Antenna Factor (dB/m) + Cable Factor (dB).
 3. The other emission levels were very low against the limit.
 4. Margin value = Emission level – Limit value.
 5. “ * “: Fundamental frequency.



A D T

EUT TEST CONDITION		MEASUREMENT DETAIL	
CHANNEL	Channel 11	FREQUENCY RANGE	1 ~ 25GHz
INPUT POWER	120Vac, 60 Hz	DETECTOR FUNCTION	Peak (PK) Average (AV)
ENVIRONMENTAL CONDITIONS	25deg. C, 68%RH	TESTED BY	Sun Lin

ANTENNA POLARITY & TEST DISTANCE: HORIZONTAL AT 3 M

NO.	FREQ. (MHz)	EMISSION LEVEL (dBuV/m)	LIMIT (dBuV/m)	MARGIN (dB)	ANTENNA HEIGHT (m)	TABLE ANGLE (Degree)	RAW VALUE (dBuV)	CORRECTION FACTOR (dB/m)
1	2375.00	63.7 PK	74.0	-10.3	1.36 H	297	32.30	31.40
2	2375.00	52.2 AV	54.0	-1.8	1.36 H	297	20.80	31.40
3	*2462.00	108.3 PK			1.29 H	287	76.60	31.70
4	*2462.00	96.9 AV			1.29 H	287	65.20	31.70
5	2483.50	71.2 PK	74.0	-2.8	1.29 H	287	39.40	31.80
6	2483.50	52.7 AV	54.0	-1.3	1.29 H	287	20.90	31.80
7	4924.00	46.2 PK	74.0	-27.8	1.34 H	224	8.50	37.70
8	4924.00	34.8 AV	54.0	-19.2	1.34 H	224	-2.90	37.70

ANTENNA POLARITY & TEST DISTANCE: VERTICAL AT 3 M

NO.	FREQ. (MHz)	EMISSION LEVEL (dBuV/m)	LIMIT (dBuV/m)	MARGIN (dB)	ANTENNA HEIGHT (m)	TABLE ANGLE (Degree)	RAW VALUE (dBuV)	CORRECTION FACTOR (dB/m)
1	2375.00	58.8 PK	74.0	-15.2	1.34 V	27	27.40	31.40
2	2375.00	48.3 AV	54.0	-5.7	1.34 V	27	16.90	31.40
3	*2462.00	105.0 PK			1.63 V	38	73.30	31.70
4	*2462.00	91.7 AV			1.63 V	38	60.00	31.70
5	2483.50	61.0 PK	74.0	-13.0	1.63 V	38	29.20	31.80
6	2483.50	47.5 AV	54.0	-6.5	1.63 V	38	15.70	31.80
7	4924.00	44.7 PK	74.0	-29.3	1.18 V	147	7.00	37.70
8	4924.00	32.8 AV	54.0	-21.2	1.18 V	147	-4.90	37.70

- REMARKS:**
1. Emission level (dBuV/m) = Raw Value (dBuV) + Correction Factor (dB/m).
 2. Correction Factor (dB/m) = Antenna Factor (dB/m) + Cable Factor (dB).
 3. The other emission levels were very low against the limit.
 4. Margin value = Emission level – Limit value.
 5. “ * “: Fundamental frequency.



A D T

802.11n (40MHz)

EUT TEST CONDITION		MEASUREMENT DETAIL	
CHANNEL	Channel 1	FREQUENCY RANGE	1 ~ 25GHz
INPUT POWER	120Vac, 60 Hz	DETECTOR FUNCTION	Peak (PK) Average (AV)
ENVIRONMENTAL CONDITIONS	25deg. C, 68%RH	TESTED BY	Sun Lin

ANTENNA POLARITY & TEST DISTANCE: HORIZONTAL AT 3 M

NO.	FREQ. (MHz)	EMISSION LEVEL (dBuV/m)	LIMIT (dBuV/m)	MARGIN (dB)	ANTENNA HEIGHT (m)	TABLE ANGLE (Degree)	RAW VALUE (dBuV)	CORRECTION FACTOR (dB/m)
1	2375.00	61.7 PK	74.0	-12.3	1.33 H	293	30.30	31.40
2	2375.00	51.0 AV	54.0	-3.0	1.33 H	293	19.60	31.40
3	2390.00	65.5 PK	74.0	-8.5	1.33 H	297	34.10	31.40
4	2390.00	52.6 AV	54.0	-1.4	1.33 H	297	21.20	31.40
5	*2422.00	100.9 PK			1.33 H	299	69.40	31.50
6	*2422.00	87.6 AV			1.33 H	299	56.10	31.50
7	4844.00	43.5 PK	74.0	-30.5	1.27 H	168	6.00	37.50
8	4844.00	33.5 AV	54.0	-20.5	1.27 H	168	-4.00	37.50

ANTENNA POLARITY & TEST DISTANCE: VERTICAL AT 3 M

NO.	FREQ. (MHz)	EMISSION LEVEL (dBuV/m)	LIMIT (dBuV/m)	MARGIN (dB)	ANTENNA HEIGHT (m)	TABLE ANGLE (Degree)	RAW VALUE (dBuV)	CORRECTION FACTOR (dB/m)
1	2375.00	60.3 PK	74.0	-13.7	1.24 V	59	28.90	31.40
2	2375.00	49.0 AV	54.0	-5.0	1.24 V	59	17.60	31.40
3	2390.00	63.2 PK	74.0	-10.8	1.28 V	34	31.80	31.40
4	2390.00	50.1 AV	54.0	-3.9	1.28 V	34	18.70	31.40
5	*2422.00	97.8 PK			1.28 V	41	66.30	31.50
6	*2422.00	84.3 AV			1.28 V	41	52.80	31.50
7	4844.00	41.7 PK	74.0	-32.3	1.34 V	292	4.20	37.50
8	4844.00	32.0 AV	54.0	-22.0	1.34 V	292	-5.50	37.50

- REMARKS:**
1. Emission level (dBuV/m) = Raw Value (dBuV) + Correction Factor (dB/m).
 2. Correction Factor (dB/m) = Antenna Factor (dB/m) + Cable Factor (dB).
 3. The other emission levels were very low against the limit.
 4. Margin value = Emission level – Limit value.
 5. “ * “: Fundamental frequency.



A D T

EUT TEST CONDITION		MEASUREMENT DETAIL	
CHANNEL	Channel 4	FREQUENCY RANGE	1 ~ 25GHz
INPUT POWER	120Vac, 60 Hz	DETECTOR FUNCTION	Peak (PK) Average (AV)
ENVIRONMENTAL CONDITIONS	25deg. C, 68%RH	TESTED BY	Sun Lin

ANTENNA POLARITY & TEST DISTANCE: HORIZONTAL AT 3 M

NO.	FREQ. (MHz)	EMISSION LEVEL (dBuV/m)	LIMIT (dBuV/m)	MARGIN (dB)	ANTENNA HEIGHT (m)	TABLE ANGLE (Degree)	RAW VALUE (dBuV)	CORRECTION FACTOR (dB/m)
1	2375.00	60.3 PK	74.0	-13.7	1.34 H	289	28.90	31.40
2	2375.00	50.1 AV	54.0	-3.9	1.34 H	289	18.70	31.40
3	2390.00	65.6 PK	74.0	-8.4	1.34 H	303	34.20	31.40
4	2390.00	52.7 AV	54.0	-1.3	1.34 H	303	21.30	31.40
5	*2437.00	102.7 PK			1.34 H	289	71.10	31.60
6	*2437.00	89.6 AV			1.34 H	289	58.00	31.60
7	4874.00	45.5 PK	74.0	-28.5	1.23 H	227	7.90	37.60
8	4874.00	34.1 AV	54.0	-19.9	1.23 H	227	-3.50	37.60

ANTENNA POLARITY & TEST DISTANCE: VERTICAL AT 3 M

NO.	FREQ. (MHz)	EMISSION LEVEL (dBuV/m)	LIMIT (dBuV/m)	MARGIN (dB)	ANTENNA HEIGHT (m)	TABLE ANGLE (Degree)	RAW VALUE (dBuV)	CORRECTION FACTOR (dB/m)
1	2375.00	58.7 PK	74.0	-15.3	1.58 V	65	27.30	31.40
2	2375.00	47.5 AV	54.0	-6.5	1.58 V	65	16.10	31.40
3	2390.00	60.3 PK	74.0	-13.7	1.58 V	62	28.90	31.40
4	2390.00	48.1 AV	54.0	-5.9	1.58 V	62	16.70	31.40
5	*2437.00	98.0 PK			1.57 V	58	66.40	31.60
6	*2437.00	86.2 AV			1.57 V	58	54.60	31.60
7	4874.00	43.7 PK	74.0	-30.3	1.38 V	277	6.10	37.60
8	4874.00	33.0 AV	54.0	-21.0	1.38 V	277	-4.60	37.60

- REMARKS:**
1. Emission level (dBuV/m) = Raw Value (dBuV) + Correction Factor (dB/m).
 2. Correction Factor (dB/m) = Antenna Factor (dB/m) + Cable Factor (dB).
 3. The other emission levels were very low against the limit.
 4. Margin value = Emission level – Limit value.
 5. “ * “: Fundamental frequency.



A D T

EUT TEST CONDITION		MEASUREMENT DETAIL	
CHANNEL	Channel 7	FREQUENCY RANGE	1 ~ 25GHz
INPUT POWER	120Vac, 60 Hz	DETECTOR FUNCTION	Peak (PK) Average (AV)
ENVIRONMENTAL CONDITIONS	25deg. C, 68%RH	TESTED BY	Sun Lin

ANTENNA POLARITY & TEST DISTANCE: HORIZONTAL AT 3 M								
NO.	FREQ. (MHz)	EMISSION LEVEL (dBuV/m)	LIMIT (dBuV/m)	MARGIN (dB)	ANTENNA HEIGHT (m)	TABLE ANGLE (Degree)	RAW VALUE (dBuV)	CORRECTION FACTOR (dB/m)
1	2375.00	58.9 PK	74.0	-15.1	1.28 H	299	27.50	31.40
2	2375.00	49.2 AV	54.0	-4.8	1.28 H	299	17.80	31.40
3	*2452.00	103.0 PK			1.30 H	293	71.40	31.60
4	*2452.00	90.0 AV			1.30 H	293	58.40	31.60
5	2483.50	67.0 PK	74.0	-7.0	1.30 H	289	35.20	31.80
6	2483.50	52.8 AV	54.0	-1.2	1.30 H	289	21.00	31.80
7	4904.00	45.7 PK	74.0	-28.3	1.22 H	213	8.00	37.70
8	4904.00	34.6 AV	54.0	-19.4	1.22 H	213	-3.10	37.70
ANTENNA POLARITY & TEST DISTANCE: VERTICAL AT 3 M								
NO.	FREQ. (MHz)	EMISSION LEVEL (dBuV/m)	LIMIT (dBuV/m)	MARGIN (dB)	ANTENNA HEIGHT (m)	TABLE ANGLE (Degree)	RAW VALUE (dBuV)	CORRECTION FACTOR (dB/m)
1	2375.00	56.8 PK	74.0	-17.2	1.67 V	53	25.40	31.40
2	2375.00	47.2 AV	54.0	-6.8	1.67 V	53	15.80	31.40
3	*2452.00	98.6 PK			1.65 V	58	67.00	31.60
4	*2452.00	86.7 AV			1.65 V	58	55.10	31.60
5	2483.50	58.7 PK	74.0	-15.3	1.64 V	56	26.90	31.80
6	2483.50	48.7 AV	54.0	-5.3	1.64 V	56	16.90	31.80
7	4904.00	43.5 PK	74.0	-30.5	1.45 V	302	5.80	37.70
8	4904.00	33.4 AV	54.0	-20.6	1.45 V	302	-4.30	37.70

- REMARKS:**
1. Emission level (dBuV/m) = Raw Value (dBuV) + Correction Factor (dB/m).
 2. Correction Factor (dB/m) = Antenna Factor (dB/m) + Cable Factor (dB).
 3. The other emission levels were very low against the limit.
 4. Margin value = Emission level – Limit value.
 5. “ * “: Fundamental frequency.



A D T

BELOW 1GHz WORST-CASE DATA : 802.11n (20MHz)

EUT TEST CONDITION		MEASUREMENT DETAIL	
CHANNEL	Channel 6	FREQUENCY RANGE	Below 1000MHz
INPUT POWER	120Vac, 60 Hz	DETECTOR FUNCTION	Quasi-Peak
ENVIRONMENTAL CONDITIONS	25deg. C, 68%RH	TESTED BY	Sun Lin
Test Mode	A		

ANTENNA POLARITY & TEST DISTANCE: HORIZONTAL AT 3 M

NO.	FREQ. (MHz)	EMISSION LEVEL (dBuV/m)	LIMIT (dBuV/m)	MARGIN (dB)	ANTENNA HEIGHT (m)	TABLE ANGLE (Degree)	RAW VALUE (dBuV)	CORRECTION FACTOR (dB/m)
1	138.86	28.0 QP	43.5	-15.5	2.00 H	310	14.50	13.50
2	249.66	33.2 QP	46.0	-12.8	1.25 H	298	20.10	13.10
3	376.01	32.4 QP	46.0	-13.6	1.00 H	193	15.50	16.90
4	500.42	35.5 QP	46.0	-10.5	1.50 H	244	15.30	20.20
5	626.77	32.1 QP	46.0	-13.9	1.25 H	136	9.50	22.60
6	722.02	36.2 QP	46.0	-9.8	1.00 H	49	12.80	23.40

ANTENNA POLARITY & TEST DISTANCE: VERTICAL AT 3 M

NO.	FREQ. (MHz)	EMISSION LEVEL (dBuV/m)	LIMIT (dBuV/m)	MARGIN (dB)	ANTENNA HEIGHT (m)	TABLE ANGLE (Degree)	RAW VALUE (dBuV)	CORRECTION FACTOR (dB/m)
1	30.00	36.6 QP	40.0	-3.4	1.25 V	199	24.20	12.40
2	64.99	36.0 QP	40.0	-4.0	1.25 V	34	23.00	13.00
3	140.80	33.1 QP	43.5	-10.4	1.00 V	199	19.40	13.70
4	249.66	29.8 QP	46.0	-16.2	1.00 V	283	16.70	13.10
5	376.01	31.0 QP	46.0	-15.0	1.00 V	196	14.10	16.90
6	722.02	34.4 QP	46.0	-11.6	1.50 V	154	11.00	23.40

- REMARKS:**
1. Emission level (dBuV/m) = Raw Value (dBuV) + Correction Factor (dB/m).
 2. Correction Factor (dB/m) = Antenna Factor (dB/m) + Cable Factor (dB).
 3. The other emission levels were very low against the limit.
 4. Margin value = Emission level – Limit value.



A D T

EUT TEST CONDITION		MEASUREMENT DETAIL	
CHANNEL	Channel 6	FREQUENCY RANGE	Below 1000MHz
INPUT POWER (SYSTEM)	120Vac, 60 Hz	DETECTOR FUNCTION	Quasi-Peak
ENVIRONMENTAL CONDITIONS	25deg. C, 65%RH	TESTED BY	Sun Lin
Test Mode	B		

ANTENNA POLARITY & TEST DISTANCE: HORIZONTAL AT 3 M								
NO.	FREQ. (MHz)	EMISSION LEVEL (dBuV/m)	LIMIT (dBuV/m)	MARGIN (dB)	ANTENNA HEIGHT (m)	TABLE ANGLE (Degree)	RAW VALUE (dBuV)	CORRECTION FACTOR (dB/m)
1	96.09	30.0 QP	43.5	-13.5	2.00 H	259	21.00	9.00
2	249.66	28.4 QP	46.0	-17.6	1.00 H	151	15.30	13.10
3	376.01	30.9 QP	46.0	-15.1	1.00 H	130	14.00	16.90
4	500.42	39.9 QP	46.0	-6.1	1.50 H	214	19.70	20.20
5	626.77	34.7 QP	46.0	-11.3	1.25 H	208	12.10	22.60
6	722.02	40.0 QP	46.0	-6.0	1.25 H	10	16.60	23.40
ANTENNA POLARITY & TEST DISTANCE: VERTICAL AT 3 M								
NO.	FREQ. (MHz)	EMISSION LEVEL (dBuV/m)	LIMIT (dBuV/m)	MARGIN (dB)	ANTENNA HEIGHT (m)	TABLE ANGLE (Degree)	RAW VALUE (dBuV)	CORRECTION FACTOR (dB/m)
1	98.04	33.2 QP	43.5	-10.3	1.25 V	322	23.90	9.30
2	243.83	28.9 QP	46.0	-17.1	1.00 V	136	16.00	12.90
3	376.01	27.8 QP	46.0	-18.2	1.25 V	211	10.90	16.90
4	500.42	29.9 QP	46.0	-16.1	1.00 V	160	9.70	20.20
5	626.77	29.7 QP	46.0	-16.3	1.25 V	193	7.10	22.60
6	722.02	32.5 QP	46.0	-13.5	1.50 V	127	9.10	23.40

- REMARKS:**
1. Emission level (dBuV/m) = Raw Value (dBuV) + Correction Factor (dB/m).
 2. Correction Factor (dB/m) = Antenna Factor (dB/m) + Cable Factor (dB).
 3. The other emission levels were very low against the limit.
 4. Margin value = Emission level – Limit value.



A D T

EUT TEST CONDITION		MEASUREMENT DETAIL	
CHANNEL	Channel 6	FREQUENCY RANGE	Below 1000MHz
INPUT POWER (SYSTEM)	120Vac, 60 Hz	DETECTOR FUNCTION	Quasi-Peak
ENVIRONMENTAL CONDITIONS	25deg. C, 65%RH	TESTED BY	Anderson Hong
Test Mode	C		

ANTENNA POLARITY & TEST DISTANCE: HORIZONTAL AT 3 M

NO.	FREQ. (MHz)	EMISSION LEVEL (dBuV/m)	LIMIT (dBuV/m)	MARGIN (dB)	ANTENNA HEIGHT (m)	TABLE ANGLE (Degree)	RAW VALUE (dBuV)	CORRECTION FACTOR (dB/m)
1	167.74	39.3 QP	43.5	-4.2	1.50 H	81	25.70	13.60
2	189.08	37.4 QP	43.5	-6.1	1.50 H	289	25.40	12.00
3	375.32	36.6 QP	46.0	-9.4	1.00 H	15	19.80	16.80
4	499.48	36.6 QP	46.0	-9.4	1.50 H	3	16.50	20.10
5	625.58	33.0 QP	46.0	-13.0	1.25 H	310	10.50	22.50
6	720.64	37.1 QP	46.0	-8.9	1.00 H	202	13.80	23.30

ANTENNA POLARITY & TEST DISTANCE: VERTICAL AT 3 M

NO.	FREQ. (MHz)	EMISSION LEVEL (dBuV/m)	LIMIT (dBuV/m)	MARGIN (dB)	ANTENNA HEIGHT (m)	TABLE ANGLE (Degree)	RAW VALUE (dBuV)	CORRECTION FACTOR (dB/m)
1	57.16	38.0 QP	40.0	-2.0	1.00 V	163	24.40	13.60
2	88.20	33.1 QP	43.5	-10.4	1.00 V	25	24.50	8.60
3	167.74	34.2 QP	43.5	-9.3	1.00 V	301	20.60	13.60
4	375.32	36.4 QP	46.0	-9.6	1.00 V	4	19.60	16.80
5	499.48	33.7 QP	46.0	-12.3	1.00 V	65	13.60	20.10
6	720.64	35.5 QP	46.0	-10.5	1.50 V	339	12.20	23.30

REMARKS:

1. Emission level (dBuV/m) = Raw Value (dBuV) + Correction Factor (dB/m).
2. Correction Factor (dB/m) = Antenna Factor (dB/m) + Cable Factor (dB).
3. The other emission levels were very low against the limit.
4. Margin value = Emission level – Limit value.

4.2 CONDUCTED EMISSION MEASUREMENT

4.2.1 MITS OF CONDUCTED EMISSION MEASUREMENT

FREQUENCY OF EMISSION (MHz)	CONDUCTED LIMIT (dB μ V)	
	Quasi-peak	Average
0.15 ~ 0.5	66 to 56	56 to 46
0.5 ~ 5	56	46
5 ~ 30	60	50

- NOTE:**
1. The lower limit shall apply at the transition frequencies.
 2. The limit decreases in line with the logarithm of the frequency in the range of 0.15 to 0.50MHz.
 3. All emanations from a class A/B digital device or system, including any network of conductors and apparatus connected thereto, shall not exceed the level of field strengths specified above.

4.2.2 TEST INSTRUMENTS

DESCRIPTION & MANUFACTURER	MODEL NO.	SERIAL NO.	DATE OF CALIBRATION	DUE DATE OF CALIBRATION
Test Receiver ROHDE & SCHWARZ	ESCS30	100289	Nov. 19, 2011	Nov. 18, 2012
RF signal cable Woken	5D-FB	Cable-HYCO2-01	Dec. 22, 2011	Dec. 21, 2012
LISN ROHDE & SCHWARZ	ESH2-Z5	100100	Dec. 30, 2011	Dec. 29, 2012
LISN ROHDE & SCHWARZ	ESH3-Z5	100312	Jul. 07, 2011	Jul. 06, 2012
V-LISN SCHWARZBECK	NNBL 8226-2	8226-142	Jun. 30, 2011	Jun. 29, 2012
LISN ROHDE & SCHWARZ	ENV216	100072	Jun. 10, 2011	Jun. 09, 2012
Software ADT	ADT_Cond_ V7.3.7	NA	NA	NA

- NOTE:**
1. The calibration interval of the above test instruments is 12 months and the calibrations are traceable to NML/ROC and NIST/USA.
 2. The test was performed in HwaYa Shielded Room 2.
 3. The VCCI Site Registration No. is C-2047.

4.2.3 TEST PROCEDURES

- a. The EUT was placed 0.4 meters from the conducting wall of the shielded room with EUT being connected to the power mains through a line impedance stabilization network (LISN). Other support units were connected to the power mains through another LISN. The two LISNs provide 50 ohm/ 50uH of coupling impedance for the measuring instrument.
- b. Both lines of the power mains connected to the EUT were checked for maximum conducted interference.
- c. The frequency range from 150kHz to 30MHz was searched. Emission levels under (Limit - 20dB) was not recorded.

NOTE: All modes of operation were investigated and the worst-case emissions are reported.

4.2.4 DEVIATION FROM TEST STANDARD

No deviation.

4.2.5 TEST SETUP

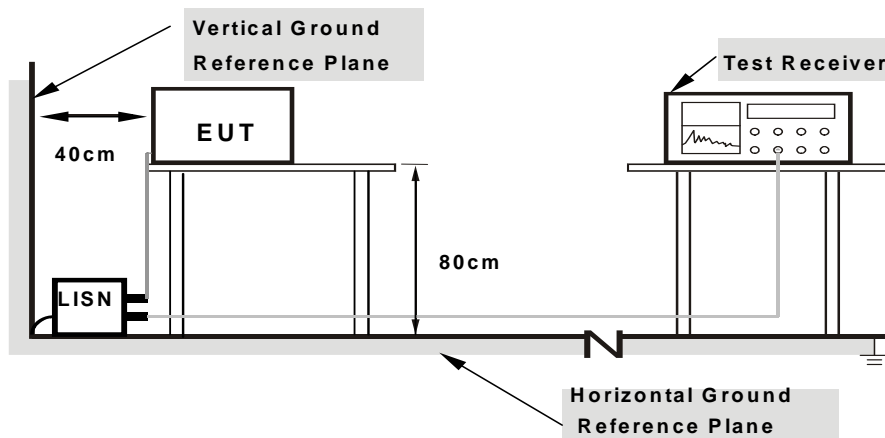

- Note:**
1. Support units were connected to second LISN.
 2. Both of LISNs (AMN) are 80 cm from EUT and at least 80 cm from other units and other metal planes

For the actual test configuration, please refer to the attached file (Test Setup Photo).

4.2.6 EUT OPERATING CONDITIONS

Same as 4.1.6.

4.2.7 TEST RESULTS

CONDUCTED WORST-CASE DATA : 802.11n (20MHz)

PHASE	Line 1	6dB BANDWIDTH	9kHz
TEST MODE	A		

No	Freq. [MHz]	Corr.	Reading Value		Emission Level		Limit		Margin	
		Factor	[dB (uV)]		[dB (uV)]		[dB (uV)]		(dB)	
		(dB)	Q.P.	AV.	Q.P.	AV.	Q.P.	AV.	Q.P.	AV.
1	0.15000	0.15	48.65	39.27	48.80	39.42	66.00	56.00	-17.20	-16.58
2	0.18125	0.15	42.32	29.67	42.47	29.82	64.43	54.43	-21.96	-24.61
3	0.36094	0.17	38.20	28.05	38.37	28.22	58.71	48.71	-20.34	-20.49
4	0.48594	0.17	34.08	21.46	34.25	21.63	56.24	46.24	-21.98	-24.60
5	0.66563	0.18	31.90	21.74	32.08	21.92	56.00	46.00	-23.92	-24.08
6	2.33203	0.27	30.84	18.87	31.11	19.14	56.00	46.00	-24.89	-26.86

- REMARKS:**
1. Q.P. and AV. are abbreviations of quasi-peak and average individually.
 2. The emission levels of other frequencies were very low against the limit.
 3. Margin value = Emission level - Limit value
 4. Correction factor = Insertion loss + Cable loss
 5. Emission Level = Correction Factor + Reading Value.

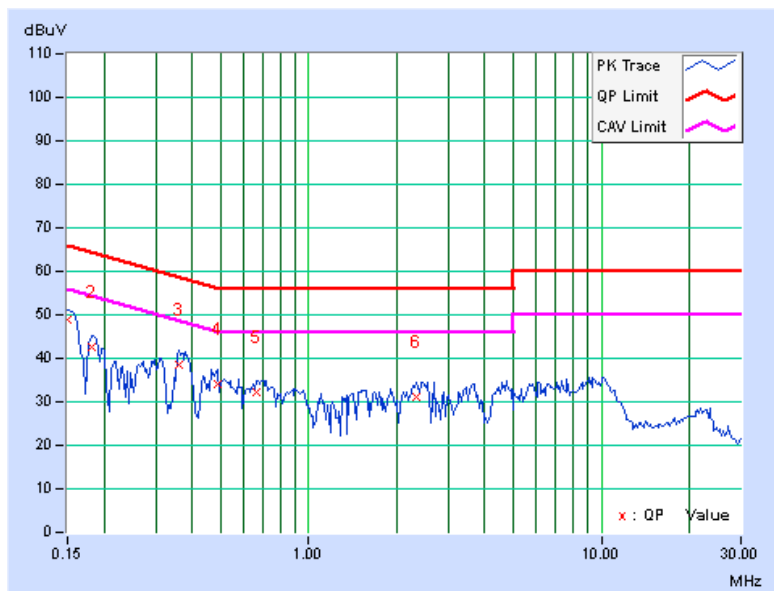

PHASE	Line 2	6dB BANDWIDTH	9kHz
TEST MODE	A		

No	Freq. [MHz]	Corr.	Reading Value		Emission Level		Limit		Margin	
		Factor	[dB (uV)]		[dB (uV)]		[dB (uV)]		(dB)	
		(dB)	Q.P.	AV.	Q.P.	AV.	Q.P.	AV.	Q.P.	AV.
1	0.15781	0.13	46.31	29.85	46.44	29.98	65.58	55.58	-19.14	-25.60
2	0.18516	0.14	40.74	27.58	40.88	27.72	64.25	54.25	-23.37	-26.53
3	0.36094	0.16	38.40	28.09	38.56	28.25	58.71	48.71	-20.15	-20.46
4	0.95078	0.19	33.69	22.41	33.88	22.60	56.00	46.00	-22.12	-23.40
5	2.12500	0.27	32.75	22.15	33.02	22.42	56.00	46.00	-22.98	-23.58
6	3.63672	0.33	31.22	22.09	31.55	22.42	56.00	46.00	-24.45	-23.58

- REMARKS:**
1. Q.P. and AV. are abbreviations of quasi-peak and average individually.
 2. The emission levels of other frequencies were very low against the limit.
 3. Margin value = Emission level - Limit value
 4. Correction factor = Insertion loss + Cable loss
 5. Emission Level = Correction Factor + Reading Value.

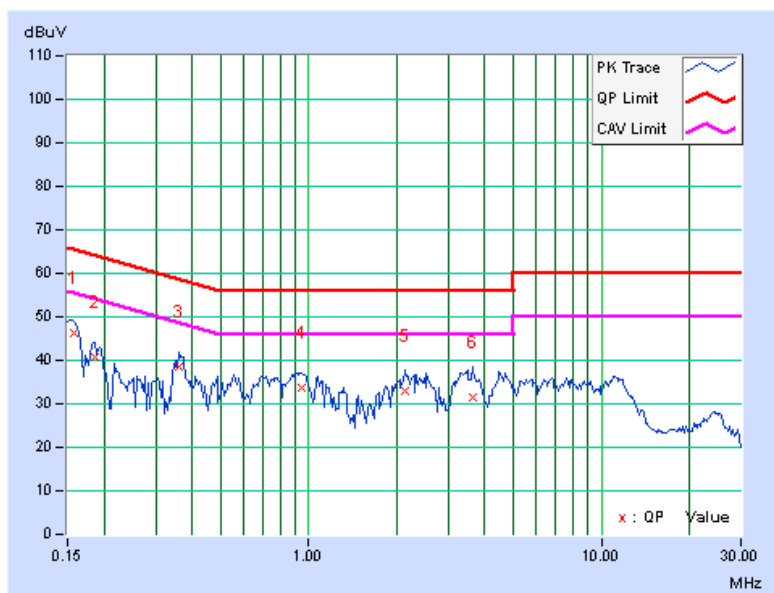



A D T

PHASE	Line 1	6dB BANDWIDTH	9kHz
Test Mode	B		

No	Freq. [MHz]	Corr. Factor (dB)	Reading Value		Emission Level		Limit		Margin	
			[dB (uV)]		[dB (uV)]		[dB (uV)]		(dB)	
			Q.P.	AV.	Q.P.	AV.	Q.P.	AV.	Q.P.	AV.
1	0.15000	0.15	40.65	30.20	40.80	30.35	66.00	56.00	-25.20	-25.65
2	0.18125	0.15	37.66	33.24	37.81	33.39	64.43	54.43	-26.62	-21.04
3	0.23594	0.15	32.82	27.41	32.97	27.56	62.24	52.24	-29.26	-24.67
4	0.42734	0.17	30.18	23.09	30.35	23.26	57.30	47.30	-26.95	-24.04
5	2.61328	0.28	28.98	20.29	29.26	20.57	56.00	46.00	-26.74	-25.43
6	29.85541	0.51	43.56	42.69	44.07	43.20	60.00	50.00	-15.93	-6.80

- REMARKS:**
1. Q.P. and AV. are abbreviations of quasi-peak and average individually.
 2. The emission levels of other frequencies were very low against the limit.
 3. Margin value = Emission level - Limit value
 4. Correction factor = Insertion loss + Cable loss
 5. Emission Level = Correction Factor + Reading Value.

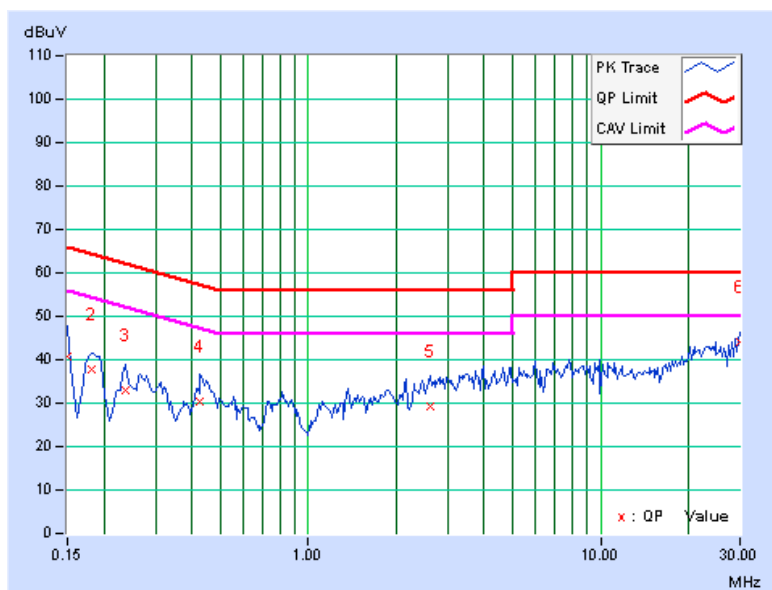



A D T

PHASE	Line 2	6dB BANDWIDTH	9kHz
Test Mode	B		

No	Freq. [MHz]	Corr.	Reading Value		Emission Level		Limit		Margin	
		Factor	[dB (uV)]		[dB (uV)]		[dB (uV)]		(dB)	
		(dB)	Q.P.	AV.	Q.P.	AV.	Q.P.	AV.	Q.P.	AV.
1	0.15000	0.13	40.39	30.10	40.52	30.23	66.00	56.00	-25.48	-25.77
2	0.18125	0.14	37.13	33.36	37.27	33.50	64.43	54.43	-27.16	-20.93
3	0.45469	0.16	32.66	27.37	32.82	27.53	56.79	46.79	-23.97	-19.26
4	0.82188	0.18	28.73	21.76	28.91	21.94	56.00	46.00	-27.09	-24.06
5	2.72656	0.29	31.08	22.32	31.37	22.61	56.00	46.00	-24.63	-23.39
6	28.20306	0.57	42.63	41.67	43.20	42.24	60.00	50.00	-16.80	-7.76

- REMARKS:**
1. Q.P. and AV. are abbreviations of quasi-peak and average individually.
 2. The emission levels of other frequencies were very low against the limit.
 3. Margin value = Emission level - Limit value
 4. Correction factor = Insertion loss + Cable loss
 5. Emission Level = Correction Factor + Reading Value.

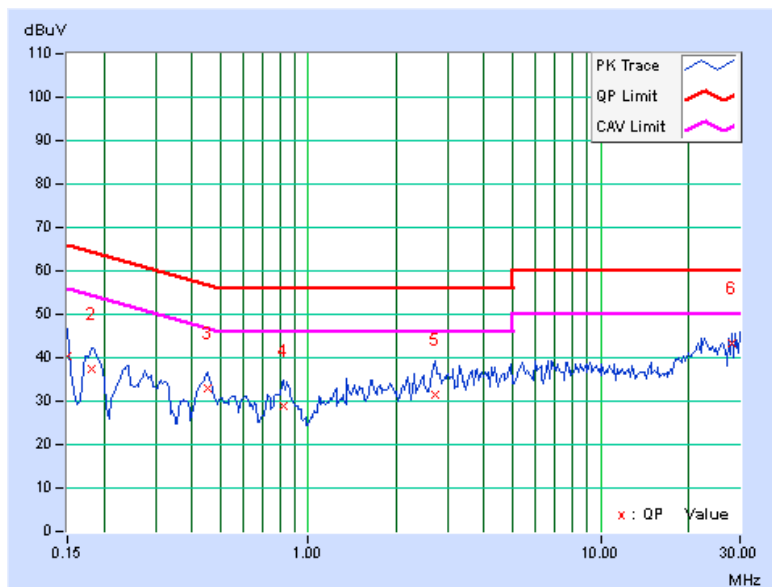



A D T

PHASE	Line 1	6dB BANDWIDTH	9kHz
Test Mode	C		

No	Freq.	Corr.	Reading Value		Emission Level		Limit		Margin	
	[MHz]	Factor	[dB (uV)]		[dB (uV)]		[dB (uV)]		(dB)	
		(dB)	Q.P.	AV.	Q.P.	AV.	Q.P.	AV.	Q.P.	AV.
1	0.15000	0.15	51.57	39.34	51.72	39.49	66.00	56.00	-14.28	-16.51
2	0.19687	0.15	45.39	34.86	45.54	35.01	63.74	53.74	-18.20	-18.73
3	0.62656	0.18	28.27	20.13	28.45	20.31	56.00	46.00	-27.55	-25.69
4	4.18750	0.34	20.72	11.35	21.06	11.69	56.00	46.00	-34.94	-34.31
5	5.02344	0.36	20.76	11.23	21.12	11.59	60.00	50.00	-38.88	-38.41
6	20.69141	0.62	19.26	12.24	19.88	12.86	60.00	50.00	-40.12	-37.14

- REMARKS:**
1. Q.P. and AV. are abbreviations of quasi-peak and average individually.
 2. The emission levels of other frequencies were very low against the limit.
 3. Margin value = Emission level - Limit value
 4. Correction factor = Insertion loss + Cable loss
 5. Emission Level = Correction Factor + Reading Value.

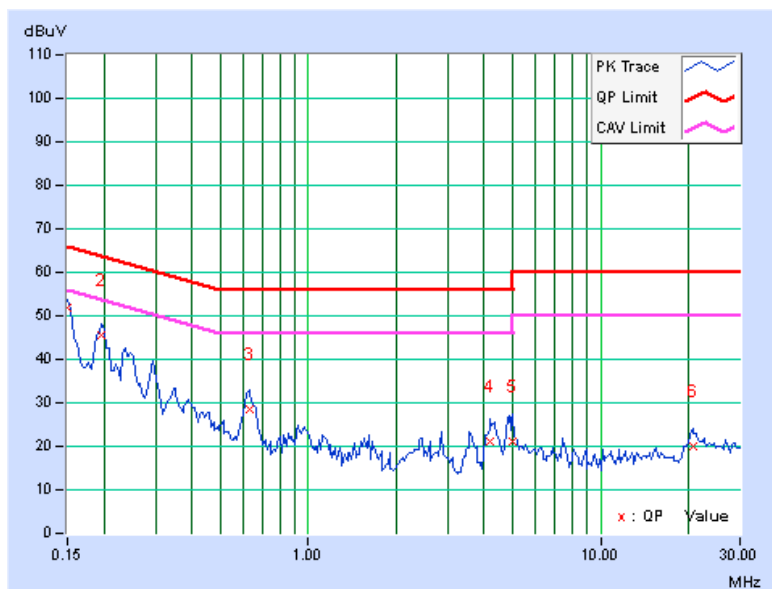

PHASE	Line 2	6dB BANDWIDTH	9kHz
Test Mode	C		

No	Freq. [MHz]	Corr. Factor (dB)	Reading Value		Emission Level		Limit		Margin	
			[dB (uV)]		[dB (uV)]		[dB (uV)]		(dB)	
			Q.P.	AV.	Q.P.	AV.	Q.P.	AV.	Q.P.	AV.
1	0.19687	0.14	47.67	38.42	47.81	38.56	63.74	53.74	-15.93	-15.18
2	0.24375	0.14	41.65	32.80	41.79	32.94	61.97	51.97	-20.17	-19.02
3	0.62656	0.17	30.87	25.99	31.04	26.16	56.00	46.00	-24.96	-19.84
4	4.14844	0.35	23.29	12.34	23.64	12.69	56.00	46.00	-32.36	-33.31
5	9.42969	0.47	13.78	8.52	14.25	8.99	60.00	50.00	-45.75	-41.01
6	20.91797	0.70	23.58	18.68	24.28	19.38	60.00	50.00	-35.72	-30.62

- REMARKS:**
1. Q.P. and AV. are abbreviations of quasi-peak and average individually.
 2. The emission levels of other frequencies were very low against the limit.
 3. Margin value = Emission level - Limit value
 4. Correction factor = Insertion loss + Cable loss
 5. Emission Level = Correction Factor + Reading Value.

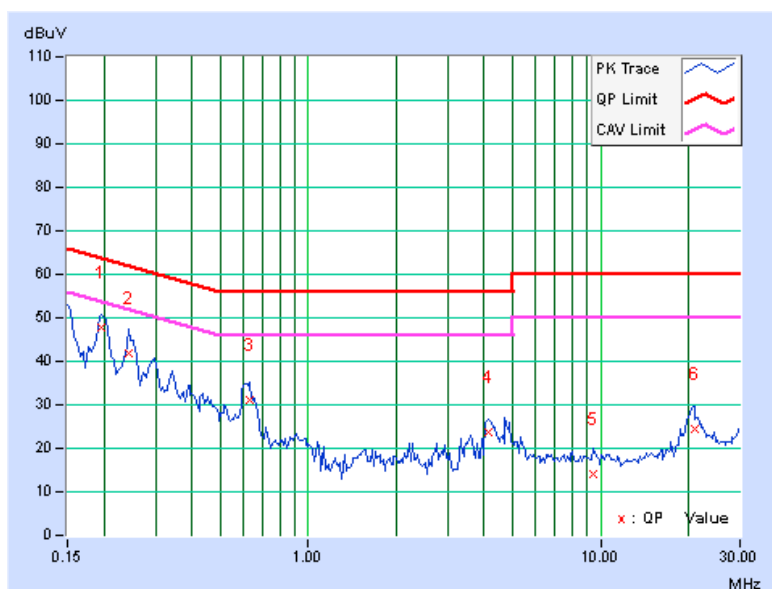

4.3 6dB BANDWIDTH MEASUREMENT

4.3.1 LIMITS OF 6dB BANDWIDTH MEASUREMENT

The minimum of 6dB Bandwidth Measurement is 0.5 MHz.

4.3.2 TEST SETUP

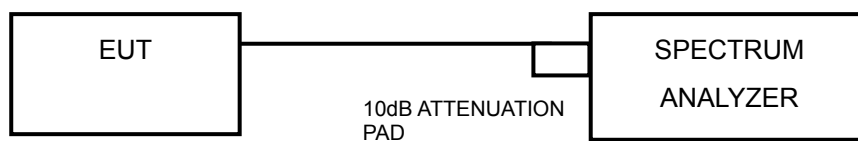

4.3.3 TEST INSTRUMENTS

Refer to section 4.1.2 to get information of above instrument.

4.3.4 TEST PROCEDURE

- a. Set resolution bandwidth (RBW) = approximately 1% of the emission bandwidth
- b. Set the video bandwidth (VBW) $\geq 3 \times$ RBW, Detector = Peak.
- c. Trace mode = max hold.
- d. Sweep = auto couple.
- e. Measure the maximum width of the emission that is constrained by the frequencies associated with the two amplitude points (upper and lower) that are attenuated by 6 dB relative to the maximum level measured in the fundamental emission

4.3.5 DEVIATION FROM TEST STANDARD

No deviation.

4.3.6 EUT OPERATING CONDITIONS

The software provided by client to enable the EUT under transmission condition continuously at lowest, middle and highest channel frequencies individually.



4.3.7 TEST RESULTS

802.11b

CHANNEL	FREQUENCY (MHz)	6dB BANDWIDTH (MHz)		MINIMUM LIMIT (MHz)	PASS / FAIL
		CHAIN 0	CHAIN 1		
1	2412	10.29	10.28	0.5	PASS
6	2437	10.29	10.30	0.5	PASS
11	2462	10.29	10.28	0.5	PASS

802.11g

CHANNEL	FREQUENCY (MHz)	6dB BANDWIDTH (MHz)		MINIMUM LIMIT (MHz)	PASS / FAIL
		CHAIN 0	CHAIN 1		
1	2412	16.58	16.49	0.5	PASS
6	2437	16.56	16.56	0.5	PASS
11	2462	16.61	16.58	0.5	PASS

802.11n (20MHz)

CHANNEL	FREQUENCY (MHz)	6dB BANDWIDTH (MHz)		MINIMUM LIMIT (MHz)	PASS / FAIL
		CHAIN 0	CHAIN 1		
1	2412	17.70	17.80	0.5	PASS
6	2437	17.73	17.84	0.5	PASS
11	2462	17.70	17.84	0.5	PASS

802.11n (40MHz)

CHANNEL	FREQUENCY (MHz)	6dB BANDWIDTH (MHz)		MINIMUM LIMIT (MHz)	PASS / FAIL
		CHAIN 0	CHAIN 1		
1	2422	37.26	36.65	0.5	PASS
4	2437	36.78	36.75	0.5	PASS
7	2452	36.64	36.92	0.5	PASS

4.4 CONDUCTED OUTPUT POWER

4.4.1 LIMITS OF CONDUCTED OUTPUT POWER MEASUREMENT

For systems using digital modulation in the 2400–2483.5 MHz bands: 1 Watt (30dBm)

4.4.2 TEST SETUP

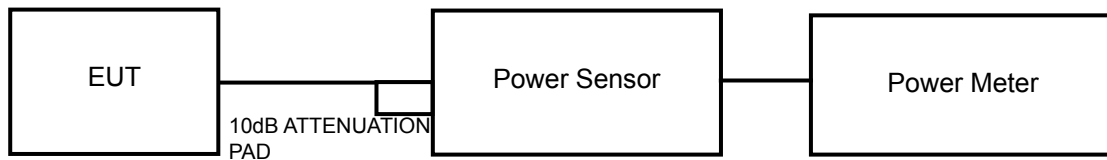

4.4.3 TEST INSTRUMENTS

Refer to section 4.1.2 to get information of above instrument.

4.4.4 TEST PROCEDURES

A peak power sensor was used on the output port of the EUT. A power meter was used to read the response of the peak power sensor. Record the peak power level.

4.4.5 DEVIATION FROM TEST STANDARD

No deviation.

4.4.6 EUT OPERATING CONDITIONS

Same as Item 4.3.6.



4.4.7 TEST RESULTS

802.11b

CHAN.	FREQUENCY (MHz)	PEAK POWER (dBm)		TOTAL POWER (mW)	TOTAL POWER (dBm)	LIMIT (dBm)	PASS / FAIL
		CHAIN 0	CHAIN 1				
1	2412	22.67	22.71	371.57	25.70	30	PASS
6	2437	22.38	22.22	339.71	25.31	30	PASS
11	2462	21.83	23.02	352.85	25.48	30	PASS

NOTE: Directional gain = 2dBi + 10log(2) = 5dBi < 6dBi , so the conducted power limit is not reduced.

802.11g

CHAN.	FREQUENCY (MHz)	PEAK POWER (dBm)		TOTAL POWER (mW)	TOTAL POWER (dBm)	LIMIT (dBm)	PASS / FAIL
		CHAIN 0	CHAIN 1				
1	2412	24.71	25.32	636.21	28.04	30	PASS
6	2437	26.13	26.21	828.03	29.18	30	PASS
11	2462	25.75	25.31	715.46	28.55	30	PASS

NOTE: Directional gain = 2dBi + 10log(2) = 5dBi < 6dBi , so the conducted power limit is not reduced.

802.11n (20MHz)

CHAN.	FREQUENCY (MHz)	PEAK POWER (dBm)		TOTAL POWER (mW)	TOTAL POWER (dBm)	LIMIT (dBm)	PASS / FAIL
		CHAIN 0	CHAIN 1				
1	2412	24.62	24.97	603.79	27.81	30	PASS
6	2437	26.17	26.31	841.56	29.25	30	PASS
11	2462	26.12	26.21	827.09	29.18	30	PASS

802.11n (40MHz)

CHAN.	FREQUENCY (MHz)	PEAK POWER (dBm)		TOTAL POWER (mW)	TOTAL POWER (dBm)	LIMIT (dBm)	PASS / FAIL
		CHAIN 0	CHAIN 1				
1	2422	20.62	20.32	222.99	23.48	30	PASS
4	2437	24.82	25.34	645.37	28.10	30	PASS
7	2452	25.18	25.32	670.02	28.26	30	PASS

4.5 POWER SPECTRAL DENSITY MEASUREMENT

4.5.1 LIMITS OF POWER SPECTRAL DENSITY MEASUREMENT

The Maximum of Power Spectral Density Measurement is 8dBm.

4.5.2 TEST SETUP

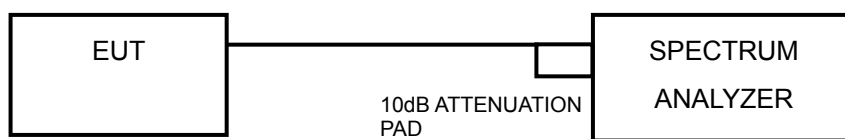

4.5.3 TEST INSTRUMENTS

Refer to section 4.1.2 to get information of above instrument.

4.5.4 TEST PROCEDURE

- a. Set the RBW = 100 kHz, VBW =300 kHz, Detector = peak.
- b. Sweep time = auto couple, Trace mode = max hold, allow trace to fully stabilize.
- c. Use the peak marker function to determine the maximum power level in any 100 kHz band segment within the fundamental EBW.
- d. Scale the observed power level to an equivalent value in 3 kHz by adjusting (reducing) the measured power by a bandwidth correction factor (BWCF) where $BWCF = 10\log(3 \text{ kHz}/100\text{kHz})$

4.5.5 DEVIATION FROM TEST STANDARD

No deviation.

4.5.6 EUT OPERATING CONDITION

Same as Item 4.3.6

4.5.7 TEST RESULTS

802.11b

TX chain	Channel	FREQ. (MHz)	PSD (dBm/100kHz)	PSD (dBm/3kHz)	10 log (N=2) dB	Total PSD (dBm/3kHz)	Limit (dBm/3kHz)	PASS /FAIL
0	1	2412	10.97	-4.26	3.01	-1.25	8	PASS
	6	2437	10.71	-4.52	3.01	-1.51	8	PASS
	11	2462	10.23	-5.00	3.01	-1.99	8	PASS
1	1	2412	10.97	-4.26	3.01	-1.25	8	PASS
	6	2437	10.50	-4.73	3.01	-1.72	8	PASS
	11	2462	11.32	-3.91	3.01	-0.90	8	PASS

NOTE: Directional gain = $2\text{dBi} + 10\log(2) = 5\text{dBi} < 6\text{dBi}$, so the power spectral density limit is not reduced.

802.11g

TX chain	Channel	FREQ. (MHz)	PSD (dBm/100kHz)	PSD (dBm/3kHz)	10 log (N=2) dB	Total PSD (dBm/3kHz)	Limit (dBm/3kHz)	PASS /FAIL
0	1	2412	4.19	-11.04	3.01	-8.03	8	PASS
	6	2437	5.80	-9.43	3.01	-6.42	8	PASS
	11	2462	5.45	-9.78	3.01	-6.77	8	PASS
1	1	2412	5.20	-10.03	3.01	-7.02	8	PASS
	6	2437	6.13	-9.10	3.01	-6.09	8	PASS
	11	2462	5.01	-10.22	3.01	-7.21	8	PASS

NOTE: Directional gain = $2\text{dBi} + 10\log(2) = 5\text{dBi} < 6\text{dBi}$, so the power spectral density limit is not reduced.

802.11n (20MHz)

TX chain	Channel	FREQ. (MHz)	PSD (dBm/100kHz)	PSD (dBm/3kHz)	10 log (N=2) dB	Total PSD (dBm/3kHz)	Limit (dBm/3kHz)	PASS /FAIL
0	1	2412	3.22	-12.01	3.01	-9.00	8	PASS
	6	2437	4.60	-10.63	3.01	-7.62	8	PASS
	11	2462	4.70	-10.53	3.01	-7.52	8	PASS
1	1	2412	4.09	-11.14	3.01	-8.13	8	PASS
	6	2437	5.64	-9.59	3.01	-6.58	8	PASS
	11	2462	5.12	-10.11	3.01	-7.10	8	PASS



A D T

802.11n (40MHz)

TX chain	Channel	FREQ. (MHz)	PSD (dBm/100kHz)	PSD (dBm/3kHz)	10 log (N=2) dB	Total PSD (dBm/3kHz)	Limit (dBm/3kHz)	PASS /FAIL
0	1	2422	-5.29	-20.52	3.01	-17.51	8	PASS
	4	2437	-1.16	-16.39	3.01	-13.38	8	PASS
	7	2452	-0.97	-16.20	3.01	-13.19	8	PASS
1	1	2422	-5.15	-20.38	3.01	-17.37	8	PASS
	4	2437	-0.16	-15.39	3.01	-12.38	8	PASS
	7	2452	-0.02	-15.25	3.01	-12.24	8	PASS

4.6 CONDUCTED OUT OF BAND EMISSION MEASUREMENT

4.6.1 LIMITS OF CONDUCTED OUT OF BAND EMISSION MEASUREMENT

Below -20dB of the highest emission level of operating band (in 100kHz Resolution Bandwidth).

4.6.2 TEST SETUP

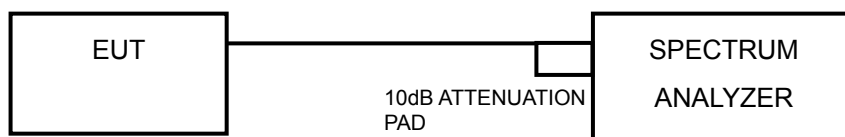

4.6.3 TEST INSTRUMENTS

Refer to section 4.1.2 to get information of above instrument.

4.6.4 TEST PROCEDURE

MEASUREMENT PROCEDURE REF

1. Set the RBW = 100 kHz.
2. Set the VBW \geq 300 kHz.
3. Detector = peak.
4. Sweep time = auto couple.
5. Trace mode = max hold.
6. Allow trace to fully stabilize.
7. Use the peak marker function to determine the maximum power level in any 100 kHz band segment within the fundamental EBW.

MEASUREMENT PROCEDURE OOB

1. Set RBW = 100 kHz.
2. Set VBW \geq 300 kHz.
3. Set span to encompass the spectrum to be examined.
4. Detector = peak.
5. Trace Mode = max hold.
6. Sweep = auto couple.

4.6.5 DEVIATION FROM TEST STANDARD

No deviation.

4.6.6 EUT OPERATING CONDITION

Same as Item 4.3.6

4.6.7 TEST RESULTS

The conducted emission test is performed on each TX port of operating mode without summing or adding $10\log(N)$ since the limit is relative emission limit. Only worst data of each operating mode is presented.

The spectrum plots are attached on the following pages. D1 line indicates the highest level, and D2 line indicates the 20dB offset below D1. It shows compliance with the requirement.



A D T

802.11b

CH 1

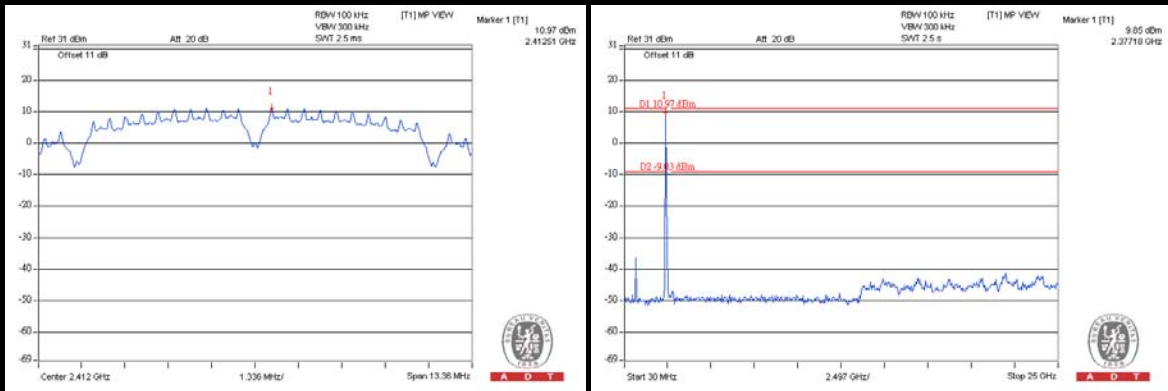

CH 6

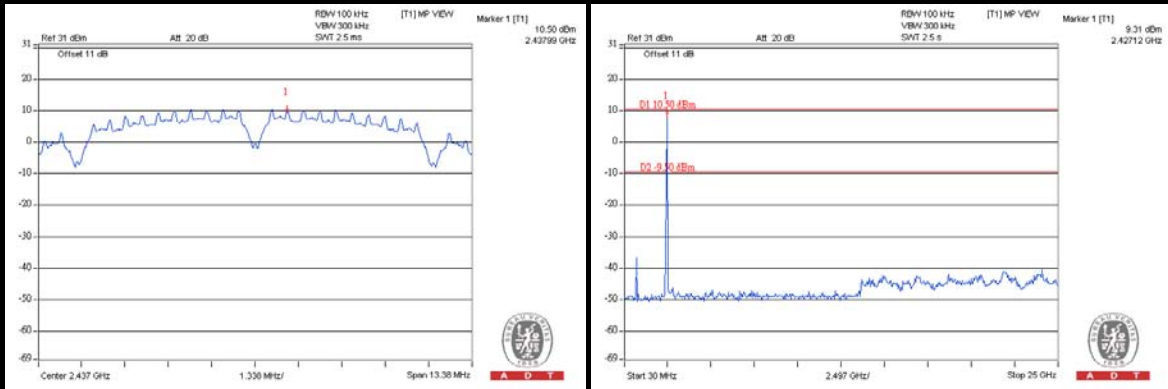

CH 11

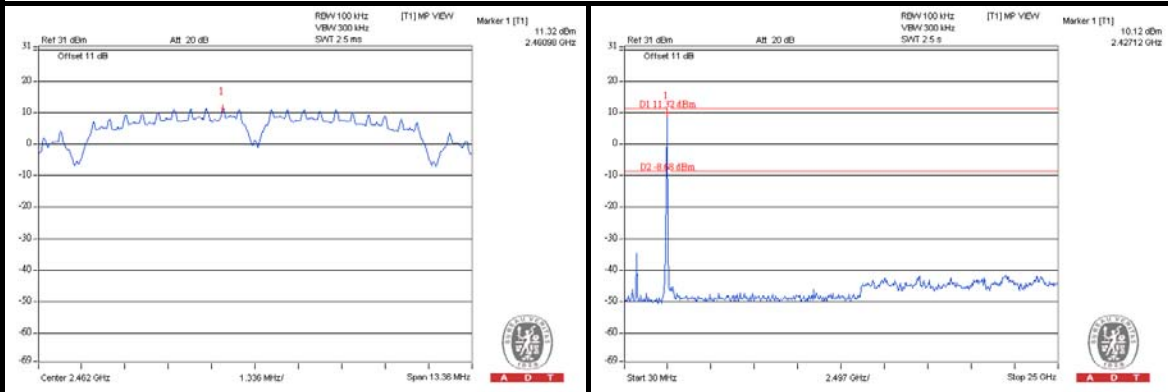



A D T

802.11g

CH 1

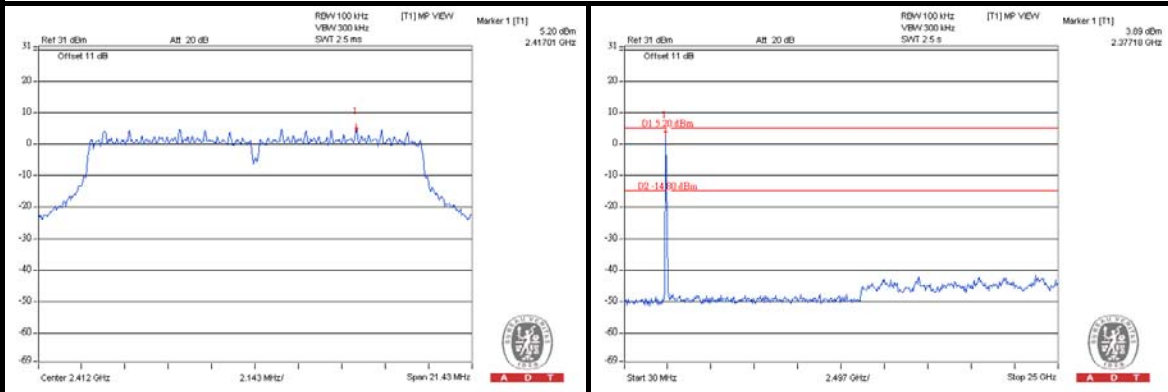

CH 6

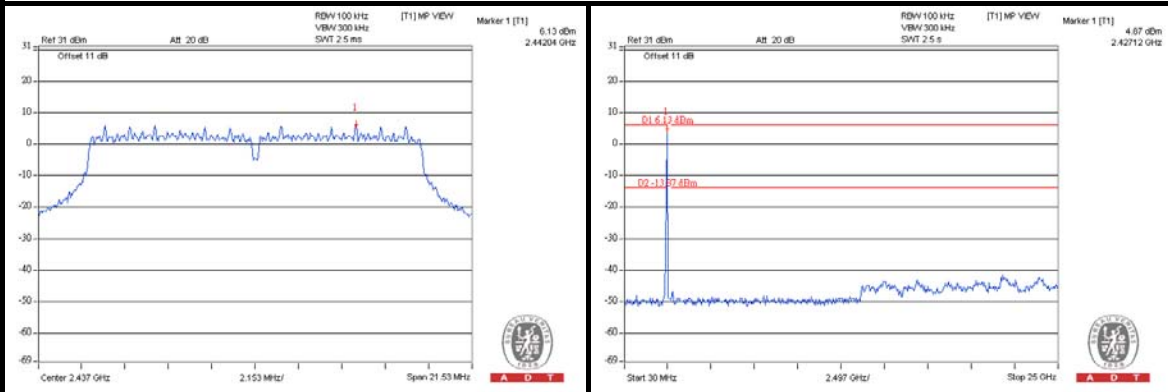

CH 11

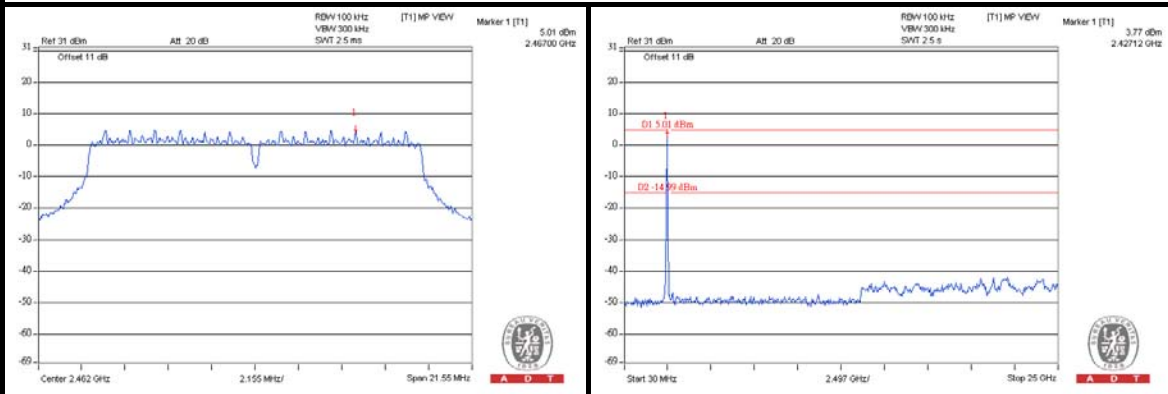



A D T

802.11n (20MHz)

CH 1

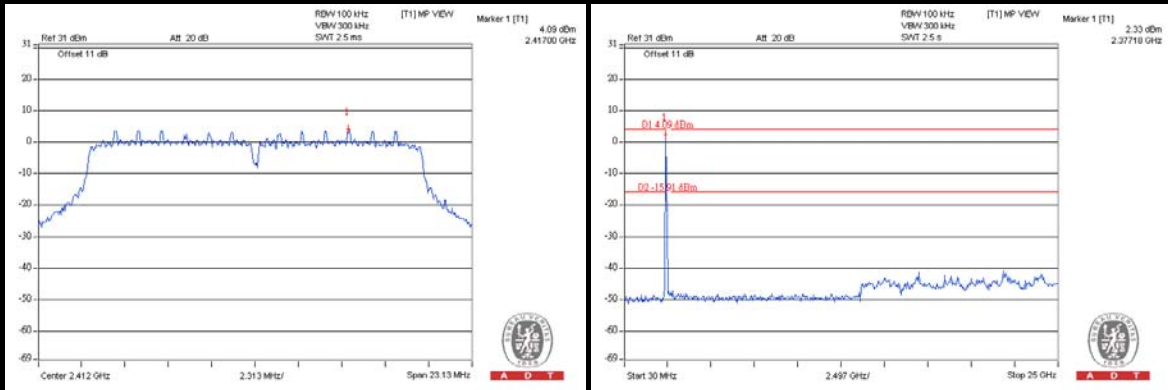

CH 6

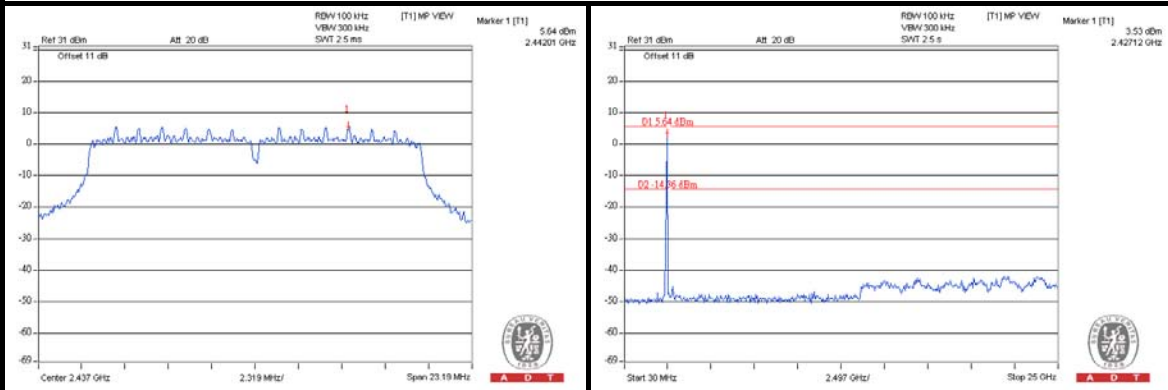

CH 11

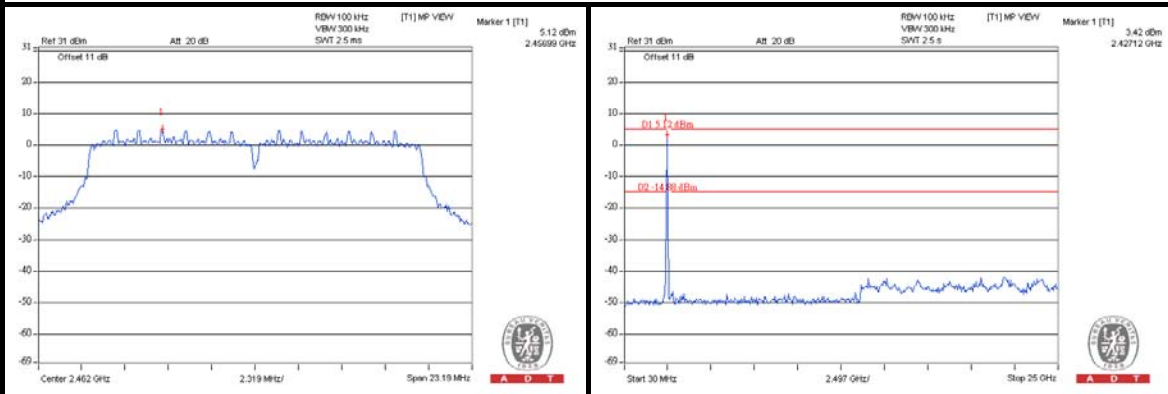

802.11n (40MHz)

CH 1

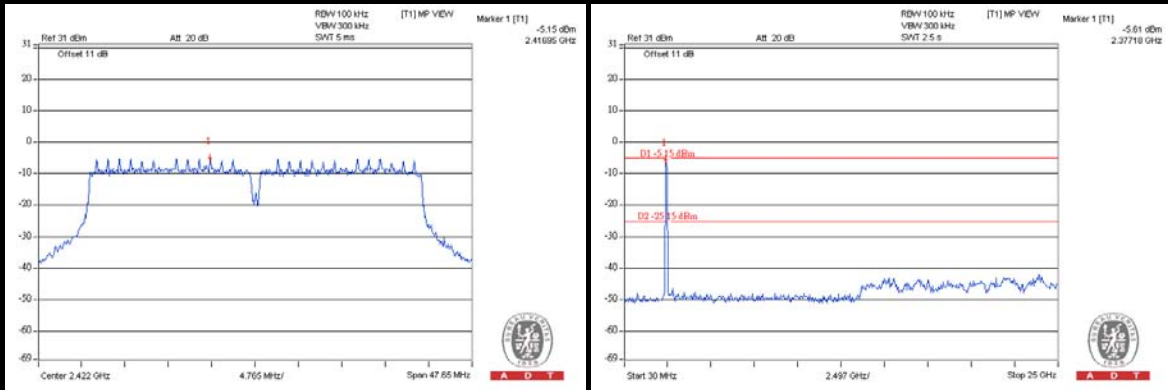

CH 4

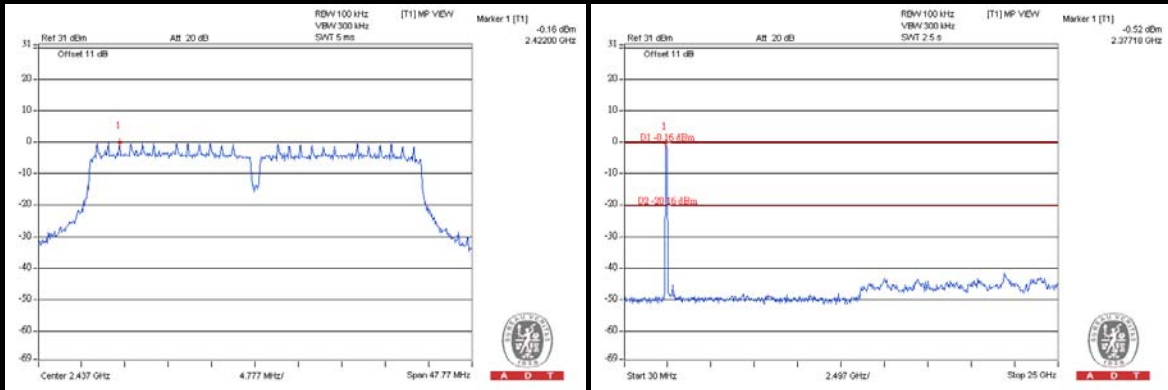

CH 7

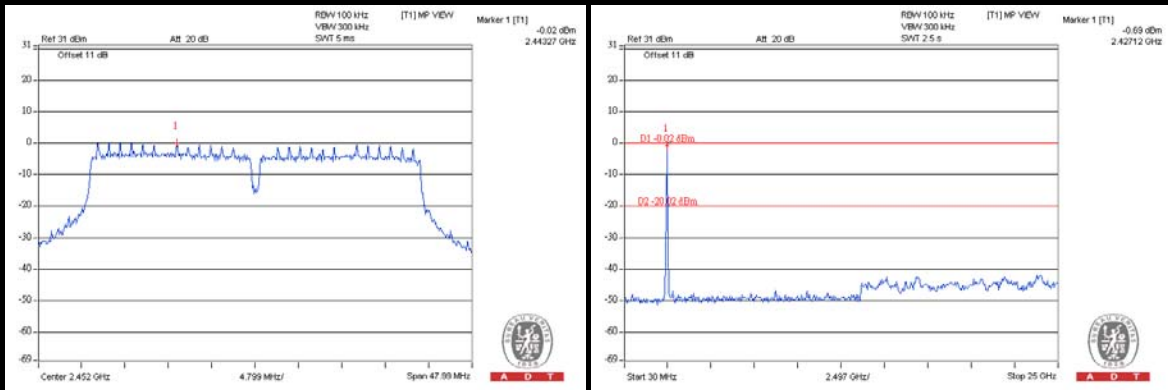

5. PHOTOGRAPHS OF THE TEST CONFIGURATION

Please refer to the attached file (Test Setup Photo).



6. INFORMATION ON THE TESTING LABORATORIES

We, Bureau Veritas Consumer Products Services (H.K.) Ltd., Taoyuan Branch, were founded in 1988 to provide our best service in EMC, Radio, Telecom and Safety consultation. Our laboratories are accredited and approved according to ISO/IEC 17025.

Copies of accreditation and authorization certificates of our laboratories obtained from approval agencies can be downloaded from our web site: www.adt.com.tw/index.5.phtml. If you have any comments, please feel free to contact us at the following:

Linko EMC/RF Lab:

Tel: 886-2-26052180
Fax: 886-2-26051924

Hsin Chu EMC/RF Lab:

Tel: 886-3-5935343
Fax: 886-3-5935342

Hwa Ya EMC/RF/Safety Telecom Lab:

Tel: 886-3-3183232
Fax: 886-3-3270892

Email: service.adt@tw.bureauveritas.com

Web Site: www.adt.com.tw

The address and road map of all our labs can be found in our web site also.



A D T

7. APPENDIX A - MODIFICATIONS RECORDERS FOR ENGINEERING CHANGES TO THE EUT BY THE LAB

No any modifications are made to the EUT by the lab during the test.

---END---