



A D T

FCC TEST REPORT

REPORT NO.: RF980810L04

MODEL NO.: DAP-1350

RECEIVED: Aug. 05, 2009

TESTED: Aug. 20 ~ Aug. 28, 2009

ISSUED: Sep. 03, 2009

APPLICANT: D-Link Corporation

ADDRESS: 17595 Mt. Herrmann, Fountain Valley, CA 92708,
U.S.A.

ISSUED BY: Bureau Veritas Consumer Products Services (H.K.)
Ltd., Taoyuan Branch

LAB ADDRESS: No. 47, 14th Ling, Chia Pau Tsuen, Lin Kou Hsiang,
Taipei Hsien 244, Taiwan, R.O.C.

TEST LOCATION: No. 19, Hwa Ya 2nd Rd, Wen Hwa Tsuen, Kwei
Shan Hsiang, Taoyuan Hsien 333, Taiwan, R.O.C.

This test report consists of 105 pages in total. It may be duplicated completely for legal use with the approval of the applicant. It should not be reproduced except in full, without the written approval of our laboratory. The client should not use it to claim product endorsement by TAF or any government agencies. The test results in the report only apply to the tested sample.





A D T

TABLE OF CONTENTS

1.	CERTIFICATION.....	4
2.	SUMMARY OF TEST RESULTS	5
2.1	MEASUREMENT UNCERTAINTY	5
3.	GENERAL INFORMATION	6
3.1	GENERAL DESCRIPTION OF EUT	6
3.2	DESCRIPTION OF TEST MODES	8
3.2.1	CONFIGURATION OF SYSTEM UNDER TEST	9
3.2.2	TEST MODE APPLICABILITY AND TESTED CHANNEL DETAIL	10
3.3	GENERAL DESCRIPTION OF APPLIED STANDARDS	12
3.4	DESCRIPTION OF SUPPORT UNITS	12
4.	TEST TYPES AND RESULTS	13
4.1	RADIATED EMISSION MEASUREMENT	13
4.1.1	LIMITS OF RADIATED EMISSION MEASUREMENT	13
4.1.2	TEST INSTRUMENTS.....	14
4.1.3	TEST PROCEDURES	15
4.1.4	DEVIATION FROM TEST STANDARD.....	15
4.1.5	TEST SETUP	16
4.1.6	EUT OPERATING CONDITIONS	16
4.1.7	TEST RESULTS	17
4.2	CONDUCTED EMISSION MEASUREMENT	33
4.2.1	LIMITS OF CONDUCTED EMISSION MEASUREMENT	33
4.2.2	TEST INSTRUMENTS.....	33
4.2.3	TEST PROCEDURES	34
4.2.4	DEVIATION FROM TEST STANDARD.....	34
4.2.5	TEST SETUP	35
4.2.6	EUT OPERATING CONDITIONS	35
4.2.7	TEST RESULTS	36
4.3	6dB BANDWIDTH MEASUREMENT	44
4.3.1	LIMITS OF 6dB BANDWIDTH MEASUREMENT	44
4.3.2	TEST INSTRUMENTS.....	44
4.3.3	TEST PROCEDURE.....	44
4.3.4	DEVIATION FROM TEST STANDARD.....	44
4.3.5	TEST SETUP	45
4.3.6	EUT OPERATING CONDITIONS	45
4.3.7	TEST RESULTS	46
4.4	MAXIMUM PEAK OUTPUT POWER.....	62



A D T

4.4.1	LIMITS OF MAXIMUM PEAK OUTPUT POWER MEASUREMENT	62
4.4.2	INSTRUMENTS	62
4.4.3	TEST PROCEDURES	62
4.4.4	DEVIATION FROM TEST STANDARD.....	63
4.4.5	TEST SETUP	63
4.4.6	EUT OPERATING CONDITIONS	63
4.4.7	TEST RESULTS	64
4.5	POWER SPECTRAL DENSITY MEASUREMENT	66
4.5.1	LIMITS OF POWER SPECTRAL DENSITY MEASUREMENT	66
4.5.2	TEST INSTRUMENTS.....	66
4.5.3	TEST PROCEDURE.....	66
4.5.4	DEVIATION FROM TEST STANDARD.....	67
4.5.5	TEST SETUP.....	67
4.5.6	EUT OPERATING CONDITION.....	67
4.5.7	TEST RESULTS	68
4.6	BAND EDGES MEASUREMENT	84
4.6.1	LIMITS OF BAND EDGES MEASUREMENT	84
4.6.2	TEST INSTRUMENTS.....	84
4.6.3	TEST PROCEDURE.....	85
4.6.4	DEVIATION FROM TEST STANDARD.....	85
4.6.5	EUT OPERATING CONDITION.....	85
4.6.6	TEST RESULTS	86
4.7	ANTENNA REQUIREMENT	102
4.7.1	STANDARD APPLICABLE	102
4.7.2	ANTENNA CONNECTED CONSTRUCTION	102
5.	PHOTOGRAPHS OF THE TEST CONFIGURATION.....	103
6.	INFORMATION ON THE TESTING LABORATORIES	104
7.	APPENDIX A - MODIFICATIONS RECORDERS FOR ENGINEERING CHANGES TO THE EUT BY THE LAB.....	105



A D T

1. CERTIFICATION

PRODUCT: Wireless N Pocket Router/Access Point
MODEL: DAP-1350
BRAND: D-Link
APPLICANT: D-Link Corporation
TEST SAMPLE: ENGINEERING SAMPLE
TESTED: Aug. 20 ~ Aug. 28, 2009
STANDARDS: **FCC Part 15, Subpart C (Section 15.247)**
ANSI C63.4-2003

The above equipment (Model: DAP-1350) has been tested by **Bureau Veritas Consumer Products Services (H.K.) Ltd., Taoyuan Branch**, and found compliance with the requirement of the above standards. The test record, data evaluation & Equipment Under Test (EUT) configurations represented herein are true and accurate accounts of the measurements of the sample's EMC characteristics under the conditions specified in this report.

PREPARED BY : Wendy Liao , **DATE:** Sep. 03, 2009
Wendy Liao / Senior Specialist

TECHNICAL ACCEPTANCE : Long Chen , **DATE:** Sep. 03, 2009
Responsible for RF
Long Chen / Senior Engineer

APPROVED BY : Gary Chang , **DATE:** Sep. 03, 2009
Gary Chang / Assistant Manager



2. SUMMARY OF TEST RESULTS

The EUT has been tested according to the following specifications:

APPLIED STANDARD: FCC PART 15, SUBPART C (SECTION 15.247)			
STANDARD SECTION	TEST TYPE AND LIMIT	RESULT	REMARK
15.207	AC Power Conducted Emission	PASS	Meet the requirement of limit. Minimum passing margin is -1.13dB at 0.608MHz.
15.247(a)(2)	Spectrum Bandwidth of a Direct Sequence Spread Spectrum System Limit: min. 500kHz	PASS	Meet the requirement of limit.
15.247(b)	Maximum Peak Output Power Limit: max. 30dBm	PASS	Meet the requirement of limit.
15.247(d)	Radiated Emissions Limit: Table 15.209	PASS	Meet the requirement of limit. Minimum passing margin is -1.08dB at 2483.50MHz
15.247(e)	Power Spectral Density Limit: max. 8dBm	PASS	Meet the requirement of limit.
15.247(d)	Band Edge Measurement Limit: 20dB less than the peak value of fundamental frequency	PASS	Meet the requirement of limit.

2.1 MEASUREMENT UNCERTAINTY

Where relevant, the following measurement uncertainty levels have been estimated for tests performed on the EUT as specified in CISPR 16-4-2:

MEASUREMENT	FREQUENCY	UNCERTAINTY
Conducted emissions	150kHz~30MHz	2.44 dB
Radiated emissions	30MHz ~ 200MHz	2.93 dB
	200MHz ~1000MHz	2.95 dB
	1GHz ~ 18GHz	2.26 dB
	18GHz ~ 40GHz	1.94 dB

This uncertainty represents an expanded uncertainty expressed at approximately the 95% confidence level using a coverage factor of $k = 2$.



3. GENERAL INFORMATION

3.1 GENERAL DESCRIPTION OF EUT

EUT	Wireless N Pocket Router/Access Point
MODEL NO.	DAP-1350
FCC ID	KA2AP1350A1
POWER SUPPLY	5 Vdc from adapter 5 Vdc from host equipment
MODULATION TYPE	CCK, DQPSK, DBPSK for DSSS 64QAM, 16QAM, QPSK, BPSK for OFDM
MODULATION TECHNOLOGY	DSSS, OFDM
TRANSFER RATE	802.11b:11.0/ 5.5/ 2.0/ 1.0Mbps 802.11g: 54.0/ 48.0/ 36.0/ 24.0/ 18.0/ 12.0/ 9.0/ 6.0Mbps Draft 802.11n: up to 300.0Mbps
OPERATING FREQUENCY	2412.0 ~ 2462.0MHz
NUMBER OF CHANNEL	11 for 802.11b, 802.11g, draft 802.11n (20MHz) 7 for draft 802.11n (40MHz)
OUTPUT POWER	491.51mW
ANTENNA TYPE	PIFA antenna with 3dBi gain
DATA CABLE	0.45 non-shielded USB cable without core
I/O PORTS	RJ45, USB
ACCESSORY DEVICES	Adapter

NOTE:

1. The EUT incorporates a MIMO function. Physically, the EUT provides two completed transmitters and two receivers.

MODULATION MODE	TX FUNCTION
802.11b	2TX
802.11g	2TX
Draft 802.11n (20MHz)	2TX
Draft 802.11n (40MHz)	2TX

2. The EUT uses following adapters.

ADAPTER 1	
BRAND	D-Link
MODEL	CF1505-B IW
INPUT POWER	100-120Vac, 0.4A, 50-60Hz
OUTPUT POWER	+5Vdc, 2.5A
POEWR LINE	1.8 m non-shielded cable without core



A D T

ADAPTER 2	
BRAND	AMIGO
MODEL	AMS3-0502500SU
INPUT POWER	100-120Vac ~60Hz, 0.5A
OUTPUT POWER	5Vdc, 2.5A
POEWR LINE	1.8 m non-shielded cable without core

ADAPTER 3	
BRAND	D-Link
MODEL	CF1505-B
INPUT POWER	100-240Vac, ~0.4A , 50-60Hz
OUTPUT POWER	5Vdc, 2.5A
POEWR LINE	1.8 m non-shielded cable without core

3. The above EUT information was declared by manufacturer and for more detailed features description, please refer to the manufacturer's specifications or user's manual.



3.2 DESCRIPTION OF TEST MODES

11 channels are provided for 802.11b, 802.11g and draft 802.11n (20MHz):

CHANNEL	FREQUENCY	CHANNEL	FREQUENCY
1	2412MHz	7	2442MHz
2	2417MHz	8	2447MHz
3	2422MHz	9	2452MHz
4	2427MHz	10	2457MHz
5	2432MHz	11	2462MHz
6	2437MHz		

7 channels are provided for draft 802.11n (40MHz):

CHANNEL	FREQUENCY	CHANNEL	FREQUENCY
1	2422MHz	5	2442MHz
2	2427MHz	6	2447MHz
3	2432MHz	7	2452MHz
4	2437MHz		

3.2.1 CONFIGURATION OF SYSTEM UNDER TEST

TEST MODE A, B, D

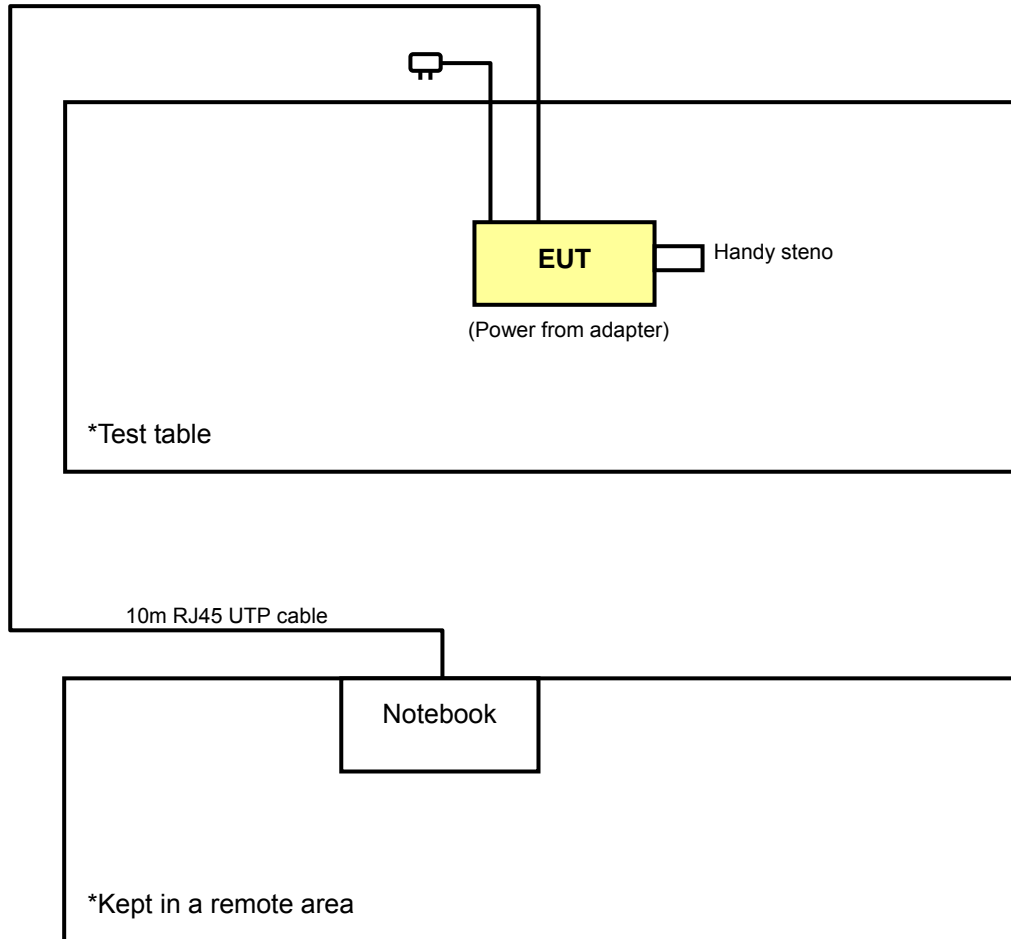

TEST MODE C

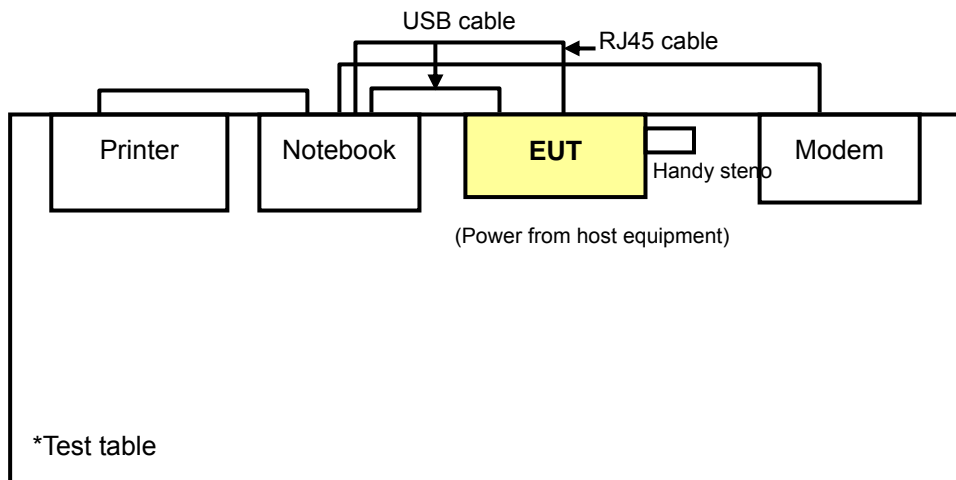



3.2.2 TEST MODE APPLICABILITY AND TESTED CHANNEL DETAIL

EUT CONFIGURE MODE	APPLICABLE TO				DESCRIPTION
	RE≥1G	RE<1G	PLC	APCM	
A	√	√	√	√	EUT tested with adapter1: (CF1505-B IW)
B	-	√	√	-	EUT tested with adapter2: (AMS3-0502500SU)
C	-	√	√	-	EUT tested with USB cable
D	-	√	√	-	EUT tested with adapter3: (CF1505-B)

Where **RE≥1G**: Radiated Emission above 1GHz **RE<1G**: Radiated Emission below 1GHz
PLC: Power Line Conducted Emission **APCM**: Antenna Port Conducted Measurement

NOTE: “-” means no effect

RADIATED EMISSION TEST (ABOVE 1GHz):

- Pre-Scan has been conducted to determine the worst-case mode from all possible combinations between available modulations, data rates, XYZ axis and antenna ports (if EUT with antenna diversity architecture).
- Following channel(s) was (were) selected for the final test as listed below.

EUT CONFIGURE MODE	MODE	AVAILABLE CHANNEL	TESTED CHANNEL	MODULATION TECHNOLOGY	MODULATION TYPE	DATA RATE (Mbps)	AXIS
A	802.11b	1 to 11	1, 6, 11	DSSS	DBPSK	1.0	X
	802.11g	1 to 11	1, 6, 11	OFDM	BPSK	6.0	
	Draft 802.11n (20MHz)	1 to 11	1, 6, 11	OFDM	BPSK	7.2	
	Draft 802.11n (40MHz)	1 to 7	1, 4, 7	OFDM	BPSK	15.0	

RADIATED EMISSION TEST (BELOW 1GHz):

- Pre-Scan has been conducted to determine the worst-case mode from all possible combinations between available modulations, data rates, XYZ axis and antenna ports (if EUT with antenna diversity architecture).
- Following channel(s) was (were) selected for the final test as listed below.

EUT CONFIGURE MODE	MODE	AVAILABLE CHANNEL	TESTED CHANNEL	MODULATION TECHNOLOGY	MODULATION TYPE	DATA RATE (Mbps)	AXIS
A, B, C, D	802.11g	1 to 11	6	OFDM	BPSK	6.0	X

POWER LINE CONDUCTED EMISSION TEST:

- Pre-Scan has been conducted to determine the worst-case mode from all possible combinations between available modulations, data rates and antenna ports (if EUT with antenna diversity architecture).
- Following channel(s) was (were) selected for the final test as listed below.

EUT CONFIGURE MODE	MODE	AVAILABLE CHANNEL	TESTED CHANNEL	MODULATION TECHNOLOGY	MODULATION TYPE	DATA RATE (Mbps)
A, B, C, D	802.11g	1 to 11	6	OFDM	BPSK	6.0



A D T

BANDEDGE MEASUREMENT:

- Pre-Scan has been conducted to determine the worst-case mode from all possible combinations between available modulations, data rates and antenna ports (if EUT with antenna diversity architecture).
- Following channel(s) was (were) selected for the final test as listed below.

EUT CONFIGURE MODE	MODE	AVAILABLE CHANNEL	TESTED CHANNEL	MODULATION TECHNOLOGY	MODULATION TYPE	DATA RATE (Mbps)
A	802.11b	1 to 11	1, 11	DSSS	DBPSK	1.0
	802.11g	1 to 11	1, 11	OFDM	BPSK	6.0
	Draft 802.11n (20MHz)	1 to 11	1, 11	OFDM	BPSK	7.2
	Draft 802.11n (40MHz)	1 to 7	1, 7	OFDM	BPSK	15.0

ANTENNA PORT CONDUCTED MEASUREMENT:

- Pre-Scan has been conducted to determine the worst-case mode from all possible combinations between available modulations, data rates and antenna ports (if EUT with antenna diversity architecture).
- Following channel(s) was (were) selected for the final test as listed below.

EUT CONFIGURE MODE	MODE	AVAILABLE CHANNEL	TESTED CHANNEL	MODULATION TECHNOLOGY	MODULATION TYPE	DATA RATE (Mbps)
A	802.11b	1 to 11	1, 6, 11	DSSS	DBPSK	1.0
	802.11g	1 to 11	1, 6, 11	OFDM	BPSK	6.0
	Draft 802.11n (20MHz)	1 to 11	1, 6, 11	OFDM	BPSK	7.2
	Draft 802.11n (40MHz)	1 to 7	1, 4, 7	OFDM	BPSK	15.0



A D T

3.3 GENERAL DESCRIPTION OF APPLIED STANDARDS

The EUT is a RF Product. According to the specifications of the manufacturer, it must comply with the requirements of the following standards:

FCC Part 15, Subpart C (15.247)

ANSI C63.4-2003

All test items have been performed and recorded as per the above standards.

NOTE: The EUT is also considered as a kind of computer peripheral, because the connection to computer is necessary for typical use. It has been verified to comply with the requirements of FCC Part 15, Subpart B, Class B (DoC). The test report has been issued separately.

3.4 DESCRIPTION OF SUPPORT UNITS

The EUT has been tested as an independent unit together with other necessary accessories or support units. The following support units or accessories were used to form a representative test configuration during the tests.

NO.	PRODUCT	BRAND	MODEL NO.	SERIAL NO.	FCC ID
1	NOTEBOOK COMPUTER	DELL	PP05L	16484462992	E2K24CLNS
2	PRINTER	EPSON	LQ-300+	DCGY054011	FCC DoC Approved
3	MODEM	ACEEX	1414V/3	0401008253	IFAXDM1414
4	HANDY STENO	Apacer	AH123	NA	NA

NO.	SIGNAL CABLE DESCRIPTION OF THE ABOVE SUPPORT UNITS
1	10 m non-shielded RJ45 cable
2	1.8m braid shielded wire, DB25 connector, w/o core.
3	1.2m braid shielded wire, DB25 & DB9 connector, w/o core.
4	NA

NOTE:

1. All power cords of the above support units are non shielded (1.8m).
2. Items 1 acted as a communication partner to transfer data in test modes A, B, D.
3. Item 4 is provided by the client.



A D T

4. TEST TYPES AND RESULTS

4.1 RADIATED EMISSION MEASUREMENT

4.1.1 LIMITS OF RADIATED EMISSION MEASUREMENT

Emissions radiated outside of the specified bands, shall be according to the general radiated limits in 15.209 as following:

FREQUENCIES (MHz)	FIELD STRENGTH (microvolts/meter)	MEASUREMENT DISTANCE (meters)
0.009 ~ 0.490	2400/F(kHz)	300
0.490 ~ 1.705	24000/F(kHz)	30
1.705 ~ 30.0	30	30
30 ~ 88	100	3
88 ~ 216	150	3
216 ~ 960	200	3
Above 960	500	3

NOTE:

1. The lower limit shall apply at the transition frequencies.
2. Emission level (dBuV/m) = 20 log Emission level (uV/m).
3. As shown in 15.35(b), for frequencies above 1000MHz, the field strength limits are based on average detector, however, the peak field strength of any emission shall not exceed the maximum permitted average limits, specified above by more than 20dB under any condition of modulation.



A D T

4.1.2 TEST INSTRUMENTS

DESCRIPTION & MANUFACTURER	MODEL NO.	SERIAL NO.	DATE OF CALIBRATION	DUE DATE OF CALIBRATION
Test Receiver ROHDE & SCHWARZ	ESIB7	100212	May 25, 2009	May 24, 2010
Spectrum Analyzer ROHDE & SCHWARZ	FSP40	100040	Jul. 07, 2009	Jul. 06, 2010
BILOG Antenna SCHWARZBECK	VULB9168	9168-156	Apr. 30, 2009	Apr. 29, 2010
HORN Antenna SCHWARZBECK	BBHA 9120 D	9120D-563	Aug. 10, 2009	Aug. 09, 2010
HORN Antenna SCHWARZBECK	BBHA 9170	BBHA9170242	Jan. 06, 2009	Jan. 05, 2010
Preamplifier Agilent	8449B	3008A01911	Sep. 10, 2008	Sep. 09, 2009
Preamplifier Agilent	8447D	2944A10638	Dec. 26, 2008	Dec. 25, 2009
RF signal cable HUBER+SUHNNER	SUCOFLEX 104	218190/4 231241/4	May 13, 2009	May 12, 2010
RF signal cable Worken	8D-FB	Cable-HYCH9-01	Aug. 17, 2009	Aug. 16, 2010
Software	ADT_Radiated_ V7.6.15.9.2	NA	NA	NA
Antenna Tower EMCO	2070/2080	512.835.4684	NA	NA
Turn Table EMCO	2087-2.03	NA	NA	NA
Antenna Tower & Turn Table Controller EMCO	2090	NA	NA	NA

- NOTE:**
1. The calibration interval of the above test instruments is 12 months and the calibrations are traceable to NML/ROC and NIST/USA.
 2. The test was performed in HwaYa Chamber 9.
 3. The horn antenna and HP preamplifier (model: 8449B) are used only for the measurement of emission frequency above 1GHz if tested.
 4. The FCC Site Registration No. is 460141.
 5. The IC Site Registration No. is IC 7450F-4.



4.1.3 TEST PROCEDURES

- a. The EUT was placed on the top of a rotating table 0.8 meters above the ground at a 3 meters semi-anechoic chamber. The table was rotated 360 degrees to determine the position of the highest radiation.
- b. The EUT was set 3 meters away from the interference-receiving antenna, which was mounted on the top of a variable-height antenna tower.
- c. The antenna is a broadband antenna, and its height is varied from one meter to four meters above the ground to determine the maximum value of the field strength. Both horizontal and vertical polarizations of the antenna are set to make the measurement.
- d. For each suspected emission, the EUT was arranged to its worst case and then the antenna was tuned to heights from 1 meter to 4 meters and the rotatable table was turned from 0 degrees to 360 degrees to find the maximum reading.
- e. The test-receiver system was set to Peak Detect Function and Specified Bandwidth with Maximum Hold Mode.
- f. If the emission level of the EUT in peak mode was lower than the limit specified, then testing could be stopped and the peak values of the EUT would be reported. Otherwise the emissions would be re-tested one by one using peak, quasi-peak or average method as specified and then reported in a data sheet.

NOTE:

1. The resolution bandwidth and video bandwidth of test receiver/spectrum analyzer is 120kHz for Quasi-peak detection at frequency below 1GHz.
2. The resolution bandwidth of test receiver/spectrum analyzer is 1MHz and video bandwidth is 3MHz for Peak detection at frequency above 1GHz.
3. The resolution bandwidth of test receiver/spectrum analyzer is 1MHz and the video bandwidth is 10Hz for Average detection (AV) at frequency above 1GHz.
4. All modes of operation were investigated and the worst-case emissions are reported.

4.1.4 DEVIATION FROM TEST STANDARD

No deviation.

4.1.5 TEST SETUP

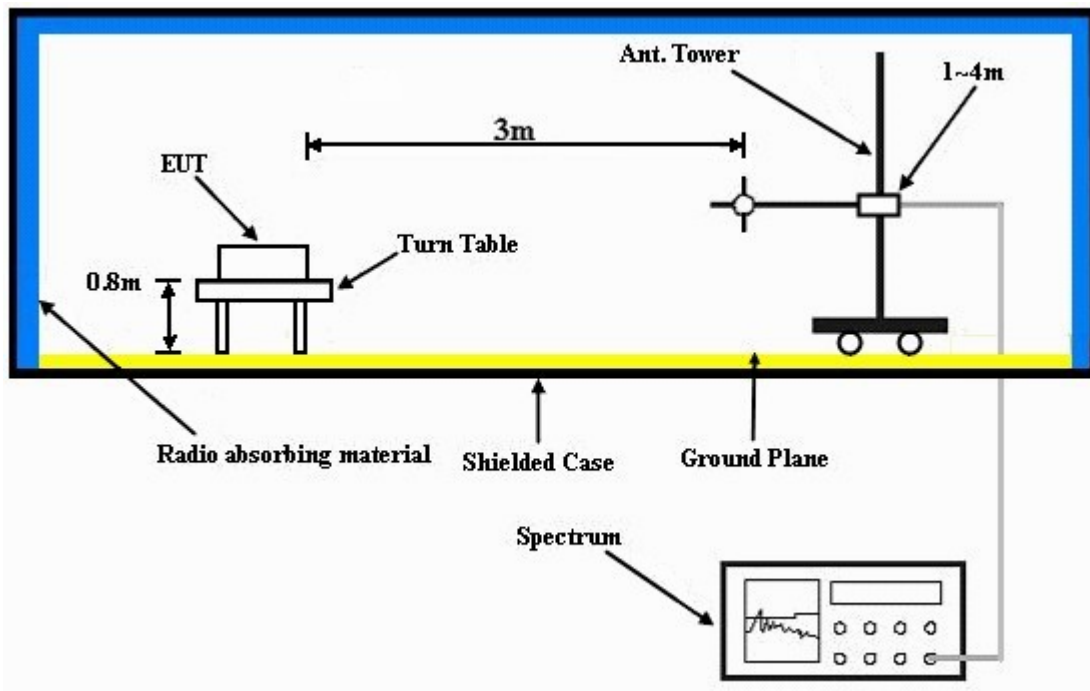

For the actual test configuration, please refer to the attached file (Test Setup Photo).

4.1.6 EUT OPERATING CONDITIONS

TEST MODE A, B, D

- Plugged the Handy Steno in the EUT and place the EUT on the testing table.
- Prepared the notebook system outside of testing area to act as communication partner.
- The communication partners connected with EUT via a RJ45 cable and run a test program (provided by manufacturer) to enable EUT under transmission condition continuously at specific channel frequency.
- The communication partner sent data to EUT by command "PING".

TEST MODE C

- Plugged the Handy Steno in the EUT and place the EUT on the testing table.
- The notebook system ran a test program (provided by manufacturer) to enable EUT under transmission condition continuously at specific channel frequency.
- The necessary accessories enable the system in full functions.



A D T

4.1.7 TEST RESULTS

802.11b DSSS MODULATION

EUT TEST CONDITION		MEASUREMENT DETAIL	
CHANNEL	Channel 1	FREQUENCY RANGE	1 ~ 25GHz
INPUT POWER (SYSTEM)	120Vac, 60 Hz	DETECTOR FUNCTION	Peak (PK) Average (AV)
ENVIRONMENTAL CONDITIONS	24deg. C, 64%RH 1000 hPa	TESTED BY	Lori Chiu

ANTENNA POLARITY & TEST DISTANCE: HORIZONTAL AT 3 M								
NO.	FREQ. (MHz)	EMISSION LEVEL (dBuV/m)	LIMIT (dBuV/m)	MARGIN (dB)	ANTENNA HEIGHT (m)	TABLE ANGLE (Degree)	RAW VALUE (dBuV)	CORRECTION FACTOR (dB/m)
1	2386.00	62.77 PK	74.00	-11.23	1.33 H	281	30.56	32.21
2	2386.00	52.42 AV	54.00	-1.58	1.33 H	281	20.21	32.21
3	*2412.00	109.04 PK			1.33 H	281	76.74	32.30
4	*2412.00	105.08 AV			1.33 H	281	72.78	32.30
5	2489.00	61.75 PK	74.00	-12.25	1.37 H	280	29.17	32.58
6	2489.00	51.40 AV	54.00	-2.60	1.37 H	280	18.82	32.58
7	4824.00	48.26 PK	74.00	-25.74	1.31 H	121	9.93	38.33
8	4824.00	36.31 AV	54.00	-17.69	1.31 H	121	-2.02	38.33
ANTENNA POLARITY & TEST DISTANCE: VERTICAL AT 3 M								
NO.	FREQ. (MHz)	EMISSION LEVEL (dBuV/m)	LIMIT (dBuV/m)	MARGIN (dB)	ANTENNA HEIGHT (m)	TABLE ANGLE (Degree)	RAW VALUE (dBuV)	CORRECTION FACTOR (dB/m)
1	2386.00	57.94 PK	74.00	-16.06	1.00 V	169	25.73	32.21
2	2386.00	47.36 AV	54.00	-6.64	1.00 V	169	15.15	32.21
3	*2412.00	101.88 PK			1.00 V	169	69.58	32.30
4	*2412.00	97.63 AV			1.00 V	169	65.33	32.30
5	2489.00	58.55 PK	74.00	-15.45	1.00 V	169	25.97	32.58
6	2489.00	48.09 AV	54.00	-5.91	1.00 V	169	15.51	32.58
7	4824.00	48.95 PK	74.00	-25.05	1.00 V	234	10.62	38.33
8	4824.00	37.14 AV	54.00	-16.86	1.00 V	234	-1.19	38.33

- REMARKS:**
1. Emission level (dBuV/m) = Raw Value (dBuV) + Correction Factor (dB/m).
 2. Correction Factor (dB/m) = Antenna Factor (dB/m) + Cable Factor (dB).
 3. The other emission levels were very low against the limit.
 4. Margin value = Emission level – Limit value.
 5. “ * “: Fundamental frequency.



A D T

EUT TEST CONDITION		MEASUREMENT DETAIL	
CHANNEL	Channel 6	FREQUENCY RANGE	1 ~ 25GHz
INPUT POWER (SYSTEM)	120Vac, 60 Hz	DETECTOR FUNCTION	Peak (PK) Average (AV)
ENVIRONMENTAL CONDITIONS	24deg. C, 64%RH 1000 hPa	TESTED BY	Lori Chiu

ANTENNA POLARITY & TEST DISTANCE: HORIZONTAL AT 3 M								
NO.	FREQ. (MHz)	EMISSION LEVEL (dBuV/m)	LIMIT (dBuV/m)	MARGIN (dB)	ANTENNA HEIGHT (m)	TABLE ANGLE (Degree)	RAW VALUE (dBuV)	CORRECTION FACTOR (dB/m)
1	*2437.00	109.20 PK			1.33 H	281	76.81	32.39
2	*2437.00	105.33 AV			1.33 H	281	72.94	32.39
3	4874.00	49.35 PK	74.00	-24.65	1.00 H	284	10.94	38.41
4	4874.00	36.72 AV	54.00	-17.28	1.00 H	284	-1.69	38.41
ANTENNA POLARITY & TEST DISTANCE: VERTICAL AT 3 M								
NO.	FREQ. (MHz)	EMISSION LEVEL (dBuV/m)	LIMIT (dBuV/m)	MARGIN (dB)	ANTENNA HEIGHT (m)	TABLE ANGLE (Degree)	RAW VALUE (dBuV)	CORRECTION FACTOR (dB/m)
1	*2437.00	102.05 PK			1.00 V	171	69.66	32.39
2	*2437.00	97.81 AV			1.00 V	171	65.42	32.39
3	4874.00	49.54 PK	74.00	-24.46	1.00 V	182	11.13	38.41
4	4874.00	37.77 AV	54.00	-16.23	1.00 V	182	-0.64	38.41

- REMARKS:**
1. Emission level (dBuV/m) = Raw Value (dBuV) + Correction Factor (dB/m).
 2. Correction Factor (dB/m) = Antenna Factor (dB/m) + Cable Factor (dB).
 3. The other emission levels were very low against the limit.
 4. Margin value = Emission level – Limit value.
 5. “ * “: Fundamental frequency.



A D T

EUT TEST CONDITION		MEASUREMENT DETAIL	
CHANNEL	Channel 11	FREQUENCY RANGE	1 ~ 25GHz
INPUT POWER (SYSTEM)	120Vac, 60 Hz	DETECTOR FUNCTION	Peak (PK) Average (AV)
ENVIRONMENTAL CONDITIONS	24deg. C, 64%RH 1000 hPa	TESTED BY	Lori Chiu

ANTENNA POLARITY & TEST DISTANCE: HORIZONTAL AT 3 M								
NO.	FREQ. (MHz)	EMISSION LEVEL (dBuV/m)	LIMIT (dBuV/m)	MARGIN (dB)	ANTENNA HEIGHT (m)	TABLE ANGLE (Degree)	RAW VALUE (dBuV)	CORRECTION FACTOR (dB/m)
1	*2462.00	108.87 PK			1.29 H	278	76.39	32.48
2	*2462.00	104.84 AV			1.29 H	278	72.36	32.48
3	2483.50	61.71 PK	74.00	-12.29	1.29 H	278	29.15	32.56
4	2483.50	51.55 AV	54.00	-2.45	1.29 H	278	18.99	32.56
5	4924.00	49.54 PK	74.00	-24.46	1.04 H	164	11.02	38.51
6	4924.00	38.33 AV	54.00	-15.67	1.04 H	164	-0.19	38.51
ANTENNA POLARITY & TEST DISTANCE: VERTICAL AT 3 M								
NO.	FREQ. (MHz)	EMISSION LEVEL (dBuV/m)	LIMIT (dBuV/m)	MARGIN (dB)	ANTENNA HEIGHT (m)	TABLE ANGLE (Degree)	RAW VALUE (dBuV)	CORRECTION FACTOR (dB/m)
1	*2462.00	101.78 PK			1.02 V	95	69.30	32.48
2	*2462.00	97.46 AV			1.02 V	95	64.98	32.48
3	2483.50	58.63 PK	74.00	-15.37	1.02 V	95	26.07	32.56
4	2483.50	47.55 AV	54.00	-6.45	1.02 V	95	14.99	32.56
5	4924.00	50.53 PK	74.00	-23.47	1.00 V	357	12.01	38.51
6	4924.00	39.44 AV	54.00	-14.56	1.00 V	357	0.92	38.51

- REMARKS:**
1. Emission level (dBuV/m) = Raw Value (dBuV) + Correction Factor (dB/m).
 2. Correction Factor (dB/m) = Antenna Factor (dB/m) + Cable Factor (dB).
 3. The other emission levels were very low against the limit.
 4. Margin value = Emission level – Limit value.
 5. “ * “: Fundamental frequency.



A D T

802.11g OFDM MODULATION

EUT TEST CONDITION		MEASUREMENT DETAIL	
CHANNEL	Channel 1	FREQUENCY RANGE	1 ~ 25GHz
INPUT POWER (SYSTEM)	120Vac, 60 Hz	DETECTOR FUNCTION	Peak (PK) Average (AV)
ENVIRONMENTAL CONDITIONS	24deg. C, 64%RH 1000 hPa	TESTED BY	Lori Chiu

ANTENNA POLARITY & TEST DISTANCE: HORIZONTAL AT 3 M								
NO.	FREQ. (MHz)	EMISSION LEVEL (dBuV/m)	LIMIT (dBuV/m)	MARGIN (dB)	ANTENNA HEIGHT (m)	TABLE ANGLE (Degree)	RAW VALUE (dBuV)	CORRECTION FACTOR (dB/m)
1	2390.00	62.10 PK	74.00	-11.90	1.34 H	281	29.88	32.22
2	2390.00	49.86 AV	54.00	-4.14	1.34 H	281	17.64	32.22
3	*2412.00	108.78 PK			1.33 H	279	76.48	32.30
4	*2412.00	98.41 AV			1.33 H	279	66.11	32.30
5	4824.00	47.42 PK	74.00	-26.58	1.00 H	217	9.09	38.33
6	4824.00	34.87 AV	54.00	-19.13	1.00 H	217	-3.46	38.33
ANTENNA POLARITY & TEST DISTANCE: VERTICAL AT 3 M								
NO.	FREQ. (MHz)	EMISSION LEVEL (dBuV/m)	LIMIT (dBuV/m)	MARGIN (dB)	ANTENNA HEIGHT (m)	TABLE ANGLE (Degree)	RAW VALUE (dBuV)	CORRECTION FACTOR (dB/m)
1	2390.00	58.45 PK	74.00	-15.55	1.00 V	278	26.23	32.22
2	2390.00	46.97 AV	54.00	-7.03	1.00 V	278	14.75	32.22
3	*2412.00	100.81 PK			1.00 V	278	68.51	32.30
4	*2412.00	90.50 AV			1.00 V	278	58.20	32.30
5	4824.00	47.86 PK	74.00	-26.14	1.00 V	116	9.53	38.33
6	4824.00	35.14 AV	54.00	-18.86	1.00 V	116	-3.19	38.33

- REMARKS:**
1. Emission level (dBuV/m) = Raw Value (dBuV) + Correction Factor (dB/m).
 2. Correction Factor (dB/m) = Antenna Factor (dB/m) + Cable Factor (dB).
 3. The other emission levels were very low against the limit.
 4. Margin value = Emission level – Limit value.
 5. “ * “: Fundamental frequency.



A D T

EUT TEST CONDITION		MEASUREMENT DETAIL	
CHANNEL	Channel 6	FREQUENCY RANGE	1 ~ 25GHz
INPUT POWER (SYSTEM)	120Vac, 60 Hz	DETECTOR FUNCTION	Peak (PK) Average (AV)
ENVIRONMENTAL CONDITIONS	24deg. C, 64%RH 1000 hPa	TESTED BY	Lori Chiu

ANTENNA POLARITY & TEST DISTANCE: HORIZONTAL AT 3 M								
NO.	FREQ. (MHz)	EMISSION LEVEL (dBuV/m)	LIMIT (dBuV/m)	MARGIN (dB)	ANTENNA HEIGHT (m)	TABLE ANGLE (Degree)	RAW VALUE (dBuV)	CORRECTION FACTOR (dB/m)
1	*2437.00	108.89 PK			1.34 H	280	76.50	32.39
2	*2437.00	98.67 AV			1.34 H	280	66.28	32.39
3	4874.00	47.91 PK	74.00	-26.09	1.00 H	223	9.50	38.41
4	4874.00	35.34 AV	54.00	-18.66	1.00 H	223	-3.07	38.41
ANTENNA POLARITY & TEST DISTANCE: VERTICAL AT 3 M								
NO.	FREQ. (MHz)	EMISSION LEVEL (dBuV/m)	LIMIT (dBuV/m)	MARGIN (dB)	ANTENNA HEIGHT (m)	TABLE ANGLE (Degree)	RAW VALUE (dBuV)	CORRECTION FACTOR (dB/m)
1	*2437.00	100.93 PK			1.00 V	283	68.54	32.39
2	*2437.00	90.72 AV			1.00 V	283	58.33	32.39
3	4874.00	48.25 PK	74.00	-25.75	1.00 V	221	9.84	38.41
4	4874.00	35.69 AV	54.00	-18.31	1.00 V	221	-2.72	38.41

- REMARKS:**
1. Emission level (dBuV/m) = Raw Value (dBuV) + Correction Factor (dB/m).
 2. Correction Factor (dB/m) = Antenna Factor (dB/m) + Cable Factor (dB).
 3. The other emission levels were very low against the limit.
 4. Margin value = Emission level – Limit value.
 5. “ * “: Fundamental frequency.



A D T

EUT TEST CONDITION		MEASUREMENT DETAIL	
CHANNEL	Channel 11	FREQUENCY RANGE	1 ~ 25GHz
INPUT POWER (SYSTEM)	120Vac, 60 Hz	DETECTOR FUNCTION	Peak (PK) Average (AV)
ENVIRONMENTAL CONDITIONS	24deg. C, 64%RH 1000 hPa	TESTED BY	Lori Chiu

ANTENNA POLARITY & TEST DISTANCE: HORIZONTAL AT 3 M								
NO.	FREQ. (MHz)	EMISSION LEVEL (dBuV/m)	LIMIT (dBuV/m)	MARGIN (dB)	ANTENNA HEIGHT (m)	TABLE ANGLE (Degree)	RAW VALUE (dBuV)	CORRECTION FACTOR (dB/m)
1	*2462.00	108.51 PK			1.33 H	278	76.03	32.48
2	*2462.00	98.18 AV			1.33 H	278	65.70	32.48
3	2483.50	64.53 PK	74.00	-9.47	1.32 H	280	31.97	32.56
4	2483.50	50.98 AV	54.00	-3.02	1.32 H	280	18.42	32.56
5	4924.00	47.85 PK	74.00	-26.15	1.00 H	205	9.34	38.51
6	4924.00	35.26 AV	54.00	-18.74	1.00 H	205	-3.25	38.51
ANTENNA POLARITY & TEST DISTANCE: VERTICAL AT 3 M								
NO.	FREQ. (MHz)	EMISSION LEVEL (dBuV/m)	LIMIT (dBuV/m)	MARGIN (dB)	ANTENNA HEIGHT (m)	TABLE ANGLE (Degree)	RAW VALUE (dBuV)	CORRECTION FACTOR (dB/m)
1	*2462.00	100.56 PK			1.03 V	96	68.08	32.48
2	*2462.00	90.21 AV			1.03 V	96	57.73	32.48
3	2483.50	59.52 PK	74.00	-14.48	1.03 V	96	26.96	32.56
4	2483.50	47.76 AV	54.00	-6.24	1.03 V	96	15.20	32.56
5	4924.00	48.11 PK	74.00	-25.89	1.00 V	124	9.60	38.51
6	4924.00	35.52 AV	54.00	-18.48	1.00 V	124	-2.99	38.51

- REMARKS:**
1. Emission level (dBuV/m) = Raw Value (dBuV) + Correction Factor (dB/m).
 2. Correction Factor (dB/m) = Antenna Factor (dB/m) + Cable Factor (dB).
 3. The other emission levels were very low against the limit.
 4. Margin value = Emission level – Limit value.
 5. “ * “: Fundamental frequency.



A D T

DRAFT 802.11n (20MHz) OFDM MODULATION

EUT TEST CONDITION		MEASUREMENT DETAIL	
CHANNEL	Channel 1	FREQUENCY RANGE	1 ~ 25GHz
INPUT POWER (SYSTEM)	120Vac, 60 Hz	DETECTOR FUNCTION	Peak (PK) Average (AV)
ENVIRONMENTAL CONDITIONS	24deg. C, 64%RH 1000 hPa	TESTED BY	Lori Chiu

ANTENNA POLARITY & TEST DISTANCE: HORIZONTAL AT 3 M								
NO.	FREQ. (MHz)	EMISSION LEVEL (dBuV/m)	LIMIT (dBuV/m)	MARGIN (dB)	ANTENNA HEIGHT (m)	TABLE ANGLE (Degree)	RAW VALUE (dBuV)	CORRECTION FACTOR (dB/m)
1	2390.00	64.00 PK	74.00	-10.00	1.35 H	281	31.78	32.22
2	2390.00	50.56 AV	54.00	-3.44	1.35 H	281	18.34	32.22
3	*2412.00	109.64 PK			1.35 H	281	77.34	32.30
4	*2412.00	99.55 AV			1.35 H	281	67.25	32.30
5	4824.00	47.67 PK	74.00	-26.33	1.00 H	196	9.34	38.33
6	4824.00	35.08 AV	54.00	-18.92	1.00 H	196	-3.25	38.33
ANTENNA POLARITY & TEST DISTANCE: VERTICAL AT 3 M								
NO.	FREQ. (MHz)	EMISSION LEVEL (dBuV/m)	LIMIT (dBuV/m)	MARGIN (dB)	ANTENNA HEIGHT (m)	TABLE ANGLE (Degree)	RAW VALUE (dBuV)	CORRECTION FACTOR (dB/m)
1	2390.00	59.54 PK	74.00	-14.46	1.05 V	95	27.32	32.22
2	2390.00	48.03 AV	54.00	-5.97	1.05 V	95	15.81	32.22
3	*2412.00	101.57 PK			1.05 V	95	69.27	32.30
4	*2412.00	91.22 AV			1.05 V	95	58.92	32.30
5	4824.00	48.14 PK	74.00	-25.86	1.00 V	121	9.81	38.33
6	4824.00	35.38 AV	54.00	-18.62	1.00 V	121	-2.95	38.33

- REMARKS:**
1. Emission level (dBuV/m) = Raw Value (dBuV) + Correction Factor (dB/m).
 2. Correction Factor (dB/m) = Antenna Factor (dB/m) + Cable Factor (dB).
 3. The other emission levels were very low against the limit.
 4. Margin value = Emission level – Limit value.
 5. “ * “: Fundamental frequency.



A D T

EUT TEST CONDITION		MEASUREMENT DETAIL	
CHANNEL	Channel 6	FREQUENCY RANGE	1 ~ 25GHz
INPUT POWER (SYSTEM)	120Vac, 60 Hz	DETECTOR FUNCTION	Peak (PK) Average (AV)
ENVIRONMENTAL CONDITIONS	24deg. C, 64%RH 1000 hPa	TESTED BY	Lori Chiu

ANTENNA POLARITY & TEST DISTANCE: HORIZONTAL AT 3 M								
NO.	FREQ. (MHz)	EMISSION LEVEL (dBuV/m)	LIMIT (dBuV/m)	MARGIN (dB)	ANTENNA HEIGHT (m)	TABLE ANGLE (Degree)	RAW VALUE (dBuV)	CORRECTION FACTOR (dB/m)
1	*2437.00	109.84 PK			1.33 H	280	77.45	32.39
2	*2437.00	99.72 AV			1.33 H	280	67.33	32.39
3	4874.00	48.03 PK	74.00	-25.97	1.00 H	215	9.62	38.41
4	4874.00	35.39 AV	54.00	-18.61	1.00 H	215	-3.02	38.41
ANTENNA POLARITY & TEST DISTANCE: VERTICAL AT 3 M								
NO.	FREQ. (MHz)	EMISSION LEVEL (dBuV/m)	LIMIT (dBuV/m)	MARGIN (dB)	ANTENNA HEIGHT (m)	TABLE ANGLE (Degree)	RAW VALUE (dBuV)	CORRECTION FACTOR (dB/m)
1	*2437.00	101.74 PK			1.02 V	101	69.35	32.39
2	*2437.00	91.35 AV			1.02 V	101	58.96	32.39
3	4874.00	48.37 PK	74.00	-25.63	1.00 V	117	9.96	38.41
4	4874.00	35.49 AV	54.00	-18.51	1.00 V	117	-2.92	38.41

- REMARKS:**
1. Emission level (dBuV/m) = Raw Value (dBuV) + Correction Factor (dB/m).
 2. Correction Factor (dB/m) = Antenna Factor (dB/m) + Cable Factor (dB).
 3. The other emission levels were very low against the limit.
 4. Margin value = Emission level – Limit value.
 5. “ * “: Fundamental frequency.



A D T

EUT TEST CONDITION		MEASUREMENT DETAIL	
CHANNEL	Channel 11	FREQUENCY RANGE	1 ~ 25GHz
INPUT POWER (SYSTEM)	120Vac, 60 Hz	DETECTOR FUNCTION	Peak (PK) Average (AV)
ENVIRONMENTAL CONDITIONS	24deg. C, 64%RH 1000 hPa	TESTED BY	Lori Chiu

ANTENNA POLARITY & TEST DISTANCE: HORIZONTAL AT 3 M								
NO.	FREQ. (MHz)	EMISSION LEVEL (dBuV/m)	LIMIT (dBuV/m)	MARGIN (dB)	ANTENNA HEIGHT (m)	TABLE ANGLE (Degree)	RAW VALUE (dBuV)	CORRECTION FACTOR (dB/m)
1	*2462.00	109.59 PK			1.31 H	280	77.11	32.48
2	*2462.00	99.51 AV			1.31 H	280	67.03	32.48
3	2483.50	65.52 PK	74.00	-8.48	1.31 H	280	32.96	32.56
4	2483.50	51.87 AV	54.00	-2.13	1.31 H	280	19.31	32.56
5	4924.00	48.16 PK	74.00	-25.84	1.00 H	237	9.65	38.51
6	4924.00	35.54 AV	54.00	-18.46	1.00 H	237	-2.97	38.51
ANTENNA POLARITY & TEST DISTANCE: VERTICAL AT 3 M								
NO.	FREQ. (MHz)	EMISSION LEVEL (dBuV/m)	LIMIT (dBuV/m)	MARGIN (dB)	ANTENNA HEIGHT (m)	TABLE ANGLE (Degree)	RAW VALUE (dBuV)	CORRECTION FACTOR (dB/m)
1	*2462.00	101.49 PK			1.03 V	97	69.01	32.48
2	*2462.00	91.13 AV			1.03 V	97	58.65	32.48
3	2483.50	28.45 PK	74.00	-45.55	1.03 V	97	-4.11	32.56
4	2483.50	16.76 AV	54.00	-37.24	1.03 V	97	-15.80	32.56
5	4924.00	48.43 PK	74.00	-25.57	1.00 V	126	9.92	38.51
6	4924.00	35.81 AV	54.00	-18.19	1.00 V	126	-2.70	38.51

- REMARKS:**
1. Emission level (dBuV/m) = Raw Value (dBuV) + Correction Factor (dB/m).
 2. Correction Factor (dB/m) = Antenna Factor (dB/m) + Cable Factor (dB).
 3. The other emission levels were very low against the limit.
 4. Margin value = Emission level – Limit value.
 5. “ * “: Fundamental frequency.



A D T

DRAFT 802.11n (40MHz) OFDM MODULATION

EUT TEST CONDITION		MEASUREMENT DETAIL	
CHANNEL	Channel 1	FREQUENCY RANGE	1 ~ 25GHz
INPUT POWER (SYSTEM)	120Vac, 60 Hz	DETECTOR FUNCTION	Peak (PK) Average (AV)
ENVIRONMENTAL CONDITIONS	24deg. C, 64%RH 1000 hPa	TESTED BY	Lori Chiu

ANTENNA POLARITY & TEST DISTANCE: HORIZONTAL AT 3 M								
NO.	FREQ. (MHz)	EMISSION LEVEL (dBuV/m)	LIMIT (dBuV/m)	MARGIN (dB)	ANTENNA HEIGHT (m)	TABLE ANGLE (Degree)	RAW VALUE (dBuV)	CORRECTION FACTOR (dB/m)
1	2390.00	65.58 PK	74.00	-8.42	1.38 H	281	33.36	32.22
2	2390.00	52.86 AV	54.00	-1.14	1.38 H	281	20.64	32.22
3	*2422.00	105.75 PK			1.38 H	281	73.41	32.34
4	*2422.00	95.69 AV			1.38 H	281	63.35	32.34
5	4844.00	48.15 PK	74.00	-25.85	1.22 H	134	9.79	38.36
6	4844.00	36.19 AV	54.00	-17.81	1.22 H	134	-2.17	38.36
ANTENNA POLARITY & TEST DISTANCE: VERTICAL AT 3 M								
NO.	FREQ. (MHz)	EMISSION LEVEL (dBuV/m)	LIMIT (dBuV/m)	MARGIN (dB)	ANTENNA HEIGHT (m)	TABLE ANGLE (Degree)	RAW VALUE (dBuV)	CORRECTION FACTOR (dB/m)
1	2390.00	60.73 PK	74.00	-13.27	1.00 V	251	28.51	32.22
2	2390.00	48.96 AV	54.00	-5.04	1.00 V	251	16.74	32.22
3	*2422.00	98.07 PK			1.00 V	251	65.73	32.34
4	*2422.00	87.98 AV			1.00 V	251	55.64	32.34
5	4844.00	48.42 PK	74.00	-25.58	1.00 V	198	10.06	38.36
6	4844.00	36.51 AV	54.00	-17.49	1.00 V	198	-1.85	38.36

- REMARKS:**
1. Emission level (dBuV/m) = Raw Value (dBuV) + Correction Factor (dB/m).
 2. Correction Factor (dB/m) = Antenna Factor (dB/m) + Cable Factor (dB).
 3. The other emission levels were very low against the limit.
 4. Margin value = Emission level – Limit value.
 5. “ * ”: Fundamental frequency.



A D T

EUT TEST CONDITION		MEASUREMENT DETAIL	
CHANNEL	Channel 4	FREQUENCY RANGE	1 ~ 25GHz
INPUT POWER (SYSTEM)	120Vac, 60 Hz	DETECTOR FUNCTION	Peak (PK) Average (AV)
ENVIRONMENTAL CONDITIONS	24deg. C, 64%RH 1000 hPa	TESTED BY	Lori Chiu

ANTENNA POLARITY & TEST DISTANCE: HORIZONTAL AT 3 M								
NO.	FREQ. (MHz)	EMISSION LEVEL (dBuV/m)	LIMIT (dBuV/m)	MARGIN (dB)	ANTENNA HEIGHT (m)	TABLE ANGLE (Degree)	RAW VALUE (dBuV)	CORRECTION FACTOR (dB/m)
1	*2437.00	106.90 PK			1.33 H	280	74.51	32.39
2	*2437.00	96.73 AV			1.33 H	280	64.34	32.39
3	4874.00	48.51 PK	74.00	-25.49	1.21 H	142	10.10	38.41
4	4874.00	36.47 AV	54.00	-17.53	1.21 H	142	-1.94	38.41
ANTENNA POLARITY & TEST DISTANCE: VERTICAL AT 3 M								
NO.	FREQ. (MHz)	EMISSION LEVEL (dBuV/m)	LIMIT (dBuV/m)	MARGIN (dB)	ANTENNA HEIGHT (m)	TABLE ANGLE (Degree)	RAW VALUE (dBuV)	CORRECTION FACTOR (dB/m)
1	*2437.00	99.15 PK			1.00 V	246	66.76	32.39
2	*2437.00	89.04 AV			1.00 V	246	56.65	32.39
3	4874.00	48.76 PK	74.00	-25.24	1.00 V	203	10.35	38.41
4	4874.00	36.82 AV	54.00	-17.18	1.00 V	203	-1.59	38.41

- REMARKS:**
1. Emission level (dBuV/m) = Raw Value (dBuV) + Correction Factor (dB/m).
 2. Correction Factor (dB/m) = Antenna Factor (dB/m) + Cable Factor (dB).
 3. The other emission levels were very low against the limit.
 4. Margin value = Emission level – Limit value.
 5. “ * “: Fundamental frequency.



A D T

EUT TEST CONDITION		MEASUREMENT DETAIL	
CHANNEL	Channel 7	FREQUENCY RANGE	1 ~ 25GHz
INPUT POWER (SYSTEM)	120Vac, 60 Hz	DETECTOR FUNCTION	Peak (PK) Average (AV)
ENVIRONMENTAL CONDITIONS	24deg. C, 64%RH 1000 hPa	TESTED BY	Lori Chiu

ANTENNA POLARITY & TEST DISTANCE: HORIZONTAL AT 3 M								
NO.	FREQ. (MHz)	EMISSION LEVEL (dBuV/m)	LIMIT (dBuV/m)	MARGIN (dB)	ANTENNA HEIGHT (m)	TABLE ANGLE (Degree)	RAW VALUE (dBuV)	CORRECTION FACTOR (dB/m)
1	*2452.00	105.78 PK			1.32 H	280	73.33	32.45
2	*2452.00	95.66 AV			1.32 H	280	63.21	32.45
3	2483.50	66.03 PK	74.00	-7.97	1.32 H	281	33.47	32.56
4	2483.50	52.92 AV	54.00	-1.08	1.32 H	281	20.36	32.56
5	4904.00	48.43 PK	74.00	-25.57	1.19 H	118	9.97	38.46
6	4904.00	36.35 AV	54.00	-17.65	1.19 H	118	-2.11	38.46
ANTENNA POLARITY & TEST DISTANCE: VERTICAL AT 3 M								
NO.	FREQ. (MHz)	EMISSION LEVEL (dBuV/m)	LIMIT (dBuV/m)	MARGIN (dB)	ANTENNA HEIGHT (m)	TABLE ANGLE (Degree)	RAW VALUE (dBuV)	CORRECTION FACTOR (dB/m)
1	*2452.00	98.04 PK			1.03 V	96	65.59	32.45
2	*2452.00	87.96 AV			1.03 V	96	55.51	32.45
3	2483.50	60.51 PK	74.00	-13.49	1.03 V	96	27.95	32.56
4	2483.50	48.95 AV	54.00	-5.05	1.03 V	96	16.39	32.56
5	4904.00	48.72 PK	74.00	-25.28	1.00 V	208	10.26	38.46
6	4904.00	36.59 AV	54.00	-17.41	1.00 V	208	-1.87	38.46

- REMARKS:**
1. Emission level (dBuV/m) = Raw Value (dBuV) + Correction Factor (dB/m).
 2. Correction Factor (dB/m) = Antenna Factor (dB/m) + Cable Factor (dB).
 3. The other emission levels were very low against the limit.
 4. Margin value = Emission level – Limit value.
 5. “ * “: Fundamental frequency.



A D T

BELOW 1GHz WORST-CASE DATA : 802.11g OFDM MODULATION

EUT TEST CONDITION		MEASUREMENT DETAIL	
CHANNEL	Channel 6	FREQUENCY RANGE	Below 1000MHz
INPUT POWER (SYSTEM)	120Vac, 60 Hz	DETECTOR FUNCTION	Quasi-Peak
ENVIRONMENTAL CONDITIONS	23deg. C, 70%RH 999 hPa	TESTED BY	Mark Liao
TEST MODE	A		

ANTENNA POLARITY & TEST DISTANCE: HORIZONTAL AT 3 M								
NO.	FREQ. (MHz)	EMISSION LEVEL (dBuV/m)	LIMIT (dBuV/m)	MARGIN (dB)	ANTENNA HEIGHT (m)	TABLE ANGLE (Degree)	RAW VALUE (dBuV)	CORRECTION FACTOR (dB/m)
1	96.01	36.51 QP	43.50	-6.99	2.00 H	121	27.22	9.29
2	164.06	37.61 QP	43.50	-5.89	1.25 H	271	24.21	13.40
3	383.76	32.98 QP	46.00	-13.02	1.00 H	307	17.32	15.67
4	640.41	33.44 QP	46.00	-12.56	1.25 H	289	11.20	22.24
5	768.73	31.16 QP	46.00	-14.84	1.00 H	313	6.70	24.46
6	949.55	34.00 QP	46.00	-12.00	1.25 H	73	7.51	26.49
ANTENNA POLARITY & TEST DISTANCE: VERTICAL AT 3 M								
NO.	FREQ. (MHz)	EMISSION LEVEL (dBuV/m)	LIMIT (dBuV/m)	MARGIN (dB)	ANTENNA HEIGHT (m)	TABLE ANGLE (Degree)	RAW VALUE (dBuV)	CORRECTION FACTOR (dB/m)
1	57.12	36.24 QP	40.00	-3.76	1.00 V	220	22.76	13.48
2	97.95	39.80 QP	43.50	-3.70	1.25 V	115	30.49	9.31
3	383.76	31.82 QP	46.00	-14.18	1.25 V	355	16.15	15.67
4	640.41	36.79 QP	46.00	-9.21	1.25 V	352	14.56	22.24
5	768.73	30.11 QP	46.00	-15.89	1.25 V	10	5.65	24.46
6	947.60	36.33 QP	46.00	-9.67	1.00 V	193	9.86	26.47

- REMARKS:**
1. Emission level (dBuV/m) = Raw Value (dBuV) + Correction Factor (dB/m).
 2. Correction Factor (dB/m) = Antenna Factor (dB/m) + Cable Factor (dB).
 3. The other emission levels were very low against the limit.
 4. Margin value = Emission level – Limit value.



A D T

EUT TEST CONDITION		MEASUREMENT DETAIL	
CHANNEL	Channel 6	FREQUENCY RANGE	Below 1000MHz
INPUT POWER (SYSTEM)	120Vac, 60 Hz	DETECTOR FUNCTION	Quasi-Peak
ENVIRONMENTAL CONDITIONS	23deg. C, 70%RH 999 hPa	TESTED BY	Mark Liao
TEST MODE	B		

ANTENNA POLARITY & TEST DISTANCE: HORIZONTAL AT 3 M								
NO.	FREQ. (MHz)	EMISSION LEVEL (dBuV/m)	LIMIT (dBuV/m)	MARGIN (dB)	ANTENNA HEIGHT (m)	TABLE ANGLE (Degree)	RAW VALUE (dBuV)	CORRECTION FACTOR (dB/m)
1	127.11	33.32 QP	43.50	-10.18	2.00 H	286	21.29	12.03
2	173.78	30.10 QP	43.50	-13.40	2.00 H	283	17.44	12.66
3	249.60	34.35 QP	46.00	-11.65	1.00 H	79	21.54	12.81
4	500.42	34.28 QP	46.00	-11.72	1.50 H	313	15.02	19.25
5	640.41	33.57 QP	46.00	-12.43	1.25 H	52	11.34	22.24
6	955.38	34.70 QP	46.00	-11.30	1.25 H	343	8.18	26.51
ANTENNA POLARITY & TEST DISTANCE: VERTICAL AT 3 M								
NO.	FREQ. (MHz)	EMISSION LEVEL (dBuV/m)	LIMIT (dBuV/m)	MARGIN (dB)	ANTENNA HEIGHT (m)	TABLE ANGLE (Degree)	RAW VALUE (dBuV)	CORRECTION FACTOR (dB/m)
1	39.62	34.55 QP	40.00	-5.45	1.50 V	172	22.10	12.45
2	144.61	35.77 QP	43.50	-7.73	1.00 V	220	22.61	13.16
3	383.76	30.61 QP	46.00	-15.39	1.50 V	7	14.95	15.67
4	500.42	31.85 QP	46.00	-14.15	1.00 V	166	12.60	19.25
5	640.41	32.22 QP	46.00	-13.78	1.50 V	238	9.99	22.24
6	949.55	37.35 QP	46.00	-8.65	1.25 V	28	10.86	26.49

- REMARKS:**
1. Emission level (dBuV/m) = Raw Value (dBuV) + Correction Factor (dB/m).
 2. Correction Factor (dB/m) = Antenna Factor (dB/m) + Cable Factor (dB).
 3. The other emission levels were very low against the limit.
 4. Margin value = Emission level – Limit value.



A D T

EUT TEST CONDITION		MEASUREMENT DETAIL	
CHANNEL	Channel 6	FREQUENCY RANGE	Below 1000MHz
INPUT POWER (SYSTEM)	120Vac, 60 Hz	DETECTOR FUNCTION	Quasi-Peak
ENVIRONMENTAL CONDITIONS	23deg. C, 70%RH 999 hPa	TESTED BY	Mark Liao
TEST MODE	C		

ANTENNA POLARITY & TEST DISTANCE: HORIZONTAL AT 3 M								
NO.	FREQ. (MHz)	EMISSION LEVEL (dBuV/m)	LIMIT (dBuV/m)	MARGIN (dB)	ANTENNA HEIGHT (m)	TABLE ANGLE (Degree)	RAW VALUE (dBuV)	CORRECTION FACTOR (dB/m)
1	105.73	39.90 QP	43.50	-3.60	2.00 H	40	29.88	10.02
2	249.60	36.42 QP	46.00	-9.58	1.00 H	85	23.61	12.81
3	500.42	33.55 QP	46.00	-12.45	2.00 H	346	14.29	19.25
4	718.18	39.67 QP	46.00	-6.33	2.00 H	169	16.50	23.17
5	799.84	40.32 QP	46.00	-5.68	1.00 H	136	15.00	25.32
6	879.55	36.03 QP	46.00	-9.97	1.00 H	172	10.12	25.91
ANTENNA POLARITY & TEST DISTANCE: VERTICAL AT 3 M								
NO.	FREQ. (MHz)	EMISSION LEVEL (dBuV/m)	LIMIT (dBuV/m)	MARGIN (dB)	ANTENNA HEIGHT (m)	TABLE ANGLE (Degree)	RAW VALUE (dBuV)	CORRECTION FACTOR (dB/m)
1	105.73	38.95 QP	43.50	-4.55	1.25 V	328	28.92	10.02
2	239.88	35.20 QP	46.00	-10.80	1.50 V	178	22.82	12.38
3	560.69	36.79 QP	46.00	-9.21	2.00 V	25	15.78	21.01
4	718.18	43.12 QP	46.00	-2.88	1.00 V	10	19.95	23.17
5	799.84	43.71 QP	46.00	-2.29	1.50 V	190	18.39	25.32
6	881.50	41.29 QP	46.00	-4.71	1.00 V	91	15.36	25.93

- REMARKS:**
1. Emission level (dBuV/m) = Raw Value (dBuV) + Correction Factor (dB/m).
 2. Correction Factor (dB/m) = Antenna Factor (dB/m) + Cable Factor (dB).
 3. The other emission levels were very low against the limit.
 4. Margin value = Emission level – Limit value.



A D T

EUT TEST CONDITION		MEASUREMENT DETAIL	
CHANNEL	Channel 6	FREQUENCY RANGE	Below 1000MHz
INPUT POWER (SYSTEM)	120Vac, 60 Hz	DETECTOR FUNCTION	Quasi-Peak
ENVIRONMENTAL CONDITIONS	23deg. C, 69%RH 999 hPa	TESTED BY	Lori Chiu
TEST MODE	D		

ANTENNA POLARITY & TEST DISTANCE: HORIZONTAL AT 3 M								
NO.	FREQ. (MHz)	EMISSION LEVEL (dBuV/m)	LIMIT (dBuV/m)	MARGIN (dB)	ANTENNA HEIGHT (m)	TABLE ANGLE (Degree)	RAW VALUE (dBuV)	CORRECTION FACTOR (dB/m)
1	144.61	30.65 QP	43.50	-12.85	1.00 H	226	17.48	13.16
2	249.60	37.50 QP	46.00	-8.50	1.25 H	274	24.69	12.81
3	500.42	33.37 QP	46.00	-12.63	1.50 H	229	14.12	19.25
4	549.03	32.07 QP	46.00	-13.93	1.50 H	145	11.33	20.74
5	640.41	32.70 QP	46.00	-13.30	1.50 H	217	10.46	22.24
6	947.60	34.35 QP	46.00	-11.65	1.00 H	82	7.88	26.47
ANTENNA POLARITY & TEST DISTANCE: VERTICAL AT 3 M								
NO.	FREQ. (MHz)	EMISSION LEVEL (dBuV/m)	LIMIT (dBuV/m)	MARGIN (dB)	ANTENNA HEIGHT (m)	TABLE ANGLE (Degree)	RAW VALUE (dBuV)	CORRECTION FACTOR (dB/m)
1	45.45	34.69 QP	40.00	-5.31	1.50 V	289	22.11	12.58
2	94.06	31.23 QP	43.50	-12.27	1.50 V	226	21.97	9.26
3	103.78	36.73 QP	43.50	-6.77	1.00 V	274	26.95	9.79
4	144.61	31.98 QP	43.50	-11.52	1.00 V	301	18.81	13.16
5	500.42	32.14 QP	46.00	-13.86	1.00 V	43	12.89	19.25
6	947.60	35.42 QP	46.00	-10.58	1.25 V	16	8.95	26.47

- REMARKS:**
1. Emission level (dBuV/m) = Raw Value (dBuV) + Correction Factor (dB/m).
 2. Correction Factor (dB/m) = Antenna Factor (dB/m) + Cable Factor (dB).
 3. The other emission levels were very low against the limit.
 4. Margin value = Emission level – Limit value.



4.2 CONDUCTED EMISSION MEASUREMENT

4.2.1 LIMITS OF CONDUCTED EMISSION MEASUREMENT

FREQUENCY OF EMISSION (MHz)	CONDUCTED LIMIT (dBµV)	
	Quasi-peak	Average
0.15 ~ 0.5	66 to 56	56 to 46
0.5 ~ 5	56	46
5 ~ 30	60	50

- NOTE:**
1. The lower limit shall apply at the transition frequencies.
 2. The limit decreases in line with the logarithm of the frequency in the range of 0.15 to 0.50MHz.
 3. All emanations from a class A/B digital device or system, including any network of conductors and apparatus connected thereto, shall not exceed the level of field strengths specified above.

4.2.2 TEST INSTRUMENTS

DESCRIPTION & MANUFACTURER	MODEL NO.	SERIAL NO.	DATE OF CALIBRATION	DUE DATE OF CALIBRATION
Test Receiver ROHDE & SCHWARZ	ESCS30	100288	Sep. 22, 2008	Sep. 21, 2009
RF signal cable Woken	5D-FB	Cable-HYCO2-01	Dec. 31, 2008	Dec. 30, 2009
LISN ROHDE & SCHWARZ	ESH2-Z5	100100	Dec. 29, 2008	Dec. 28, 2009
LISN ROHDE & SCHWARZ	ESH3-Z5	100311	Jul. 29, 2009	Jul. 28, 2010
Software ADT	ADT_Cond_ V7.3.7	NA	NA	NA

- NOTE:**
1. The calibration interval of the above test instruments is 12 months and the calibrations are traceable to NML/ROC and NIST/USA.
 2. The test was performed in HwaYa Shielded Room 2.
 3. The VCCI Site Registration No. is C-2047.



A D T

4.2.3 TEST PROCEDURES

- a. The EUT was placed 0.4 meters from the conducting wall of the shielded room with EUT being connected to the power mains through a line impedance stabilization network (LISN). Other support units were connected to the power mains through another LISN. The two LISNs provide 50 ohm/ 50uH of coupling impedance for the measuring instrument.
- b. Both lines of the power mains connected to the EUT were checked for maximum conducted interference.
- c. The frequency range from 150kHz to 30MHz was searched. Emission levels under (Limit - 20dB) was not recorded.

NOTE: All modes of operation were investigated and the worst-case emissions are reported.

4.2.4 DEVIATION FROM TEST STANDARD

No deviation.

4.2.5 TEST SETUP

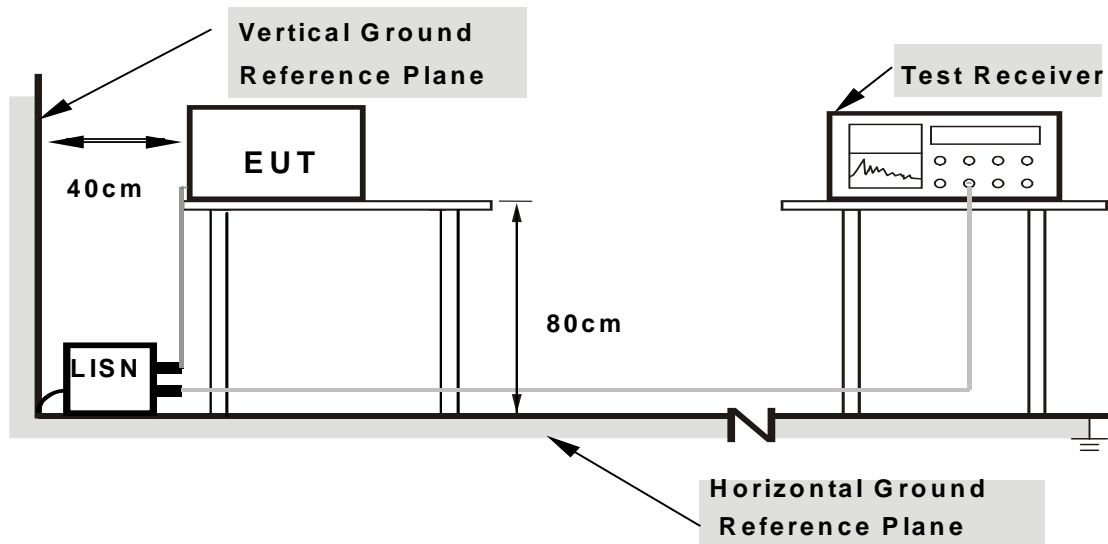

- Note:**
1. Support units were connected to second LISN.
 2. Both of LISNs (AMN) are 80 cm from EUT and at least 80 from other units and other metal planes

For the actual test configuration, please refer to the attached file (Test Setup Photo).

4.2.6 EUT OPERATING CONDITIONS

Same as 4.1.6.

4.2.7 TEST RESULTS

CONDUCTED WORST-CASE DATA : 802.11g OFDM MODULATION

EUT TEST CONDITION		MEASUREMENT DETAIL	
CHANNEL	Channel 6	PHASE	Line 1
MODULATION TYPE	BPSK	INPUT POWER	120Vac, 60Hz
ENVIRONMENTAL CONDITIONS	26deg. C, 67%RH, 1007hPa	6dB BANDWIDTH	9kHz
TEST MODE	A	TESTED BY	Dean Wang

No	Freq. [MHz]	Corr. Factor (dB)	Reading Value [dB (uV)]		Emission Level [dB (uV)]		Limit [dB (uV)]		Margin (dB)	
			Q.P.	AV.	Q.P.	AV.	Q.P.	AV.	Q.P.	AV.
1	0.153	0.13	54.00	-	54.13	-	65.86	55.86	-11.73	-
2	0.198	0.13	50.34	-	50.47	-	63.69	53.69	-13.22	-
3	0.527	0.15	45.27	-	45.42	-	56.00	46.00	-10.58	-
4	0.608	0.15	49.66	44.72	49.81	44.87	56.00	46.00	-6.19	-1.13
5	3.206	0.24	43.89	-	44.13	-	56.00	46.00	-11.87	-
6	6.492	0.34	36.60	-	36.94	-	60.00	50.00	-23.06	-

- REMARKS:**
1. Q.P. and AV. are abbreviations of quasi-peak and average individually.
 2. "-": The Quasi-peak reading value also meets average limit and measurement with the average detector is unnecessary.
 3. The emission levels of other frequencies were very low against the limit.
 4. Margin value = Emission level - Limit value
 5. Correction factor = Insertion loss + Cable loss
 6. Emission Level = Correction Factor + Reading Value.

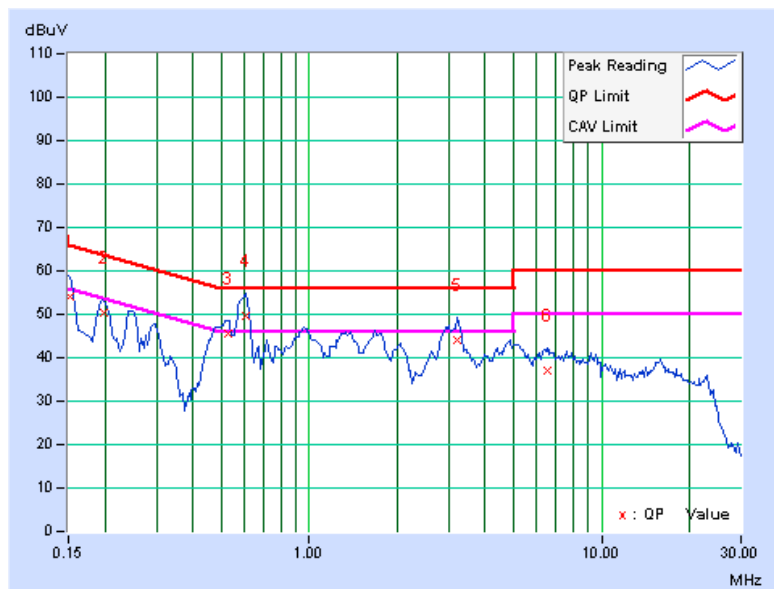



A D T

EUT TEST CONDITION		MEASUREMENT DETAIL	
CHANNEL	Channel 6	PHASE	Line 2
MODULATION TYPE	BPSK	INPUT POWER	120Vac, 60Hz
ENVIRONMENTAL CONDITIONS	26deg. C, 67%RH, 1007hPa	6dB BANDWIDTH	9kHz
TEST MODE	A	TESTED BY	Dean Wang

No	Freq. [MHz]	Corr. Factor (dB)	Reading Value [dB (uV)]		Emission Level [dB (uV)]		Limit [dB (uV)]		Margin (dB)	
			Q.P.	AV.	Q.P.	AV.	Q.P.	AV.	Q.P.	AV.
1	0.152	0.13	51.72	-	51.85	-	65.92	55.92	-14.07	-
2	0.198	0.13	47.80	-	47.93	-	63.69	53.69	-15.76	-
3	0.599	0.16	48.56	43.42	48.72	43.58	56.00	46.00	-7.28	-2.42
4	1.738	0.19	41.75	-	41.94	-	56.00	46.00	-14.06	-
5	3.145	0.26	41.62	-	41.88	-	56.00	46.00	-14.12	-
6	6.207	0.37	35.63	-	36.00	-	60.00	50.00	-24.00	-

- REMARKS:**
1. Q.P. and AV. are abbreviations of quasi-peak and average individually.
 2. "-": The Quasi-peak reading value also meets average limit and measurement with the average detector is unnecessary.
 3. The emission levels of other frequencies were very low against the limit.
 4. Margin value = Emission level - Limit value
 5. Correction factor = Insertion loss + Cable loss
 6. Emission Level = Correction Factor + Reading Value.

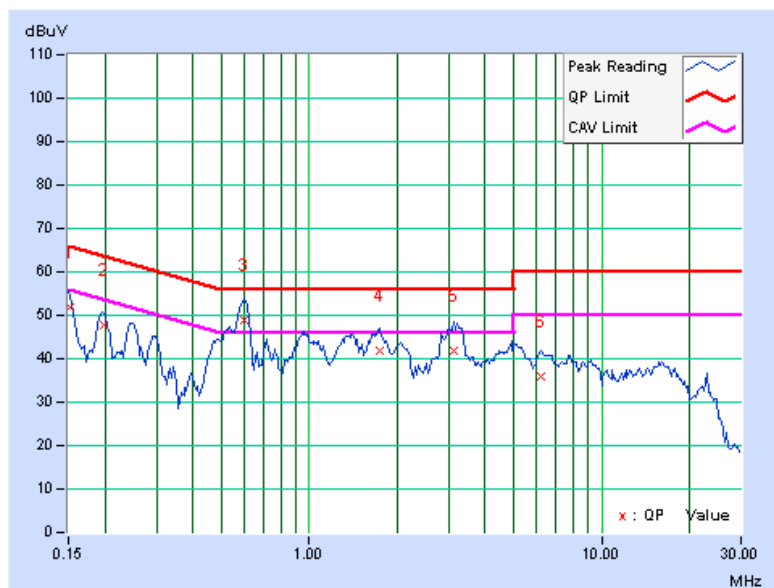



A D T

EUT TEST CONDITION		MEASUREMENT DETAIL	
CHANNEL	Channel 6	PHASE	Line 1
MODULATION TYPE	BPSK	INPUT POWER	120Vac, 60Hz
ENVIRONMENTAL CONDITIONS	26deg. C, 67%RH, 1007hPa	6dB BANDWIDTH	9kHz
TEST MODE	B	TESTED BY	Dean Wang

No	Freq. [MHz]	Corr. Factor (dB)	Reading Value [dB (uV)]		Emission Level [dB (uV)]		Limit [dB (uV)]		Margin (dB)	
			Q.P.	AV.	Q.P.	AV.	Q.P.	AV.	Q.P.	AV.
1	0.152	0.13	37.39	-	37.52	-	65.90	55.90	-28.38	-
2	0.197	0.13	33.01	-	33.14	-	63.75	53.75	-30.61	-
3	0.822	0.16	28.71	-	28.87	-	56.00	46.00	-27.13	-
4	4.027	0.28	29.78	-	30.06	-	56.00	46.00	-25.94	-
5	7.516	0.37	30.44	-	30.81	-	60.00	50.00	-29.19	-
6	20.320	0.67	32.63	-	33.30	-	60.00	50.00	-26.70	-

- REMARKS:**
1. Q.P. and AV. are abbreviations of quasi-peak and average individually.
 2. "-": The Quasi-peak reading value also meets average limit and measurement with the average detector is unnecessary.
 3. The emission levels of other frequencies were very low against the limit.
 4. Margin value = Emission level - Limit value
 5. Correction factor = Insertion loss + Cable loss
 6. Emission Level = Correction Factor + Reading Value.

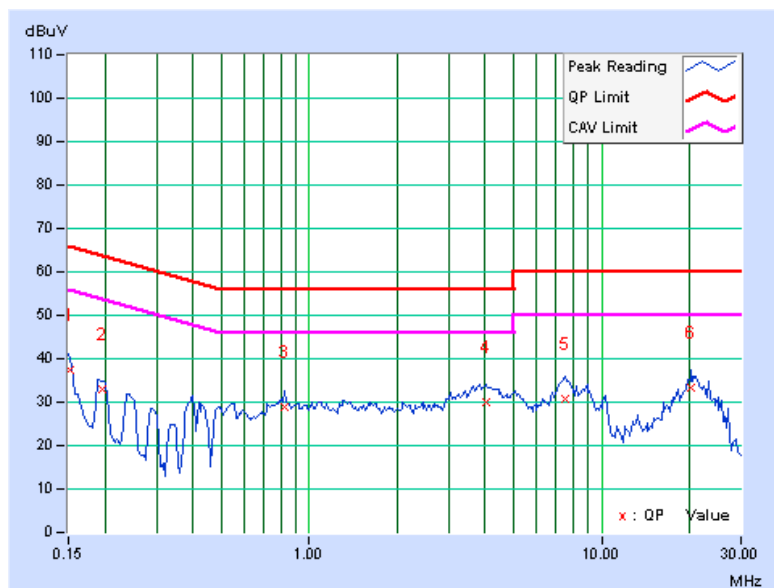



A D T

EUT TEST CONDITION		MEASUREMENT DETAIL	
CHANNEL	Channel 6	PHASE	Line 2
MODULATION TYPE	BPSK	INPUT POWER	120Vac, 60Hz
ENVIRONMENTAL CONDITIONS	26deg. C, 67%RH, 1007hPa	6dB BANDWIDTH	9kHz
TEST MODE	B	TESTED BY	Dean Wang

No	Freq. [MHz]	Corr. Factor (dB)	Reading Value [dB (uV)]		Emission Level [dB (uV)]		Limit [dB (uV)]		Margin (dB)	
			Q.P.	AV.	Q.P.	AV.	Q.P.	AV.	Q.P.	AV.
1	0.152	0.13	39.73	-	39.86	-	65.90	55.90	-26.04	-
2	0.196	0.13	34.07	-	34.20	-	63.80	53.80	-29.60	-
3	2.434	0.22	29.98	-	30.20	-	56.00	46.00	-25.80	-
4	4.273	0.31	29.46	-	29.77	-	56.00	46.00	-26.23	-
5	7.336	0.41	31.70	-	32.11	-	60.00	50.00	-27.89	-
6	20.195	0.82	32.44	-	33.26	-	60.00	50.00	-26.74	-

- REMARKS:**
1. Q.P. and AV. are abbreviations of quasi-peak and average individually.
 2. "-": The Quasi-peak reading value also meets average limit and measurement with the average detector is unnecessary.
 3. The emission levels of other frequencies were very low against the limit.
 4. Margin value = Emission level - Limit value
 5. Correction factor = Insertion loss + Cable loss
 6. Emission Level = CORRECTION FACTOR + READING VALUE.

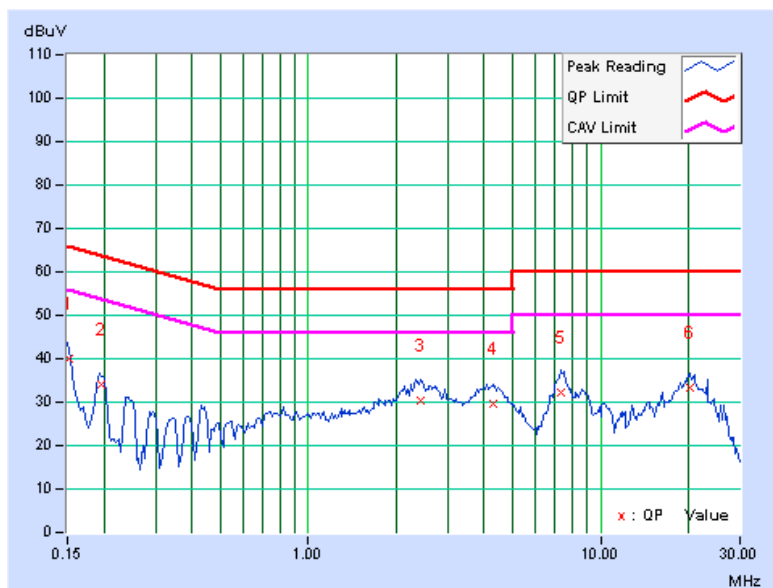



A D T

EUT TEST CONDITION		MEASUREMENT DETAIL	
CHANNEL	Channel 6	PHASE	Line 1
MODULATION TYPE	BPSK	INPUT POWER	120Vac, 60Hz
ENVIRONMENTAL CONDITIONS	26deg. C, 67%RH, 1007hPa	6dB BANDWIDTH	9kHz
TEST MODE	C	TESTED BY	Dean Wang

No	Freq. [MHz]	Corr. Factor (dB)	Reading Value [dB (uV)]		Emission Level [dB (uV)]		Limit [dB (uV)]		Margin (dB)	
			Q.P.	AV.	Q.P.	AV.	Q.P.	AV.	Q.P.	AV.
1	0.151	0.13	42.90	-	43.03	-	65.93	55.93	-22.90	-
2	0.222	0.13	43.27	-	43.40	-	62.76	52.76	-19.36	-
3	0.342	0.14	35.01	-	35.15	-	59.14	49.14	-24.00	-
4	0.689	0.15	28.31	-	28.46	-	56.00	46.00	-27.54	-
5	1.828	0.19	26.41	-	26.60	-	56.00	46.00	-29.40	-
6	10.625	0.45	33.24	-	33.69	-	60.00	50.00	-26.31	-

- REMARKS:**
1. Q.P. and AV. are abbreviations of quasi-peak and average individually.
 2. "-": The Quasi-peak reading value also meets average limit and measurement with the average detector is unnecessary.
 3. The emission levels of other frequencies were very low against the limit.
 4. Margin value = Emission level - Limit value
 5. Correction factor = Insertion loss + Cable loss
 6. Emission Level = Correction Factor + Reading Value.

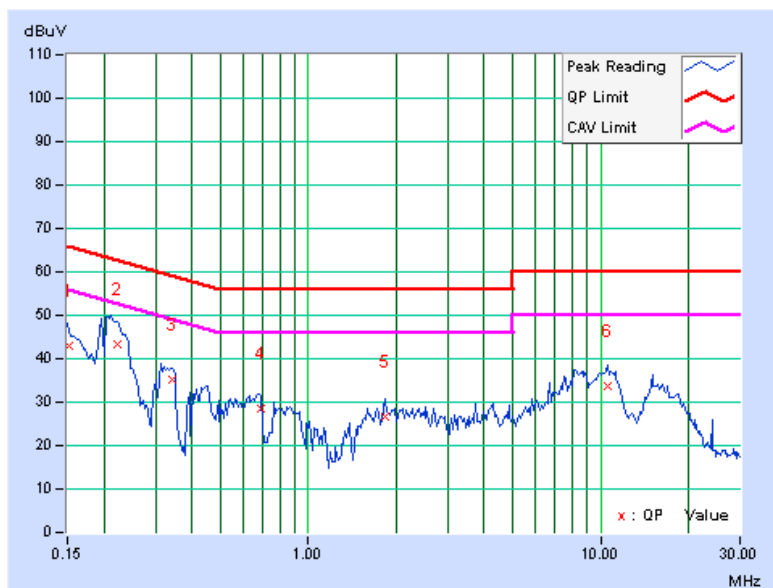



A D T

EUT TEST CONDITION		MEASUREMENT DETAIL	
CHANNEL	Channel 6	PHASE	Line 2
MODULATION TYPE	BPSK	INPUT POWER	120Vac, 60Hz
ENVIRONMENTAL CONDITIONS	26deg. C, 67%RH, 1007hPa	6dB BANDWIDTH	9kHz
TEST MODE	C	TESTED BY	Dean Wang

No	Freq. [MHz]	Corr. Factor (dB)	Reading Value [dB (uV)]		Emission Level [dB (uV)]		Limit [dB (uV)]		Margin (dB)	
			Q.P.	AV.	Q.P.	AV.	Q.P.	AV.	Q.P.	AV.
1	0.151	0.13	40.17	-	40.30	-	65.92	55.92	-25.62	-
2	0.218	0.13	43.81	-	43.94	-	62.91	52.91	-18.96	-
3	0.344	0.14	34.93	-	35.07	-	59.11	49.11	-24.03	-
4	1.827	0.19	26.41	-	26.60	-	56.00	46.00	-29.40	-
5	3.691	0.28	24.67	-	24.95	-	56.00	46.00	-31.05	-
6	10.449	0.51	32.48	-	32.99	-	60.00	50.00	-27.01	-

- REMARKS:**
1. Q.P. and AV. are abbreviations of quasi-peak and average individually.
 2. "-": The Quasi-peak reading value also meets average limit and measurement with the average detector is unnecessary.
 3. The emission levels of other frequencies were very low against the limit.
 4. Margin value = Emission level - Limit value
 5. Correction factor = Insertion loss + Cable loss
 6. Emission Level = Correction Factor + Reading Value.

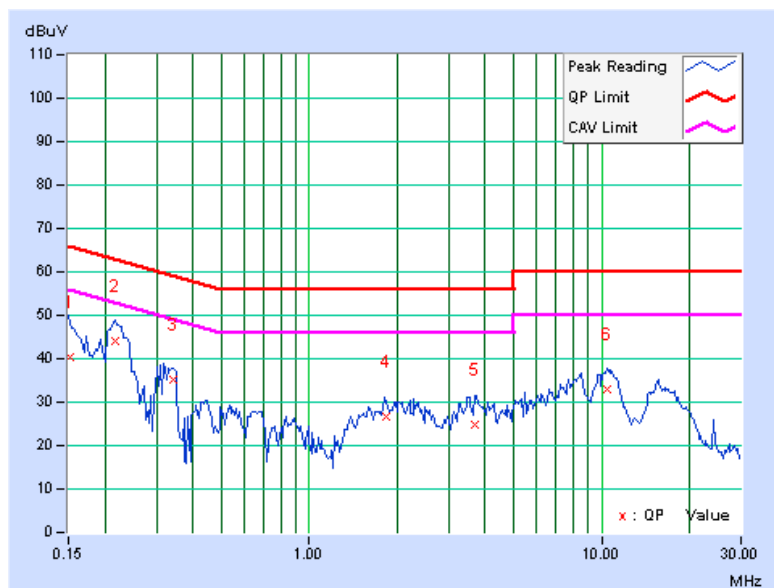



A D T

EUT TEST CONDITION		MEASUREMENT DETAIL	
CHANNEL	Channel 6	PHASE	Line 1
MODULATION TYPE	BPSK	INPUT POWER	120Vac, 60Hz
ENVIRONMENTAL CONDITIONS	23deg. C, 68%RH, 1007hPa	6dB BANDWIDTH	9kHz
TEST MODE	D	TESTED BY	Sun Lin

No	Freq. [MHz]	Corr. Factor (dB)	Reading Value [dB (uV)]		Emission Level [dB (uV)]		Limit [dB (uV)]		Margin (dB)	
			Q.P.	AV.	Q.P.	AV.	Q.P.	AV.	Q.P.	AV.
1	0.162	0.13	40.65	-	40.78	-	65.38	55.38	-24.60	-
2	0.345	0.14	38.95	-	39.09	-	59.07	49.07	-19.99	-
3	0.884	0.16	33.66	-	33.82	-	56.00	46.00	-22.18	-
4	2.188	0.20	34.95	-	35.15	-	56.00	46.00	-20.85	-
5	3.164	0.24	35.03	-	35.27	-	56.00	46.00	-20.73	-
6	8.145	0.38	38.40	-	38.78	-	60.00	50.00	-21.22	-

- REMARKS:**
1. Q.P. and AV. are abbreviations of quasi-peak and average individually.
 2. "-": The Quasi-peak reading value also meets average limit and measurement with the average detector is unnecessary.
 3. The emission levels of other frequencies were very low against the limit.
 4. Margin value = Emission level - Limit value
 5. Correction factor = Insertion loss + Cable loss
 6. Emission Level = Correction Factor + Reading Value.

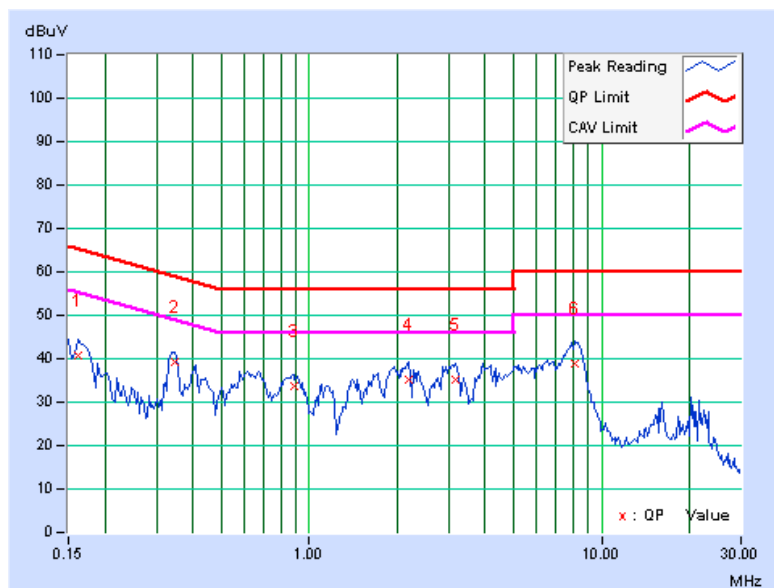



A D T

EUT TEST CONDITION		MEASUREMENT DETAIL	
CHANNEL	Channel 6	PHASE	Line 2
MODULATION TYPE	BPSK	INPUT POWER	120Vac, 60Hz
ENVIRONMENTAL CONDITIONS	23deg. C, 68%RH, 1007hPa	6dB BANDWIDTH	9kHz
TEST MODE	D	TESTED BY	Sun Lin

No	Freq. [MHz]	Corr. Factor (dB)	Reading Value [dB (uV)]		Emission Level [dB (uV)]		Limit [dB (uV)]		Margin (dB)	
			Q.P.	AV.	Q.P.	AV.	Q.P.	AV.	Q.P.	AV.
1	0.166	0.13	42.93	-	43.06	-	65.18	55.18	-22.12	-
2	0.345	0.14	39.07	-	39.21	-	59.07	49.07	-19.86	-
3	0.677	0.16	31.04	-	31.20	-	56.00	46.00	-24.80	-
4	0.900	0.17	32.51	-	32.68	-	56.00	46.00	-23.32	-
5	2.414	0.22	33.24	-	33.46	-	56.00	46.00	-22.54	-
6	8.172	0.44	36.72	-	37.16	-	60.00	50.00	-22.84	-

- REMARKS:**
1. Q.P. and AV. are abbreviations of quasi-peak and average individually.
 2. "-": The Quasi-peak reading value also meets average limit and measurement with the average detector is unnecessary.
 3. The emission levels of other frequencies were very low against the limit.
 4. Margin value = Emission level - Limit value
 5. Correction factor = Insertion loss + Cable loss
 6. Emission Level = Correction Factor + Reading Value.

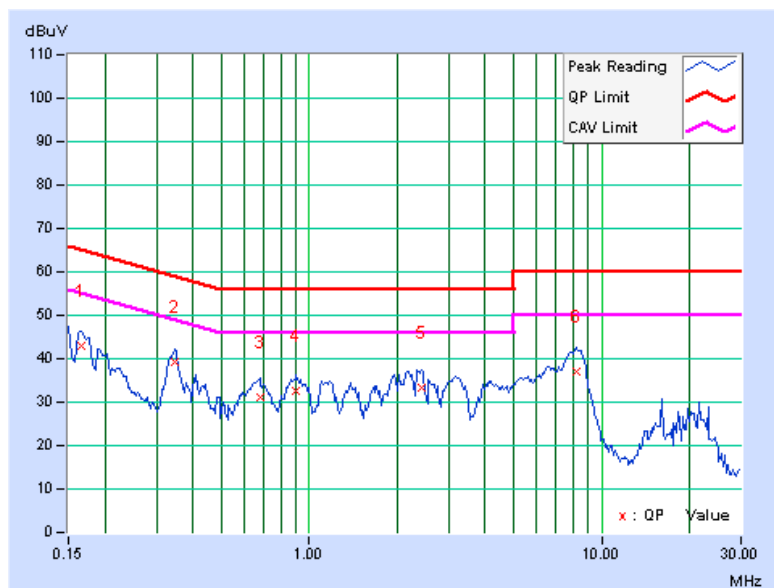

4.3 6dB BANDWIDTH MEASUREMENT

4.3.1 LIMITS OF 6dB BANDWIDTH MEASUREMENT

The minimum of 6dB Bandwidth Measurement is 0.5 MHz.

4.3.2 TEST INSTRUMENTS

DESCRIPTION & MANUFACTURER	MODEL NO.	SERIAL NO.	DATE OF CALIBRATION	DUE DATE OF CALIBRATION
SPECTRUM ANALYZER R&S	FSP40	100040	Jul. 07, 2009	Jul. 06, 2010

NOTE: The calibration interval of the above test instruments is 12 months and the calibrations are traceable to NML/ROC and NIST/USA.

4.3.3 TEST PROCEDURE

The transmitter output was connected to the spectrum analyzer through an attenuator. The bandwidth of the fundamental frequency was measured by spectrum analyzer with 100kHz RBW and 300kHz VBW. The 6dB bandwidth is defined as the total spectrum the power of which is higher than peak power minus 6dB.

4.3.4 DEVIATION FROM TEST STANDARD

No deviation.

4.3.5 TEST SETUP

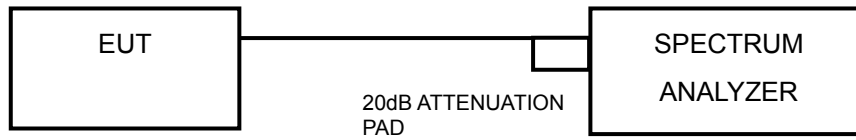

4.3.6 EUT OPERATING CONDITIONS

The software provided by client to enable the EUT under transmission condition continuously at lowest, middle and highest channel frequencies individually.



A D T

4.3.7 TEST RESULTS

802.11b DSSS MODULATION

MODULATION TYPE	DBPSK	TRANSFER RATE	1.0Mbps
INPUT POWER	120Vac, 60Hz	ENVIRONMENTAL CONDITIONS	24 deg.C, 64 %RH, 1009 hPa
TESTED BY	Lori Chiu		

CHANNEL	CHANNEL FREQUENCY (MHz)	6dB BANDWIDTH (MHz)		MINIMUM LIMIT (MHz)	PASS / FAIL
		CHAIN 0	CHAIN 1		
1	2412	11.17	11.12	0.5	PASS
6	2437	12.12	11.14	0.5	PASS
11	2462	12.15	10.21	0.5	PASS



A D T

FOR CHAIN 0: CH 1

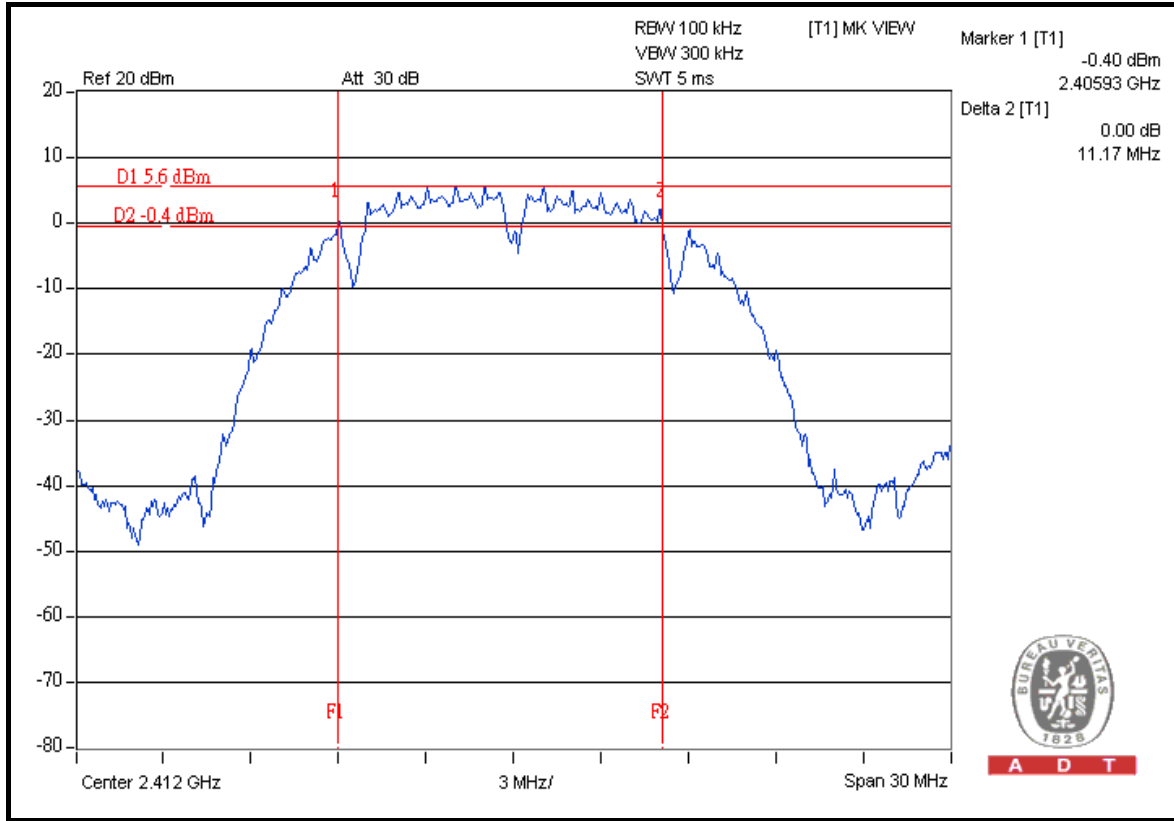

CH 6

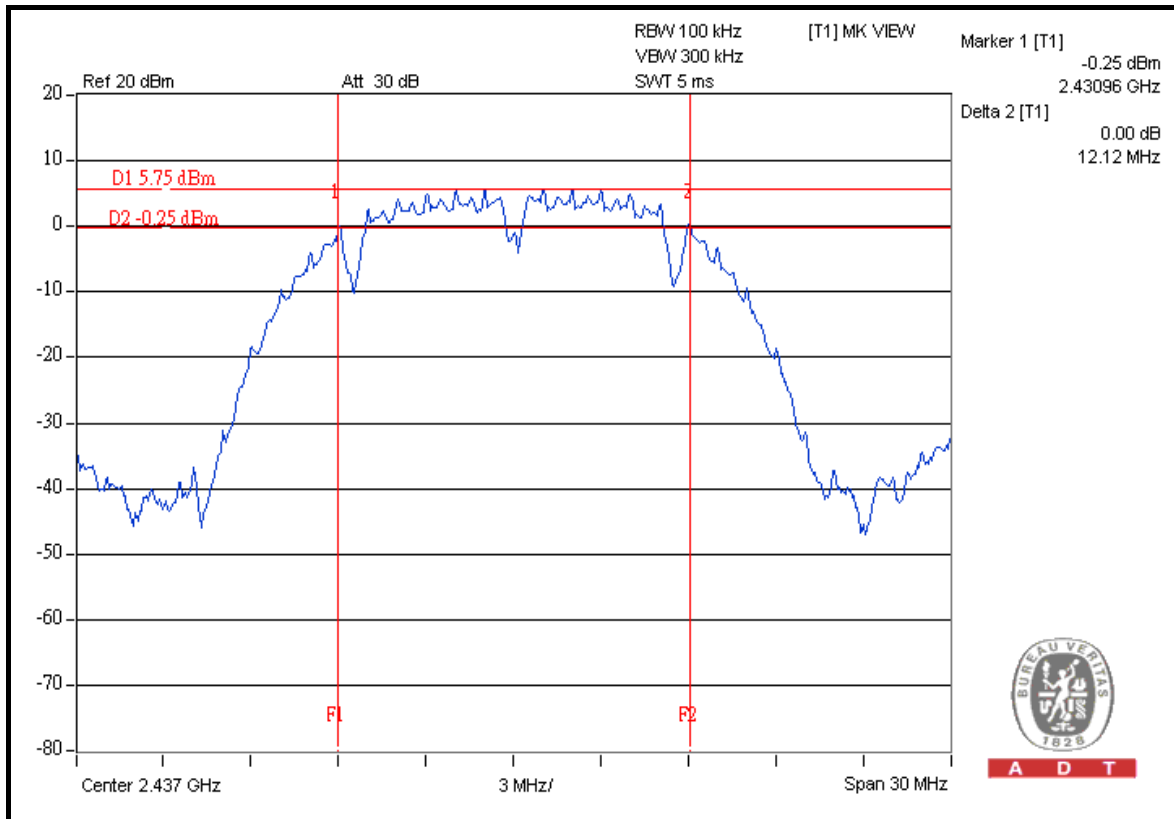



A D T

CH 11

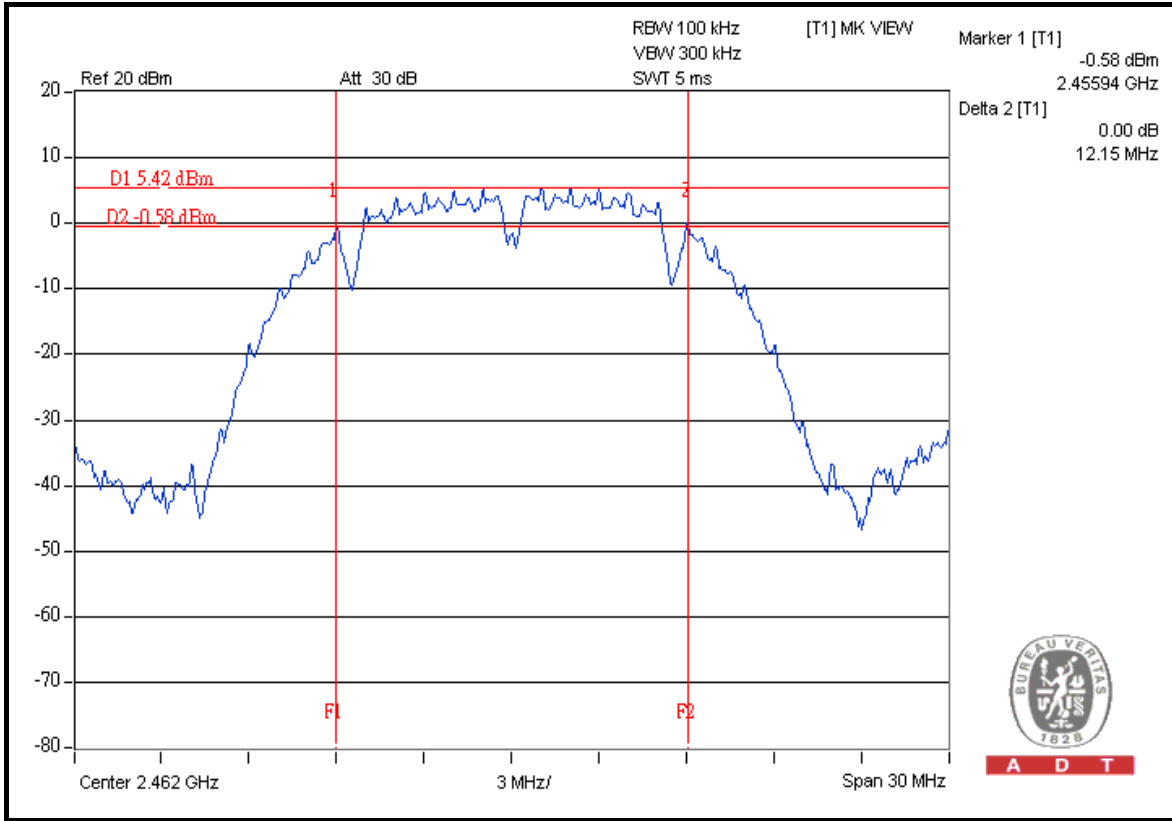

FOR CHAIN 1: CH 1

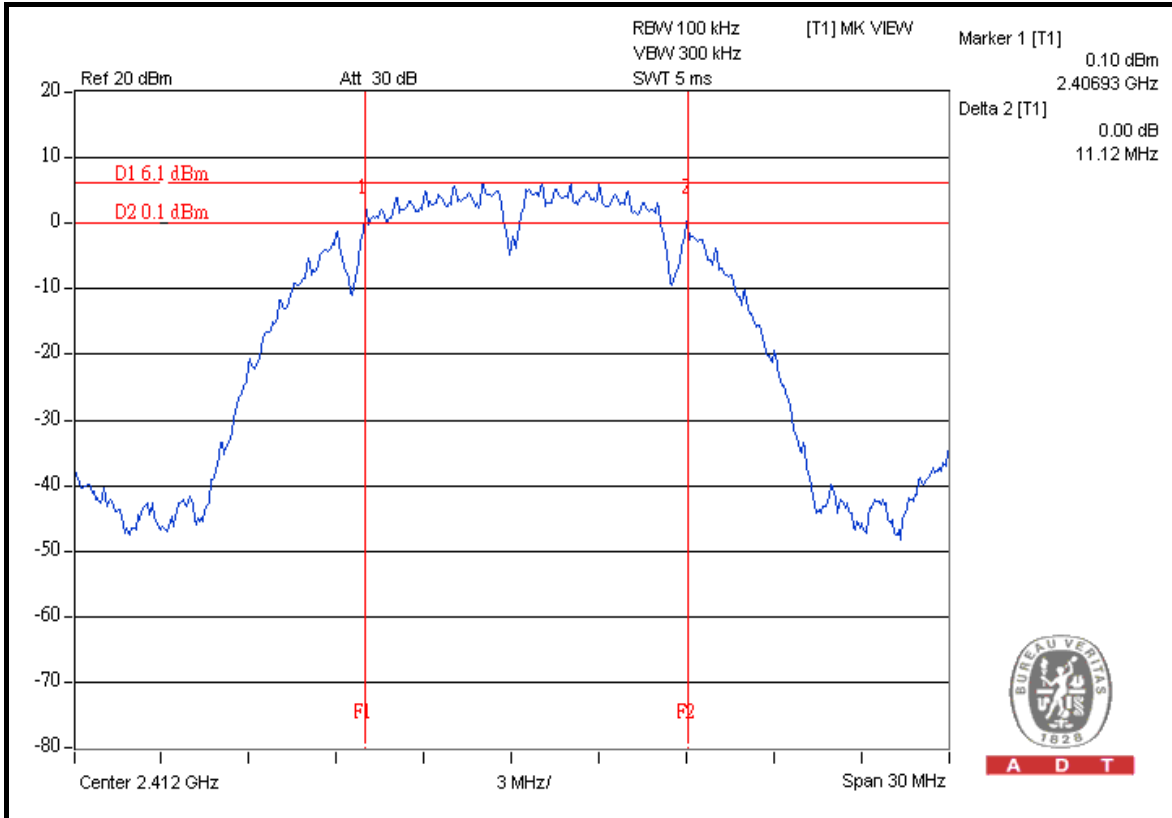



A D T

CH 6

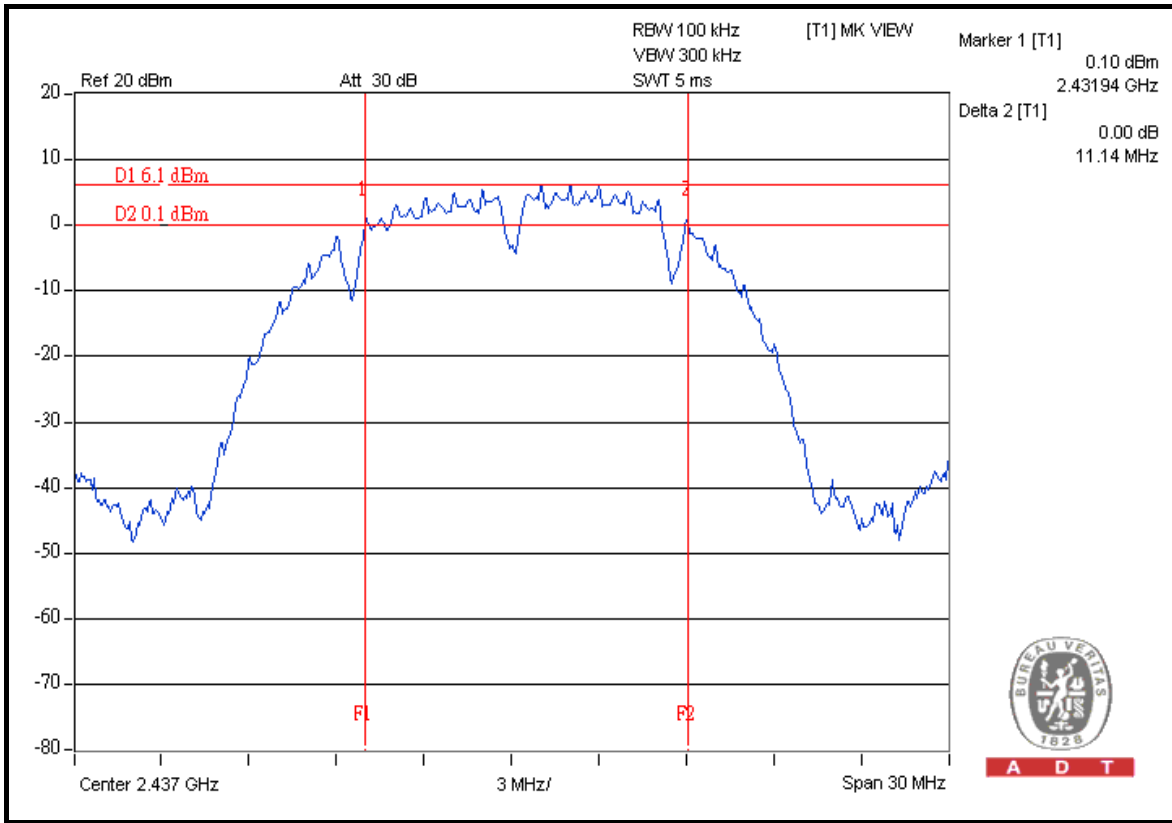

CH 11

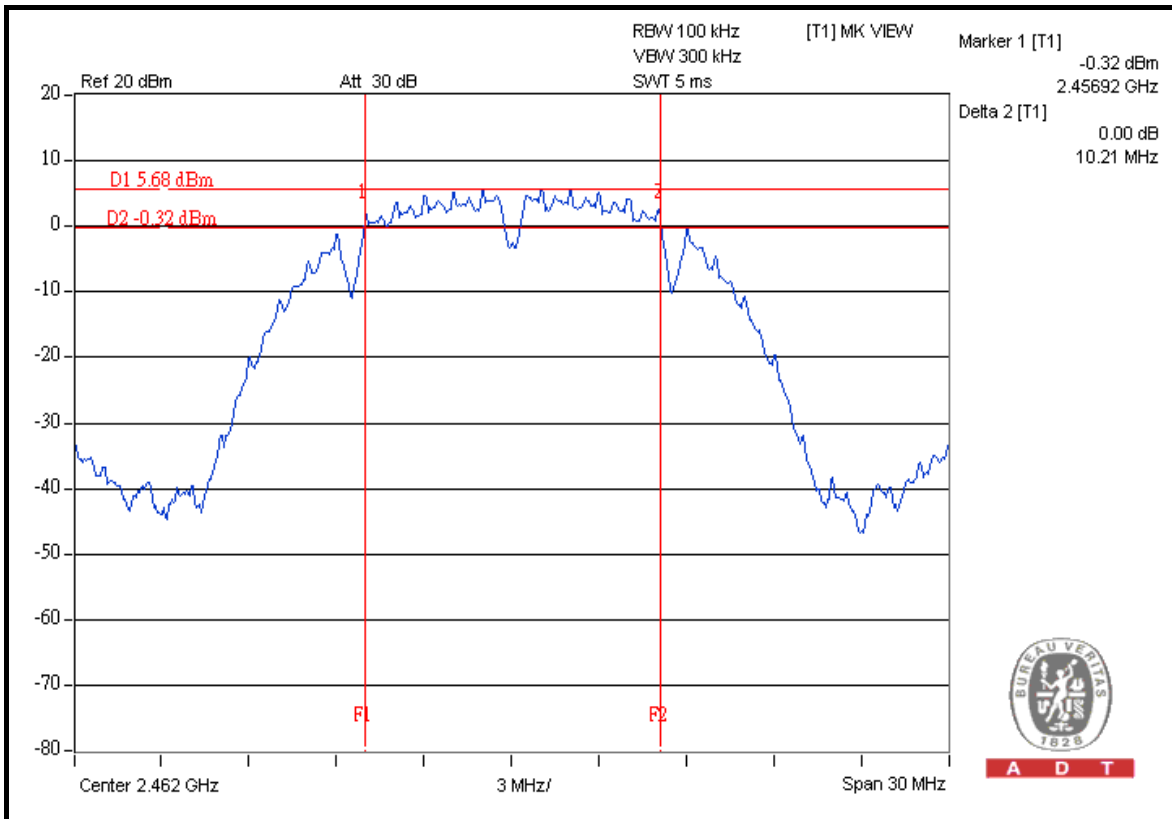



A D T

802.11g OFDM MODULATION

MODULATION TYPE	BPSK	TRANSFER RATE	6.0Mbps
INPUT POWER	120Vac, 60Hz	ENVIRONMENTAL CONDITIONS	24 deg.C, 64 %RH, 1009 hPa
TESTED BY	Lori Chiu		

CHANNEL	CHANNEL FREQUENCY (MHz)	6dB BANDWIDTH (MHz)		MINIMUM LIMIT (MHz)	PASS / FAIL
		CHAIN 0	CHAIN 1		
1	2412	16.42	16.39	0.5	PASS
6	2437	16.39	16.46	0.5	PASS
11	2462	16.43	16.47	0.5	PASS



A D T

FOR CHAIN 0: CH 1

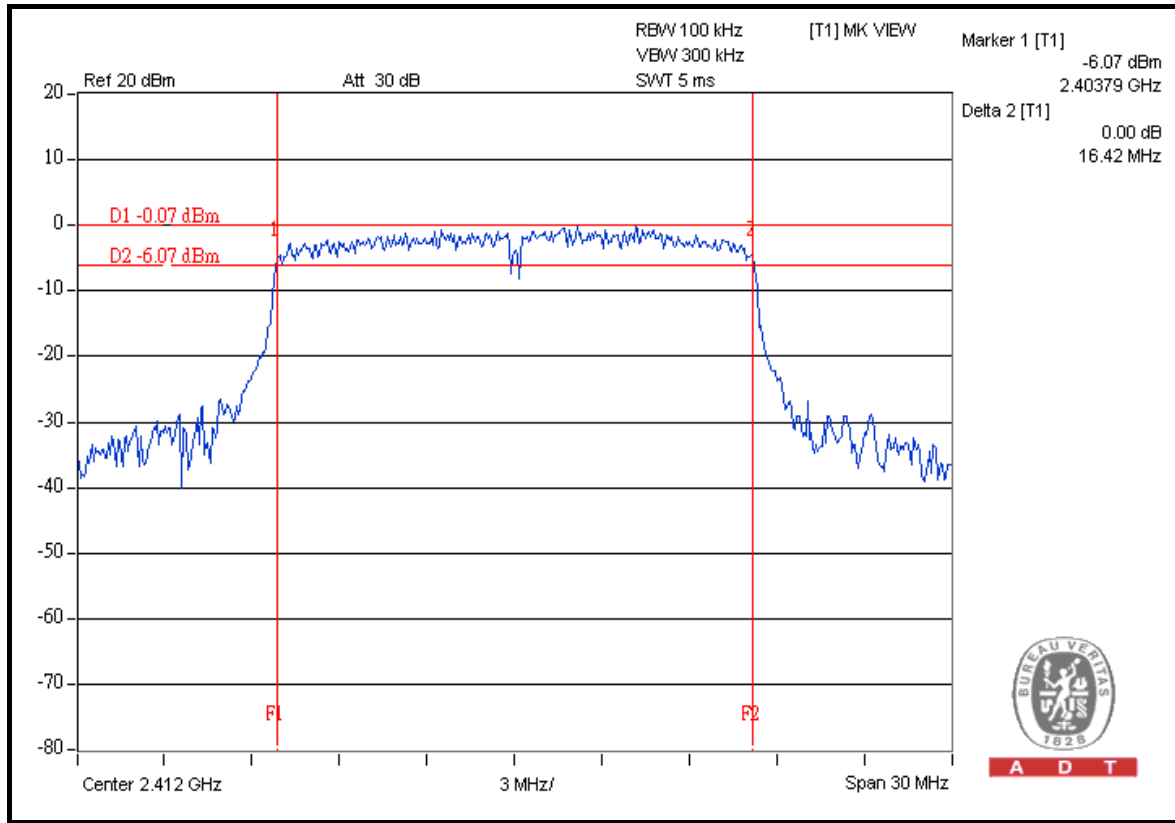

A D T

CH 6

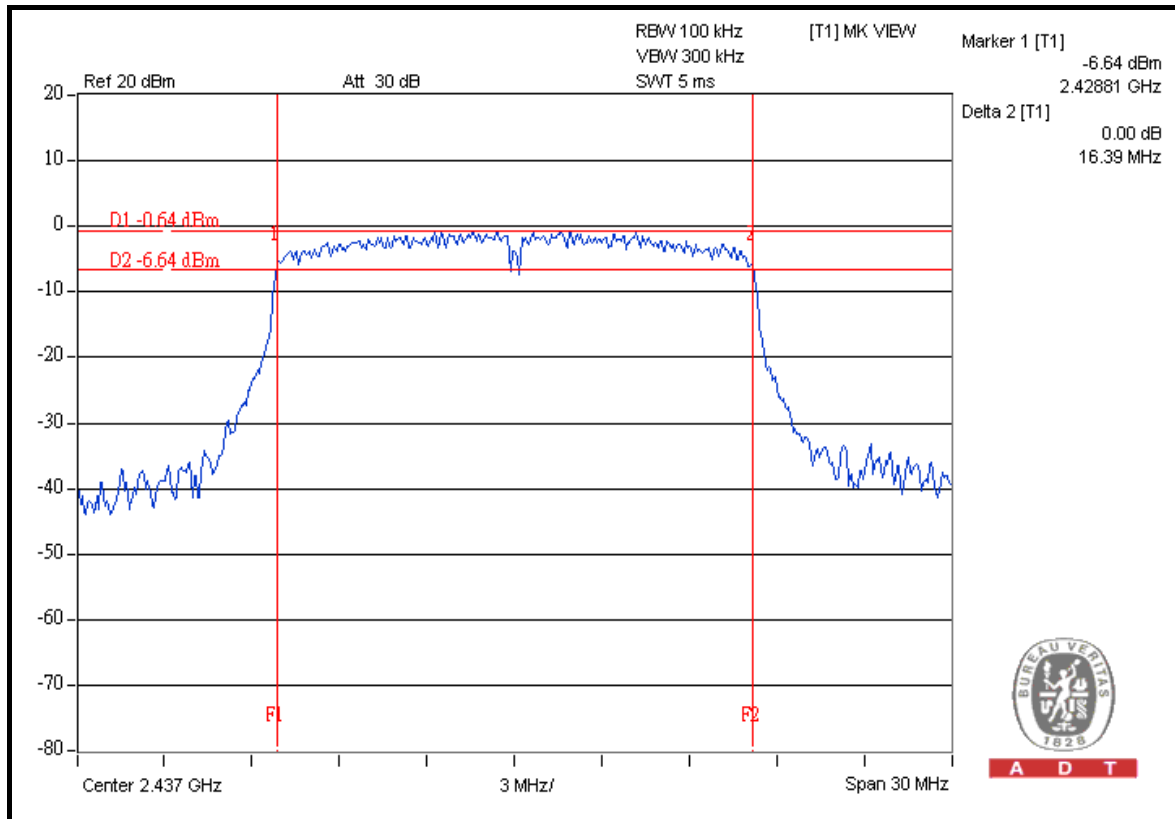

A D T



A D T

CH 11

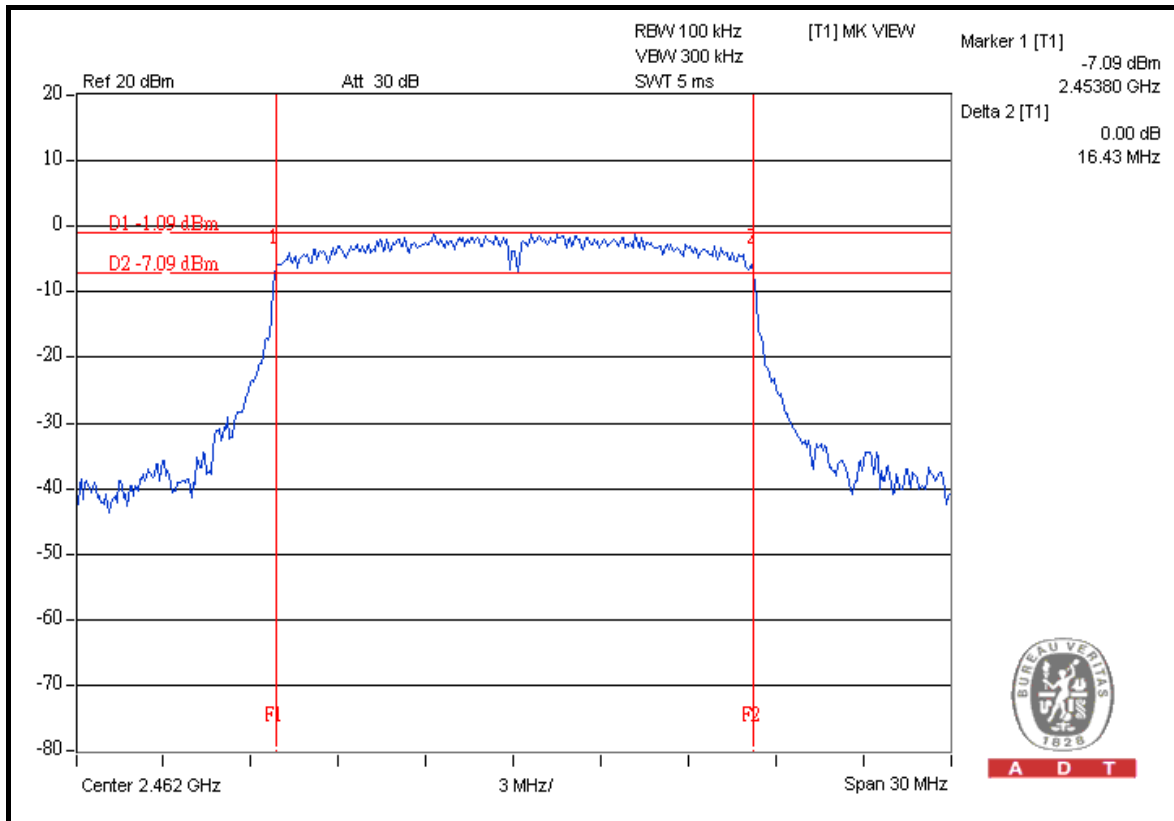

FOR CHAIN 1: CH 1

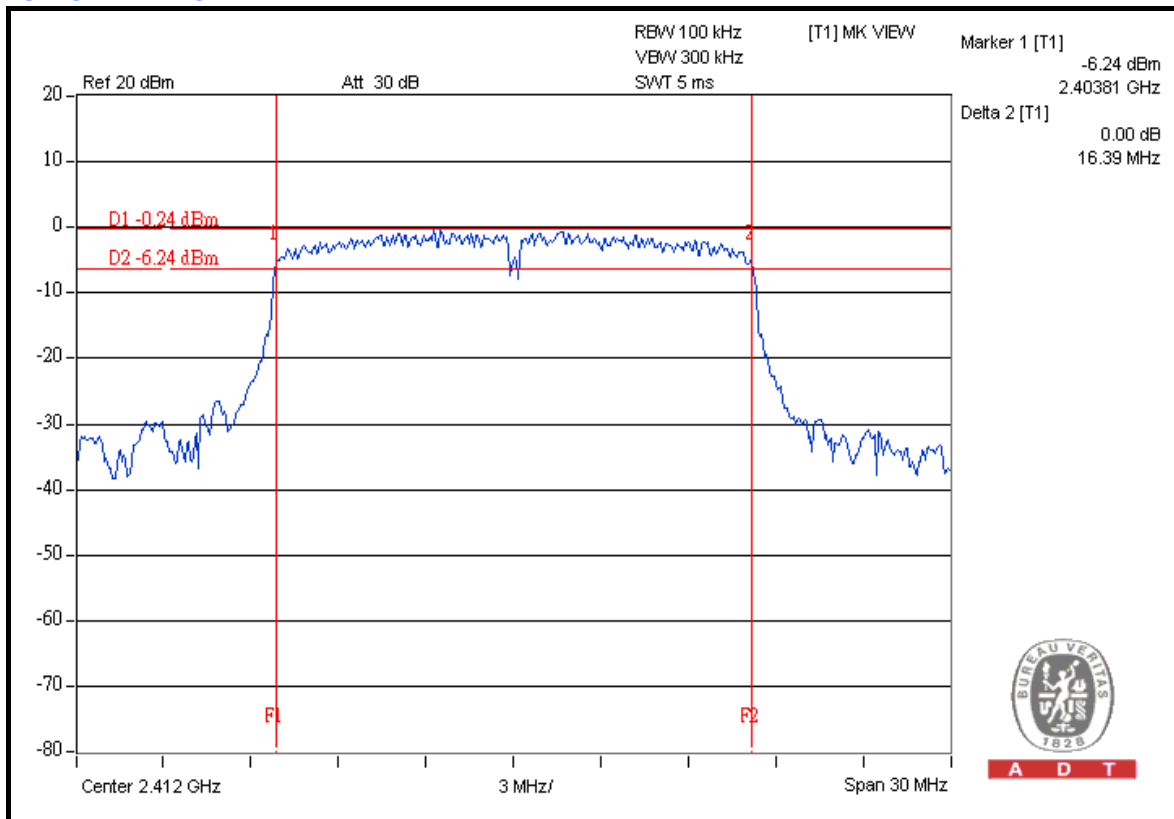



A D T

CH 6

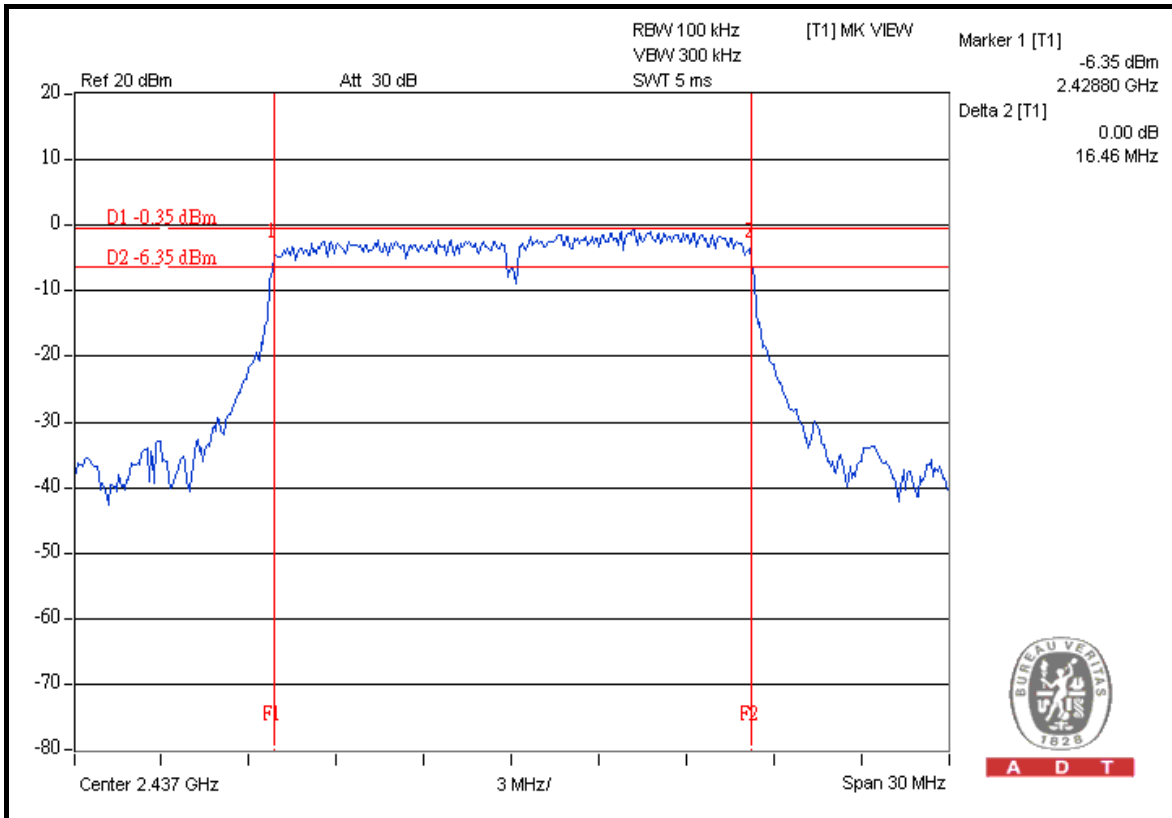

CH 11

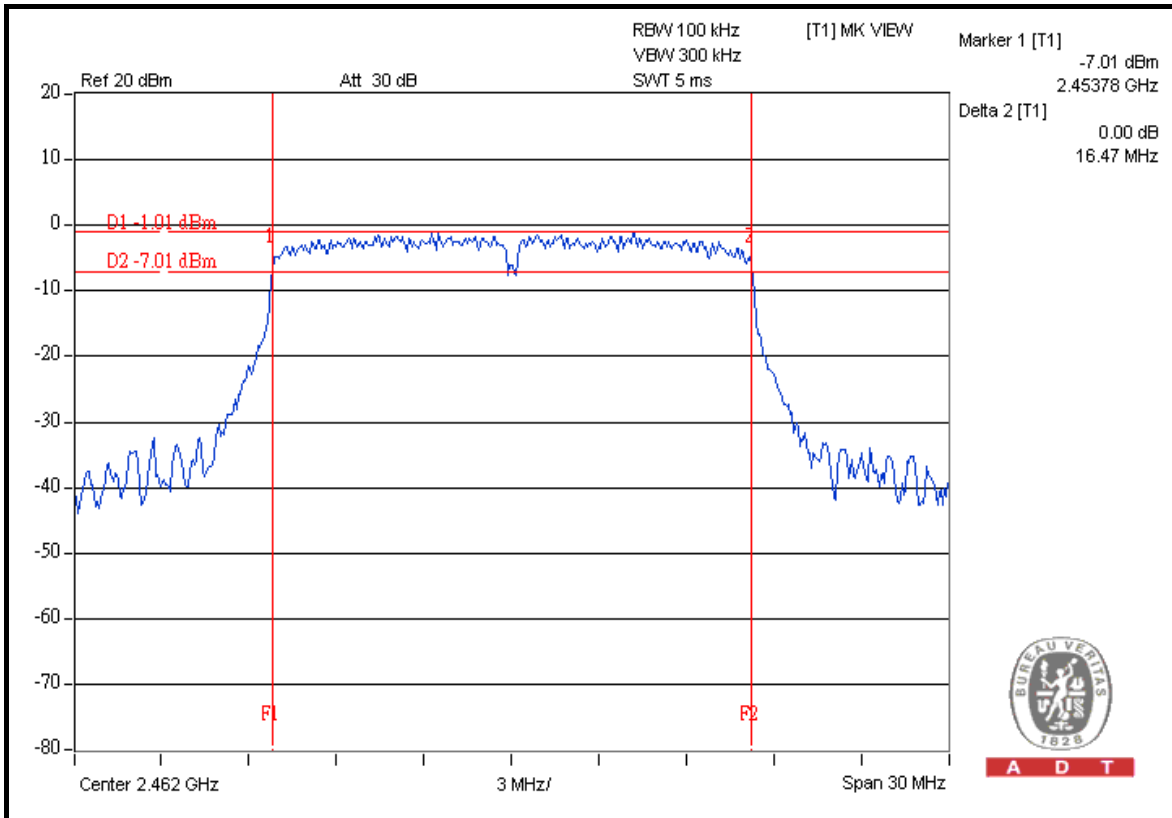



A D T

DRAFT 802.11n (20MHz) OFDM MODULATION

MODULATION TYPE	BPSK	TRANSFER RATE	7.2Mbps
INPUT POWER	120Vac, 60Hz	ENVIRONMENTAL CONDITIONS	24 deg.C, 64 %RH, 1009 hPa
TESTED BY	Lori Chiu		

CHANNEL	CHANNEL FREQUENCY (MHz)	6dB BANDWIDTH (MHz)		MINIMUM LIMIT (MHz)	PASS / FAIL
		CHAIN 0	CHAIN 1		
1	2412	16.61	17.57	0.5	PASS
6	2437	17.02	17.25	0.5	PASS
11	2462	17.23	16.85	0.5	PASS



A D T

FOR CHAIN 0: CH 1

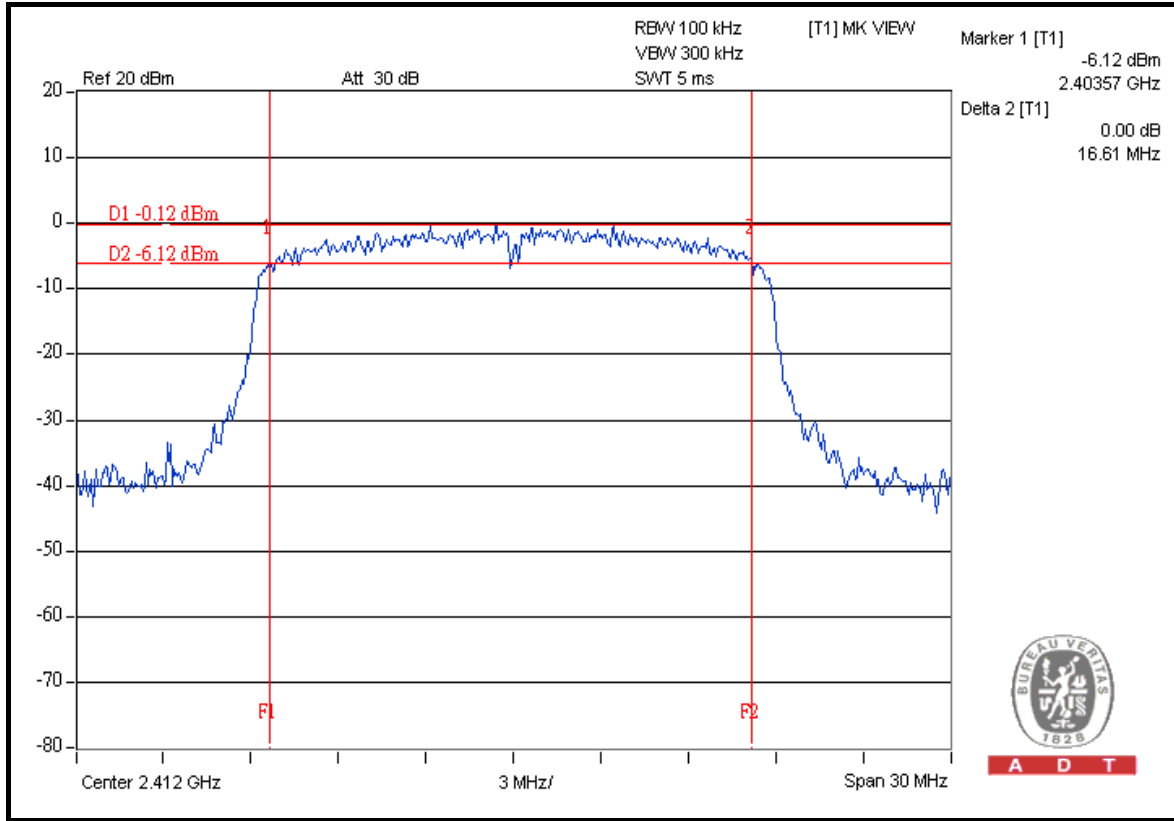

CH 6

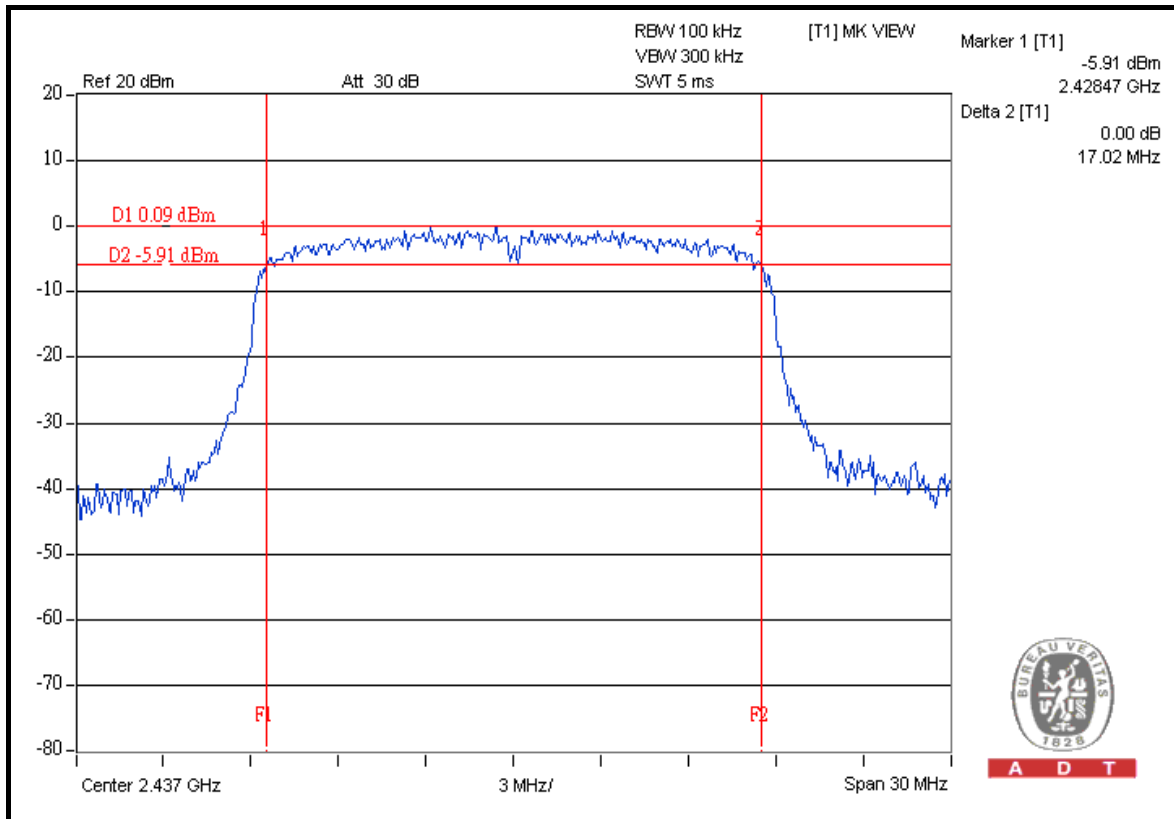



A D T

CH 11

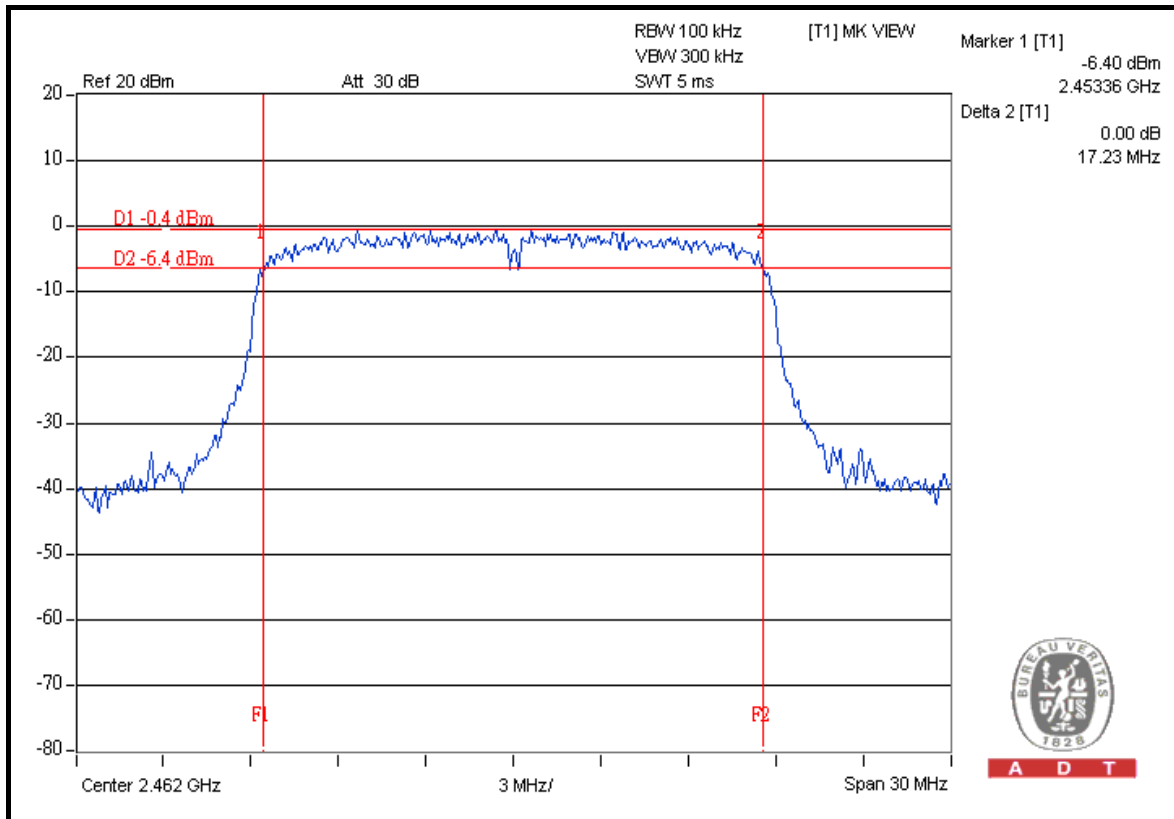

FOR CHAIN 1: CH 1

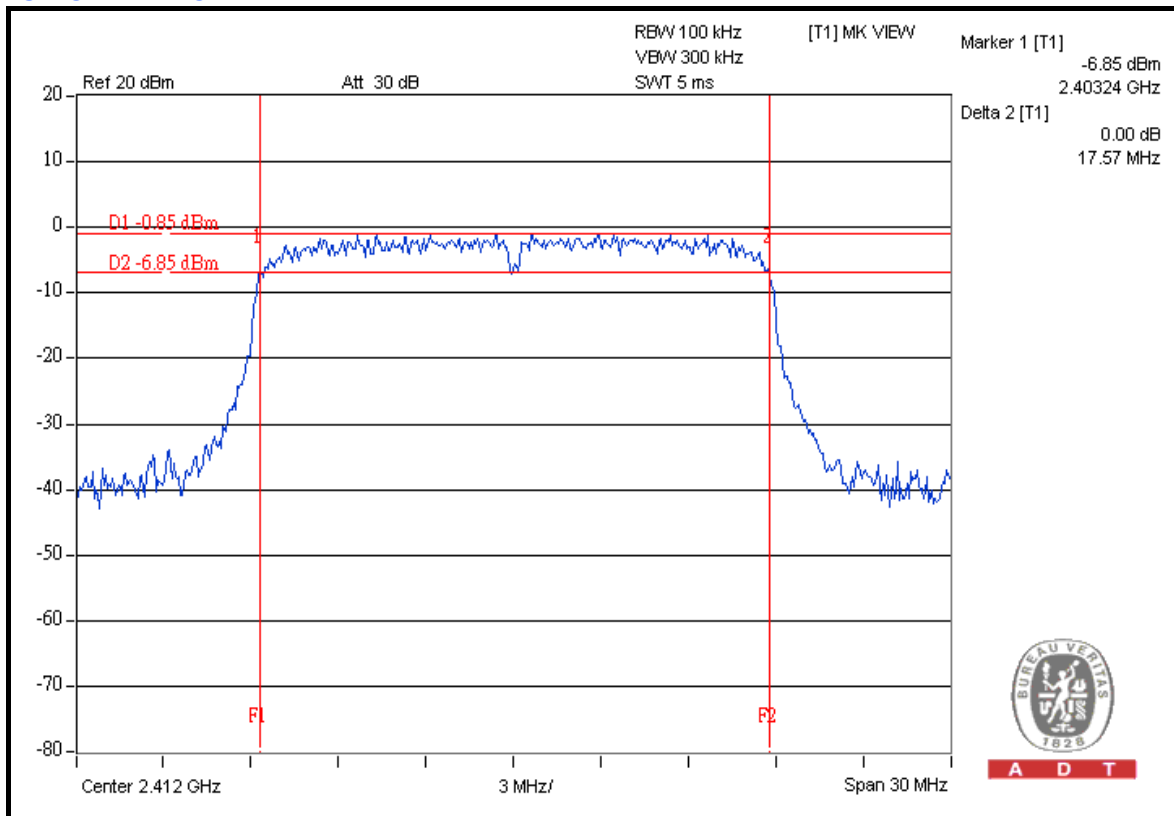



A D T

CH 6

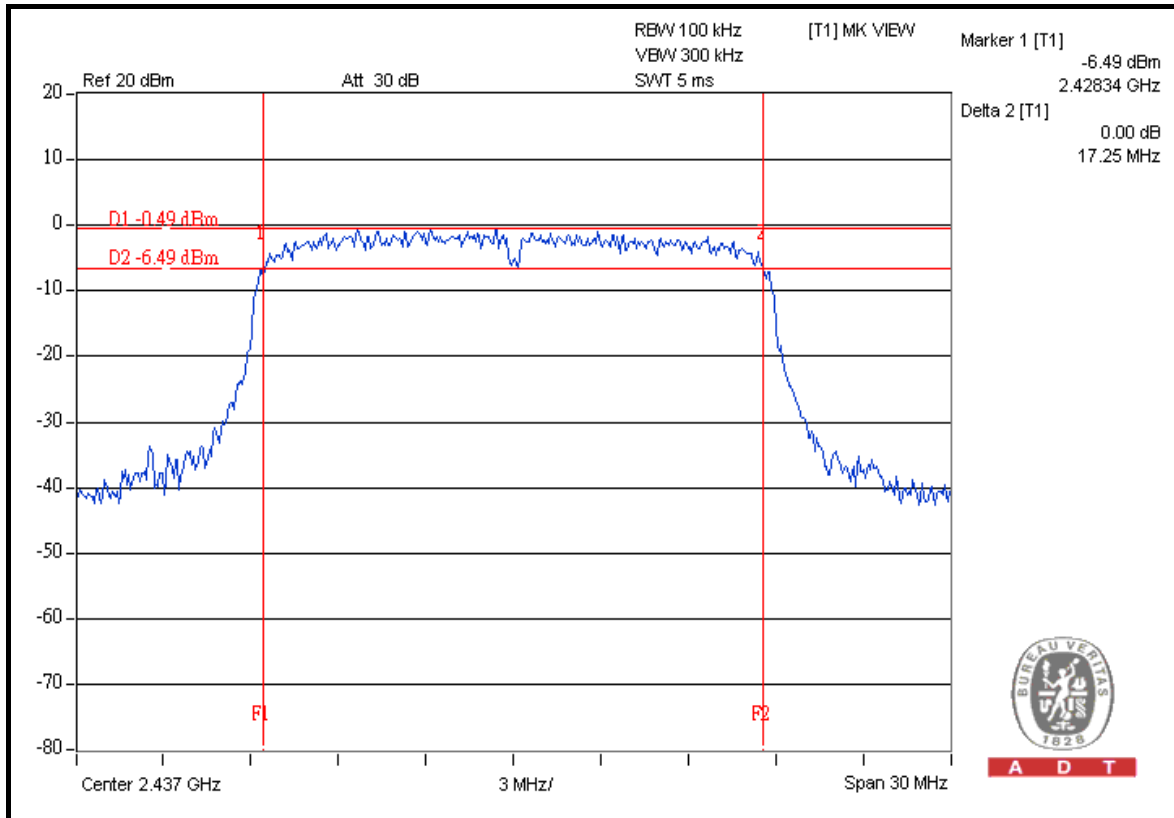

CH 11

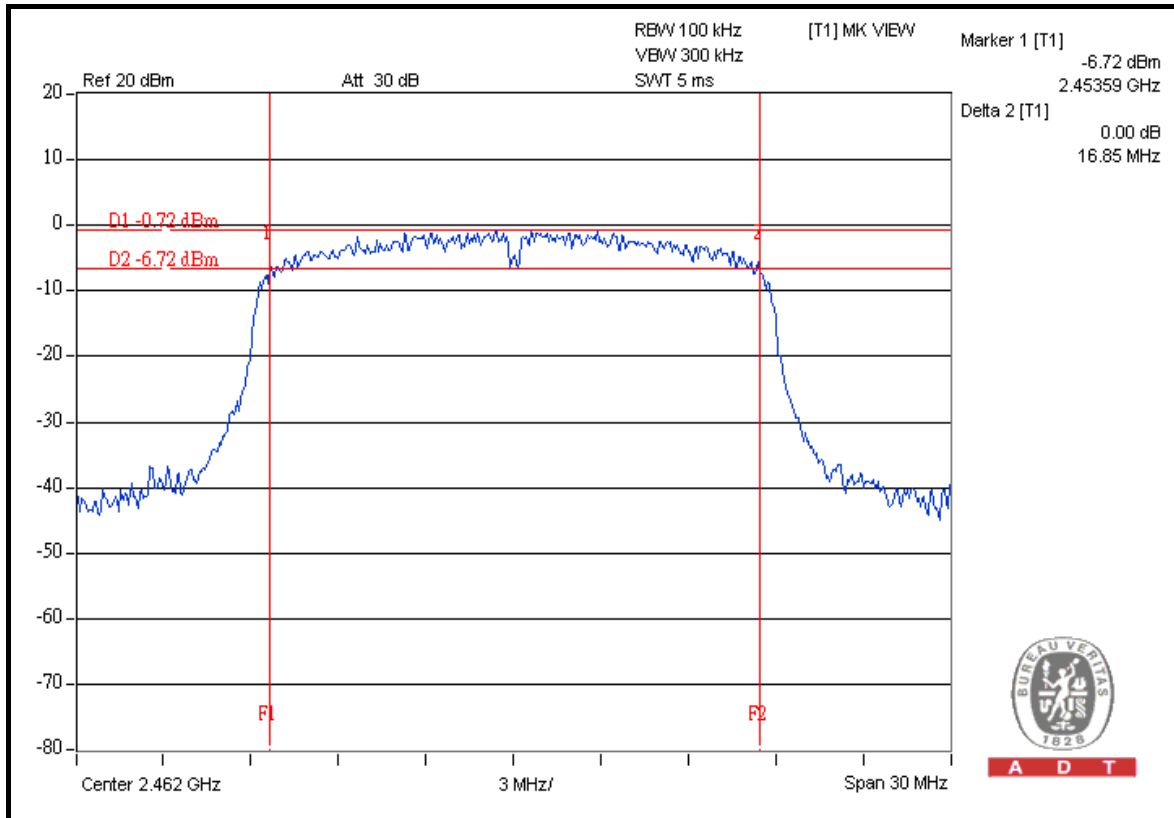



A D T

DRAFT 802.11n (40MHz) OFDM MODULATION

MODULATION TYPE	BPSK	TRANSFER RATE	15.0Mbps
INPUT POWER	120Vac, 60Hz	ENVIRONMENTAL CONDITIONS	24 deg.C, 64 %RH, 1009 hPa
TESTED BY	Lori Chiu		

CHANNEL	CHANNEL FREQUENCY (MHz)	6dB BANDWIDTH (MHz)		MINIMUM LIMIT (MHz)	PASS / FAIL
		CHAIN 0	CHAIN 1		
1	2422	35.59	35.45	0.5	PASS
4	2437	35.99	35.37	0.5	PASS
7	2452	35.76	35.50	0.5	PASS



A D T

FOR CHAIN 0 : CH 1

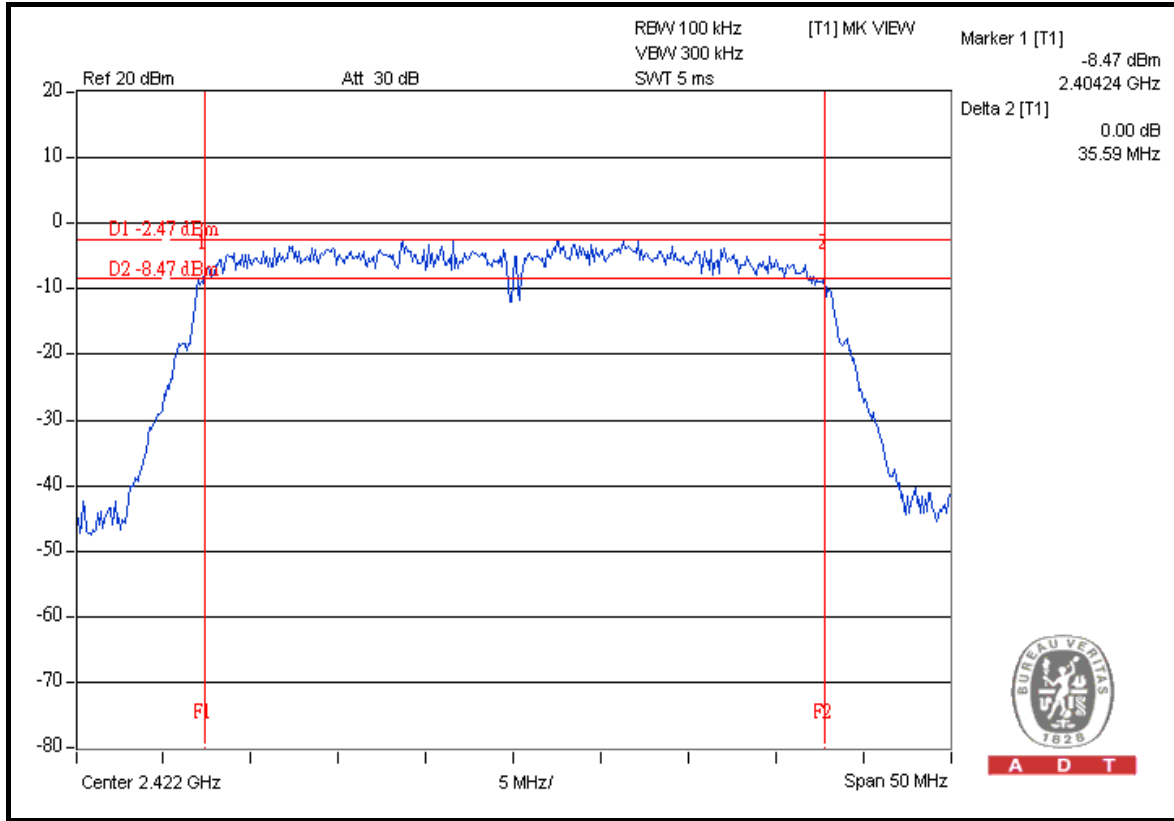

CH 4

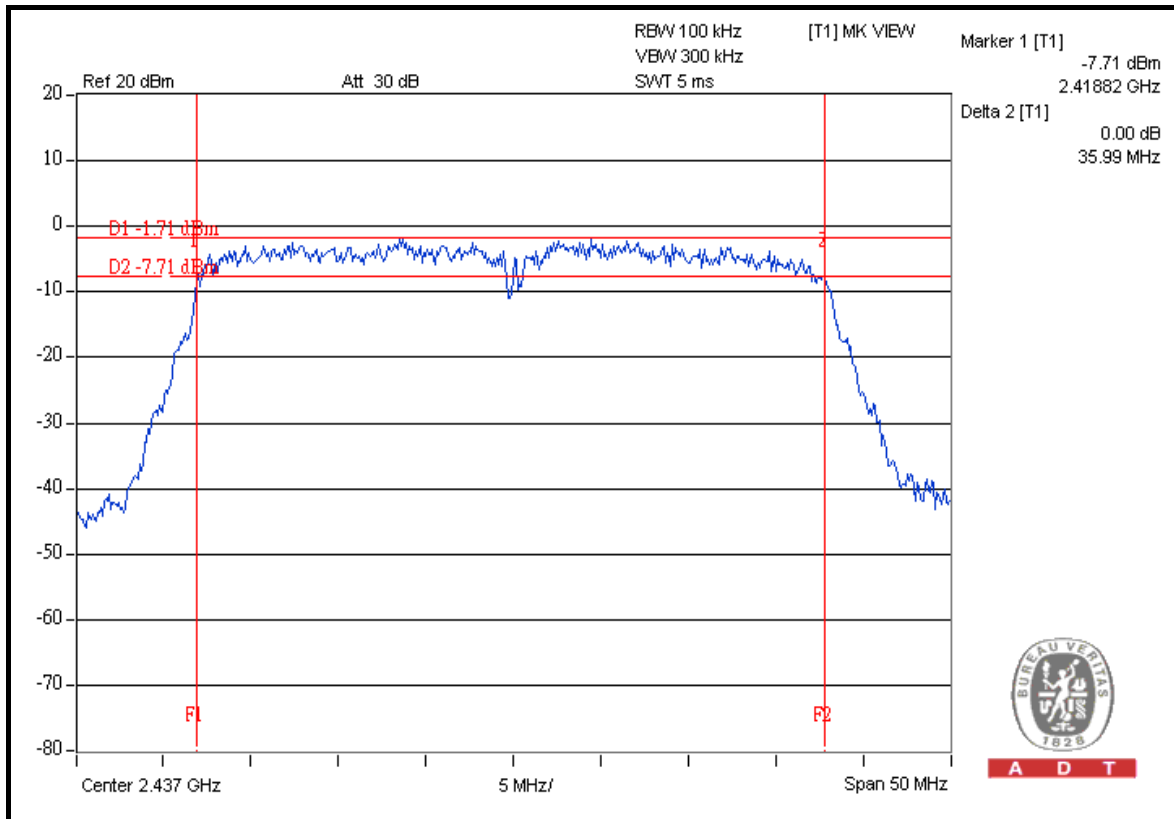



A D T

CH 7

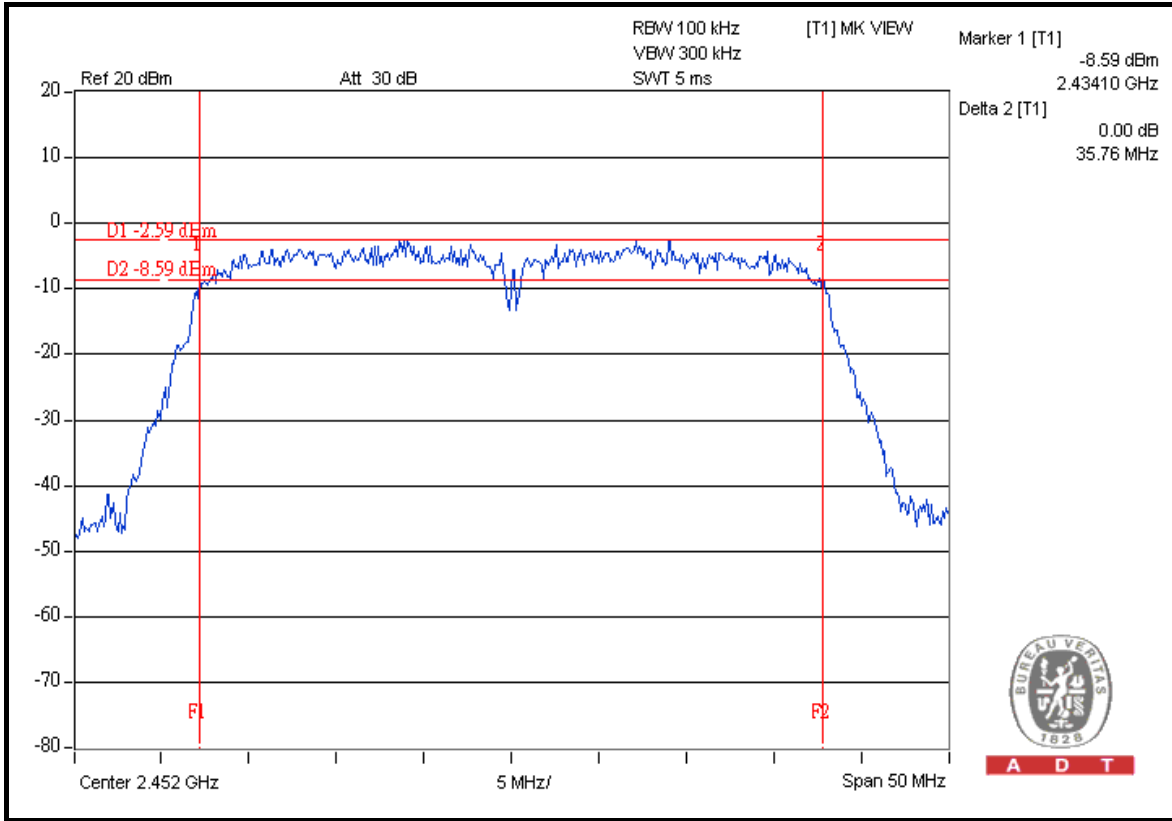

FOR CHAIN 1 : CH 1

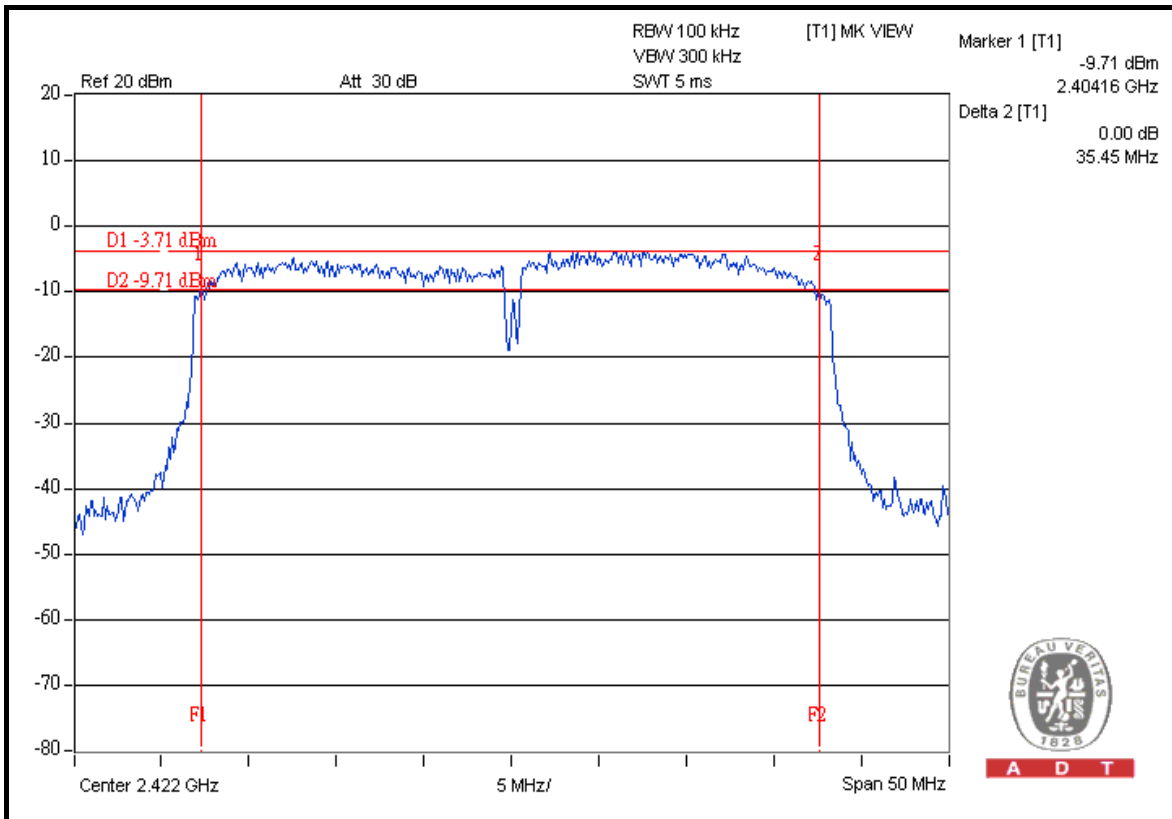



A D T

CH 4

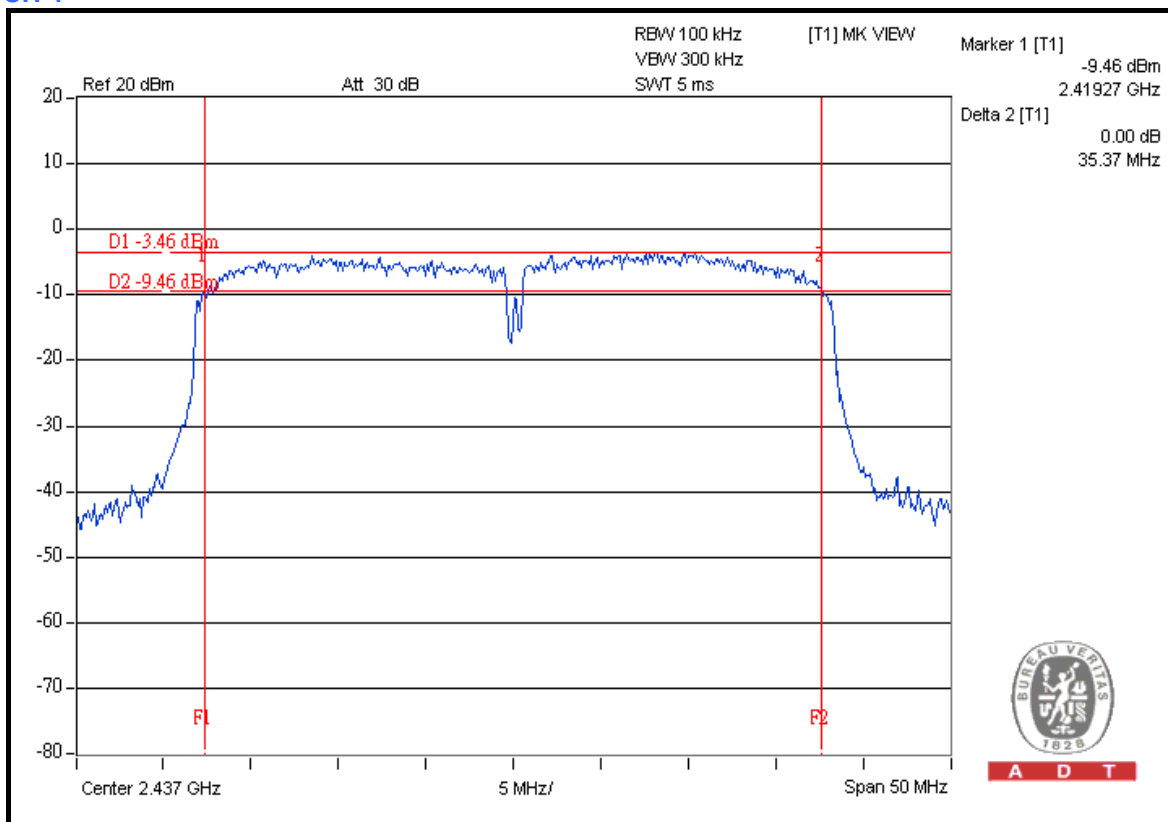

CH 7

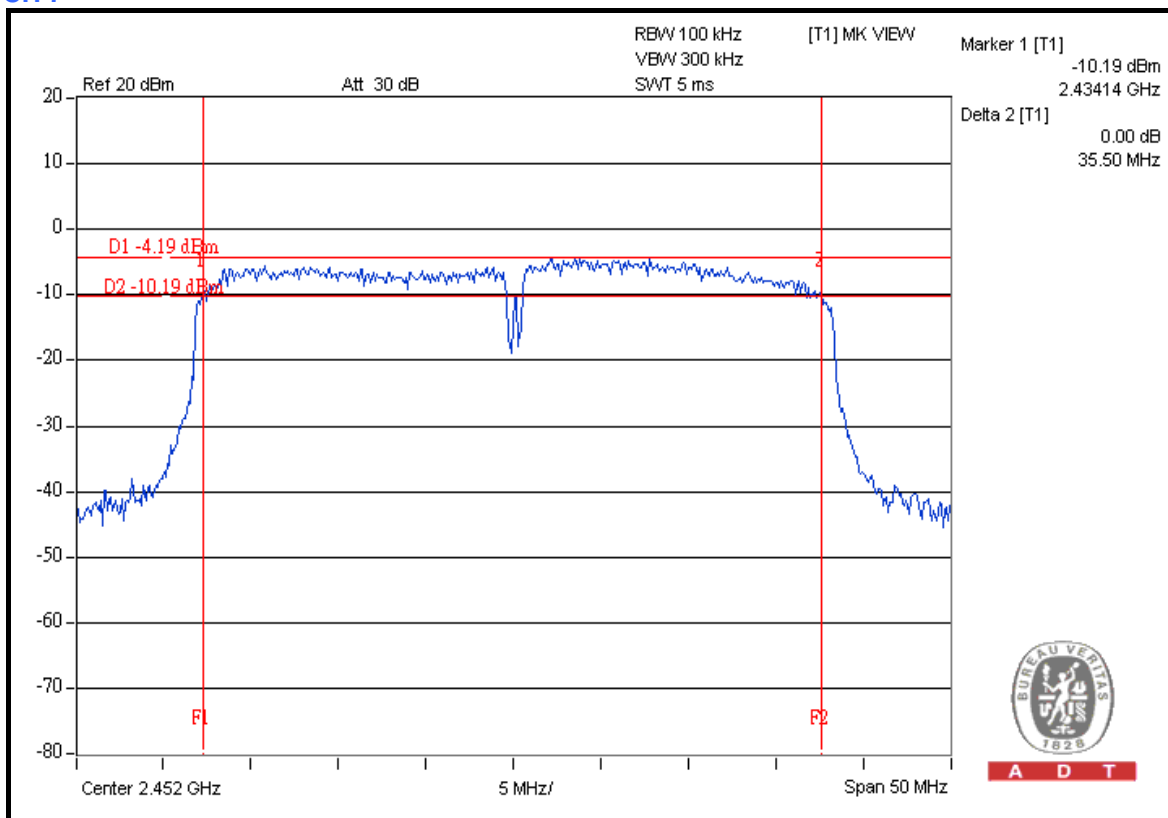



A D T

4.4 MAXIMUM PEAK OUTPUT POWER

4.4.1 LIMITS OF MAXIMUM PEAK OUTPUT POWER MEASUREMENT

The Maximum Peak Output Power Measurement is 30dBm.

4.4.2 INSTRUMENTS

DESCRIPTION & MANUFACTURER	MODEL NO.	SERIAL NO.	DATE OF CALIBRATION	DUE DATE OF CALIBRATION
High Speed Peak Power Meter	ML2495A	0824012	Aug. 10, 2009	Aug. 09, 2010
Power Sensor	MA2411B	0738138	Aug. 10, 2009	Aug. 09, 2010

NOTE:

1. The calibration interval of the above test instruments is 12 months and the calibrations are traceable to NML/ROC and NIST/USA.
2. Measurement Bandwidth of ML2495A is 65MHz greater than 6dB bandwidth of emission.

4.4.3 TEST PROCEDURES

A power sensor was used on the output port of the EUT. A power meter was used to read the response of the power sensor. Record the power level.

4.4.4 DEVIATION FROM TEST STANDARD

No deviation.

4.4.5 TEST SETUP

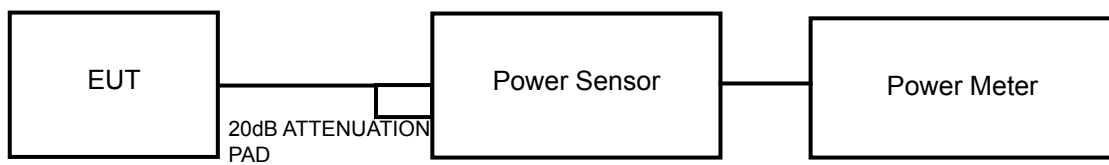

4.4.6 EUT OPERATING CONDITIONS

Same as Item 4.3.6.



A D T

4.4.7 TEST RESULTS

802.11b DSSS MODULATION

MODULATION TYPE	DBPSK	TRANSFER RATE	1.0Mbps
INPUT POWER	120Vac, 60Hz	ENVIRONMENTAL CONDITIONS	24 deg.C, 64 %RH, 1009hPa
TESTED BY	Lori Chiu		

CHAN.	CHAN. FREQ. (MHz)	PEAK POWER OUTPUT (dBm)		TOTAL PEAK POWER (mW)	TOTAL PEAK POWER (dBm)	PEAK POWER LIMIT (dBm)	PASS / FAIL
		CHAIN 0	CHAIN 1				
1	2412	20.27	20.54	219.654	23.42	30	PASS
6	2437	20.58	20.39	223.683	23.50	30	PASS
11	2462	20.14	20.16	207.029	23.16	30	PASS

802.11g OFDM MODULATION

MODULATION TYPE	BPSK	TRANSFER RATE	6.0Mbps
INPUT POWER	120Vac, 60Hz	ENVIRONMENTAL CONDITIONS	24 deg.C, 64 %RH, 1009hPa
TESTED BY	Lori Chiu		

CHAN.	CHAN. FREQ. (MHz)	PEAK POWER OUTPUT (dBm)		TOTAL PEAK POWER (mW)	TOTAL PEAK POWER (dBm)	PEAK POWER LIMIT (dBm)	PASS / FAIL
		CHAIN 0	CHAIN 1				
1	2412	23.90	23.91	491.508	26.92	30	PASS
6	2437	23.54	23.75	463.081	26.66	30	PASS
11	2462	23.08	22.98	401.845	26.04	30	PASS



A D T

DRAFT 802.11n (20MHz) OFDM MODULATION

MODULATION TYPE	BPSK	TRANSFER RATE	7.2Mbps
INPUT POWER	120Vac, 60Hz	ENVIRONMENTAL CONDITIONS	24 deg.C, 64 %RH, 1009hPa
TESTED BY	Lori Chiu		

CHAN.	CHAN. FREQ. (MHz)	PEAK POWER OUTPUT (dBm)		TOTAL PEAK POWER (mW)	TOTAL PEAK POWER (dBm)	PEAK POWER LIMIT (dBm)	PASS / FAIL
		CHAIN 0	CHAIN 1				
1	2412	23.12	22.77	394.351	25.96	30	PASS
6	2437	23.21	23.12	414.527	26.18	30	PASS
11	2462	22.89	22.76	383.335	25.84	30	PASS

DRAFT 802.11n (40MHz) OFDM MODULATION

MODULATION TYPE	BPSK	TRANSFER RATE	15.0Mbps
INPUT POWER	120Vac, 60Hz	ENVIRONMENTAL CONDITIONS	24 deg.C, 64 %RH, 1009hPa
TESTED BY	Lori Chiu		

CHAN.	CHAN. FREQ. (MHz)	PEAK POWER OUTPUT (dBm)		TOTAL PEAK POWER (mW)	TOTAL PEAK POWER (dBm)	PEAK POWER LIMIT (dBm)	PASS / FAIL
		CHAIN 0	CHAIN 1				
1	2422	22.64	22.81	374.639	25.74	30	PASS
4	2437	23.26	23.02	412.283	26.15	30	PASS
7	2452	22.36	22.24	339.681	25.31	30	PASS

4.5 POWER SPECTRAL DENSITY MEASUREMENT

4.5.1 LIMITS OF POWER SPECTRAL DENSITY MEASUREMENT

The Maximum of Power Spectral Density Measurement is 8dBm.

4.5.2 TEST INSTRUMENTS

DESCRIPTION & MANUFACTURER	MODEL NO.	SERIAL NO.	DATE OF CALIBRATION	DUE DATE OF CALIBRATION
SPECTRUM ANALYZER R&S	FSP40	100040	Jul. 07, 2009	Jul. 06, 2010

NOTE: The calibration interval of the above test instruments is 12 months and the calibrations are traceable to NML/ROC and NIST/USA.

4.5.3 TEST PROCEDURE

The transmitter output was connected to the spectrum analyzer through an attenuator, the bandwidth of the fundamental frequency was measured with the spectrum analyzer using 3kHz RBW and 30kHz VBW, set sweep time = span/3kHz. The power spectral density was measured and recorded.

The sweep time is allowed to be longer than span/3kHz for a full response of the mixer in the spectrum analyzer.

4.5.4 DEVIATION FROM TEST STANDARD

No deviation.

4.5.5 TEST SETUP

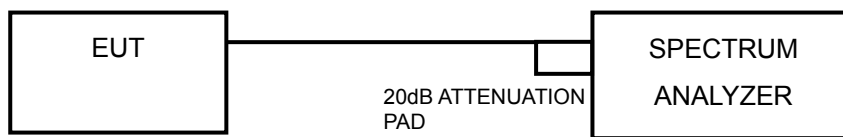

4.5.6 EUT OPERATING CONDITION

Same as Item 4.3.6



A D T

4.5.7 TEST RESULTS

802.11b DSSS MODULATION

MODULATION TYPE	DBPSK	TRANSFER RATE	1.0Mbps
INPUT POWER	120Vac, 60Hz	ENVIRONMENTAL CONDITIONS	24 deg.C, 64 %RH, 1009hPa
TESTED BY	Lori Chiu		

CHAN.	CHAN. FREQ. (MHz)	RF POWER LEVEL IN 3kHz BW (dBm)		TOTAL POWER DENSITY (mW)	TOTAL POWER DENSITY (dBm)	MAX. LIMIT (dBm)	PASS / FAIL
		CHAIN 0	CHAIN 1				
1	2412	-7.66	-9.91	0.273	-5.64	8	PASS
6	2437	-7.27	-9.94	0.289	-5.39	8	PASS
11	2462	-7.65	-10.14	0.269	-5.70	8	PASS



A D T

FOR CHAIN 0: CH 1

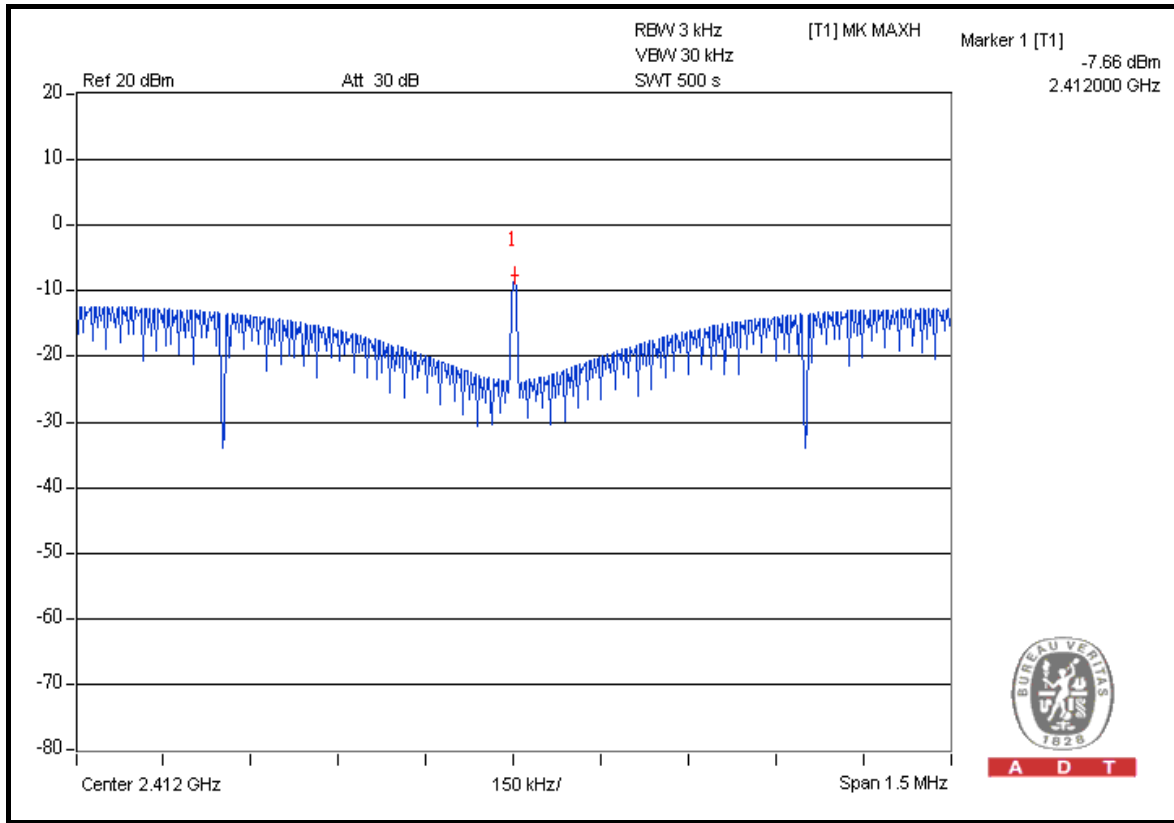

CH 6

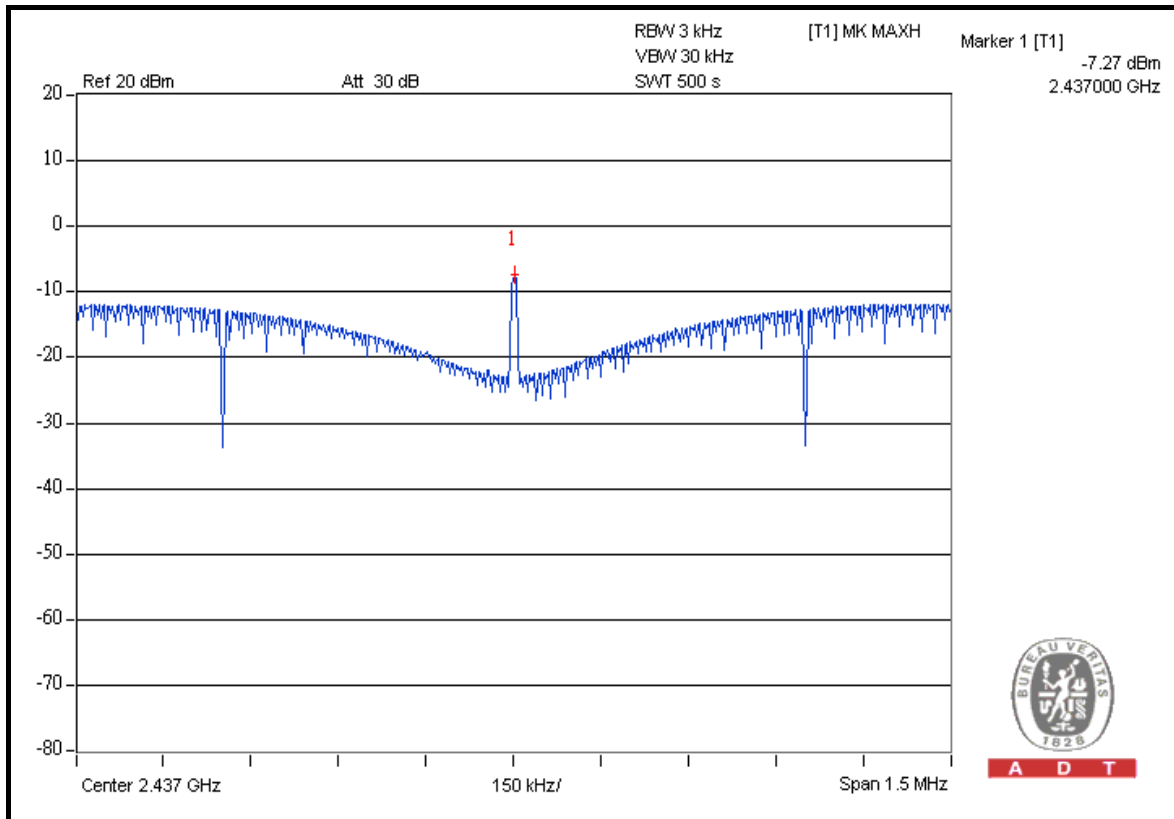



A D T

CH 11

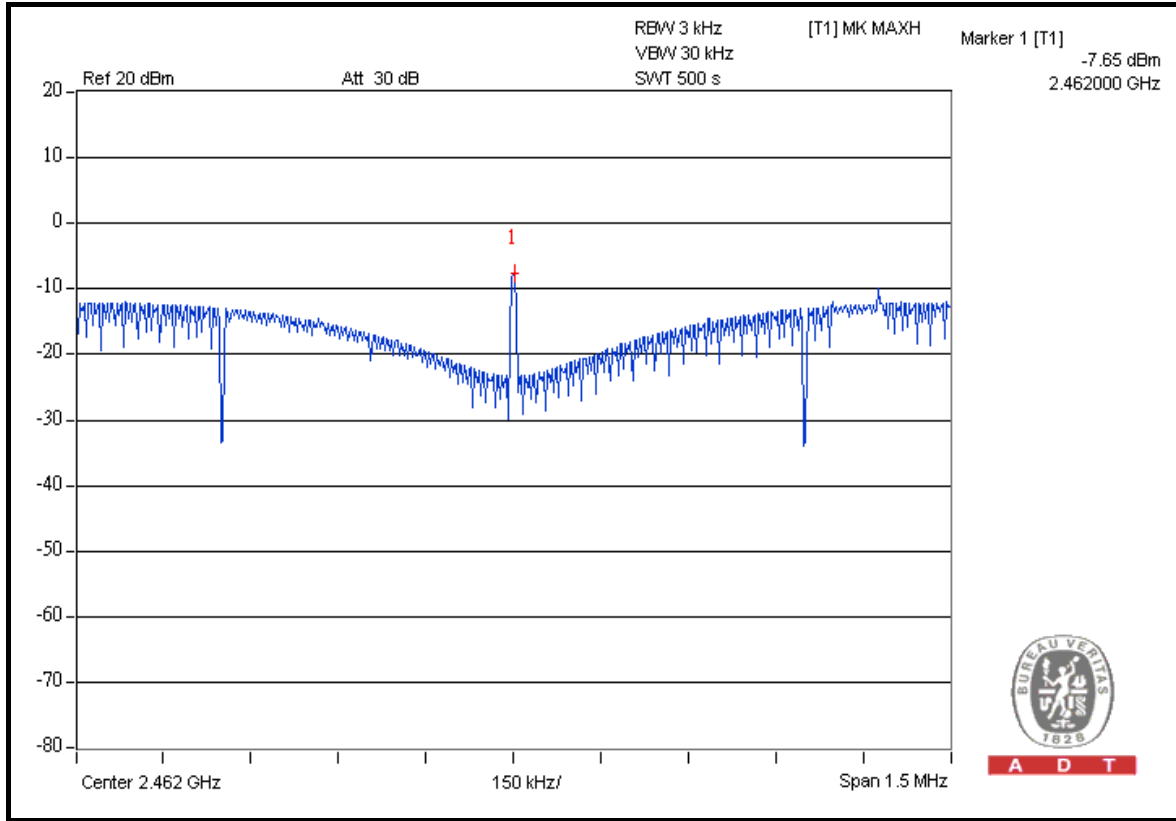

FOR CHAIN 1: CH 1

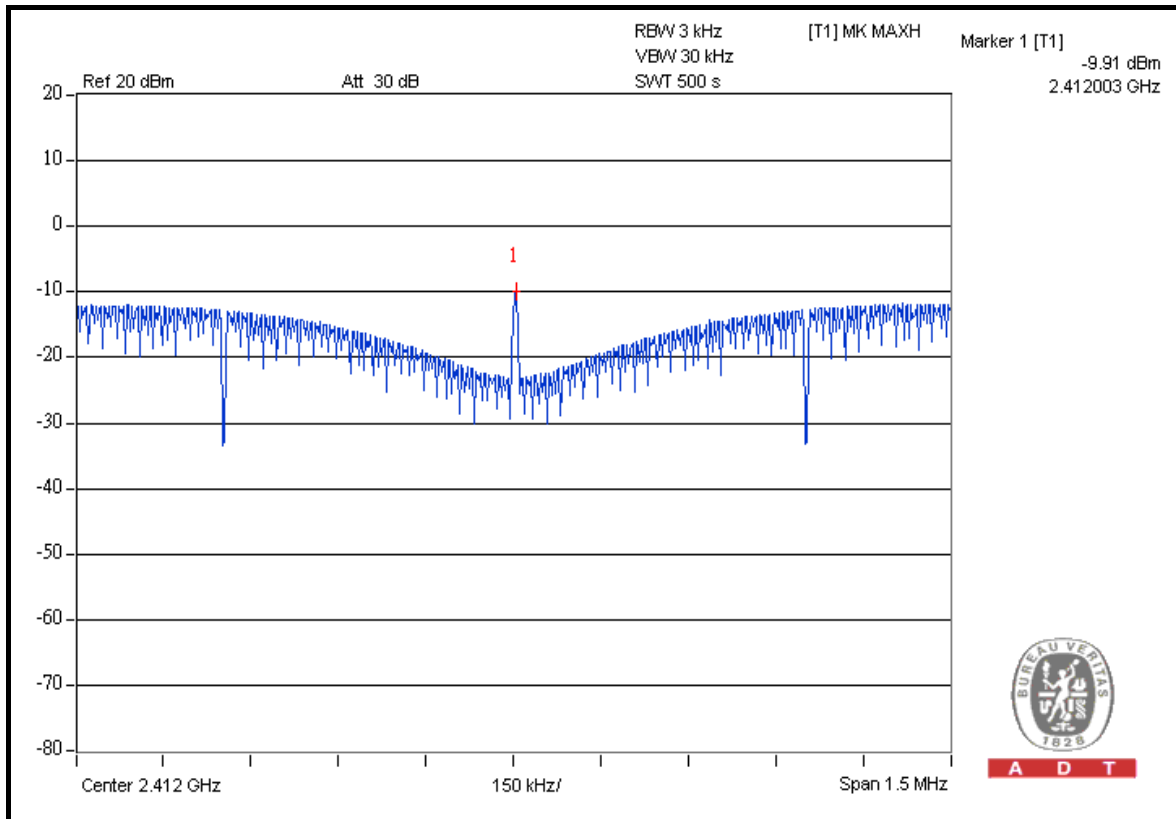



A D T

CH 6

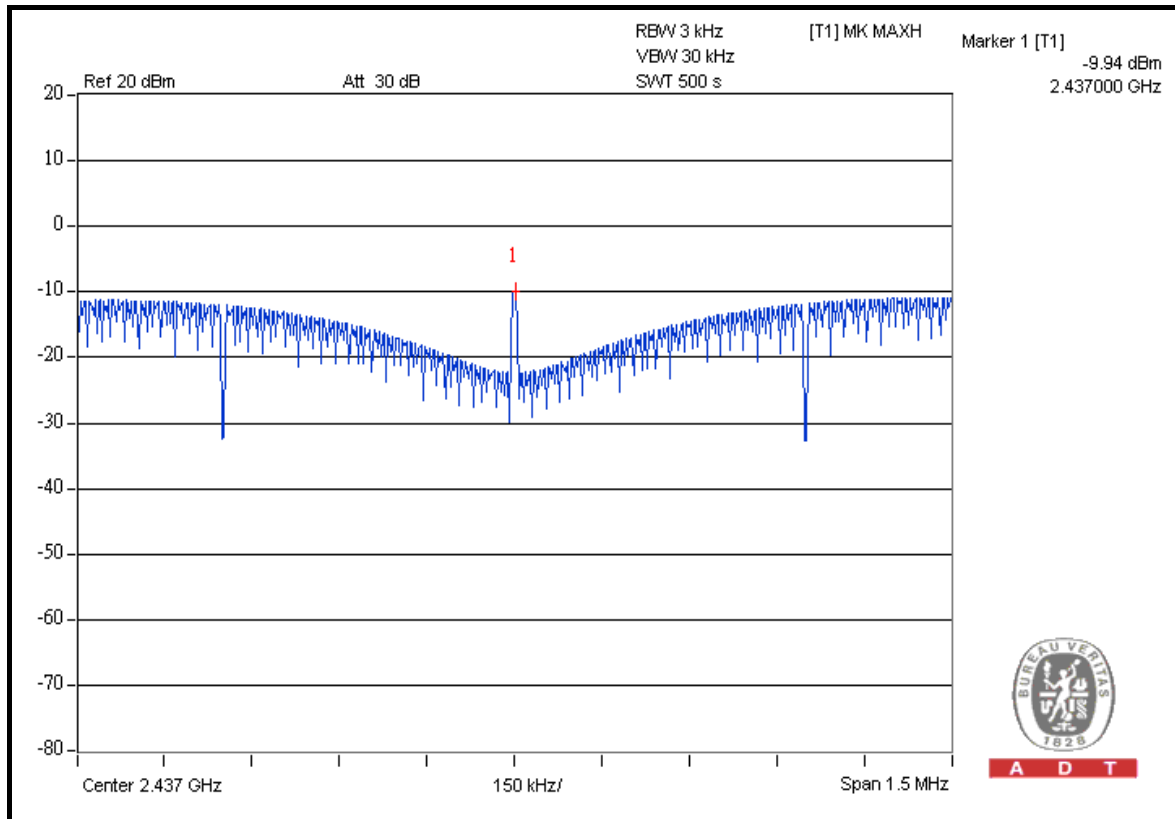

A D T

CH 11

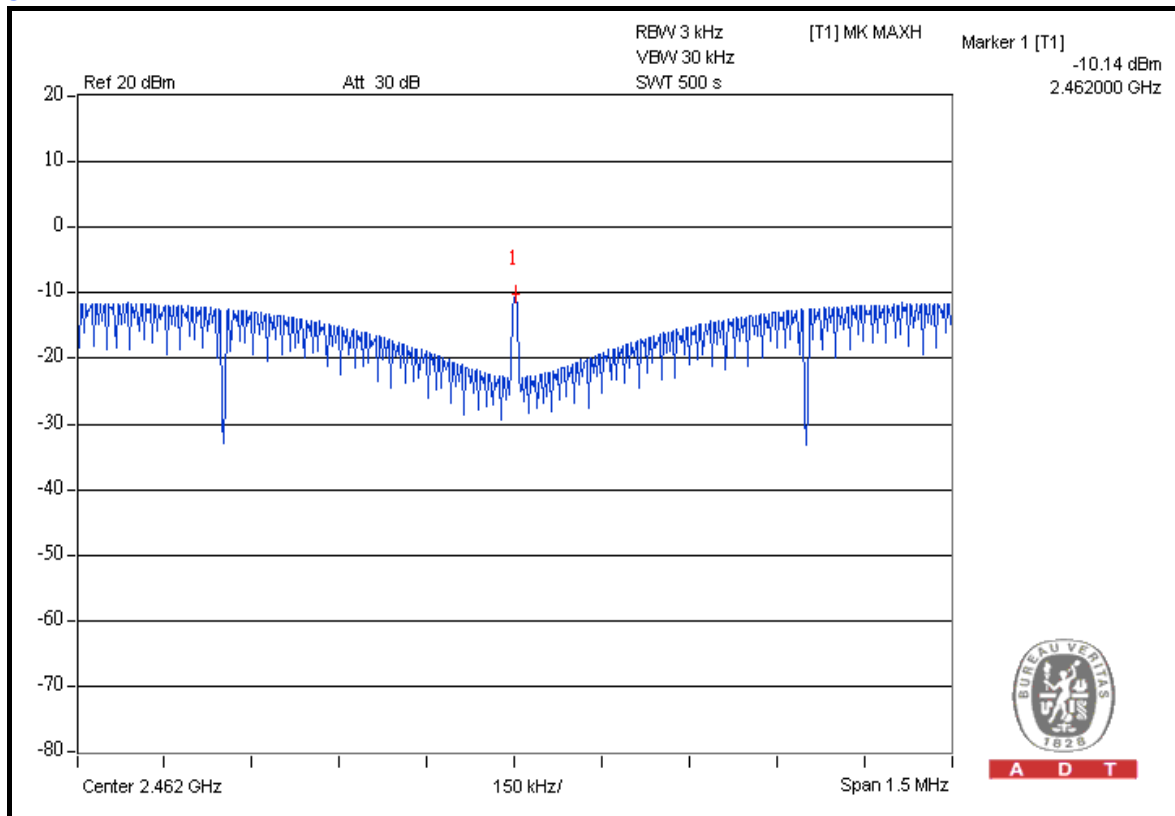

A D T



A D T

802.11g OFDM MODULATION

MODULATION TYPE	BPSK	TRANSFER RATE	6.0Mbps
INPUT POWER	120Vac, 60Hz	ENVIRONMENTAL CONDITIONS	24 deg.C, 64 %RH, 1009hPa
TESTED BY	Lori Chiu		

CHAN.	CHAN. FREQ. (MHz)	RF POWER LEVEL IN 3kHz BW (dBm)		TOTAL POWER DENSITY (mW)	TOTAL POWER DENSITY (dBm)	MAX. LIMIT (dBm)	PASS / FAIL
		CHAIN 0	CHAIN 1				
1	2412	-7.81	-10.50	0.255	-5.93	8	PASS
6	2437	-7.94	-10.51	0.250	-6.02	8	PASS
11	2462	-8.38	-11.19	0.221	-6.56	8	PASS



A D T

FOR CHAIN 0: CH 1

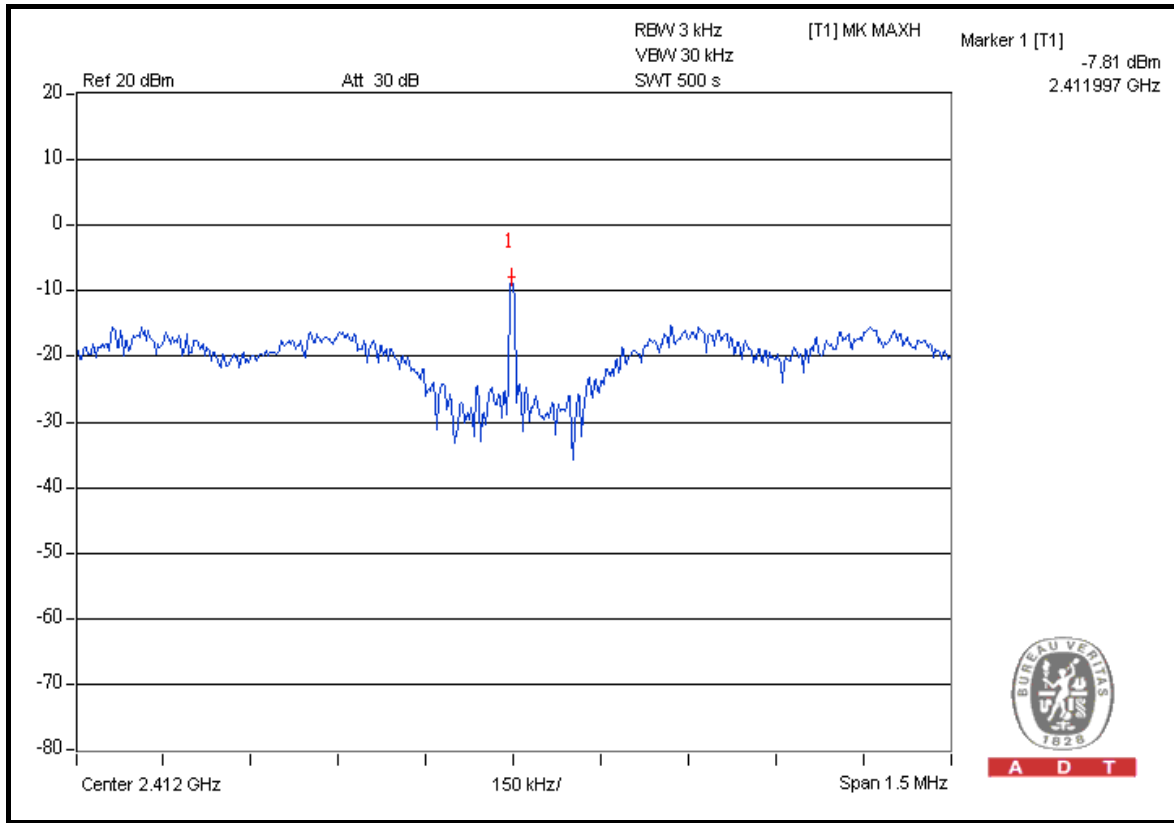

CH 6

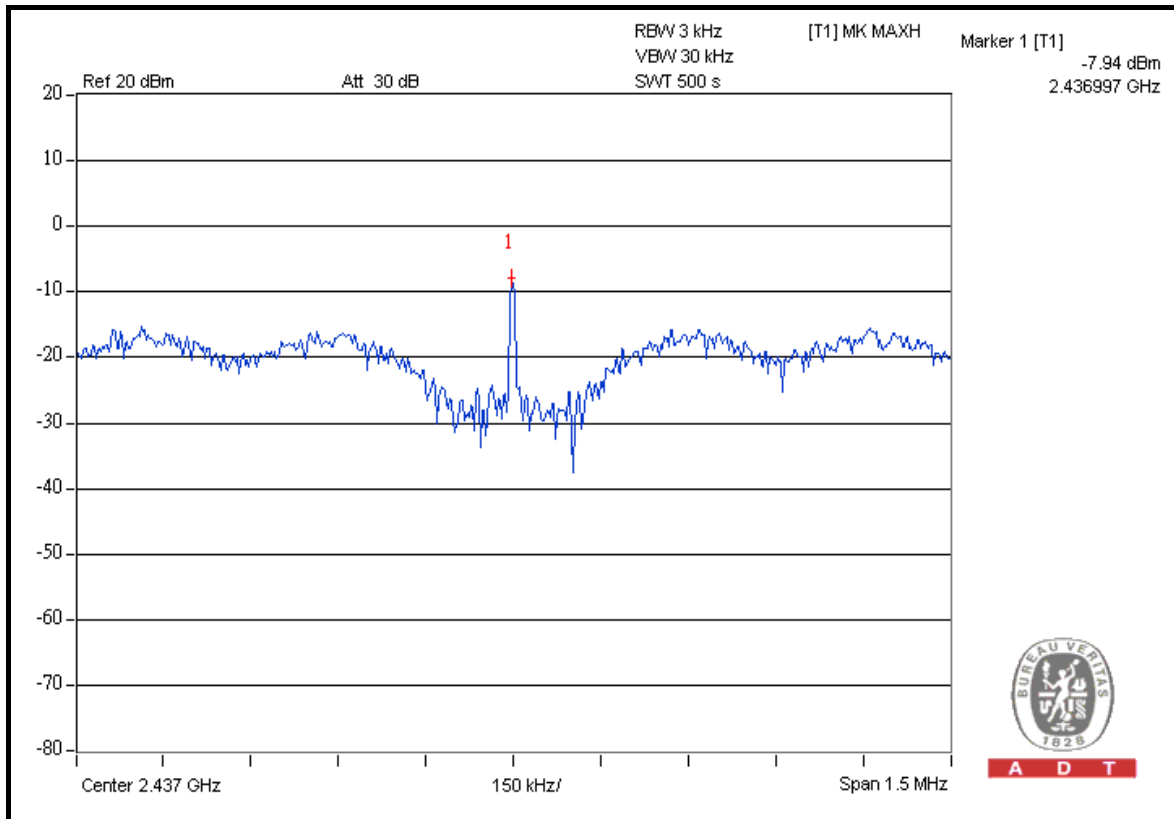



A D T

CH 11

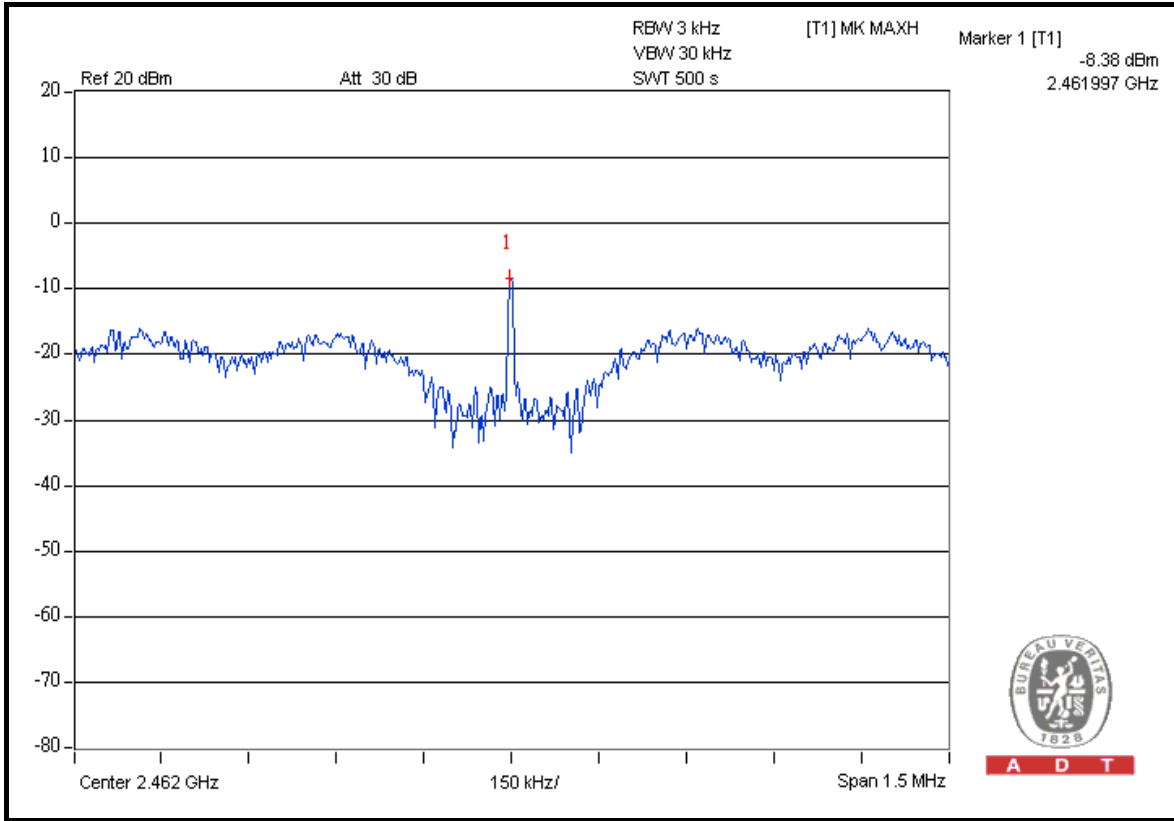

FOR CHAIN 1 : CH 1

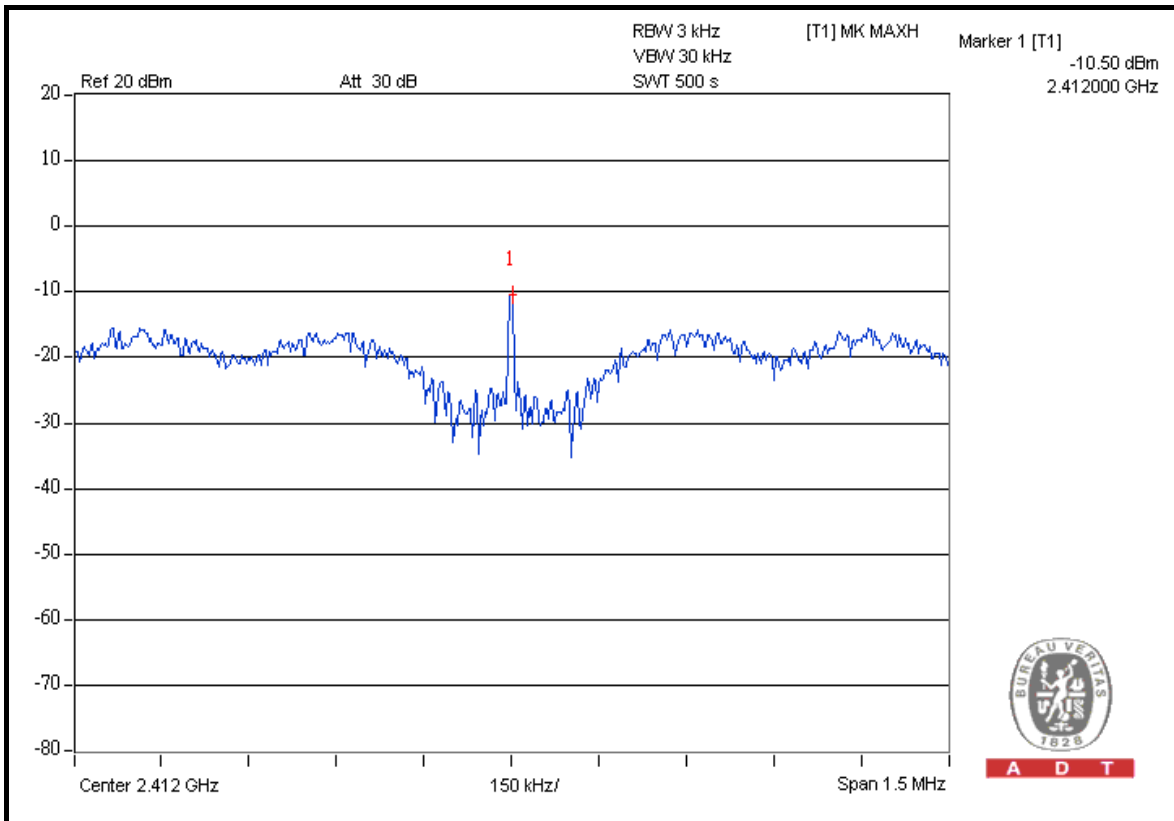



A D T

CH 6

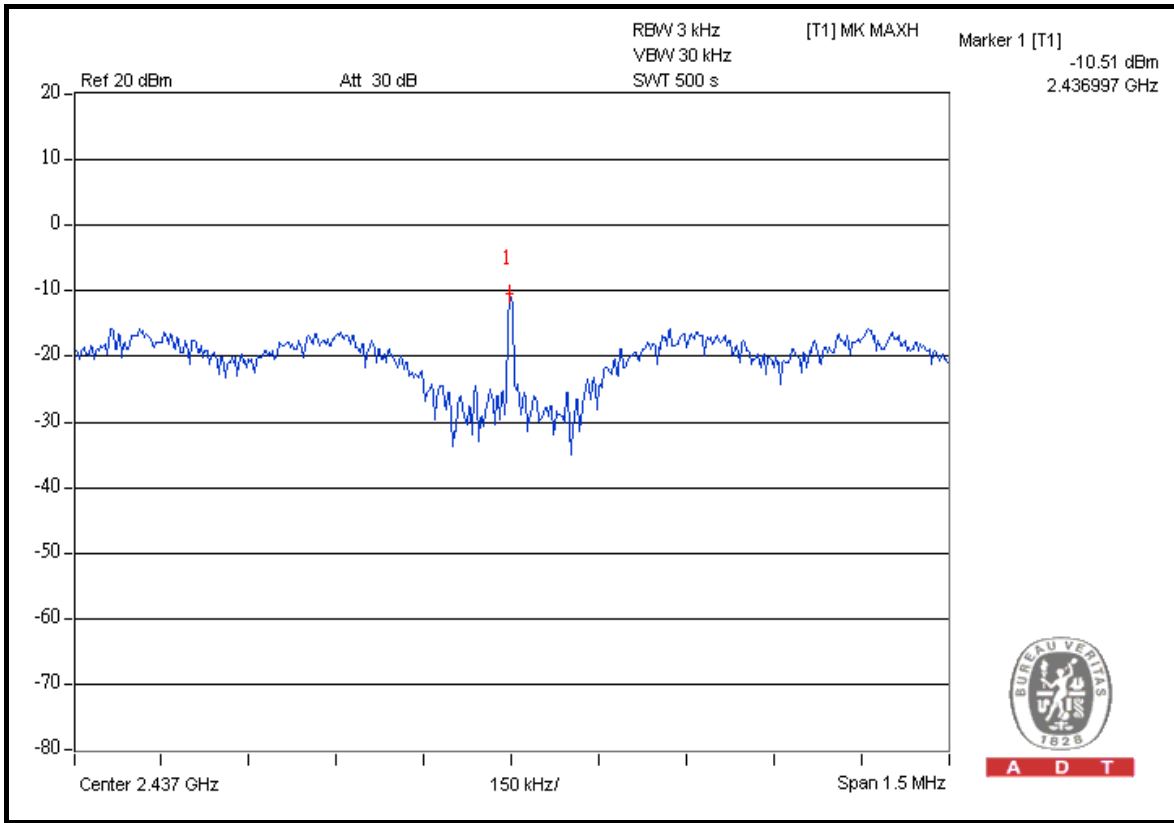

CH 11

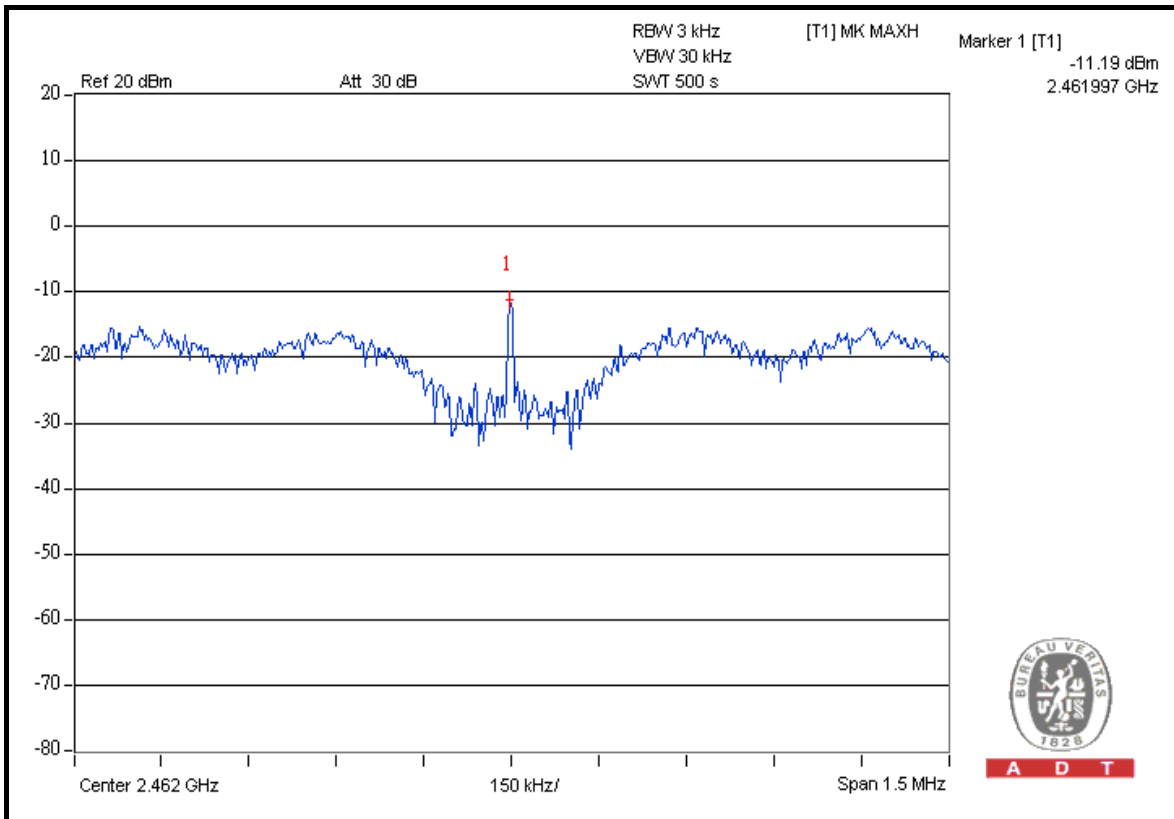



A D T

DRAFT 802.11n (20MHz) OFDM MODULATION

MODULATION TYPE	BPSK	TRANSFER RATE	7.2Mbps
INPUT POWER	120Vac, 60Hz	ENVIRONMENTAL CONDITIONS	24 deg.C, 64 %RH, 1009hPa
TESTED BY	Lori Chiu		

CHAN.	CHAN. FREQ. (MHz)	RF POWER LEVEL IN 3kHz BW (dBm)		TOTAL POWER DENSITY (mW)	TOTAL POWER DENSITY (dBm)	MAX. LIMIT (dBm)	PASS / FAIL
		CHAIN 0	CHAIN 1				
1	2412	-7.56	-11.31	0.249	-6.04	8	PASS
6	2437	-7.32	-10.91	0.266	-5.75	8	PASS
11	2462	-7.57	-11.16	0.252	-5.99	8	PASS



A D T

FOR CHAIN 0 : CH 1

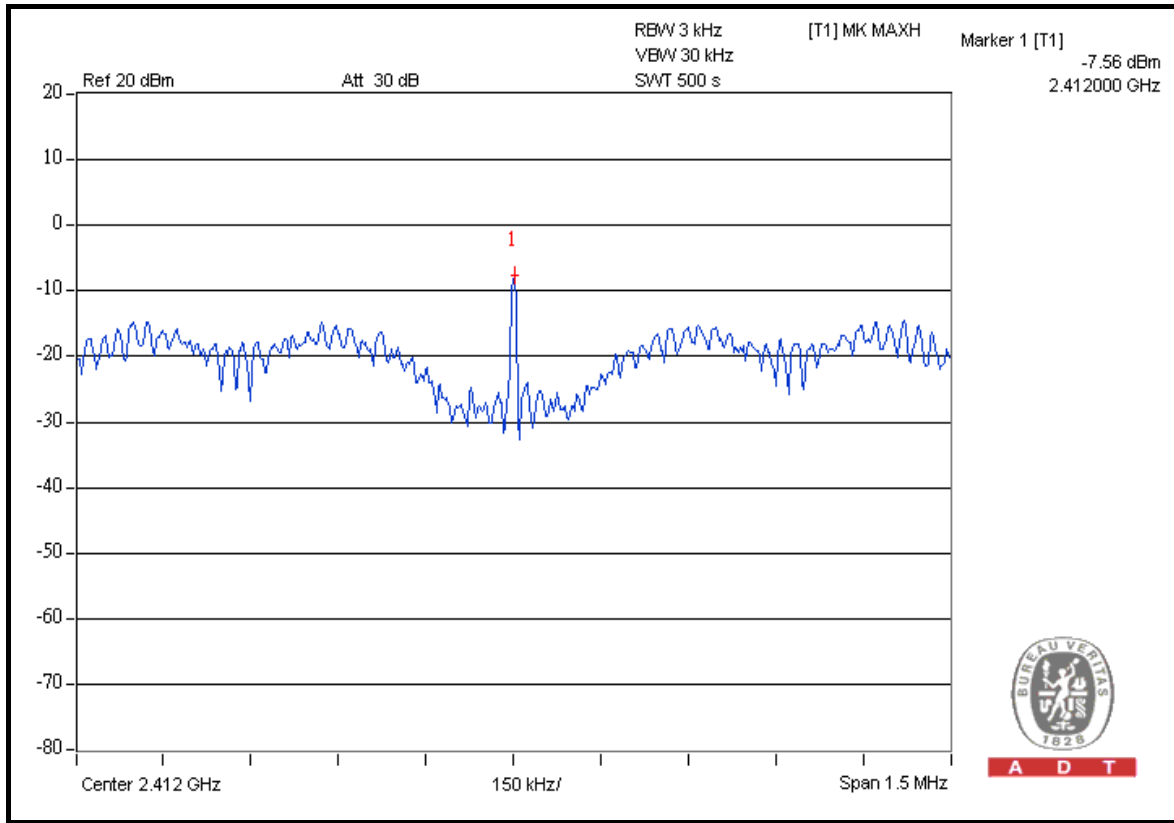

CH 6

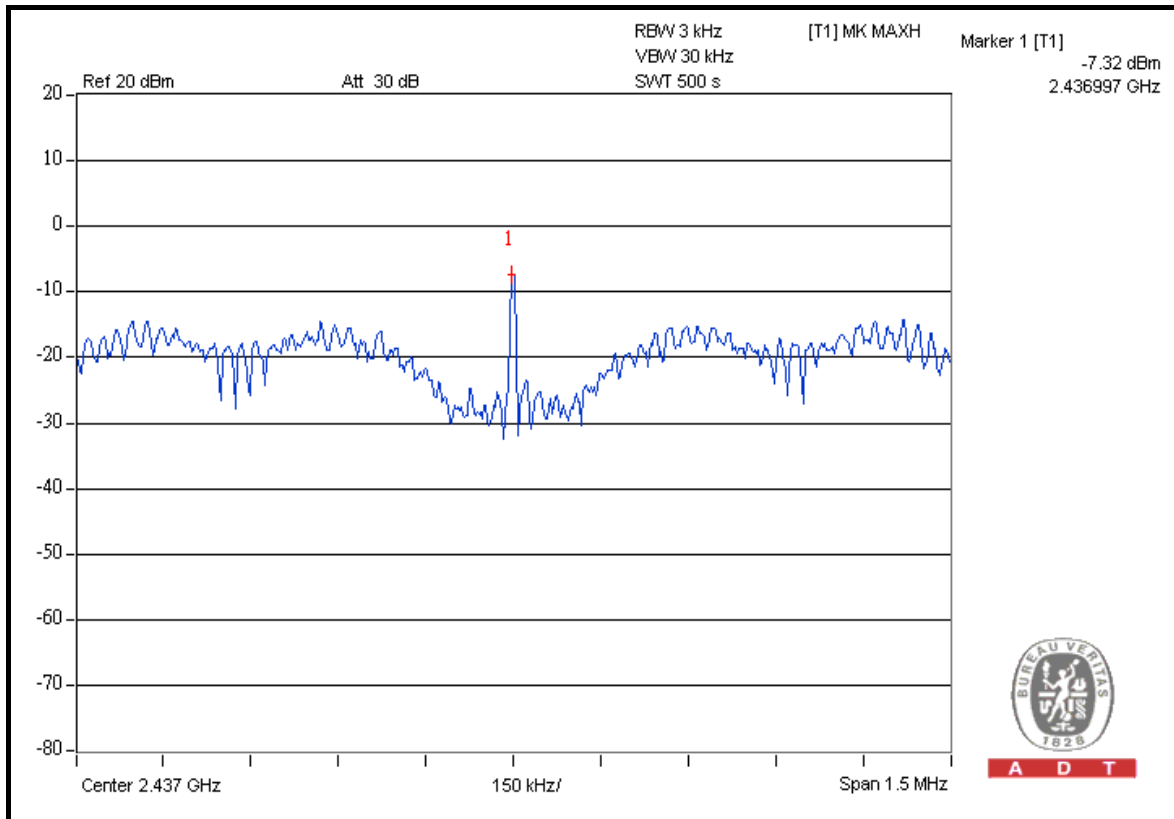



A D T

CH 11

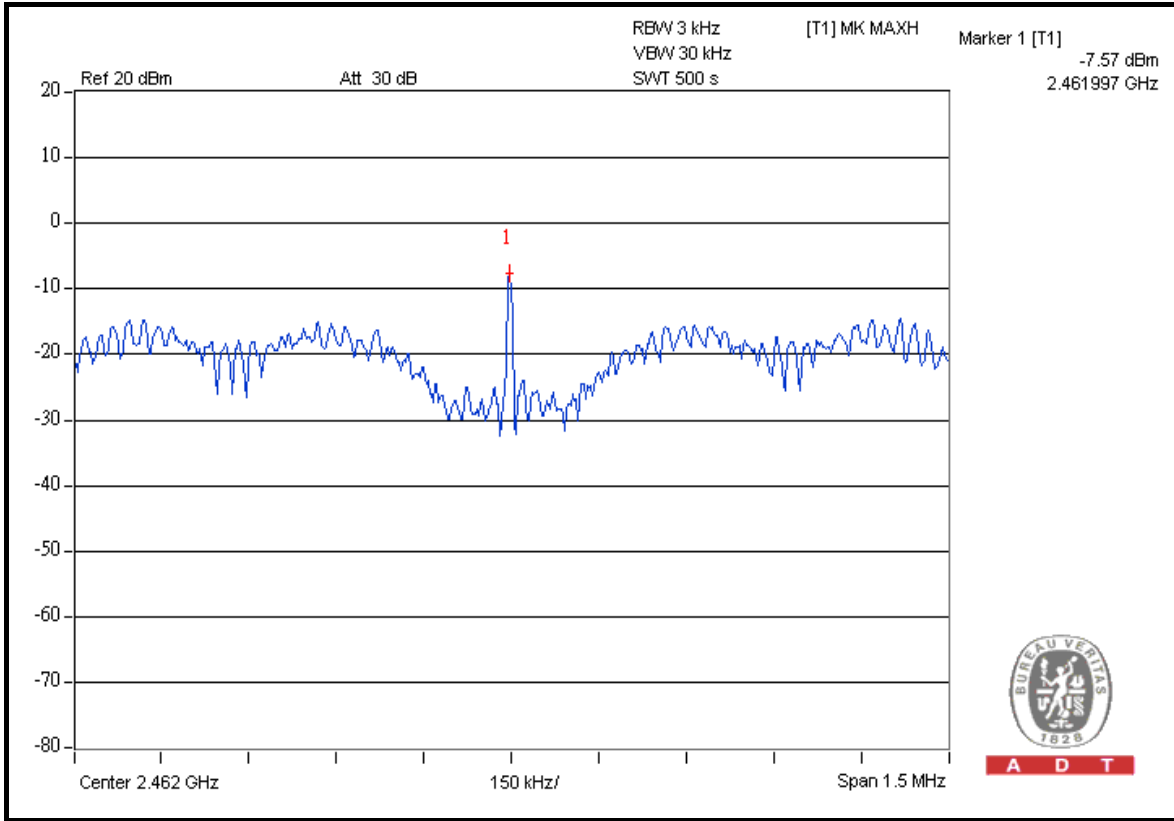

FOR CHAIN 1: CH 1

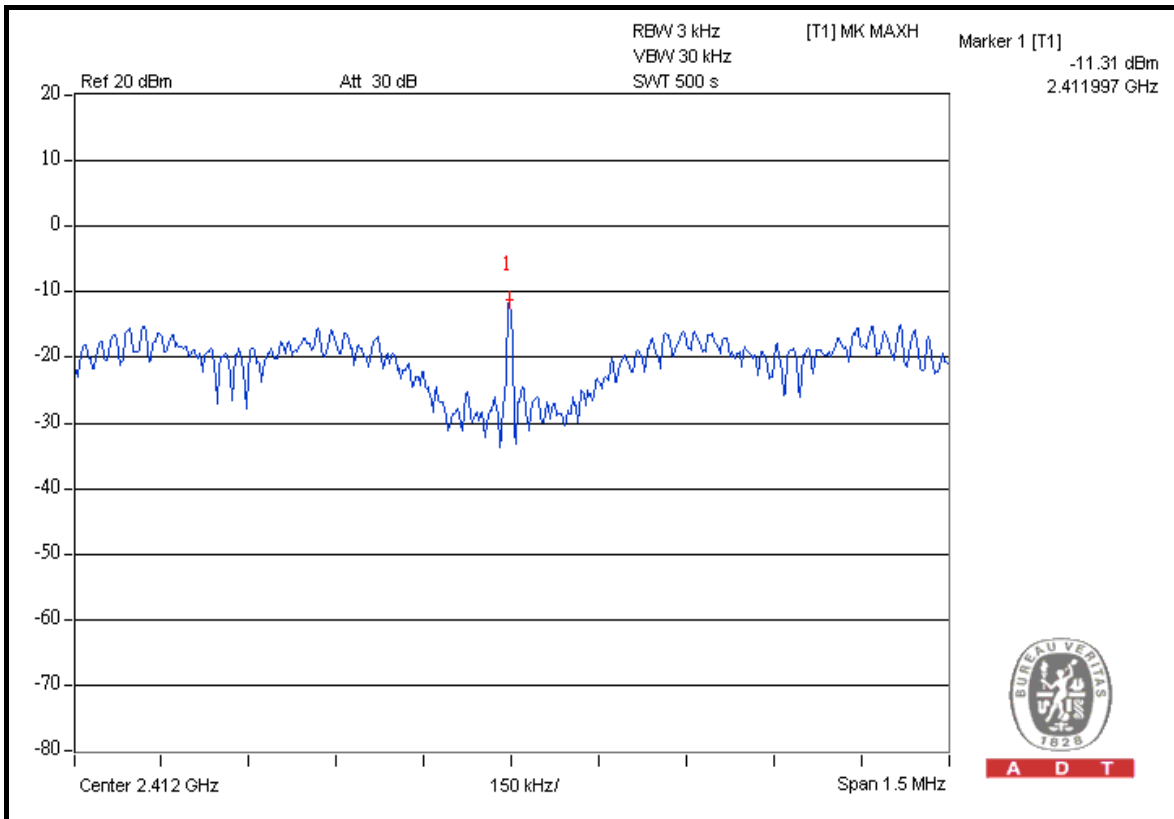



A D T

CH 6

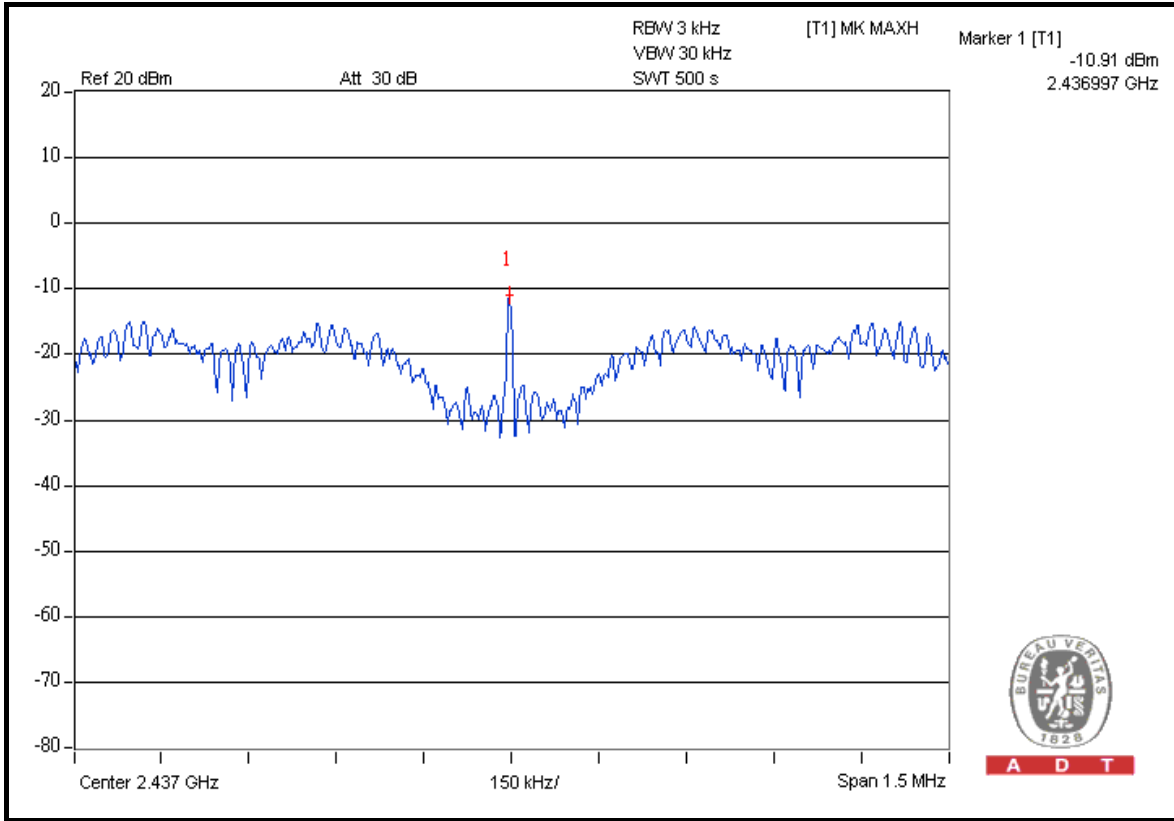

CH 11

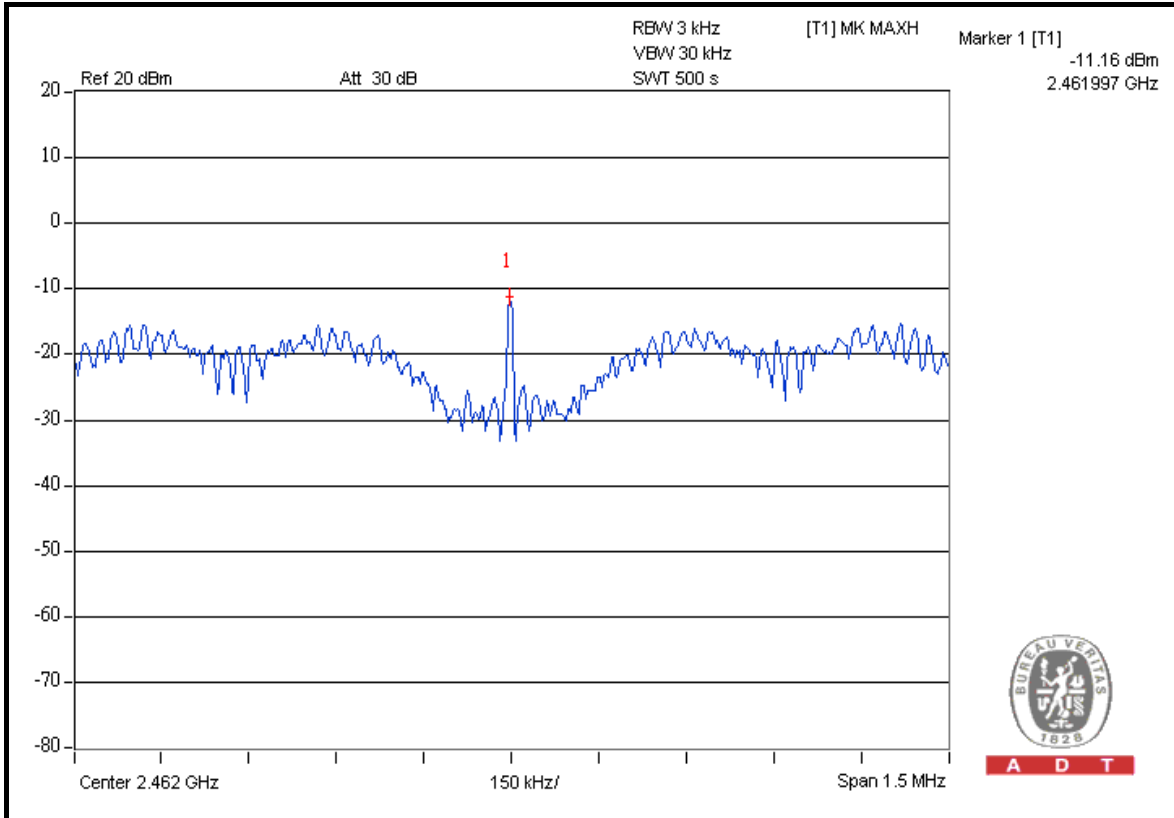



A D T

DRAFT 802.11n (40MHz) OFDM MODULATION

MODULATION TYPE	BPSK	TRANSFER RATE	15.0Mbps
INPUT POWER	120Vac, 60Hz	ENVIRONMENTAL CONDITIONS	24 deg.C, 64 %RH, 1009hPa
TESTED BY	Lori Chiu		

CHAN.	CHAN. FREQ. (MHz)	RF POWER LEVEL IN 3kHz BW (dBm)		TOTAL POWER DENSITY (mW)	TOTAL POWER DENSITY (dBm)	MAX. LIMIT (dBm)	PASS / FAIL
		CHAIN 0	CHAIN 1				
1	2422	-9.33	-13.38	0.163	-7.88	8	PASS
4	2437	-8.51	-12.97	0.191	-7.19	8	PASS
7	2452	-9.38	-13.79	0.157	-8.04	8	PASS



A D T

FOR CHAIN 0: CH 1

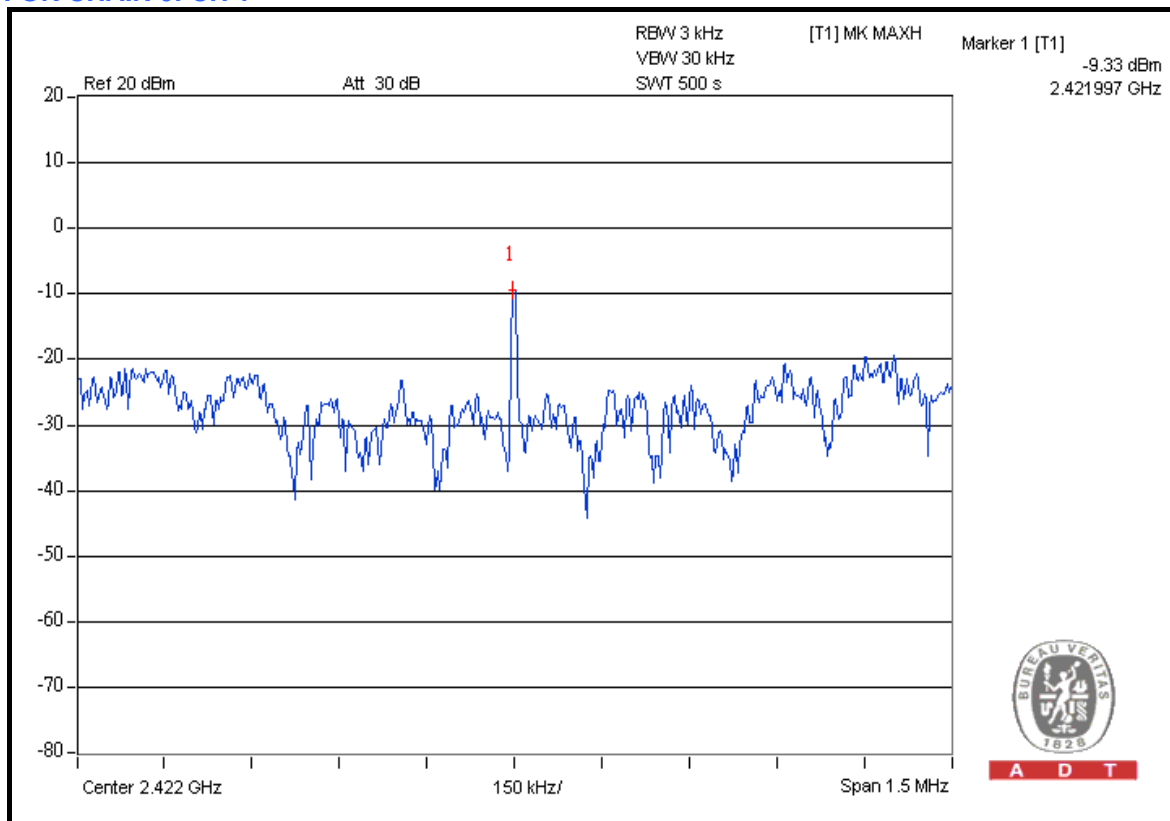

A D T

CH 4

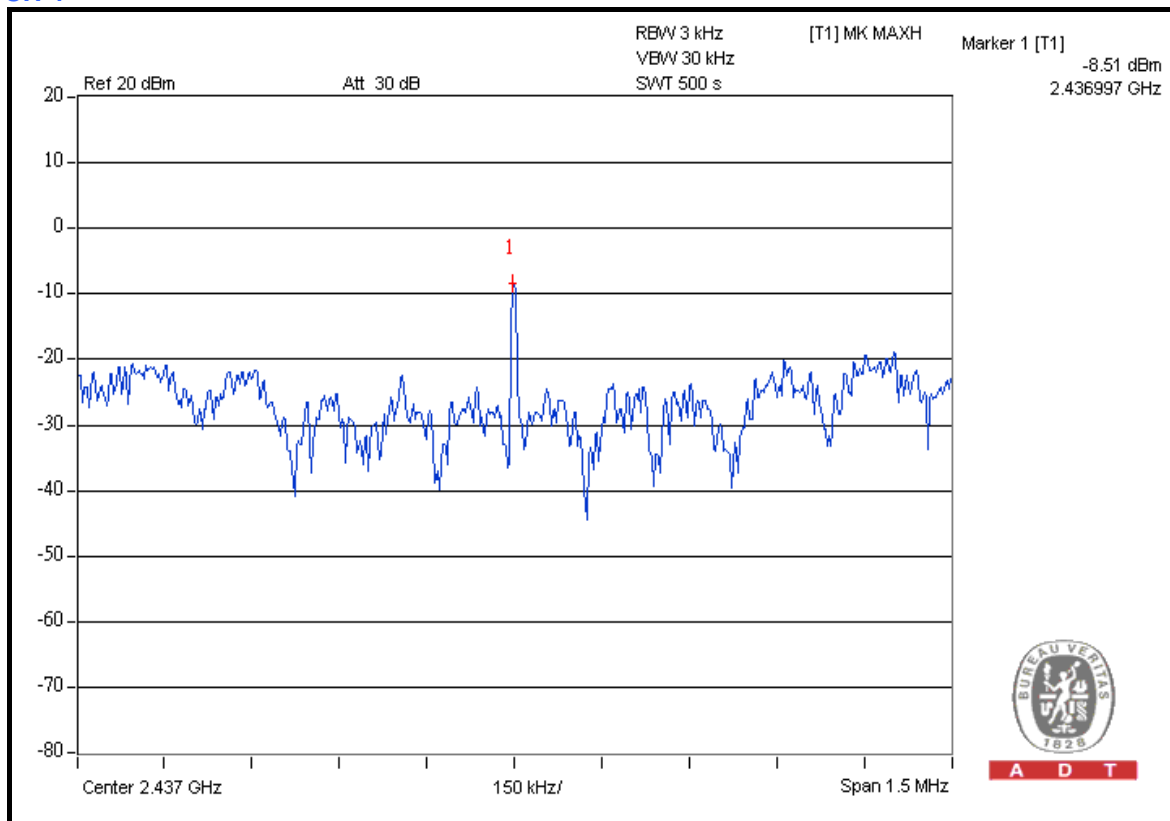

A D T



A D T

CH 7

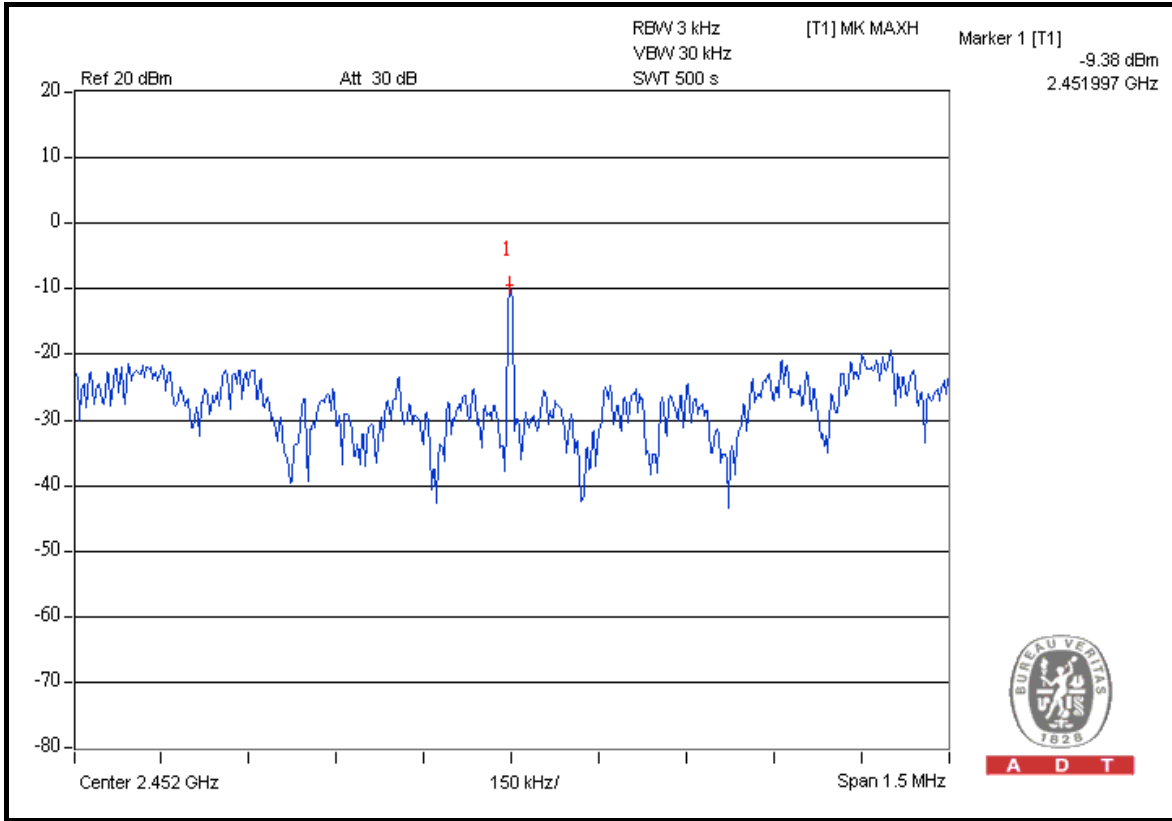

FOR CHAIN 1: CH 1

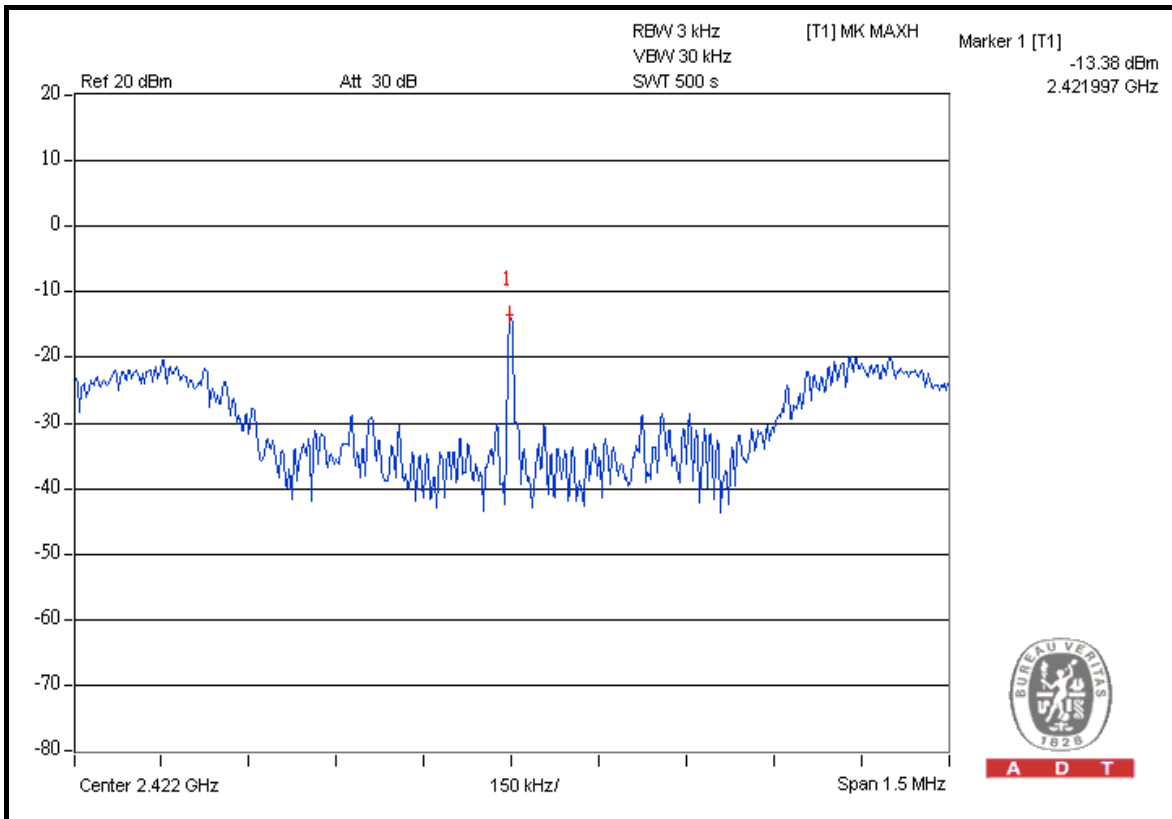



A D T

CH 4

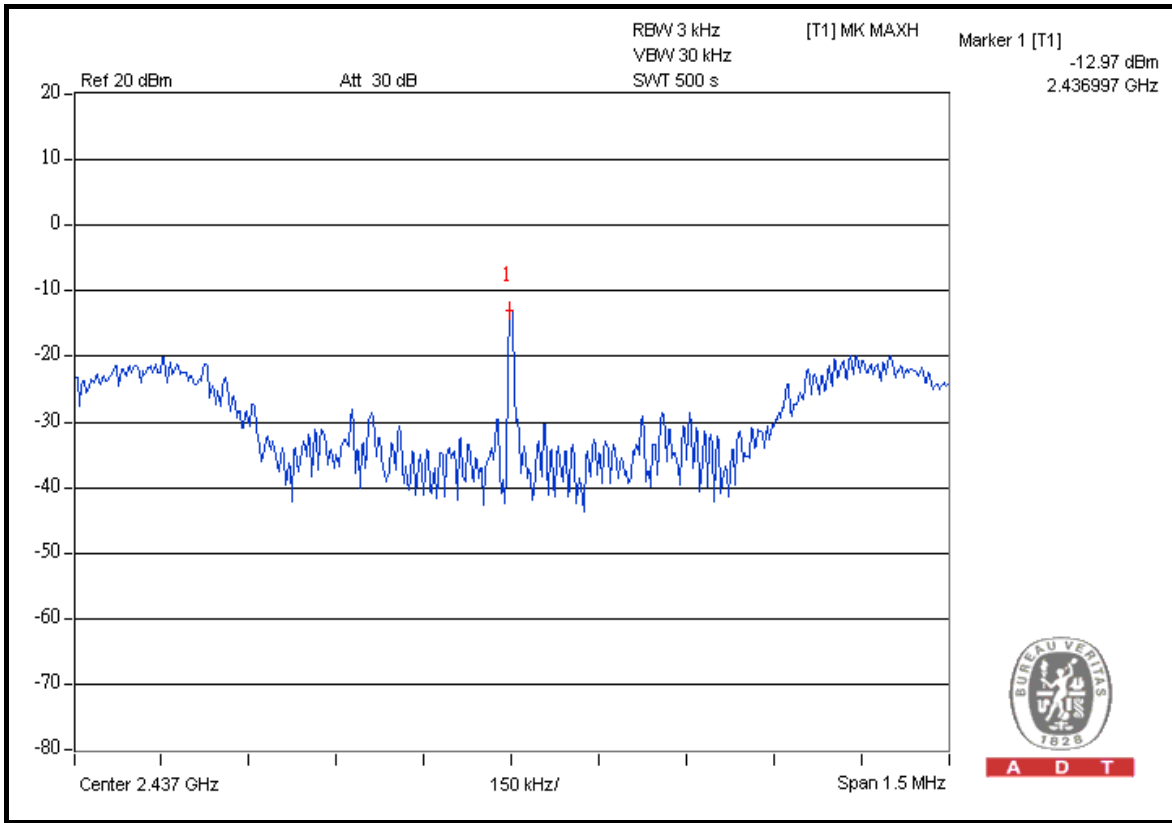

A D T

CH 7

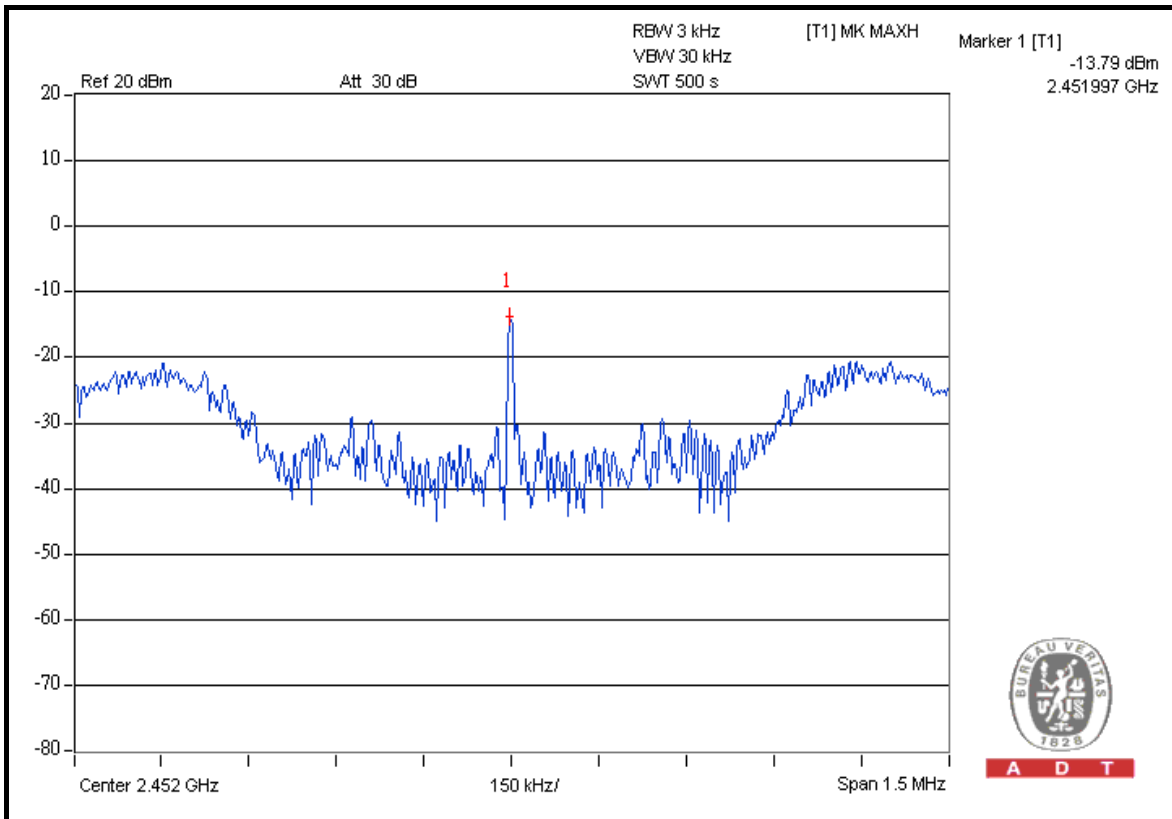

A D T



4.6 BAND EDGES MEASUREMENT

4.6.1 LIMITS OF BAND EDGES MEASUREMENT

Below -20dB of the highest emission level of operating band (in 100kHz Resolution Bandwidth).

4.6.2 TEST INSTRUMENTS

DESCRIPTION & MANUFACTURER	MODEL NO.	SERIAL NO.	DATE OF CALIBRATION	DUE DATE OF CALIBRATION
Test Receiver ROHDE & SCHWARZ	ESIB7	100212	May 25, 2009	May 24, 2010
Spectrum Analyzer ROHDE & SCHWARZ	FSP40	100040	Jul. 07, 2009	Jul. 06, 2010
BILOG Antenna SCHWARZBECK	VULB9168	9168-156	Apr. 30, 2009	Apr. 29, 2010
HORN Antenna SCHWARZBECK	BBHA 9120 D	9120D-563	Aug. 10, 2009	Aug. 09, 2010
HORN Antenna SCHWARZBECK	BBHA 9170	BBHA9170242	Jan. 06, 2009	Jan. 05, 2010
Preamplifier Agilent	8449B	3008A01911	Sep. 10, 2008	Sep. 09, 2009
Preamplifier Agilent	8447D	2944A10638	Dec. 26, 2008	Dec. 25, 2009
RF signal cable HUBER+SUHNNER	SUCOFLEX 104	218190/4 231241/4	May 13, 2009	May 12, 2010
RF signal cable Worken	8D-FB	Cable-HYCH9-01	Aug. 17, 2009	Aug. 16, 2010
Software	ADT_Radiated_ V7.6.15.9.2	NA	NA	NA
Antenna Tower EMCO	2070/2080	512.835.4684	NA	NA
Turn Table EMCO	2087-2.03	NA	NA	NA
Antenna Tower & Turn Table Controller EMCO	2090	NA	NA	NA

NOTE: The calibration interval of the above test instruments is 12 months and the calibrations are traceable to NML/ROC and NIST/USA.



4.6.3 TEST PROCEDURE

- a. The EUT was placed on the top of a rotating table 0.8 meters above the ground at a 3 meter semi-anechoic chamber. The table was rotated 360 degrees to determine the position of the highest radiation.
- b. The EUT was set 3 meters away from the interference-receiving antenna, which was mounted on the top of a variable-height antenna tower.
- c. The antenna is a broadband antenna, and its height is varied from one meter to four meters above the ground to determine the maximum value of the field strength. Both horizontal and vertical polarizations of the antenna are set to make the measurement.
- d. For each suspected emission, the EUT was arranged to its worst case and then the antenna was tuned to heights from 1 meter to 4 meters and the rotatable table was turned from 0 degrees to 360 degrees to find the maximum reading.
- e. Set both RBW and VBW of spectrum analyzer to 100kHz and 300kHz with suitable frequency span including 100MHz bandwidth from band edge. The band edges was measured and recorded.

The spectrum plots (Peak RBW = 100kHz, VBW = 300kHz) are attached on the following pages.

NOTE: The resolution bandwidth of test receiver/spectrum analyzer is 1MHz and the video bandwidth is 10Hz for Average detection (AV) at frequency above 1GHz.

4.6.4 DEVIATION FROM TEST STANDARD

No deviation.

4.6.5 EUT OPERATING CONDITION

Same as Item 4.3.6.

4.6.6 TEST RESULTS

The spectrum plots are attached on the following pages. D1 line indicates the highest level, and D2 line indicates the 20dB offset below D1. It shows compliance with the requirement in part 15.247(d).

802.11b DSSS MODULATION

NOTE 1: The band edge emission plot on the next page shows 51.41dBc between carrier maximum power and local maximum emission in restrict band (2.36000GHz). The emission of carrier strength list in the test result of channel 1 at the item 4.1.7 is 109.04dBuV/m (Peak), so the maximum field strength in restrict band is $109.04 - 51.41 = 57.63$ dBuV/m which is under 74dBuV/m limit.

The band edge emission plot of on the next page shows 58.59dBc between carrier maximum power and local maximum emission in restrict band (2.38680GHz). The emission of carrier strength list in the test result of channel 1 at the item 4.1.7 is 105.08dBuV/m (Average), so the maximum field strength in restrict band is $105.08 - 58.59 = 46.49$ dBuV/m which is under 54dBuV/m limit.

NOTE 2: The band edge emission plot on the next second page shows 51.02dBc between carrier maximum power and local maximum emission in restrict band (2.49200GHz). The emission of carrier strength list in the test result of channel 11 at the item 4.1.7 is 110.75dBuV/m (Peak), so the maximum field strength in restrict band is $108.87 - 51.02 = 57.85$ dBuV/m which is under 74dBuV/m limit.

The band edge emission plot on the next third page shows 57.69dBc between carrier maximum power and local maximum emission in restrict band (2.48360GHz). The emission of carrier strength list in the test result of channel 11 at the item 4.1.7 is 104.84dBuV/m (Average), so the maximum field strength in restrict band is $104.84 - 57.69 = 47.15$ dBuV/m which is under 54dBuV/m limit.



A D T

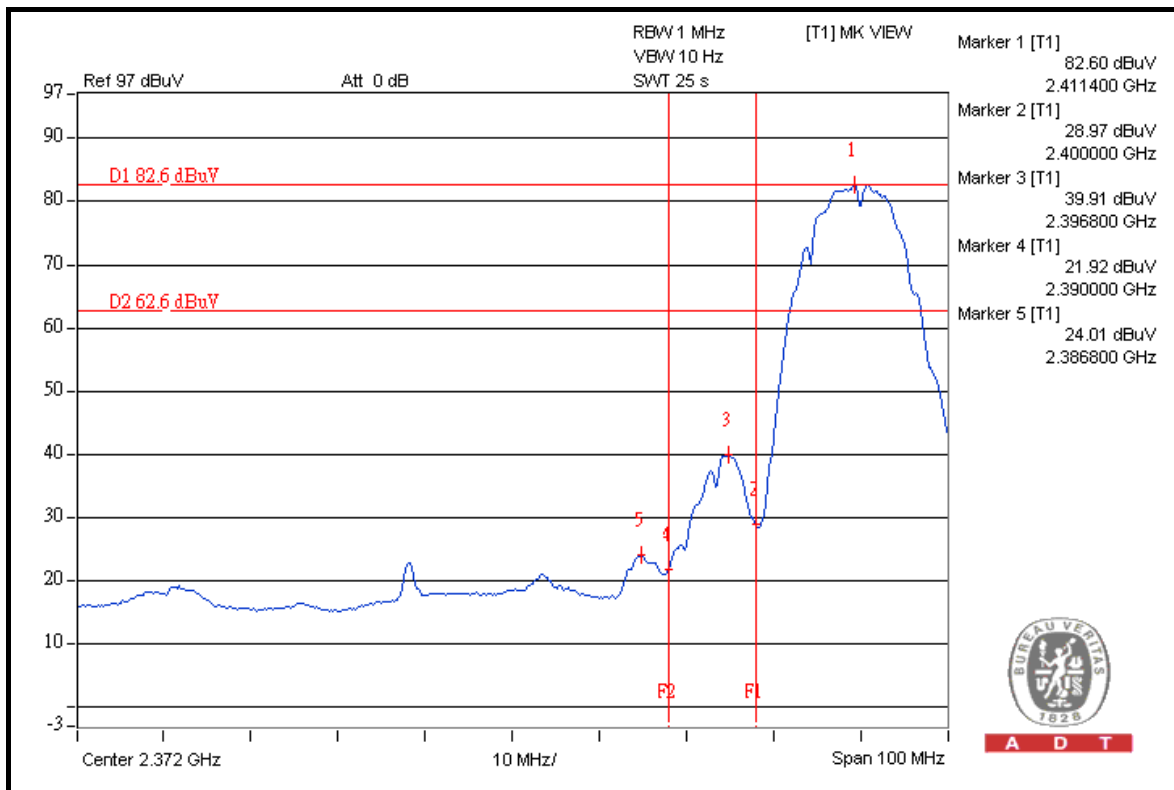
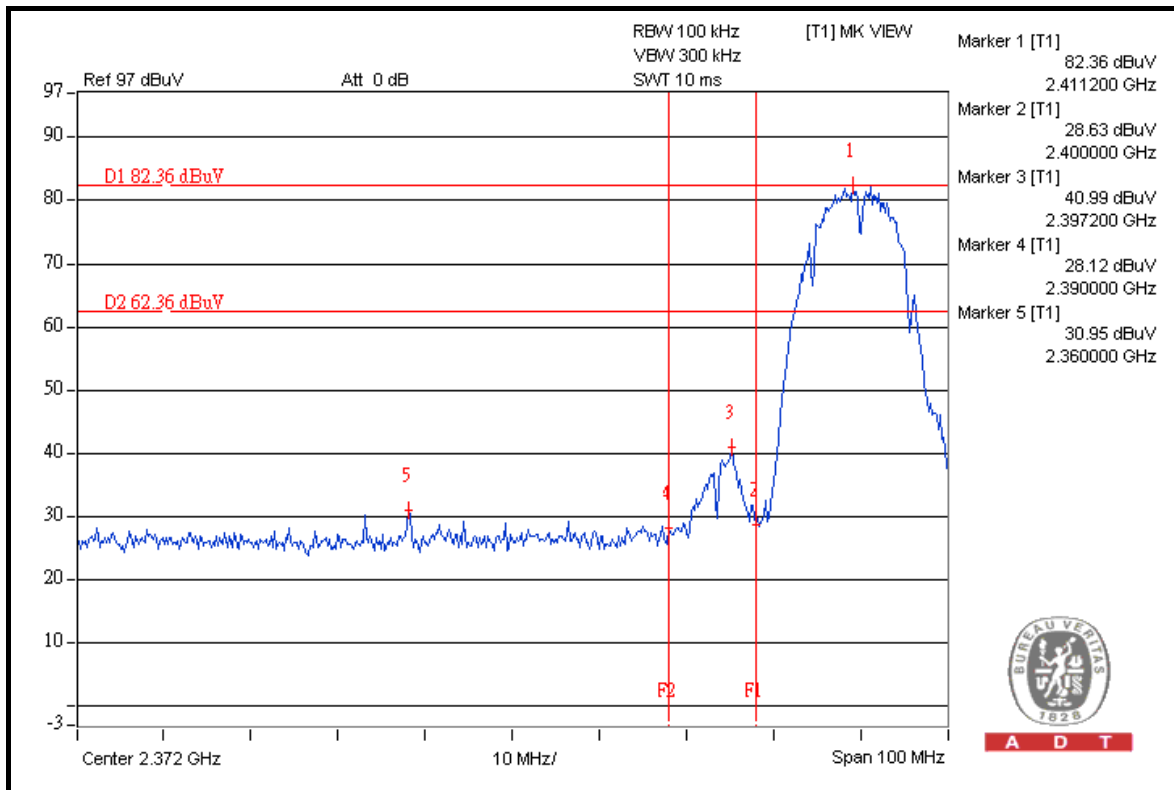



A D T

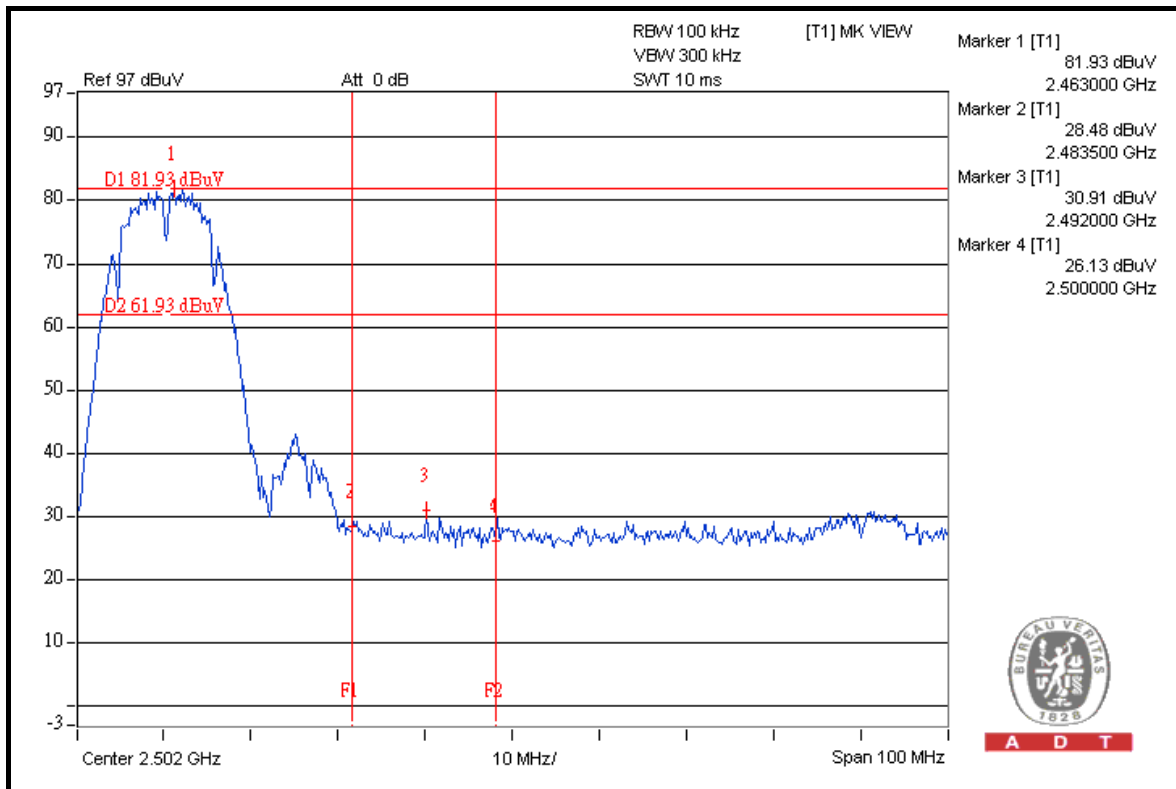
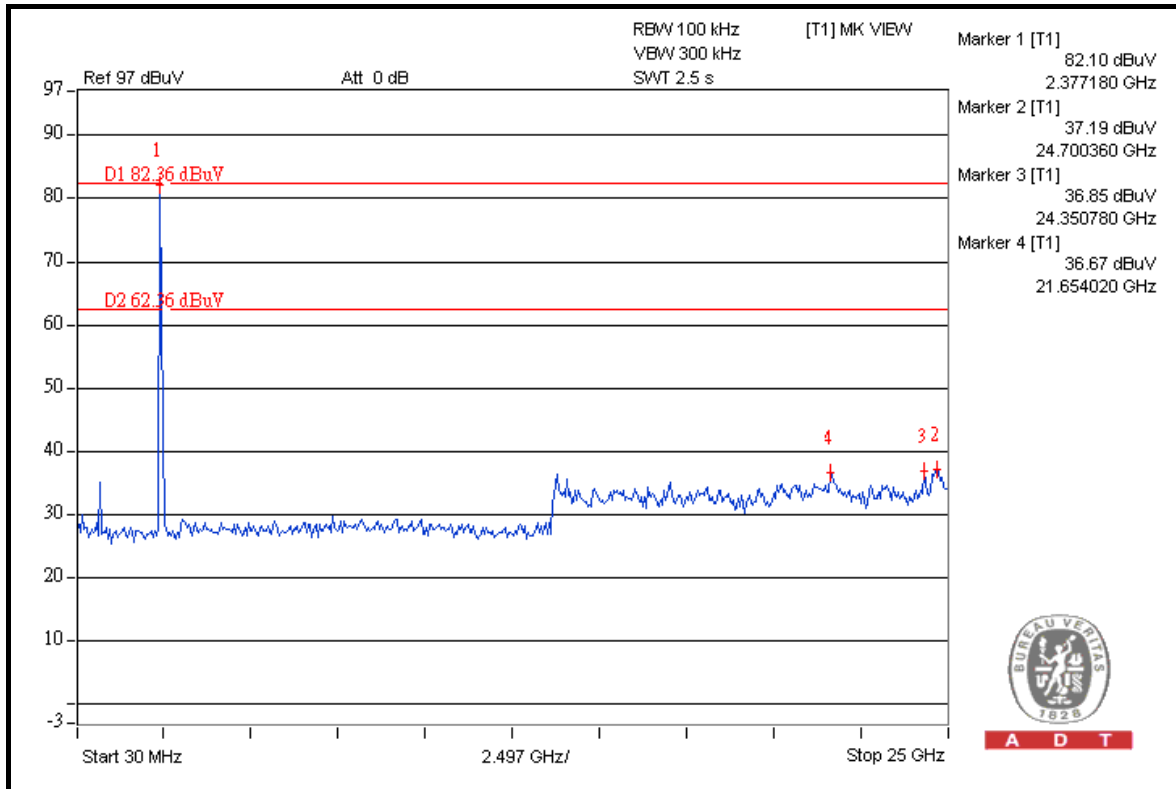



A D T

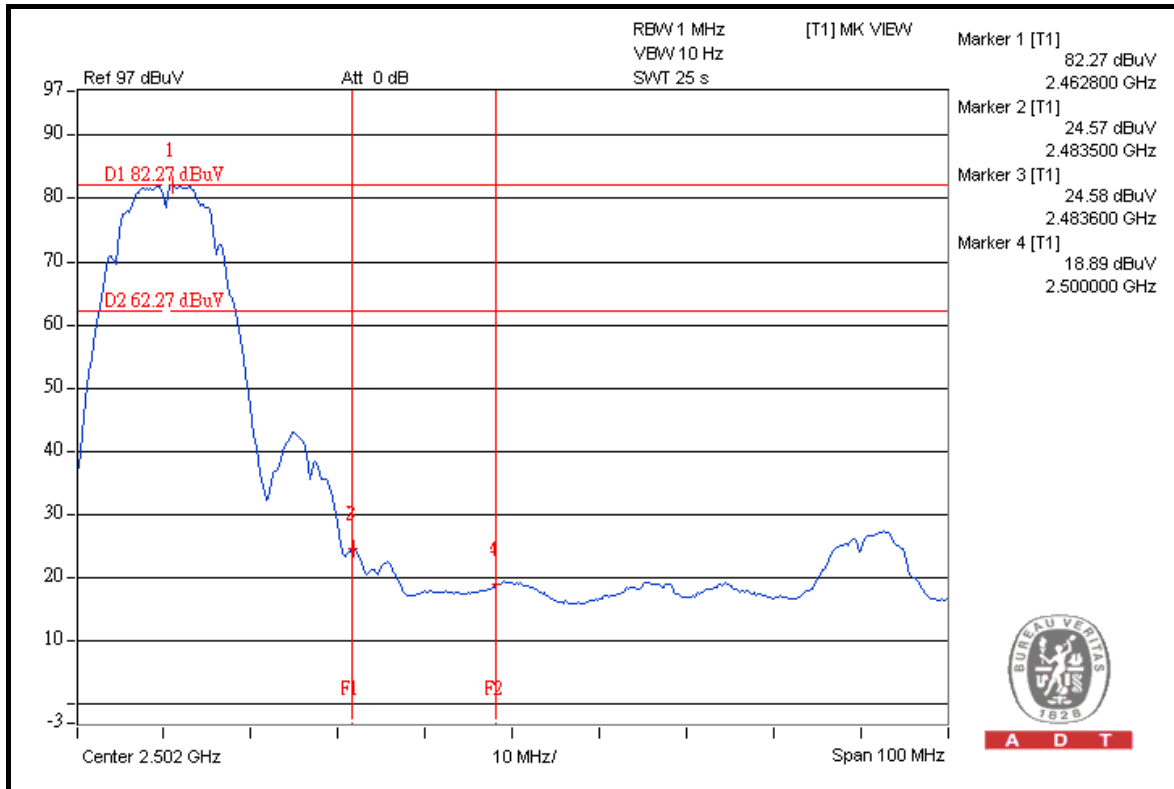

A D T

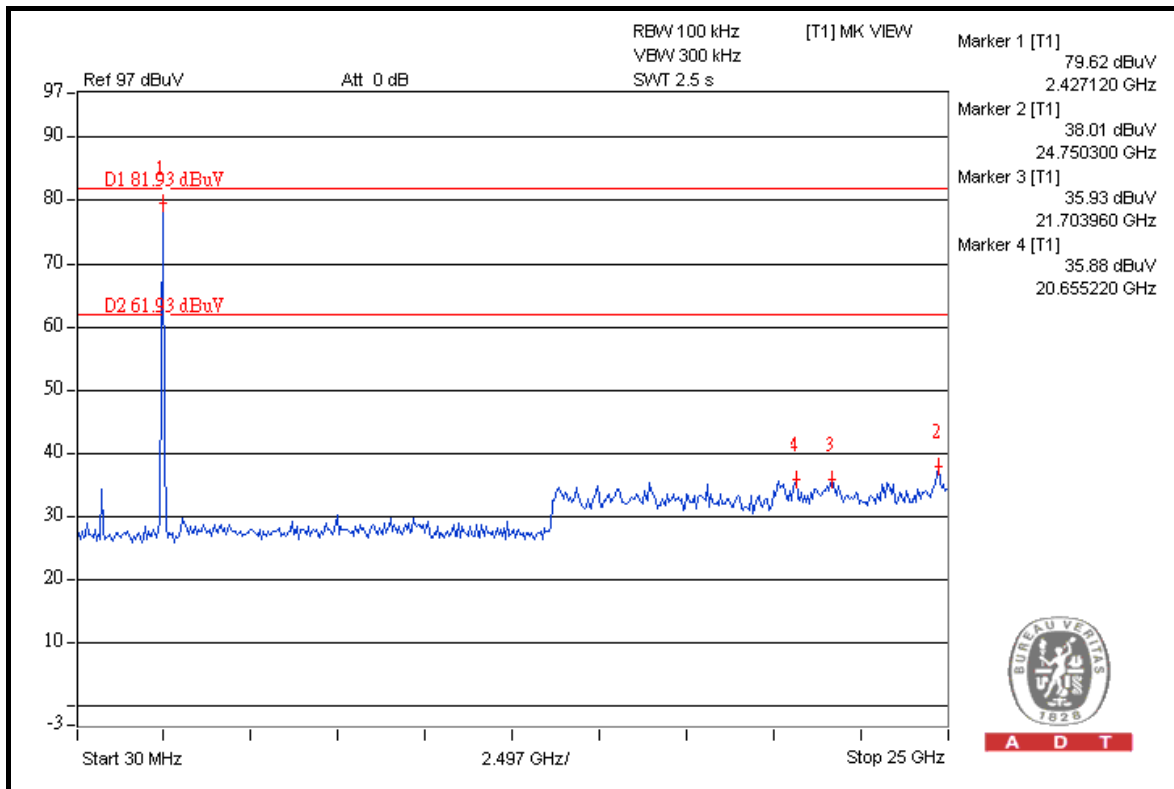

A D T



802.11g OFDM MODULATION

NOTE 1: The band edge emission plot on the next page shows 46.03dBc between carrier maximum power and local maximum emission in restrict band (2.36440GHz). The emission of carrier strength list in the test result of channel 1 at the item 4.1.7 is 108.78dBuV/m (Peak), so the maximum field strength in restrict band is $108.78 - 46.03 = 62.75$ dBuV/m which is under 74dBuV/m limit.

The band edge emission plot of on the next page shows 53.99dBc between carrier maximum power and local maximum emission in restrict band (2.35980GHz). The emission of carrier strength list in the test result of channel 1 at the item 4.1.7 is 98.41dBuV/m (Average), so the maximum field strength in restrict band is $98.41 - 53.99 = 44.42$ dBuV/m which is under 54dBuV/m limit.

NOTE 2: The band edge emission plot on the next second page shows 44.24dBc between carrier maximum power and local maximum emission in restrict band (2.48460GHz). The emission of carrier strength list in the test result of channel 11 at the item 4.1.7 is 108.51dBuV/m (Peak), so the maximum field strength in restrict band is $108.51 - 44.24 = 64.27$ dBuV/m which is under 74dBuV/m limit.

The band edge emission plot on the next third page shows 52.15dBc between carrier maximum power and local maximum emission in restrict band (2.48350GHz). The emission of carrier strength list in the test result of channel 11 at the item 4.1.7 is 98.18dBuV/m (Average), so the maximum field strength in restrict band is $98.18 - 52.15 = 46.03$ dBuV/m which is under 54dBuV/m limit.



A D T

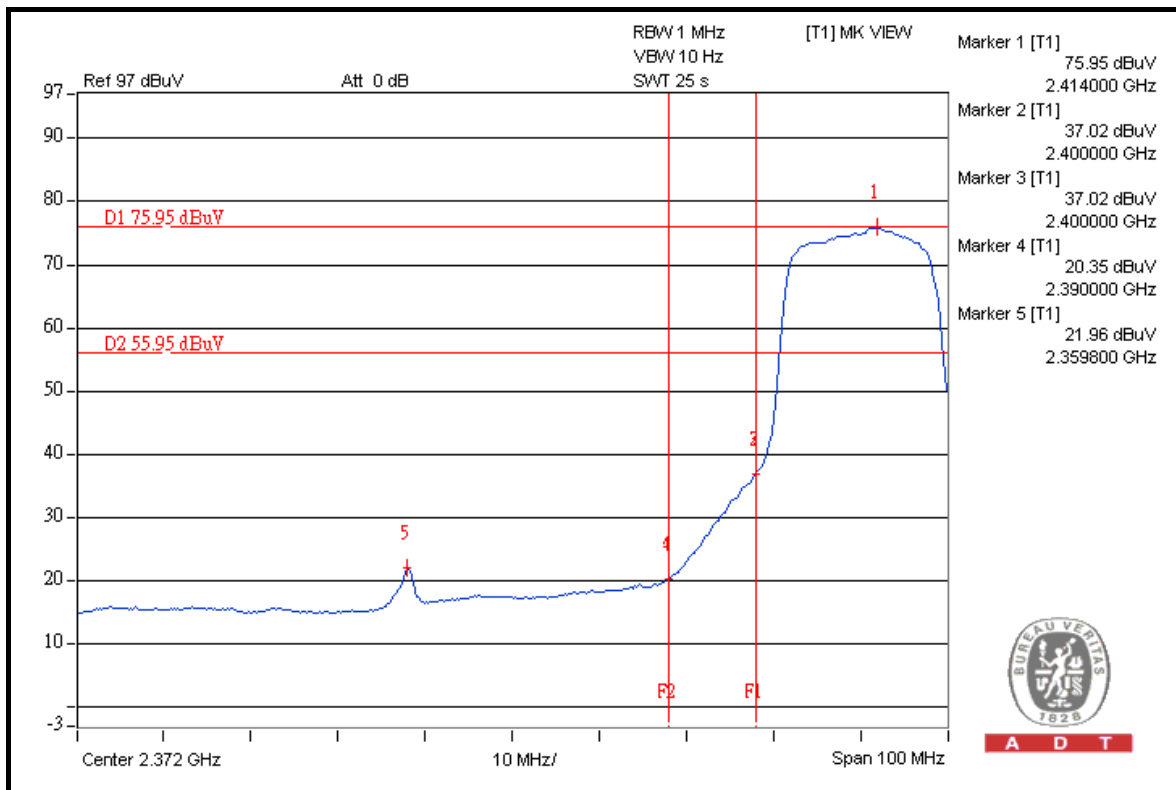
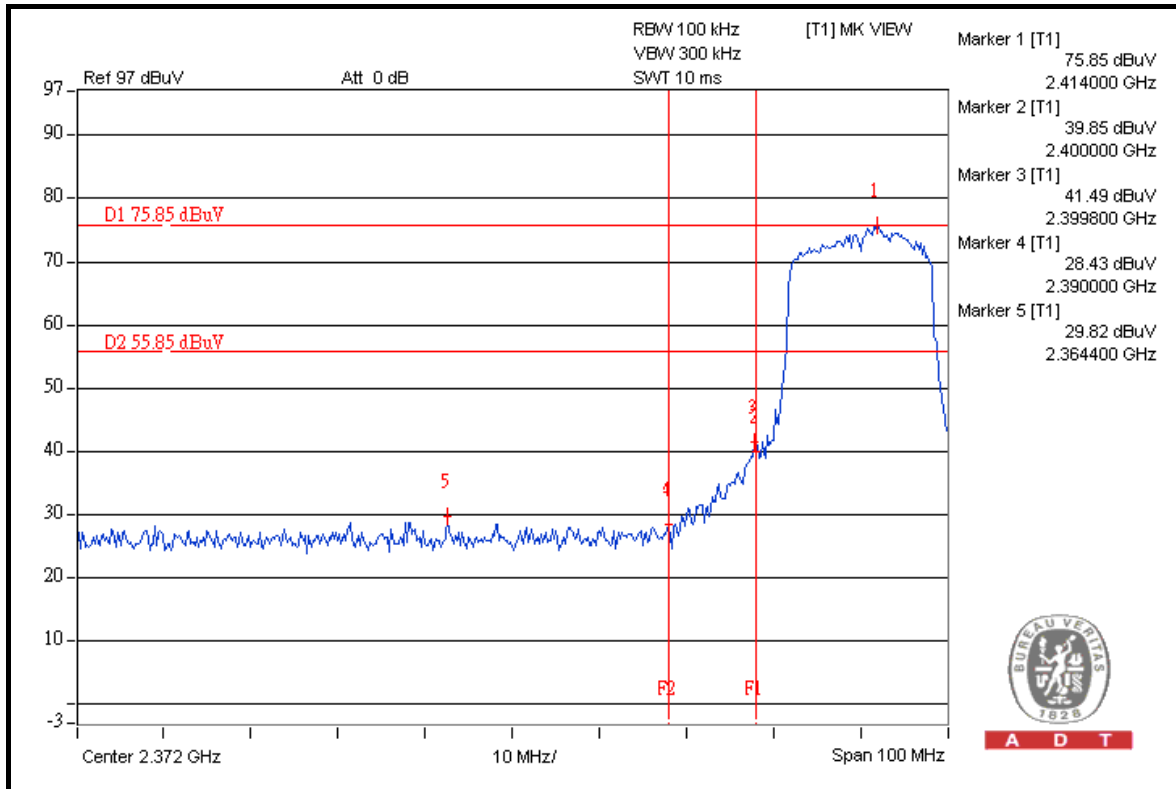



A D T

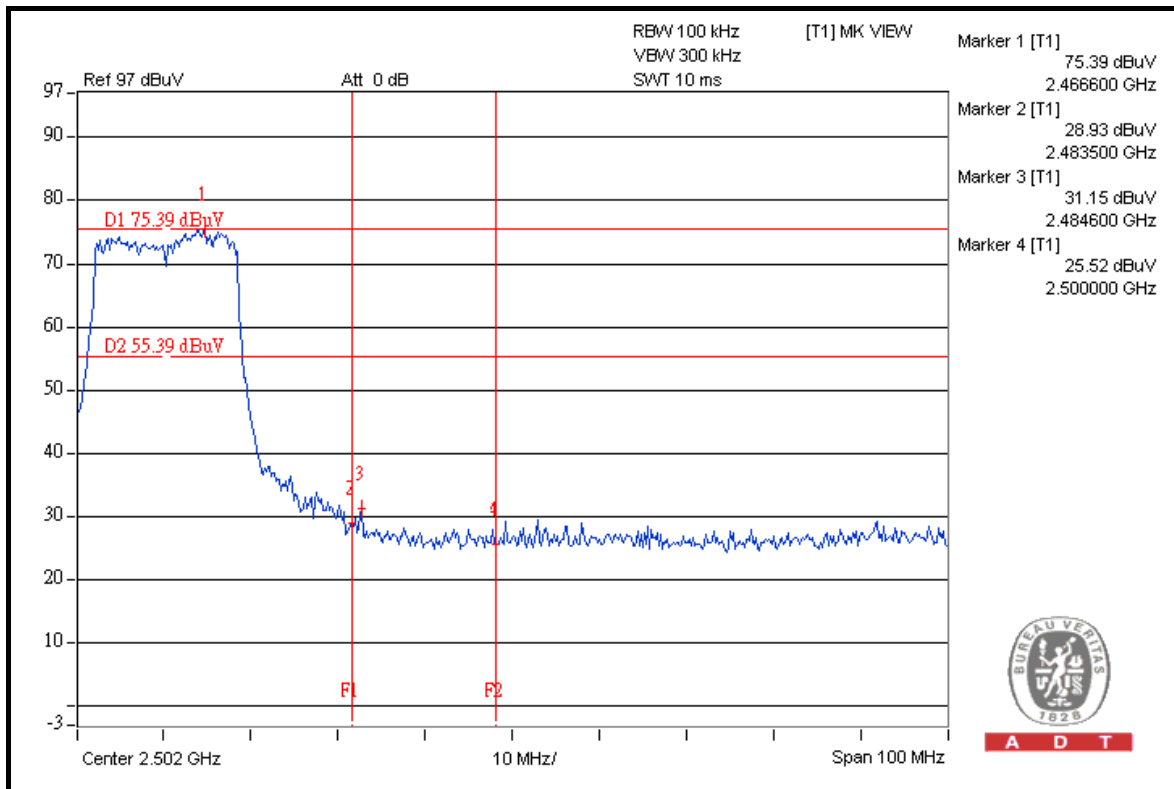
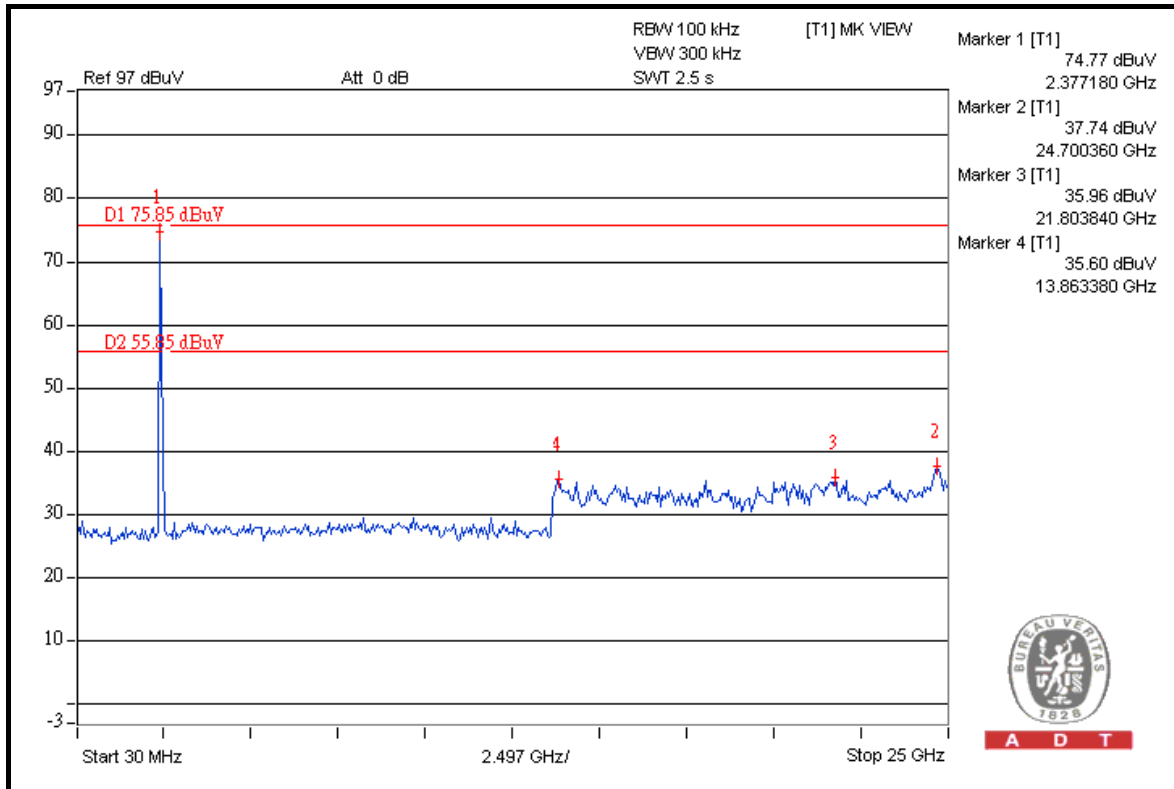



A D T

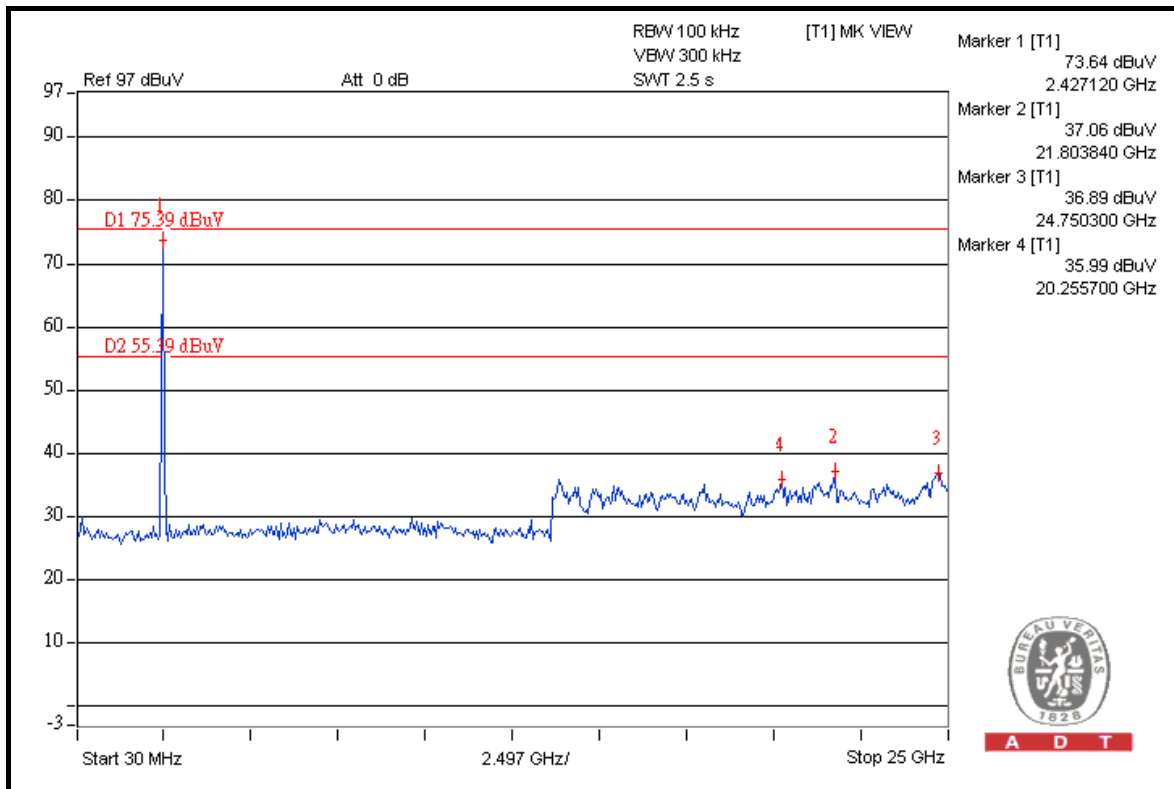
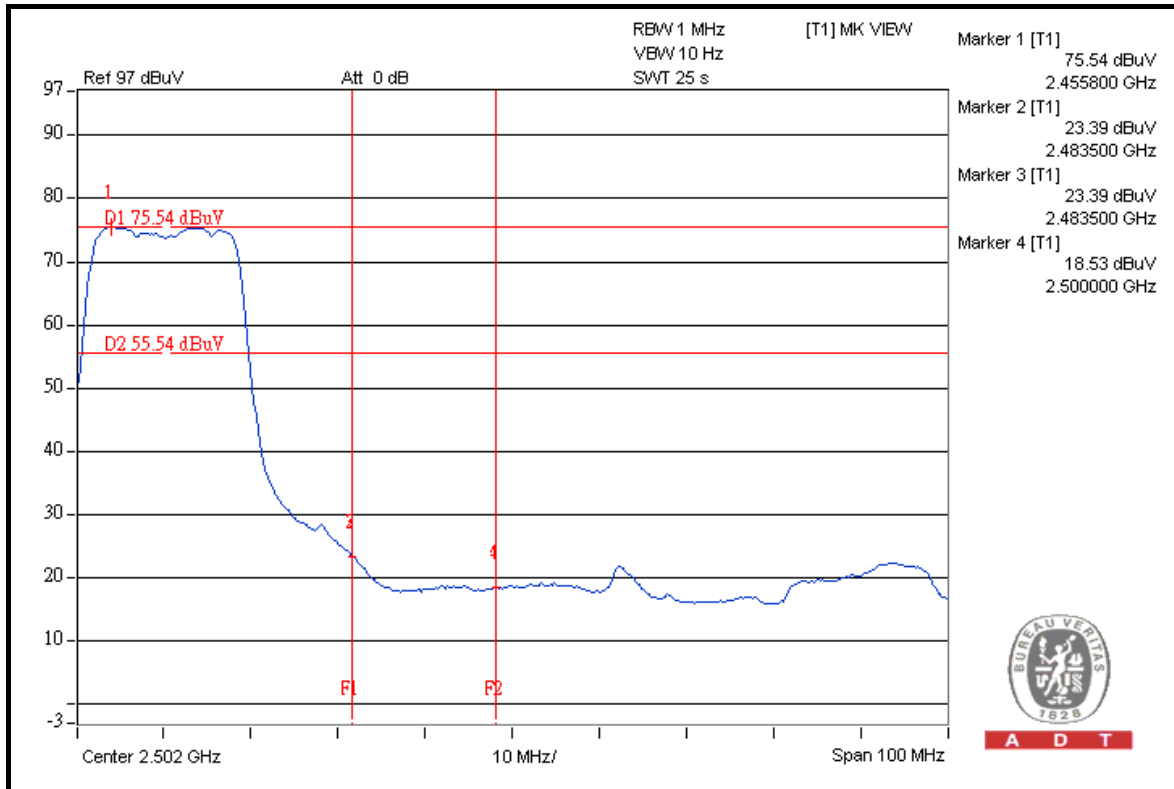



DRAFT 802.11n (20MHz) OFDM MODULATION

NOTE 1: The band edge emission plot on the next page shows 47.28dBc between carrier maximum power and local maximum emission in restrict band (2.36000GHz). The emission of carrier strength list in the test result of channel 1 at the item 4.1.7 is 109.64dBuV/m (Peak), so the maximum field strength in restrict band is $109.64 - 47.28 = 62.36$ dBuV/m which is under 74dBuV/m limit.

The band edge emission plot of on the next page shows 52.41dBc between carrier maximum power and local maximum emission in restrict band (2.36000GHz). The emission of carrier strength list in the test result of channel 1 at the item 4.1.7 is 99.55dBuV/m (Average), so the maximum field strength in restrict band is $99.55 - 52.41 = 47.14$ dBuV/m which is under 54dBuV/m limit.

NOTE 2: The band edge emission plot on the next second page shows 44.08dBc between carrier maximum power and local maximum emission in restrict band (2.48440GHz). The emission of carrier strength list in the test result of channel 11 at the item 4.1.7 is 109.59dBuV/m (Peak), so the maximum field strength in restrict band is $109.59 - 44.08 = 65.51$ dBuV/m which is under 74dBuV/m limit.

The band edge emission plot on the next third page shows 49.09dBc between carrier maximum power and local maximum emission in restrict band (2.48350GHz). The emission of carrier strength list in the test result of channel 11 at the item 4.1.7 is 99.51dBuV/m (Average), so the maximum field strength in restrict band is $99.51 - 49.09 = 50.42$ dBuV/m which is under 54dBuV/m limit.



A D T

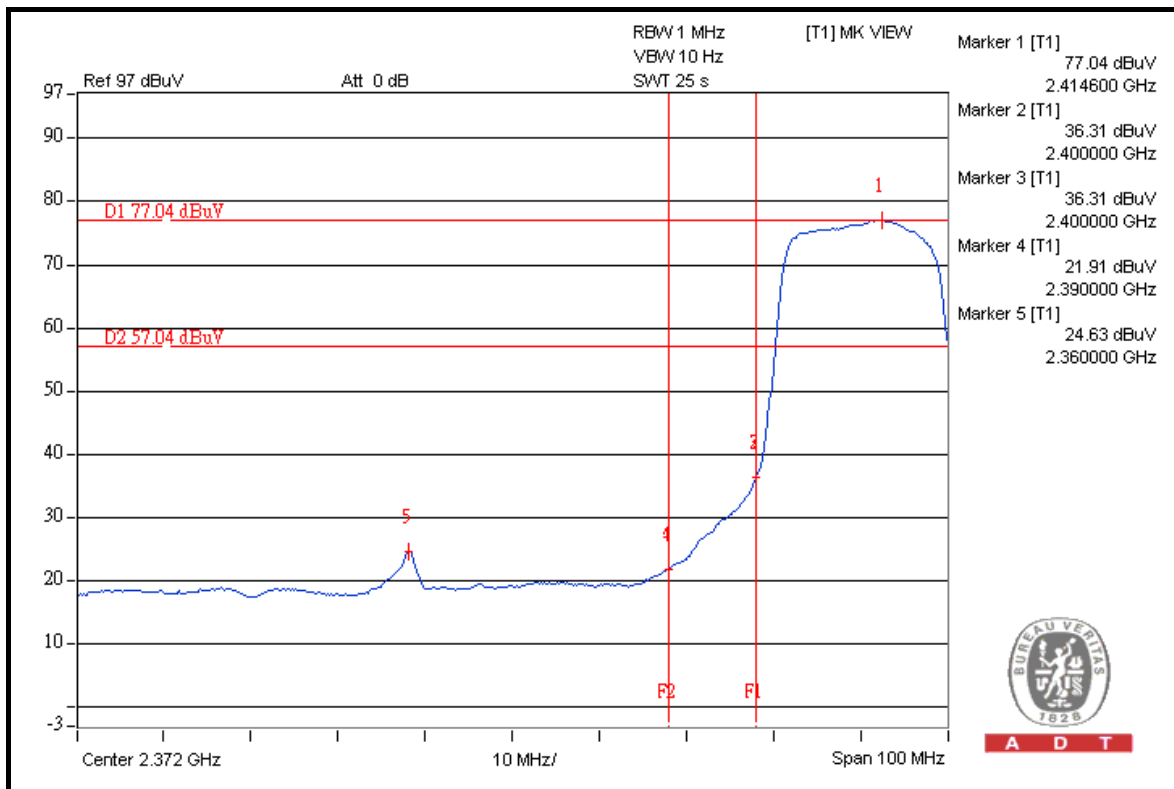
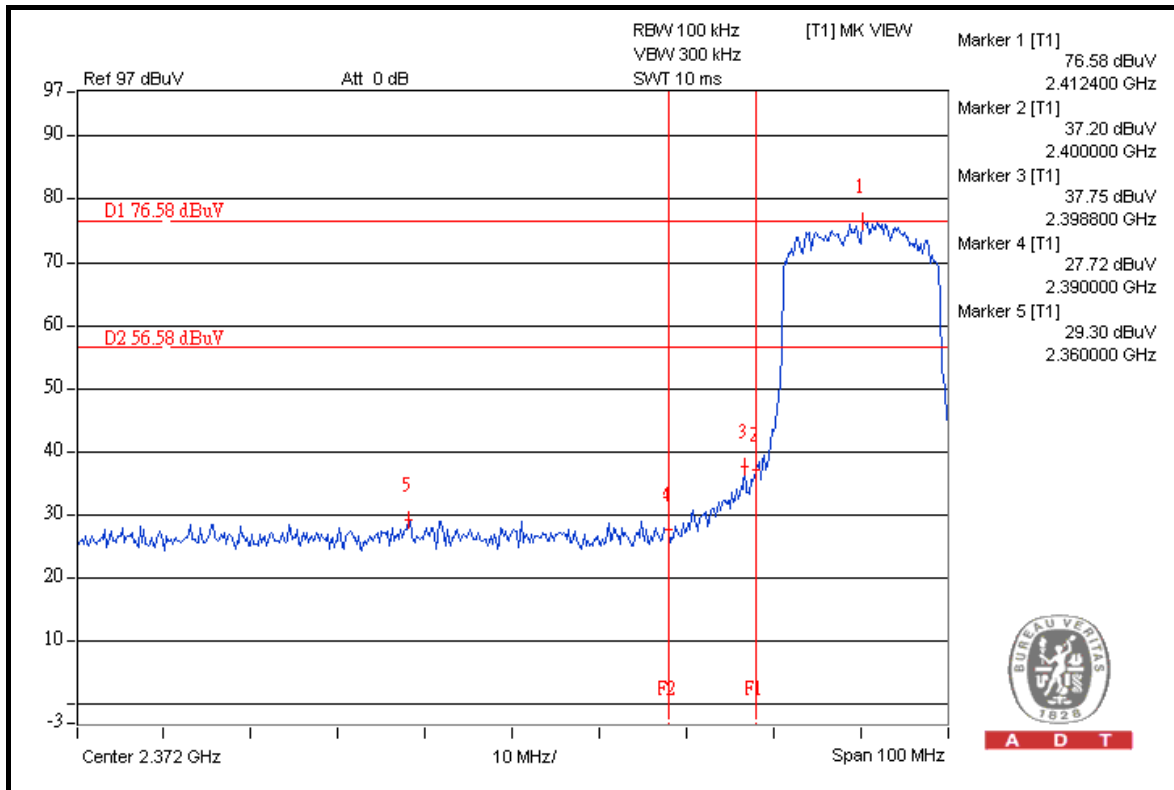



A D T

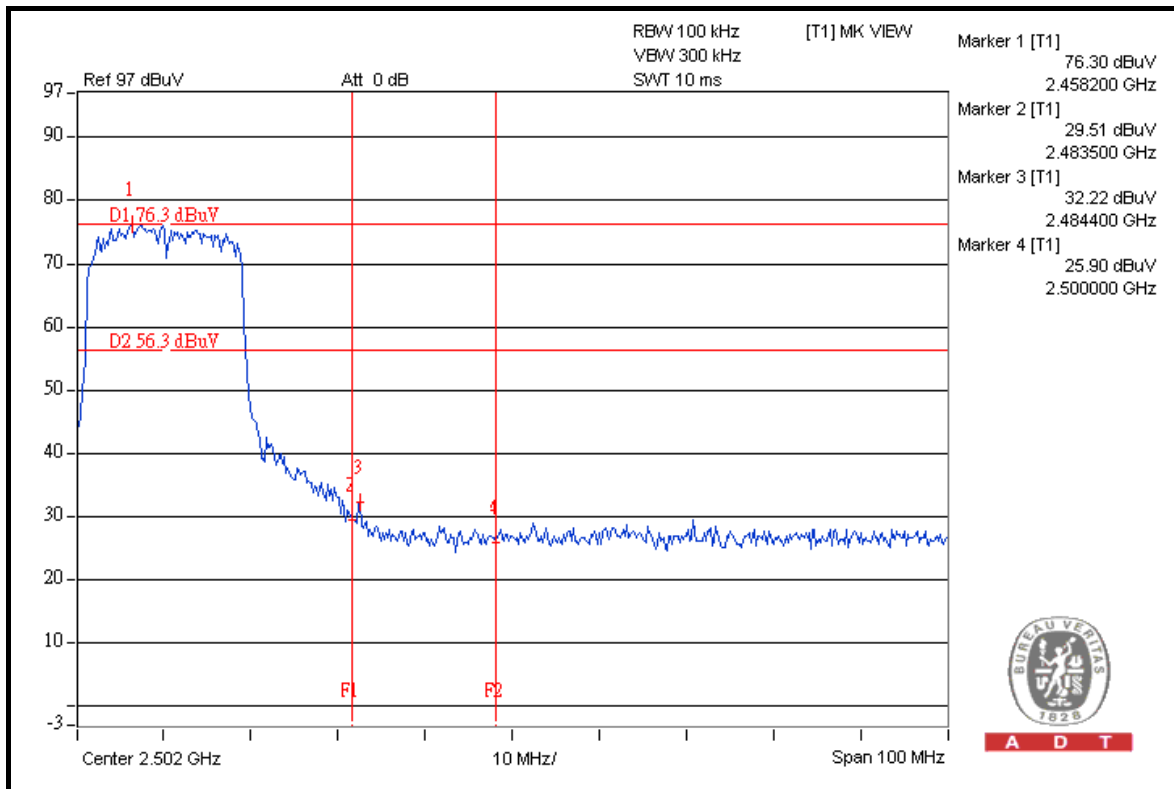
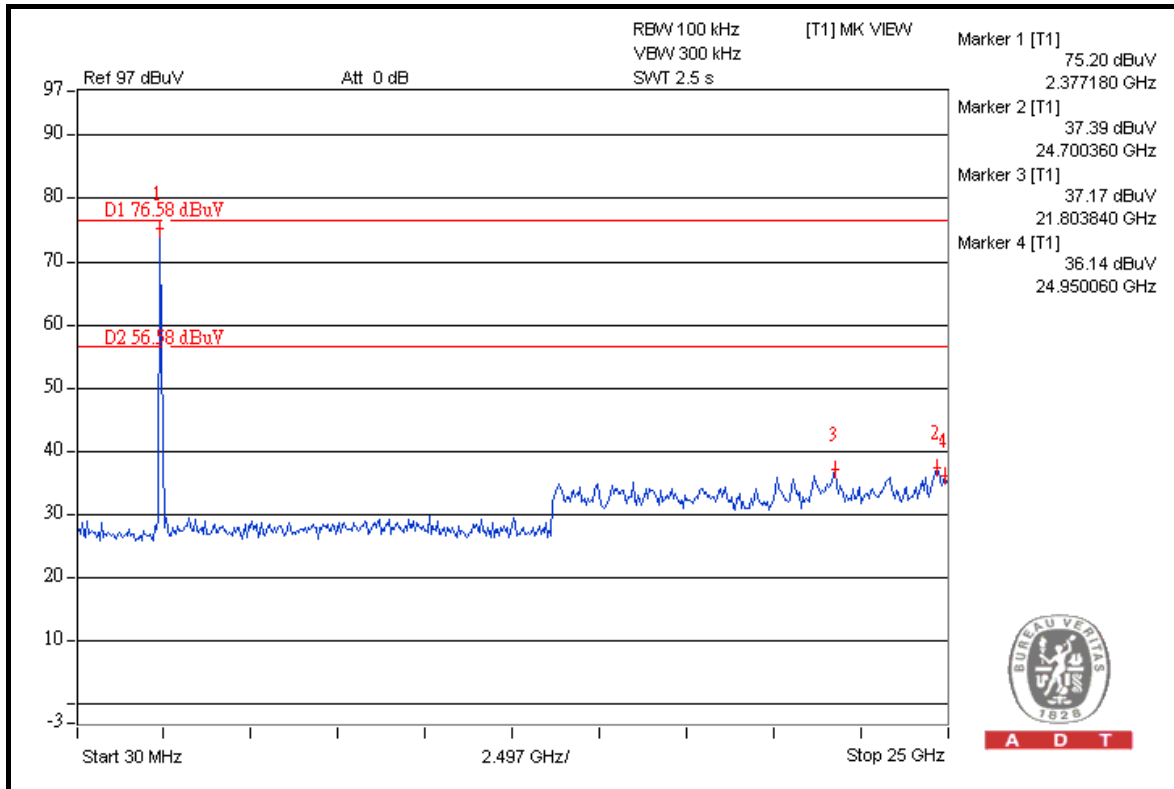



A D T

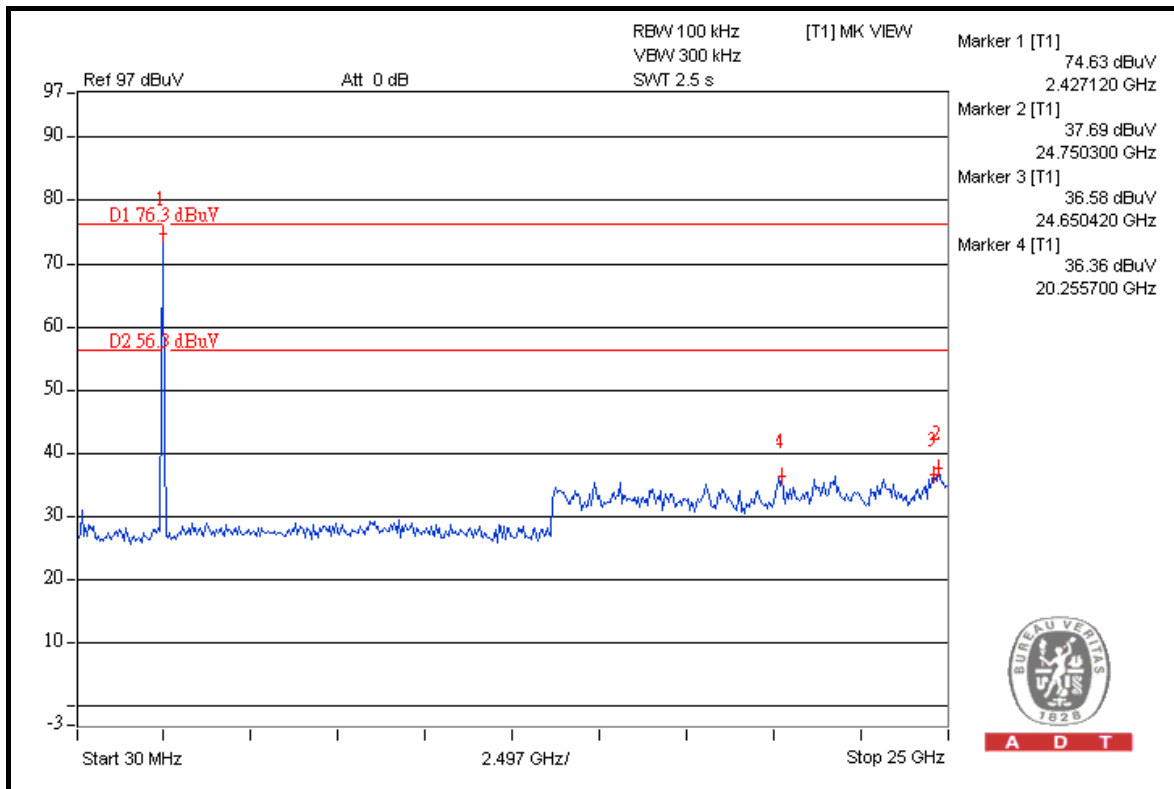
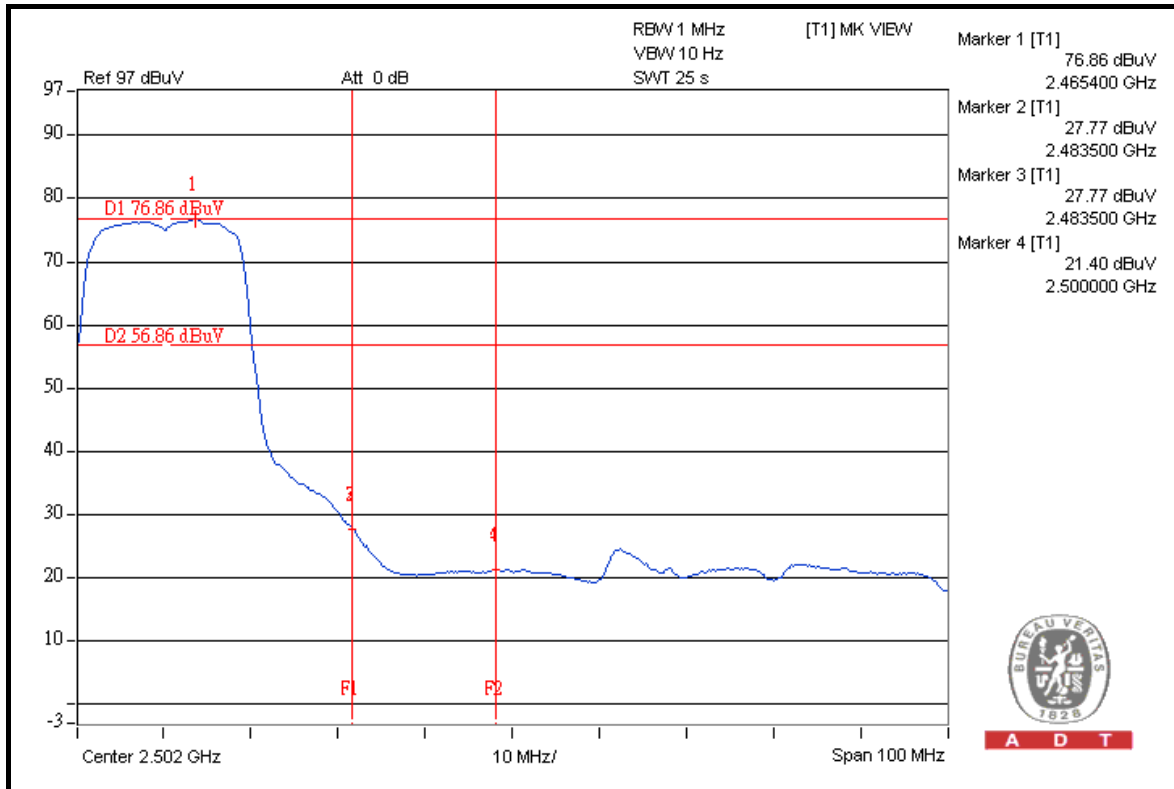



A D T

DRAFT 802.11n (40MHz) OFDM MODULATION

NOTE 1: The band edge emission plot on the next page shows 41.92dBc between carrier maximum power and local maximum emission in restrict band (2.38240GHz). The emission of carrier strength list in the test result of channel 1 at the item 4.1.7 is 105.75dBuV/m (Peak), so the maximum field strength in restrict band is $105.75 - 41.92 = 63.83$ dBuV/m which is under 74dBuV/m limit.

The band edge emission plot of on the next page shows 47.54dBc between carrier maximum power and local maximum emission in restrict band (2.38960GHz). The emission of carrier strength list in the test result of channel 1 at the item 4.1.7 is 95.69dBuV/m (Average), so the maximum field strength in restrict band is $95.69 - 47.54 = 48.15$ dBuV/m which is under 54dBuV/m limit.

NOTE 2: The band edge emission plot on the next second page shows 36.45dBc between carrier maximum power and local maximum emission in restrict band (2.48400GHz). The emission of carrier strength list in the test result of channel 7 at the item 4.1.7 is 107.64dBuV/m (Peak), so the maximum field strength in restrict band is $107.64 - 39.45 = 69.33$ dBuV/m which is under 74dBuV/m limit.

The band edge emission plot on the next third page shows 42.72dBc between carrier maximum power and local maximum emission in restrict band (2.48350GHz). The emission of carrier strength list in the test result of channel 7 at the item 4.1.7 is 95.66dBuV/m (Average), so the maximum field strength in restrict band is $95.66 - 42.72 = 52.94$ dBuV/m which is under 54dBuV/m limit.



A D T

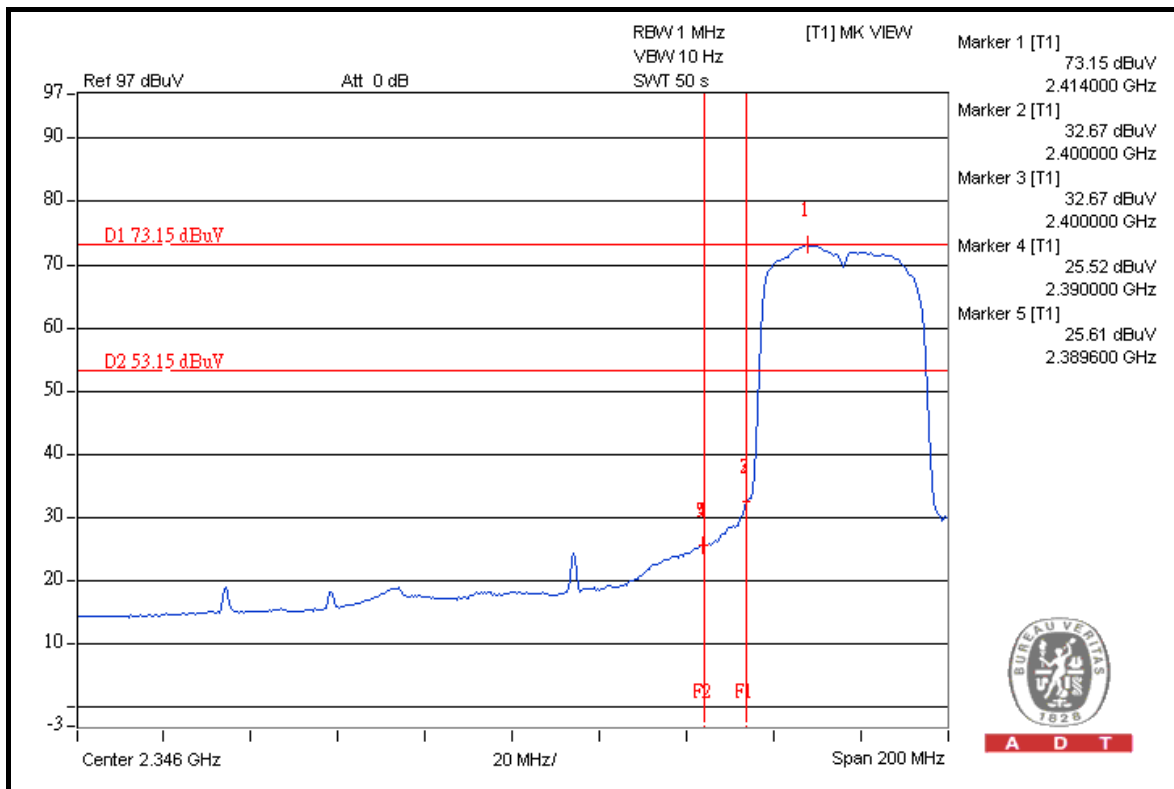
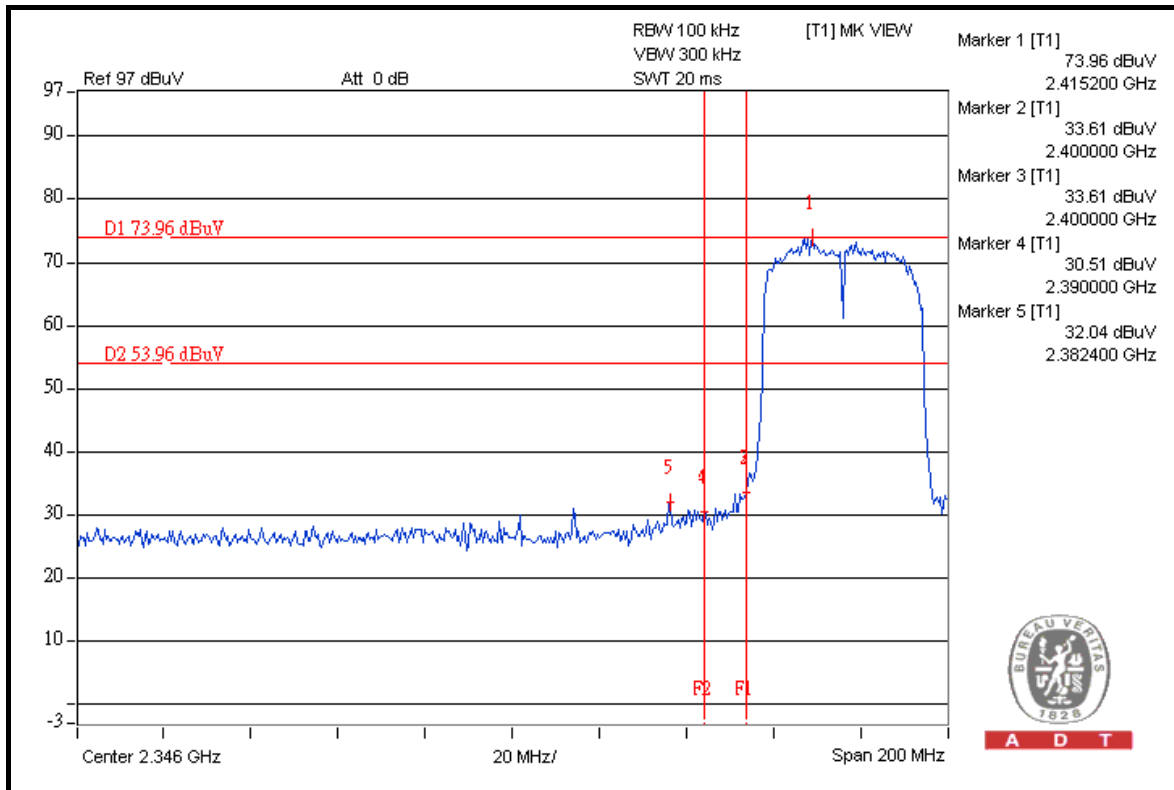



A D T

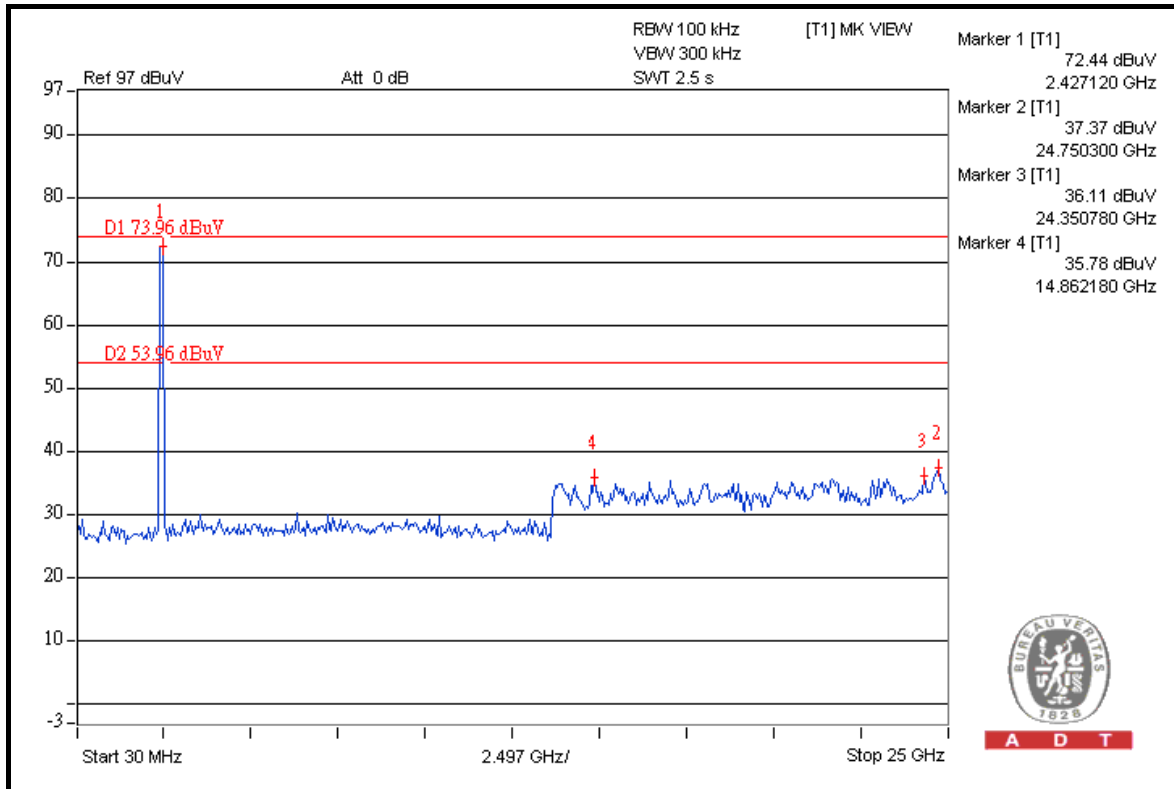

A D T

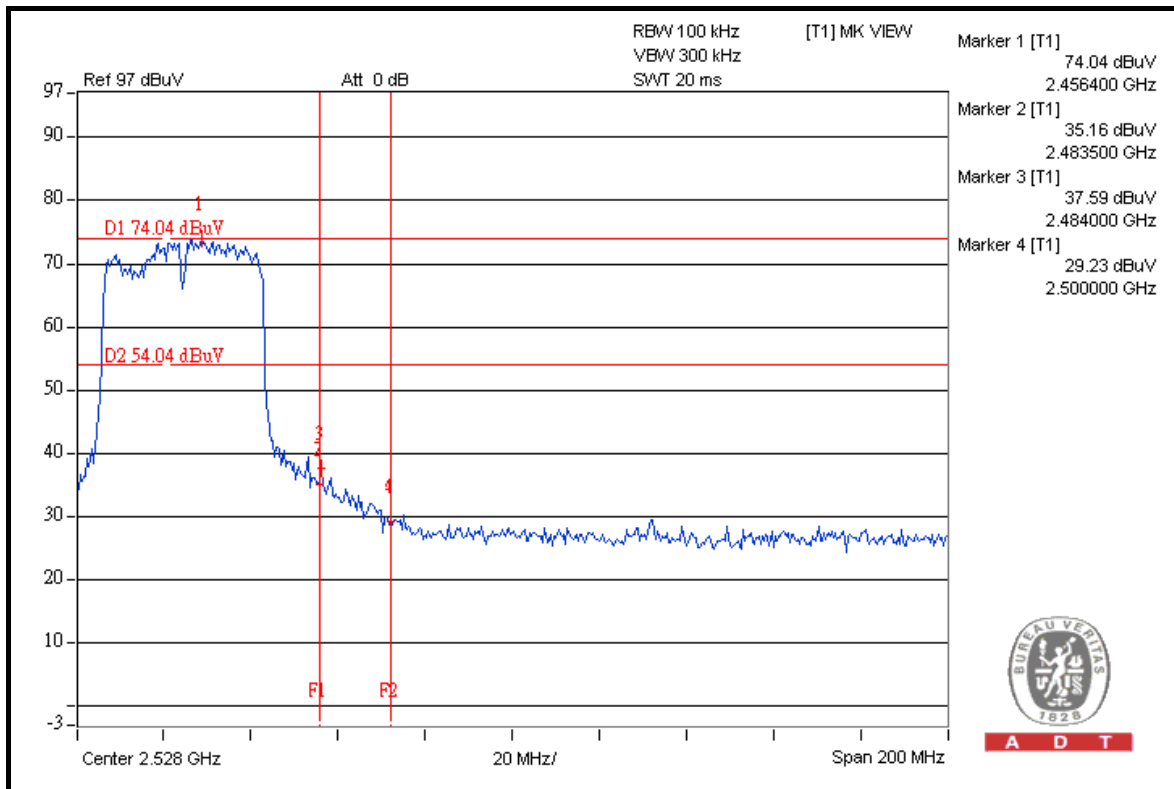

A D T



A D T

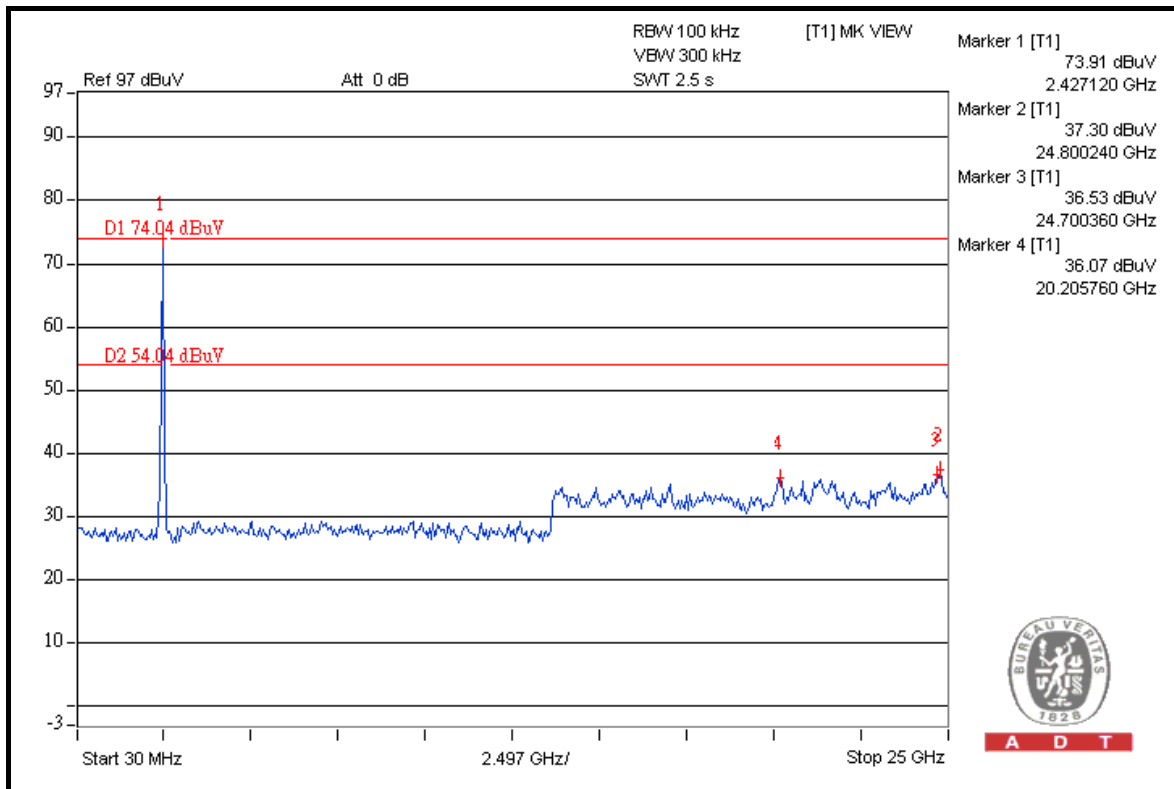
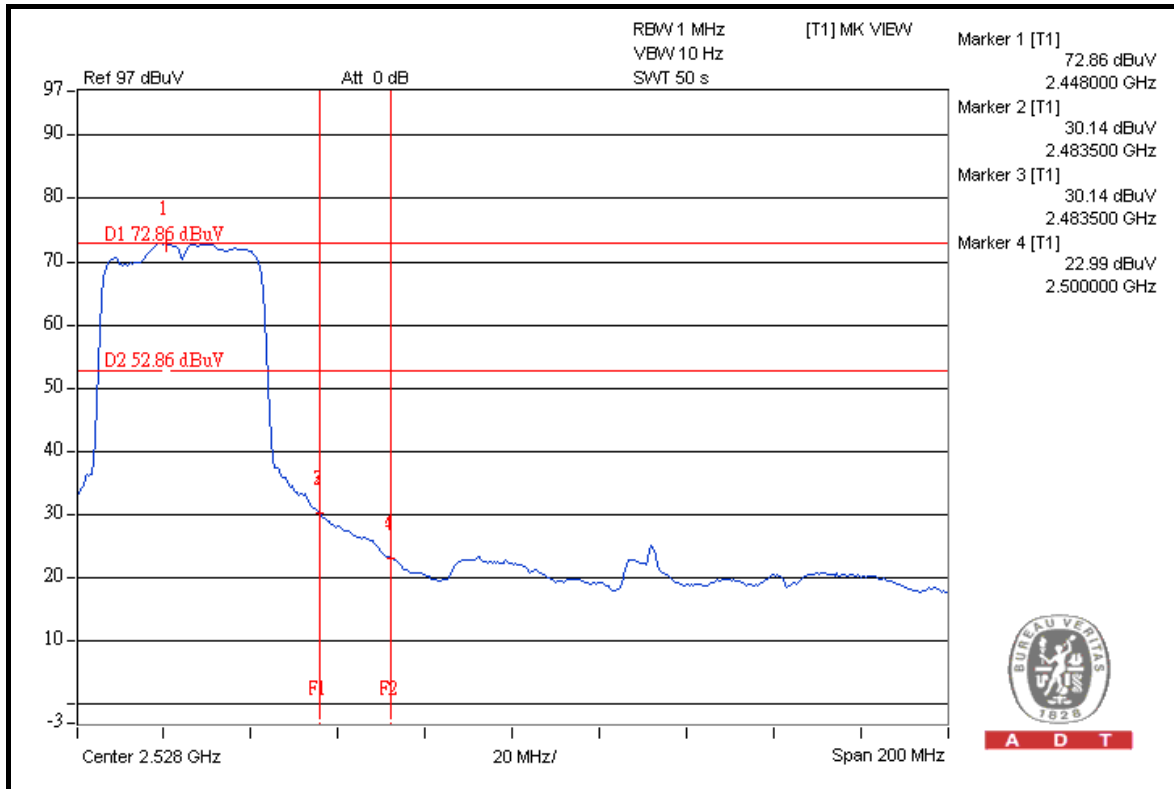



A D T

4.7 ANTENNA REQUIREMENT

4.7.1 STANDARD APPLICABLE

For intentional device, according to FCC 47 CFR Section 15.203, an intentional radiator shall be designed to ensure that no antenna other than that furnished by the responsible party shall be used with the device.

And according to FCC 47 CFR Section 15.247 (b), if transmitting antennas of directional gain greater than 6dBi are used, the power shall be reduced by the amount in dB that the directional gain of the antenna exceeds 6dBi.

4.7.2 ANTENNA CONNECTED CONSTRUCTION

The antenna used in this product is PIFA antenna without any connector. The maximum gain of the antenna is 3dBi.



A D T

5. PHOTOGRAPHS OF THE TEST CONFIGURATION

Please refer to the attached file (Test Setup Photo).



A D T

6. INFORMATION ON THE TESTING LABORATORIES

We, Bureau Veritas Consumer Products Services (H.K.) Ltd., Taoyuan Branch, were founded in 1988 to provide our best service in EMC, Radio, Telecom and Safety consultation. Our laboratories are accredited and approved by the following approval agencies according to ISO/IEC 17025.

USA	FCC, NVLAP
Germany	TUV Rheinland
Japan	VCCI
Norway	NEMKO
Canada	INDUSTRY CANADA, CSA
R.O.C.	TAF, BSMI, NCC
Netherlands	Telefication
Singapore	GOST-ASIA(MOU)
Russia	CERTIS(MOU)

Copies of accreditation certificates of our laboratories obtained from approval agencies can be downloaded from our web site:

www.adt.com.tw/index.5/phtml. If you have any comments, please feel free to contact us at the following:

Linko EMC/RF Lab:

Tel: 886-2-26052180

Fax: 886-2-26051924

Hsin Chu EMC/RF Lab:

Tel: 886-3-5935343

Fax: 886-3-5935342

Hwa Ya EMC/RF/Safety Telecom Lab:

Tel: 886-3-3183232

Fax: 886-3-3185050

Web Site: www.adt.com.tw

The address and road map of all our labs can be found in our web site also.



A D T

7. APPENDIX A - MODIFICATIONS RECORDERS FOR ENGINEERING CHANGES TO THE EUT BY THE LAB

No any modifications are made to the EUT by the lab during the test.

---END---