

# FCC Radio Test Report

## FCC ID: KA2CS8515LHA1

This report concerns (check one):  Original Grant  Class I Change  Class II Change

**Project No.** : 1810H009  
**Equipment** : HD Pan & Tilt Wi-Fi Camera  
**Test Model** : DCS-8515LH  
**Series Model** : N/A  
**Applicant** : D-Link Corporation  
**Address** : 17595 Mt. Herrmann, Fountain Valley, California,  
United States 92708

**Date of Receipt** : Oct. 31, 2018  
**Date of Test** : Nov. 19, 2018 ~ Dec. 07, 2018  
**Issued Date** : Feb. 19, 2019  
**Tested by** : BTL Inc.

**Testing Engineer** : Kai Xu  
(Kai Xu)

**Technical Manager** : David Mao  
(David Mao)

**Authorized Signatory** : Steven Lu  
(Steven Lu)

# **B T L I N C .**

No.3, Jinshagang 1st Road, Shixia, Dalang Town, Dongguan,  
Guangdong, China.

TEL: +86-769-8318-3000 FAX: +86-769-8319-6000



Certificate #5123.02

## Declaration

**BTL** represents to the client that testing is done in accordance with standard procedures as applicable and that test instruments used has been calibrated with standards traceable to international standard(s) and/or national standard(s).

**BTL's** reports apply only to the specific samples tested under conditions. It is manufacture's responsibility to ensure that additional production units of this model are manufactured with the identical electrical and mechanical components. **BTL** shall have no liability for any declarations, inferences or generalizations drawn by the client or others from **BTL** issued reports.

The report must not be used by the client to claim product certification, approval, or endorsement by NVLAP, NIST, A2LA or any agency of the U.S. Government.

This report is the confidential property of the client. As a mutual protection to the clients, the public and ourselves, the test report shall not be reproduced, except in full, without our written approval.

**BTL's** laboratory quality assurance procedures are in compliance with the **ISO/IEC 17025** requirements, and accredited by the conformity assessment authorities listed in this test report.

**BTL** is not responsible for the sampling stage, so the results only apply to the sample as received.

The information, data and test plan are provided by manufacturer, so it is manufacturer's responsibility to ensure that the apparatus meets the essential requirements in all the possible configurations as representative of its intended use.

## Limitation

For the use of the authority's logo is limited unless the Test Standard(s)/Scope(s)/Item(s) mentioned in this test report is (are) included in the conformity assessment authorities acceptance respective.

**Table of Contents****Page**

<b>REPORT ISSUED HISTORY</b>	<b>5</b>
<b>1 . GENERAL SUMMARY</b>	<b>6</b>
<b>2 . SUMMARY OF TEST RESULTS</b>	<b>7</b>
2.1 TEST FACILITY	8
2.2 MEASUREMENT UNCERTAINTY	8
<b>3 . GENERAL INFORMATION</b>	<b>9</b>
3.1 GENERAL DESCRIPTION OF EUT	9
3.2 DESCRIPTION OF TEST MODES	10
3.3 TABLE OF PARAMETERS OF TEXT SOFTWARE SETTING	12
3.4 BLOCK DIAGRAM SHOWING THE CONFIGURATION OF SYSTEM TESTED	13
3.5 DESCRIPTION OF SUPPORT UNITS	13
<b>4 . EMC EMISSION TEST</b>	<b>14</b>
4.1 CONDUCTED EMISSION MEASUREMENT	14
4.1.1 POWER LINE CONDUCTED EMISSION LIMITS	14
4.1.2 TEST PROCEDURE	14
4.1.3 DEVIATION FROM TEST STANDARD	14
4.1.4 TEST SETUP	15
4.1.5 EUT OPERATING CONDITIONS	15
4.1.6 EUT TEST CONDITIONS	15
4.1.7 TEST RESULTS	15
4.2 RADIATED EMISSION MEASUREMENT	16
4.2.1 RADIATED EMISSION LIMITS	16
4.2.2 TEST PROCEDURE	17
4.2.3 DEVIATION FROM TEST STANDARD	17
4.2.4 TEST SETUP	18
4.2.5 EUT OPERATING CONDITIONS	19
4.2.6 EUT TEST CONDITIONS	19
4.2.7 TEST RESULTS (9 KHZ TO 30 MHZ)	19
4.2.8 TEST RESULTS (30 MHZ TO 1000 MHZ)	19
4.2.9 TEST RESULTS (ABOVE 1000 MHZ)	19
<b>5 . BANDWIDTH TEST</b>	<b>20</b>
5.1 APPLIED PROCEDURES	20
5.1.1 TEST PROCEDURE	20
5.1.2 DEVIATION FROM STANDARD	20
5.1.3 TEST SETUP	20
5.1.4 EUT OPERATION CONDITIONS	20
5.1.5 EUT TEST CONDITIONS	20

<b>Table of Contents</b>	<b>Page</b>
5.1.6 TEST RESULTS	20
<b>6 . MAXIMUM OUTPUT POWER TEST</b>	<b>21</b>
6.1 APPLIED PROCEDURES / LIMIT	21
6.1.1 TEST PROCEDURE	21
6.1.2 DEVIATION FROM STANDARD	21
6.1.3 TEST SETUP	21
6.1.4 EUT OPERATION CONDITIONS	21
6.1.5 EUT TEST CONDITIONS	21
6.1.6 TEST RESULTS	21
<b>7 . ANTENNA CONDUCTED SPURIOUS EMISSION</b>	<b>22</b>
7.1 APPLIED PROCEDURES / LIMIT	22
7.1.1 TEST PROCEDURE	22
7.1.2 DEVIATION FROM STANDARD	22
7.1.3 TEST SETUP	22
7.1.4 EUT OPERATION CONDITIONS	22
7.1.5 EUT TEST CONDITIONS	22
7.1.6 TEST RESULTS	22
<b>8 . POWER SPECTRAL DENSITY TEST</b>	<b>23</b>
8.1 APPLIED PROCEDURES / LIMIT	23
8.1.1 TEST PROCEDURE	23
8.1.2 DEVIATION FROM STANDARD	23
8.1.3 TEST SETUP	23
8.1.4 EUT OPERATION CONDITIONS	23
8.1.5 EUT TEST CONDITIONS	23
8.1.6 TEST RESULTS	23
<b>9 . MEASUREMENT INSTRUMENTS LIST</b>	<b>24</b>
<b>10 . EUT TEST PHOTO</b>	<b>26</b>
<b>APPENDIX A - CONDUCTED EMISSION</b>	<b>30</b>
<b>APPENDIX B - RADIATED EMISSION (9 KHZ TO 30 MHZ)</b>	<b>35</b>
<b>APPENDIX C - RADIATED EMISSION (30 MHZ TO 1000 MHZ)</b>	<b>44</b>
<b>APPENDIX D - RADIATED EMISSION (ABOVE 1000 MHZ)</b>	<b>57</b>
<b>APPENDIX E - BANDWIDTH</b>	<b>106</b>
<b>APPENDIX F - MAXIMUM OUTPUT POWER</b>	<b>115</b>
<b>APPENDIX G - ANTENNA CONDUCTED SPURIOUS EMISSION</b>	<b>117</b>
<b>APPENDIX H - POWER SPECTRAL DENSITY</b>	<b>142</b>

### REPORT ISSUED HISTORY

Report Version	Description	Issued Date
R00	Original Issue.	Feb. 19, 2019

## 1. GENERAL SUMMARY

Equipment : HD Pan & Tilt Wi-Fi Camera  
Brand Name : D-Link  
Test Model : DCS-8515LH  
Series Model : N/A  
Applicant : D-Link Corporation  
Manufacturer : D-Link Corporation  
Address : 17595 Mt. Herrmann, Fountain Valley, California, United States 92708  
Date of Test : Nov. 19, 2018 ~ Dec. 07, 2018  
Test Sample : Engineering Sample No.: B181100202  
Standard(s) : FCC Part15, Subpart C (15.247) / ANSI C63.10-2013

The above equipment has been tested and found compliance with the requirement of the relative standards by BTL Inc.

The test data, data evaluation, and equipment configuration contained in our test report (Ref No. BTL-FCCP-3-1810H009) were obtained utilizing the test procedures, test instruments, test sites that has been accredited by the Authority of A2LA according to the ISO/IEC 17025 quality assessment standard and technical standard(s).

**Test results included in this report is only for the WLAN 2.4G part.**

## 2. SUMMARY OF TEST RESULTS

Test procedures according to the technical standard(s):

Applied Standard(s): FCC Part15 (15.247) , Subpart C			
Standard(s) Section	Test Item	Judgment	Remark
15.207	Conducted Emission	PASS	
15.247(d)	Antenna conducted Spurious Emission	PASS	
15.247(a)(2)	6 dB Bandwidth	PASS	
15.247(b)(3)	Maximum Output Power	PASS	
15.247(e)	Power Spectral Density	PASS	
15.203	Antenna Requirement	PASS	
15.247(d)/ 15.205/ 15.209	Transmitter Radiated Emissions	PASS	

Note:

(1) "N/A" denotes test is not applicable in this test report.

## 2.1 TEST FACILITY

The test facilities used to collect the test data in this report is at the location of No.3,Jinshagang 1st Road, Shixia, Dalang Town, Dongguan, Guangdong, China.

BTL's test firm number for FCC: 854385

BTL's designation number for FCC: CN5020

## 2.2 MEASUREMENT UNCERTAINTY

The measurement uncertainty figures shall be calculated according the methods described in the ETSI TR 100 028 and shall correspond to an expansion factor (coverage factor)  $k=1.96$  or  $k=2$ (which provide confidence levels of respectively 90% and 95.45% in the case where the distributions characterizing the actual measurement uncertainties are normal (Gaussian)). Measurement Uncertainty for a Level of Confidence of 95 %,  $U=2xUc(y)$ .

The BTL measurement uncertainty as below table:

### A. Conducted Measurement:

Test Site	Method	Measurement Frequency Range	U, (dB)
DG-C02	CISPR	150 kHz ~ 30 MHz	2.32

### B. Radiated Measurement:

Test Site	Method	Measurement Frequency Range	Ant. H / V	U, (dB)
DG-CB03	CISPR	9 KHz~30 MHz	V	3.79
		9 KHz~30 MHz	H	3.57
		30 MHz~200 MHz	V	3.82
		30 MH~200 MHz	H	3.78
		200 MHz~1,000 MHz	V	4.10
		200 MHz~1,000 MHz	H	4.06
		1 GHz~18 GHz	V	3.12
		1 GHz~18 GHz	H	3.68
		18 GHz~40 GHz	V	4.15
		18 GHz~40 GHz	H	4.14

Note: Unless specifically mentioned, the uncertainty of measurement has not been taken into account to declare the compliance or non-compliance to the specification.



### 3. GENERAL INFORMATION

#### 3.1 GENERAL DESCRIPTION OF EUT

Equipment	HD Pan & Tilt Wi-Fi Camera		
Brand Name	D-Link		
Test Model	DCS-8515LH		
Series Model	N/A		
Model Difference(s)	N/A		
Software Version	1		
Hardware Version	A1		
Product Description	Operation Frequency	2412 MHz ~2462 MHz	
	Modulation Technology	802.11b:DSSS 802.11g:OFDM 802.11n:OFDM	
	Bit Rate of Transmitter	802.11b: 11/5.5/2/1 Mbps 802.11g: 54/48/36/24/18/12/9/6 Mbps 802.11n: up to 150 Mbps	
	Output Power (Max.)	802.11b: 24.96 dBm 802.11g: 27.33 dBm 802.11n(20 MHz): 27.34 dBm 802.11n(40 MHz): 26.87 dBm	
Power Source	DC Voltage supplied from AC/DC adapter. #1 Model:SW-1780 #2 Model: F06W-050120SPACP L.P.S		
Power Rating	I/P:100-240V~ 50/60Hz 0.2A O/P:5.0V $\overline{=}$ 1.2A		

Note:

1. For a more detailed features description, please refer to the manufacturer's specifications or the user's manual.

2. Channel List:

CH01 - CH11 for 802.11b, 802.11g, 802.11n(20 MHz) CH03 - CH09 for 802.11n(40 MHz)							
Channel	Frequency (MHz)	Channel	Frequency (MHz)	Channel	Frequency (MHz)	Channel	Frequency (MHz)
01	2412	04	2427	07	2442	10	2457
02	2417	05	2432	08	2447	11	2462
03	2422	06	2437	09	2452		

3. Table for Filed Antenna

Ant.	Brand	Model Name	Antenna Type	Connector	Gain (dBi)
1	<b>T&amp;W</b>	N/A	Internal	N/A	3

### 3.2 DESCRIPTION OF TEST MODES

To investigate the maximum EMI emission characteristics generated from EUT, the test system was pre-scanning tested based on the consideration of following EUT operation mode or test configuration mode which possibly have effect on EMI emission level. Each of these EUT operation mode(s) or test configuration mode(s) mentioned above was evaluated respectively.

Pretest Mode	Description
Mode 1	TX B Mode Channel 01/06/11
Mode 2	TX G Mode Channel 01/06/11
Mode 3	TX N-20 MHz Mode Channel 01/06/11
Mode 4	TX N-40 MHz Mode Channel 03/06/09
Mode 5	TX Mode

The EUT system operated these modes were found to be the worst case during the pre-scanning test as following:

For Conducted Test	
Final Test Mode:	Description
Mode 5	TX Mode

For Radiated Test	
Final Test Mode:	Description
Mode 1	TX B Mode Channel 01/06/11
Mode 2	TX G Mode Channel 01/06/11
Mode 3	TX N-20 MHz Mode Channel 01/06/11
Mode 4	TX N-40 MHz Mode Channel 03/06/09

For Band Edge Test	
Final Test Mode:	Description
Mode 1	TX B Mode Channel 01/06/11
Mode 2	TX G Mode Channel 01/06/11
Mode 3	TX N-20 MHz Mode Channel 01/06/11
Mode 4	TX N-40 MHz Mode Channel 03/06/09

6 dB Spectrum Bandwidth	
Final Test Mode:	Description
Mode 1	TX B Mode Channel 01/06/11
Mode 2	TX G Mode Channel 01/06/11
Mode 3	TX N-20 MHz Mode Channel 01/06/11
Mode 4	TX N-40 MHz Mode Channel 03/06/09

Maximum Output Power	
Final Test Mode:	Description
Mode 1	TX B Mode Channel 01/06/11
Mode 2	TX G Mode Channel 01/06/11
Mode 3	TX N-20 MHz Mode Channel 01/06/11
Mode 4	TX N-40 MHz Mode Channel 03/06/09

Power Spectral Density	
Final Test Mode:	Description
Mode 1	TX B Mode Channel 01/06/11
Mode 2	TX G Mode Channel 01/06/11
Mode 3	TX N-20 MHz Mode Channel 01/06/11
Mode 4	TX N-40 MHz Mode Channel 03/06/09

**Note:**

- (1) The measurements are performed at the high, middle, low available channels.
- (2) 802.11b mode: DBPSK (1 Mbps)  
 802.11g mode: OFDM (6 Mbps)  
 802.11n HT20 mode : BPSK (6.5 Mbps)  
 802.11n HT40 mode : BPSK (13.5 Mbps)  
 For radiated emission tests, the highest output powers were set for final test.
- (3) For radiated 30 MHz to 1000 MHz test, the 802.11b is found to be the worst case and recorded.
- (4) The EUT was programmed to be in continuously transmitting mode and the transmit duty cycle is not less than 98%.

### 3.3 TABLE OF PARAMETERS OF TEXT SOFTWARE SETTING

During testing, channel & power controlling software provided by the customer was used to control the operating channel as well as the output power level. The RF output power selection is for the setting of RF output power expected by the customer and is going to be fixed on the firmware of the final end product power parameters of WLAN

Test software version	CMD		
Frequency (MHz)	2412	2437	2462
802.11b	60	61	60
802.11g	56	61	54
802.11n (20 MHz)	56	61	55
Frequency (MHz)	2422	2437	2452
802.11n (40 MHz)	55	61	56

**3.4 BLOCK DIAGRAM SHOWING THE CONFIGURATION OF SYSTEM TESTED**

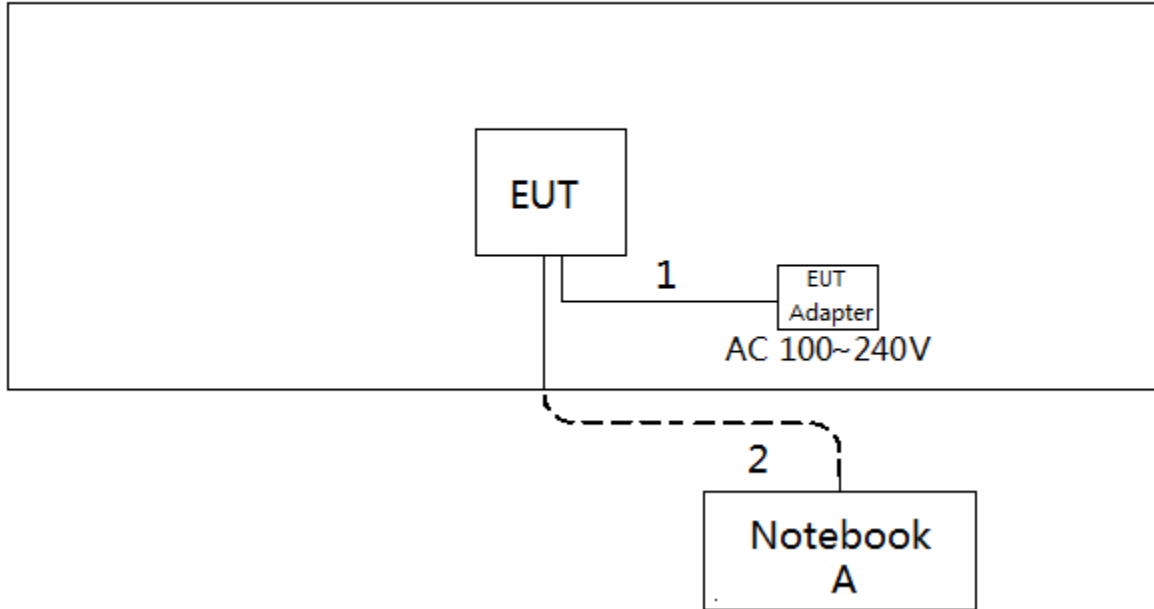

**3.5 DESCRIPTION OF SUPPORT UNITS**

The EUT has been tested as an independent unit together with other necessary accessories or support units. The following support units or accessories were used to form a representative test configuration during the tests.

Item	Equipment	Mfr/Brand	Model/Type No.	FCC ID	Series No.
A	Notebook	Lenovo	V310-14ISK	N/A	LR07GZNB

Item	Shielded Type	Ferrite Core	Length	Note
1	NO	NO	3m	DC Cable
2	NO	NO	10m	RJ45 Cable

## 4. EMC EMISSION TEST

### 4.1 CONDUCTED EMISSION MEASUREMENT

#### 4.1.1 POWER LINE CONDUCTED EMISSION LIMITS (Frequency Range 150 kHz-30 MHz)

Frequency of Emission (MHz)	Conducted Limit (dB $\mu$ V)	
	Quasi-peak	Average
0.15 - 0.50	66 to 56*	56 to 46*
0.50 - 5.0	56	46
5.0 - 30.0	60	50

Note:

- (1) The limit of " \* " decreases with the logarithm of the frequency
- (2) The test result calculated as following:  
 Measurement Value = Reading Level + Correct Factor  
 Correct Factor = Insertion Loss + Cable Loss + Attenuator Factor(if use)  
 Margin Level = Measurement Value - Limit Value

The following table is the setting of the receiver

Receiver Parameters	Setting
Attenuation	10 dB
Start Frequency	0.15 MHz
Stop Frequency	30 MHz
IF Bandwidth	9 kHz

#### 4.1.2 TEST PROCEDURE

- a. The EUT was placed 0.8 meters from the horizontal ground plane with EUT being connected to the power mains through a line impedance stabilization network (LISN). All other support equipment powered from additional LISN(s). The LISN provide 50 Ohm/ 50uH of coupling impedance for the measuring instrument.
- b. Interconnecting cables that hang closer than 40 cm to the ground plane shall be folded back and forth in the center forming a bundle 30 to 40 cm long.
- c. I/O cables that are not connected to a peripheral shall be bundled in the center. The end of the cable may be terminated, if required, using the correct terminating impedance. The overall length shall not exceed 1 m.
- d. LISN at least 80 cm from nearest part of EUT chassis.
- e. For the actual test configuration, please refer to the related Item -EUT Test Photos.

#### 4.1.3 DEVIATION FROM TEST STANDARD

No deviation

**4.1.4 TEST SETUP**

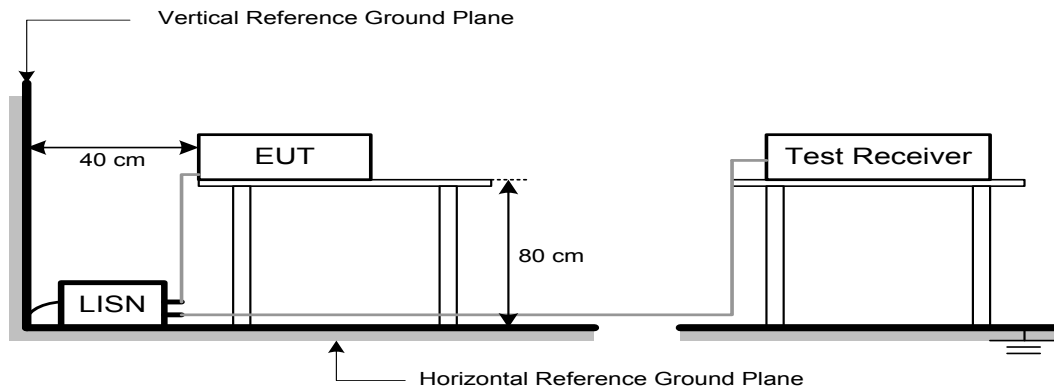

**4.1.5 EUT OPERATING CONDITIONS**

The EUT was placed on the test table and programmed in normal function.

**4.1.6 EUT TEST CONDITIONS**

Temperature: 25°C    Relative Humidity: 55%    Test Voltage: AC 120V/60Hz

**4.1.7 TEST RESULTS**

Please refer to the Appendix A.

## 4.2 RADIATED EMISSION MEASUREMENT

### 4.2.1 RADIATED EMISSION LIMITS

In case the emission fall within the restricted band specified on 15.205(a), then the 15.209(a) limit in the table below has to be followed.

#### LIMITS OF RADIATED EMISSION MEASUREMENT (9 kHz-1000 MHz)

Frequency (MHz)	Field Strength (microvolts/meter)	Measurement Distance (meters)
0.009~0.490	2400/F(kHz)	300
0.490~1.705	24000/F(kHz)	30
1.705~30.0	30	30
30~88	100	3
88~216	150	3
216~960	200	3
960~1000	500	3

#### LIMITS OF RADIATED EMISSION MEASUREMENT (Above 1000 MHz)

Frequency (MHz)	(dBuV/m) (at 3 meters)	
	Peak	Average
Above 1000	74	54

Note:

- (1) The limit for radiated test was performed according to FCC PART 15C.
- (2) The tighter limit applies at the band edges.
- (3) Emission level (dBuV/m)=20log Emission level (uV/m).
- (4) The test result calculated as following:  
 Measurement Value = Reading Level + Correct Factor  
 Correct Factor = Antenna Factor + Cable Loss - Amplifier Gain(if use)  
 Margin Level = Measurement Value - Limit Value



Spectrum Parameter	Setting
Attenuation	Auto
Start Frequency	1000 MHz
Stop Frequency	10th carrier harmonic
RBW / VBW (Emission in restricted band)	1 MHz / 3 MHz for Peak, 1 MHz / 1/T for Average

Receiver Parameter	Setting
Attenuation	Auto
Start ~ Stop Frequency	9 kHz~90 kHz for PK/AVG detector
Start ~ Stop Frequency	90 kHz~110 kHz for QP detector
Start ~ Stop Frequency	110 kHz~490 kHz for PK/AVG detector
Start ~ Stop Frequency	490 kHz~30 MHz for QP detector
Start ~ Stop Frequency	30 MHz~1000 MHz for QP detector

#### 4.2.2 TEST PROCEDURE

- The measuring distance of 3 m shall be used for measurements. The EUT was placed on the top of a rotating table 0.8 meter above the ground at a 3 meter semi-anechoic chamber. The table was rotated 360 degrees to determine the position of the highest radiation.(below 1 GHz)
- The measuring distance of 3 m shall be used for measurements. The EUT was placed on the top of a rotating table 1.5 meter above the ground at a 3 meter semi-anechoic chamber. The table was rotated 360 degrees to determine the position of the highest radiation.(above 1 GHz)
- The height of the equipment or of the substitution antenna shall be 0.8m or 1.5m; the height of the test antenna shall vary between 1 m to 4 m. Both horizontal and vertical polarizations of the antenna are set to make the measurement.
- For each suspected emission, the EUT was arranged to its worst case and then the antenna was tuned to heights find the maximum reading (used Bore sight function).
- The receiver system was set to peak and average detect function and specified bandwidth with maximum hold mode when the test frequency is above 1 GHz.
- The initial step in collecting radiated emission data is a receiver peak detector mode pre-scanning the measurement frequency range. Significant peaks are then marked and then Quasi Peak detector mode re-measured.
- All readings are Peak unless otherwise stated QP in column of Note. Peak denotes that the Peak reading compliance with the QP Limits and then QP Mode measurement didn't perform. (below 1 GHz)
- All readings are Peak Mode value unless otherwise stated AVG in column of Note. If the Peak Mode Measured value compliance with the Peak Limits and lower than AVG Limits, the EUT shall be deemed to meet both Peak & AVG Limits and then only Peak Mode was measured, but AVG Mode didn't perform. (above 1 GHz)
- For the actual test configuration, please refer to the related Item -EUT Test Photos.

#### 4.2.3 DEVIATION FROM TEST STANDARD

No deviation

**4.2.4 TEST SETUP**

(A) Radiated Emission Test Set-Up Frequency 30 MHz-1000 MHz

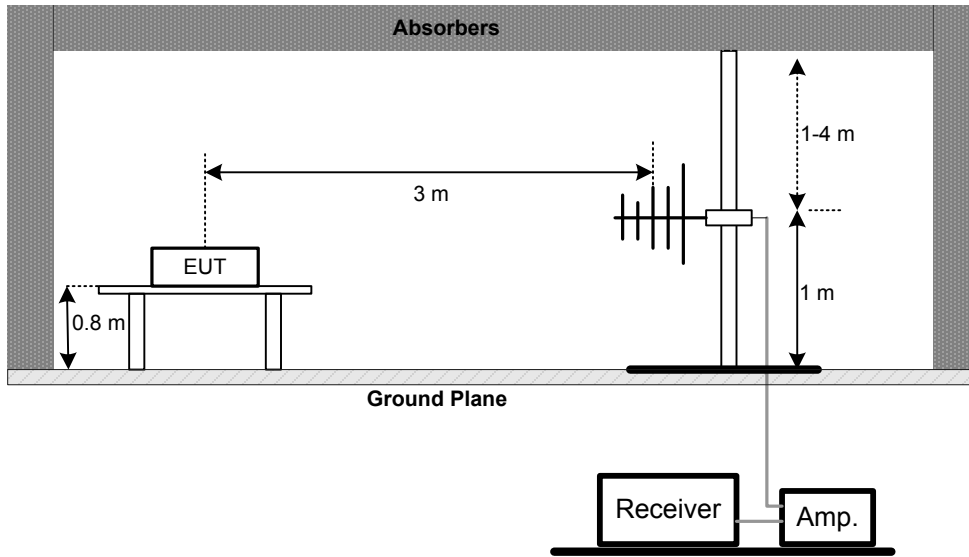

(B) Radiated Emission Test Set-Up Frequency Above 1 GHz

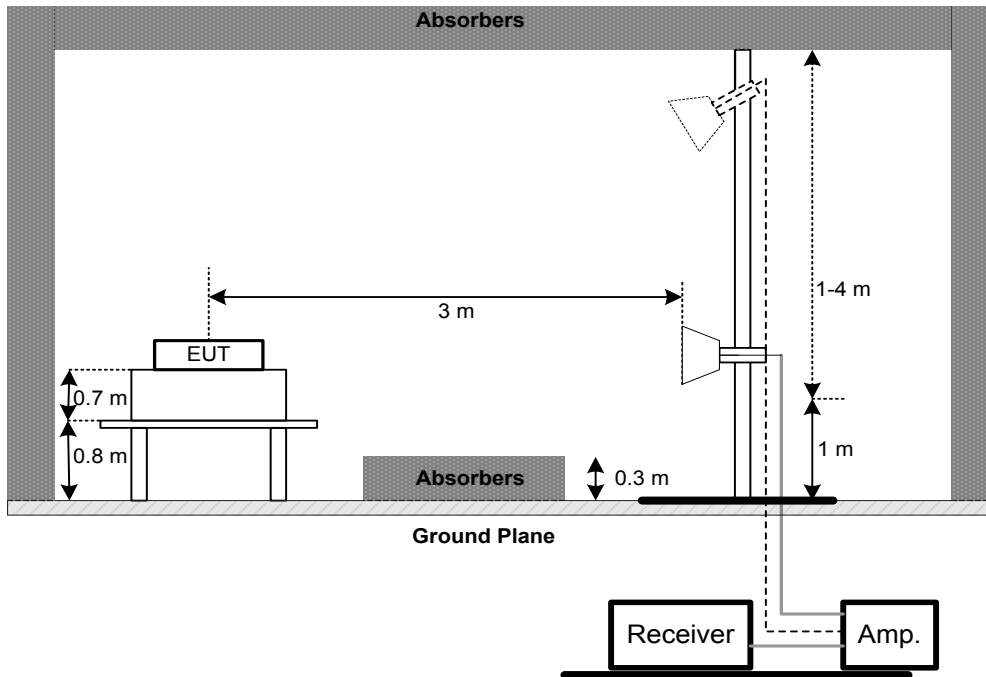

(C) For Radiated Emissions 9 kHz-30 MHz

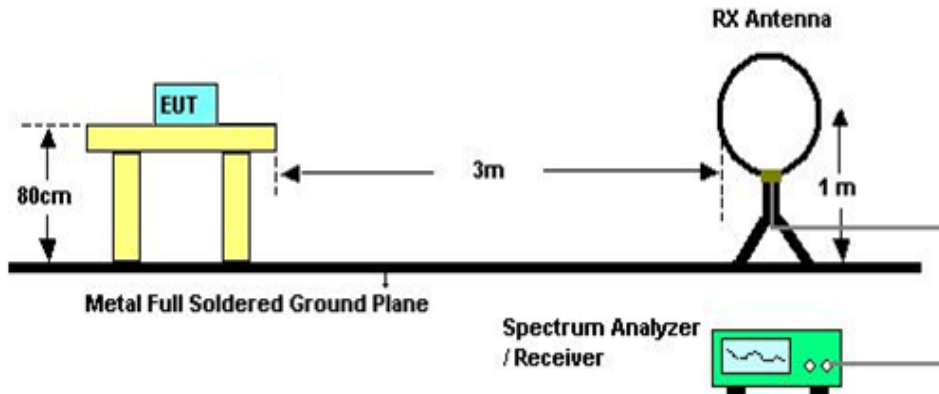

#### 4.2.5 EUT OPERATING CONDITIONS

The EUT was programmed to be in continuously transmitting mode.

#### 4.2.6 EUT TEST CONDITIONS

Temperature: 25°C    Relative Humidity: 60%    Test Voltage: AC 120V/60Hz

#### 4.2.7 TEST RESULTS (9 kHz TO 30 MHz)

Please refer to the Appendix B.

Remark:

- (1) The amplitude of spurious emissions which are attenuated by more than 20 dB below the permissible value has no need to be reported.
- (2) Distance extrapolation factor =  $40 \log (\text{specific distance} / \text{test distance})$  (dB).
- (3) Limit line = specific limits (dBuV) + distance extrapolation factor.

#### 4.2.8 TEST RESULTS (30 MHz TO 1000 MHz)

Please refer to the Appendix C.

#### 4.2.9 TEST RESULTS (ABOVE 1000 MHz)

Please refer to the Appendix D.

Remark:

- (1) No limit: This is fundamental signal, the judgment is not applicable.  
For fundamental signal judgment was referred to Peak output test.

## 5. BANDWIDTH TEST

### 5.1 APPLIED PROCEDURES

FCC Part15 (15.247) , Subpart C			
Section	Test Item	Frequency Range (MHz)	Result
15.247(a)(2)	Bandwidth	2400-2483.5	PASS

#### 5.1.1 TEST PROCEDURE

- a. The EUT was directly connected to the spectrum analyzer and antenna output port as show in the block diagram below.
- b. Spectrum Setting: RBW= 100 kHz, VBW=300 kHz, Sweep time = 2.5 ms.

#### 5.1.2 DEVIATION FROM STANDARD

No deviation.

#### 5.1.3 TEST SETUP

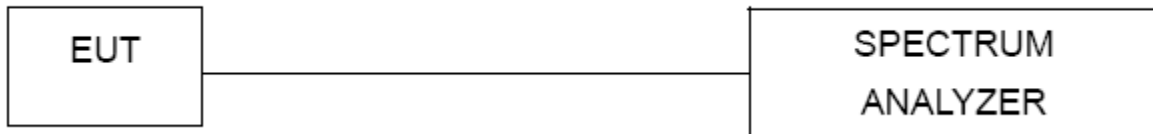

#### 5.1.4 EUT OPERATION CONDITIONS

The EUT was programmed to be in continuously transmitting mode.

#### 5.1.5 EUT TEST CONDITIONS

Temperature: 26°C    Relative Humidity: 45%    Test Voltage: AC 120V/60Hz

#### 5.1.6 TEST RESULTS

Please refer to the Appendix E.

## 6. MAXIMUM OUTPUT POWER TEST

### 6.1 APPLIED PROCEDURES / LIMIT

FCC Part15 (15.247) , Subpart C				
Section	Test Item	Limit	Frequency Range (MHz)	Result
15.247(b)(3)	Maximum Output Power	1 Watt or 30 dBm	2400-2483.5	PASS

#### 6.1.1 TEST PROCEDURE

- a. The EUT was directly connected to the power meter and antenna output port as show in the block diagram below.
- b. The maximum peak conducted output power was performed in accordance with method 11.9.1 of ANSI C63.10-2013.

#### 6.1.2 DEVIATION FROM STANDARD

No deviation.

#### 6.1.3 TEST SETUP



#### 6.1.4 EUT OPERATION CONDITIONS

The EUT was programmed to be in continuously transmitting mode.

#### 6.1.5 EUT TEST CONDITIONS

Temperature: 26°C    Relative Humidity: 45%    Test Voltage: AC 120V/60Hz

#### 6.1.6 TEST RESULTS

Please refer to the Appendix F.

## 7. ANTENNA CONDUCTED SPURIOUS EMISSION

### 7.1 APPLIED PROCEDURES / LIMIT

In any 100 kHz bandwidth outside the frequency band in which the spread spectrum or digitally modulated intentional radiator is operating, the radio frequency power that is produced by the intentional radiator shall be at least 20 dB below that in the 100 kHz bandwidth within the band that contains the highest level of the desired power, based on either an RF conducted or a radiated measurement, provided the transmitter demonstrates compliance with the peak Output Power limits. If the transmitter complies with the Output Power limits based on the use of RMS averaging over a time interval, as permitted under paragraph (b)(3) of this section, the attenuation required under this paragraph shall be 30 dB instead of 20 dB. Attenuation below the general limits specified in Section 15.209(a) is not required. In addition, radiated emissions which fall in the restricted bands, as defined in Section 15.205(a), must also comply with the radiated emission limits specified in Section 15.209(a) (see Section 15.205(c)).

#### 7.1.1 TEST PROCEDURE

- The EUT was directly connected to the spectrum analyzer and antenna output port as show in the block diagram below.
- Spectrum Setting: RBW= 100 kHz, VBW=300 kHz, Sweep time = Auto.
- Offset=antenna gain+cable loss

#### 7.1.2 DEVIATION FROM STANDARD

No deviation.

#### 7.1.3 TEST SETUP

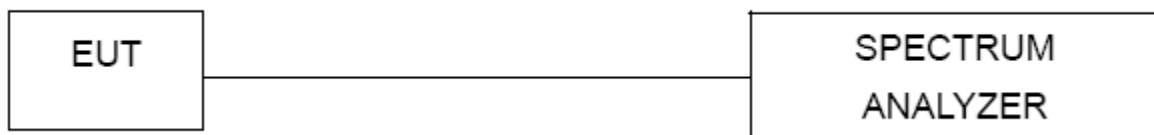

#### 7.1.4 EUT OPERATION CONDITIONS

The EUT was programmed to be in continuously transmitting mode.

#### 7.1.5 EUT TEST CONDITIONS

Temperature: 26°C    Relative Humidity: 45%    Test Voltage: AC 120V/60Hz

#### 7.1.6 TEST RESULTS

Please refer to the Appendix G.

## 8. POWER SPECTRAL DENSITY TEST

### 8.1 APPLIED PROCEDURES / LIMIT

FCC Part15 (15.247) , Subpart C				
Section	Test Item	Limit	Frequency Range (MHz)	Result
15.247(e)	Power Spectral Density	8 dBm (in any 3 kHz)	2400-2483.5	PASS

#### 8.1.1 TEST PROCEDURE

- a. The EUT was directly connected to the spectrum analyzer and antenna output port as show in the block diagram below.
- b. Spectrum Setting: RBW=3 kHz, VBW=10 kHz, Sweep time = Auto.

#### 8.1.2 DEVIATION FROM STANDARD

No deviation.

#### 8.1.3 TEST SETUP

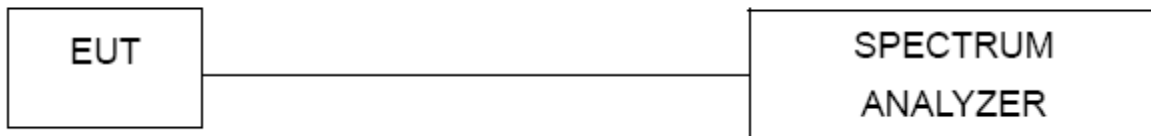

#### 8.1.4 EUT OPERATION CONDITIONS

The EUT was programmed to be in continuously transmitting mode.

#### 8.1.5 EUT TEST CONDITIONS

Temperature: 26°C    Relative Humidity: 45%    Test Voltage: AC 120V/60Hz

#### 8.1.6 TEST RESULTS

Please refer to the Appendix H.

## 9. MEASUREMENT INSTRUMENTS LIST

Conducted Emission Measurement					
Item	Kind of Equipment	Manufacturer	Type No.	Serial No.	Calibrated until
1	EMI Test Receiver	R&S	ESCI	100382	Mar. 11, 2019
2	LISN	EMCO	3816/2	52765	Mar. 11, 2019
3	50Ω Terminator	SHX	TF2-3G-A	8122901	Mar. 11, 2019
4	TWO-LINE V-NETWORK	R&S	ENV216	101447	Mar. 11, 2019
5	Measurement Software	Farad	EZ-EMC Ver.NB-03A1-01	N/A	N/A
6	Cable	N/A	RG223	12m	Mar. 23, 2019

Radiated Emission Measurement-9 kHz TO 30 MHz					
Item	Kind of Equipment	Manufacturer	Type No.	Serial No.	Calibrated until
1	Loop Antenna	EM	EM-6876-1	230	Feb. 07, 2019
2	Cable	N/A	RG 213/U	C-102	Jun. 01, 2019
3	EMI Test Receiver	R&S	ESCI	100382	Mar. 11, 2019
4	Measurement Software	Farad	EZ-EMC Ver.NB-03A1-01	N/A	N/A

Radiated Emission Measurement-30 MHz TO 1000 MHz					
Item	Kind of Equipment	Manufacturer	Type No.	Serial No.	Calibrated until
1	Antenna	Schwarbeck	VULB9160	9160-3232	Mar. 11, 2019
2	Amplifier	HP	8447D	2944A09673	Aug. 11, 2019
3	Receiver	Agilent	N9038A	MY52130039	Aug. 11, 2019
4	Cable	emci	LMR-400(30MHz-1 GHz)(8m+5m)	N/A	May 25, 2019
5	Controller	CT	SC100	N/A	N/A
6	Controller	MF	MF-7802	MF780208416	N/A
7	Measurement Software	Farad	EZ-EMC Ver.NB-03A1-01	N/A	N/A



**Radiated Emission Measurement - Above 1GHz**

Item	Kind of Equipment	Manufacturer	Type No.	Serial No.	Calibrated until
1	Double Ridged Guide Antenna	ETS	3115	75789	Mar. 11, 2019
2	Broad-Band Horn Antenna	Schwarzbeck	BBHA 9170	9170319	Jun. 30, 2019
3	Amplifier	Agilent	8449B	3008A02274	Mar. 11, 2019
4	Microwave Preamplifier With Adaptor	EMC INSTRUMENT	EMC2654045	980039 & HA01	Mar. 11, 2019
5	Receiver	Agilent	N9038A	MY52130039	Aug. 11, 2019
6	Controller	CT	SC100	N/A	N/A
7	Controller	MF	MF-7802	MF780208416	N/A
8	Cable	mitron	B10-01-01-12M	18072744	Jul. 30, 2019
9	Measurement Software	Farad	EZ-EMC Ver.NB-03A1-01	N/A	N/A

**6 dB Bandwidth**

Item	Kind of Equipment	Manufacturer	Type No.	Serial No.	Calibrated until
1	Spectrum Analyzer	R&S	FSP40	100185	Aug. 11, 2019

**Maximum output power**

Item	Kind of Equipment	Manufacturer	Type No.	Serial No.	Calibrated until
1	Power Meter	ANRITSU	ML2495A	1128009	Mar. 11, 2019
2	Pulse Power Sensor	ANRITSU	MA 2411B	1027500	Mar. 11, 2019

**Antenna Conducted Spurious Emission**

Item	Kind of Equipment	Manufacturer	Type No.	Serial No.	Calibrated until
1	Spectrum Analyzer	R&S	FSP40	100185	Aug. 11, 2019

**Power Spectral Density**

Item	Kind of Equipment	Manufacturer	Type No.	Serial No.	Calibrated until
1	Spectrum Analyzer	R&S	FSP40	100185	Aug. 11, 2019

Remark: "N/A" denotes no model name, serial no. or calibration specified.  
All calibration period of equipment list is one year.

**10. EUT TEST PHOTO****Conducted Measurement Photos**

**Radiated Measurement Photos**

**9 kHz to 30 MHz**

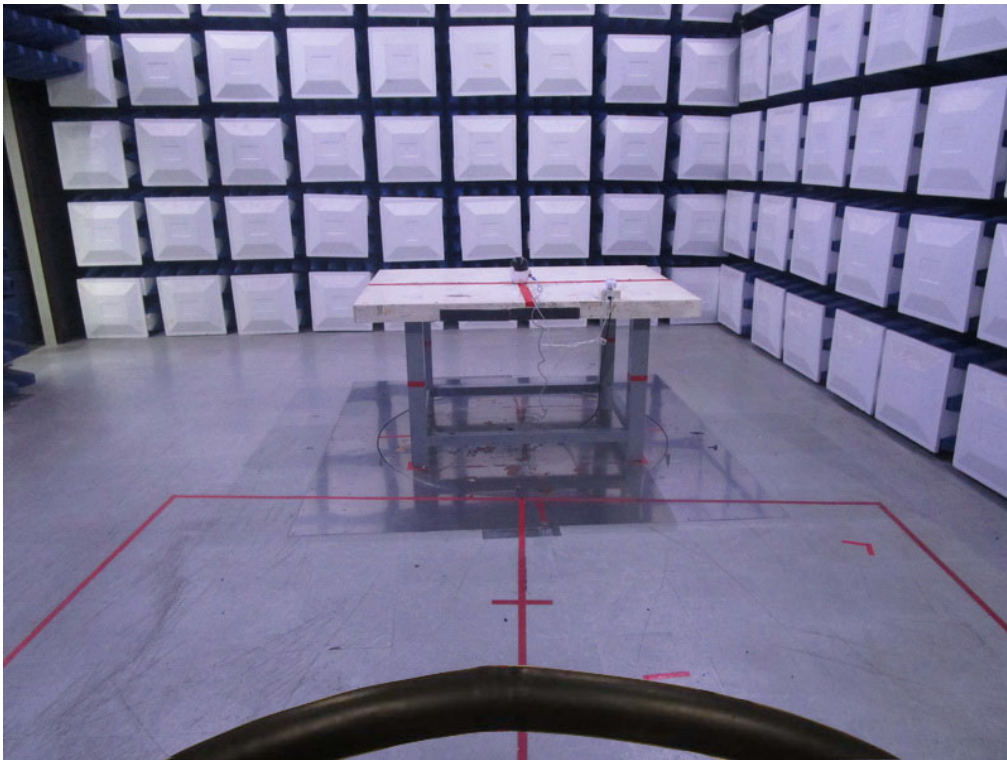

**Radiated Measurement Photos**

**30 MHz to 1000 MHz**

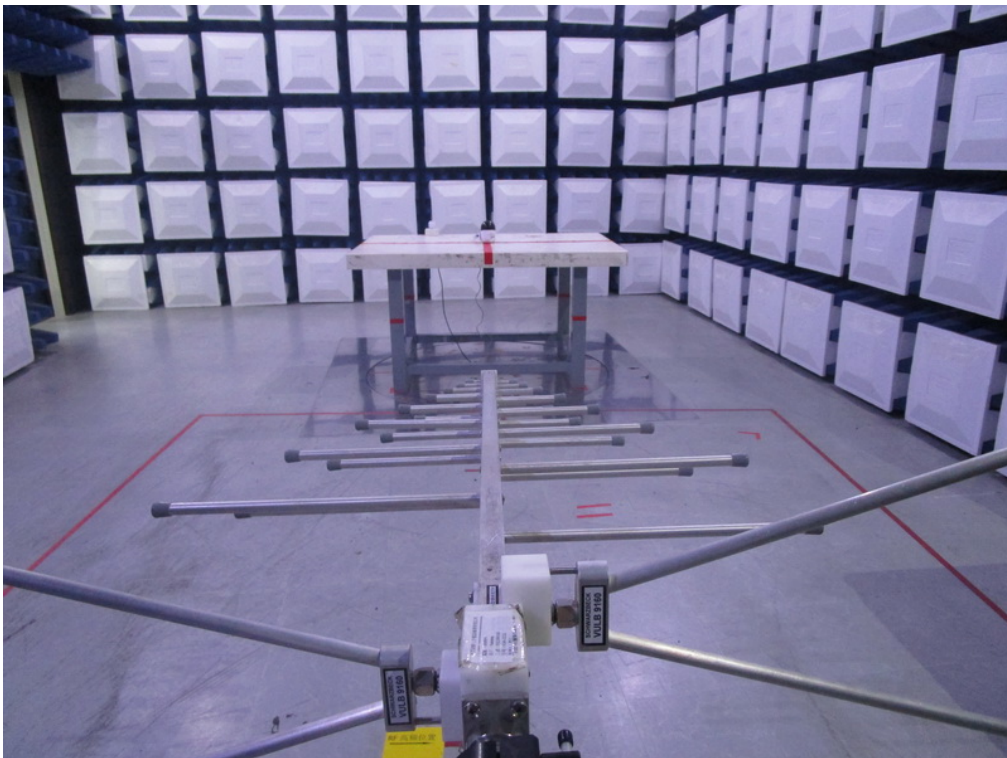
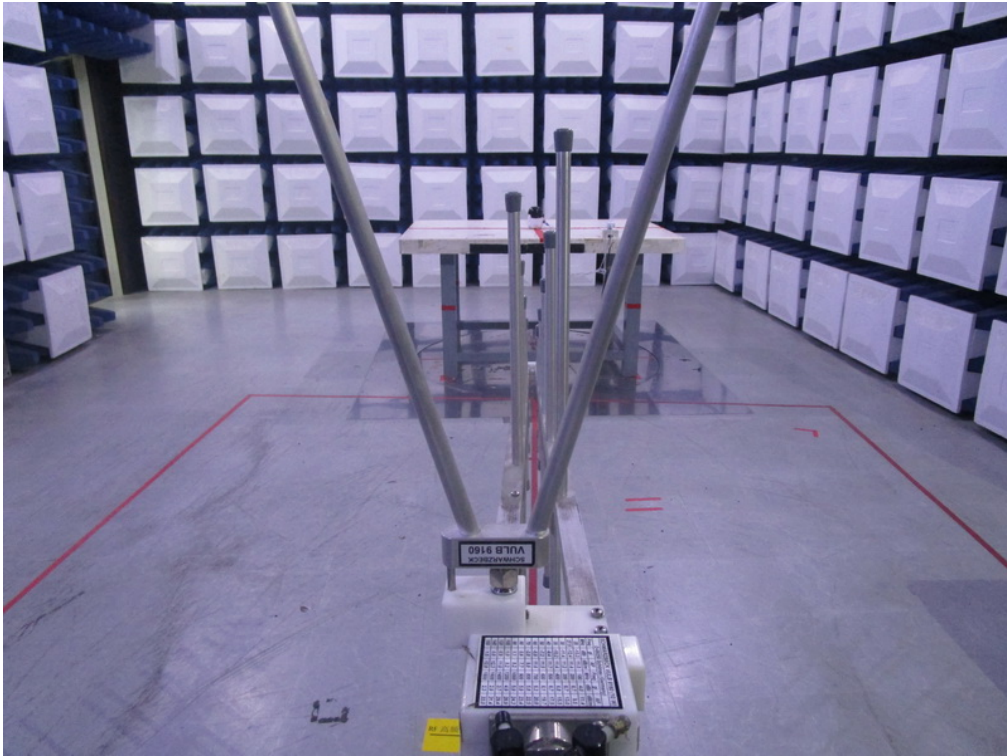

**Radiated Measurement Photos**

**Above 1000 MHz**

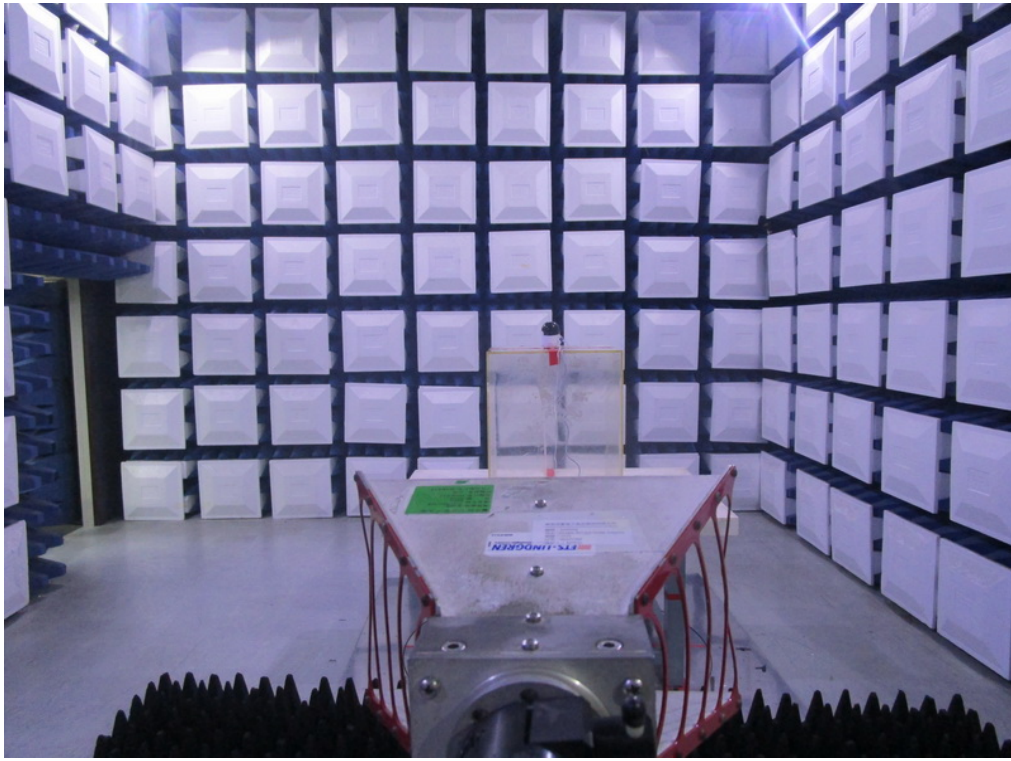

## APPENDIX A - CONDUCTED EMISSION

Test Mode: TX Mode(Adapter: F06W-050120SPACP L.P.S)

Line

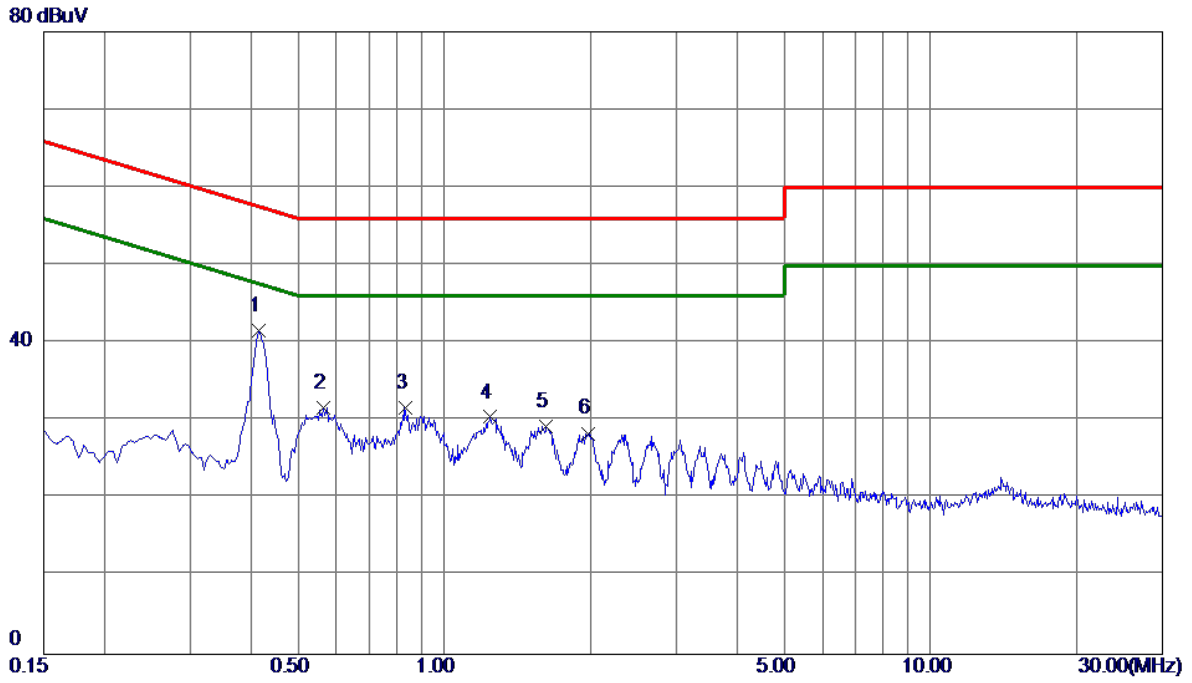

No.	Freq. MHz	Reading Level dBuV	Correct Factor dB	Measure ment dBuV	Limit dBuV	Margin dB	Detector	Comment
1 *	0.4155	31.73	9.81	41.54	57.54	-16.00	Peak	
2	0.5639	21.92	9.82	31.74	56.00	-24.26	Peak	
3	0.8295	21.82	9.91	31.73	56.00	-24.27	Peak	
4	1.2435	20.54	9.94	30.48	56.00	-25.52	Peak	
5	1.6215	19.35	9.97	29.32	56.00	-26.68	Peak	
6	1.9725	18.40	10.00	28.40	56.00	-27.60	Peak	

Test Mode: TX Mode(Adapter: F06W-050120SPACP L.P.S)

**Neutral**

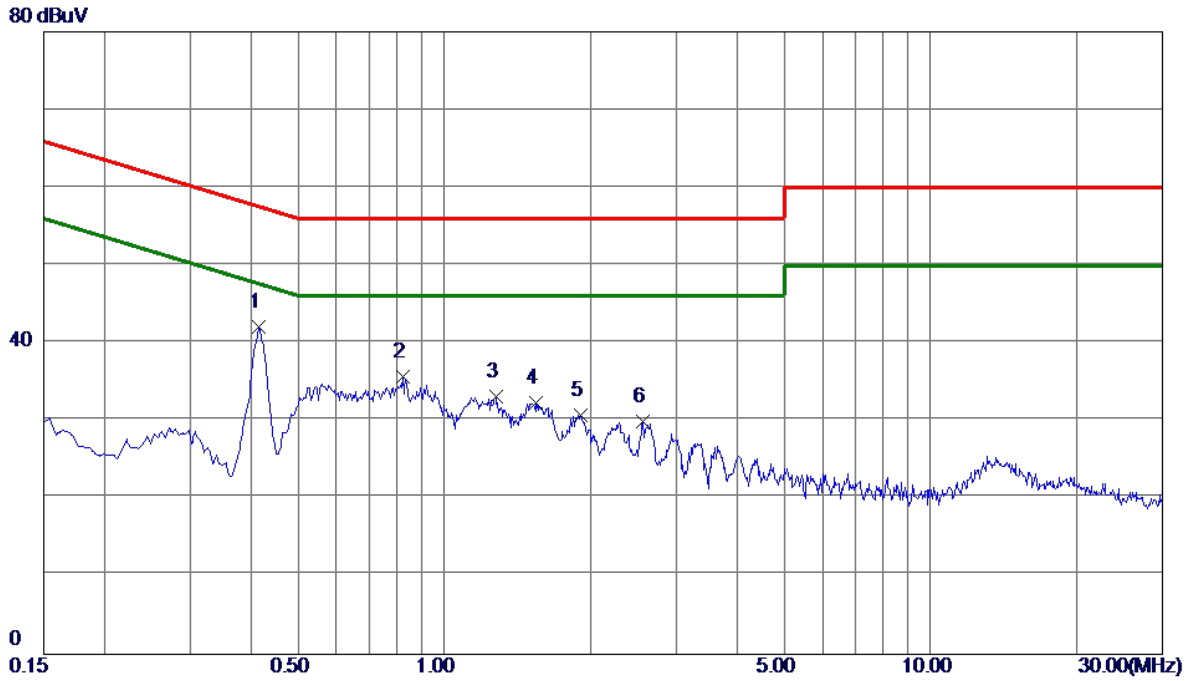

No.	Freq. MHz	Reading Level dBuV	Correct Factor dB	Measure ment dBuV	Limit dBuV	Margin dB	Detector	Comment
1 *	0.4155	32.18	9.95	42.13	57.54	-15.41	Peak	
2	0.8205	25.65	10.09	35.74	56.00	-20.26	Peak	
3	1.2750	22.94	10.14	33.08	56.00	-22.92	Peak	
4	1.5450	22.12	10.16	32.28	56.00	-23.72	Peak	
5	1.9095	20.60	10.18	30.78	56.00	-25.22	Peak	
6	2.5665	19.69	10.22	29.91	56.00	-26.09	Peak	



Test Mode: TX Mode (Adapter: SW-1780)

**Line**

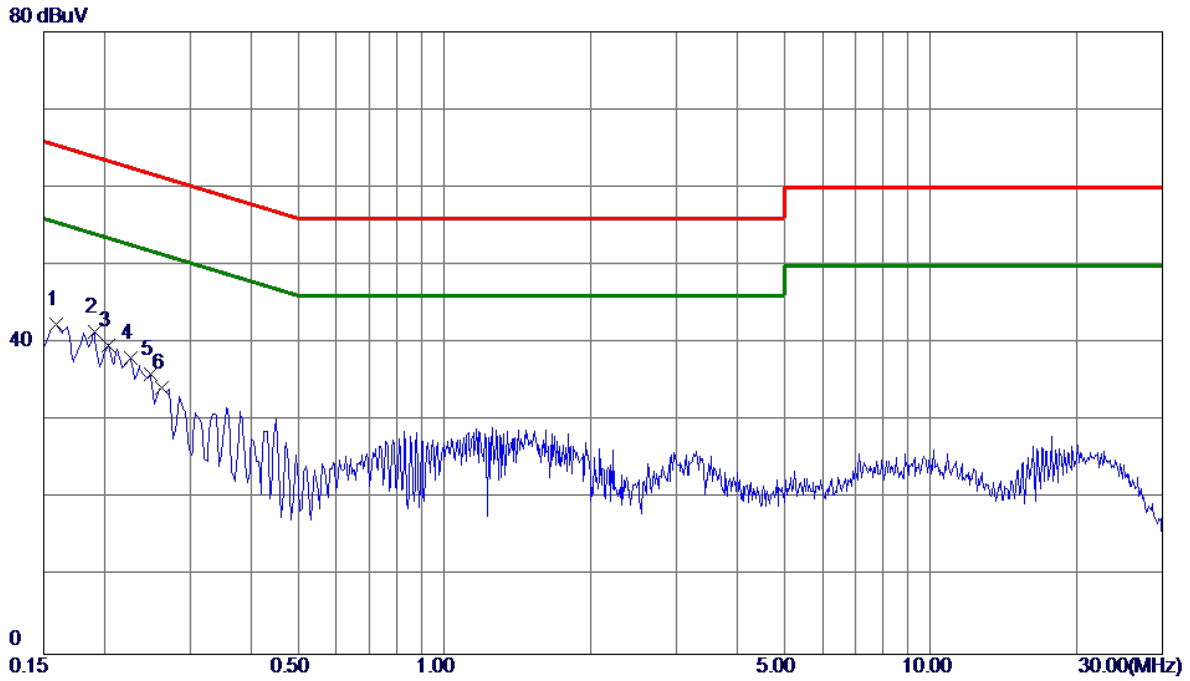

No.	Freq. MHz	Reading Level dBuV	Correct Factor dB	Measure ment dBuV	Limit dBuV	Margin dB	Detector	Comment
1	0.1590	32.63	9.82	42.45	65.52	-23.07	Peak	
2 *	0.1905	31.63	9.82	41.45	64.01	-22.56	Peak	
3	0.2040	29.94	9.82	39.76	63.45	-23.69	Peak	
4	0.2265	28.32	9.82	38.14	62.58	-24.44	Peak	
5	0.2490	26.25	9.82	36.07	61.79	-25.72	Peak	
6	0.2625	24.46	9.82	34.28	61.35	-27.07	Peak	

Test Mode: TX Mode (Adapter: SW-1780)

**Neutral**

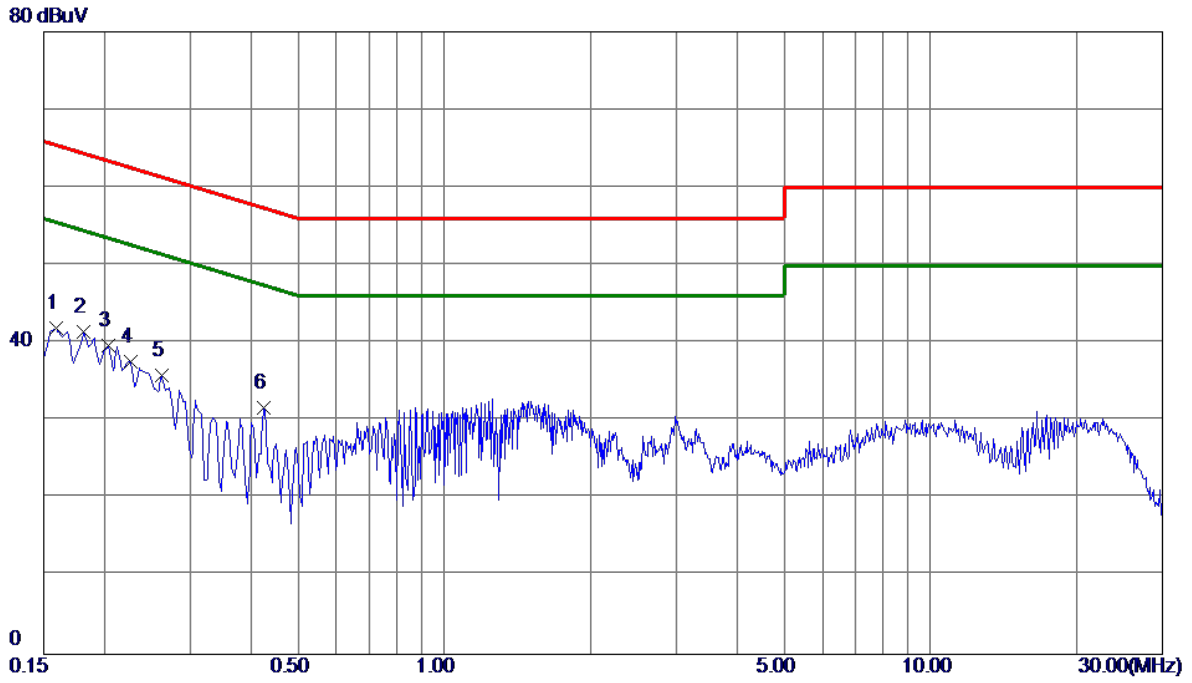

No.	Freq. MHz	Reading Level dBuV	Correct Factor dB	Measure ment dBuV	Limit dBuV	Margin dB	Detector	Comment
1	0.1590	32.05	9.91	41.96	65.52	-23.56	Peak	
2 *	0.1815	31.50	9.91	41.41	64.42	-23.01	Peak	
3	0.2040	29.76	9.91	39.67	63.45	-23.78	Peak	
4	0.2265	27.71	9.92	37.63	62.58	-24.95	Peak	
5	0.2625	25.97	9.92	35.89	61.35	-25.46	Peak	
6	0.4245	21.69	9.95	31.64	57.36	-25.72	Peak	

## APPENDIX B - RADIATED EMISSION (9 KHZ TO 30 MHZ)

Test Mode: TX Mode(Adapter: F06W-050120SPACP L.P.S)

Ant 0°

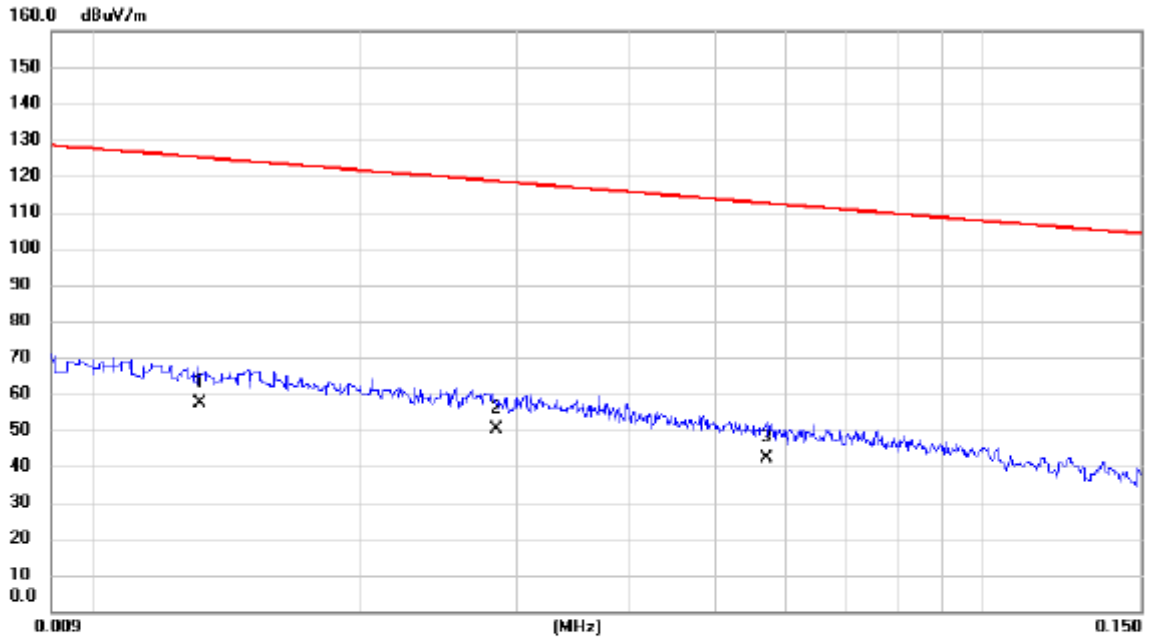

No.	Mk.	Freq. MHz	Reading Level dBuV	Correct Factor dB	Measure- ment dBuV/m	Limit dBuV/m	Margin dB	Detector	Comment
1	*	0.0132	36.30	20.97	57.27	125.19	-67.92	AVG	
2		0.0284	30.30	19.88	50.18	118.54	-68.36	AVG	
3		0.0570	22.90	19.39	42.29	112.49	-70.20	AVG	

Test Mode: TX Mode(Adapter: F06W-050120SPACP L.P.S)

Ant 0°



No.	Mk.	Freq. MHz	Reading Level dBuV	Correct Factor dB	Measure- ment dBuV/m	Limit dBuV/m	Margin dB	Detector	Comment
1		0.2562	23.90	17.06	40.96	99.43	-58.47	AVG	
2		1.1413	28.80	16.67	45.47	66.46	-20.99	QP	
3	*	2.1783	36.10	17.01	53.11	69.54	-16.43	QP	

Test Mode: TX Mode(Adapter: F06W-050120SPACP L.P.S)

Ant 90°

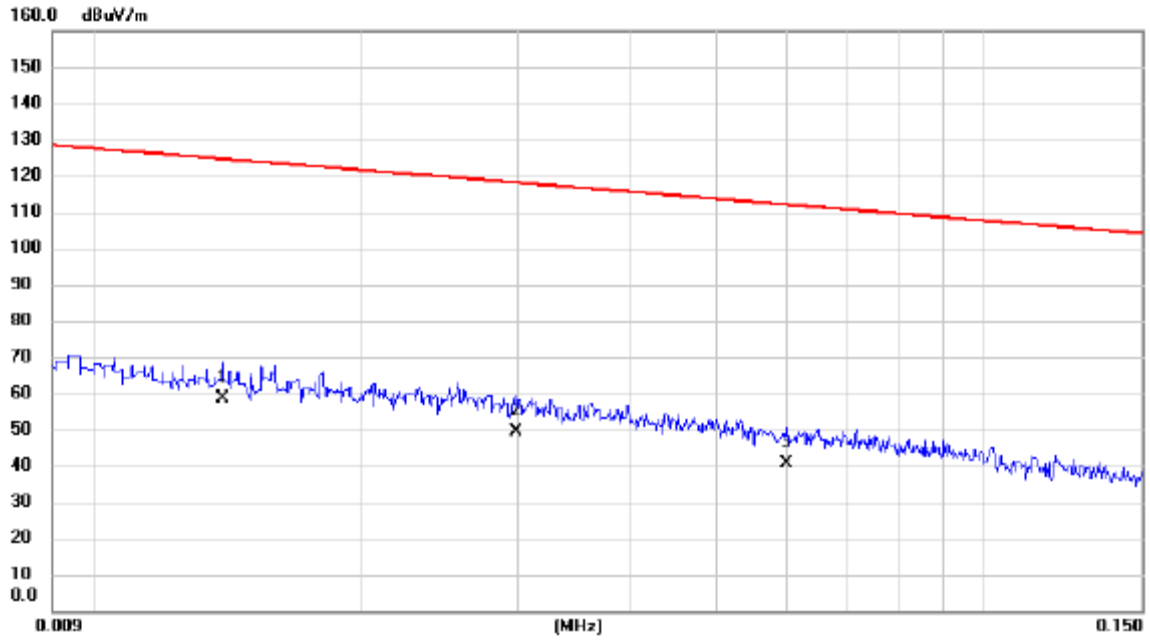

No.	Mk.	Freq. MHz	Reading Level dBuV	Correct Factor dB	Measure- ment dBuV/m	Limit dBuV/m	Margin dB	Detector	Comment
1	*	0.0140	37.60	20.86	58.46	124.68	-66.22	AVG	
2		0.0298	29.70	19.86	49.56	118.12	-68.56	AVG	
3		0.0600	21.40	19.33	40.73	112.04	-71.31	AVG	

Test Mode: TX Mode(Adapter: F06W-050120SPACP L.P.S)

Ant 90°

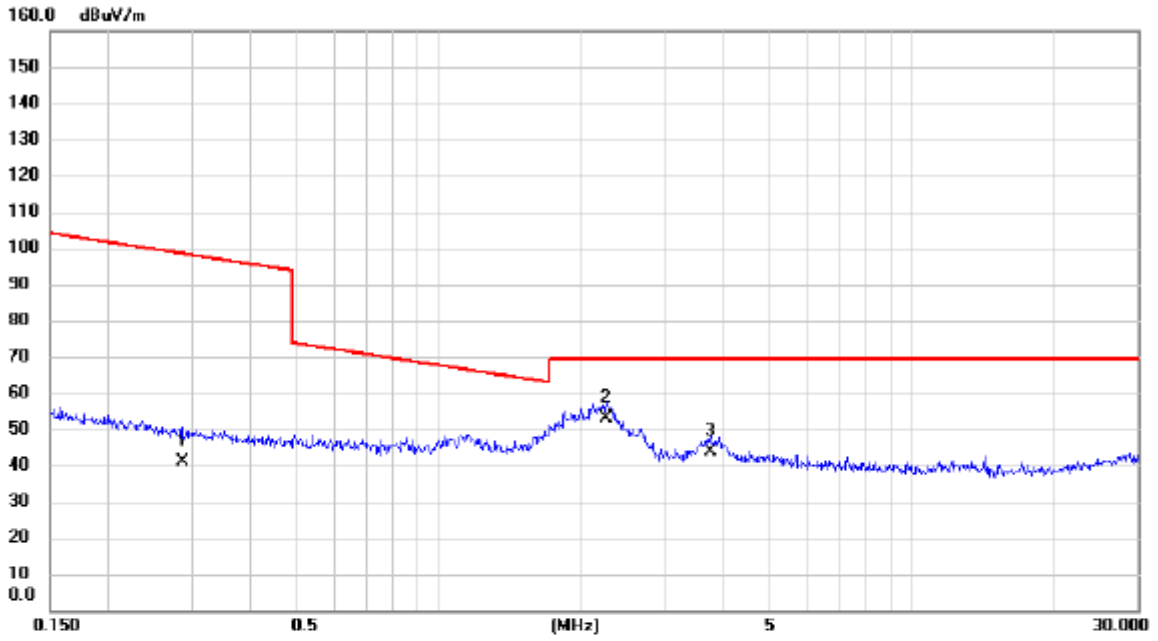

No.	Mk.	Freq. MHz	Reading Level dBuV	Correct Factor dB	Measure- ment dBuV/m	Limit dBuV/m	Margin dB	Detector	Comment
1		0.2863	23.80	17.05	40.85	98.47	-57.62	AVG	
2	*	2.2486	35.90	16.97	52.87	69.54	-16.67	QP	
3		3.7395	27.70	15.95	43.65	69.54	-25.89	QP	

Test Mode: TX Mode (Adapter: SW-1780)

Ant 0°

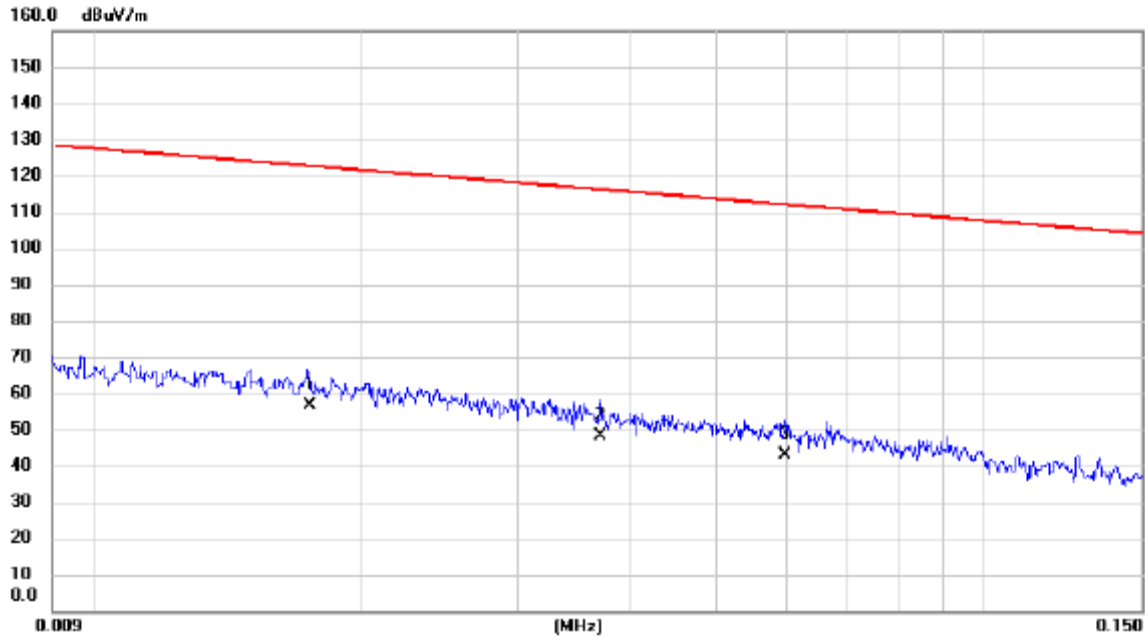

No.	Mk.	Freq. MHz	Reading Level dBuV	Correct Factor dB	Measure- ment dBuV/m	Limit dBuV/m	Margin dB	Detector	Comment
1	*	0.0175	36.20	20.37	56.57	122.74	-66.17	AVG	
2		0.0371	28.60	19.74	48.34	116.22	-67.88	AVG	
3		0.0598	23.50	19.33	42.83	112.07	-69.24	AVG	



Test Mode: TX Mode (Adapter: SW-1780)

Ant 0°



No.	Mk.	Freq.	Reading Level	Correct Factor	Measurement	Limit	Margin	Detector	Comment
		MHz	dBuV	dB	dBuV/m	dBuV/m	dB		
1		0.1796	28.10	17.20	45.30	102.52	-57.22	AVG	
2		1.0881	29.70	16.64	46.34	66.87	-20.53	QP	
3	*	1.8780	34.30	17.05	51.35	69.54	-18.19	QP	

Test Mode: TX Mode (Adapter: SW-1780)

Ant 90°

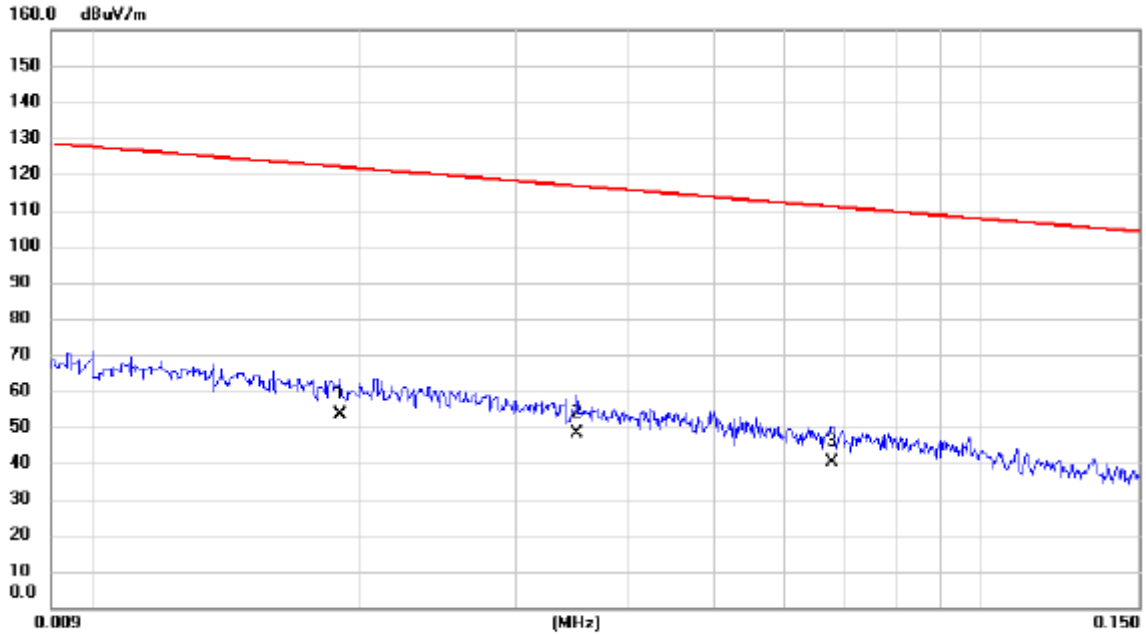

No.	Mk.	Freq. MHz	Reading Level dBuV	Correct Factor dB	Measure- ment dBuV/m	Limit dBuV/m	Margin dB	Detector	Comment
1		0.0190	33.20	20.16	53.36	122.03	-68.67	AVG	
2	*	0.0351	28.30	19.78	48.08	116.70	-68.62	AVG	
3		0.0678	20.90	19.17	40.07	110.98	-70.91	AVG	

Test Mode: TX Mode (Adapter: SW-1780)

Ant 90°

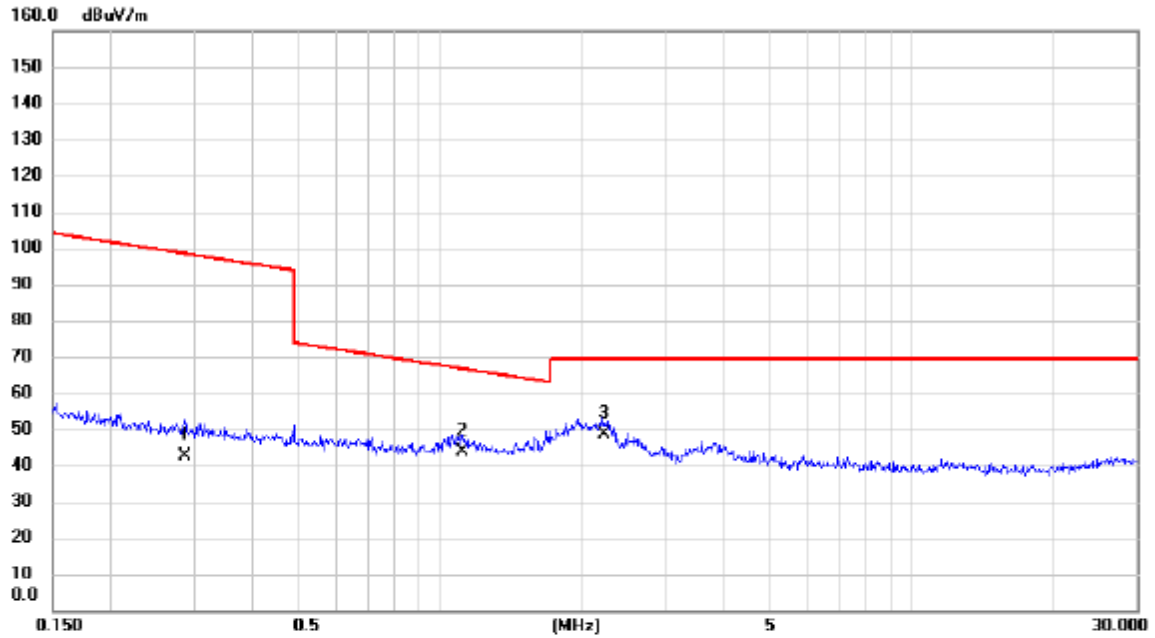

No.	Mk.	Freq. MHz	Reading Level dBuV	Correct Factor dB	Measure- ment dBuV/m	Limit dBuV/m	Margin dB	Detector	Comment
1		0.2863	25.50	17.05	42.55	98.47	-55.92	AVG	
2		1.1114	27.10	16.66	43.76	66.69	-22.93	QP	
3	*	2.2132	31.60	16.99	48.59	69.54	-20.95	QP	

## APPENDIX C - RADIATED EMISSION (30 MHZ TO 1000 MHZ)

Test Mode: TX B Mode Channel 01(Adapter: F06W-050120SPACP L.P.S)

**Vertical**

80 dBuV/m

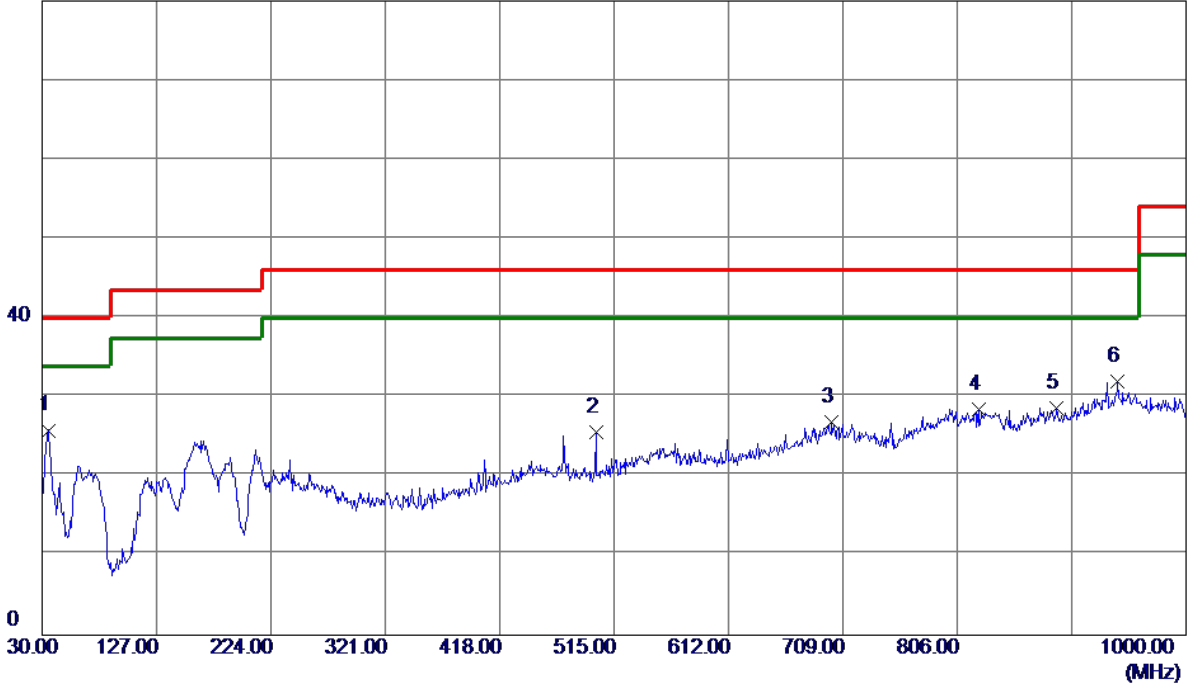

No.	Freq. MHz	Reading Level dBuV/m	Correct Factor dB	Measure ment dBuV/m	Limit dBuV/m	Margin dB	Detector	Comment
1	35.3350	40.77	-14.93	25.84	40.00	-14.16	Peak	
2	499.9650	34.11	-8.53	25.58	46.00	-20.42	Peak	
3	699.7849	29.57	-2.76	26.81	46.00	-19.19	Peak	
4	823.9450	29.95	-1.41	28.54	46.00	-17.46	Peak	
5	890.3900	29.54	-0.83	28.71	46.00	-17.29	Peak	
6 *	941.8000	30.85	1.08	31.93	46.00	-14.07	Peak	

Test Mode: TX B Mode Channel 01(Adapter: F06W-050120SPACP L.P.S)

Horizontal

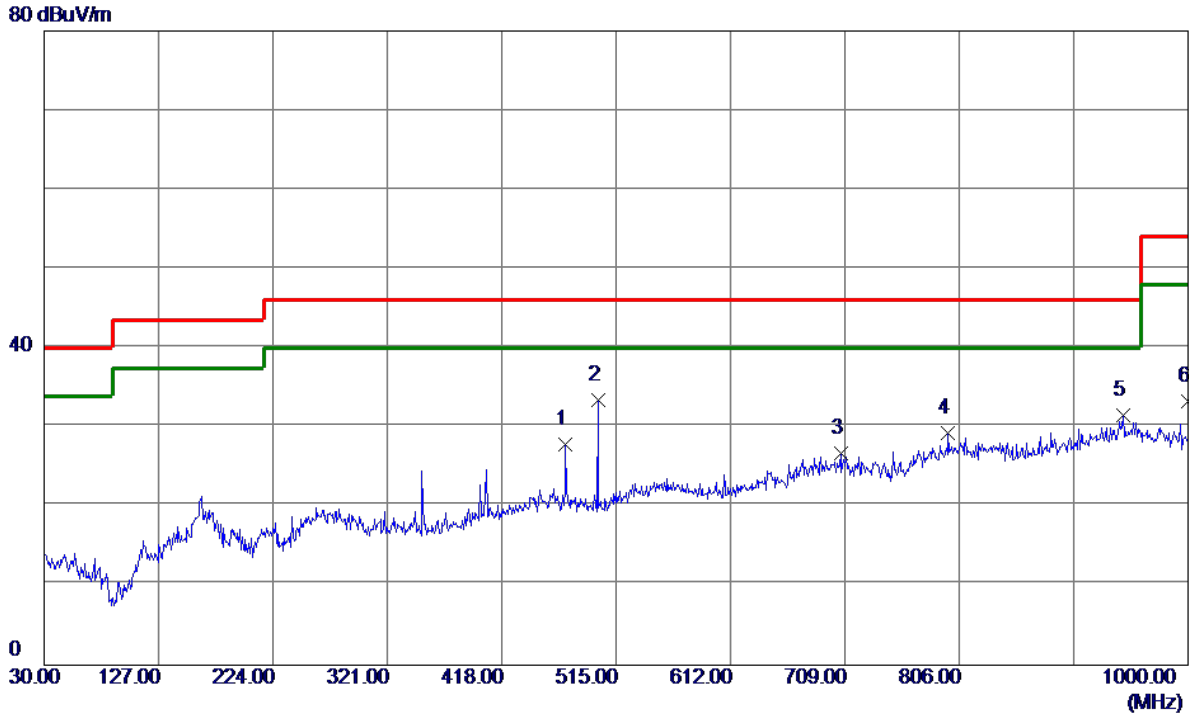

No.	Freq. MHz	Reading Level dBuV/m	Correct Factor dB	Measure ment dBuV/m	Limit dBuV/m	Margin dB	Detector	Comment
1	472.3200	35.73	-7.91	27.82	46.00	-18.18	Peak	
2 *	499.9650	41.95	-8.53	33.42	46.00	-12.58	Peak	
3	705.6050	29.68	-2.89	26.79	46.00	-19.21	Peak	
4	796.7849	30.53	-1.23	29.30	46.00	-16.70	Peak	
5	945.1950	30.29	1.22	31.51	46.00	-14.49	Peak	
6	1000.0000	33.11	0.22	33.33	54.00	-20.67	Peak	

Test Mode: TX B Mode Channel 06(Adapter: F06W-050120SPACP L.P.S)

**Vertical**

80 dBuV/m

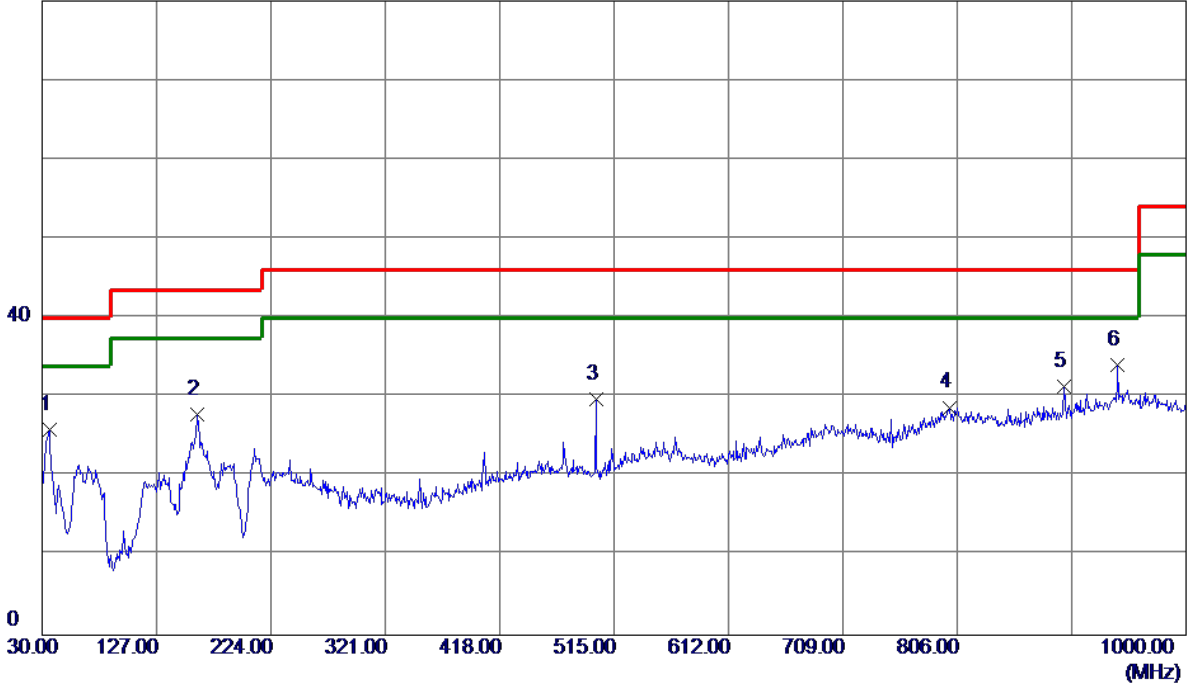

No.	Freq. MHz	Reading Level dBuV/m	Correct Factor dB	Measure ment dBuV/m	Limit dBuV/m	Margin dB	Detector	Comment
1	36.3050	40.83	-14.94	25.89	40.00	-14.11	Peak	
2	161.9200	38.56	-10.71	27.85	43.50	-15.65	Peak	
3	499.9650	38.35	-8.53	29.82	46.00	-16.18	Peak	
4	799.2100	29.81	-1.09	28.72	46.00	-17.28	Peak	
5	896.6950	32.06	-0.68	31.38	46.00	-14.62	Peak	
6 *	941.8000	33.01	1.08	34.09	46.00	-11.91	Peak	

Test Mode: TX B Mode Channel 06(Adapter: F06W-050120SPACP L.P.S)

**Horizontal**

80 dBuV/m

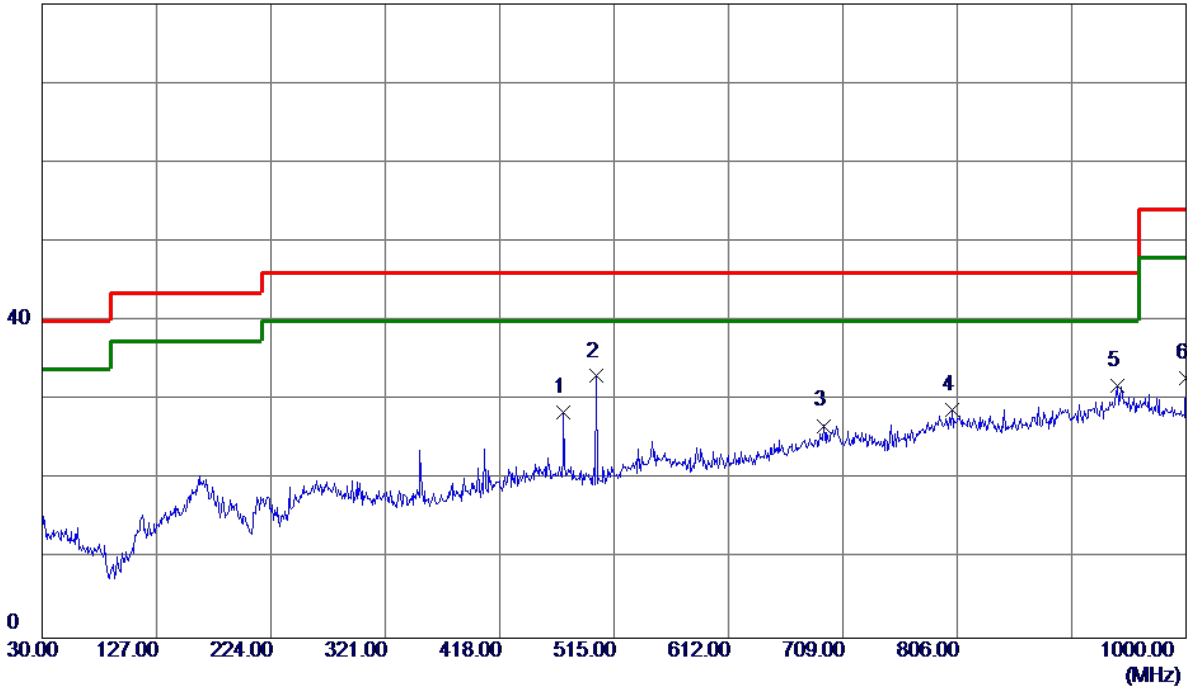

No.	Freq. MHz	Reading Level dBuV/m	Correct Factor dB	Measure ment dBuV/m	Limit dBuV/m	Margin dB	Detector	Comment
1	472.3200	36.39	-7.91	28.48	46.00	-17.52	Peak	
2 *	499.9650	41.57	-8.53	33.04	46.00	-12.96	Peak	
3	692.9950	29.89	-3.09	26.80	46.00	-19.20	Peak	
4	801.6350	29.83	-1.07	28.76	46.00	-17.24	Peak	
5	941.8000	30.79	1.08	31.87	46.00	-14.13	Peak	
6	1000.0000	32.61	0.22	32.83	54.00	-21.17	Peak	



Test Mode: TX B Mode Channel 11(Adapter: F06W-050120SPACP L.P.S)

**Vertical**

80 dBuV/m

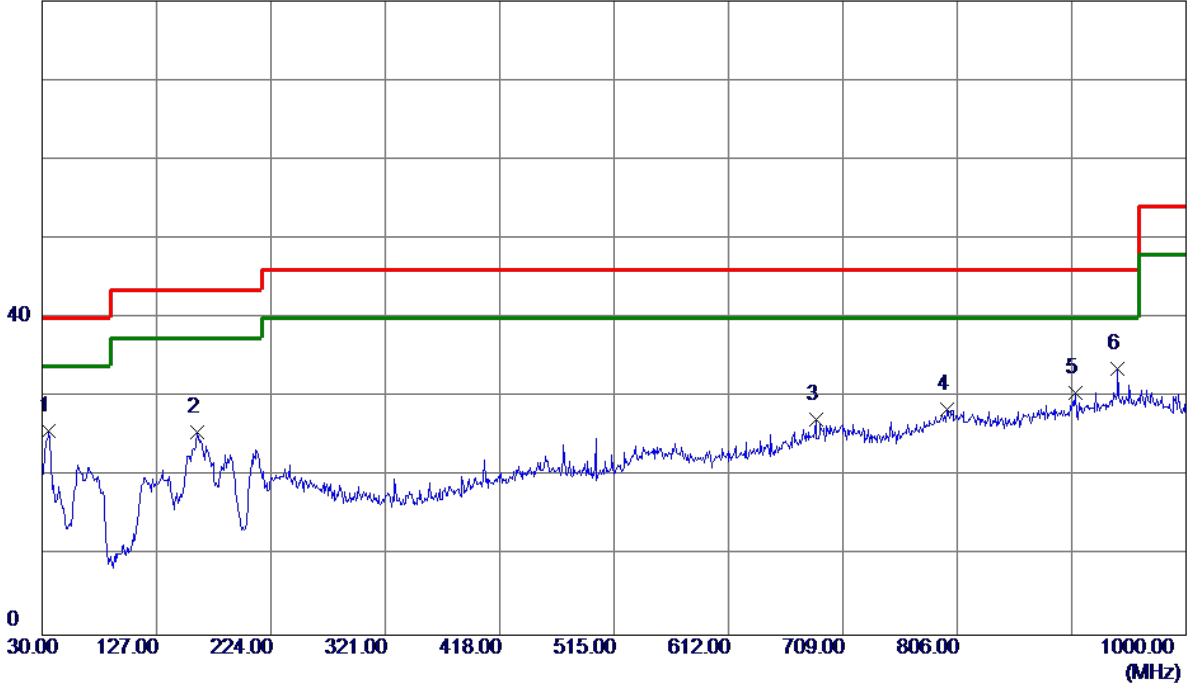

No.	Freq. MHz	Reading Level dBuV/m	Correct Factor dB	Measure ment dBuV/m	Limit dBuV/m	Margin dB	Detector	Comment
1	35.8200	40.68	-14.97	25.71	40.00	-14.29	Peak	
2	161.9200	36.24	-10.71	25.53	43.50	-17.97	Peak	
3	686.2050	30.60	-3.41	27.19	46.00	-18.81	Peak	
4	797.2700	29.67	-1.20	28.47	46.00	-17.53	Peak	
5	905.9100	30.85	-0.36	30.49	46.00	-15.51	Peak	
6 *	941.8000	32.53	1.08	33.61	46.00	-12.39	Peak	

Test Mode: TX B Mode Channel 11(Adapter: F06W-050120SPACP L.P.S)

**Horizontal**

80 dBuV/m

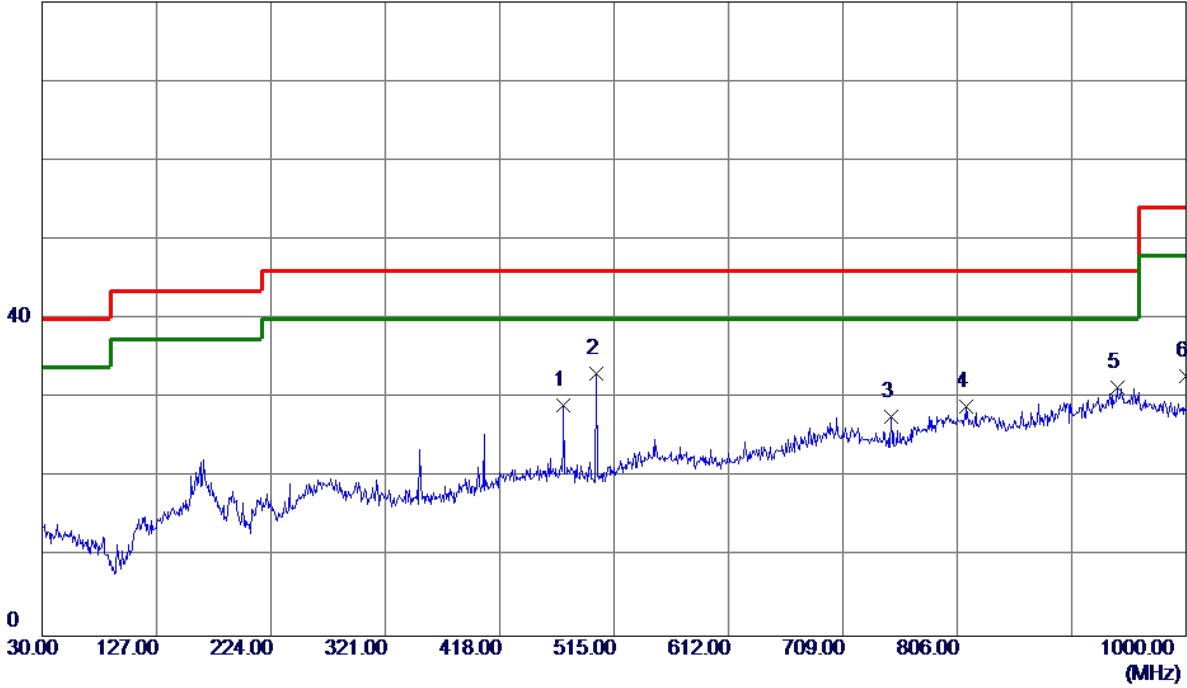

No.	Freq. MHz	Reading Level dBuV/m	Correct Factor dB	Measure ment dBuV/m	Limit dBuV/m	Margin dB	Detector	Comment
1	472.3200	36.97	-7.91	29.06	46.00	-16.94	Peak	
2 *	499.9650	41.70	-8.53	33.17	46.00	-12.83	Peak	
3	749.7400	31.75	-4.04	27.71	46.00	-18.29	Peak	
4	813.7600	30.18	-1.25	28.93	46.00	-17.07	Peak	
5	941.3150	30.25	1.06	31.31	46.00	-14.69	Peak	
6	1000.0000	32.65	0.22	32.87	54.00	-21.13	Peak	

Test Mode: TX B Mode Channel 01 (Adapter: SW-1780)

**Vertical**

80 dBuV/m

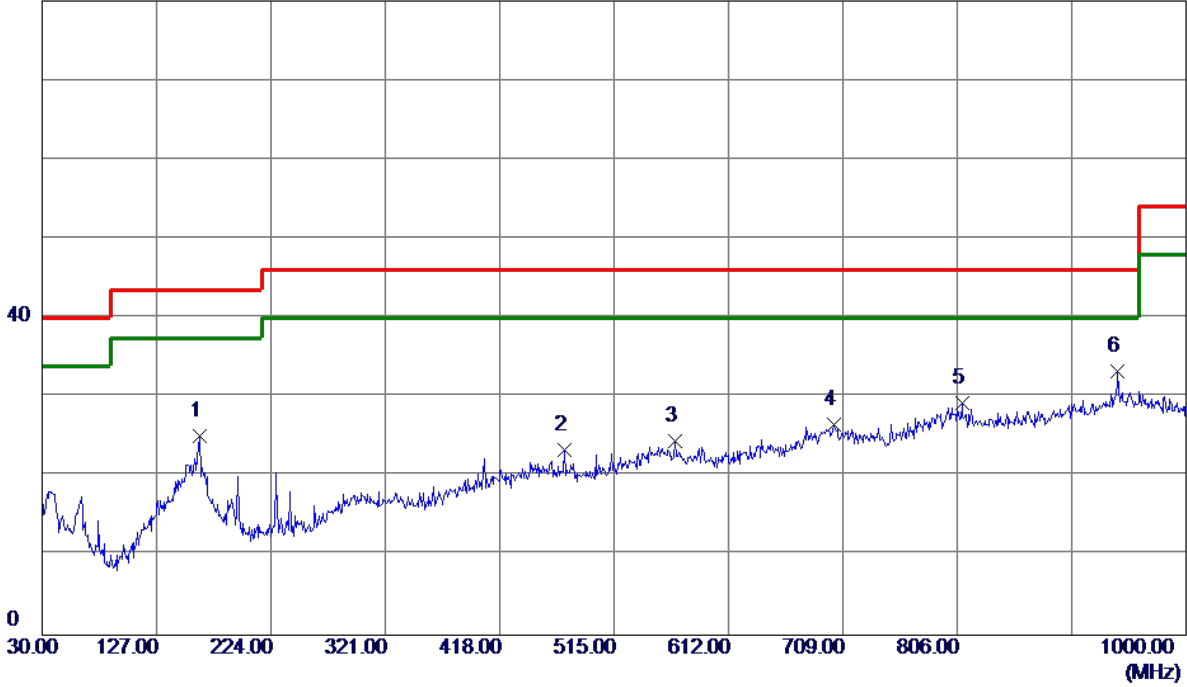

No.	Freq. MHz	Reading Level dBuV/m	Correct Factor dB	Measure ment dBuV/m	Limit dBuV/m	Margin dB	Detector	Comment
1	163.3750	35.93	-10.80	25.13	43.50	-18.37	Peak	
2	472.8050	31.35	-7.92	23.43	46.00	-22.57	Peak	
3	566.8950	30.22	-5.75	24.47	46.00	-21.53	Peak	
4	701.7250	29.33	-2.79	26.54	46.00	-19.46	Peak	
5	809.8800	30.47	-1.19	29.28	46.00	-16.72	Peak	
6 *	941.8000	32.27	1.08	33.35	46.00	-12.65	Peak	

Test Mode: TX B Mode Channel 01 (Adapter: SW-1780)

**Horizontal**

80 dBuV/m

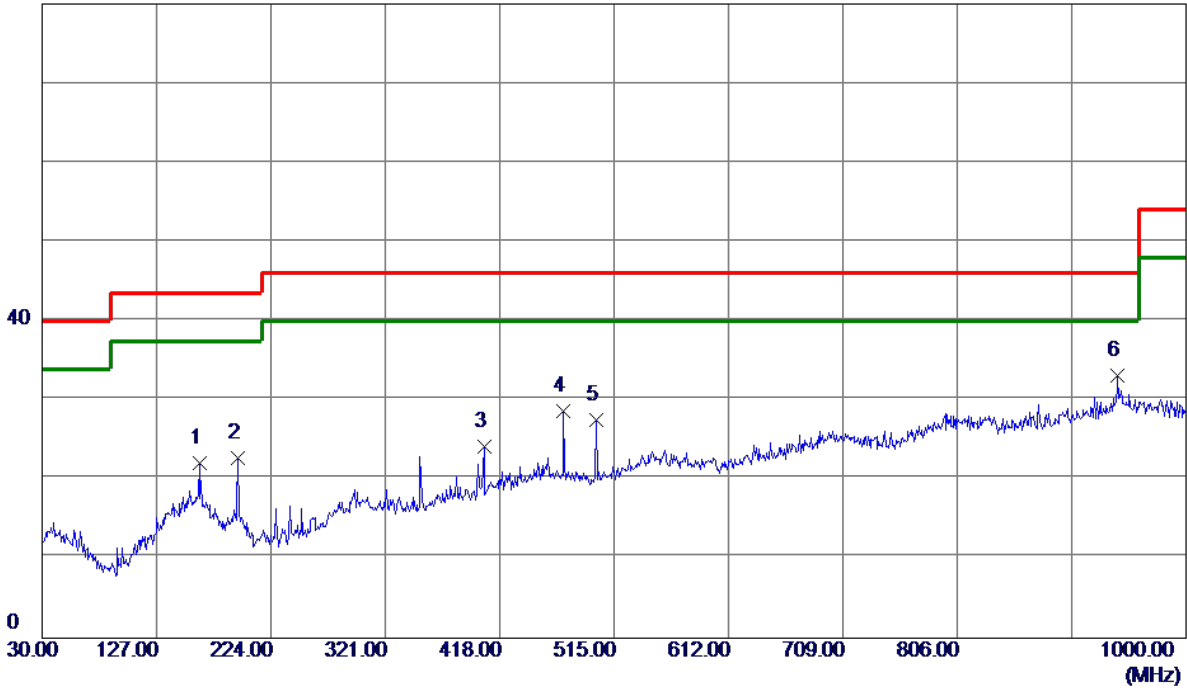

No.	Freq. MHz	Reading Level dBuV/m	Correct Factor dB	Measure ment dBuV/m	Limit dBuV/m	Margin dB	Detector	Comment
1	163.3750	32.82	-10.80	22.02	43.50	-21.48	Peak	
2	195.8700	37.50	-14.84	22.66	43.50	-20.84	Peak	
3	404.9050	33.42	-9.19	24.23	46.00	-21.77	Peak	
4	472.3200	36.50	-7.91	28.59	46.00	-17.41	Peak	
5	499.9650	36.11	-8.53	27.58	46.00	-18.42	Peak	
6 *	941.8000	32.08	1.08	33.16	46.00	-12.84	Peak	

Test Mode: TX B Mode Channel 06 (Adapter: SW-1780)

**Vertical**

80 dBuV/m

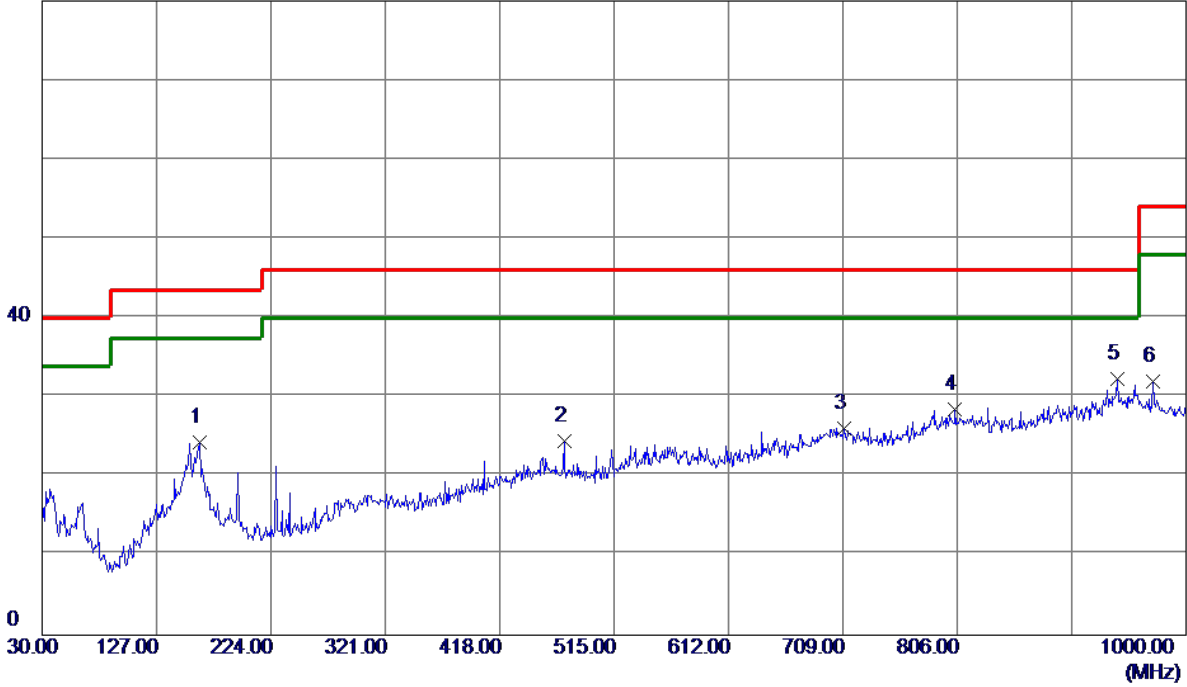

No.	Freq. MHz	Reading Level dBuV/m	Correct Factor dB	Measure ment dBuV/m	Limit dBuV/m	Margin dB	Detector	Comment
1	163.3750	35.16	-10.80	24.36	43.50	-19.14	Peak	
2	472.8050	32.37	-7.92	24.45	46.00	-21.55	Peak	
3	709.9699	29.12	-3.00	26.12	46.00	-19.88	Peak	
4	804.0600	29.51	-1.10	28.41	46.00	-17.59	Peak	
5 *	941.8000	31.25	1.08	32.33	46.00	-13.67	Peak	
6	972.3550	31.11	0.88	31.99	54.00	-22.01	Peak	

Test Mode: TX B Mode Channel 06 (Adapter: SW-1780)

### Horizontal

80 dBuV/m

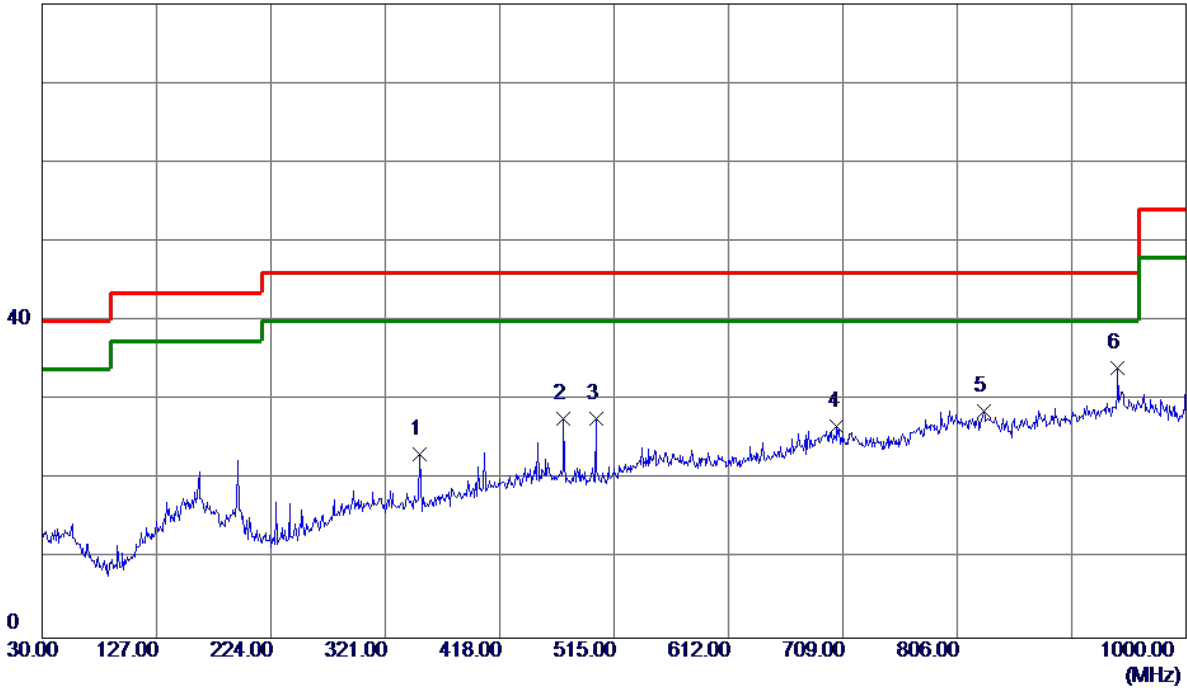

No.	Freq. MHz	Reading Level dBuV/m	Correct Factor dB	Measure ment dBuV/m	Limit dBuV/m	Margin dB	Detector	Comment
1	350.1000	34.20	-11.07	23.13	46.00	-22.87	Peak	
2	472.3200	35.61	-7.91	27.70	46.00	-18.30	Peak	
3	499.9650	36.22	-8.53	27.69	46.00	-18.31	Peak	
4	704.1500	29.60	-2.85	26.75	46.00	-19.25	Peak	
5	828.3100	30.16	-1.48	28.68	46.00	-17.32	Peak	
6 *	941.8000	32.97	1.08	34.05	46.00	-11.95	Peak	

Test Mode: TX B Mode Channel 11 (Adapter: SW-1780)

**Vertical**

80 dBuV/m

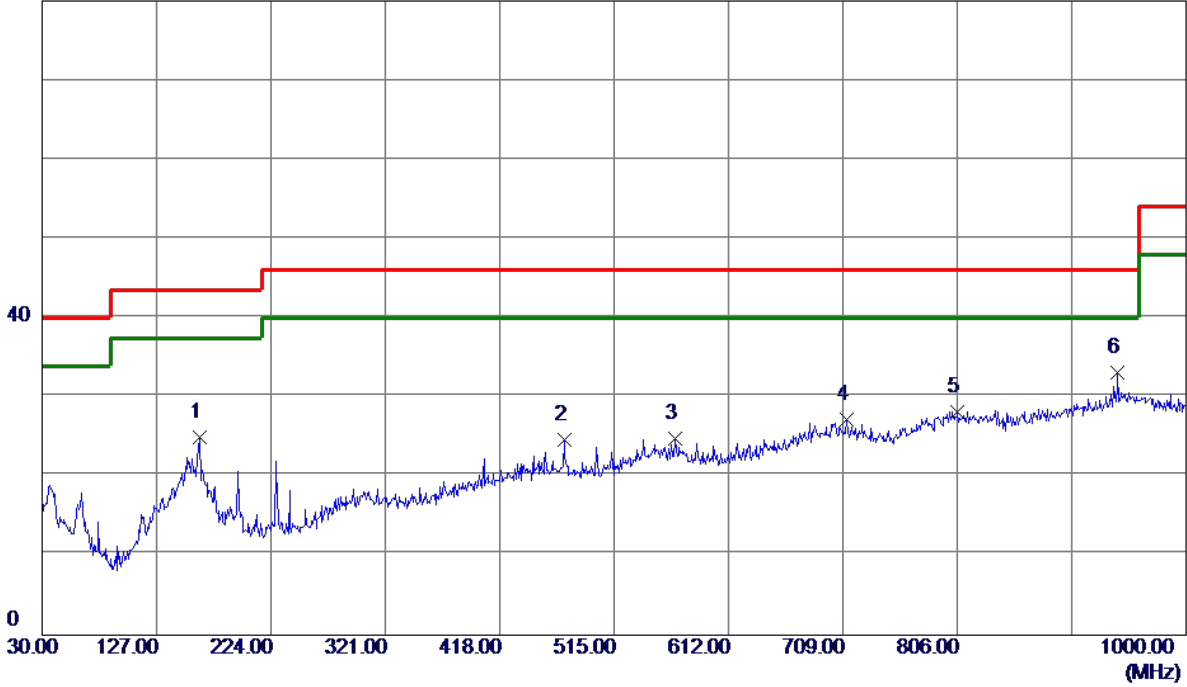

No.	Freq. MHz	Reading Level dBuV/m	Correct Factor dB	Measure ment dBuV/m	Limit dBuV/m	Margin dB	Detector	Comment
1	163.3750	35.75	-10.80	24.95	43.50	-18.55	Peak	
2	472.8050	32.49	-7.92	24.57	46.00	-21.43	Peak	
3	566.8950	30.53	-5.75	24.78	46.00	-21.22	Peak	
4	712.3950	30.20	-3.07	27.13	46.00	-18.87	Peak	
5	806.0000	29.36	-1.13	28.23	46.00	-17.77	Peak	
6 *	941.8000	32.08	1.08	33.16	46.00	-12.84	Peak	

Test Mode: TX B Mode Channel 11 (Adapter: SW-1780)

**Horizontal**

80 dBuV/m

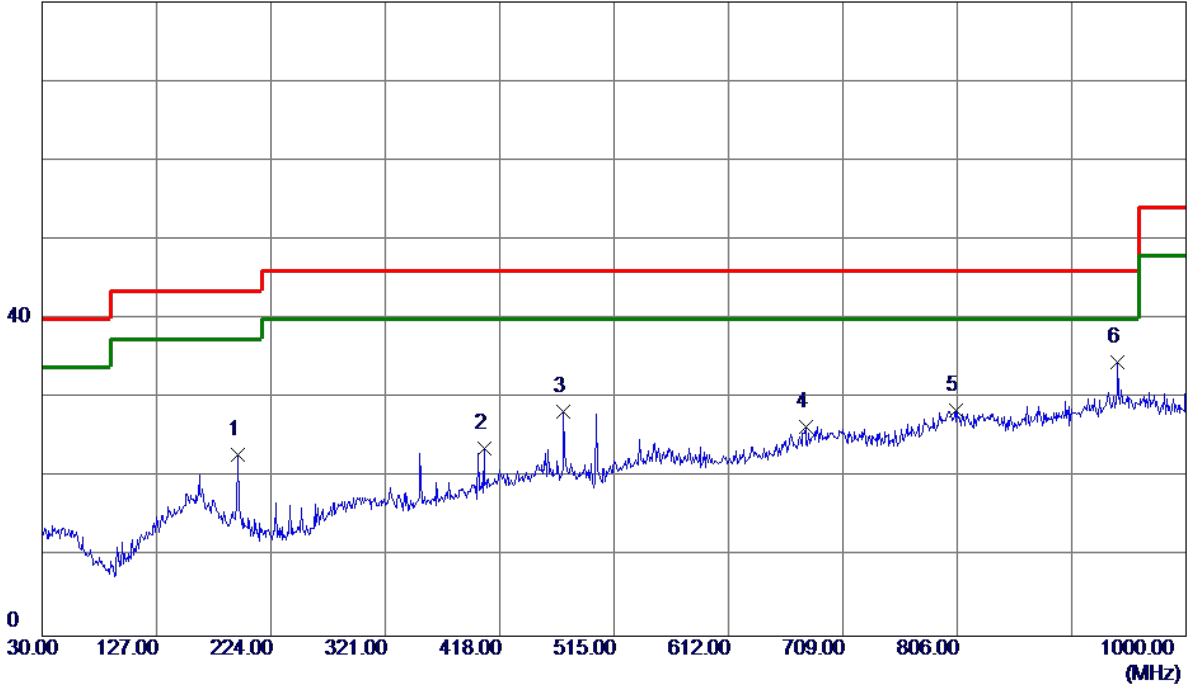

No.	Freq. MHz	Reading Level dBuV/m	Correct Factor dB	Measure ment dBuV/m	Limit dBuV/m	Margin dB	Detector	Comment
1	195.8700	37.72	-14.84	22.88	43.50	-20.62	Peak	
2	404.9050	32.82	-9.19	23.63	46.00	-22.37	Peak	
3	472.3200	36.20	-7.91	28.29	46.00	-17.71	Peak	
4	677.4750	30.23	-3.84	26.39	46.00	-19.61	Peak	
5	804.5450	29.62	-1.11	28.51	46.00	-17.49	Peak	
6 *	941.8000	33.46	1.08	34.54	46.00	-11.46	Peak	



## APPENDIX D - RADIATED EMISSION (ABOVE 1000 MHZ)

Orthogonal Axis	X
Test Mode:	TX B Mode 2412 MHz

**Vertical**

130 dBuV/m

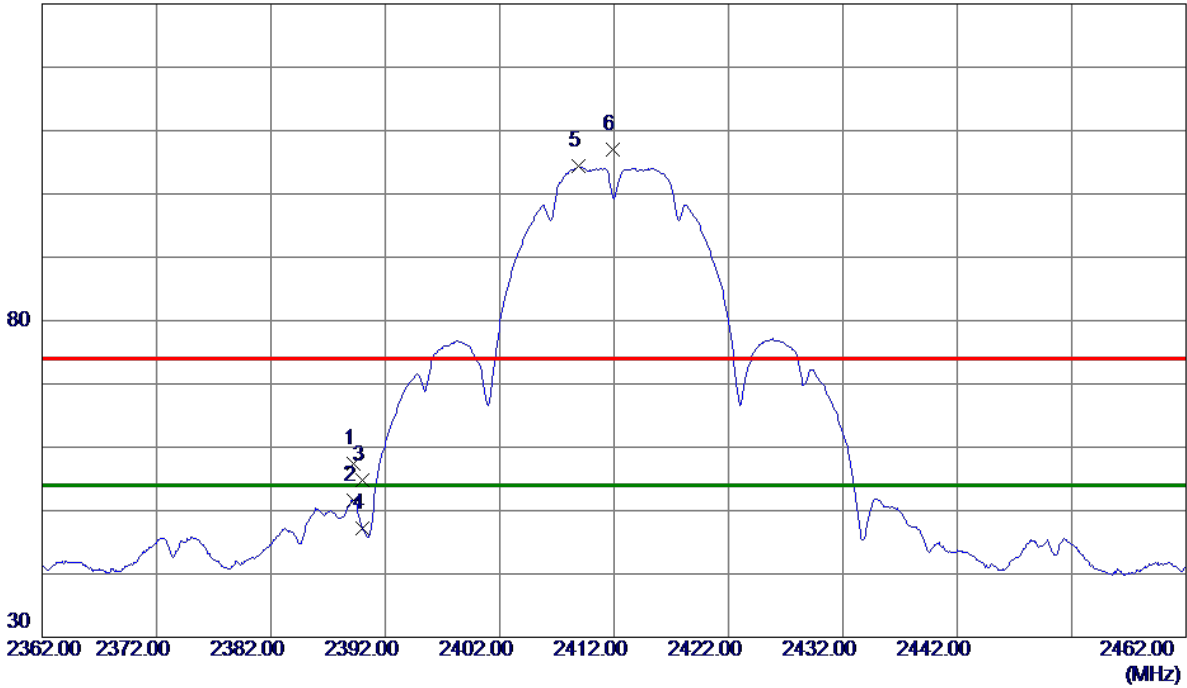

No.	Freq. MHz	Reading Level dBuV/m	Correct Factor dB	Measure ment dBuV/m	Limit dBuV/m	Margin dB	Detector	Comment
1	2389.2000	50.82	6.62	57.44	74.00	-16.56	Peak	
2	2389.2000	45.03	6.62	51.65	54.00	-2.35	AVG	
3	2390.0000	48.09	6.62	54.71	74.00	-19.29	Peak	
4	2390.0000	40.57	6.62	47.19	54.00	-6.81	AVG	
5 *	2408.9000	97.70	6.62	104.32	54.00	50.32	AVG	No Limit
6	2411.8500	100.32	6.62	106.94	74.00	32.94	Peak	No Limit

Orthogonal Axis	X
Test Mode:	TX B Mode 2412 MHz

**Vertical**

80 dBuV/m

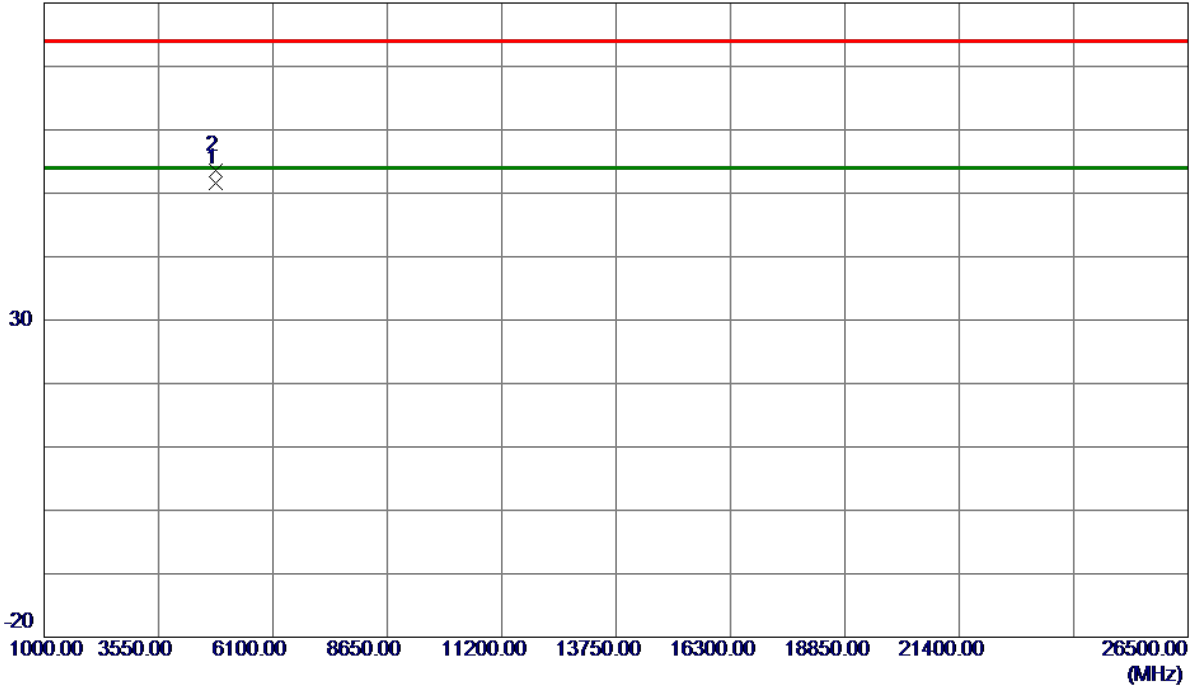

No.	Freq. MHz	Reading Level dBuV/m	Correct Factor dB	Measure ment dBuV/m	Limit dBuV/m	Margin dB	Detector	Comment
1 *	4824.0150	48.10	3.57	51.67	54.00	-2.33	AVG	
2	4824.0280	49.95	3.57	53.52	74.00	-20.48	Peak	

Orthogonal Axis	X
Test Mode:	TX B Mode 2412 MHz

**Horizontal**

130 dBuV/m

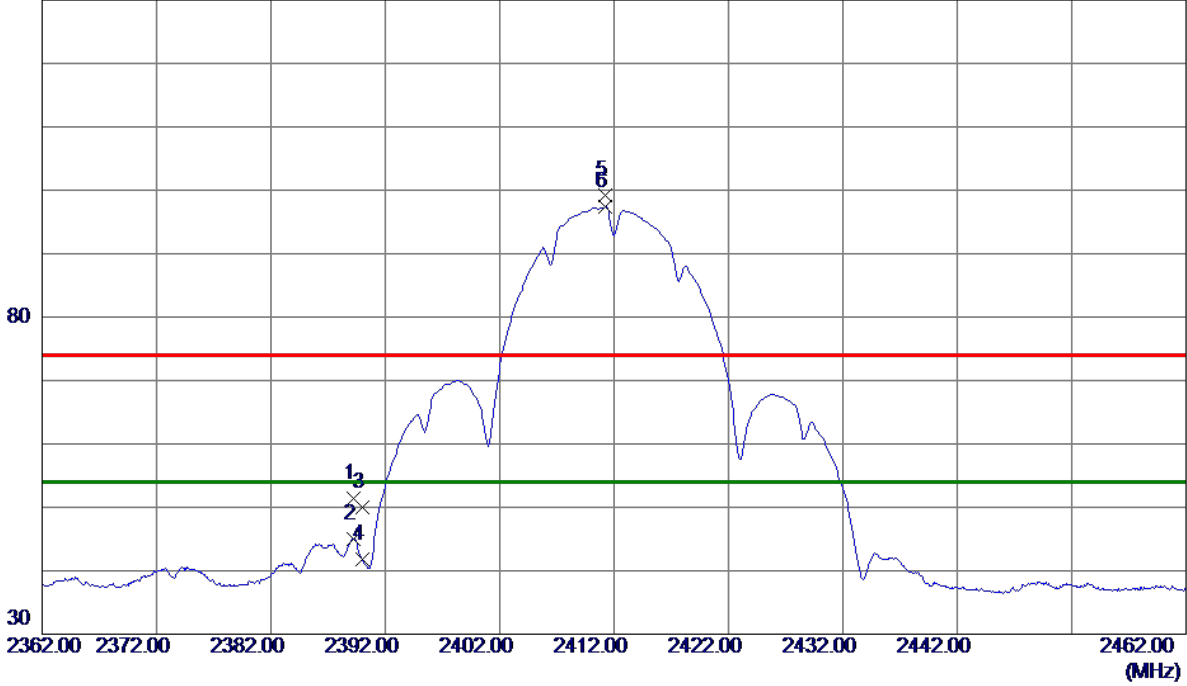

No.	Freq. MHz	Reading Level dBuV/m	Correct Factor dB	Measure ment dBuV/m	Limit dBuV/m	Margin dB	Detector	Comment
1	2389.2000	44.75	6.62	51.37	74.00	-22.63	Peak	
2	2389.2000	38.43	6.62	45.05	54.00	-8.95	AVG	
3	2390.0000	43.36	6.62	49.98	74.00	-24.02	Peak	
4	2390.0000	35.14	6.62	41.76	54.00	-12.24	AVG	
5	2411.2000	92.60	6.62	99.22	74.00	25.22	Peak	No Limit
6 *	2411.2500	90.70	6.62	97.32	54.00	43.32	AVG	No Limit

Orthogonal Axis	X
Test Mode:	TX B Mode 2412 MHz

**Horizontal**

80 dBuV/m

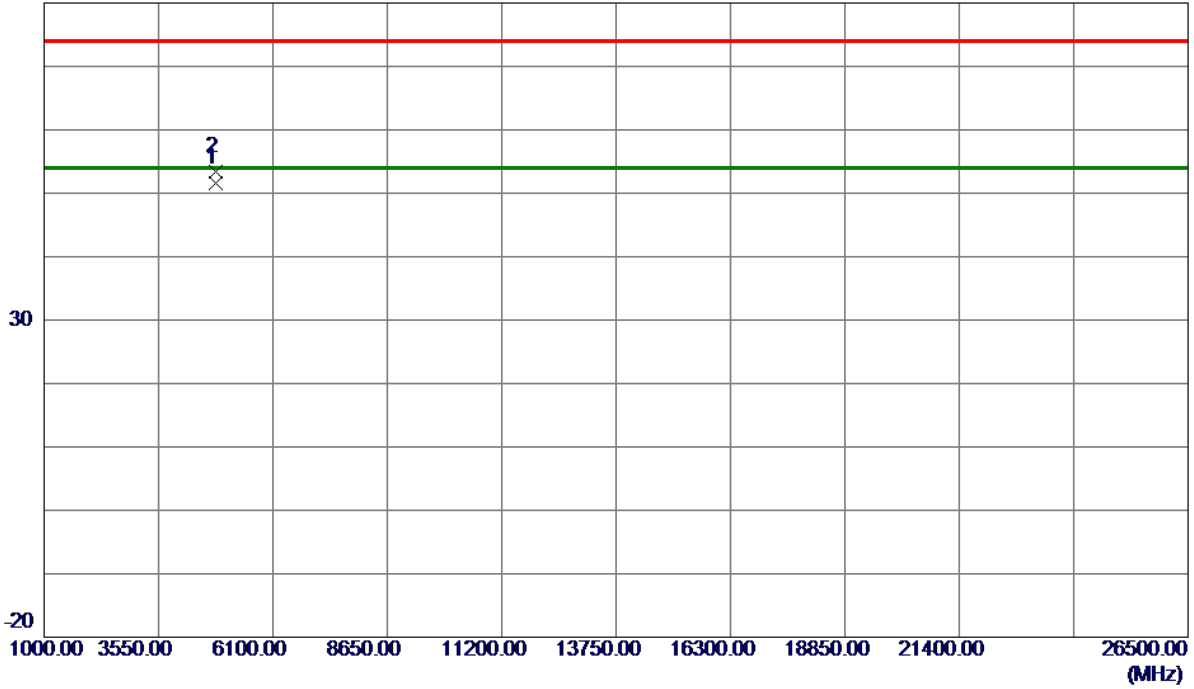

No.	Freq. MHz	Reading Level dBuV/m	Correct Factor dB	Measure ment dBuV/m	Limit dBuV/m	Margin dB	Detector	Comment
1 *	4823.9880	48.07	3.57	51.64	54.00	-2.36	AVG	
2	4824.0080	49.87	3.57	53.44	74.00	-20.56	Peak	

Orthogonal Axis	X
Test Mode:	TX B Mode 2437 MHz

**Vertical**

130 dBuV/m

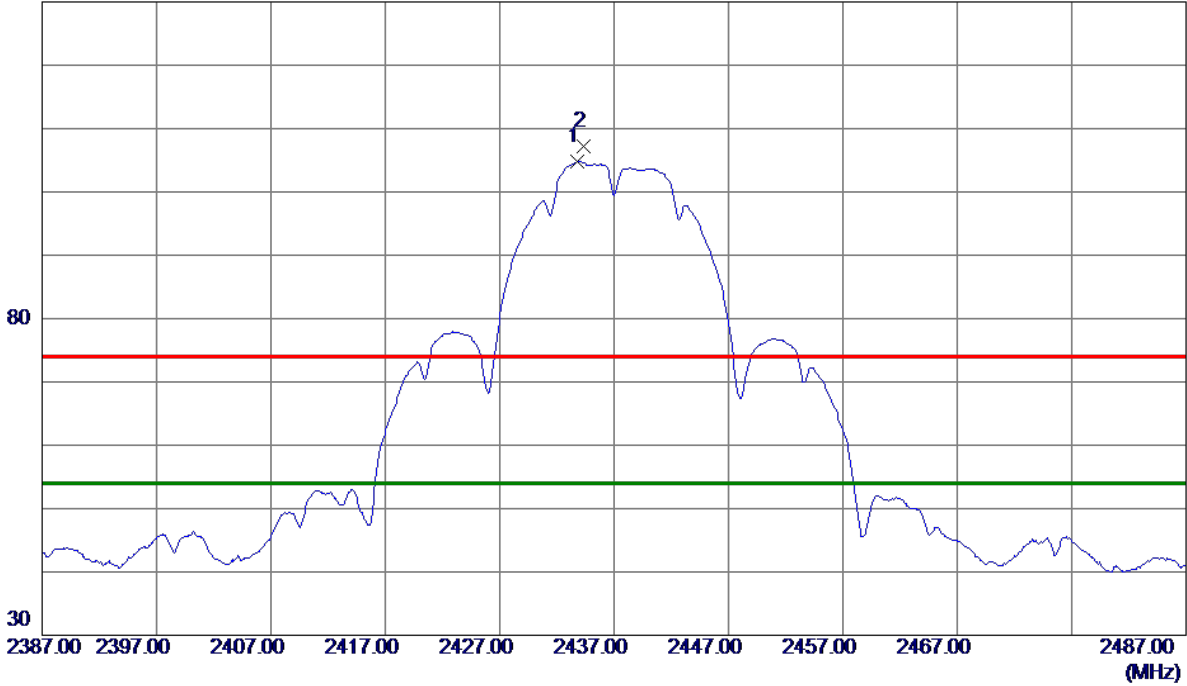

No.	Freq. MHz	Reading Level dBuV/m	Correct Factor dB	Measure ment dBuV/m	Limit dBuV/m	Margin dB	Detector	Comment
1 *	2433.8000	98.26	6.61	104.87	54.00	50.87	AVG	No Limit
2	2434.3000	100.56	6.61	107.17	74.00	33.17	Peak	No Limit

Orthogonal Axis	X
Test Mode:	TX B Mode 2437 MHz

**Vertical**

80 dBuV/m

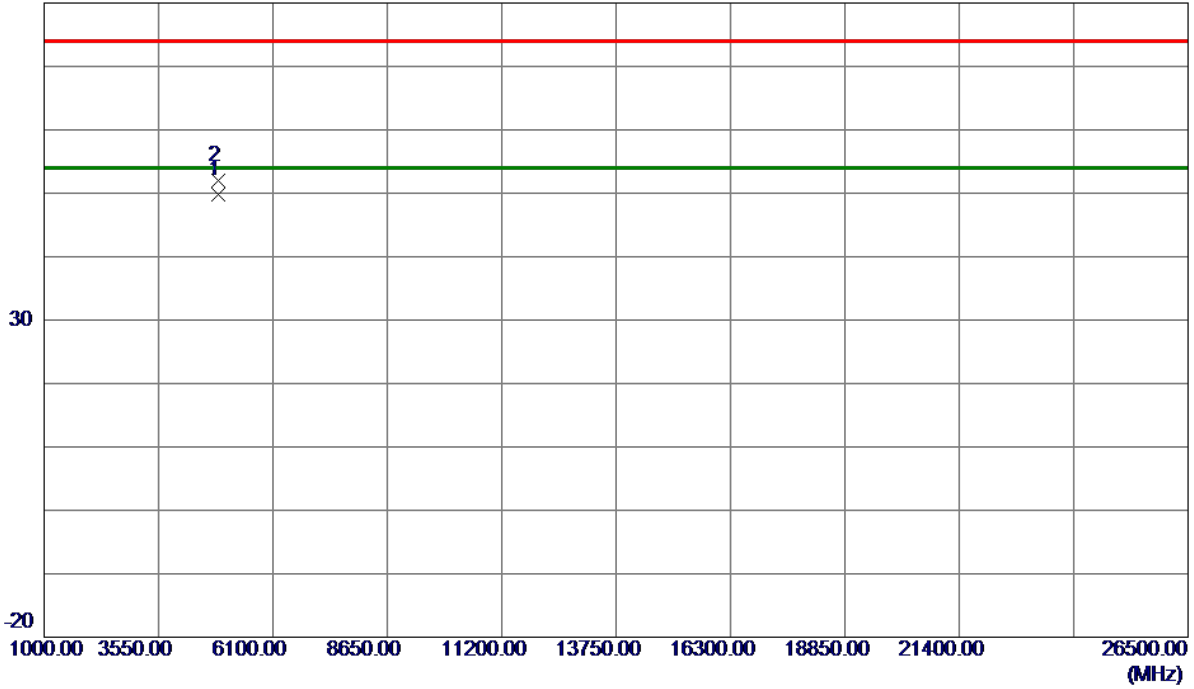

No.	Freq. MHz	Reading Level dBuV/m	Correct Factor dB	Measure ment dBuV/m	Limit dBuV/m	Margin dB	Detector	Comment
1 *	4875.6300	46.15	3.69	49.84	54.00	-4.16	AVG	
2	4876.1900	48.36	3.69	52.05	74.00	-21.95	Peak	

Orthogonal Axis	X
Test Mode:	TX B Mode 2437 MHz

### Horizontal

130 dBuV/m

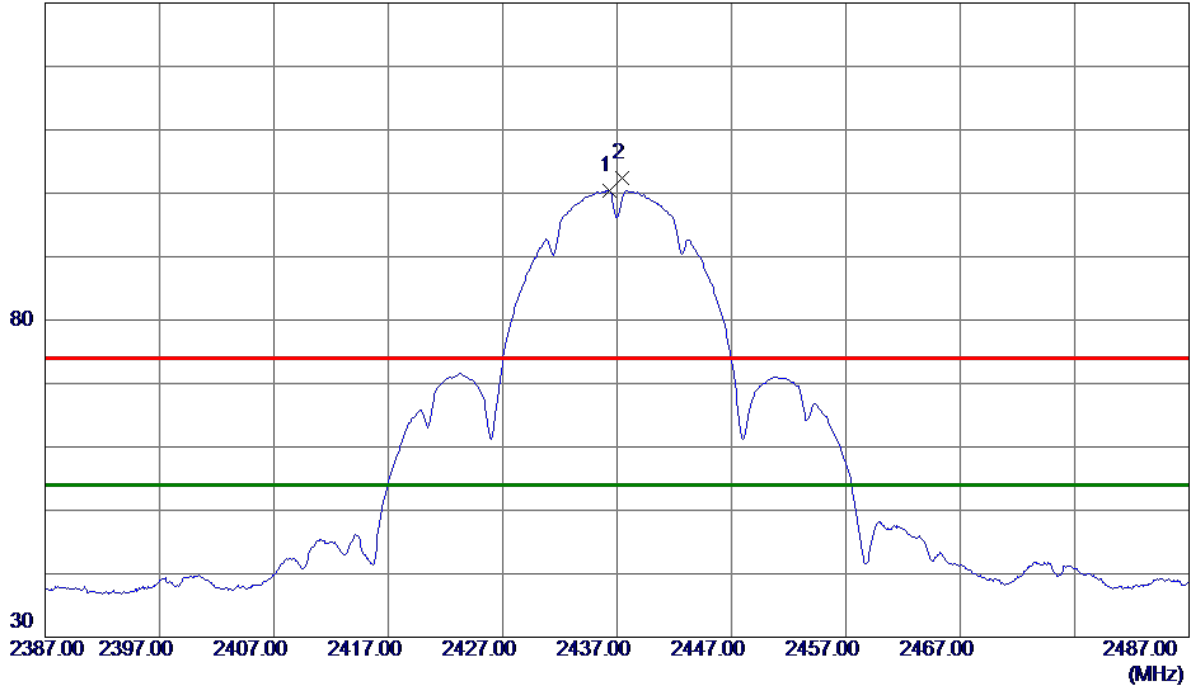

No.	Freq. MHz	Reading Level dBuV/m	Correct Factor dB	Measure ment dBuV/m	Limit dBuV/m	Margin dB	Detector	Comment
1 *	2436.3500	93.87	6.61	100.48	54.00	46.48	AVG	No Limit
2	2437.4000	95.78	6.61	102.39	74.00	28.39	Peak	No Limit



Orthogonal Axis	X
Test Mode:	TX B Mode 2437 MHz

**Horizontal**

80 dBuV/m

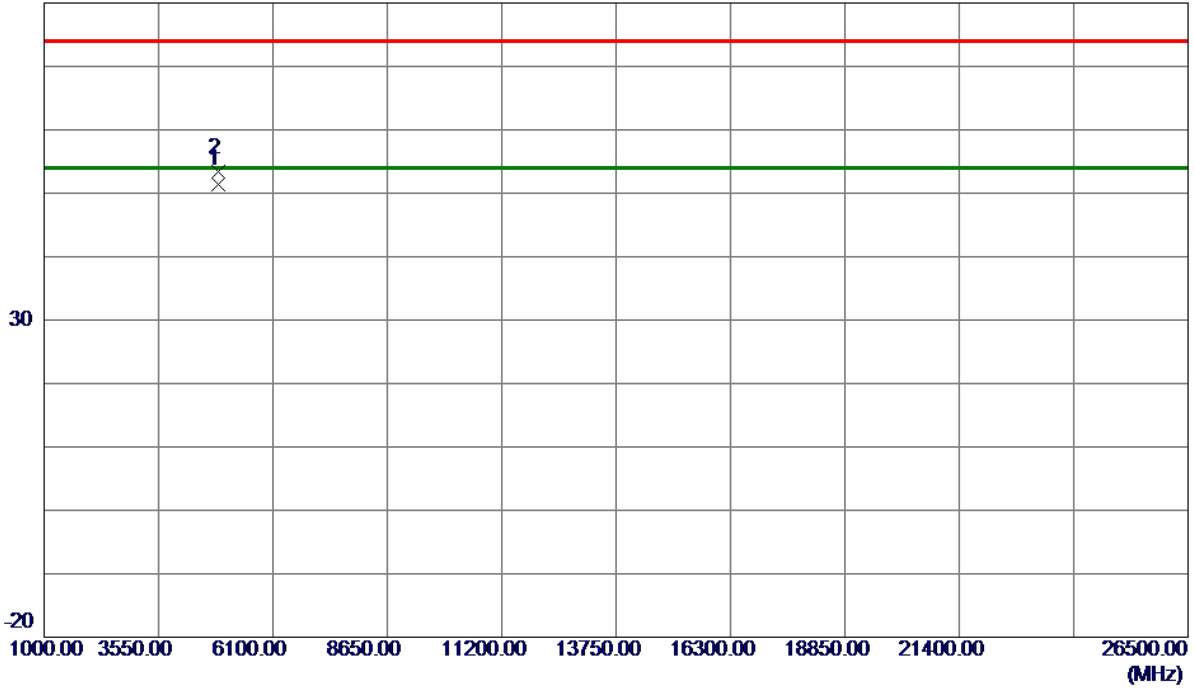

No.	Freq. MHz	Reading Level dBuV/m	Correct Factor dB	Measure ment dBuV/m	Limit dBuV/m	Margin dB	Detector	Comment
1 *	4874.0019	47.80	3.68	51.48	54.00	-2.52	AVG	
2	4874.0280	49.62	3.68	53.30	74.00	-20.70	Peak	

Orthogonal Axis	X
Test Mode:	TX B Mode 2462 MHz

**Vertical**

130 dBuV/m

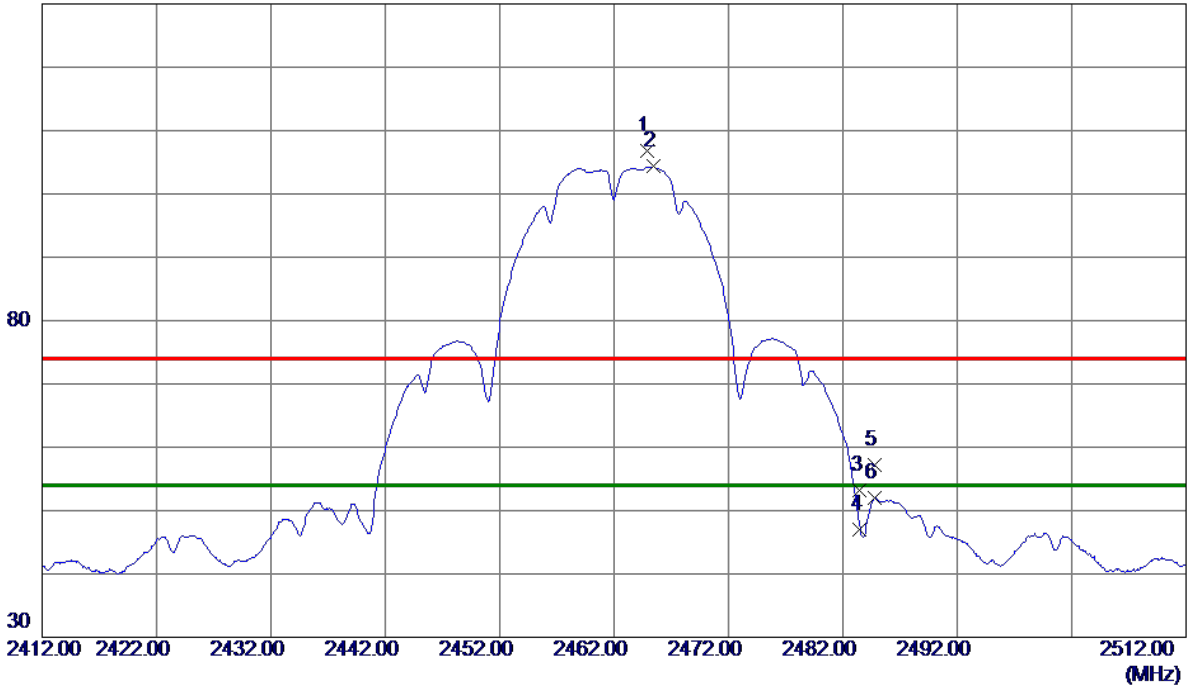

No.	Freq. MHz	Reading Level dBuV/m	Correct Factor dB	Measure ment dBuV/m	Limit dBuV/m	Margin dB	Detector	Comment
1	2464.8500	100.11	6.61	106.72	74.00	32.72	Peak	No Limit
2 *	2465.4500	97.71	6.61	104.32	54.00	50.32	AVG	No Limit
3	2483.5000	46.56	6.61	53.17	74.00	-20.83	Peak	
4	2483.5000	40.44	6.61	47.05	54.00	-6.95	AVG	
5	2484.7500	50.53	6.61	57.14	74.00	-16.86	Peak	
6	2484.7500	45.32	6.61	51.93	54.00	-2.07	AVG	

Orthogonal Axis	X
Test Mode:	TX B Mode 2462 MHz

**Vertical**

80 dBuV/m

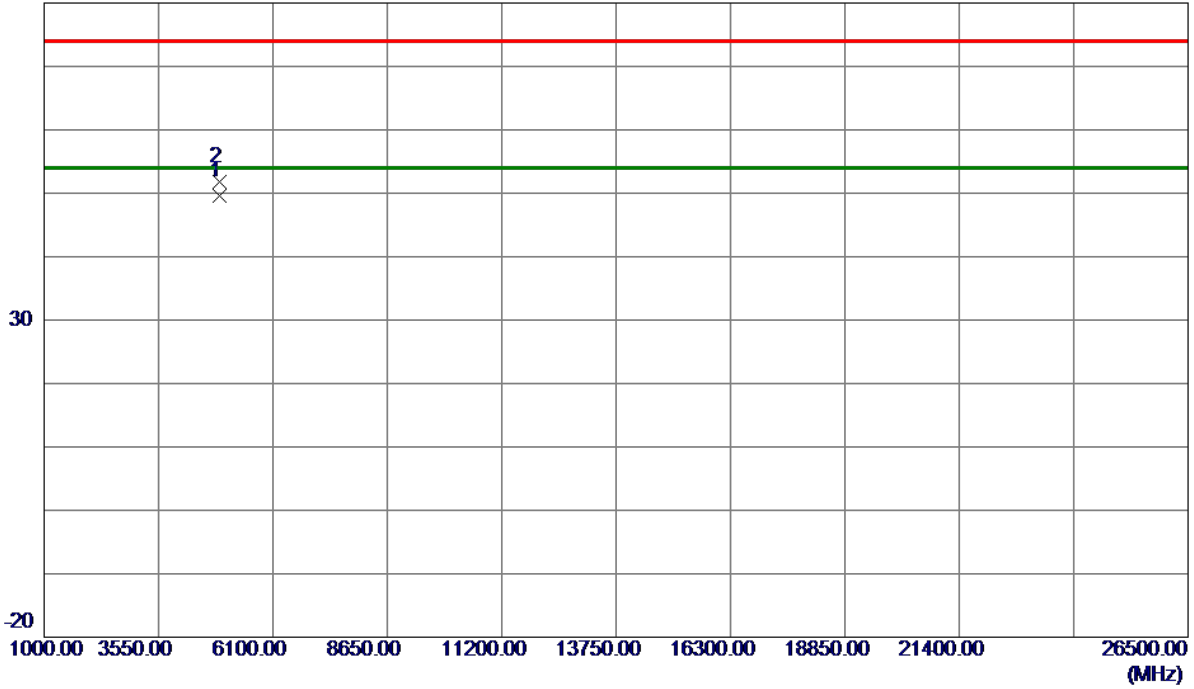

No.	Freq. MHz	Reading Level dBuV/m	Correct Factor dB	Measure ment dBuV/m	Limit dBuV/m	Margin dB	Detector	Comment
1 *	4924.0099	45.77	3.79	49.56	54.00	-4.44	AVG	
2	4924.1150	48.05	3.79	51.84	74.00	-22.16	Peak	

Orthogonal Axis	X
Test Mode:	TX B Mode 2462 MHz

### Horizontal

130 dBuV/m

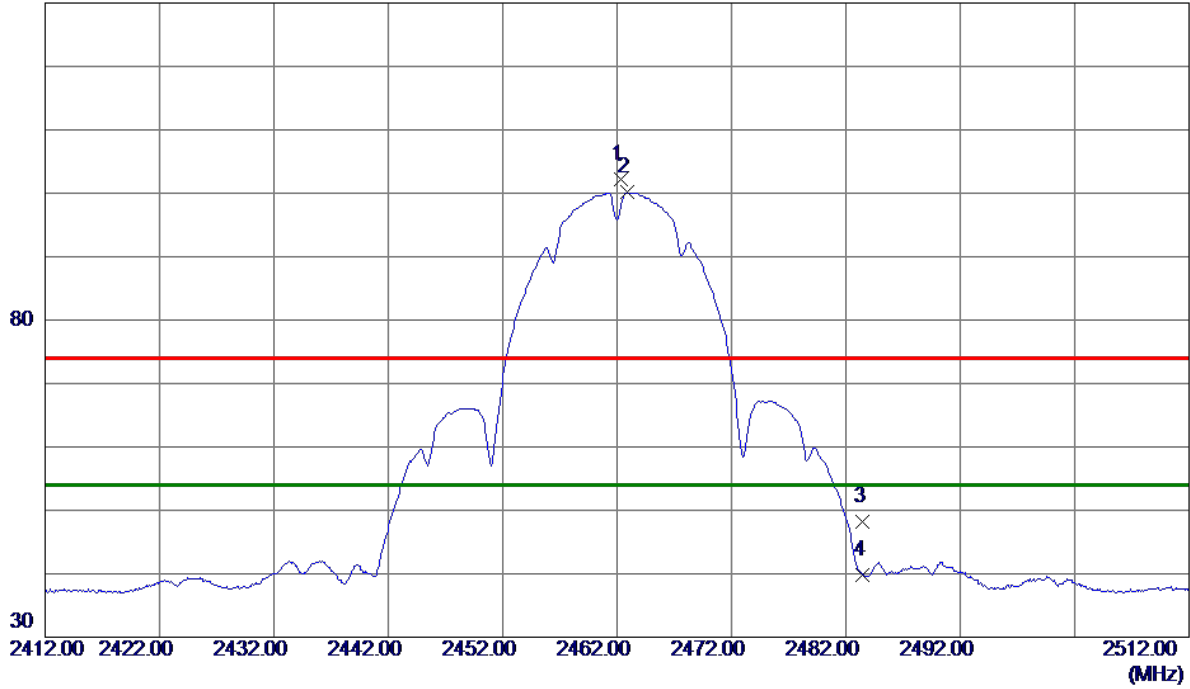

No.	Freq. MHz	Reading Level dBuV/m	Correct Factor dB	Measure ment dBuV/m	Limit dBuV/m	Margin dB	Detector	Comment
1	2462.3000	95.50	6.61	102.11	74.00	28.11	Peak	No Limit
2 *	2462.8500	93.59	6.61	100.20	54.00	46.20	AVG	No Limit
3	2483.5000	41.59	6.61	48.20	74.00	-25.80	Peak	
4	2483.5000	33.23	6.61	39.84	54.00	-14.16	AVG	

Orthogonal Axis	X
Test Mode:	TX B Mode 2462 MHz

**Horizontal**

80 dBuV/m

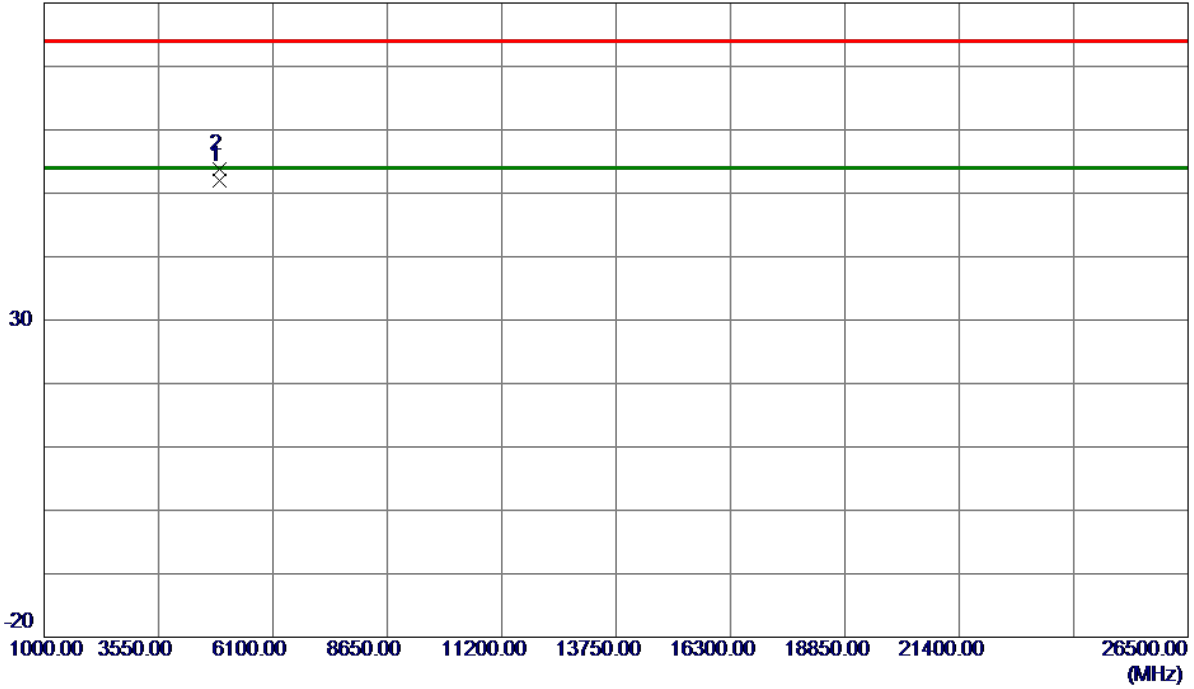

No.	Freq. MHz	Reading Level dBuV/m	Correct Factor dB	Measure ment dBuV/m	Limit dBuV/m	Margin dB	Detector	Comment
1 *	4924.0110	48.15	3.79	51.94	54.00	-2.06	AVG	
2	4924.0820	50.02	3.79	53.81	74.00	-20.19	Peak	

Orthogonal Axis	X
Test Mode:	TX G Mode 2412 MHz

**Vertical**

130 dBuV/m

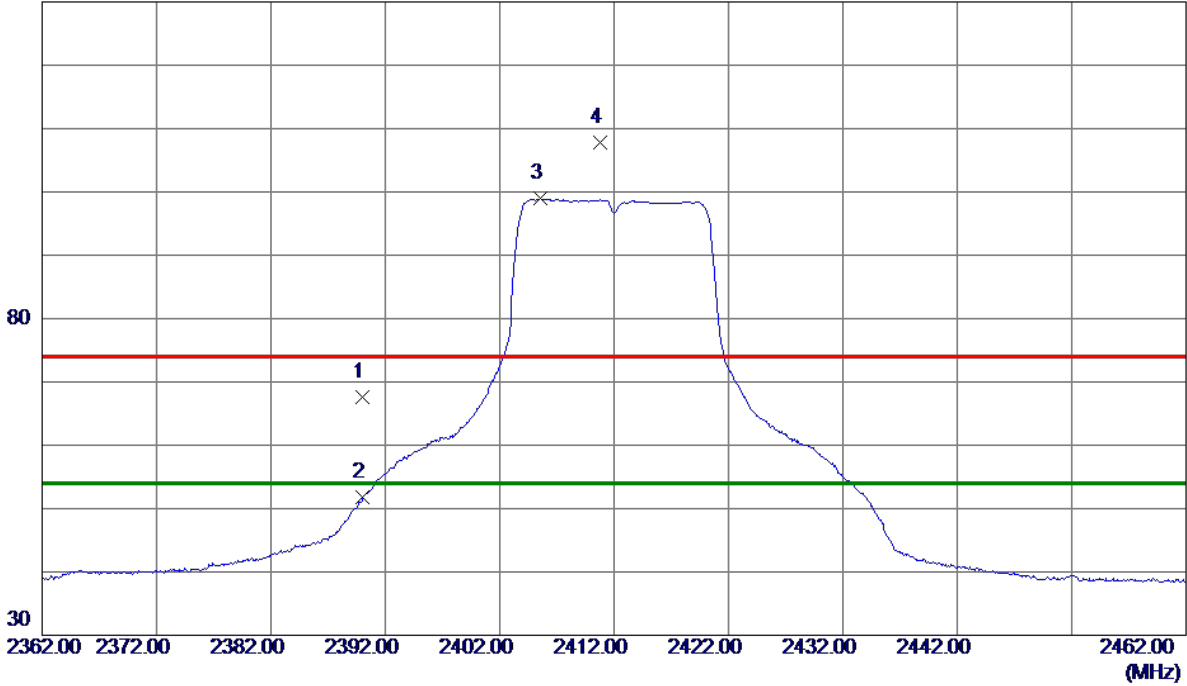

No.	Freq. MHz	Reading Level dBuV/m	Correct Factor dB	Measure ment dBuV/m	Limit dBuV/m	Margin dB	Detector	Comment
1	2390.0000	61.02	6.62	67.64	74.00	-6.36	Peak	
2	2390.0000	45.14	6.62	51.76	54.00	-2.24	AVG	
3 *	2405.6000	92.30	6.62	98.92	54.00	44.92	AVG	No Limit
4	2410.8000	101.09	6.62	107.71	74.00	33.71	Peak	No Limit

Orthogonal Axis	X
Test Mode:	TX G Mode 2412 MHz

**Vertical**

80 dBuV/m

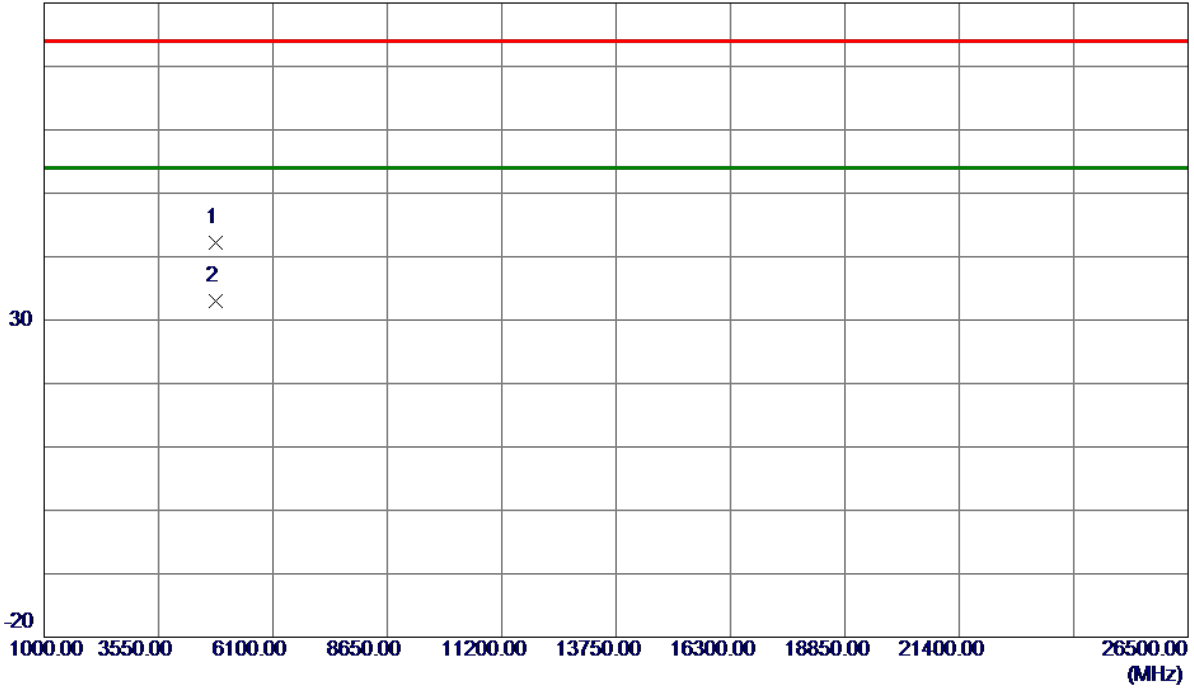

No.	Freq. MHz	Reading Level dBuV/m	Correct Factor dB	Measure ment dBuV/m	Limit dBuV/m	Margin dB	Detector	Comment
1	4812.0500	38.74	3.54	42.28	74.00	-31.72	Peak	
2 *	4824.0250	29.44	3.57	33.01	54.00	-20.99	AVG	

Orthogonal Axis	X
Test Mode:	TX G Mode 2412 MHz

### Horizontal

130 dBuV/m

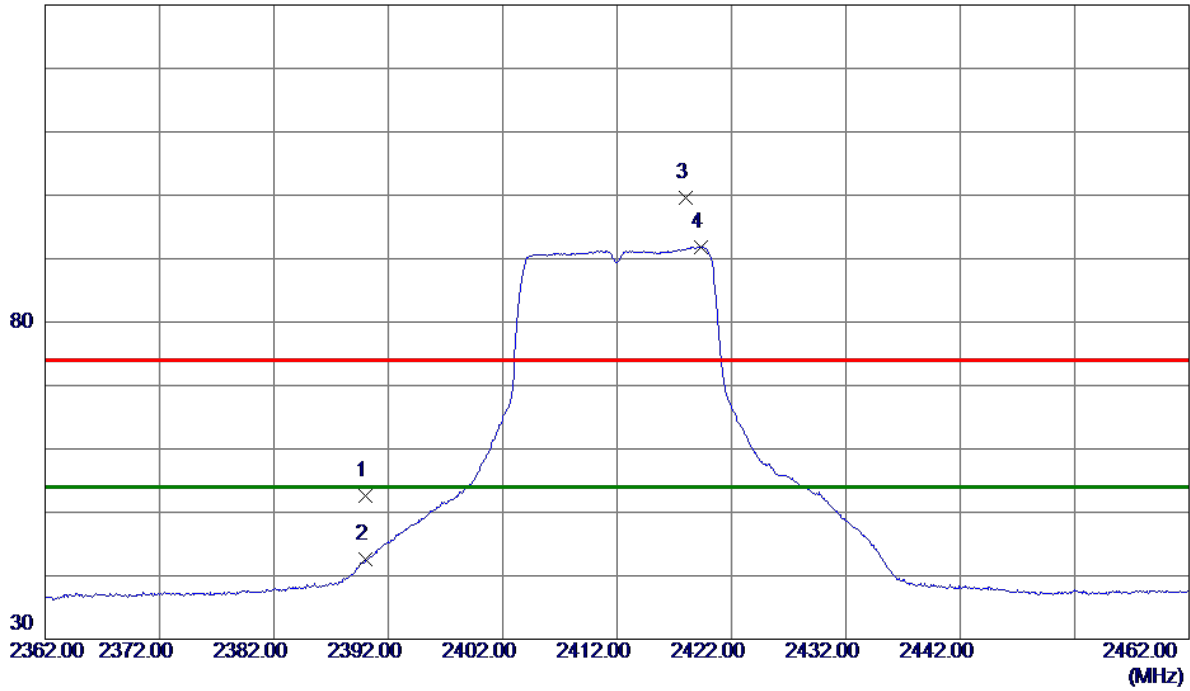

No.	Freq. MHz	Reading Level dBuV/m	Correct Factor dB	Measure ment dBuV/m	Limit dBuV/m	Margin dB	Detector	Comment
1	2390.0000	46.02	6.62	52.64	74.00	-21.36	Peak	
2	2390.0000	35.91	6.62	42.53	54.00	-11.47	AVG	
3	2418.0000	93.05	6.62	99.67	74.00	25.67	Peak	No Limit
4 *	2419.3500	85.19	6.62	91.81	54.00	37.81	AVG	No Limit



Orthogonal Axis	X
Test Mode:	TX G Mode 2412 MHz

**Horizontal**

80 dBuV/m

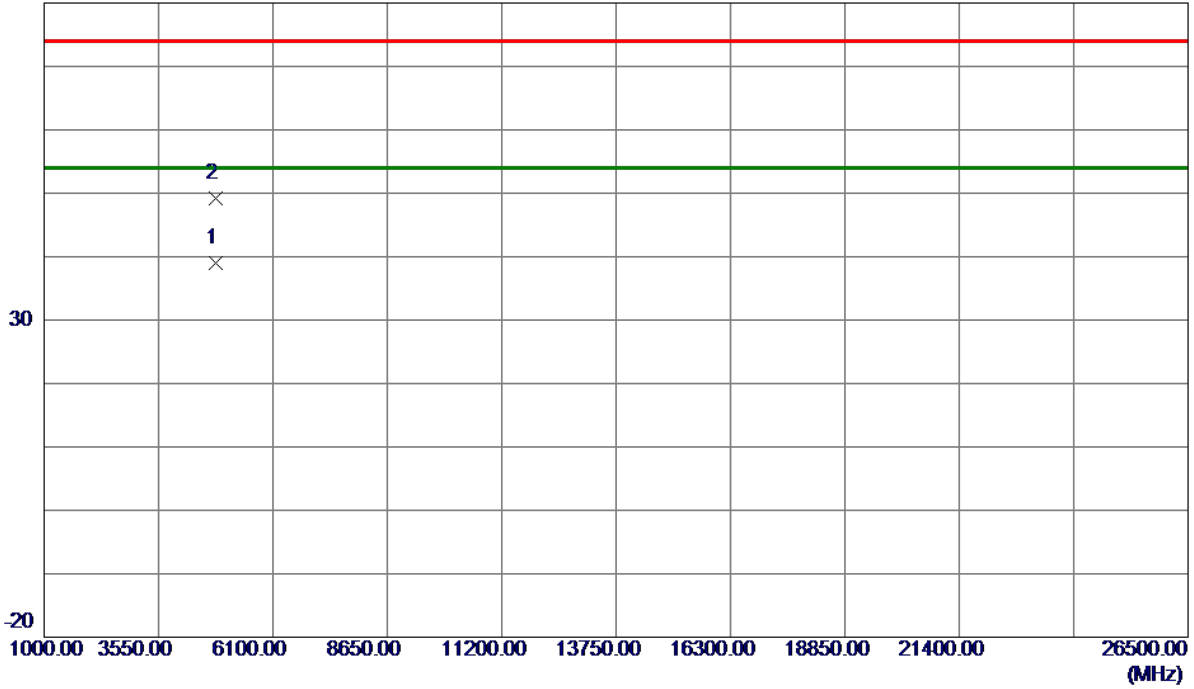

No.	Freq. MHz	Reading Level dBuV/m	Correct Factor dB	Measure ment dBuV/m	Limit dBuV/m	Margin dB	Detector	Comment
1 *	4824.0250	35.45	3.57	39.02	54.00	-14.98	AVG	
2	4822.4500	45.66	3.57	49.23	74.00	-24.77	Peak	

Orthogonal Axis	X
Test Mode:	TX G Mode 2437 MHz

**Vertical**

130 dBuV/m

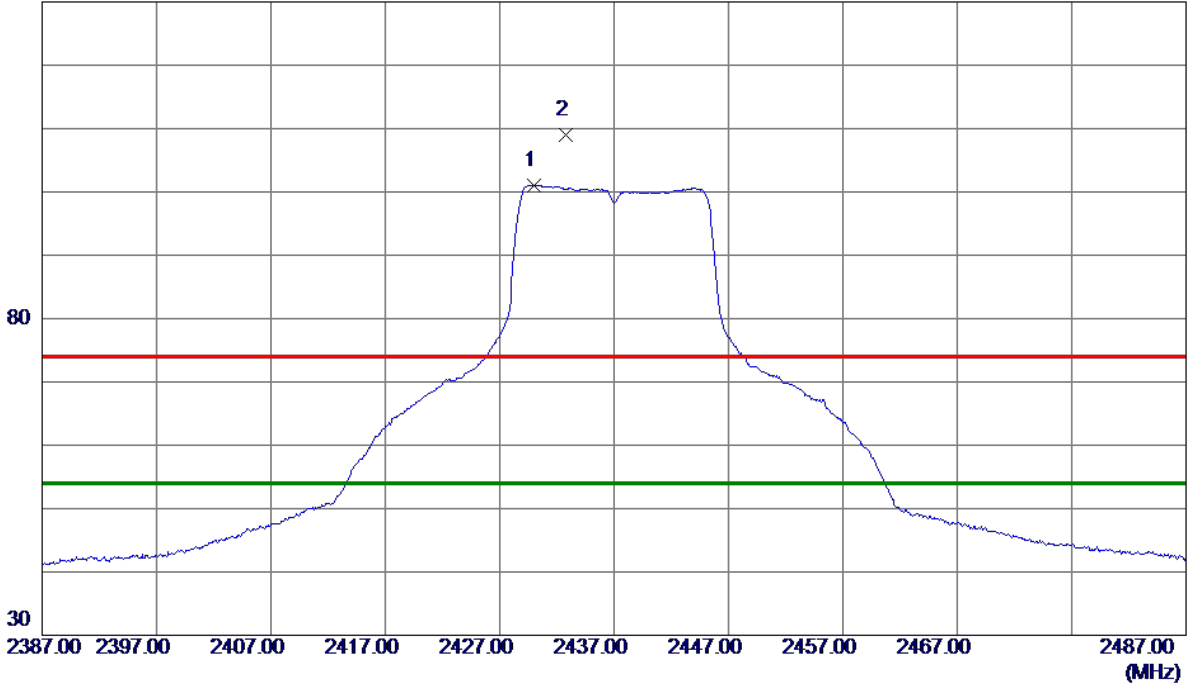

No.	Freq. MHz	Reading Level dBuV/m	Correct Factor dB	Measure ment dBuV/m	Limit dBuV/m	Margin dB	Detector	Comment
1 *	2430.0500	94.48	6.62	101.10	54.00	47.10	AVG	No Limit
2	2432.7500	102.48	6.62	109.10	74.00	35.10	Peak	No Limit

Orthogonal Axis	X
Test Mode:	TX G Mode 2437 MHz

**Vertical**

80 dBuV/m

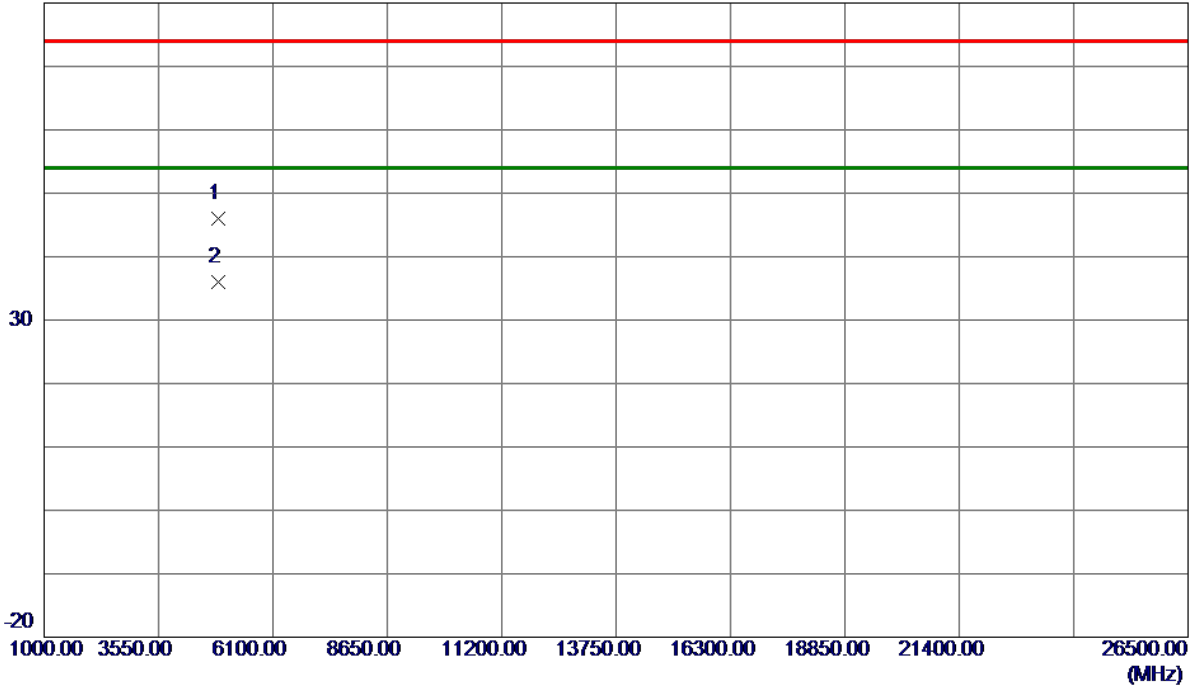

No.	Freq. MHz	Reading Level dBuV/m	Correct Factor dB	Measure ment dBuV/m	Limit dBuV/m	Margin dB	Detector	Comment
1	4872.3000	42.36	3.68	46.04	74.00	-27.96	Peak	
2 *	4873.2750	32.29	3.68	35.97	54.00	-18.03	AVG	

Orthogonal Axis	X
Test Mode:	TX G Mode 2437 MHz

**Horizontal**

130 dBuV/m

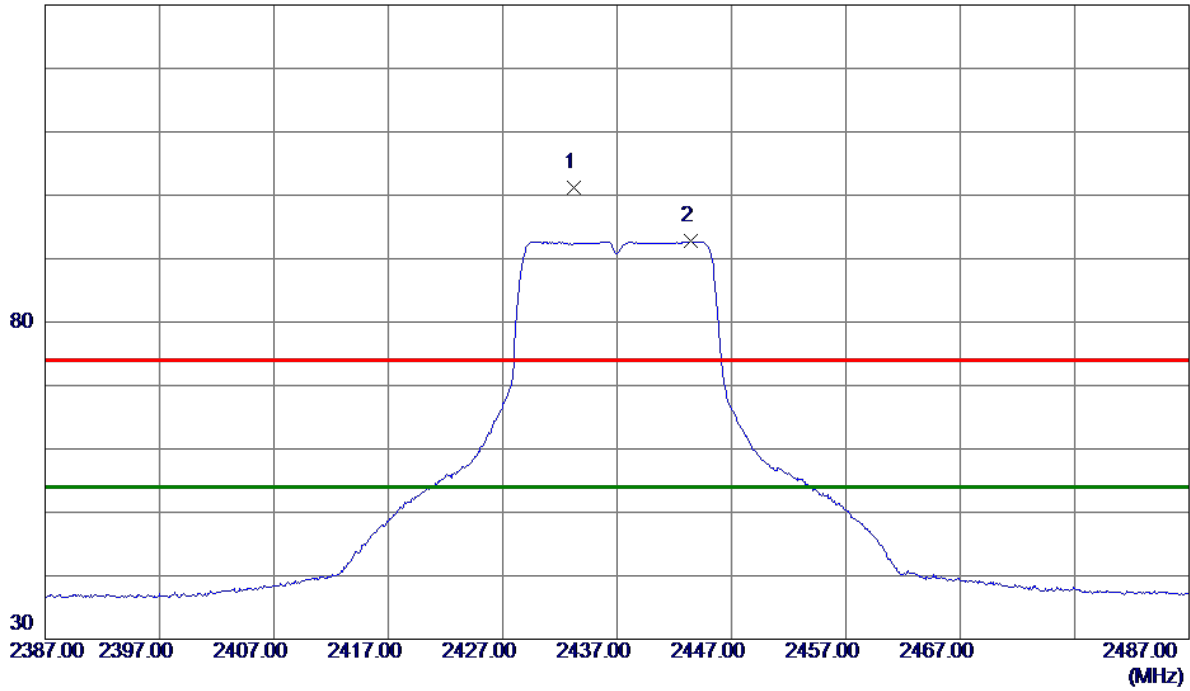

No.	Freq. MHz	Reading Level dBuV/m	Correct Factor dB	Measure ment dBuV/m	Limit dBuV/m	Margin dB	Detector	Comment
1	2433.2500	94.50	6.62	101.12	74.00	27.12	Peak	No Limit
2 *	2443.4000	86.18	6.61	92.79	54.00	38.79	AVG	No Limit

Orthogonal Axis	X
Test Mode:	TX G Mode 2437 MHz

**Horizontal**

80 dBuV/m

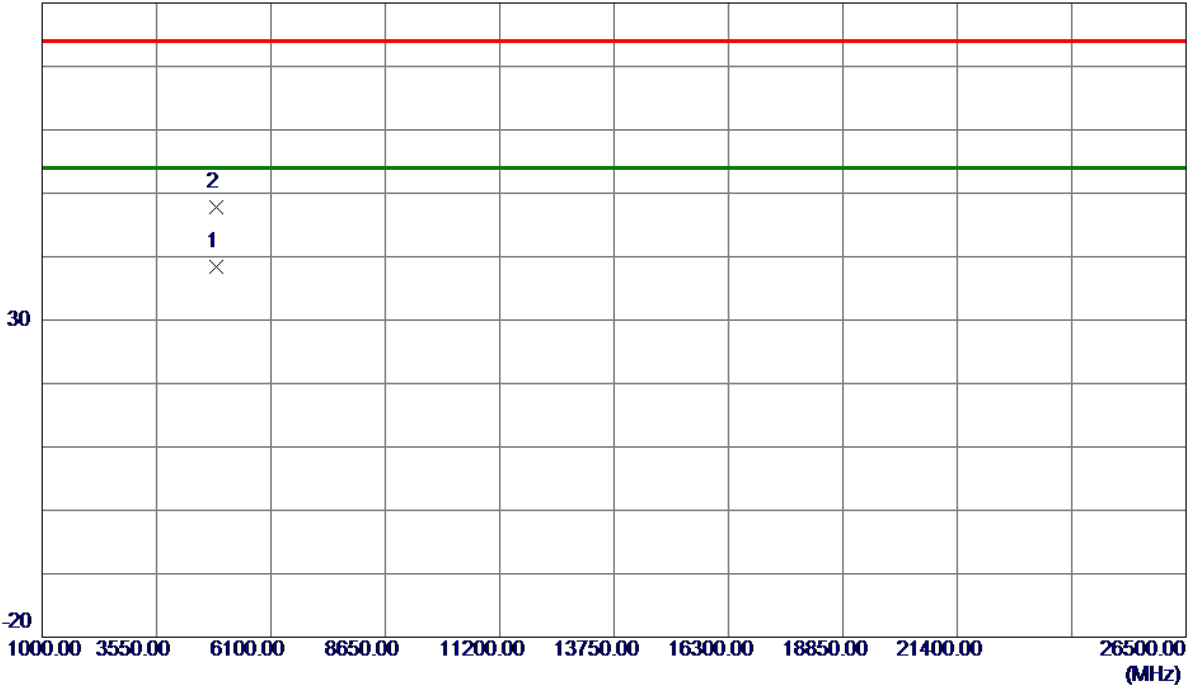

No.	Freq. MHz	Reading Level dBuV/m	Correct Factor dB	Measure ment dBuV/m	Limit dBuV/m	Margin dB	Detector	Comment
1 *	4873.2750	34.70	3.68	38.38	54.00	-15.62	AVG	
2	4873.7000	44.14	3.68	47.82	74.00	-26.18	Peak	

Orthogonal Axis	X
Test Mode:	TX G Mode 2462 MHz

**Vertical**

130 dBuV/m

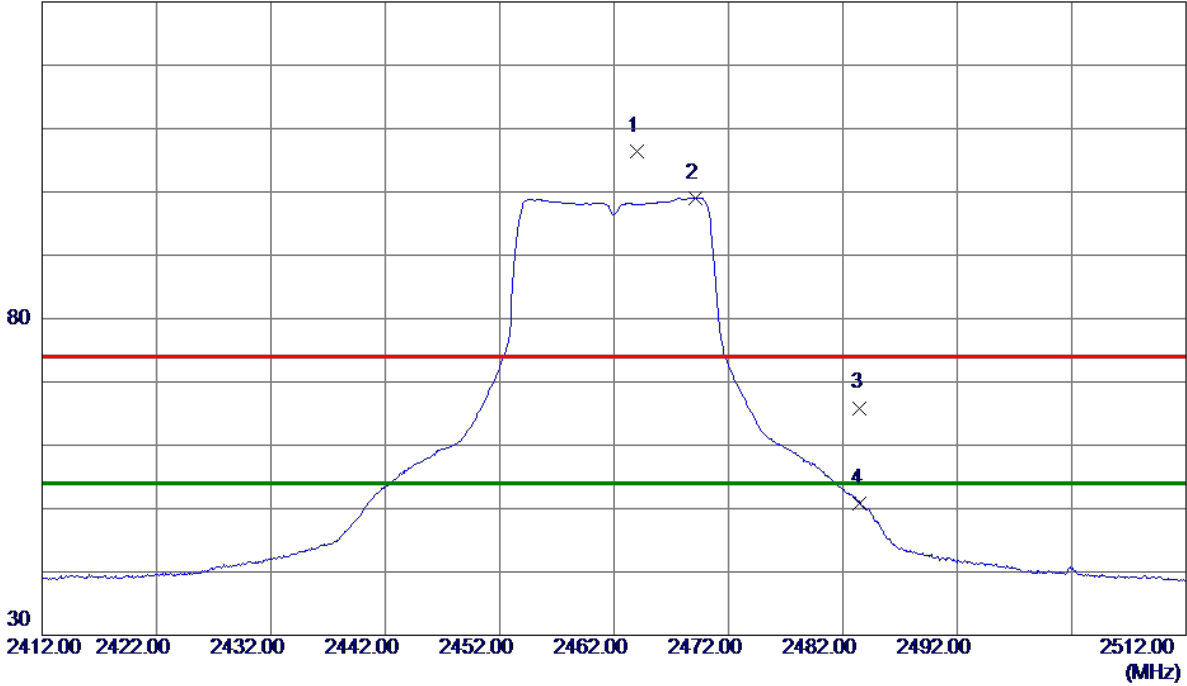

No.	Freq. MHz	Reading Level dBuV/m	Correct Factor dB	Measure ment dBuV/m	Limit dBuV/m	Margin dB	Detector	Comment
1	2464.0500	99.78	6.61	106.39	74.00	32.39	Peak	No Limit
2 *	2469.1500	92.49	6.61	99.10	54.00	45.10	AVG	No Limit
3	2483.5000	59.29	6.61	65.90	74.00	-8.10	Peak	
4	2483.5000	44.25	6.61	50.86	54.00	-3.14	AVG	

Orthogonal Axis	X
Test Mode:	TX G Mode 2462 MHz

**Vertical**

80 dBuV/m

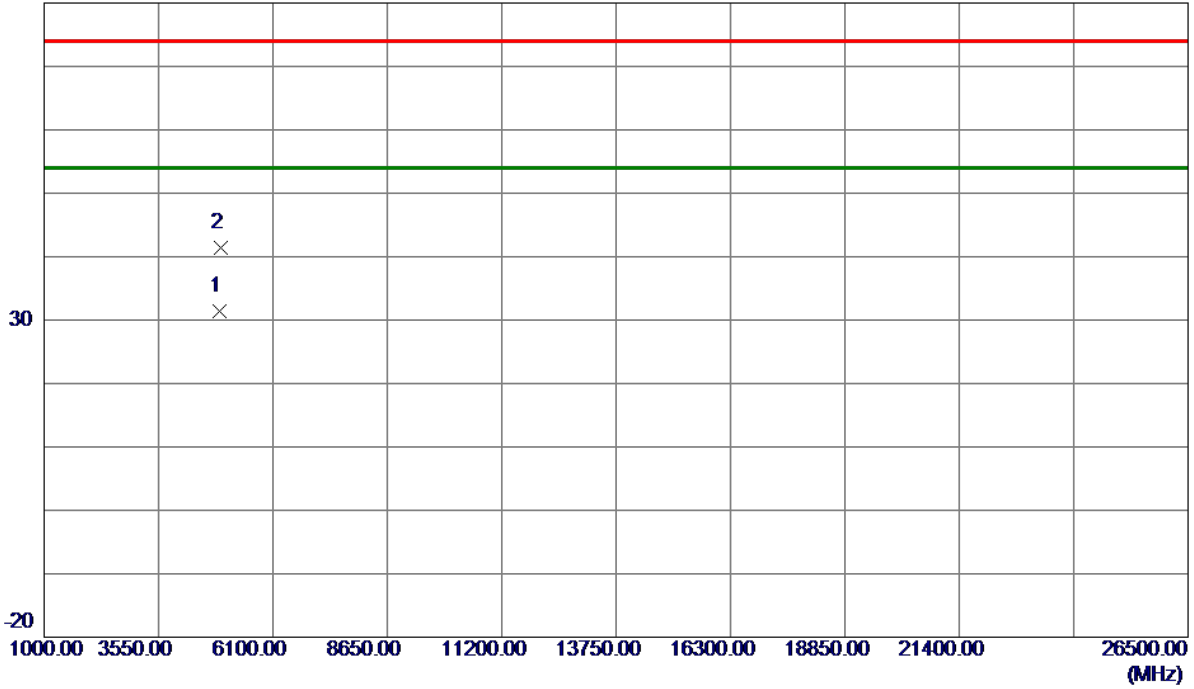

No.	Freq. MHz	Reading Level dBuV/m	Correct Factor dB	Measure ment dBuV/m	Limit dBuV/m	Margin dB	Detector	Comment
1 *	4923.9000	27.59	3.79	31.38	54.00	-22.62	AVG	
2	4927.6000	37.57	3.80	41.37	74.00	-32.63	Peak	

Orthogonal Axis	X
Test Mode:	TX G Mode 2462 MHz

**Horizontal**

130 dBuV/m

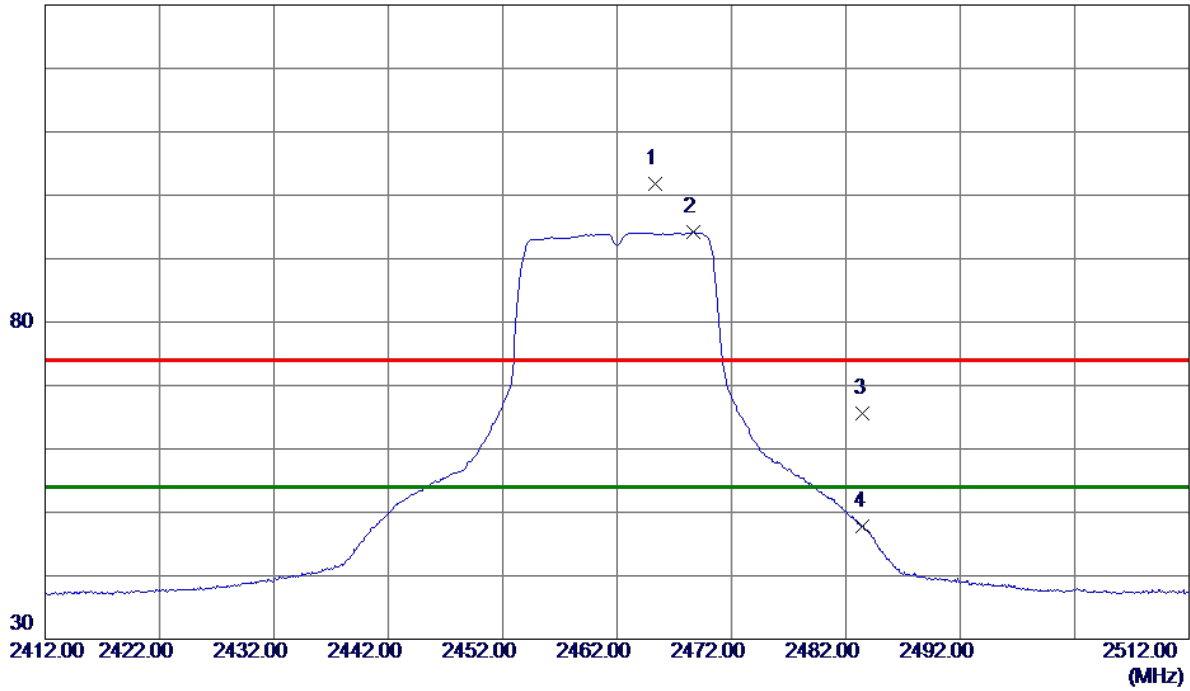

No.	Freq. MHz	Reading Level dBuV/m	Correct Factor dB	Measure ment dBuV/m	Limit dBuV/m	Margin dB	Detector	Comment
1	2465.3000	95.19	6.61	101.80	74.00	27.80	Peak	No Limit
2 *	2468.6500	87.53	6.61	94.14	54.00	40.14	AVG	No Limit
3	2483.5000	58.98	6.61	65.59	74.00	-8.41	Peak	
4	2483.5000	41.14	6.61	47.75	54.00	-6.25	AVG	



Orthogonal Axis	X
Test Mode:	TX G Mode 2462 MHz

**Horizontal**

80 dBuV/m

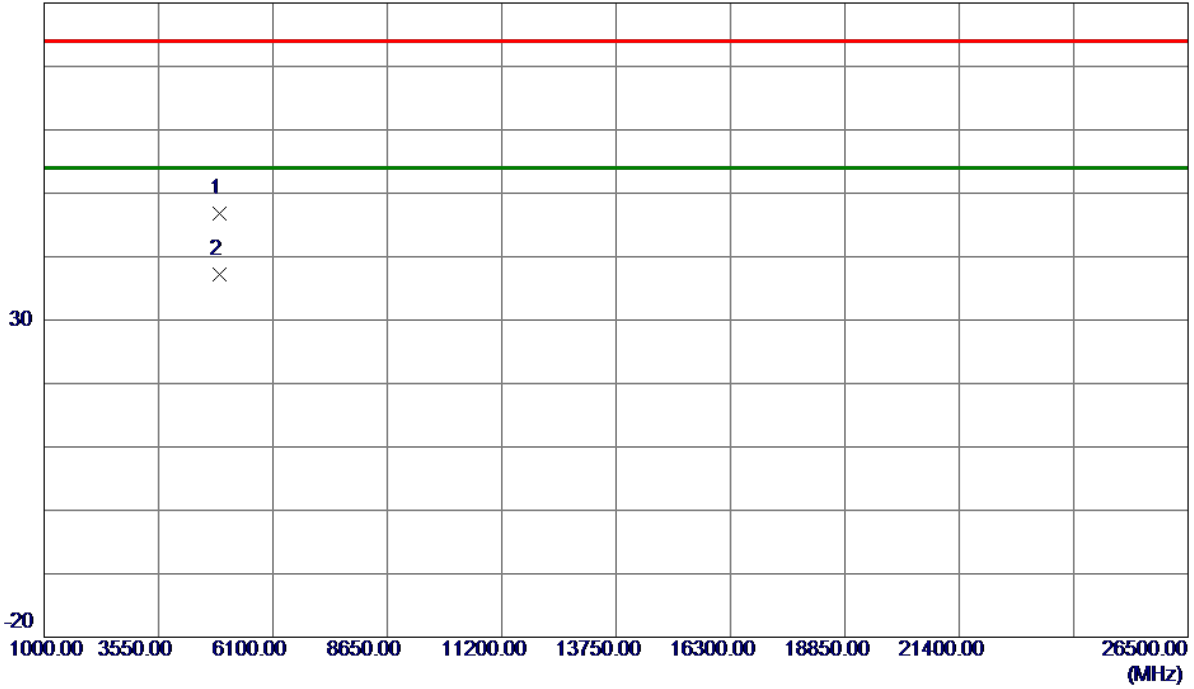

No.	Freq. MHz	Reading Level dBuV/m	Correct Factor dB	Measure ment dBuV/m	Limit dBuV/m	Margin dB	Detector	Comment
1	4918.3500	43.01	3.78	46.79	74.00	-27.21	Peak	
2 *	4923.9750	33.49	3.79	37.28	54.00	-16.72	AVG	

Orthogonal Axis	X
Test Mode:	TX N-20M Mode 2412 MHz

**Vertical**

130 dBuV/m

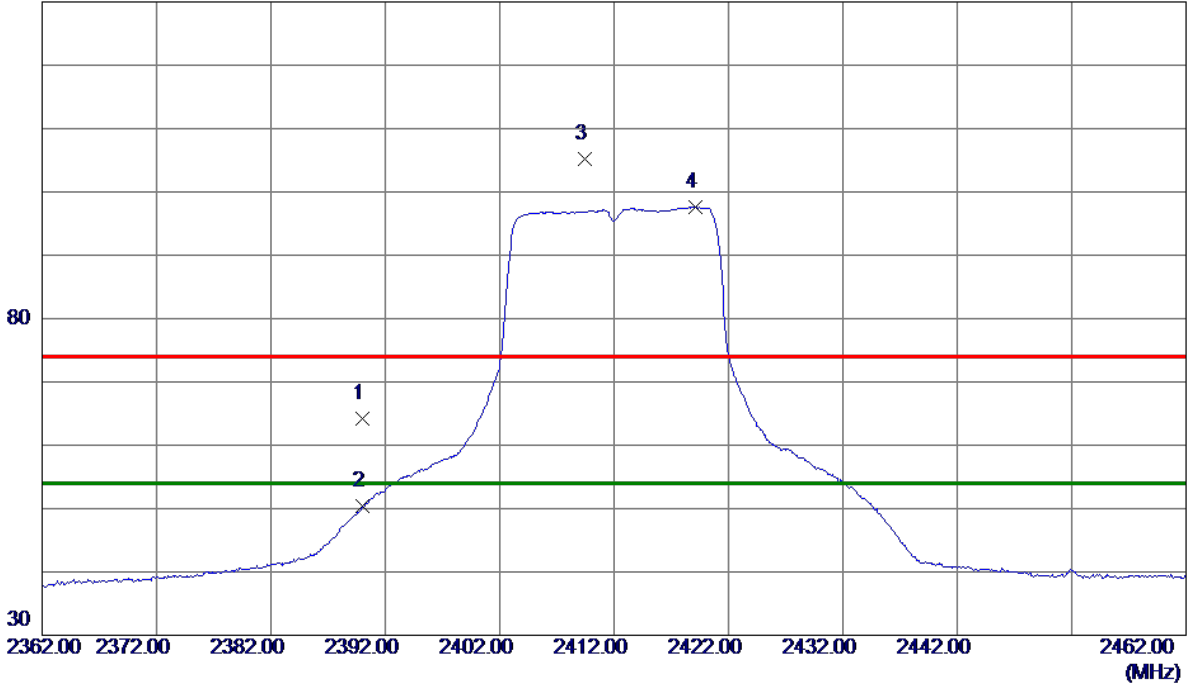

No.	Freq. MHz	Reading Level dBuV/m	Correct Factor dB	Measure ment dBuV/m	Limit dBuV/m	Margin dB	Detector	Comment
1	2390.0000	57.66	6.62	64.28	74.00	-9.72	Peak	
2	2390.0000	43.69	6.62	50.31	54.00	-3.69	AVG	
3	2409.4500	98.61	6.62	105.23	74.00	31.23	Peak	No Limit
4 *	2419.1500	90.94	6.62	97.56	54.00	43.56	AVG	No Limit

Orthogonal Axis	X
Test Mode:	TX N-20M Mode 2412 MHz

**Vertical**

80 dBuV/m

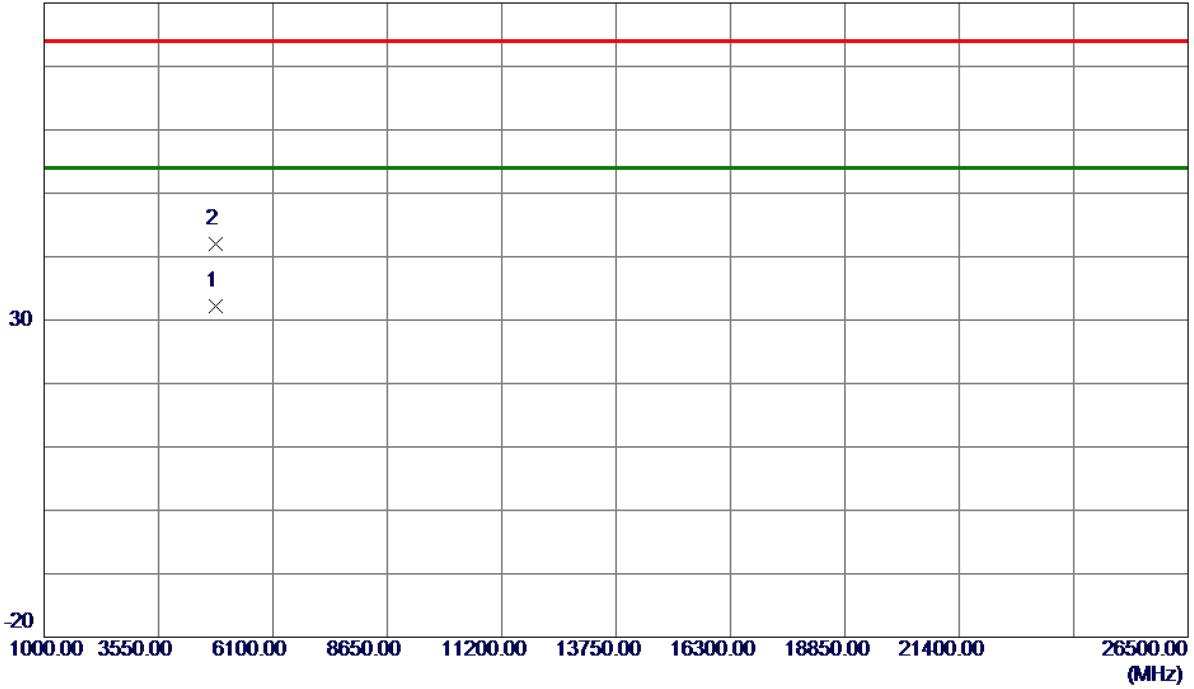

No.	Freq. MHz	Reading Level dBuV/m	Correct Factor dB	Measure ment dBuV/m	Limit dBuV/m	Margin dB	Detector	Comment
1 *	4823.8000	28.61	3.57	32.18	54.00	-21.82	AVG	
2	4824.7250	38.34	3.57	41.91	74.00	-32.09	Peak	

Orthogonal Axis	X
Test Mode:	TX N-20M Mode 2412 MHz

**Horizontal**

130 dBuV/m

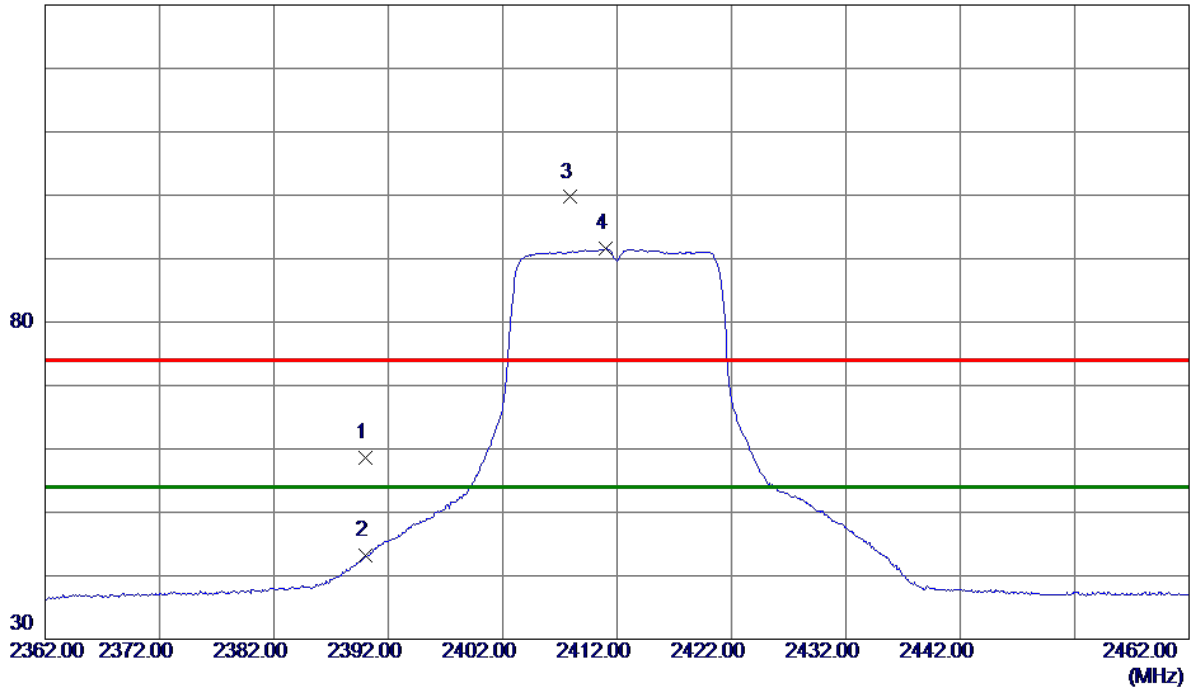

No.	Freq. MHz	Reading Level dBuV/m	Correct Factor dB	Measure ment dBuV/m	Limit dBuV/m	Margin dB	Detector	Comment
1	2390.0000	52.03	6.62	58.65	74.00	-15.35	Peak	
2	2390.0000	36.53	6.62	43.15	54.00	-10.85	AVG	
3	2407.8500	93.08	6.62	99.70	74.00	25.70	Peak	No Limit
4 *	2411.0500	84.92	6.62	91.54	54.00	37.54	AVG	No Limit

Orthogonal Axis	X
Test Mode:	TX N-20M Mode 2412 MHz

**Horizontal**

80 dBuV/m

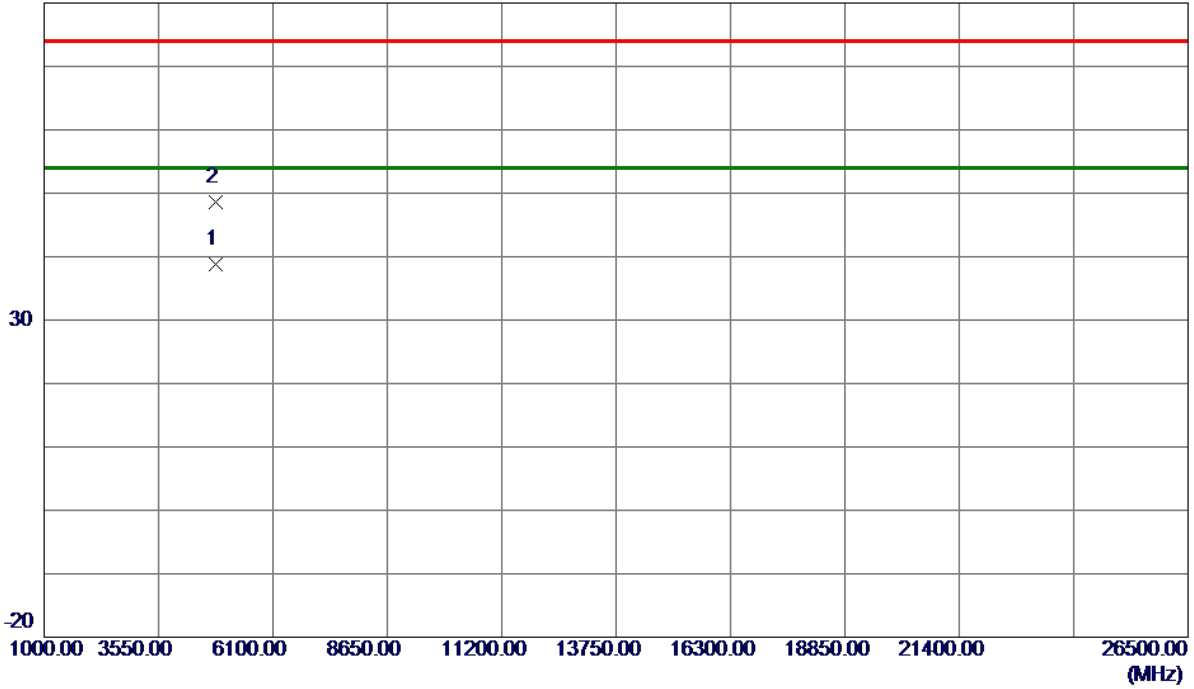

No.	Freq. MHz	Reading Level dBuV/m	Correct Factor dB	Measure ment dBuV/m	Limit dBuV/m	Margin dB	Detector	Comment
1 *	4823.9000	35.19	3.57	38.76	54.00	-15.24	AVG	
2	4825.6750	45.03	3.57	48.60	74.00	-25.40	Peak	

Orthogonal Axis	X
Test Mode:	TX N-20M Mode 2437 MHz

**Vertical**

130 dBuV/m

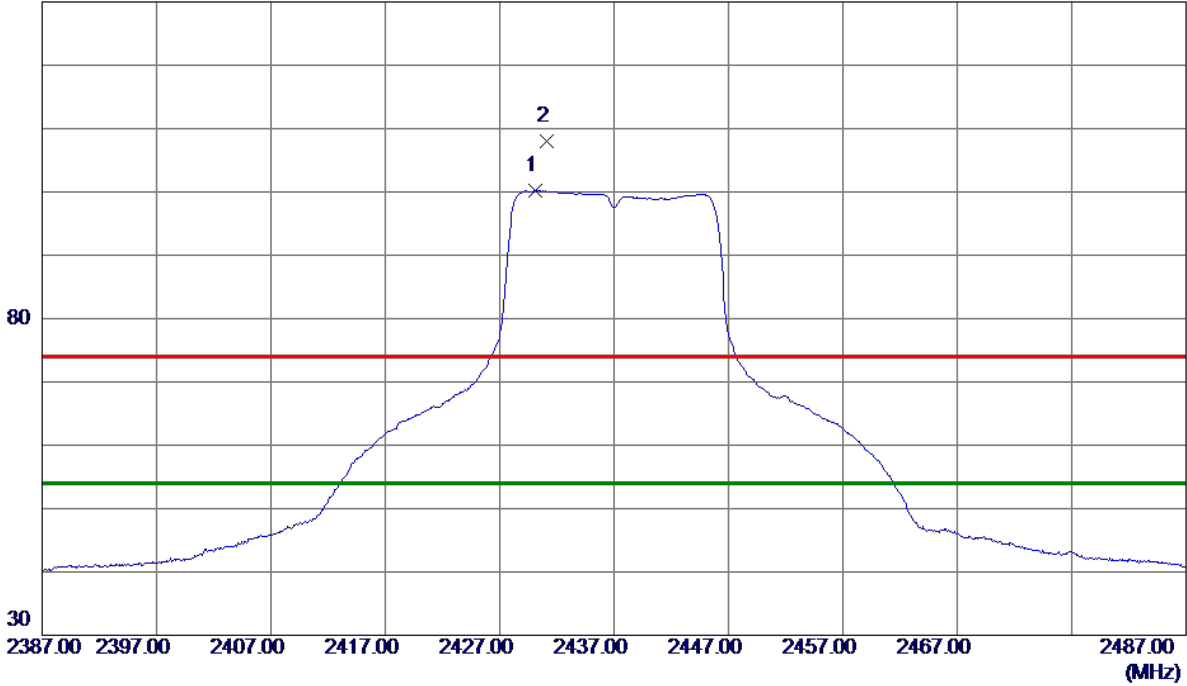

No.	Freq. MHz	Reading Level dBuV/m	Correct Factor dB	Measure ment dBuV/m	Limit dBuV/m	Margin dB	Detector	Comment
1 *	2430.1500	93.65	6.62	100.27	54.00	46.27	AVG	No Limit
2	2431.1500	101.38	6.62	108.00	74.00	34.00	Peak	No Limit

Orthogonal Axis	X
Test Mode:	TX N-20M Mode 2437 MHz

**Vertical**

80 dBuV/m

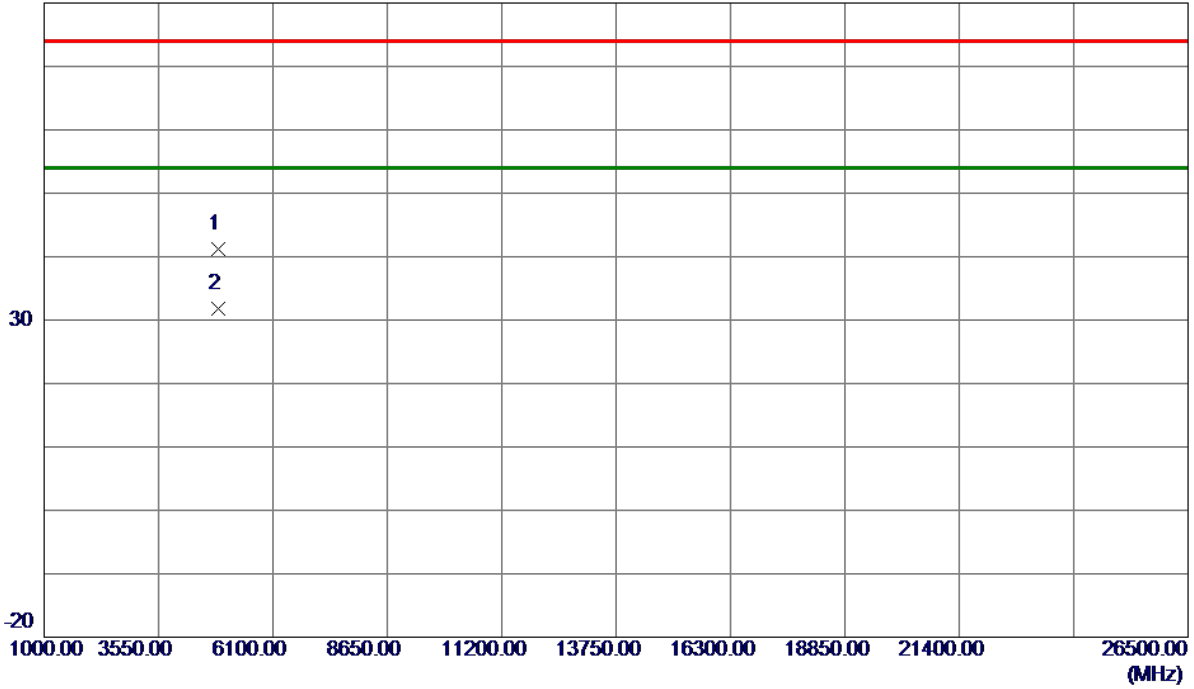

No.	Freq. MHz	Reading Level dBuV/m	Correct Factor dB	Measure ment dBuV/m	Limit dBuV/m	Margin dB	Detector	Comment
1	4873.5000	37.45	3.68	41.13	74.00	-32.87	Peak	
2 *	4873.9750	28.13	3.68	31.81	54.00	-22.19	AVG	

Orthogonal Axis	X
Test Mode:	TX N-20M Mode 2437 MHz

**Horizontal**

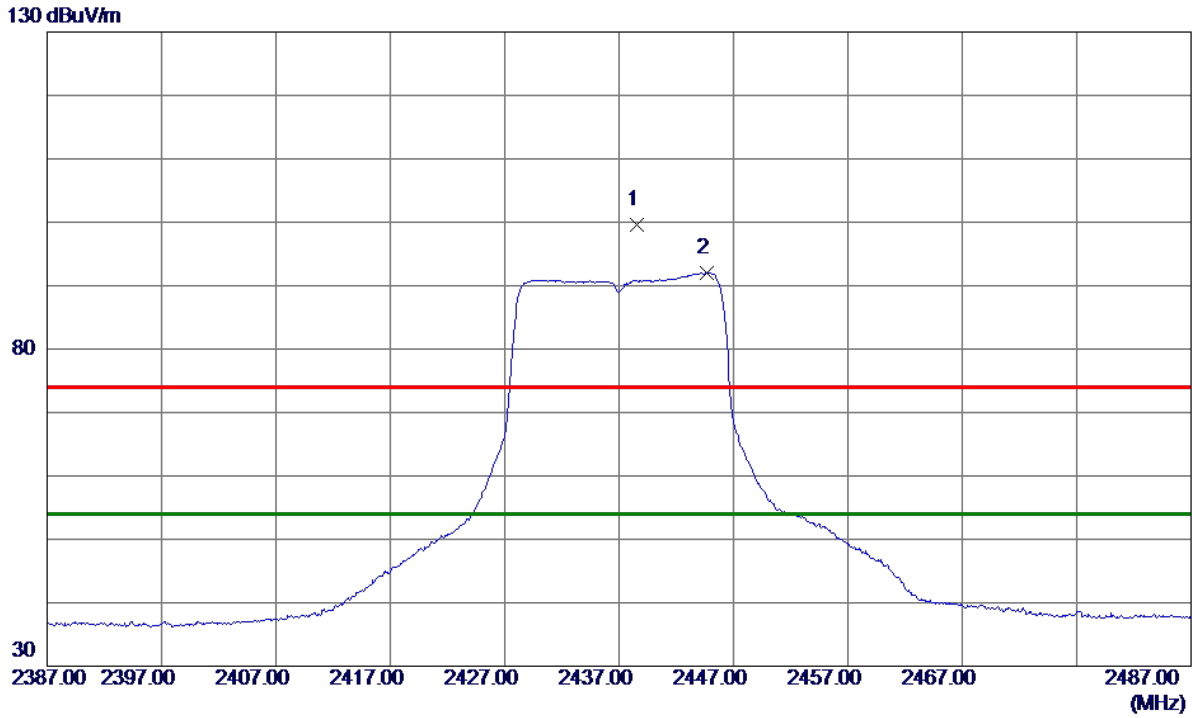

No.	Freq. MHz	Reading Level dBuV/m	Correct Factor dB	Measure ment dBuV/m	Limit dBuV/m	Margin dB	Detector	Comment
1	2438.6000	93.05	6.61	99.66	74.00	25.66	Peak	No Limit
2 *	2444.7000	85.32	6.61	91.93	54.00	37.93	AVG	No Limit



Orthogonal Axis	X
Test Mode:	TX N-20M Mode 2437 MHz

**Horizontal**

80 dBuV/m

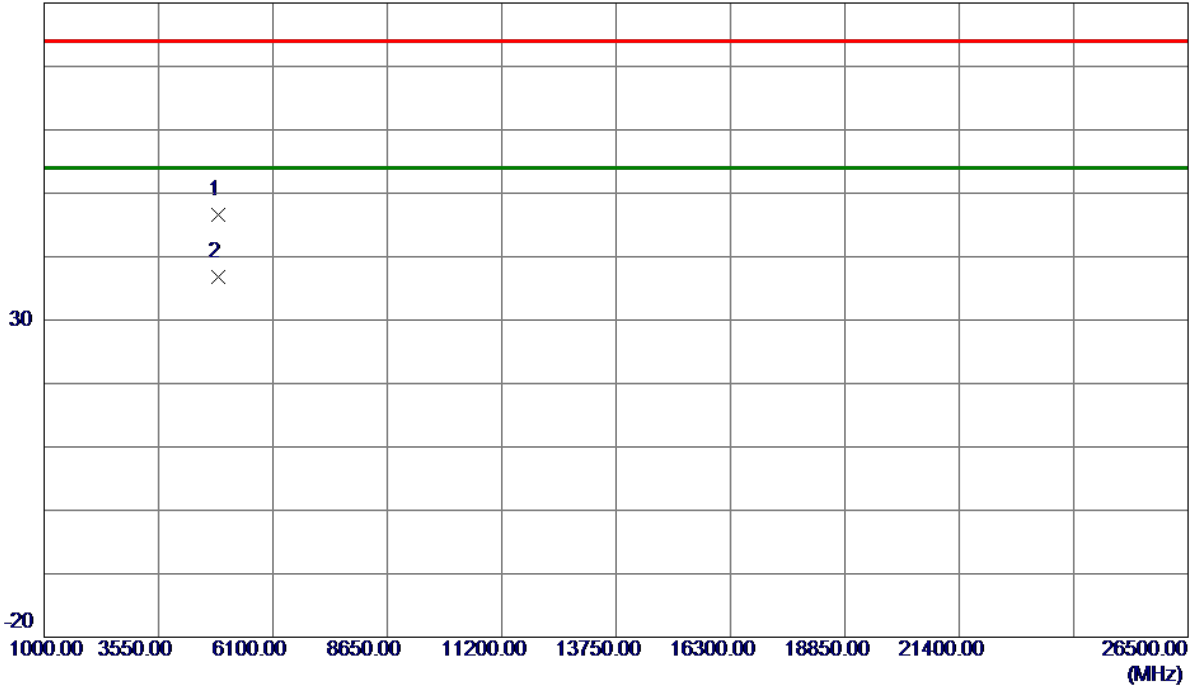

No.	Freq. MHz	Reading Level dBuV/m	Correct Factor dB	Measure ment dBuV/m	Limit dBuV/m	Margin dB	Detector	Comment
1	4870.8500	42.94	3.67	46.61	74.00	-27.39	Peak	
2 *	4873.1750	33.04	3.68	36.72	54.00	-17.28	AVG	

Orthogonal Axis	X
Test Mode:	TX N-20M Mode 2462 MHz

**Vertical**

130 dBuV/m

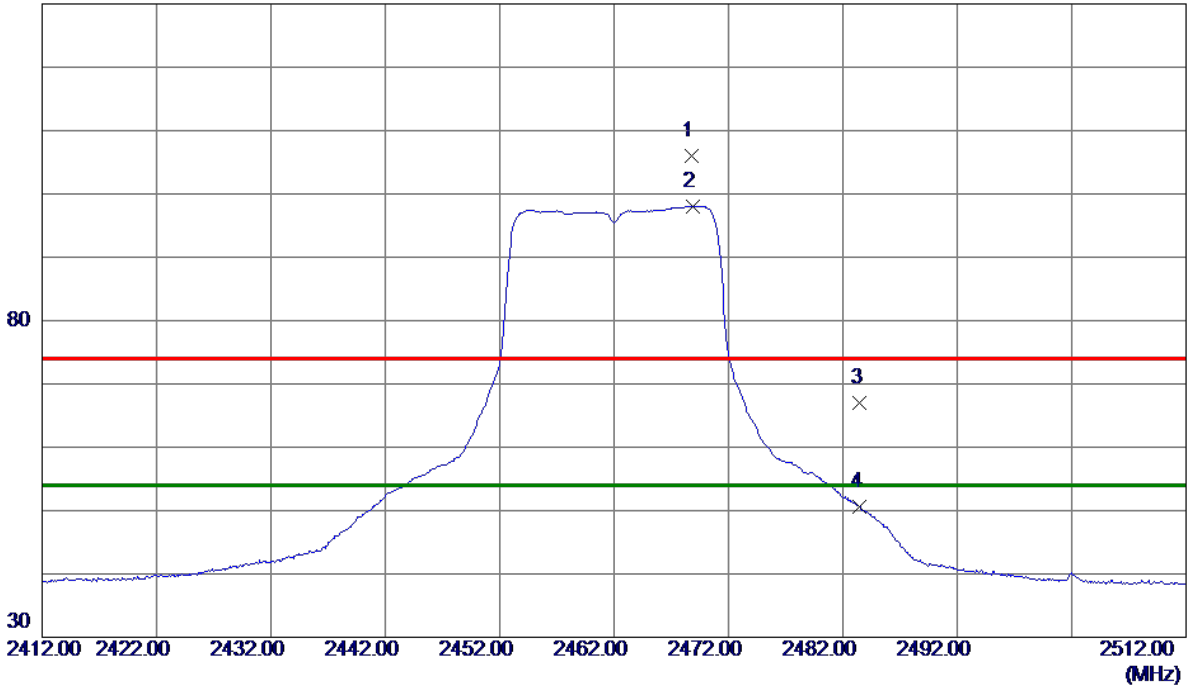

No.	Freq. MHz	Reading Level dBuV/m	Correct Factor dB	Measure ment dBuV/m	Limit dBuV/m	Margin dB	Detector	Comment
1	2468.8000	99.45	6.61	106.06	74.00	32.06	Peak	No Limit
2 *	2468.8500	91.40	6.61	98.01	54.00	44.01	AVG	No Limit
3	2483.5000	60.46	6.61	67.07	74.00	-6.93	Peak	
4	2483.5000	43.90	6.61	50.51	54.00	-3.49	AVG	

Orthogonal Axis	X
Test Mode:	TX N-20M Mode 2462 MHz

**Vertical**

80 dBuV/m

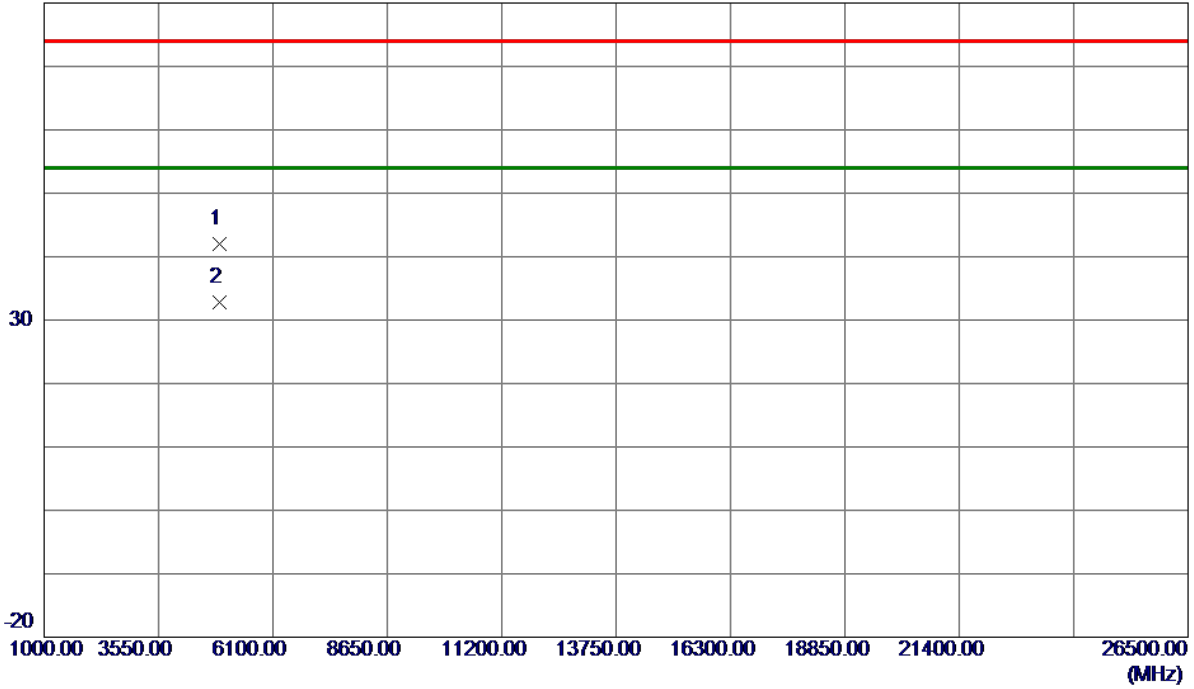

No.	Freq. MHz	Reading Level dBuV/m	Correct Factor dB	Measure ment dBuV/m	Limit dBuV/m	Margin dB	Detector	Comment
1	4923.2000	38.24	3.79	42.03	74.00	-31.97	Peak	
2 *	4923.8500	28.92	3.79	32.71	54.00	-21.29	AVG	

Orthogonal Axis	X
Test Mode:	TX N-20M Mode 2462 MHz

**Horizontal**

130 dBuV/m

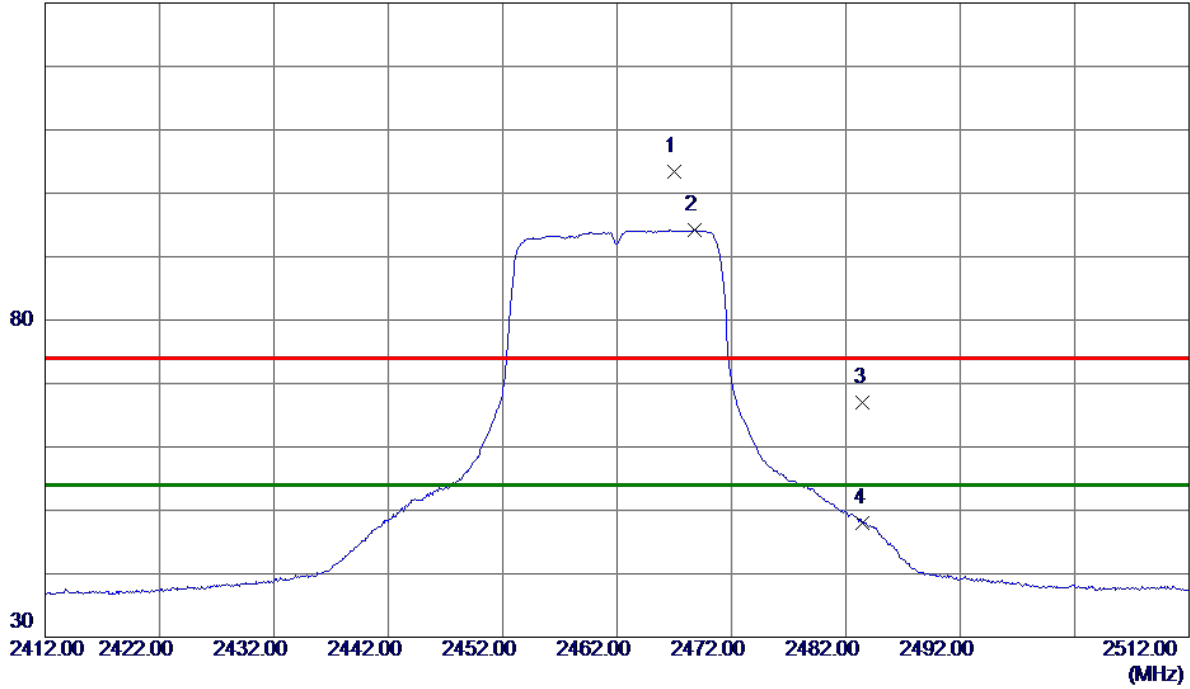

No.	Freq. MHz	Reading Level dBuV/m	Correct Factor dB	Measure ment dBuV/m	Limit dBuV/m	Margin dB	Detector	Comment
1	2467.0500	96.79	6.61	103.40	74.00	29.40	Peak	No Limit
2 *	2468.8000	87.55	6.61	94.16	54.00	40.16	AVG	No Limit
3	2483.5000	60.43	6.61	67.04	74.00	-6.96	Peak	
4	2483.5000	41.38	6.61	47.99	54.00	-6.01	AVG	

Orthogonal Axis	X
Test Mode:	TX N-20M Mode 2462 MHz

**Horizontal**

80 dBuV/m

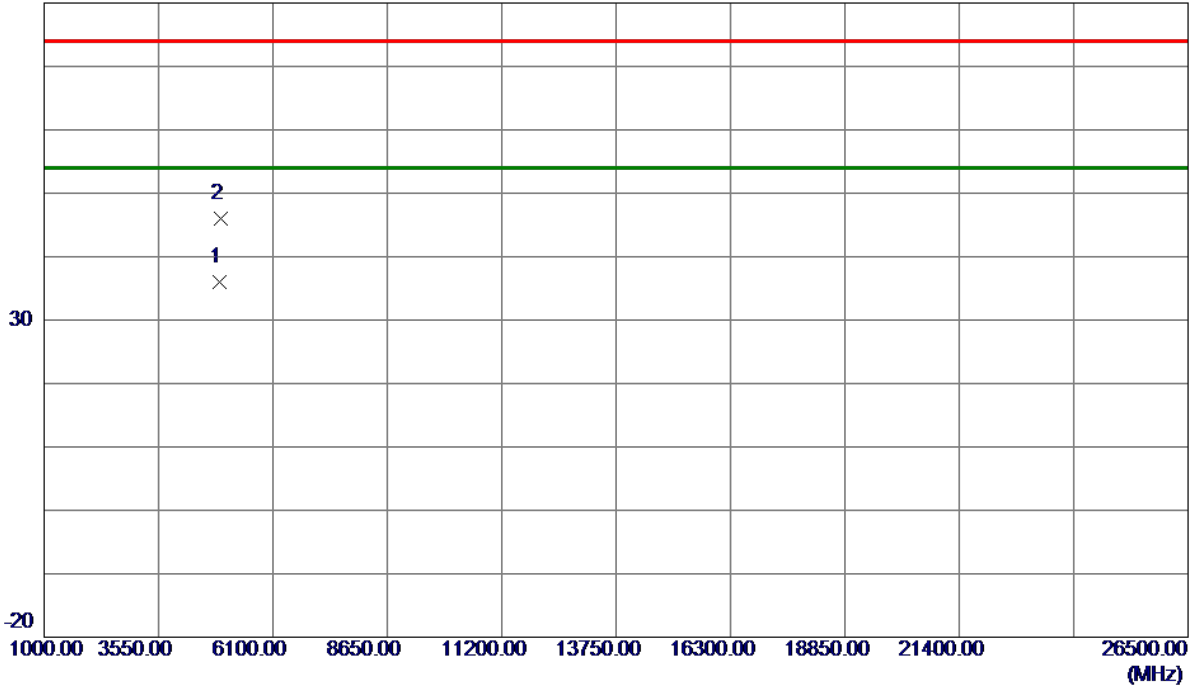

No.	Freq. MHz	Reading Level dBuV/m	Correct Factor dB	Measure ment dBuV/m	Limit dBuV/m	Margin dB	Detector	Comment
1 *	4923.8750	32.22	3.79	36.01	54.00	-17.99	AVG	
2	4928.9250	42.22	3.80	46.02	74.00	-27.98	Peak	

Orthogonal Axis	X
Test Mode:	TX N-40M Mode 2422MHz

**Vertical**

130 dBuV/m

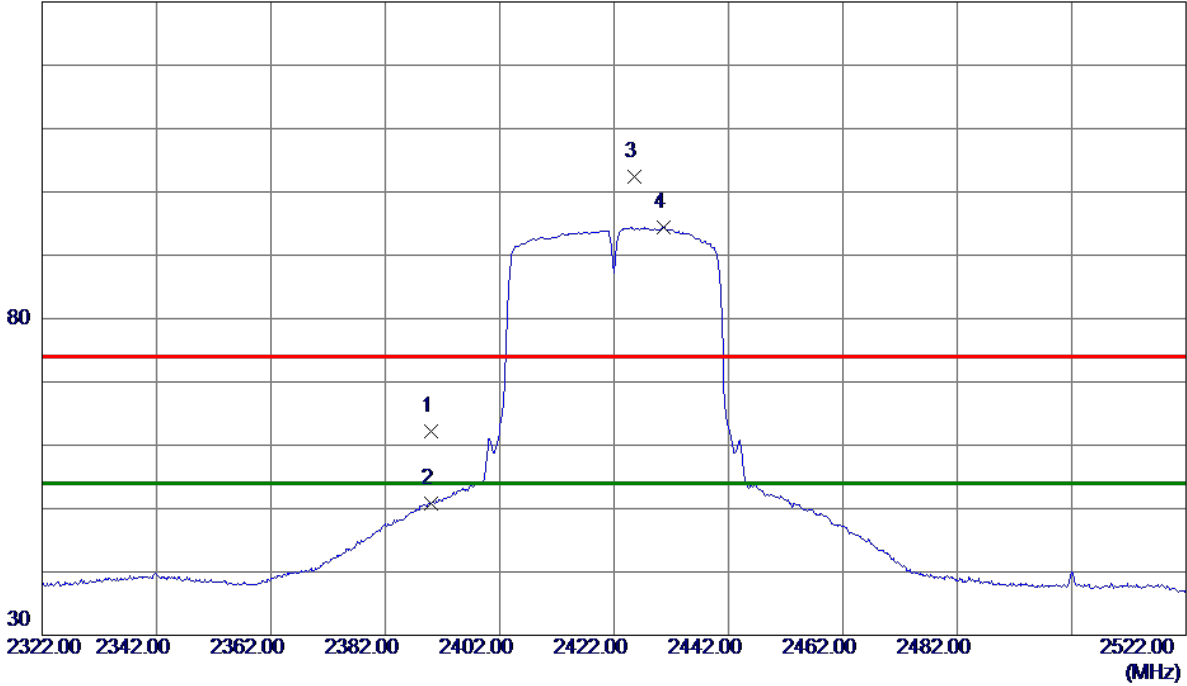

No.	Freq. MHz	Reading Level dBuV/m	Correct Factor dB	Measure ment dBuV/m	Limit dBuV/m	Margin dB	Detector	Comment
1	2390.0000	55.50	6.62	62.12	74.00	-11.88	Peak	
2	2390.0000	44.22	6.62	50.84	54.00	-3.16	AVG	
3	2425.5000	95.74	6.62	102.36	74.00	28.36	Peak	No Limit
4 *	2430.6000	87.77	6.62	94.39	54.00	40.39	AVG	No Limit

Orthogonal Axis	X
Test Mode:	TX N-40M Mode 2422MHz

**Vertical**

80 dBuV/m

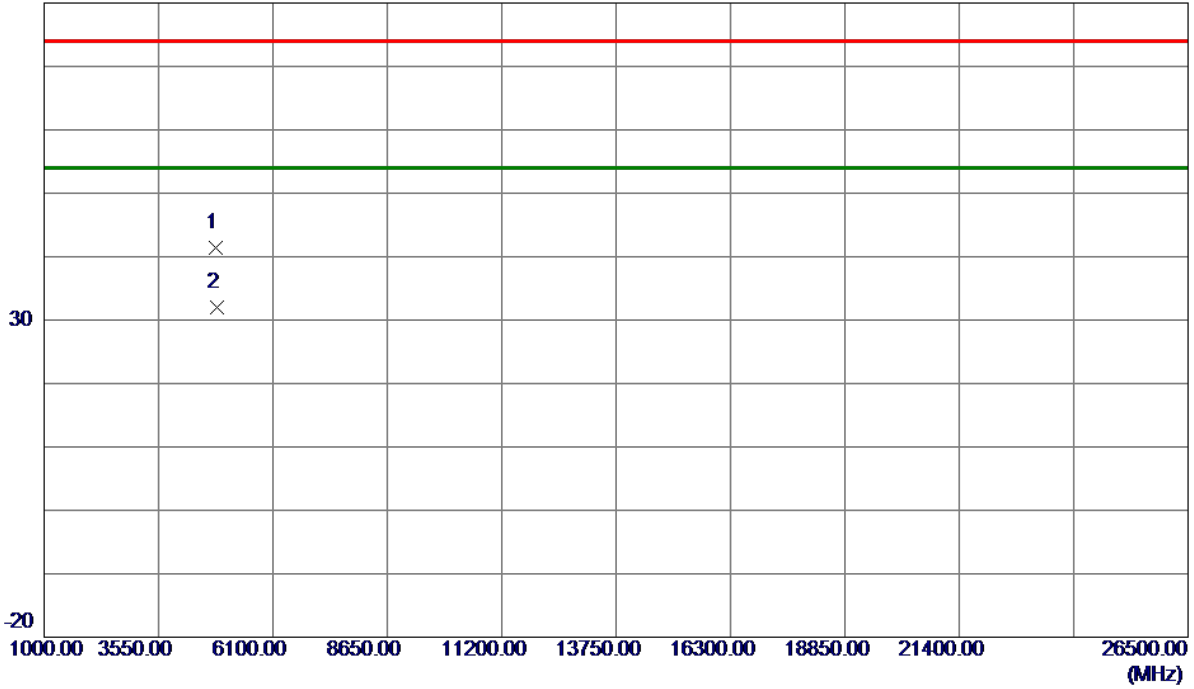

No.	Freq. MHz	Reading Level dBuV/m	Correct Factor dB	Measure ment dBuV/m	Limit dBuV/m	Margin dB	Detector	Comment
1	4831.2000	37.72	3.59	41.31	74.00	-32.69	Peak	
2 *	4843.9500	28.40	3.62	32.02	54.00	-21.98	AVG	

Orthogonal Axis	X
Test Mode:	TX N-40M Mode 2422MHz

### Horizontal

130 dBuV/m

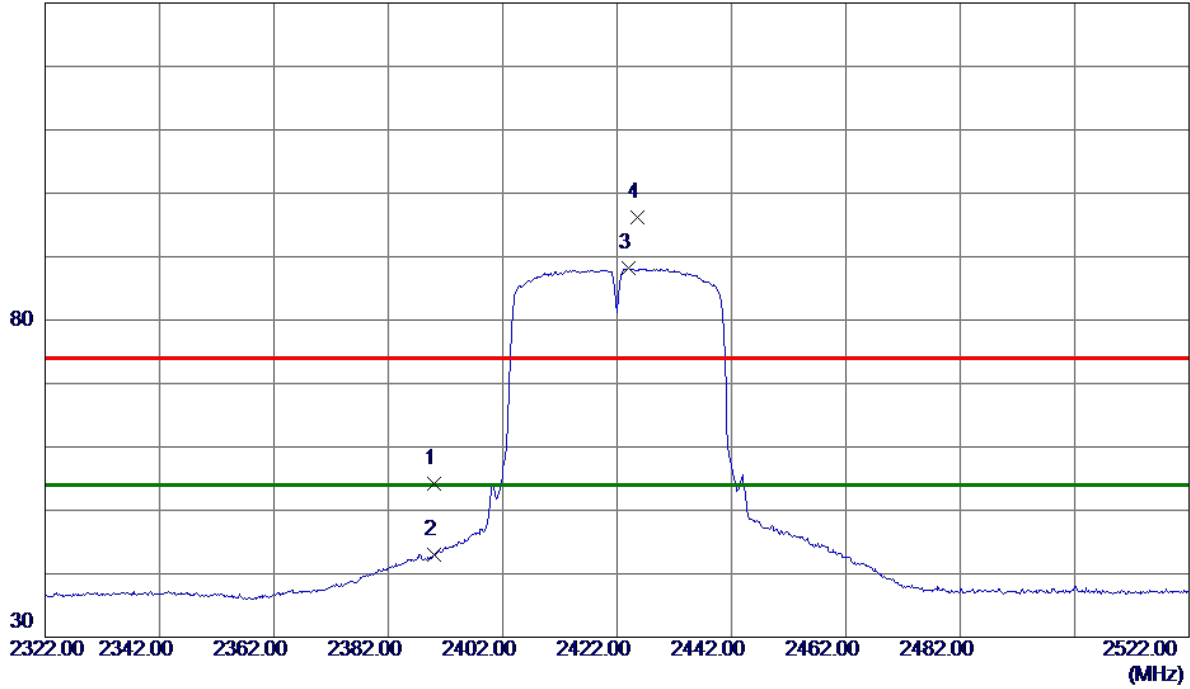

No.	Freq. MHz	Reading Level dBuV/m	Correct Factor dB	Measure ment dBuV/m	Limit dBuV/m	Margin dB	Detector	Comment
1	2390.0000	47.59	6.62	54.21	74.00	-19.79	Peak	
2	2390.0000	36.45	6.62	43.07	54.00	-10.93	AVG	
3 *	2424.0000	81.50	6.62	88.12	54.00	34.12	AVG	No Limit
4	2425.5000	89.66	6.62	96.28	74.00	22.28	Peak	No Limit



Orthogonal Axis	X
Test Mode:	TX N-40M Mode 2422MHz

**Horizontal**

80 dBuV/m

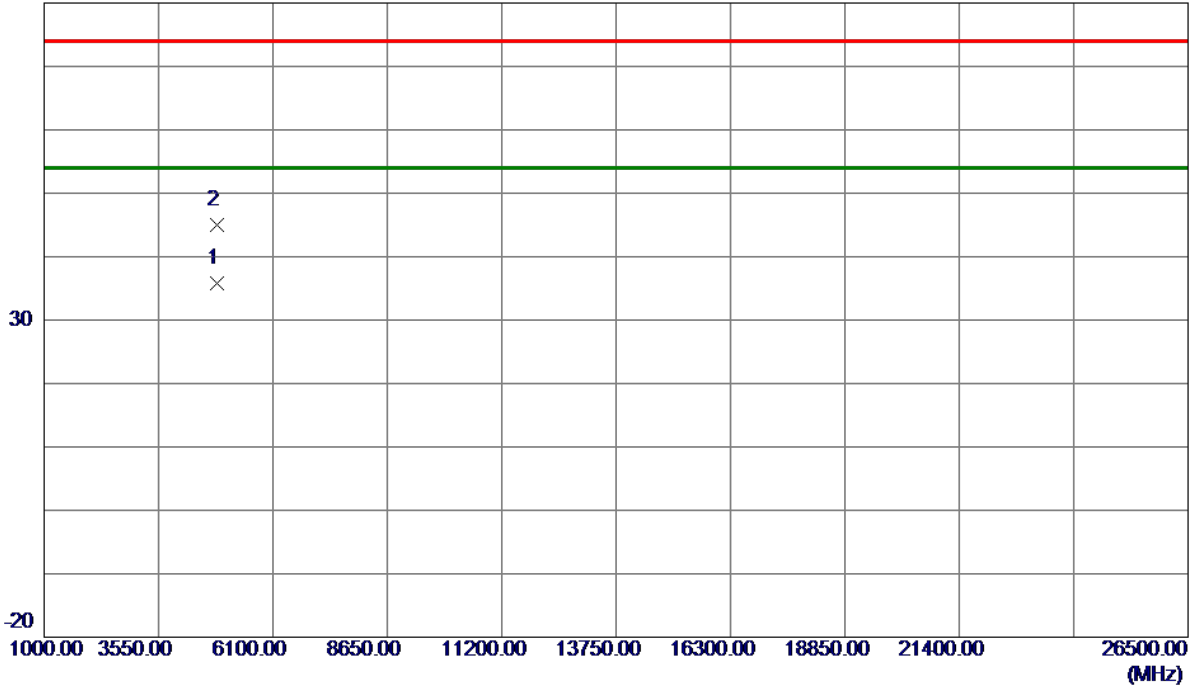

No.	Freq. MHz	Reading Level dBuV/m	Correct Factor dB	Measure ment dBuV/m	Limit dBuV/m	Margin dB	Detector	Comment
1 *	4843.9500	32.10	3.62	35.72	54.00	-18.28	AVG	
2	4845.8750	41.47	3.62	45.09	74.00	-28.91	Peak	

Orthogonal Axis	X
Test Mode:	TX N-40M Mode 2437 MHz

**Vertical**

130 dBuV/m

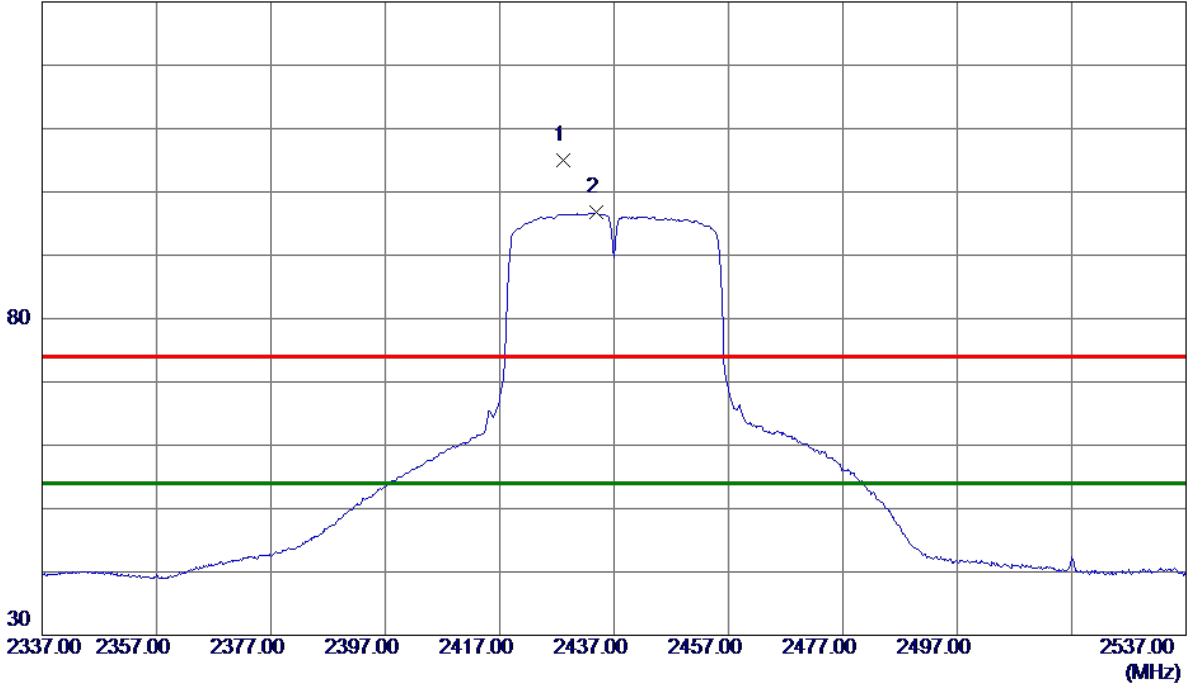

No.	Freq. MHz	Reading Level dBuV/m	Correct Factor dB	Measure ment dBuV/m	Limit dBuV/m	Margin dB	Detector	Comment
1	2428.2000	98.34	6.62	104.96	74.00	30.96	Peak	No Limit
2 *	2433.9000	90.10	6.61	96.71	54.00	42.71	AVG	No Limit

Orthogonal Axis	X
Test Mode:	TX N-40M Mode 2437 MHz

**Vertical**

80 dBuV/m

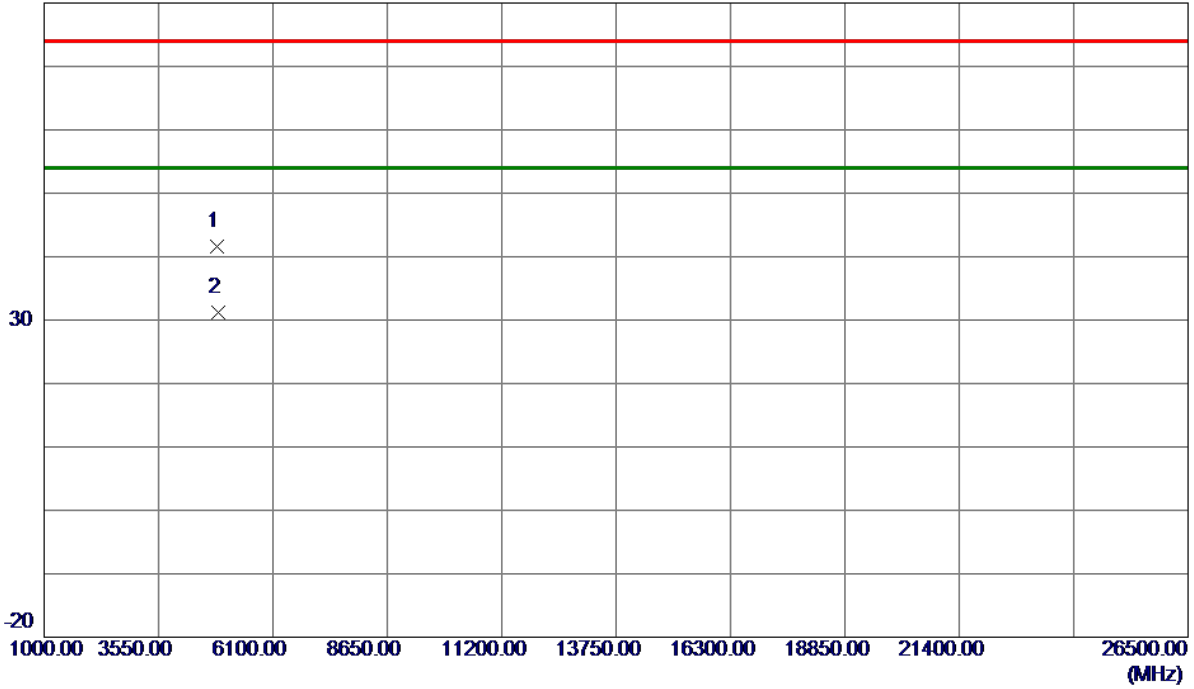

No.	Freq. MHz	Reading Level dBuV/m	Correct Factor dB	Measure ment dBuV/m	Limit dBuV/m	Margin dB	Detector	Comment
1	4862.8500	37.86	3.66	41.52	74.00	-32.48	Peak	
2 *	4874.1000	27.56	3.68	31.24	54.00	-22.76	AVG	

Orthogonal Axis	X
Test Mode:	TX N-40M Mode 2437 MHz

**Horizontal**

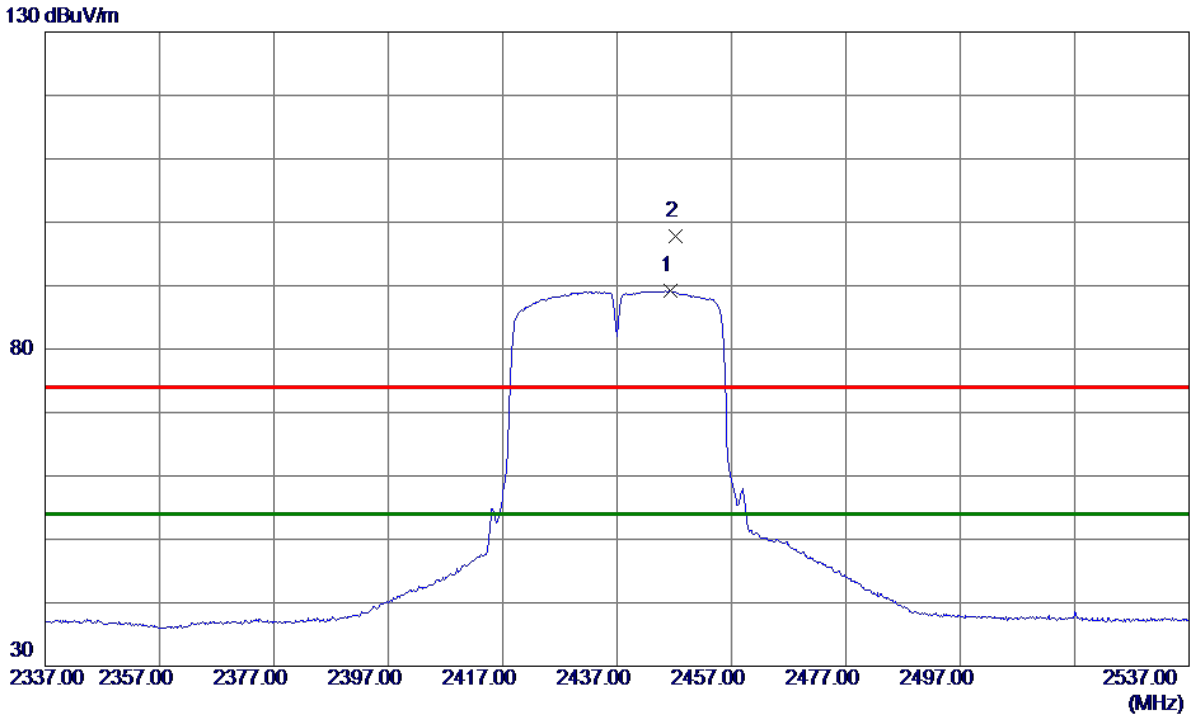

No.	Freq. MHz	Reading Level dBuV/m	Correct Factor dB	Measure ment dBuV/m	Limit dBuV/m	Margin dB	Detector	Comment
1 *	2446.4000	82.51	6.61	89.12	54.00	35.12	AVG	No Limit
2	2447.3000	91.16	6.61	97.77	74.00	23.77	Peak	No Limit

Orthogonal Axis	X
Test Mode:	TX N-40M Mode 2437 MHz

### Horizontal

80 dBuV/m

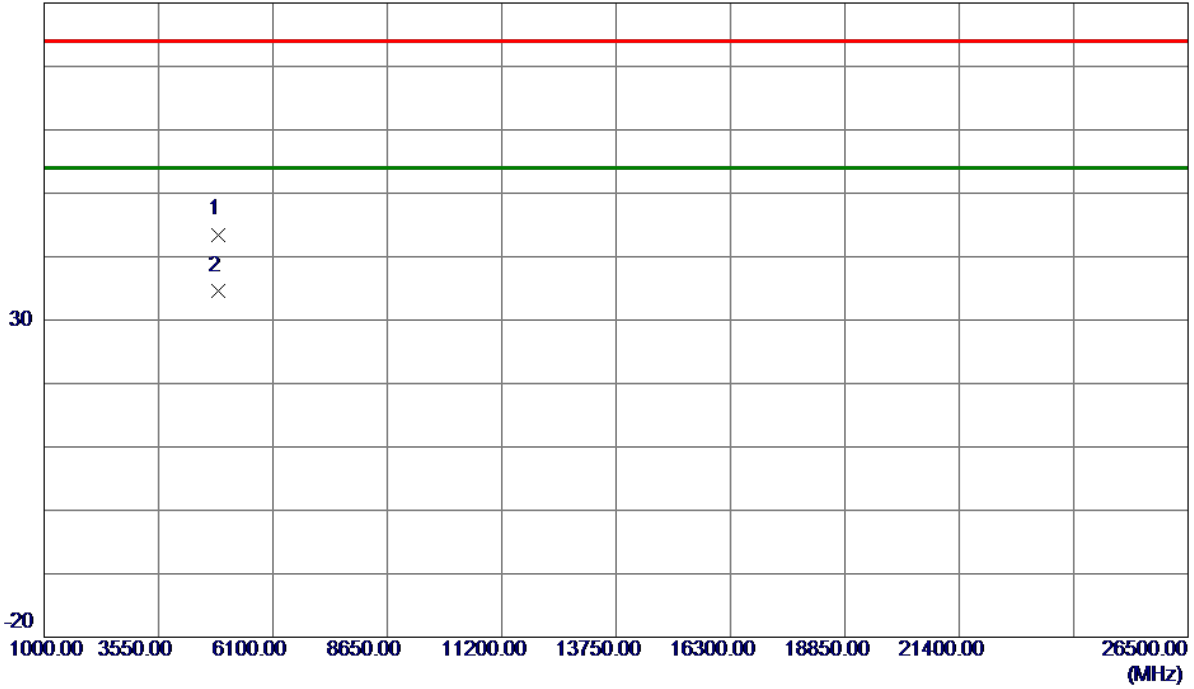

No.	Freq. MHz	Reading Level dBuV/m	Correct Factor dB	Measure ment dBuV/m	Limit dBuV/m	Margin dB	Detector	Comment
1	4871.7750	39.82	3.68	43.50	74.00	-30.50	Peak	
2 *	4873.9500	30.87	3.68	34.55	54.00	-19.45	AVG	

Orthogonal Axis	X
Test Mode:	TX N-40M Mode 2452MHz

**Vertical**

130 dBuV/m

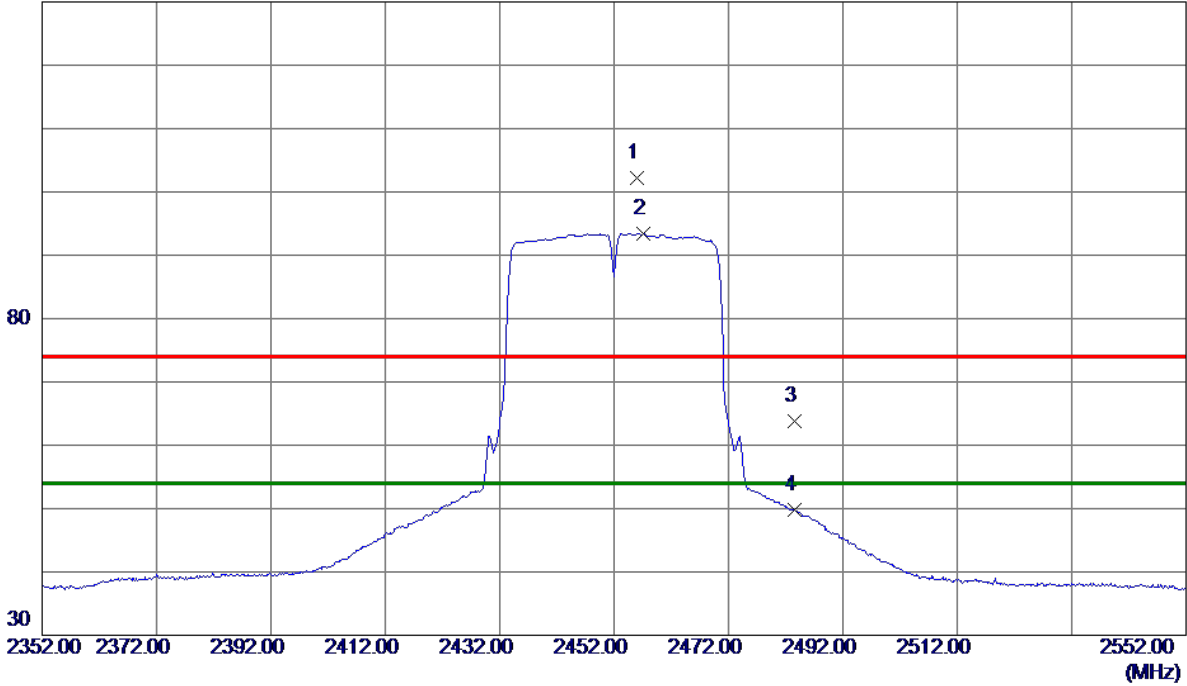

No.	Freq. MHz	Reading Level dBuV/m	Correct Factor dB	Measure ment dBuV/m	Limit dBuV/m	Margin dB	Detector	Comment
1	2456.1000	95.61	6.61	102.22	74.00	28.22	Peak	No Limit
2 *	2457.2000	86.86	6.61	93.47	54.00	39.47	AVG	No Limit
3	2483.5000	57.16	6.61	63.77	74.00	-10.23	Peak	
4	2483.5000	43.19	6.61	49.80	54.00	-4.20	AVG	

Orthogonal Axis	X
Test Mode:	TX N-40M Mode 2452MHz

**Vertical**

80 dBuV/m

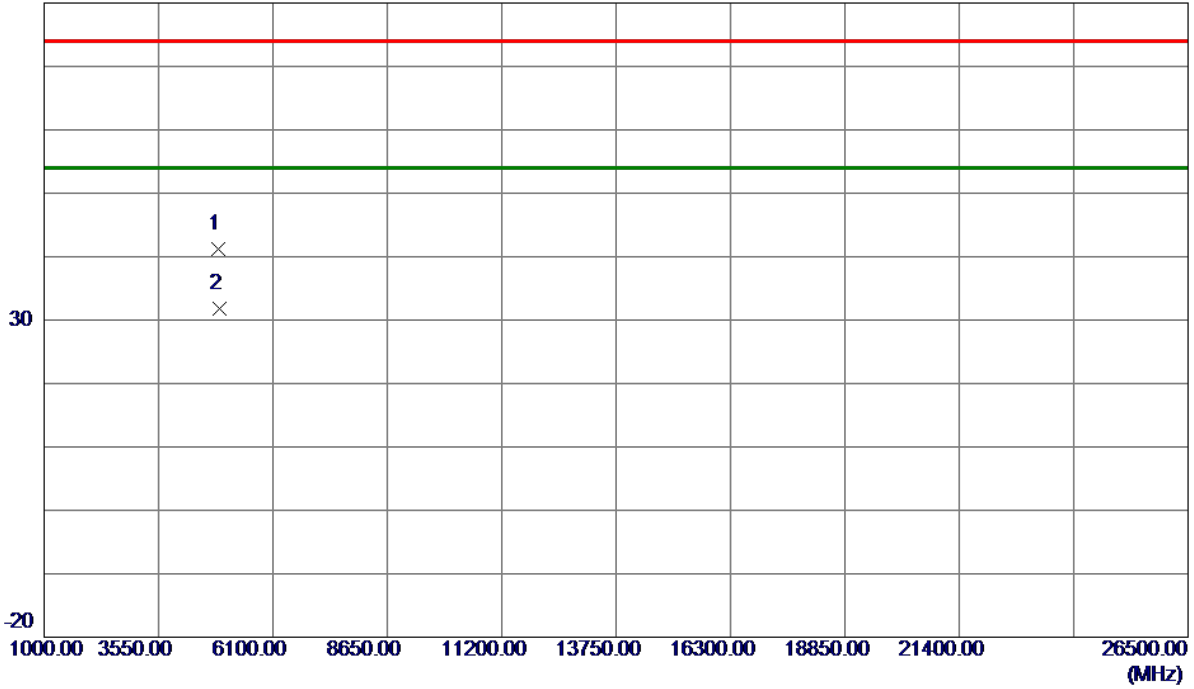

No.	Freq. MHz	Reading Level dBuV/m	Correct Factor dB	Measure ment dBuV/m	Limit dBuV/m	Margin dB	Detector	Comment
1	4893.2250	37.45	3.72	41.17	74.00	-32.83	Peak	
2 *	4903.8250	27.96	3.75	31.71	54.00	-22.29	AVG	

Orthogonal Axis	X
Test Mode:	TX N-40M Mode 2452MHz

### Horizontal

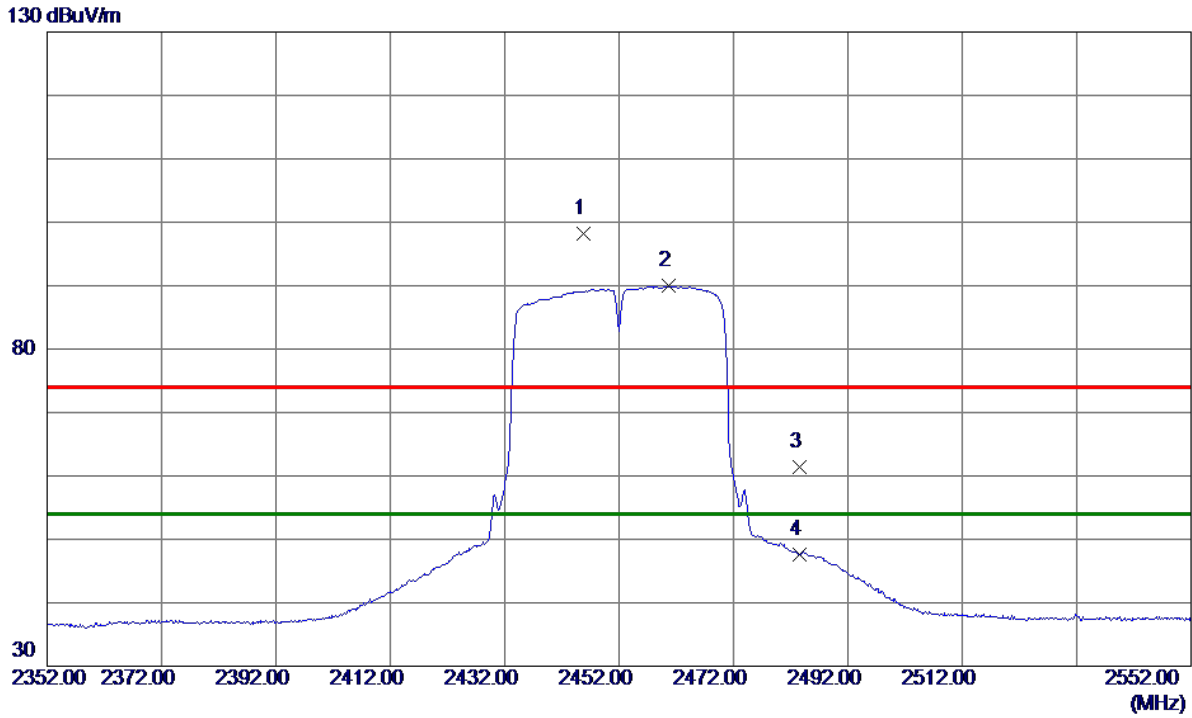

No.	Freq. MHz	Reading Level dBuV/m	Correct Factor dB	Measure ment dBuV/m	Limit dBuV/m	Margin dB	Detector	Comment
1	2445.8000	91.59	6.61	98.20	74.00	24.20	Peak	No Limit
2 *	2460.7000	83.29	6.61	89.90	54.00	35.90	AVG	No Limit
3	2483.5000	54.72	6.61	61.33	74.00	-12.67	Peak	
4	2483.5000	40.93	6.61	47.54	54.00	-6.46	AVG	



Orthogonal Axis	X
Test Mode:	TX N-40M Mode 2452MHz

**Horizontal**

80 dBuV/m

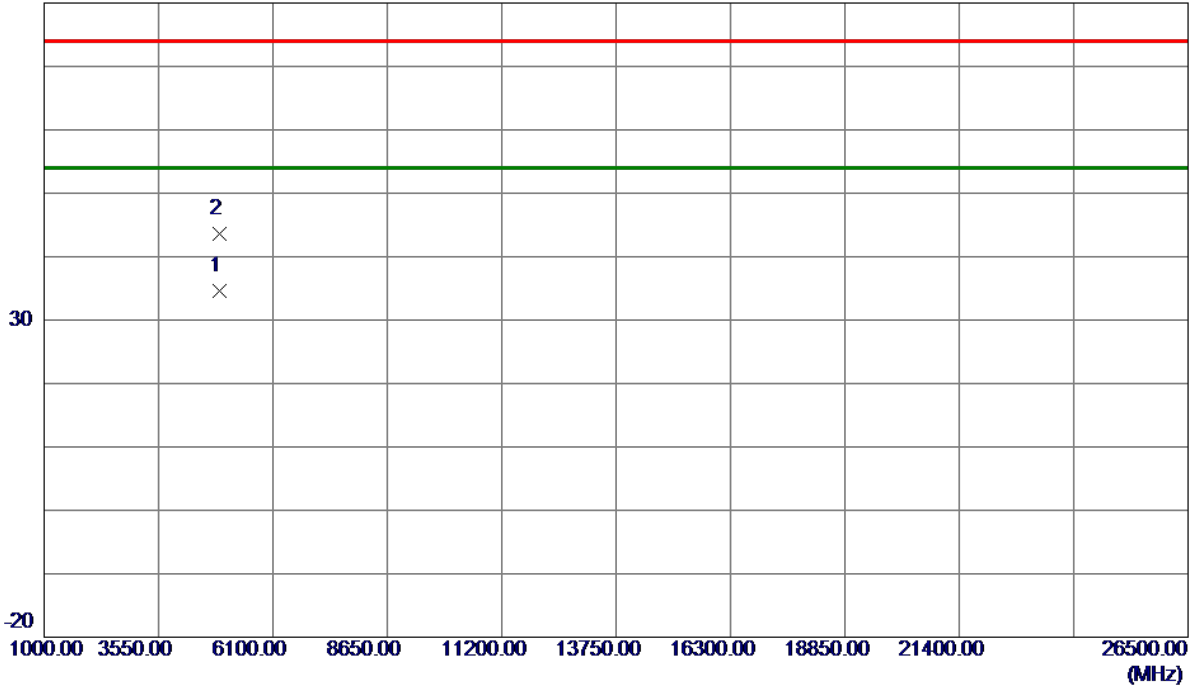

No.	Freq. MHz	Reading Level dBuV/m	Correct Factor dB	Measure ment dBuV/m	Limit dBuV/m	Margin dB	Detector	Comment
1 *	4903.9750	30.86	3.75	34.61	54.00	-19.39	AVG	
2	4921.3000	39.84	3.79	43.63	74.00	-30.37	Peak	

## APPENDIX E - BANDWIDTH

**Test Mode: TX B Mode\_CH01/06/11**

Frequency (MHz)	6 dB Bandwidth (MHz)	99% Occupied BW (MHz)	Min. Limit (kHz)	Test Result
2412	10.08	15.64	500	Complies
2437	10.06	15.68	500	Complies
2462	10.06	15.68	500	Complies

**TX CH01**

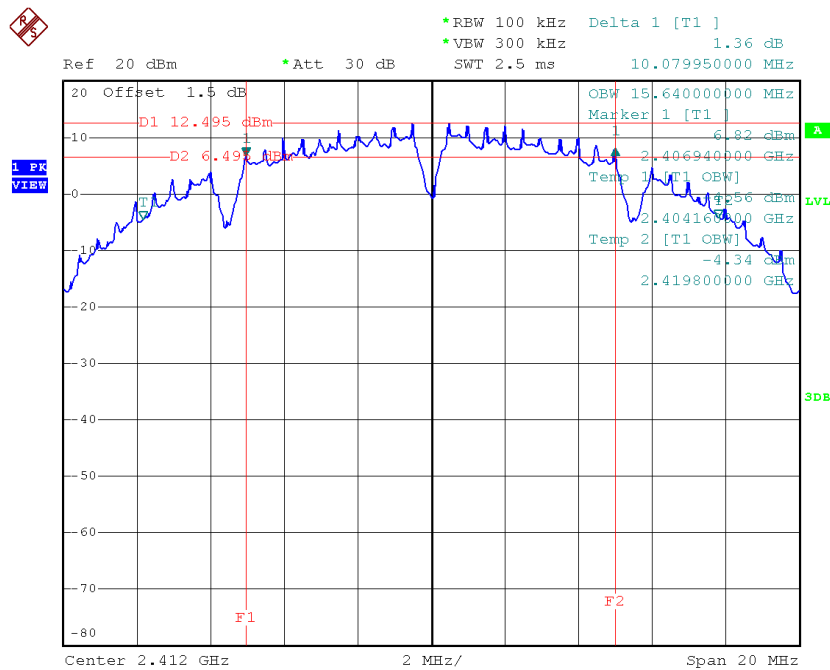

Date: 23.NOV.2018 14:39:19

**TX CH06**

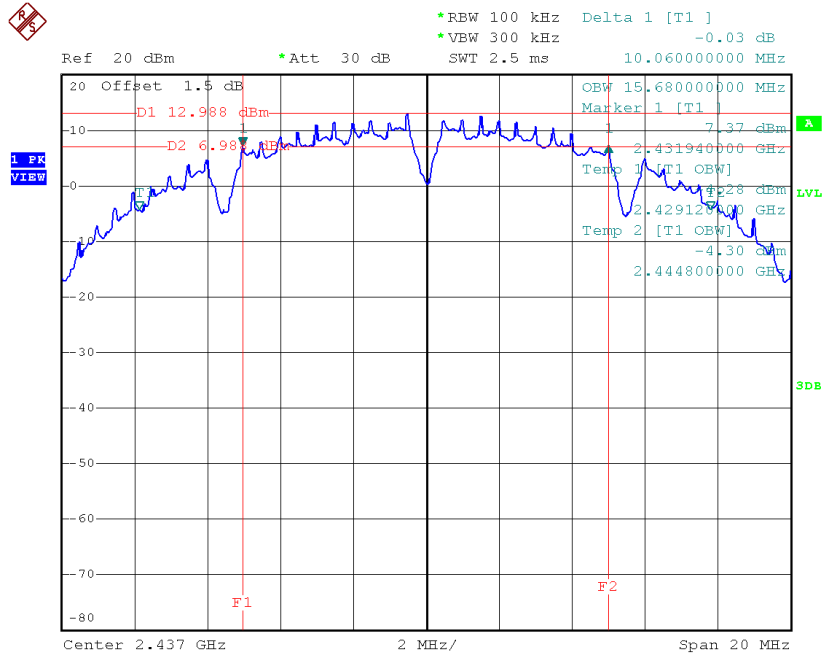

Date: 23.NOV.2018 14:43:45

**TX CH11**

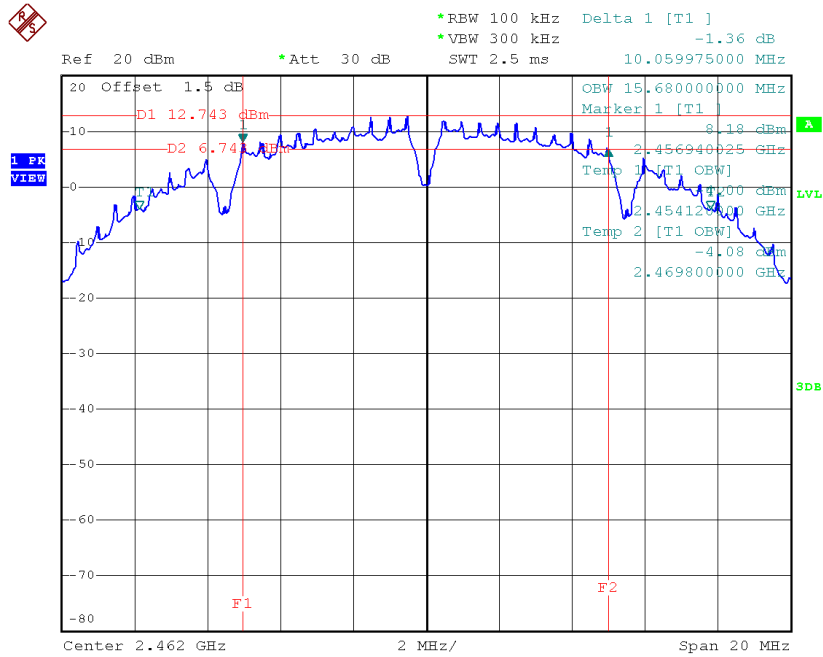

Date: 23.NOV.2018 14:45:36

**Test Mode: TX G Mode\_CH01/06/11**

Frequency (MHz)	6 dB Bandwidth (MHz)	99% Occupied BW (MHz)	Min. Limit (kHz)	Test Result
2412	16.39	16.56	500	Complies
2437	16.42	16.56	500	Complies
2462	16.43	16.52	500	Complies

**TX CH01**

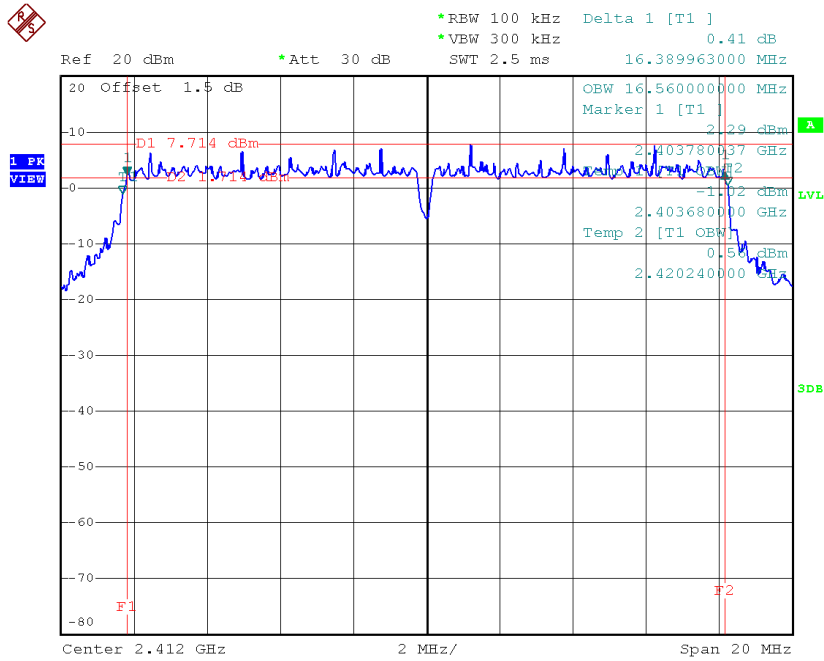

Date: 23.NOV.2018 14:59:49

### TX CH06

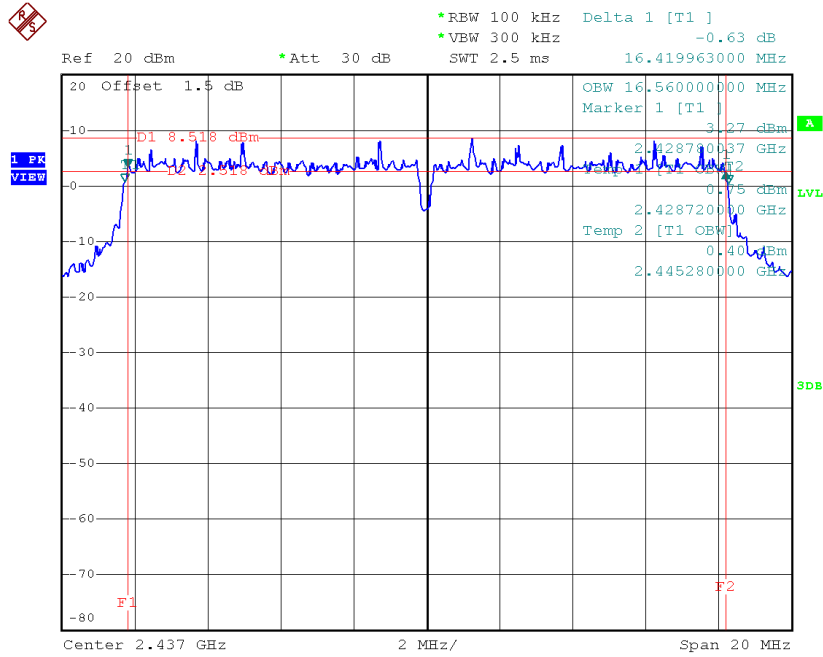

Date: 23.NOV.2018 15:05:03

### TX CH11

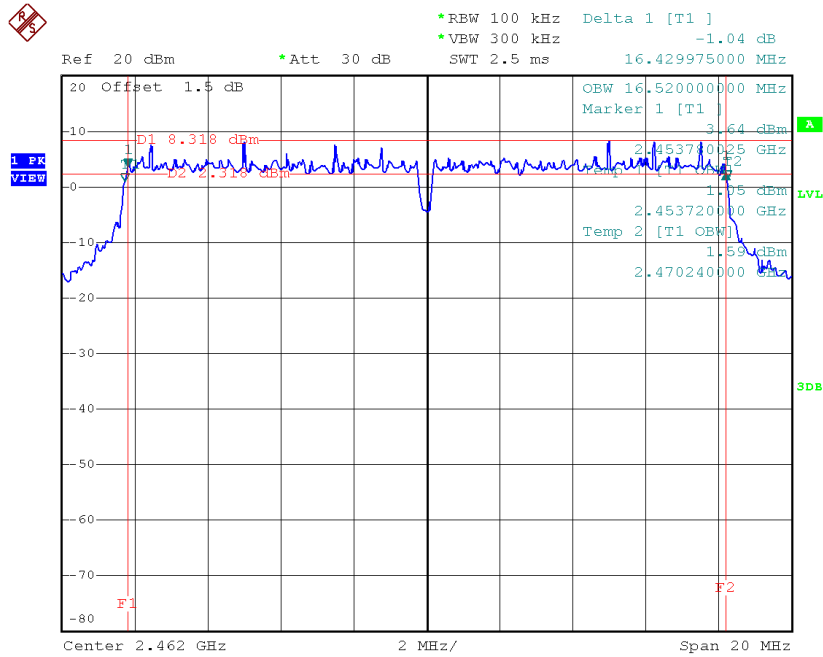

Date: 23.NOV.2018 15:06:31

**Test Mode: TX N-20MHz Mode\_CH01/06/11**

Frequency (MHz)	6 dB Bandwidth (MHz)	99% Occupied BW (MHz)	Min. Limit (kHz)	Test Result
2412	17.62	17.72	500	Complies
2437	17.66	17.72	500	Complies
2462	17.66	17.72	500	Complies

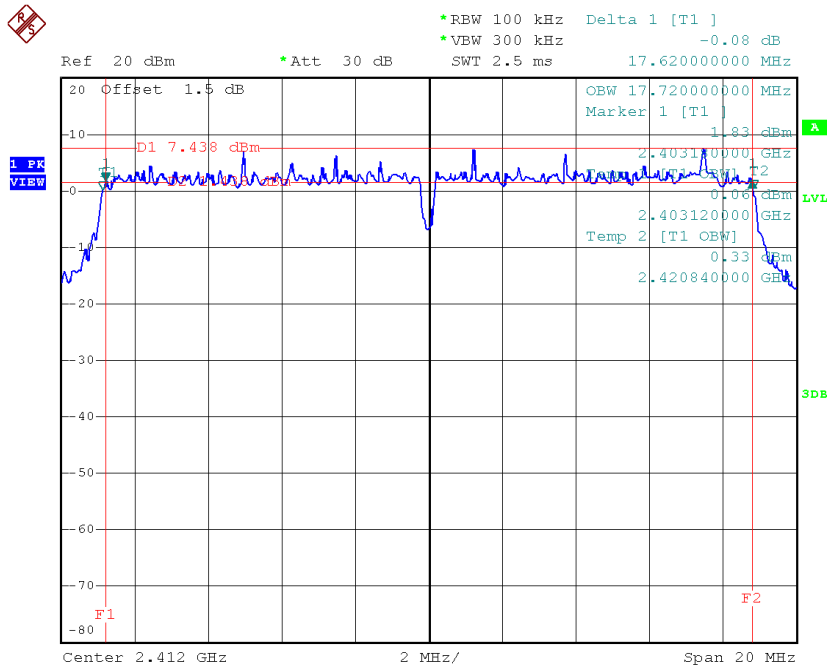
**TX CH01**

Date: 23.NOV.2018 15:08:52

**TX CH06**

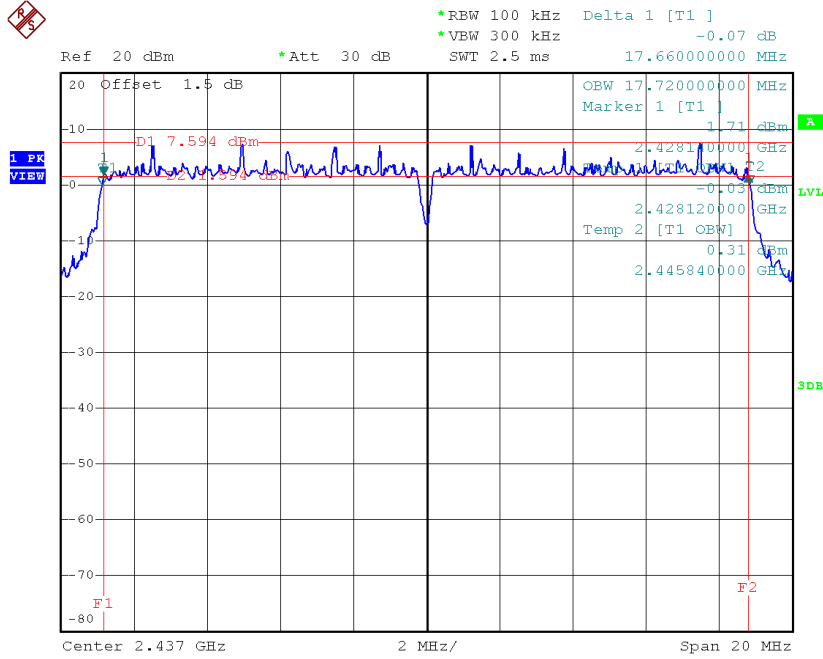

Date: 23.NOV.2018 15:10:09

**TX CH11**



Date: 23.NOV.2018 15:11:30



**Test Mode: TX N-40MHz Mode\_CH03/06/09**

Frequency (MHz)	6 dB Bandwidth (MHz)	99% Occupied BW (MHz)	Min. Limit (kHz)	Test Result
2422	35.19	35.92	500	Complies
2437	34.56	36.00	500	Complies
2452	35.44	36.00	500	Complies

**TX CH03**

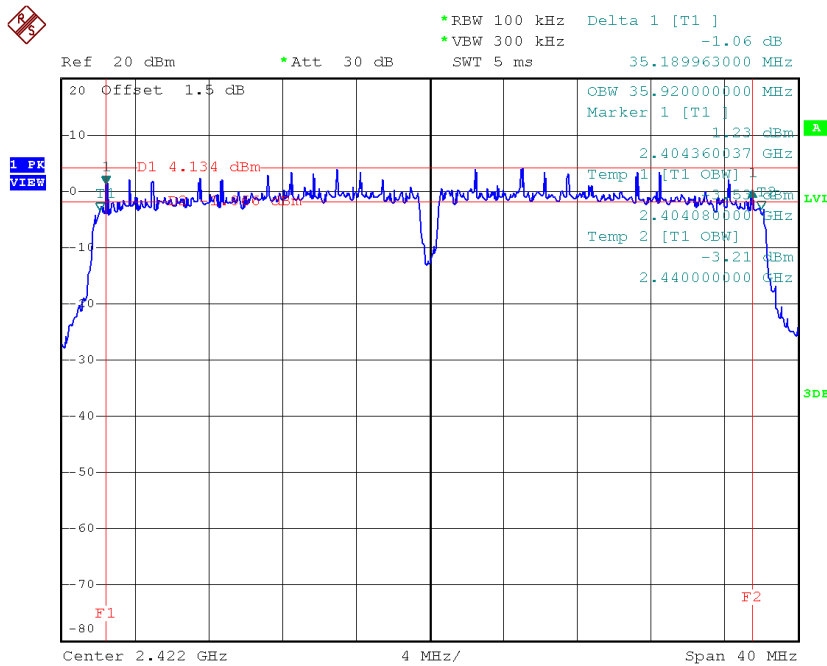

Date: 23.NOV.2018 15:13:14

**TX CH06**

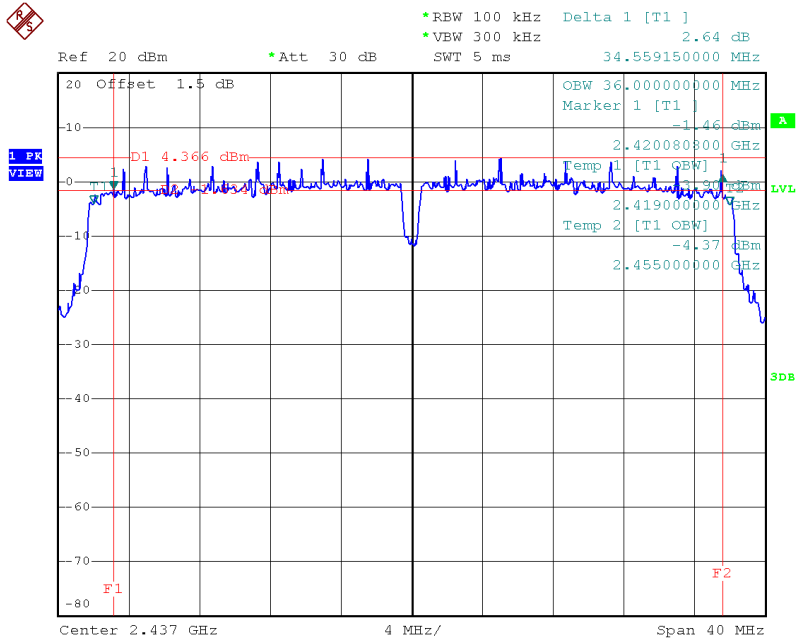

Date: 23.NOV.2018 15:14:37

**TX CH09**

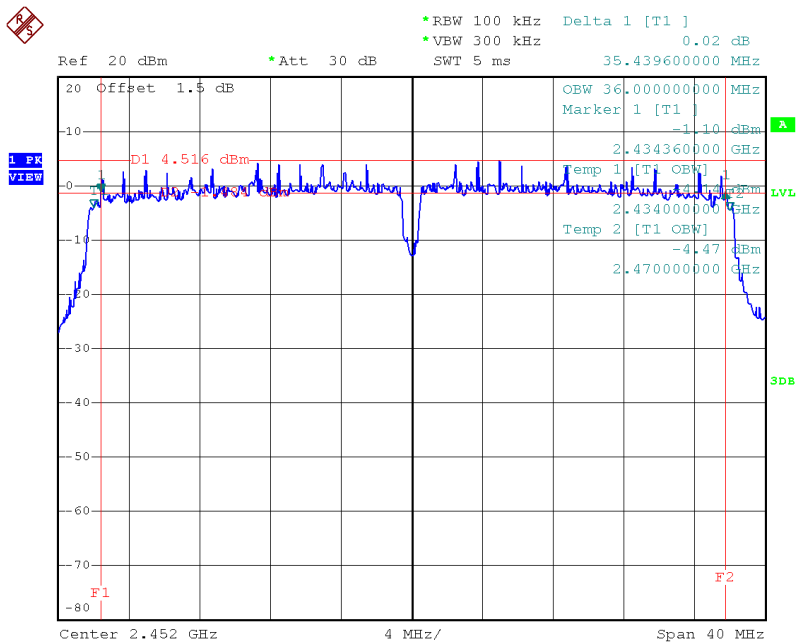

Date: 23.NOV.2018 15:15:55

## APPENDIX F - MAXIMUM OUTPUT POWER

Test Mode: TX B Mode_CH01/06/11					
Frequency (MHz)	Output Power (dBm)	Output Power (W)	Max. Limit (dBm)	Max. Limit (W)	Result
2412	24.11	0.26	30.00	1.00	Complies
2437	24.96	0.31	30.00	1.00	Complies
2462	24.38	0.27	30.00	1.00	Complies

Test Mode: TX G Mode_CH01/06/11					
Frequency (MHz)	Output Power (dBm)	Output Power (W)	Max. Limit (dBm)	Max. Limit (W)	Result
2412	27.06	0.51	30.00	1.00	Complies
2437	27.33	0.54	30.00	1.00	Complies
2462	26.23	0.42	30.00	1.00	Complies

Test Mode: TX N20 Mode_CH01/06/11					
Frequency (MHz)	Output Power (dBm)	Output Power (W)	Max. Limit (dBm)	Max. Limit (W)	Result
2412	26.49	0.45	30.00	1.00	Complies
2437	27.34	0.54	30.00	1.00	Complies
2462	25.84	0.38	30.00	1.00	Complies

Test Mode: TX N40 Mode_CH03/06/09					
Frequency (MHz)	Output Power (dBm)	Output Power (W)	Max. Limit (dBm)	Max. Limit (W)	Result
2422	25.63	0.37	30.00	1.00	Complies
2437	26.87	0.49	30.00	1.00	Complies
2452	25.19	0.33	30.00	1.00	Complies

# APPENDIX G - ANTENNA CONDUCTED SPURIOUS EMISSION

**Test Mode: TX B Mode**

**TX B mode CH01**

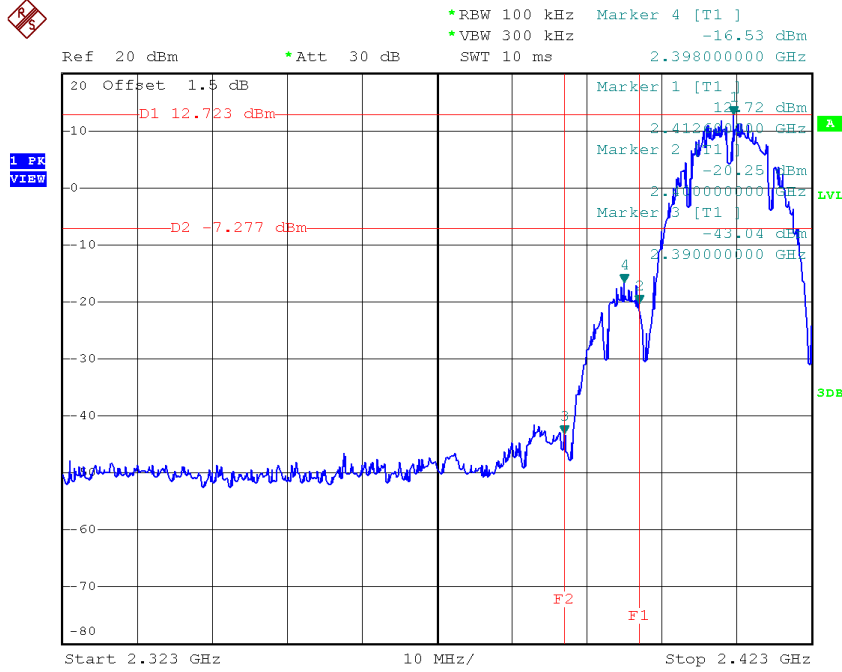

Date: 23.NOV.2018 14:39:27

**TX B mode CH11**

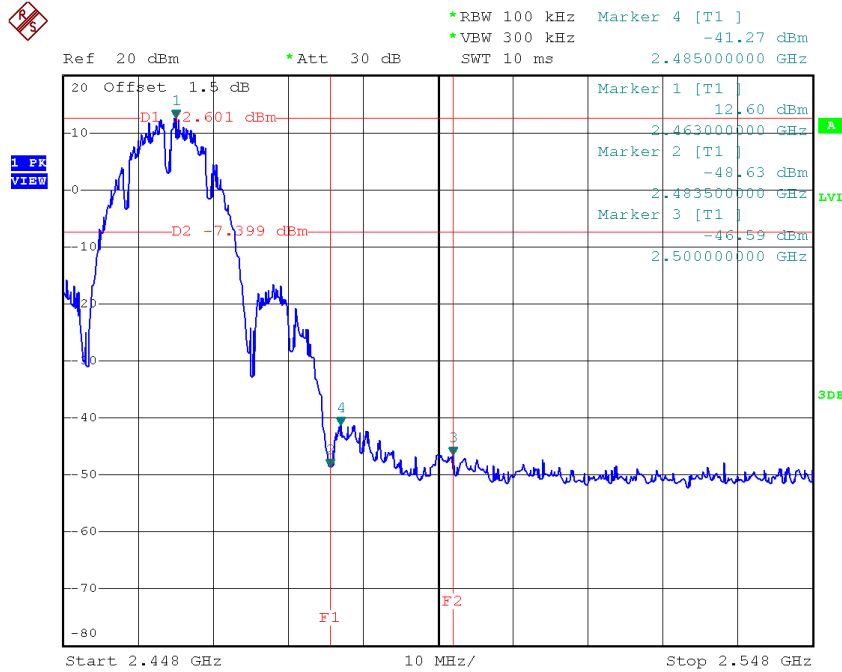

Date: 23.NOV.2018 14:45:44

### TX B mode CH01 (10 Harmonic of the frequency)

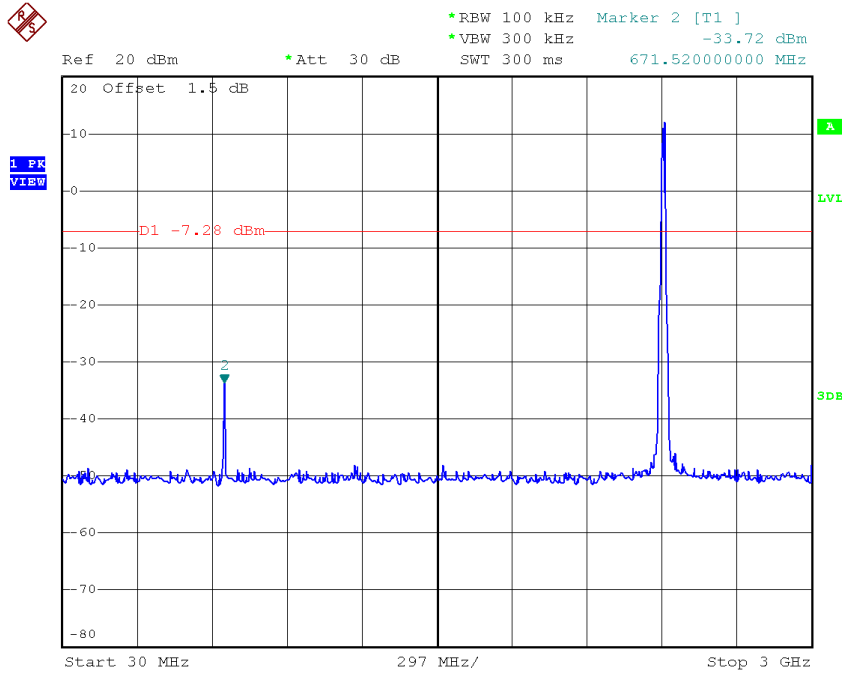

Date: 23.NOV.2018 14:39:41

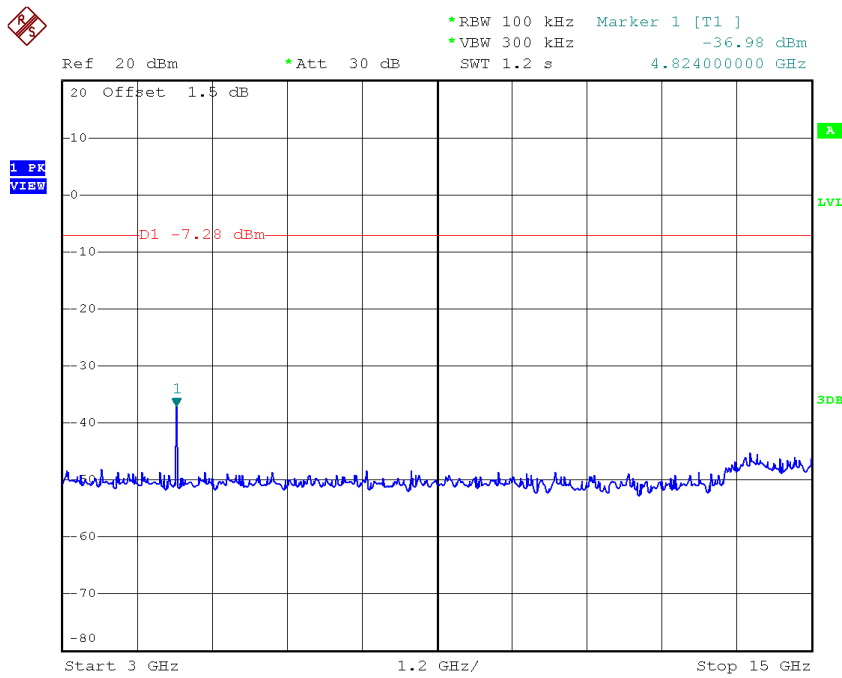

Date: 23.NOV.2018 14:39:50

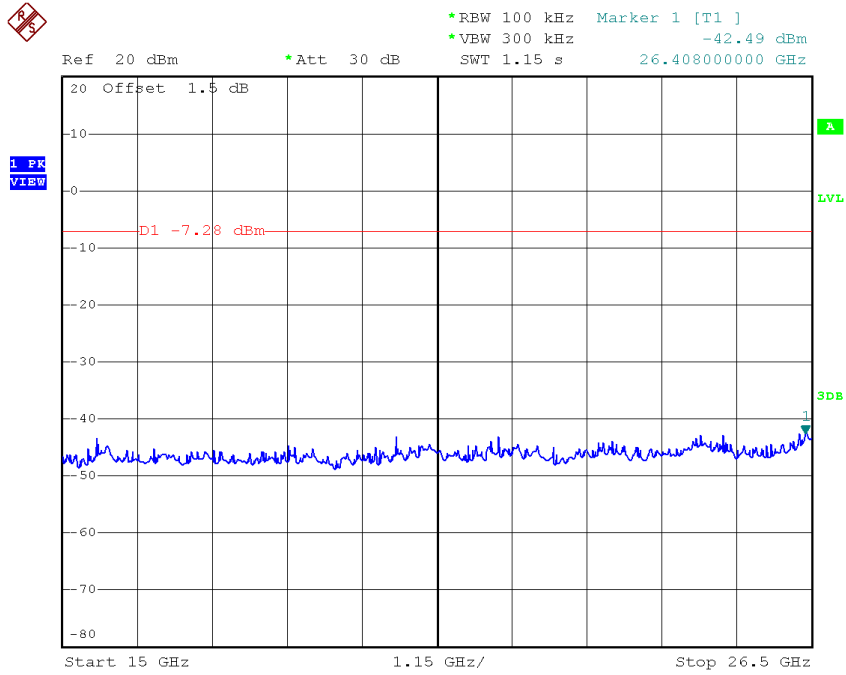

Date: 23.NOV.2018 14:39:58

### TX B mode CH06 (10 Harmonic of the frequency)

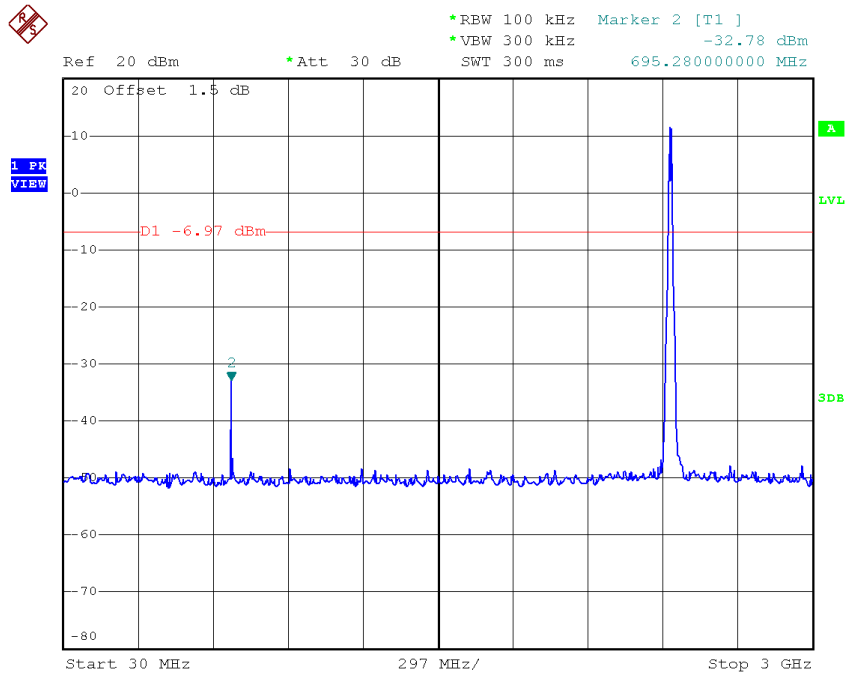

Date: 23.NOV.2018 14:44:07



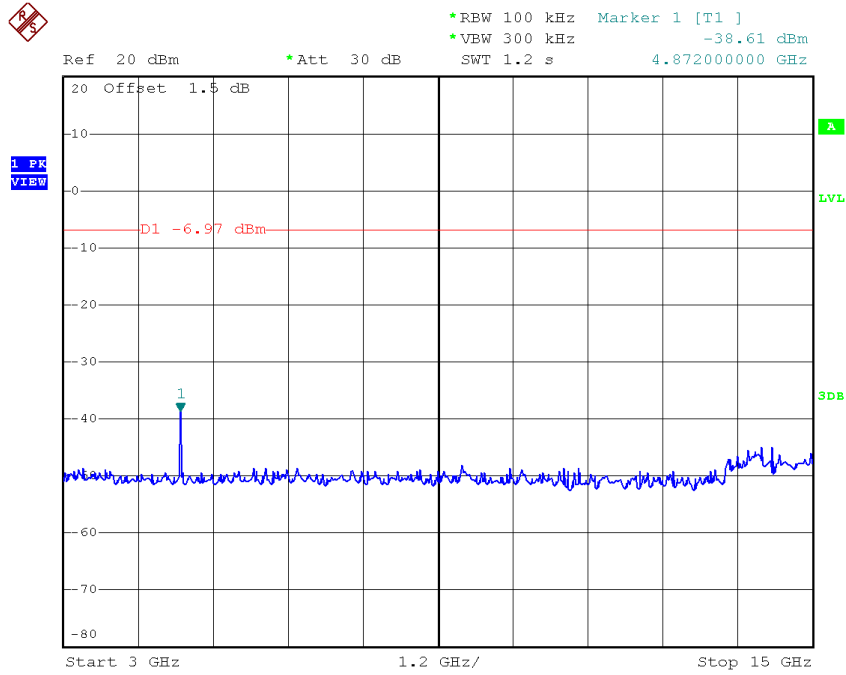

Date: 23.NOV.2018 14:44:15

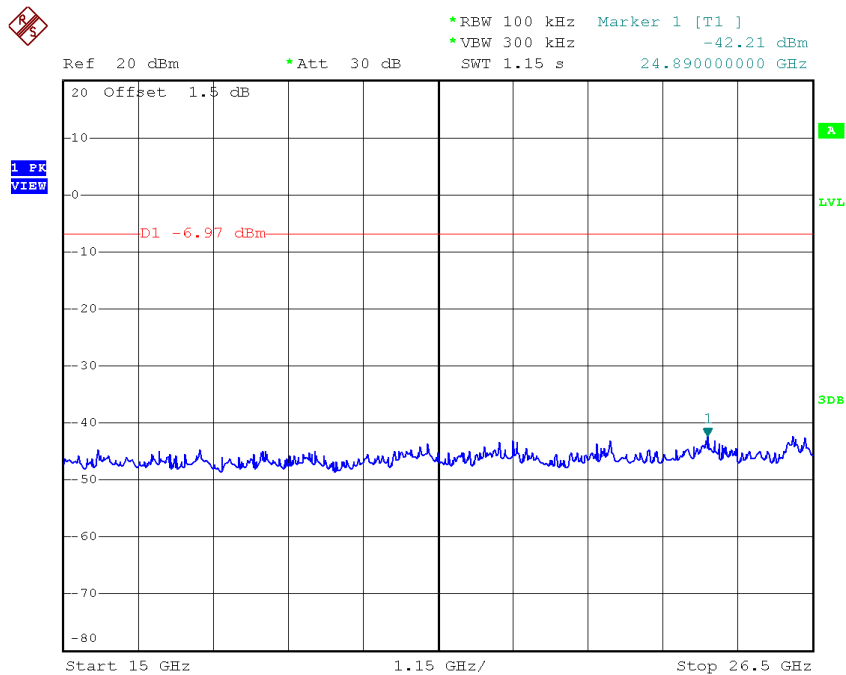

Date: 23.NOV.2018 14:44:24

### TX B mode CH11 (10 Harmonic of the frequency)

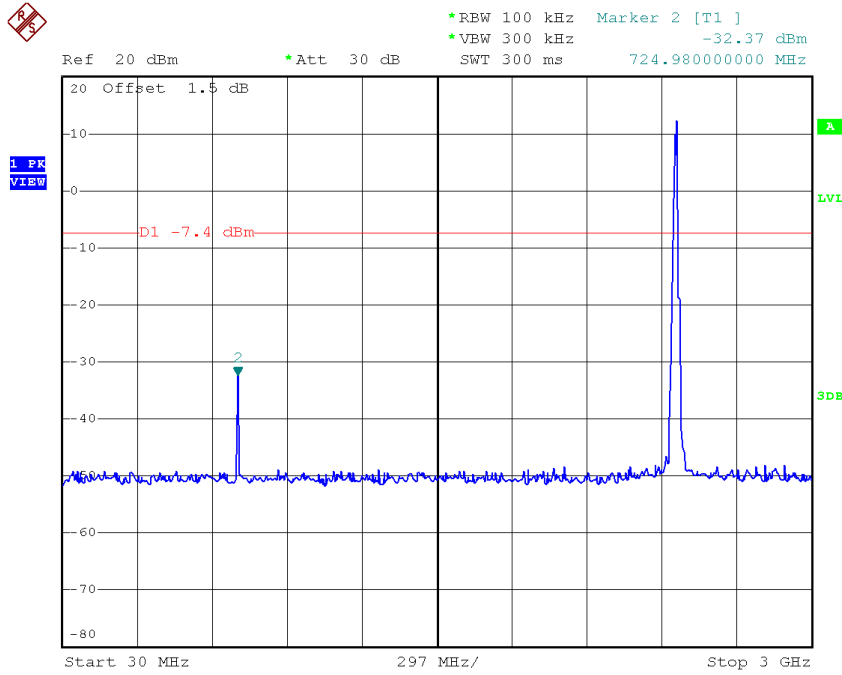

Date: 23.NOV.2018 14:45:58

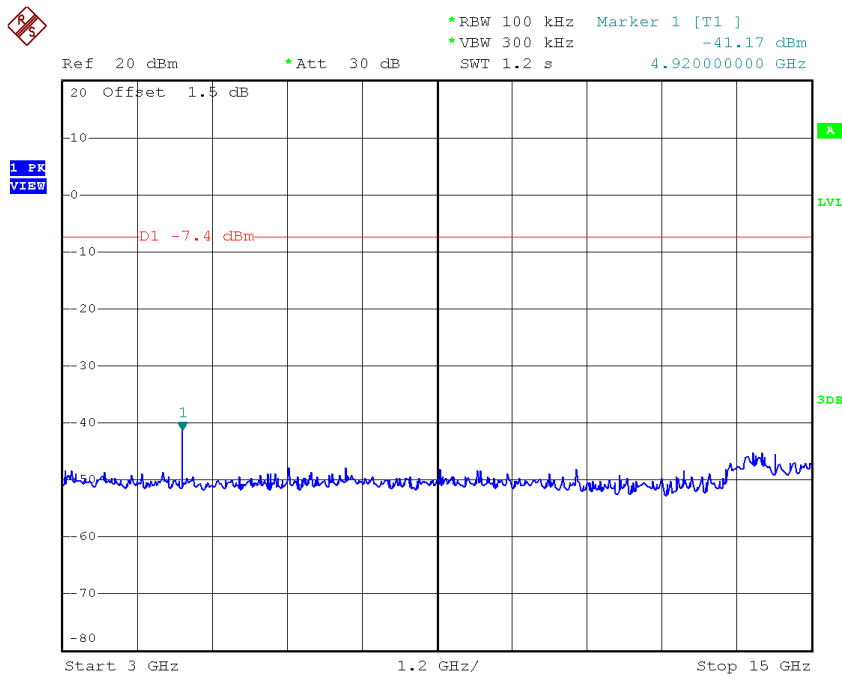

Date: 23.NOV.2018 14:46:06

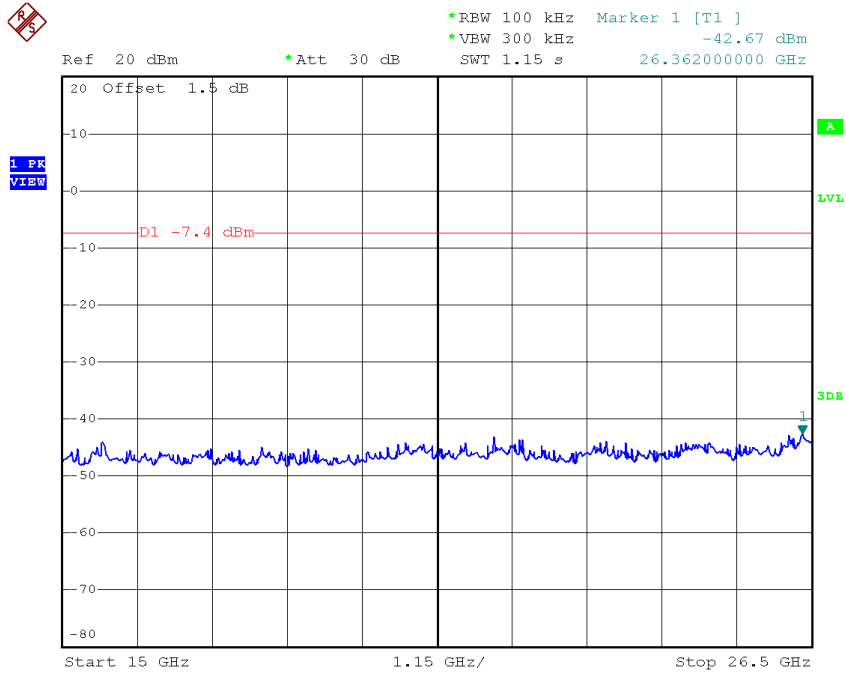

Date: 23.NOV.2018 14:46:15

Test Mode: TX G Mode

### TX G mode CH01

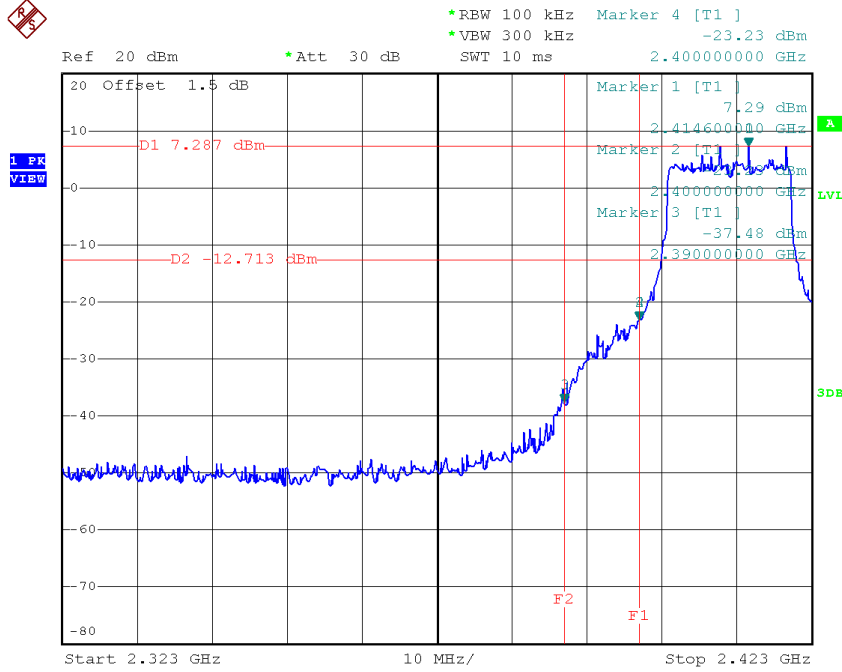

Date: 23.NOV.2018 14:59:58

### TX G mode CH11

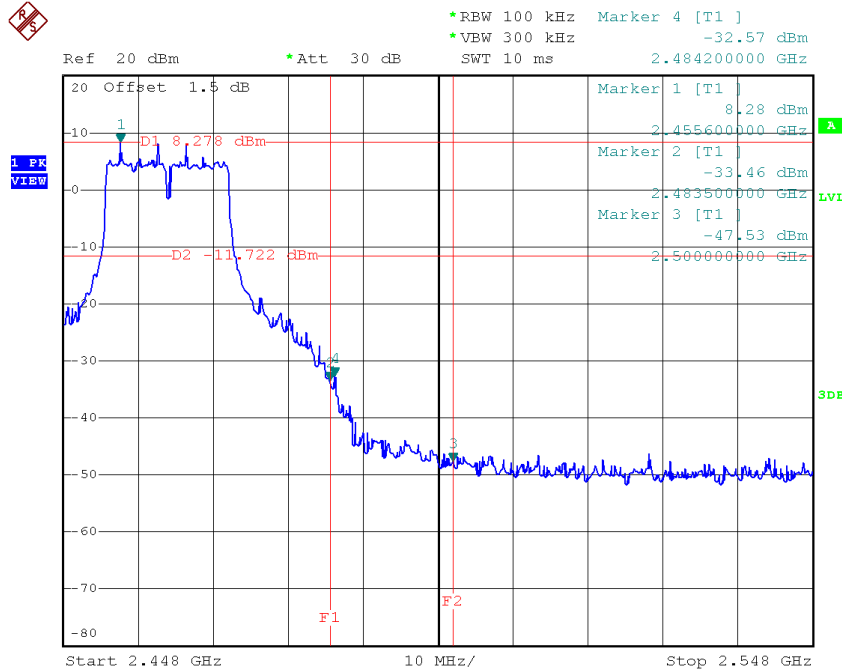

Date: 23.NOV.2018 15:06:40

### TX G mode CH01 (10 Harmonic of the frequency)

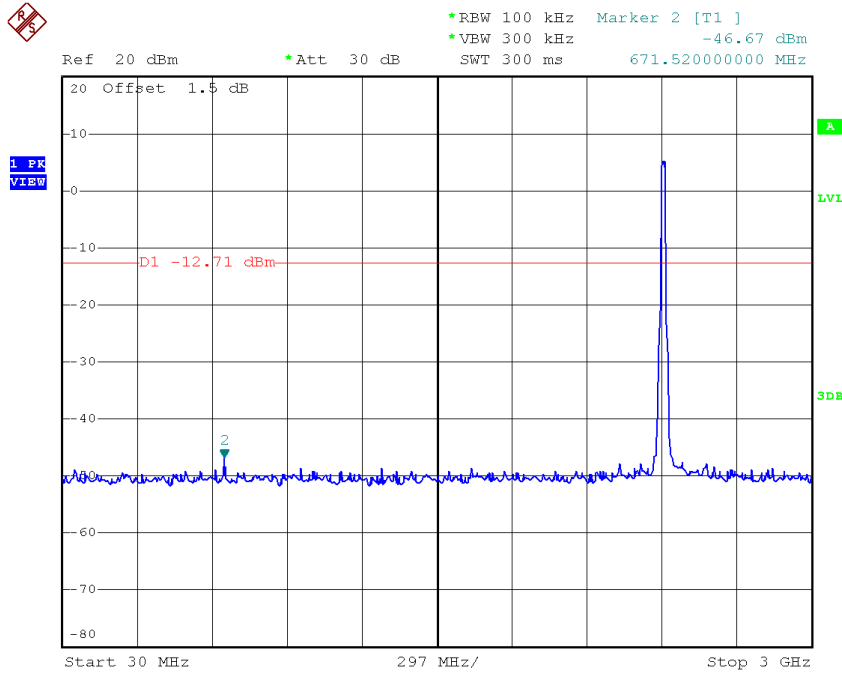

Date: 23.NOV.2018 15:00:12

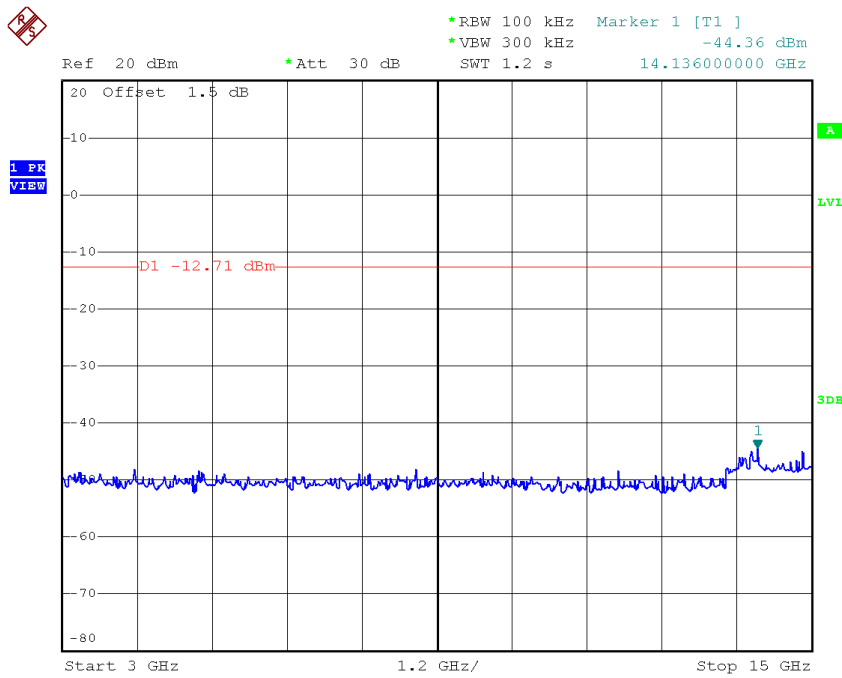

Date: 23.NOV.2018 15:00:20



Date: 23.NOV.2018 15:00:29

**TX G mode CH06 (10 Harmonic of the frequency)**

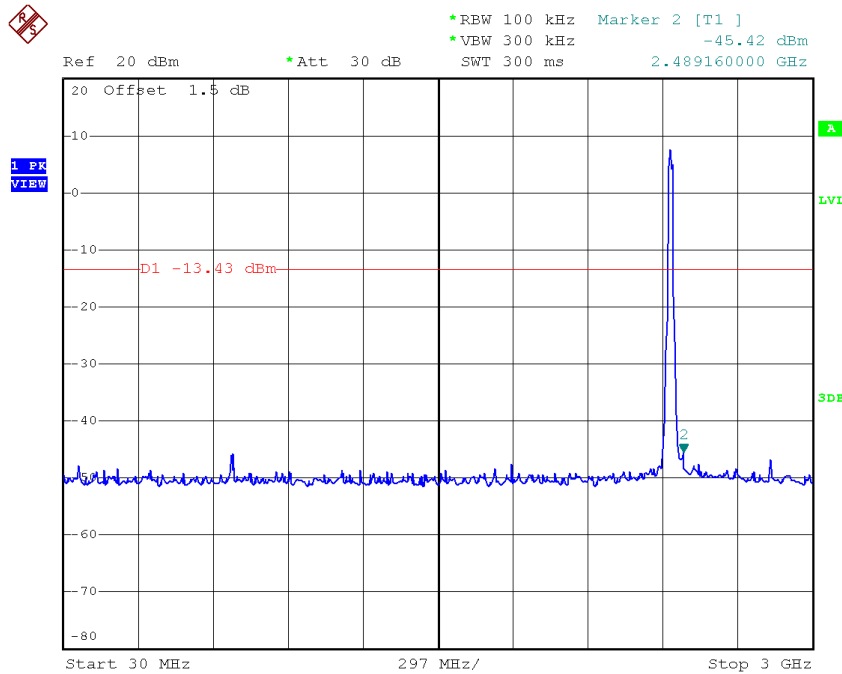

Date: 23.NOV.2018 15:05:25

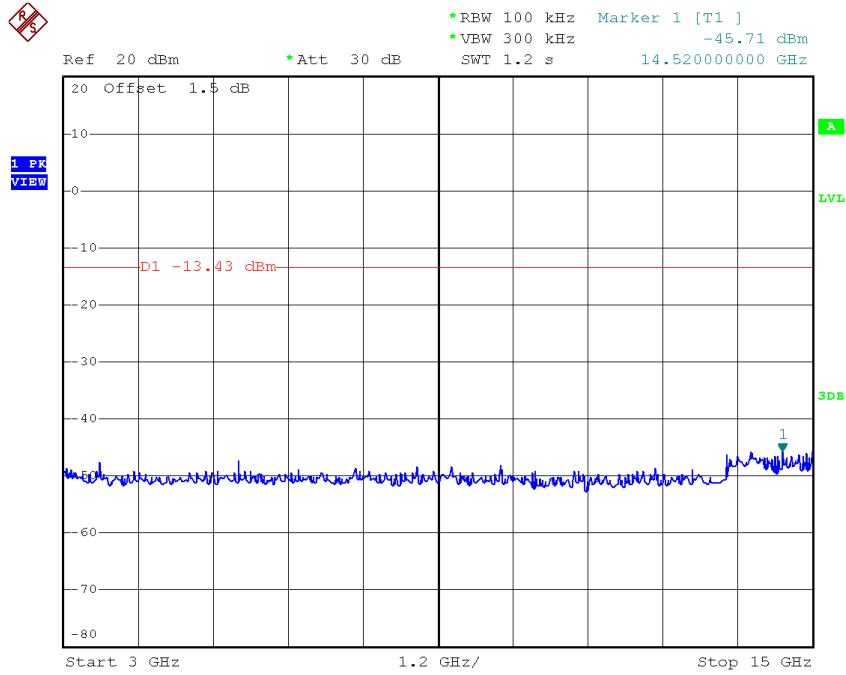

Date: 23.NOV.2018 15:05:34

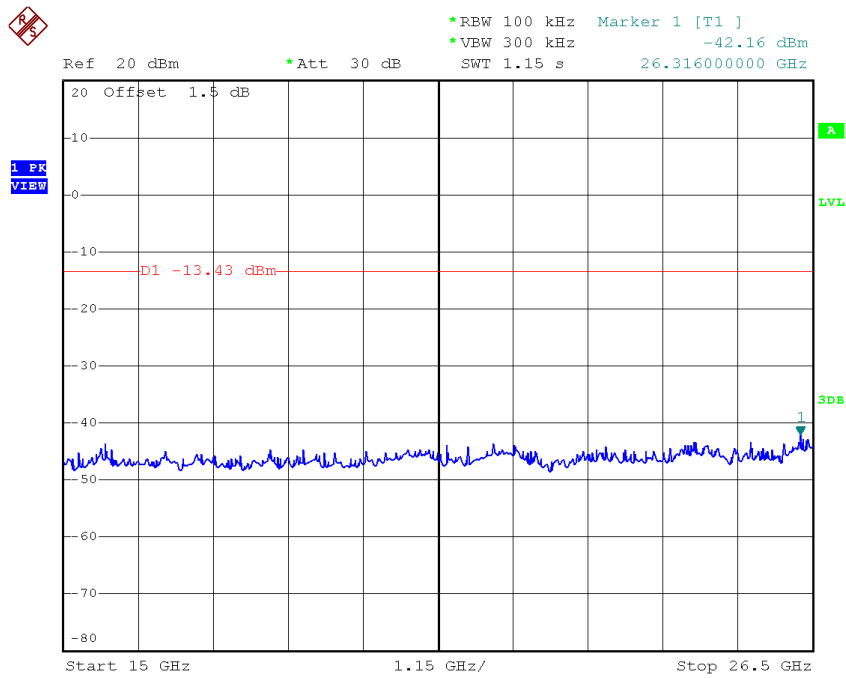

Date: 23.NOV.2018 15:05:42

### TX G mode CH11 (10 Harmonic of the frequency)

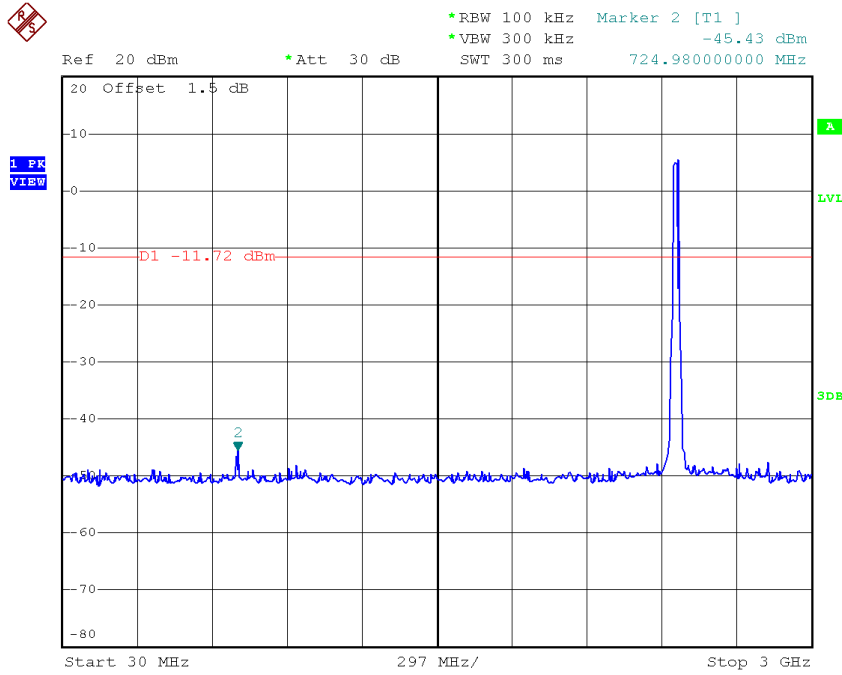

Date: 23.NOV.2018 15:06:54

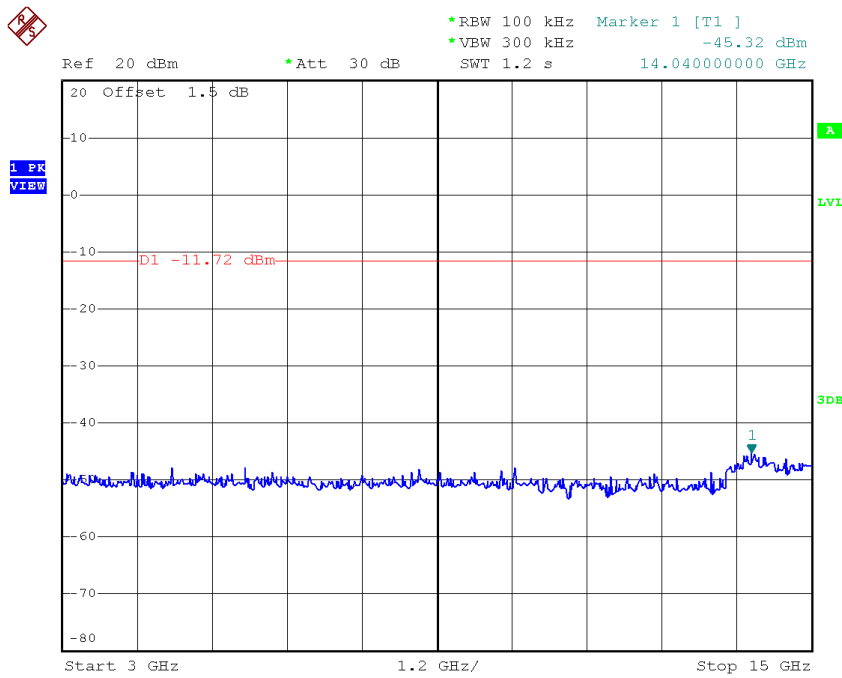

Date: 23.NOV.2018 15:07:02



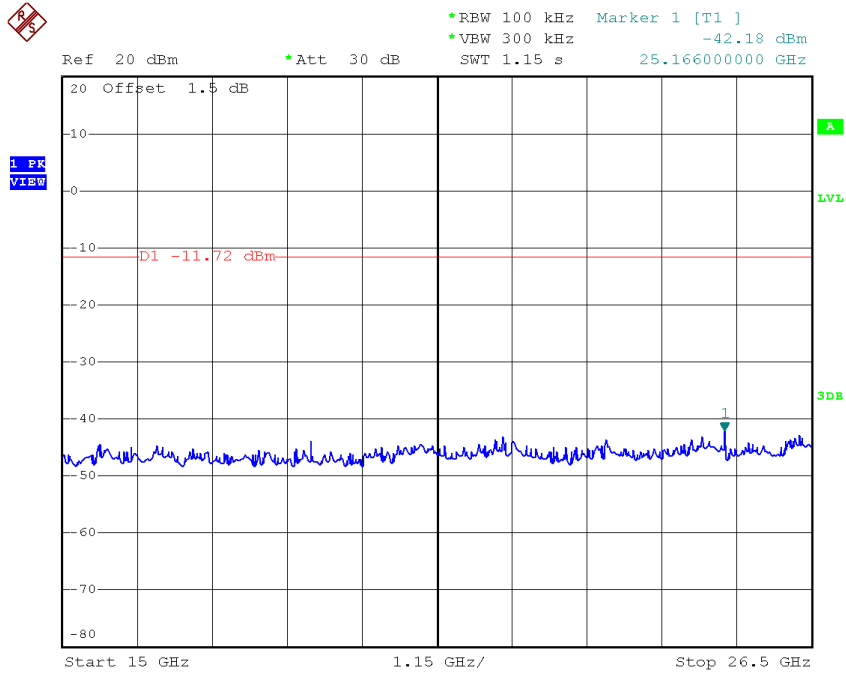

Date: 23.NOV.2018 15:07:11

**Test Mode: TX N-20M Mode**

**TX HT20 mode CH01**

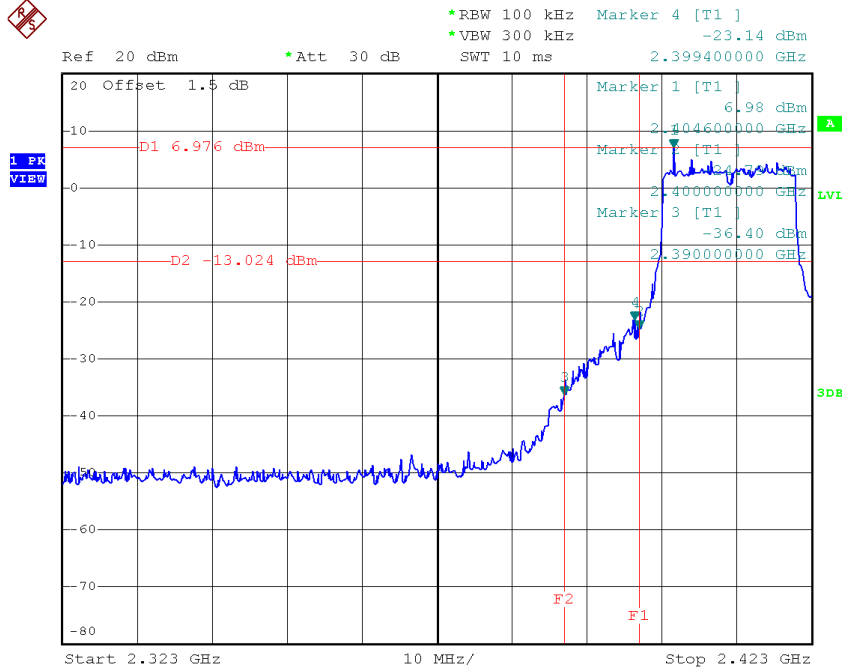

Date: 23.NOV.2018 15:09:00

**TX HT20 mode CH11**

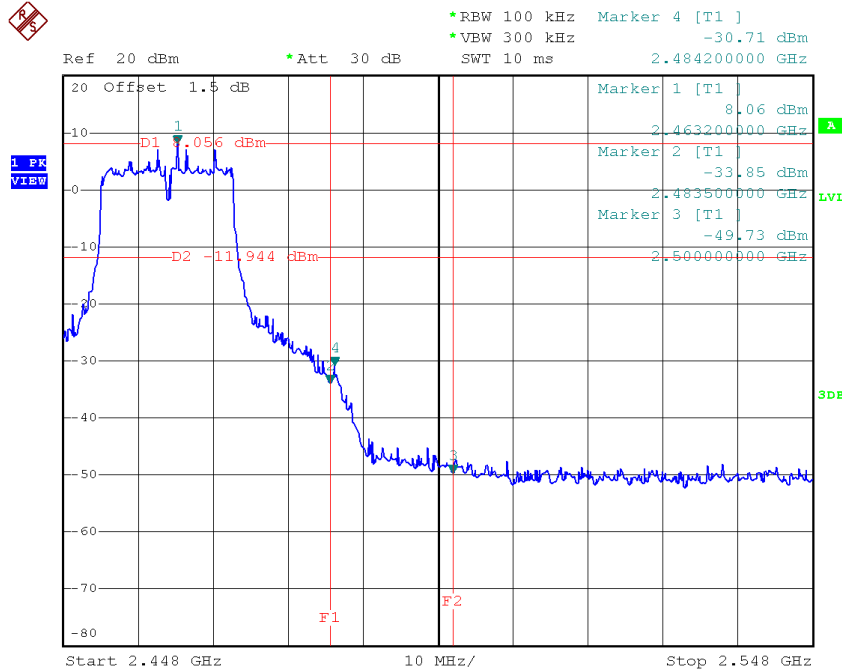

Date: 23.NOV.2018 15:11:38

### TX HT20 mode CH01 (10 Harmonic of the frequency)

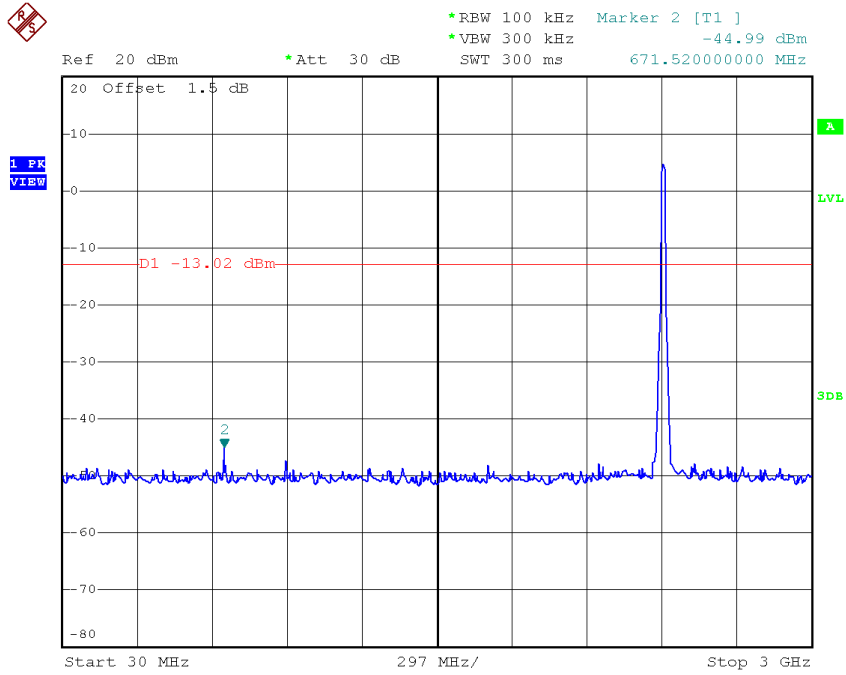

Date: 23.NOV.2018 15:09:14

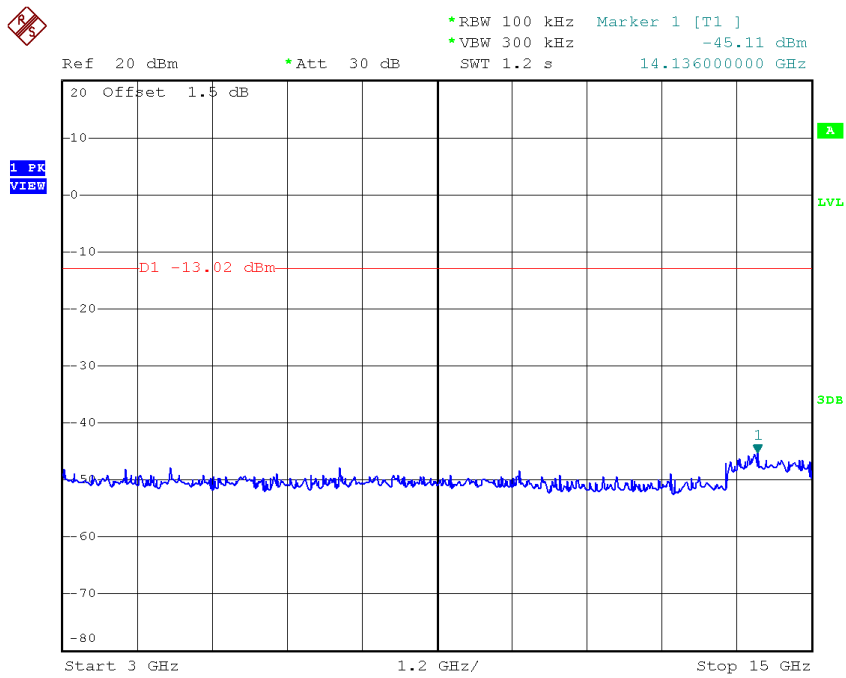

Date: 23.NOV.2018 15:09:22

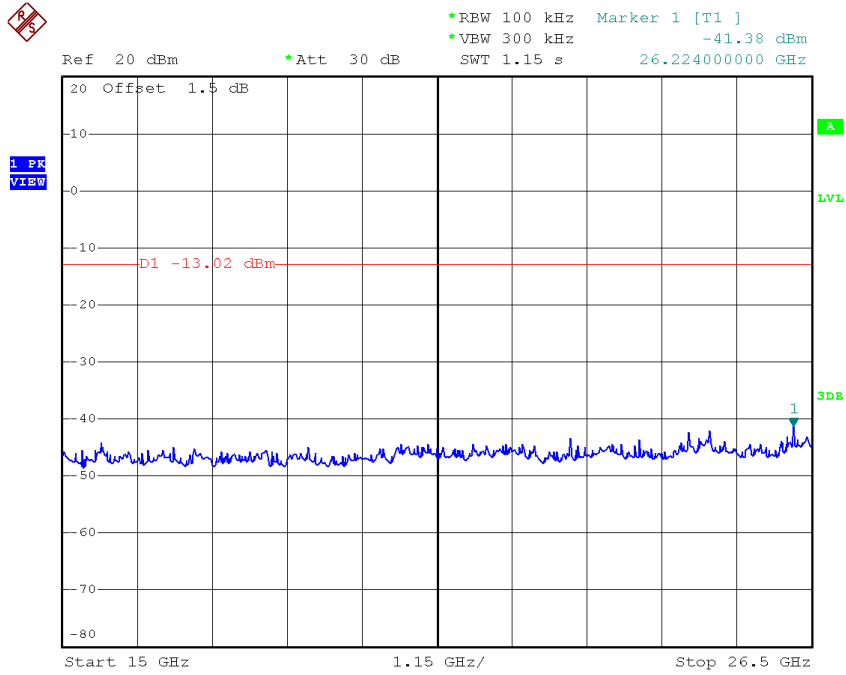

Date: 23.NOV.2018 15:09:31

**TX HT20 mode CH06 (10 Harmonic of the frequency)**

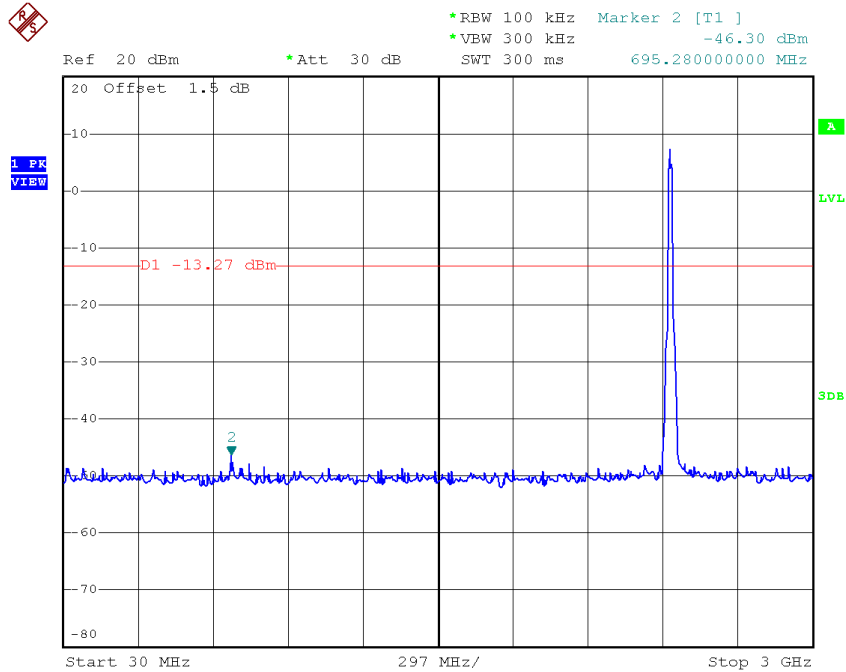

Date: 23.NOV.2018 15:10:31

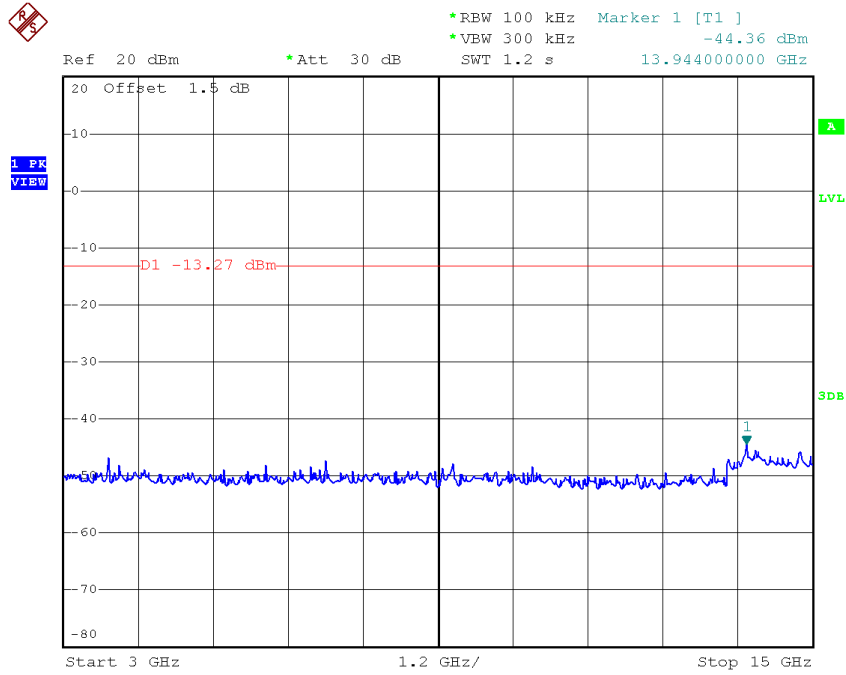

Date: 23.NOV.2018 15:10:40

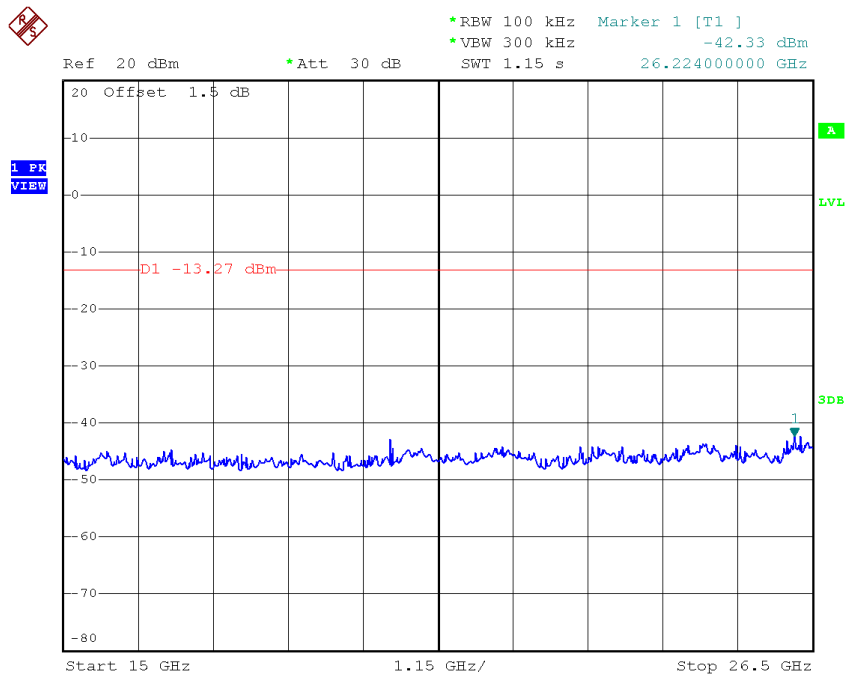

Date: 23.NOV.2018 15:10:48

### TX HT20 mode CH11 (10 Harmonic of the frequency)

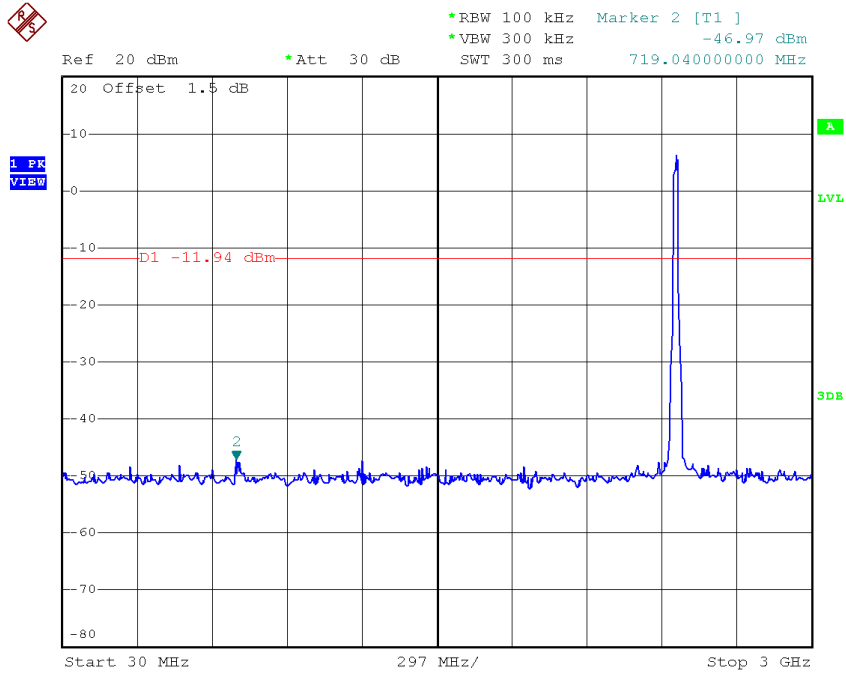

Date: 23.NOV.2018 15:11:52

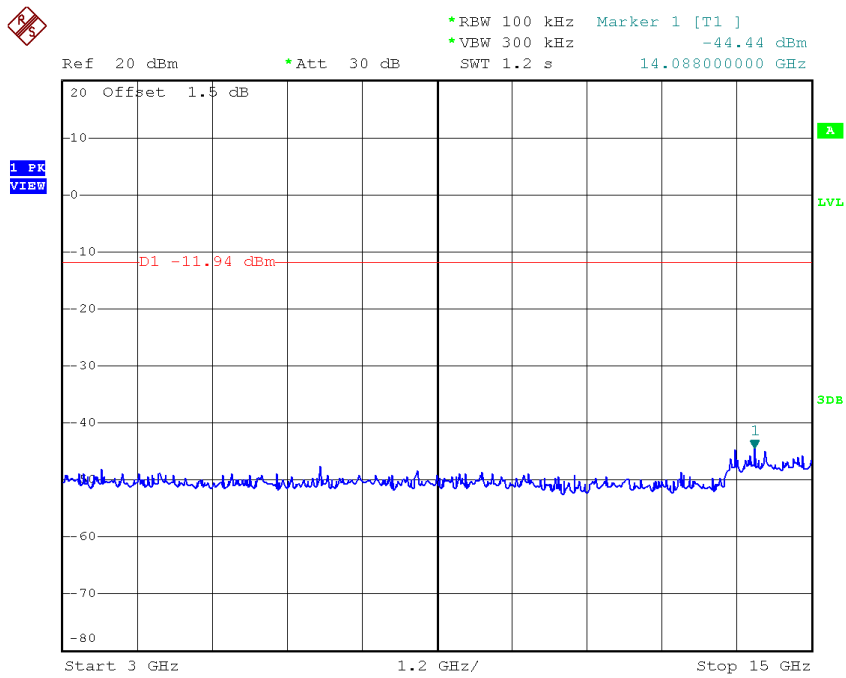

Date: 23.NOV.2018 15:12:01

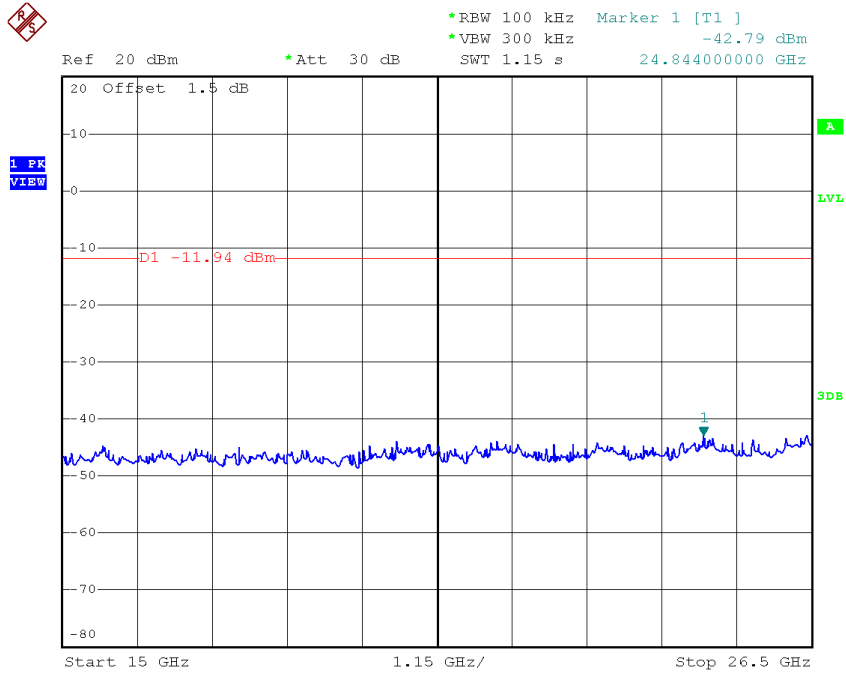

Date: 23.NOV.2018 15:12:09

**Test Mode: TX N-40M Mode**

**TX HT40 mode CH03**

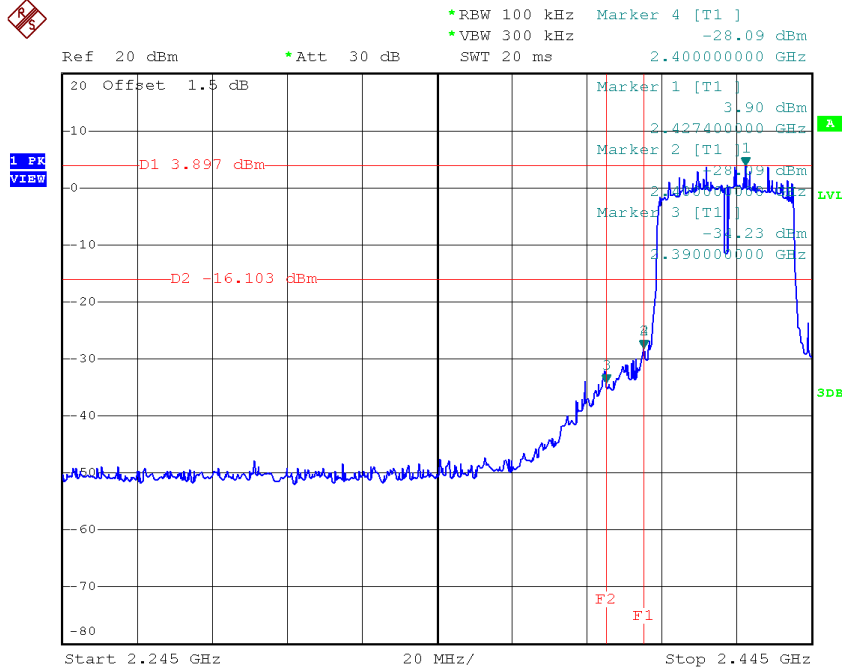

Date: 23.NOV.2018 15:13:22

**TX HT40 mode CH09**

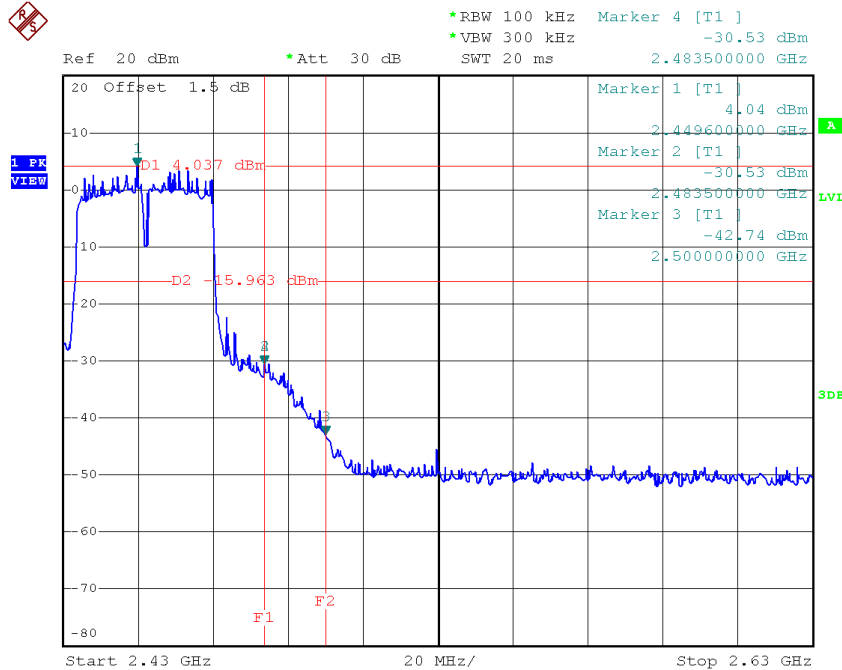

Date: 23.NOV.2018 15:16:03



### TX HT40 mode CH03 (10 Harmonic of the frequency)

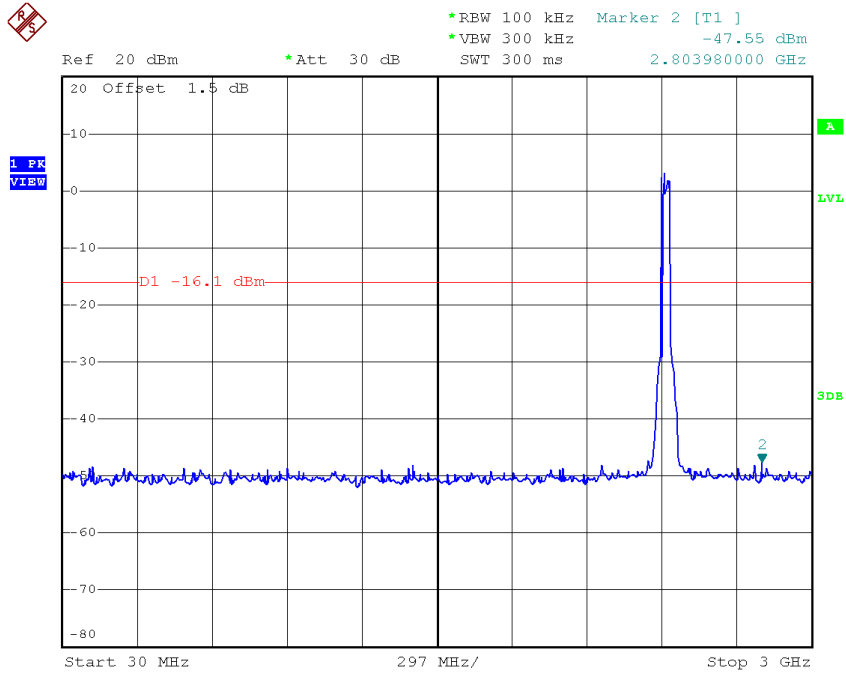

Date: 23.NOV.2018 15:13:36

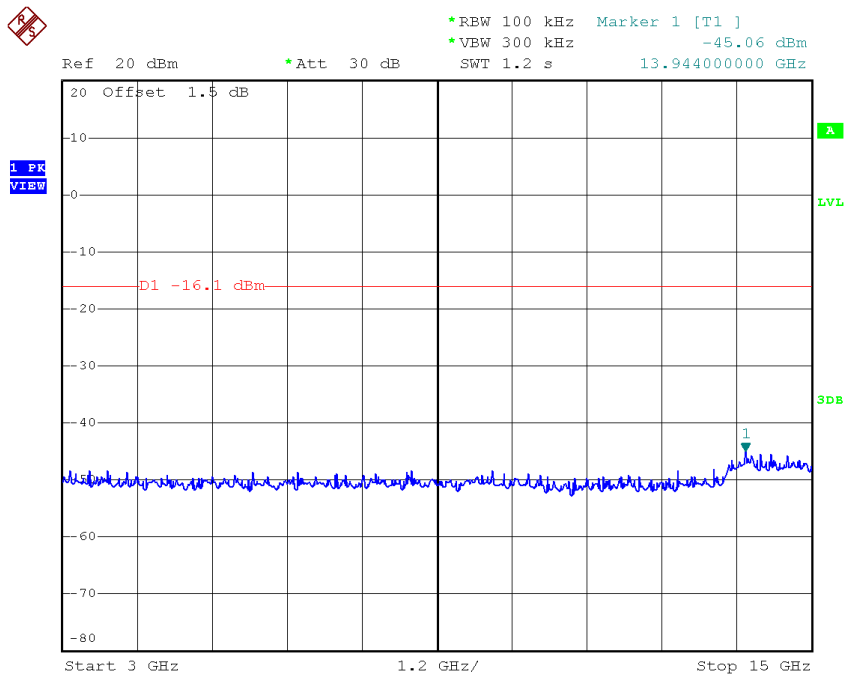

Date: 23.NOV.2018 15:13:44

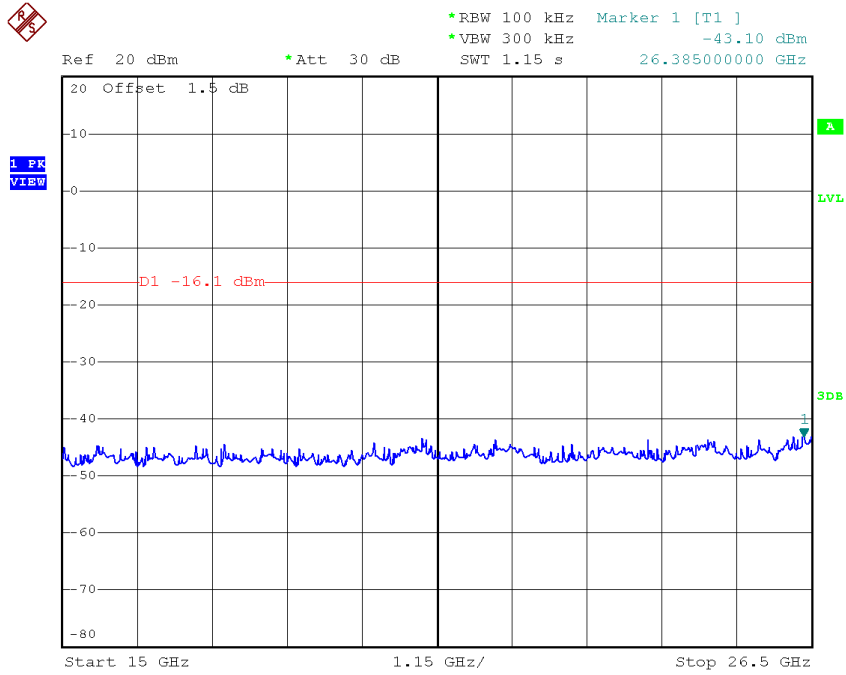

Date: 23.NOV.2018 15:13:53

**TX HT40 mode CH06 (10 Harmonic of the frequency)**

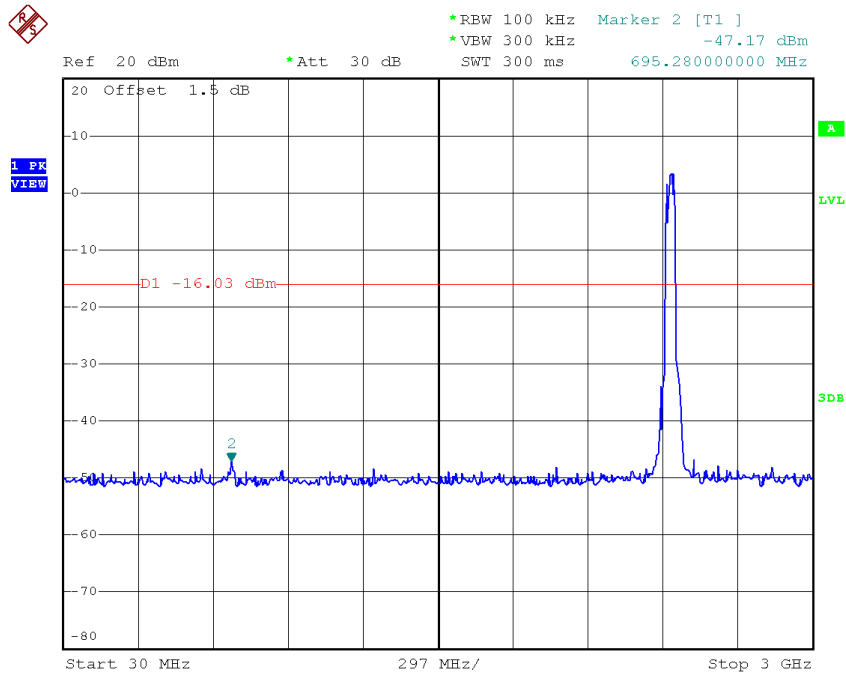

Date: 23.NOV.2018 15:14:59

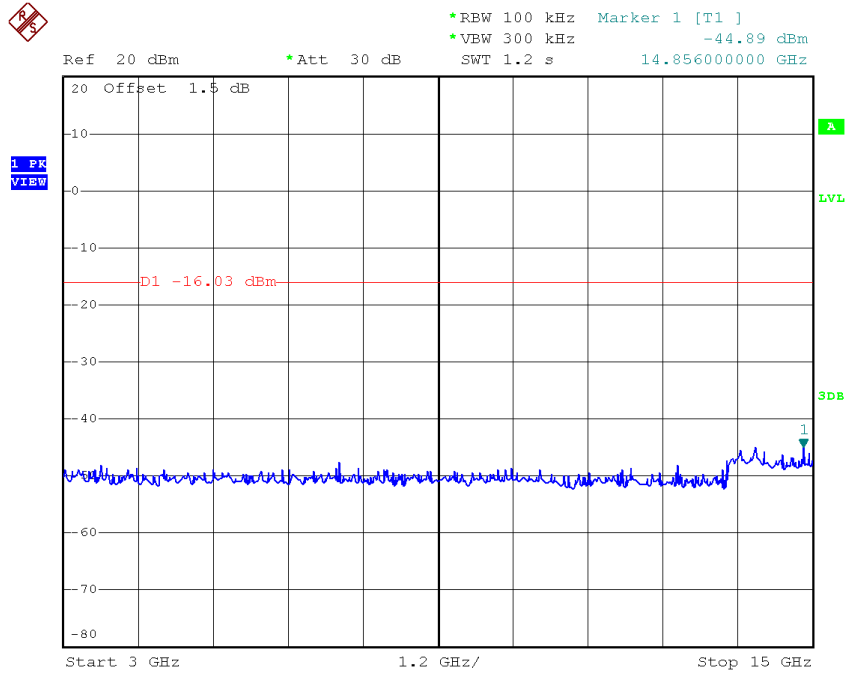

Date: 23.NOV.2018 15:15:07

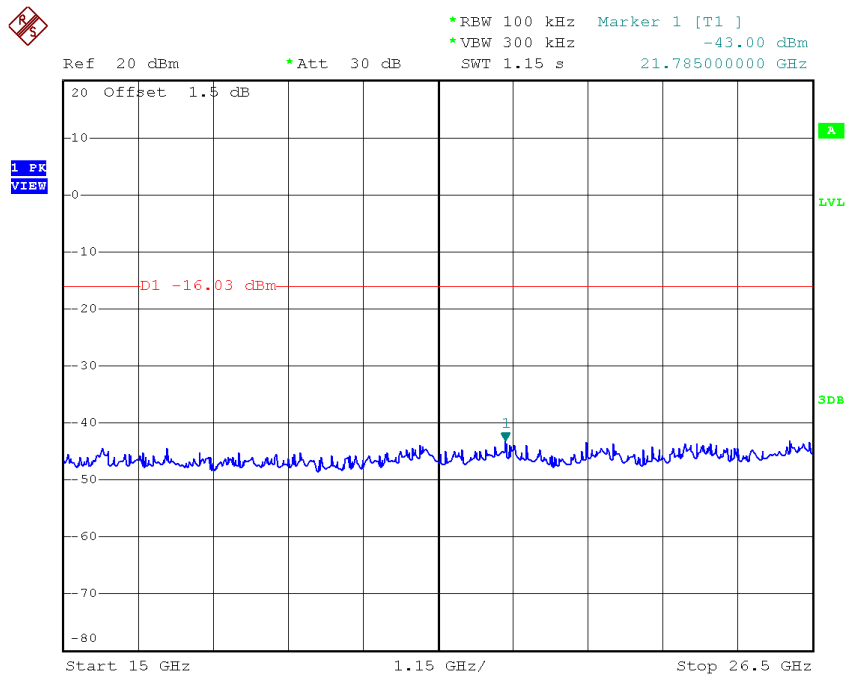

Date: 23.NOV.2018 15:15:16

### TX HT40 mode CH09 (10 Harmonic of the frequency)

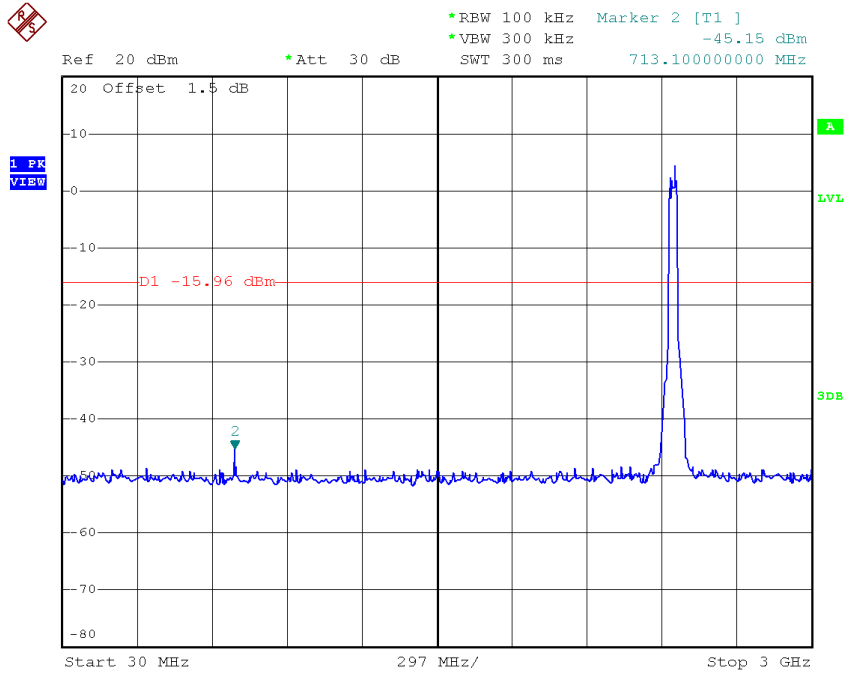

Date: 23.NOV.2018 15:16:17

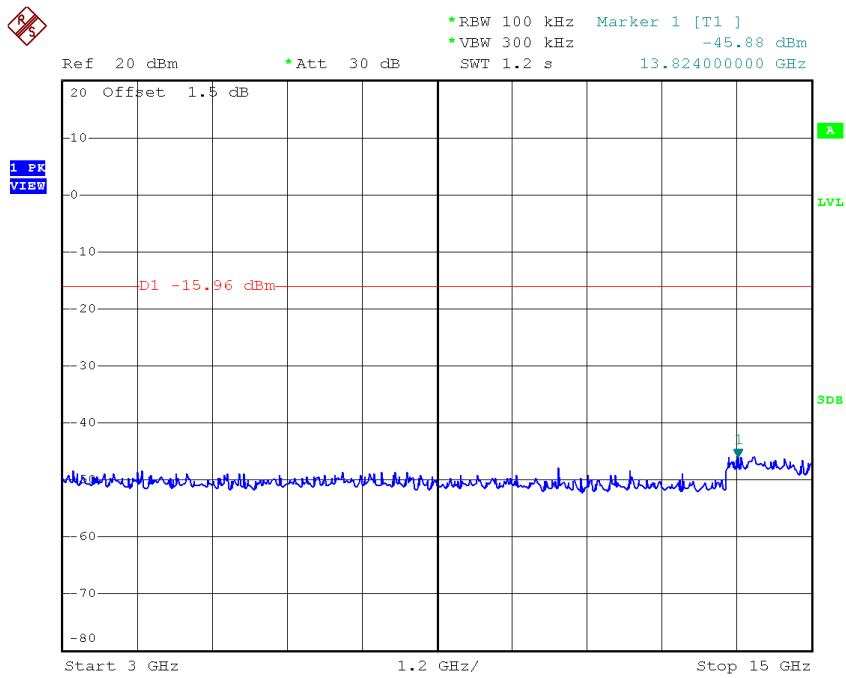

Date: 23.NOV.2018 15:16:26

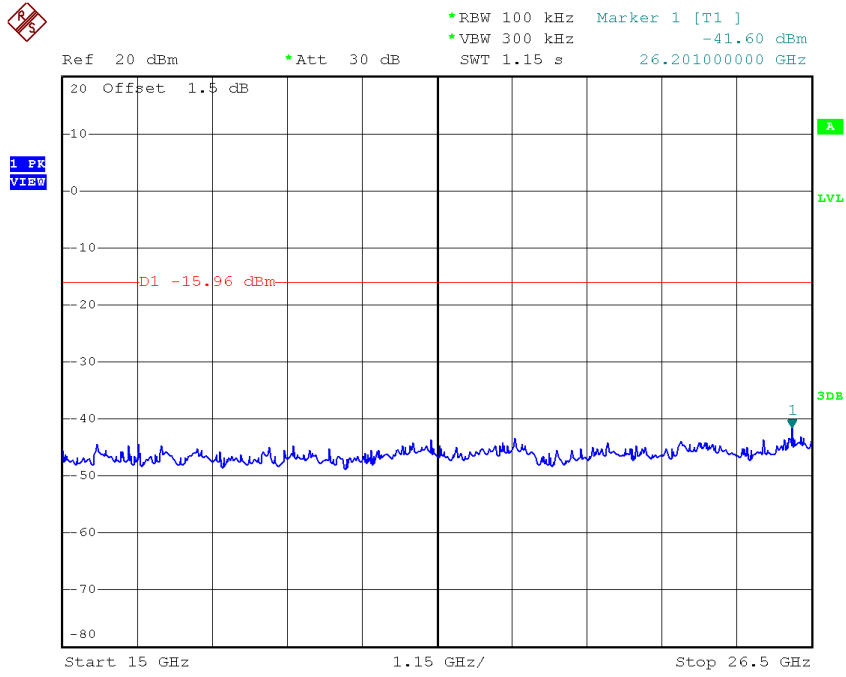

Date: 23.NOV.2018 15:16:34

## APPENDIX H - POWER SPECTRAL DENSITY

**Test Mode: TX B Mode\_CH01/06/11**

Frequency (MHz)	Power Density (dBm/3 kHz)	Power Density (mW/3 kHz)	Max. Limit (dBm/3 kHz)	Result
2412	-2.90	0.5129	8.00	Complies
2437	-1.55	0.6998	8.00	Complies
2462	-2.51	0.5610	8.00	Complies

**TX CH01**

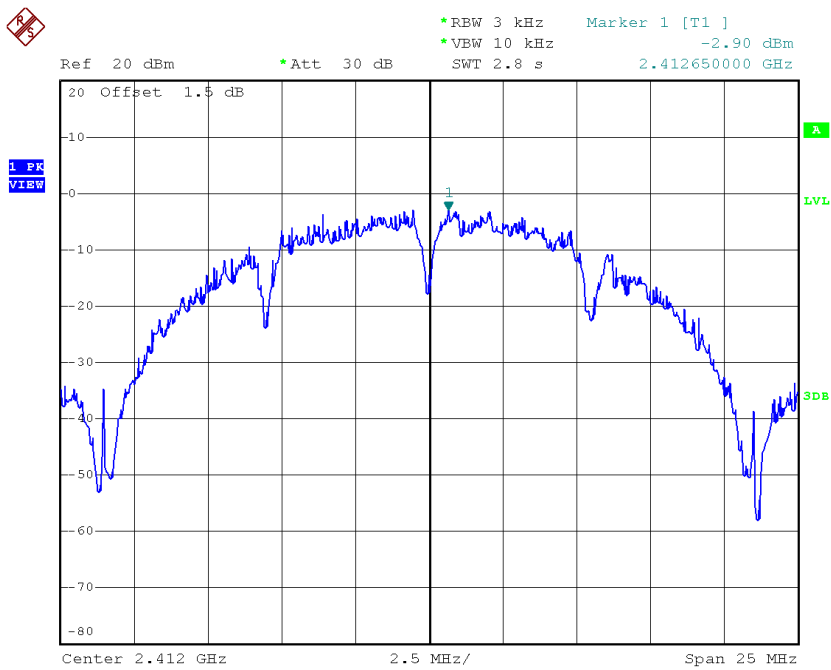

Date: 23.NOV.2018 14:38:52

### TX CH06

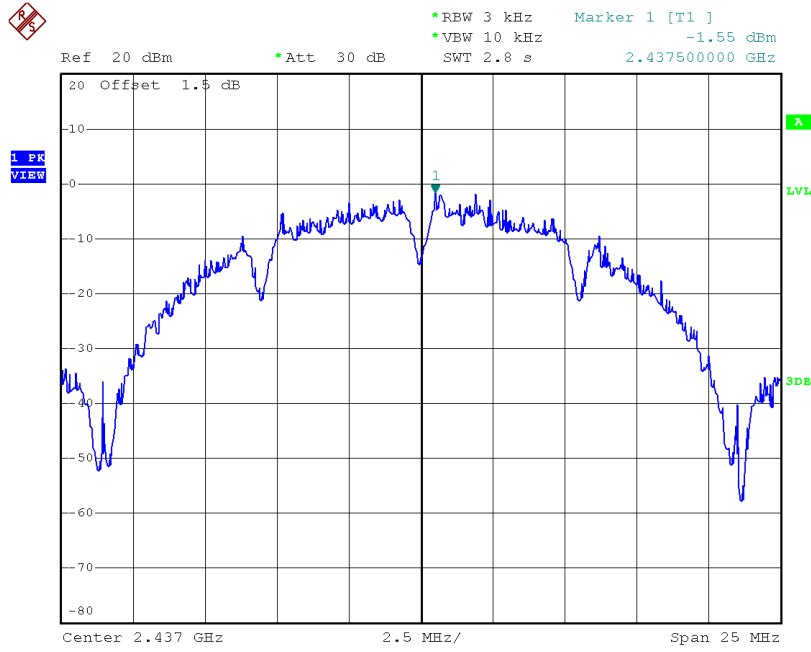

Date: 23.NOV.2018 14:44:33

### TX CH11

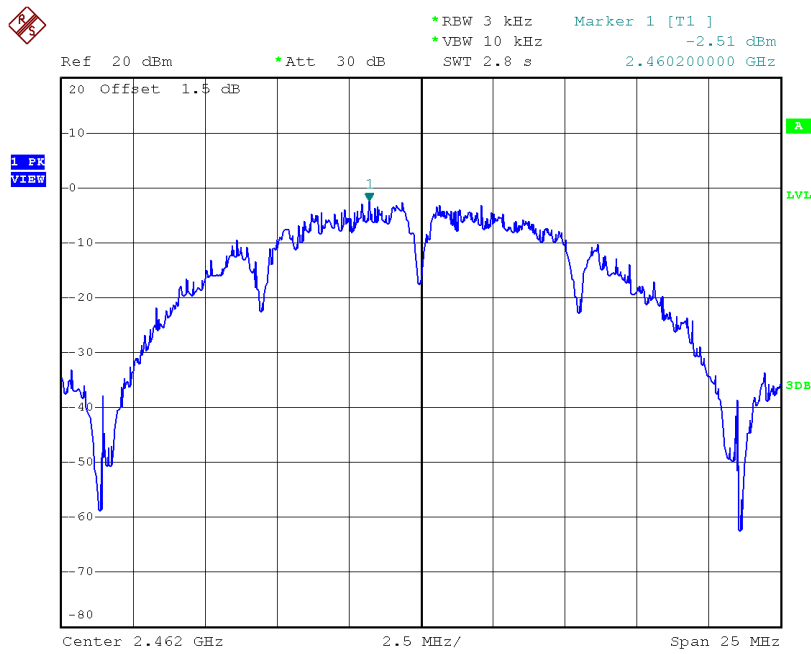

Date: 23.NOV.2018 14:46:25



**Test Mode: TX G Mode\_CH01/06/11**

Frequency (MHz)	Power Density (dBm/3 kHz)	Power Density (mW/3 kHz)	Max. Limit (dBm/3 kHz)	Result
2412	-6.62	0.2178	8.00	Complies
2437	-7.18	0.1914	8.00	Complies
2462	-6.10	0.2455	8.00	Complies

**TX CH01**

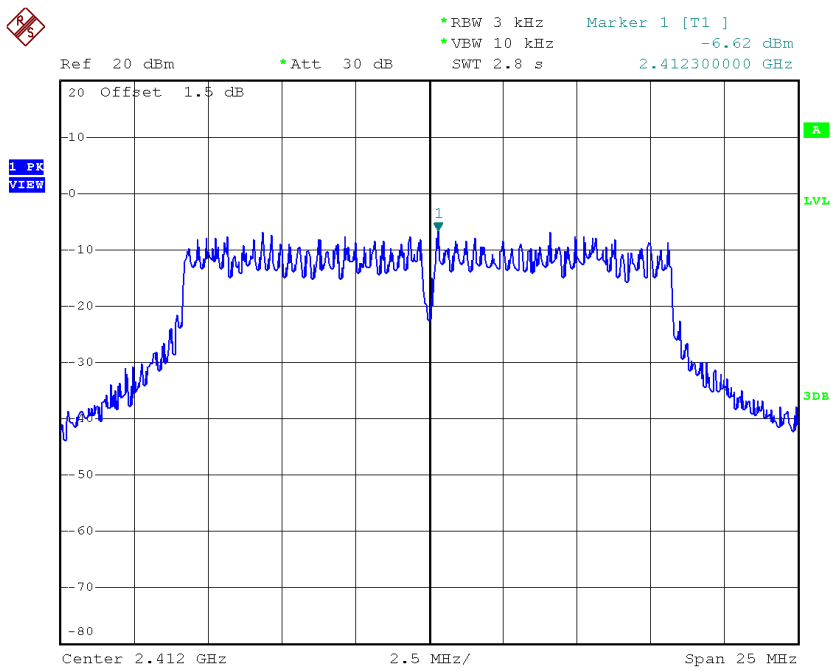

Date: 23.NOV.2018 15:00:38

### TX CH06

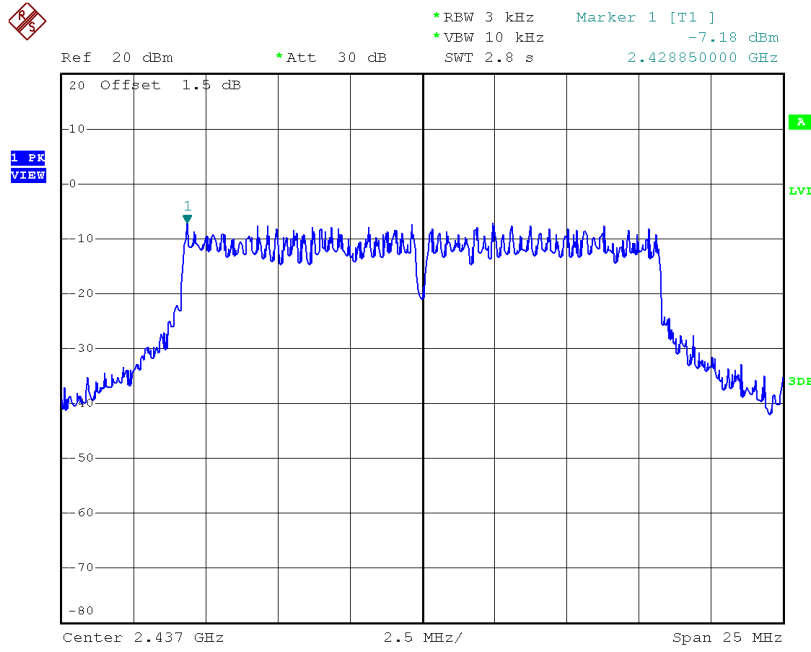

Date: 23.NOV.2018 15:05:51

### TX CH11

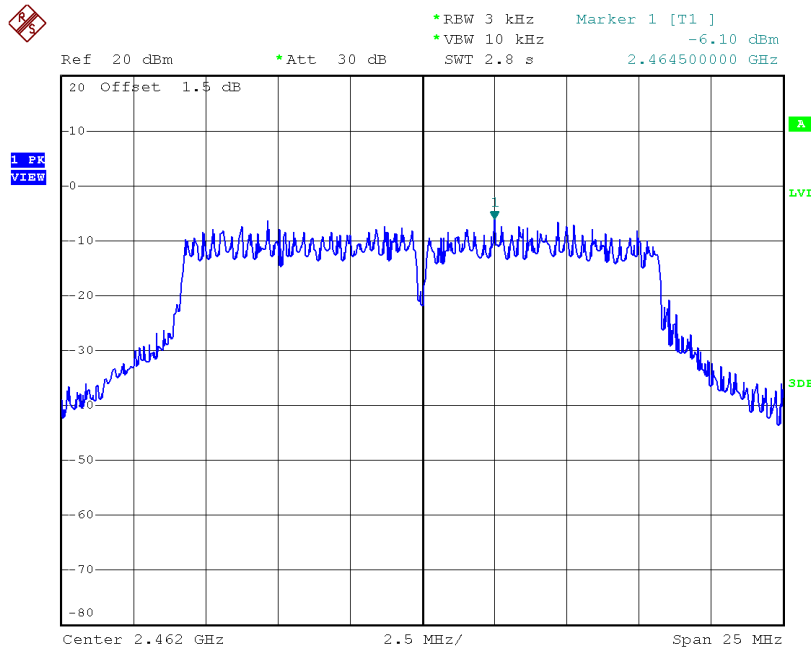

Date: 23.NOV.2018 15:07:20

**Test Mode: TX N-20M Mode\_CH01/06/11**

Frequency (MHz)	Power Density (dBm/3 kHz)	Power Density (mW/3 kHz)	Max. Limit (dBm/3 kHz)	Result
2412	-8.53	0.1403	8.00	Complies
2437	-8.32	0.1472	8.00	Complies
2462	-7.28	0.1871	8.00	Complies

**TX CH01**

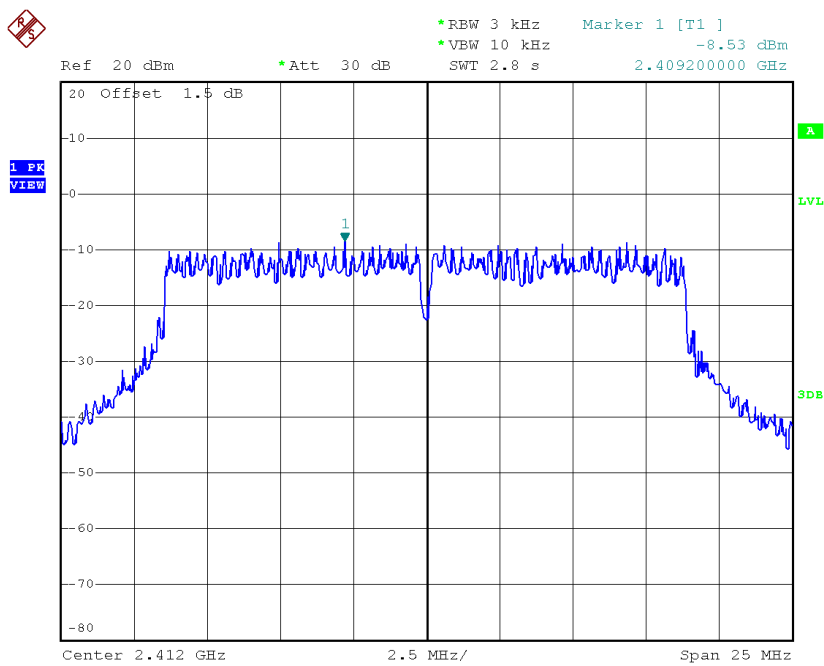

Date: 23.NOV.2018 15:09:40

### TX CH06

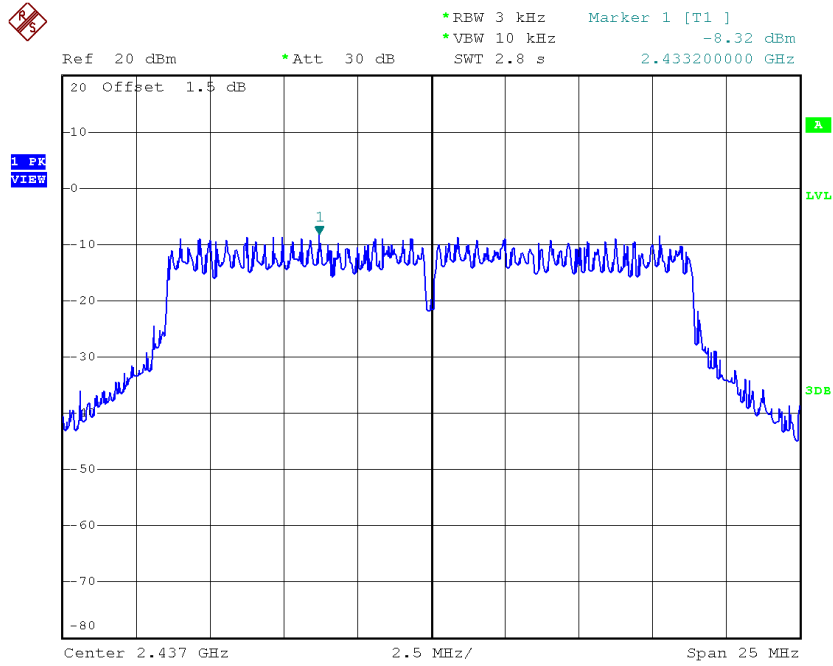

Date: 23.NOV.2018 15:10:57

### TX CH11

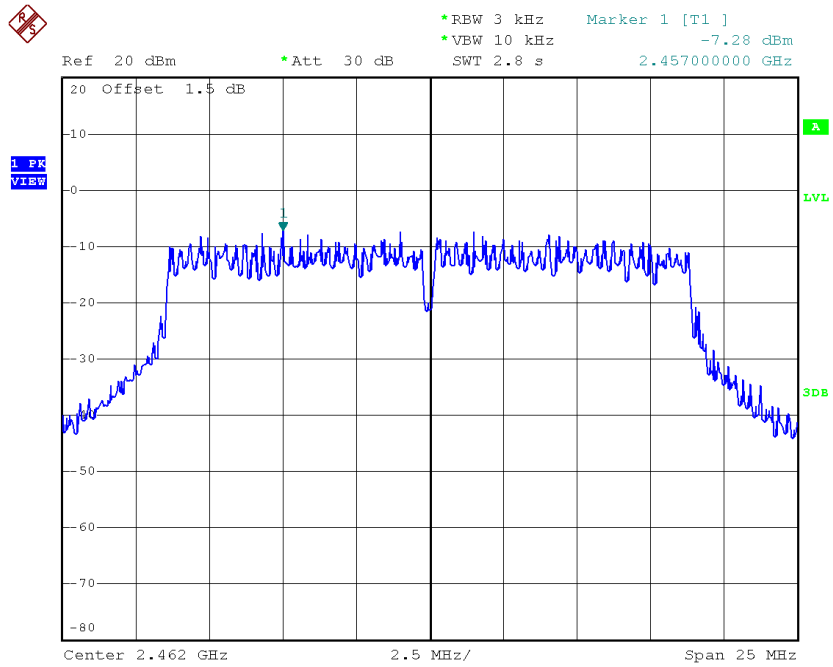

Date: 23.NOV.2018 15:12:18

**Test Mode: TX N-40M Mode\_CH03/06/09**

Frequency (MHz)	Power Density (dBm/3 kHz)	Power Density (mW/3 kHz)	Max. Limit (dBm/3 kHz)	Result
2422	-11.08	0.0780	8.00	Complies
2437	-11.46	0.0714	8.00	Complies
2452	-10.32	0.0929	8.00	Complies

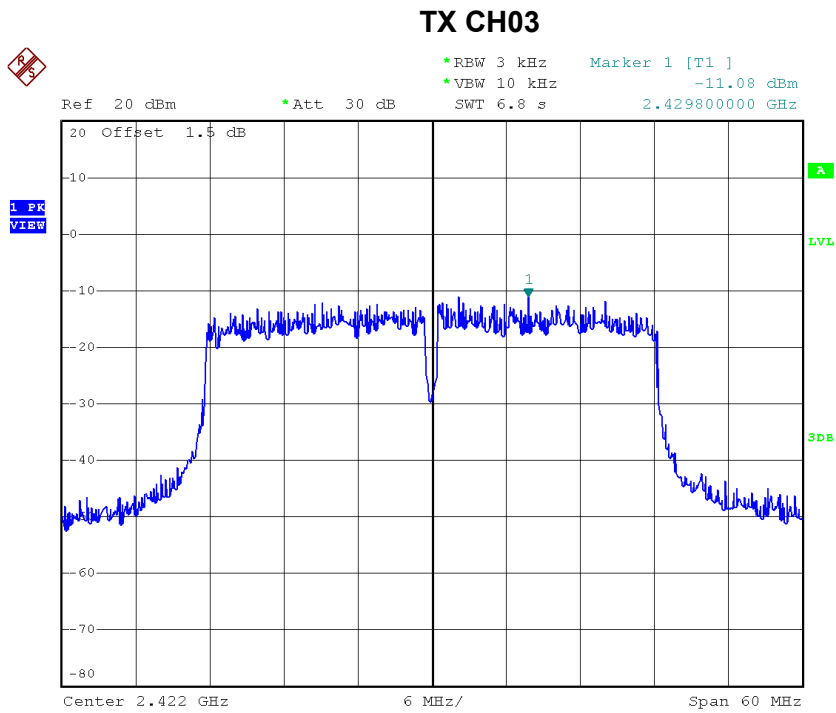

Date: 3.DEC.2018 09:43:18

### TX CH06

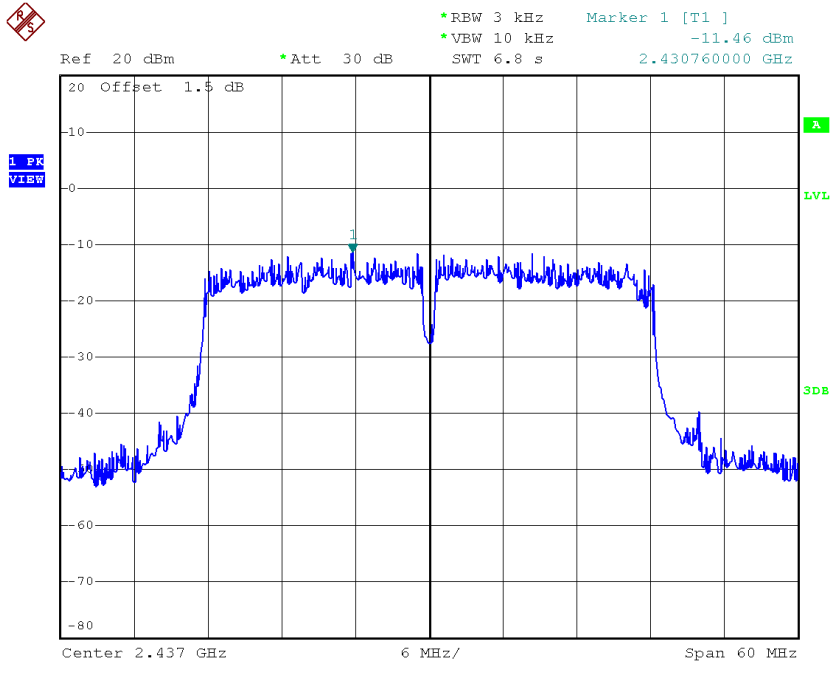

Date: 23.NOV.2018 15:15:28

### TX CH09

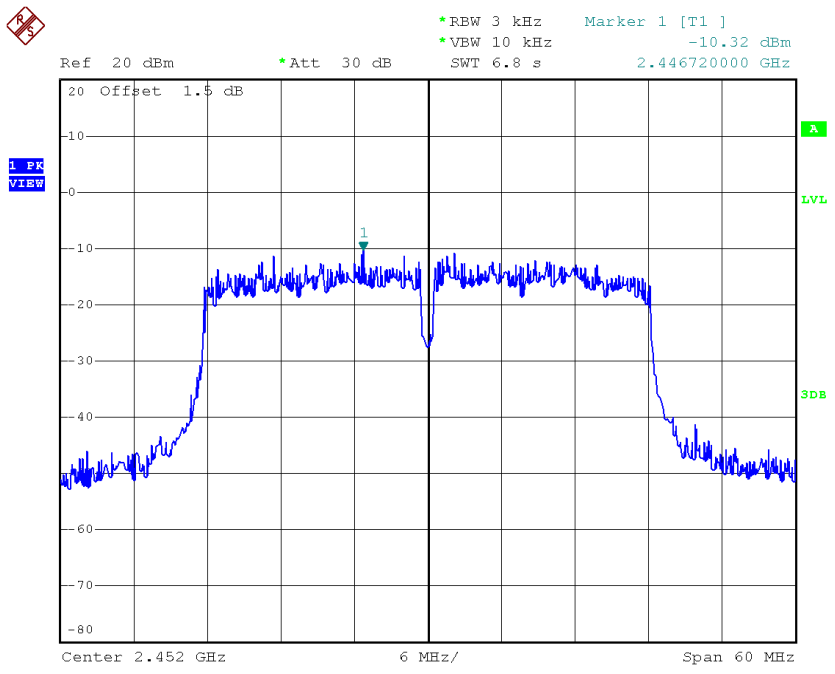

Date: 23.NOV.2018 15:16:46

End of Test Report