



Model: 8001TX

INSTALLATION AND OPERATING INSTRUCTIONS

IF YOU CANNOT READ OR UNDERSTAND THESE INSTALLATION INSTRUCTIONS DO NOT ATTEMPT TO INSTALL OR OPERATE

NOTE: This product is designed for use with an attended hearth appliance or fire feature. Adults must be present when the Control System is operating. DO NOT program or thermostatically set this Control to operate a hearth appliance or fire feature when adults are not physically present. Furthermore, DO NOT leave the hearth appliance or fire feature burning unattended; it may cause damage or serious injury. If an adult is going to be away from the hearth appliance or fire feature for any length of time, then the handheld/wall mount, receiver/control module and application should be in the "OFF" position.

INTRODUCTION

This remote control system was developed to adapt most Skytech Remote Receivers to be operated by Smartplugs which are a part of many Home Automation Systems.

The 8001TX can be added to most pre-existing Skytech remote control systems already installed on an appliance or fireplace. Many Skytech receivers can LEARN up to 3 security codes and you can continue to use your existing transmitter along with 8001TX. Some receivers can LEARN only 1 security code and the 8001TX would replace your existing transmitter. Please check with a Skytech dealer or call us directly at the number listed at the end of this manual if you need help determining the compatibility or features of your current receiver.

The system operates on radio frequencies with non-directional signals. The systems operating range is approximately 30-feet. The system operates on one of 1,048,576 security codes that are programmed into the transmitter at the factory.

TRANSMITTER

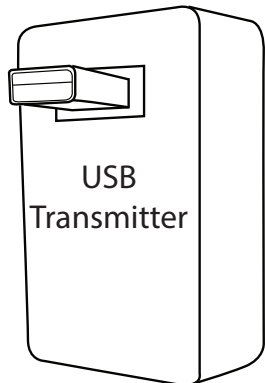

This "Smart Plug Transmitter" system is designed to be used in conjunction with a WI-FI or Bluetooth "Smart Plug" that is controlled by a voice command system (i.e. Alexa or Google) or an app downloaded on a smart phone.

The Smart Plug receives a WI-FI command or a Bluetooth command which creates a chain of command to: 1. Power the Smart Plug with 120VAC. 2. Powers a USB phone charger with 120VAC. 3. Energizes the Smart Adapter Transmitter (5VDC) to send an ON command via Radio Frequency (RF) to a typical Skytech receiver to turn ON a gas appliance or heater. See Basic Operation diagram on page 2.

Note: The USB phone charger may be omitted if the Smart Plug has a switchable USB outlet.

BASIC OPERATION

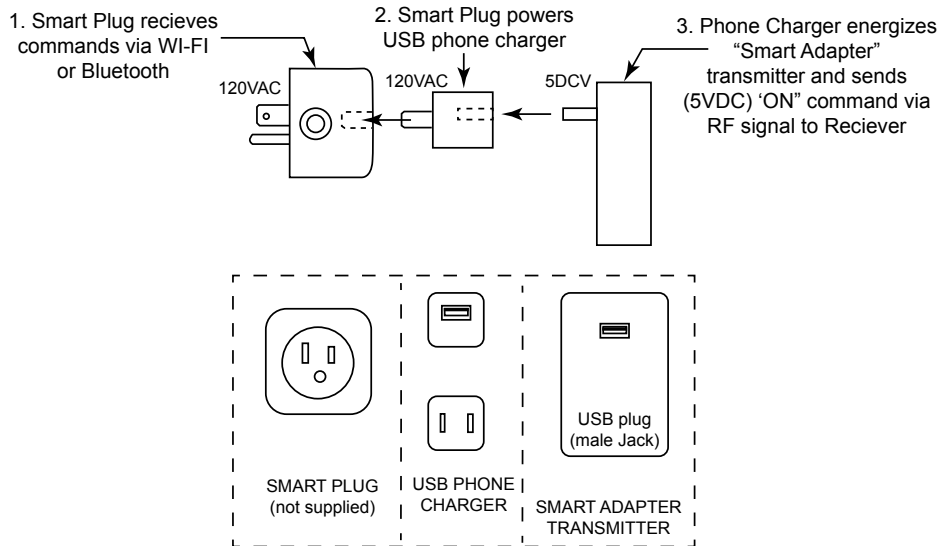

INSTALLATION INSTRUCTIONS

WARNING

This remote control system must be installed exactly as outlined in these instructions. Read all instructions completely before attempting installation. Follow instructions carefully during installation. Any modifications of the remote control or any of its components will void the warranty and may pose a fire hazard.

Do not connect any gas valve or electronic module directly to 110-120VAC power. Consult gas appliance manufacturer's instructions and wiring schematics for proper placement of all wires. All electronic modules are to be wired to manufacturer's specifications.

The following wiring diagrams are for illustration purposes only. Follow instructions from manufacturer of gas valve and/or electronic module for correct wiring procedures. Improper installation of electric components can cause damage to electronic module, gas valve and remote receiver.

INSTALLING TRANSMITTER

Step 1: Ensure the Smart Plug (not supplied) is plugged into a working outlet and it is working properly according to the instructions supplied with the Smart Plug. The Smart Plug can be tested by plugging a light or radio into the plug, turning the light or radio ON and activating the Smart Plug to confirm the Smart Plug operates properly.

Step 2: Unplug the light or radio from the Smart Plug and insert a USB Phone adapter into the Smart Plug.

Note: The USB phone charger may be omitted if the Smart Plug has a switchable USB outlet.

Step 3: Plug the "Smart Adapter Transmitter" into the USB Phone adapter. Installation is now complete.

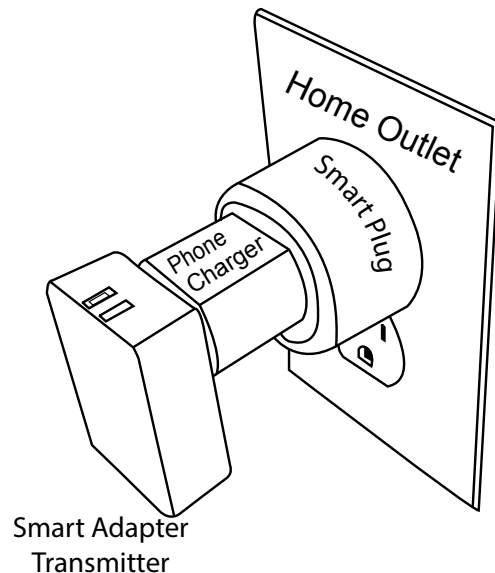

LEARNING TRANSMITTER TO RECEIVER

Each transmitter uses a unique security code. It will be necessary to press and release the LEARN button on the receiver to accept the transmitter security code upon initial use or if a replacement transmitter is purchased from your dealer or the factory. Refer to the LEARNING SECTION of the instructions provided with the Skytech receiver you wish to control.

Locate the LEARN button on the receiver. Then press and release the LEARN button. When you release the LEARN button on the receiver you will hear a “beep”. Next, activate the Smart Plug via voice or Smart Phone app. The green LED light on top of the Smart Adapter Transmitter will illuminate and send a RF signal to the receiver and the receiver will emit three “beeps” confirming the LEARNING process is complete. At the same time the gas appliance will turn ON.

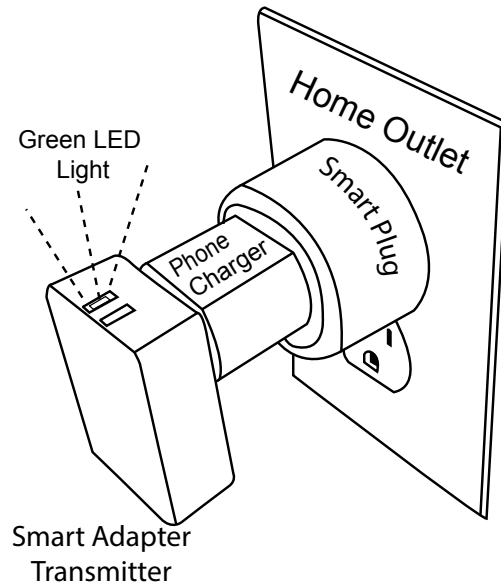

TROUBLE SHOOTING

If you encounter problems with your fireplace system, the problem may be with the fireplace itself or it could be with the remote. Review the fireplace manufacturer's operation manual to make sure all connections are properly made. Then check the operation of the remote in the following manner:

- Make sure the batteries are correctly installed in the RECEIVER. One reversed battery will keep receiver from operating properly.
- See LEARNING TRANSMITTER TO RECEIVER section.
- Be sure Receiver and Transmitter is within 20-25-foot operating range.
- Keep receiver from temperatures exceeding 130° F. Battery life shortened when ambient temperatures are above 130° F.
- If receiver is installed in tightly enclosed metal surround, the operating distance will be shortened.

FCC REQUIREMENTS

NOTE: THE MANUFACTURER IS NOT RESPONSIBLE FOR ANY RADIO OR TV INTERFERENCE CAUSED BY UNAUTHORIZED MODIFICATIONS TO THE EQUIPMENT. SUCH MODIFICATIONS COULD VOID THE USER'S AUTHORITY TO OPERATE THE EQUIPMENT

Federal Communication Commission Interference Statement

This equipment has been tested and found to comply with the limits for a Class B digital device, pursuant to Part 15 of the FCC Rules.

These limits are designed to provide reasonable protection against harmful interference in a residential installation. This equipment generates, uses, and can radiate radio frequency energy and, if not installed and used in accordance with the instructions, may cause harmful interference to radio communications. However, there is no guarantee that interference will not occur in a particular installation.

If this equipment does cause harmful interference to radio or television reception, which can be determined by turning the equipment off and on, the user is encouraged to try to correct the interference by one or more of the following measures:

- Reorient or relocate the receiving antenna.
- Increase the separation between the equipment and receiver.
- Connect the equipment into an outlet on a circuit different from that to which the receiver is connected.
- Consult the dealer or an experienced radio/TV technician for help.

This device complies with Industry Canada license - exempt RSS standard(s).

Operation is subject to the following two conditions:

- (1) This device may not cause interference, and
- (2) This device must accept any interference, including interference that may cause undesired operation of the device.

Cet appareil est conforme aux normes RSS exemptes de licence d'Industrie Canada.

Le fonctionnement est soumis aux deux conditions suivantes:

- (1) Cet appareil ne doit pas causer d'interférences et
- (2) Cet appareil doit accepter toute interférence, y compris les interférences pouvant entraîner un fonctionnement indésirable de l'appareil.

This device complies with RSS 210 of Industry Canada. This Class B device meets all the requirements of the Canadian interferencecausing equipment regulations.

Cet appareil est conforme à la norme RSS 210 d'Industrie Canada. Cet appareil de classe B respecte toutes les exigences du règlement canadien sur le matériel brouilleur.

SPECIFICATIONS

FCC ID No's: K9L8001TX

Canadian IC ID No.'s: 2439A-8001TX

Operating Frequency: 303.8MHz

Operating Power: Transmitter 5VDC, 50-ma Maximum, USB-A

For Technical Service, call:

U.S. INQUIRIES

(855) 498-8324 or (260) 459-1703

CANADIAN INQUIRIES

(877) 472-3923

Skytech Products Group
9230 Conservation Way
Fort Wayne, IN 46809
Sales: (888) 699-6167
Web site: www.skytechpg.com

MANUFACTURED EXCLUSIVELY FOR SKYTECH II, INC



LIMITED WARRANTY

1. **Limited Warranty.** Skytech II, Inc. ("Skytech") warrants that each new Skytech Control System, including all hardware, parts and components (the "System"), when used in accordance with the instructions furnished by Skytech provided with each System, shall be free in all material respects, of defects in materials and any workmanship under normal use, subject to proper installation ("Limited Warranty"). This Limited Warranty is non-transferrable and sets forth our sole and exclusive liability and the sole and exclusive remedies available in relationship to any nonconformity, defect or similar claim. This Limited Warranty only extends to the original retail purchaser of the System (the "Customer") and expires upon any sale or transfer of the home where the System is installed by the Customer.
2. **System Sold As Is.** Subject to this Warranty and any applicable state law, each System is sold by Skytech to a Customers, limitations, reservations of rights, exclusions, and qualifications set forth on Skytech's website, www.skytechpg.com, all of which are considered part of the Warranty and are incorporated herein (collectively, the "Additional Terms"). Each Customer, by purchasing and/or using any System or any portion thereof, does so subject to the Warranty and the Additional Terms.
3. **Installation and Use of System.** Improper Installation, adjustment, alteration, service, or maintenance can cause property damage, personal injury, or loss of life. Thoroughly read the installation and operating instructions of this Control as well as the appliance it will be used in conjunction with as a system. If applicable, read the maintenance instructions before installing this control. This product is designed for use with an attended hearth appliance or fire feature. Adults must be present when the Control System is operating. DO NOT program or thermostatically set this Control to operate a hearth appliance or fire feature when Adults are not physically present. Furthermore, DO NOT leave the hearth appliance or fire feature burning unattended; it may cause damage or serious injury. If an Adult is going to be away from the hearth appliance or fire feature for any length of time, then the handheld/wall mount, receiver/control module and application should be in the "OFF" position.
4. **Repair or Replacement of System or Parts.** Should any System, or any hardware, components and/or parts contained therein fail due to a defect in workmanship or material provided by Skytech after the purchase of a System by a Customer, Skytech shall repair or, at its option, replace the defective System or part, hardware or component, subject to the Customer's compliance with all terms and conditions contained herein governing service and claims under the Warranty. Skytech shall provide replacement parts at no charge for the first (5) five years of this warranty, and at market cost for the Lifetime of the product to the original Customer. Gas valve and gas valve components will be available at no charge for one (1) year. If Skytech does not have the parts for an individual model, then a comparable replacement System will be provided at no charge within the first (5) five years after purchase, and then at market cost for the Lifetime of that product to the Customer.
5. **Warranty Claims; Skytech Service.** To submit a valid claim under the Warranty (each, a "Valid Claim"), a Customer must comply with the following:
 - a) Obtain a Return Material Authorization ("RMA") number from Skytech by calling (855) 498-8324; and
 - b) Provide written notice to a Skytech or an Authorized Dealer ("Dealer") and provide the Name, House Address, Email Address and Telephone Number of the Customer;
 - c) Describe the System model number and nature of the defect, nonconformity, or other problem with the System;
 - d) Provide such notice within thirty (30) days of discovery of such defect, nonconformity, or problem;
 - e) securely pack and ship the defective Skytech Product to Skytech II, Inc. ATTN: Warranty Department at 9230 Conservation, Fort Wayne, IN 46809. Customer assumes all costs and risks associated with transportation to Skytech (i) the RMA number is only valid for thirty (30) days from the date the RMA was issued, (ii) the RMA number should be clearly marked on the outside of each box being returned. Skytech may refuse shipments that DO NOT meet all of the Valid Claim requirements. Skytech is not responsible for any refused shipments or any damage caused due to shipping, whether or not it was a Valid Claim. Skytech shall be responsible for return shipment charges. Compliance with these requirements is a condition to coverage under this Limited Warranty.

Skytech may refuse any shipment(s) that does not meet all of the Valid Claim requirements. Skytech is not responsible for any refused shipments or any damage caused due to shipping, whether or not it was a Valid Claim. Skytech shall be responsible for reasonable return shipment charges for any Skytech System returned whether or not Skytech determines there is no defect with the System, reject for failure of the Customer to submit a Valid Claim, or otherwise determine is not eligible for service under the Warranty.

Upon receipt of a Valid Claim and the properly-returned System, Skytech shall, at its option, either (a) repair the System, at no charge to the Customer, or (b) replace the returned System with a new comparable System, at no charge to the Customer, or (c) provide the Customer with a refund in an amount equal to the price paid by the Customer for the defective System not including any service or labor cost associated with the installation or otherwise. Any System or hardware, component or part repaired by Skytech hereunder, or any replacement System, hardware, component or part shall be shipped to the Customer by Skytech at Skytech's cost and the Warranty, the Additional Terms, and all other terms and conditions set forth herein shall extend to such repaired or replacement System, hardware, component or part. Skytech shall pay no refund before Skytech from the Customer receives the defective System, hardware, component and/or parts. Any obligation of Skytech under this Section 4 shall be and remain subject to Skytech's right to physically inspect the defective System, hardware, component and/or part returned to Skytech by the Customer. Some States do not allow the exclusion or limitation of incidental and consequential damages or limitation on how long an implied warranty lasts, so the above limitation may not apply to you. This warranty gives you specific rights and you may have other rights, which vary from state, province, or nation. To the extent allowable under any law, the liability of Skytech is limited to the express terms of this warranty, and Skytech expressly disclaims any and all implied warranties, including any warranties of fitness for a particular purpose or merchantability.



Print information and detach at dotted line and return to: Skytech Products Group, Attn. Warranty Dept.,
9230 Conservation Way, Fort Wayne, IN 46809 Phone: (855) 498-8224

Warranty Information

Purchase Date: _____ Model: _____ Date Code: _____ (4-digit code printed on product label)

Purchased From: _____

Customer Name: _____ Phone: _____

Address: _____

City: _____ State/Prov. _____ Zip/Postal Code _____

E-mail Address: _____

Please send a Proof of Purchase (original receipt) copy along with your warranty form.