



## RCT-MLT-IV Remote Control Kits

- Installation and Operating Instructions -

### INTRODUCTION

The remote control system can be operated thermostatically or manually from the transmitter. The system operates on radio frequencies (RF) within a 20 foot range. Can be used with DSI, IPI or Standing Pilot systems.

This remote control kit has a hand held transmitter that can be used as a remote on/off or as a thermostat. The transmitter display shows the current room temperature, target temperature, timer setting, on/off status, low battery indicator, current time, burner/valve operation and fan operation. Electrical ratings for the receiver are: 110 VAC, 60 Hz, 6 W.

If pertinent, see additional fireplace wiring diagrams on pages 9 to 11.

### INSTALLATION PRECAUTIONS

This remote control kit is tested and safe when installed in accordance with this installation manual.

**Installation of this kit MUST be done by a qualified service technician.**

**NOTE: A manometer MUST be used to set the manifold pressure on the gas valve.**

It is the responsibility of the installer to read all instructions before starting installation and to follow these instructions carefully during installation. Modification of the remote control system or any of its components will void the warranty and may cause a fire hazard.

**NOTE: The factory installed junction box in the gas fireplace must be wired with 110 VAC before installing this kit. See Installation Instructions section.**

**CAUTION:** All wiring should be done by a qualified electrician and shall be in compliance with local codes and with the National Electric Code ANSI/NFPA No. 70-current (in the United States), or with the current CSA C22.1 Canadian Electric Code (in Canada).

**WARNING: DO NOT CONNECT 110-120 VAC WIRING TO THE GAS CONTROL VALVE OF THIS APPLIANCE.**

### FCC REQUIREMENTS

**WARNING: CHANGES OR MODIFICATIONS TO THIS UNIT NOT EXPRESSLY APPROVED BY THE PARTY RESPONSIBLE FOR COMPLIANCE COULD VOID THE USER'S AUTHORITY TO OPERATE THE EQUIPMENT.**

**NOTE:** This equipment has been tested and found to comply with the limits for a Class B digital device, pursuant to Part 15 of the FCC Rules. These limits are designed to provide reasonable protection against harmful interference in a residential installation. This equipment generates, uses, and can radiate radio frequency energy and, if not installed and used in accordance with the instructions, may cause harmful interference to radio communications. However, there is no guarantee that interference will not occur in a particular installation. If this equipment does cause harmful interference to radio or television reception, which can be determined by turning the equipment off and on, the user is encouraged to try to correct the interference by one or more of the following measures:

- Reorient or relocate the receiving antenna.
- Increase the separation between the equipment and receiver.
- Connect the equipment into an outlet on a circuit different from that to which the receiver is connected.
- Consult the dealer or an experienced radio TV technician for help.

#### Canadian Equipment Requirements

This digital apparatus does not exceed the (Class A/Class B)\* limits for radio noise emissions from digital apparatus set out in the Radio Interference Regulations of the Canadian Department of Communications.

This device complies with Industry Canada license - exempt RSS standard(s).

Operation is subject to the following two conditions:

- (1) This device may not cause interference, and
- (2) This device must accept any interference, including interference that may cause undesired operation of the device.

This device complies with RSS 210 of Industry Canada. This Class B device meets all the requirements of the Canadian interference causing equipment regulations.

Le présent appareil numérique n'émet pas de bruits radioélectriques dépassant les limites applicables aux appareils numériques (de la class A/de la class B)\* prescrites dans le Règlement sur le brouillage radioélectrique édicté par le ministère des Communications du Canada.

Cet appareil est conforme aux normes RSS exemptes de licence d'Industrie Canada.

Le fonctionnement est soumis aux deux conditions suivantes:

- (1) Cet appareil ne doit pas causer d'interférences et
- (2) Cet appareil doit accepter toute interférence, y compris les interférences pouvant entrainer un fonctionnement indésirable de l'appareil.

Cet appareil est conforme à la norme RSS 210 d'Industrie Canada. Cet appareil de classe B respecte toutes les exigences du règlement canadien sur le matériel brouilleur.

**This is a DRAFT copy and is subject to change. It is not approved for release. DO NOT COPY!**  
**INSTALLATION INSTRUCTIONS**

**Wire Colors**

**Installing Electrical Service to the Junction Box**

**WARNING: TURN ELECTRICAL POWER OFF AT THE CIRCUIT BREAKER BEFORE BEGINNING THIS INSTALLATION.**

**NOTE:** Some appliances do not have a cover plate. Instead, there is a hole through which the Romex clamp is attached to the outer wrap.

1. Remove the electrical cover plate from the lower side of the fireplace. Remove the knock-out from the plate and attach the Romex clamp (screws to the outside) (see Figure 1).

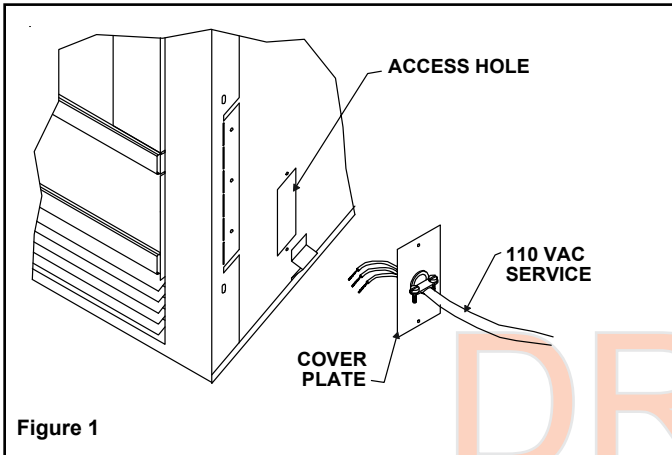

Figure 1

2. Feed the electrical service wires through the Romex clamp and secure the wires to the clamp.
3. Using the wire nuts provided, connect the service wires to the junction box. The black wires to the black service wire, the white wires to the white service wire, and the service ground wire to the ground stud of the junction box.
4. Re-attach the cover plate to the outside of the fireplace.

**WARNING: LEAVE ELECTRICAL POWER OFF AT THIS TIME. DO NOT RESTORE POWER UNTIL THE REMOTE CONTROL SYSTEM IS COMPLETELY INSTALLED.**

**REMOTE RECEIVER**

**Important:** The remote receiver should be positioned close to front in right or left corner where ambient temperatures do not exceed 170° F.

The remote receiver is powered by 110-120VAC. It plugs into a standard polarized duplex receptacle.

**NOTE:** If junction box contains 2-prong receptacles, a standard 3 to 2 prong adapter will be required to be obtained from an independent source.

**Locating Receiver and Operating Functions**

This remote receiver can be positioned under the firebox in the control compartment of the fireplace if ambient temperatures do not exceed 170° F. This system is designed to control the following components:

- Gas Valve - Millivolt or Electronic Ignition ..... Red
- Fan/Blower - 110 VAC ..... Plug from Fan
- Flame Controller - HI/LO solenoid ..... Orange

**RECEIVER WIRING INSTRUCTIONS**

Incorrect wiring connections WILL cause damage to the gas valve or electronic module operating the gas appliance and may also damage the remote receiver.

**Wiring Flame Function (Standing Pilot, DSI, IPI)**

Connect the remote receiver by connecting the two red wires leading from the remote receiver to the red and brown remote wires labeled "FOR USE WITH REMOTE OR WALL SWITCH ONLY". See Figure 2.

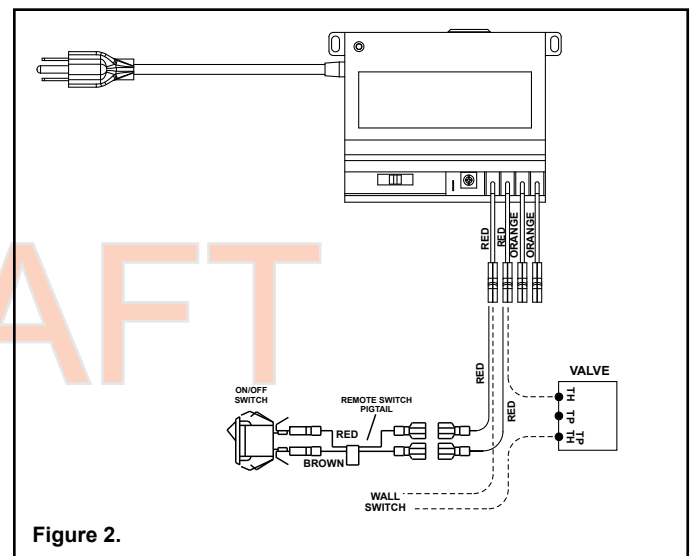

Figure 2.

**Alternative Wiring for units with a wall switch**

Disconnect the wall switch wire from the TH terminal on the valve and connect this wire to male connector supplied on the receiver. Connect remaining female connector from receiver to the TH terminal on the valve.

**Adding Optional Fan/Blower**

Plug 2-prong fan cord directly into the 3 prong polarized plug on the back of the receiver (see Figure 3). This receptacle output is 110/120 VAC, 3 AMP.

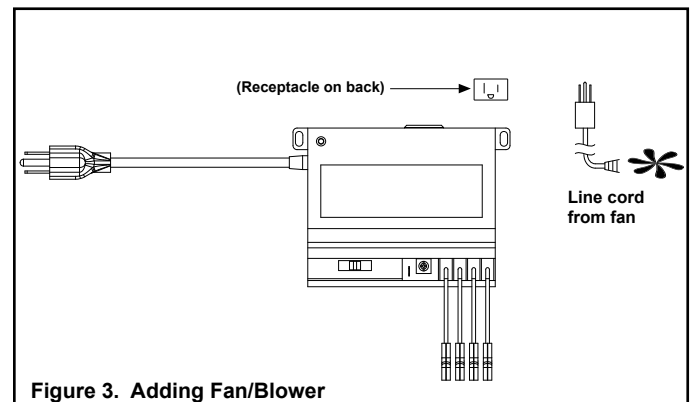

Figure 3. Adding Fan/Blower

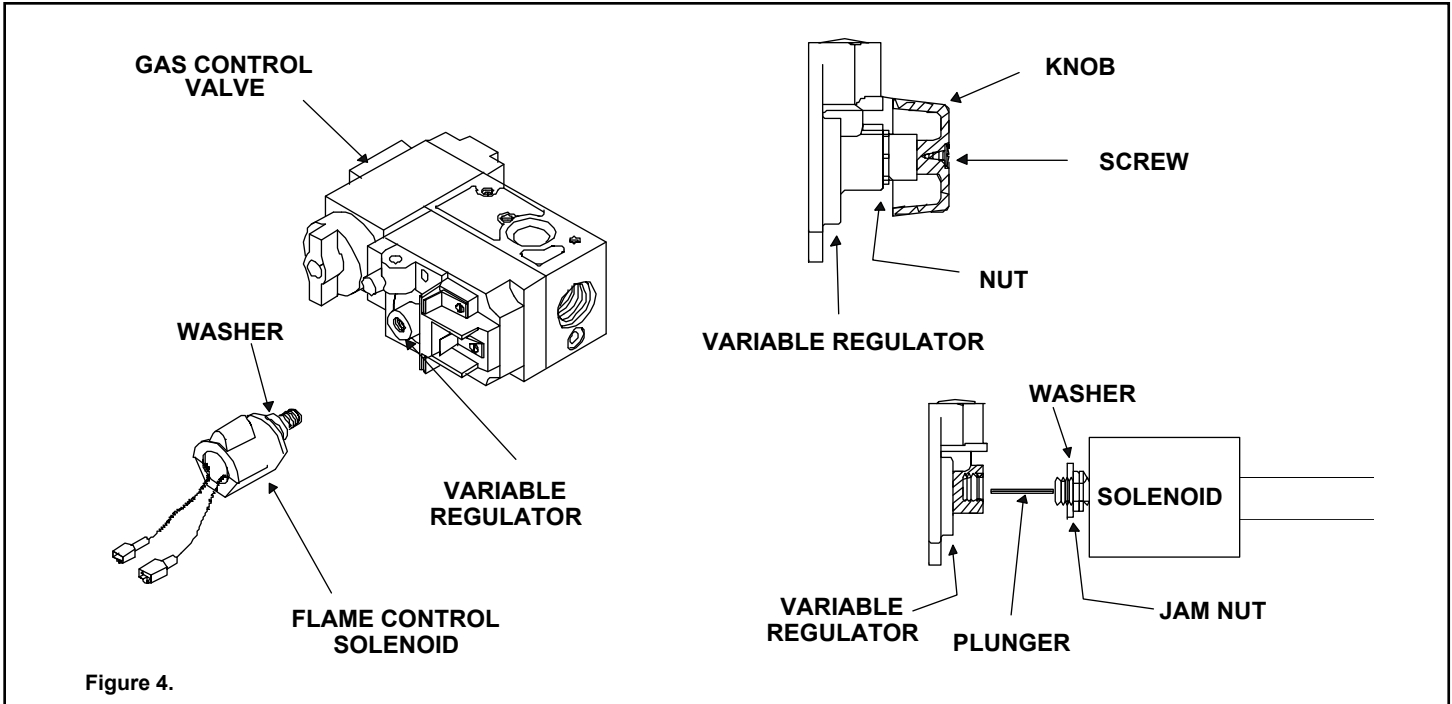

Figure 4.

**NOTE: All steps required for installation of the flame controller MUST be done by a qualified gas service technician.**

6. Tighten the jam nut (see Figure 4) to the face of the variable regulator body.
7. Turn the main gas knob on the gas valve OFF.
8. Remove the manometer from the pressure tap and screw the tap closed.

### Installing Flame Control Solenoid

1. Remove the screw and knob from the variable regulator and discard.
2. Unscrew the nut from the regulator and discard.
3. Remove the bag containing a washer and blue and red plungers from the side of the flame control solenoid.
4. Place washer on flame control solenoid (see Figure 4).
5. Insert the correct plunger (blue - natural gas, red - propane) into the flame control solenoid (see Figure 4).
6. Thread the flame control solenoid with correct plunger into the thread hole in the variable regulator. Turn one to two turns only. Do not tighten or damage may occur.

### Wiring the Flame Controller

1. Connect the two leads from the flame control solenoid to the orange leads from the receiver (see Figure 5).
2. Install a manometer into the pressure tap.

**NOTE: A manometer MUST be used to set the manifold pressure on the gas valve.**

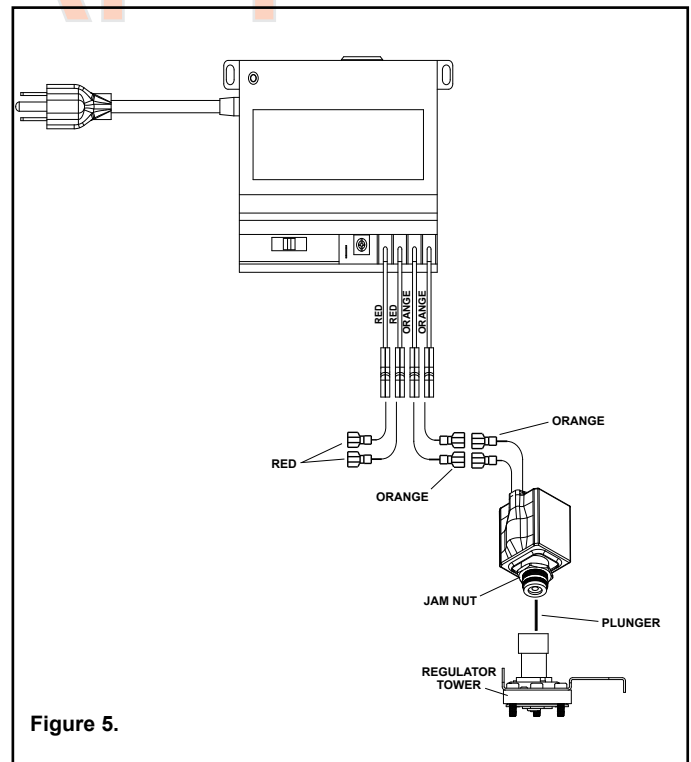

Figure 5.

3. Plug the remote receiver into the 110/120 VAC power supply.
4. Light the fireplace as directed in the Owner's Manual.
5. Set the manifold pressure on the gas valve by rotating the flame control solenoid. Adjust until the reading on the manometer is 3.5 inches w.c. for natural gas, or 10.0 inches w.c. for propane.

**This is a DRAFT copy and is subject to change. It is not approved for release. DO NOT COPY!**  
**TRANSMITTER**

The remote receiver has a 3-position slide switch: OFF/ REMOTE/ON (see Figure 6).

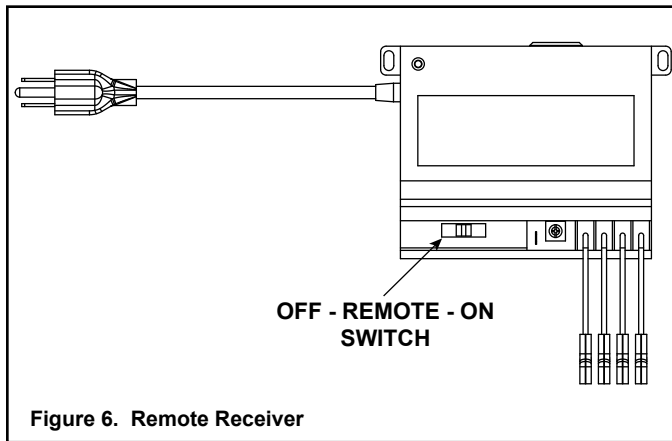

Figure 6. Remote Receiver

**NOTE:** The remote receiver will only respond to the transmitter when the 3-position slide button on the remote receiver is in the Remote position. If the system does not respond to the transmitter on initial use, see section Matching Security Codes.

1. With the slide switch in the ON position, the system is on.
2. With the slide switch in the REMOTE position, the system only operates if the remote receiver receives commands from the transmitter.
3. With the slide switch in the OFF position, the system is off.

**NOTE:** The slide switch should be placed in the OFF position if you will be away from your home for an extended period of time. Placing the switch in the OFF position also functions as a safety “lock out” by turning the system off and rendering the remote receiver inoperative.

**Important:** Before operating remote control, transmitter and receiver must have matching security codes. See section ‘Matching Security Codes’.

**Important:** Review ‘Thermo-Updating/Communication-Safety Features’ under ‘Transmitter Safety Features’ section. Communication Safety features shut down the fireplace system when a potentially unsafe condition exists.

**Important:** Review ‘Auto Shutdown’ section. This safety feature shuts down the fireplace after 9 hours of continuous operation, in ON mode only.

**Important:** New or fully charged batteries are essential for proper operation of the multi-function transmitter. The transmitter operates on 2 AAA-size 1.5V batteries. Use Alkaline batteries for longer battery life and maximum operational performance.

Insert 2 AAA-size 1.5V batteries into the battery compartment on the back of the transmitter. When the batteries are correctly inserted, the screen will display numbers (see Figure 7 for LCD Display Screen).

**NOTE:** If the transmitter is activated from a very cold condition it may be necessary to allow the transmitter to stabilize to room temperature (could take up to 15 minutes) before accurate room temperatures are displayed on the screen.

**NOTE:** LCD screen is equipped with a “backlite” for easier viewing of LCD screen. Backlite illuminates when a function button is depressed. After 5 seconds elapses, LCD screen will return to its normal state.

1. **LOW** - Battery power low. Replace batteries within two weeks.
2. **TIMER** - Indicates time remaining before system shuts off, when timer-programmed, 9 - hour maximum setting.
3. **MODE** - Indicates operation MODE of system. ON indicates the system is on, either manually or thermostatically. THERMO indicates the system will automatically cycle ON/OFF, depending on programmed SET temperature. OFF indicates the entire system is turned off.
4. **SET** - Indicates desired SET room temperature for THERMO operation.
5. **FLAME** - Single or double Flame/Hi icon indicates burner/valve operational.
6. **CLOCK** - Indicates the current time in AM/PM.
7. **ROOM** - Indicates CURRENT room temperature.
8. **°F** - Indicates degrees Fahrenheit (°C indicates degrees Celsius).
9. **FAN** - Indicates fan is on or programmed to come on. Three speed settings are available.

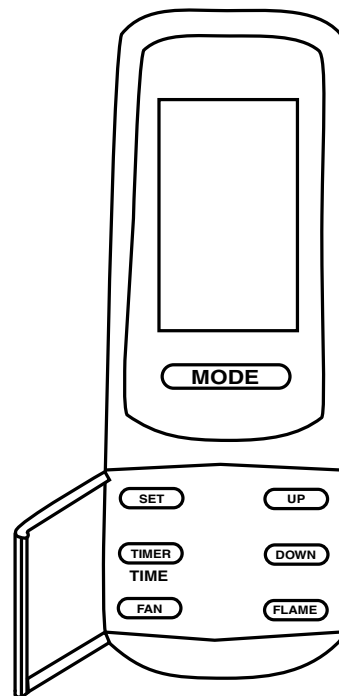
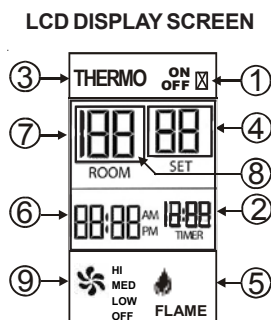

Figure 7. Transmitter LCD Display Screen

## MATCHING SECURITY CODES

It may be necessary to program the remote receiver to the security code of the transmitter upon initial use, if batteries are replaced, or if a replacement transmitter is purchased from your dealer. To program the remote receiver:

1. Set the slide button on the receiver to the REMOTE position.
2. Push the LEARN button (one beep will be heard) on the top of the remote receiver.
3. Then press the MODE button on the transmitter. Several beeps indicate the transmitter's code has been programmed into the receiver. When an existing receiver is matched to a new transmitter, the new security code will overwrite the old one. **NOTE:** When the LEARN button is depressed, "beeping" sounds should be heard. If no "beeping" is heard check to see that the receiver has 110-120VAC power to it.

If you are unsuccessful in matching the security code on the first attempt, wait 1-2 minutes before trying again.

## OPERATING INSTRUCTIONS

To operate the system, press the MODE button (Figure 7) on the transmitter to select the operational MODE desired.

- ON indicates the system is on, either manually, timed or thermostatically.
- THERMO indicates the system will automatically cycle ON/OFF, depending on programmed set temperature.
- OFF indicates the entire system is turned off.

## Transmitter Settings

Flip open the plastic cover on the front of the transmitter to expose the "SET" buttons.

**NOTE:** Flashing numbers on the display indicate the system is waiting for input, such as using the UP and DOWN buttons to program a new setting. If no change is made to flashing digits within 15 seconds, the system will complete the procedure last programmed and reset the display to its normal state.

### Setting the Clock

1. Press and hold the TIMER/TIME button on the transmitter for more than two seconds. The hour digit(s) will begin flashing (see Figure 7, Location #6).
2. Press the UP or DOWN button until the desired hour is displayed in AM or PM.
3. After setting the desired hour, press and release the TIMER/TIME button again to set the minutes; the minute digits will begin flashing.
4. Press the UP or DOWN button until the desired minutes are displayed.
5. Press and hold the TIMER/TIME button again for more than two seconds. The time digits will cease flashing, indicating the clock has been successfully set. You may also press the SET button on the transmitter to stop the time digits from flashing and set the time.

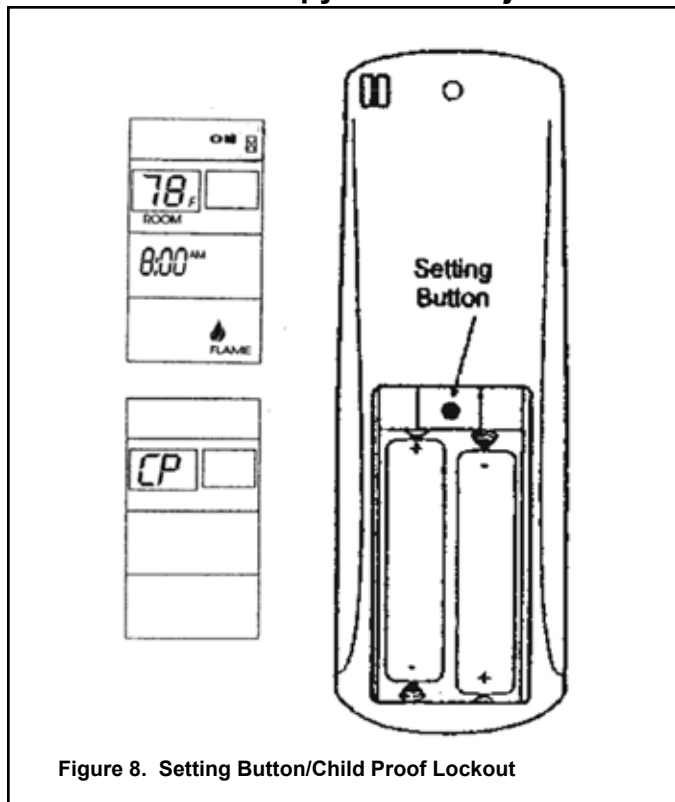

### Setting °F/°C Scale

The factory setting for temperature is degrees Fahrenheit (°F). To change this setting to degrees Centigrade (°C):

1. Remove the battery cover on the back of the transmitter and locate the "setting button" at the top center of battery compartment (see Figure 8).
2. Push setting button and °F will begin flashing on the LCD screen (see Figure 7, Location #8).
3. Push the DOWN button on the transmitter to change °F to °C.
4. Push "setting button" on transmitter and Centigrade (°C) degree readings will display on LCD screen.
5. Repeat this process to change back to Fahrenheit (°F) reading, this time pushing the UP button. **NOTE:** LCD screen will return to normal state if setting button is not pushed within 15 seconds.

### Setting Desired Room Temperature -

#### Thermo Operations

This remote control system can be thermostatically controlled when the transmitter is in the THERMO mode. (THERMO must be displayed on the screen). The transmitter will "sense" the room temperature every two minutes automatically turning the fireplace ON or OFF thermostatically. To set the desired room temperature:

1. Press the MODE button to place the transmitter into THERMO mode. THERMO ON or OFF will display.
2. Press the UP or DOWN button to select the desired room temperature. The highest SET temperature is 99° F (32° C). The lowest SET temperature is 45° F (6° C).

**NOTE:** To prevent repeated thermo-cycling of the gas appliance, the sensing unit in the transmitter will only activate the remote receiver when the temperature change exceeds 2° F (1° C) above or below the SET (desired) temperature.

When the transmitter is in the THERMO mode, it should be kept away from direct sources of heat such as fireplaces, incandescent lighting and direct sunlight. Leaving the transmitter in direct sunlight, for example, will cause it to read the room temperature higher than it actually is.

### Setting the Countdown Timer

This remote control system can operate with a built-in countdown timer when the transmitter is in the ON or THERMO modes (THERMO or ON must be displayed on the LCD screen).

1. Press and release the TIMER/TIME button on the transmitter. The word TIMER and 0:15 flash on the screen (see Figure 7, Location #2).
2. Press the UP and DOWN button to begin advancing through each of the countdown time options. Available countdown times are 15 min, 30 min, 45 min, 1 hour, 1 hr 30 min, and each additional half hour up to nine hours.
3. To set the TIMER, press the SET button on the transmitter. If the system is ON, it will remain on until the "time" has expired. If the system is in the THERMO mode, it will cycle on and off as the room temperature requires until the "time" has expired.

**NOTE:** When the timer is used in the THERMO mode, the THERMO operation will discontinue when the "time" has expired.

### Operating the Fan -

#### Operates in ON or THERMO mode

This remote control system has the capability of operating a 110 VAC fan or blower system that may be included with your gas fireplace. The fan will only operate when the transmitter is in the ON or THERMO mode. (THERMO or ON must be displayed on LCD screen).

1. To turn fan ON, press and release the FAN button on the transmitter (see Figure 7, Location #9). The fan will operate at HI speed, and fan blade icon will appear on LCD screen.
2. To change fan speed to MED, press and release FAN button again. To change fan speed to LO, press and release FAN button again.
3. To turn fan OFF, press and release FAN button again. Fan blade icon will disappear from LCD screen.

**This is a DRAFT copy and is subject to change. It is not approved for release. DO NOT COPY!**

### **Adjusting the Flame Height -**

#### **Operates in ON or THERMO mode**

This remote control system allows the user to control the height of the FLAME when the gas valve is factory equipped with a FLAME CONTROLLER.

1. Press and release FLAME button to change flame height to HI (see Figure 7, Location #5), (a second flame icon appears).
2. Press again to return flame to normal state.

#### **Low Battery Indicator**

An "X" outlined by a battery on the right side of the LCD screen will appear when battery power has dropped significantly. At this time, approximately two weeks of battery power remains.

#### **Child Proof Lockout (CP)**

The transmitter contains a "Child Proof" lockout feature that prevents unauthorized use of the remote control. To access the "Child Proof" activation button, remove cover on BACK of transmitter. To activate LOCKOUT:

1. Press and hold in the "setting button" for 5 seconds. The letters CP will display on the LCD screen (see Figure 8). This prevents the activation of fireplace. When any function button is pressed ON/OFF etc. the letter CP will display on the LCD screen.

To deactivate LOCKOUT:

1. Press and hold in the "setting button" for 5 seconds. The LCD will display CP until 5 seconds have elapsed, and then the LCD screen will return to its normal state.

## **TRANSMITTER SAFETY FEATURES**

It is recommended that the TRANSMITTERS always be located within a 20 foot operating range of the fireplace, preferably in the same room in which the fireplace system is located. The TRANSMITTER features several safety features that alert the user when the TRANSMITTER is placed outside the 20 foot normal operating range.

#### **Thermo-Updating and Communication-Safety Features**

This remote control has a COMMUNICATION-SAFETY function built into its software. It provides an extra margin of safety when the TRANSMITTER is out of the normal 20 foot operating range of the receiver. It is also activated when the batteries become weak or are removed from the transmitter.

In the THERMO-UPDATING feature (only in the THERMO or TIMER modes) the transmitter normally reads the ROOM temperature every 2 minutes. In addition to checking the temperature, the transmitter sends a signal to the receiver indicating that the transmitter and its batteries are still active.

In the COMMUNICATION-SAFETY feature, at all times and in all OPERATING MODES the transmitter sends a signal every fifteen (15) minutes to the receiver, indicating that the transmitter is within the normal operating range of 20 feet.

Should the receiver NOT receive a transmitter signal every 15 minutes (COMMUNICATION-SAFETY feature), the RECEIVER will begin a 2 HOUR (120 minute) countdown timing function. If during this 2 hour period, the receiver does not receive a signal from the transmitter, the RECEIVER will shut down the fireplace being controlled by the receiver. The RECEIVER will then emit a series of rapid "beeps". Then, after 10 rapid "beeps", the RECEIVER will continue to emit a single "beep" every 4 seconds until a transmitter signal is again received. The intermittent 4 second beeping will go on indefinitely until reset.

To "reset" the RECEIVER and operate the fireplace system:

1. Press the MODE button on the transmitter. The word ON must display on the LCD screen. The COMMUNICATION-SAFETY operation is overridden and the system will return to normal operation depending on the MODE selected at the transmitter.

We recommend the user check the batteries in the TRANSMITTER to make sure the voltage is no less than 2.7 volts.

#### **Auto Shutdown**

This remote control has an Auto Shutdown feature incorporated into its system. When the transmitter MODE is in the ON position the fireplace will continuously operate for 9 hours. After 9 hours, the fireplace will shut down. To relight the fireplace:

1. Press the MODE button. The fireplace will operate continuously for up to 9 hours before Auto Shutdown repeats cycle. The Auto Shutdown signal comes from the transmitter. The transmitter must be positioned within a 20 foot operating range for the Auto Shutdown feature to operate.

## **SYSTEM CHECK**

#### **Millivolt Valves**

Light the appliance following the lighting instructions that came with the fireplace. Confirm that the pilot flame is on. It must be in operation for the main gas valve to operate.

1. Slide the 3-position button on the remote receiver to the ON position. The main gas flame (i.e., the fire) should ignite.
2. Slide the button to OFF. The flame should extinguish (the pilot flame will remain on).
3. Slide the button to REMOTE (the center position), then press the MODE button on the transmitter to change the system to ON. The main gas flame should ignite.
4. Press the MODE button on the transmitter to change the system to OFF. The flame should extinguish (the pilot flame will remain on).
5. Press the MODE button on the transmitter to change the system to THERMO.
6. Advance the SET temperature on the transmitter to a temperature of at least 2° F (1° C) above the ROOM temperature displayed on the LCD screen and the system flame will ignite.

**This is a DRAFT copy and is subject to change. It is not approved for release. DO NOT COPY!**  
**GENERAL INFORMATION**

7. Set the SET temperature to at least 2° F (1° C) below the room temperature and the system flame will extinguish. Thereafter, it should continue to cycle on and off thermostatically approximately every two minutes as the ROOM temperature changes, but only when the temperature differential between ROOM and SET temperatures differs at least 2° F (1° C). The 2° F differential is the factory setting.

**Electronic Ignition System**

- Slide the 3-position button on the remote receiver to the ON position. The spark electrode should begin sparking to ignite the pilot (the pilot may ignite after only one spark). After the pilot flame is lit, the main gas valve should open and the main gas flame should ignite.
- Slide the button to OFF. The main gas flame and pilot flame should BOTH extinguish.
- Slide the button to REMOTE (the center position).
- Then press the MODE button on the transmitter to change the system to ON. The spark electrode should begin sparking to ignite the pilot. After the pilot is lit, the main gas valve should open and the main gas flame should ignite.
- Press the MODE button on the transmitter to OFF. The main gas flame and pilot flame should BOTH extinguish.
- Press the MODE button on the transmitter to change the system to THERMO.
- Advance the SET temperature on the transmitter to temperature of at least 2° F (1° C) above the room temperature displayed on the LCD screen and the system flame will ignite.
- Set the SET temperature to at least 2° F (1° C) below the room temperature and the system will extinguish. Thereafter, it should continue to cycle on and off thermostatically approximately every two minutes as the ROOM temperature changes, but only when the temperature differential between ROOM and SET temperatures differ at least 2° F (1° C). The 2° F differential is the factory setting.

**Timer Operation**

The countdown timer will operate in either the manual ON or THERMO mode. Once the fireplace system is in an operating mode, set the countdown timer to turn off in 15 minutes. The timer function will allow operation to continue until the “countdown time” on the LCD screen expires. After 15 min. elapses, the system should turn off.

**Transmitter Wall Bracket**

The transmitter can be hung on a wall using the bracket provided. Locate the bracket on an inside wall sufficiently far away from direct sources of heat such as a fireplace, incandescent lighting, or sunlight so it detects ambient room temperatures, not a single heat source. If the bracket is installed on a solid wood wall, drill 1/8” pilot holes and install with the screws provided. If it is installed on a plaster/wallboard wall, first drill two 1/4” holes into the wall, then use a hammer to tap in the two plastic wall anchors flush with the wall, then install the screws provided.

**Battery Life**

Life expectancy of the batteries in the transmitter should be at least 12 months. Check batteries annually. When the transmitter no longer operates the remote receiver from a distance it did previously (i.e., the transmitter’s range has decreased) the batteries should be checked.

**Specifications**

Batteries: Transmitter - 3V 2 ea.; AAA 1.5V, Alkaline  
 Receiver - 110-120 VAC; 60Hz

**Service Parts List**

Description	Service Part Number	
	Compatible With Receiver Model RCT-MLT-II	Compatible With Receiver Model RCT-MLT-IV (UN110S24F RX)
Solenoid HI/LO	HTI-17-006	HTI-98-006
Transmitter Wall Holder	HTI-16-006	HTI-16-006
Batteries-Transmitter	HTI-14-006	HTI-14-006
Receiver	HTI-13-006	HTI-99-006
Transmitter (RCT-MLT-HNG)	HTI-12-006-HNG	HTI-12-006-HNG
Transmitter (RCT-MLT-HTL)	HTI-12-006-HTL	HTI-12-006-HTL
Transmitter (RCT-MLT-MAJ)	HTI-12-006-MAJ	HTI-12-006-MAJ
Hardware Package	HTI-11-006	HTI-11-006

**Limited Warranty**

This REMOTE CONTROL SYSTEM is warranted for 12 months from the date of purchase or installation to the original purchaser to be free from defects in materials and workmanship. Damage to the SYSTEM caused by accident, misuse, abuse, or installation error whether performed by a contractor, service company, or owner, is not covered by this warranty. Seller will not be responsible for labor charges and/or damage incurred in installation, repair, replacement or for incidental or consequential damages. Batteries and any damage caused by them are not covered by this warranty. Some states, provinces, and nations do not allow exclusion or limitations of incidental or consequential damages, so the above limitations or exclusions may not apply. This warranty gives you specific legal rights. You may have other rights that vary by state, province or nation.



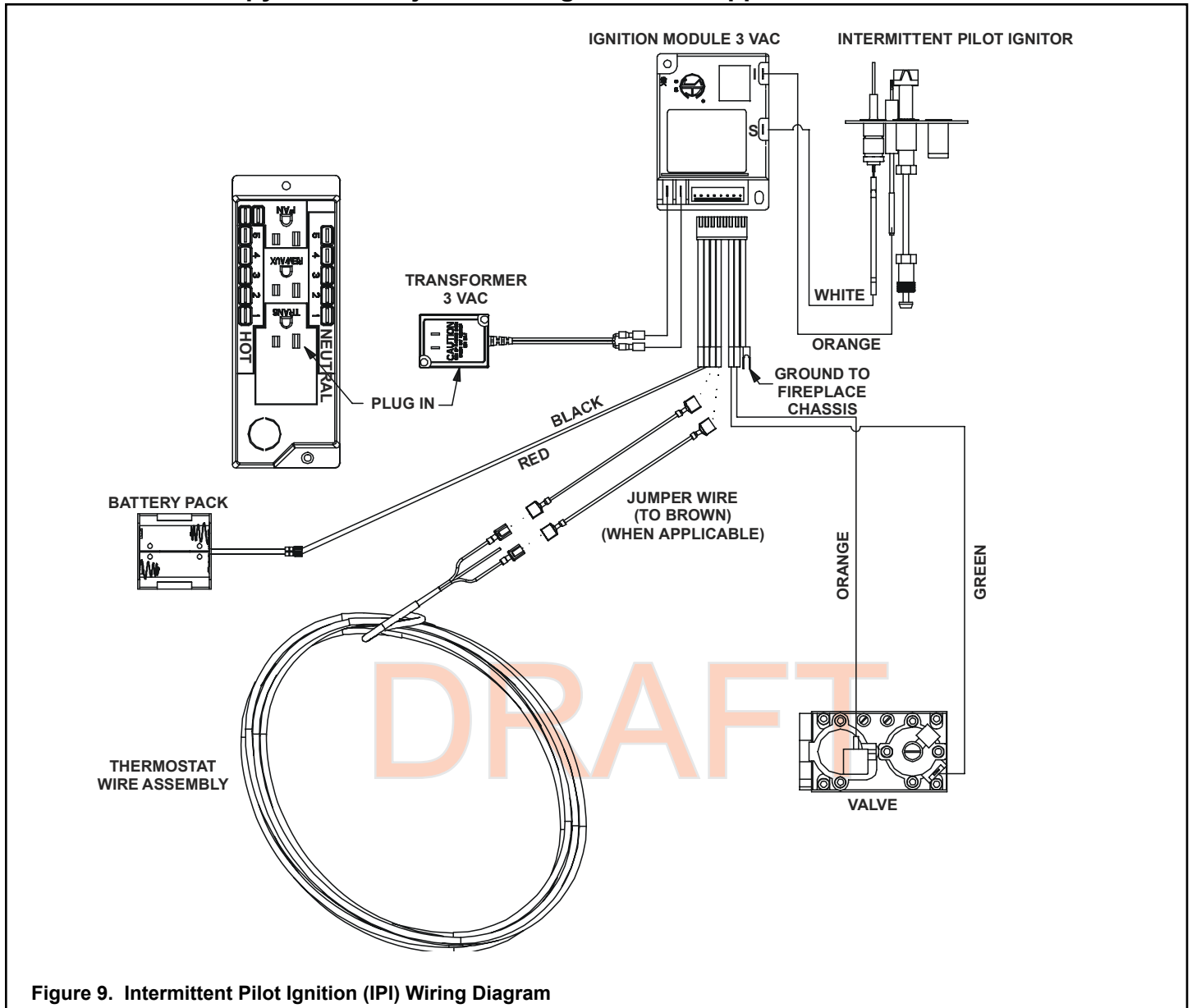

Figure 9. Intermittent Pilot Ignition (IPI) Wiring Diagram

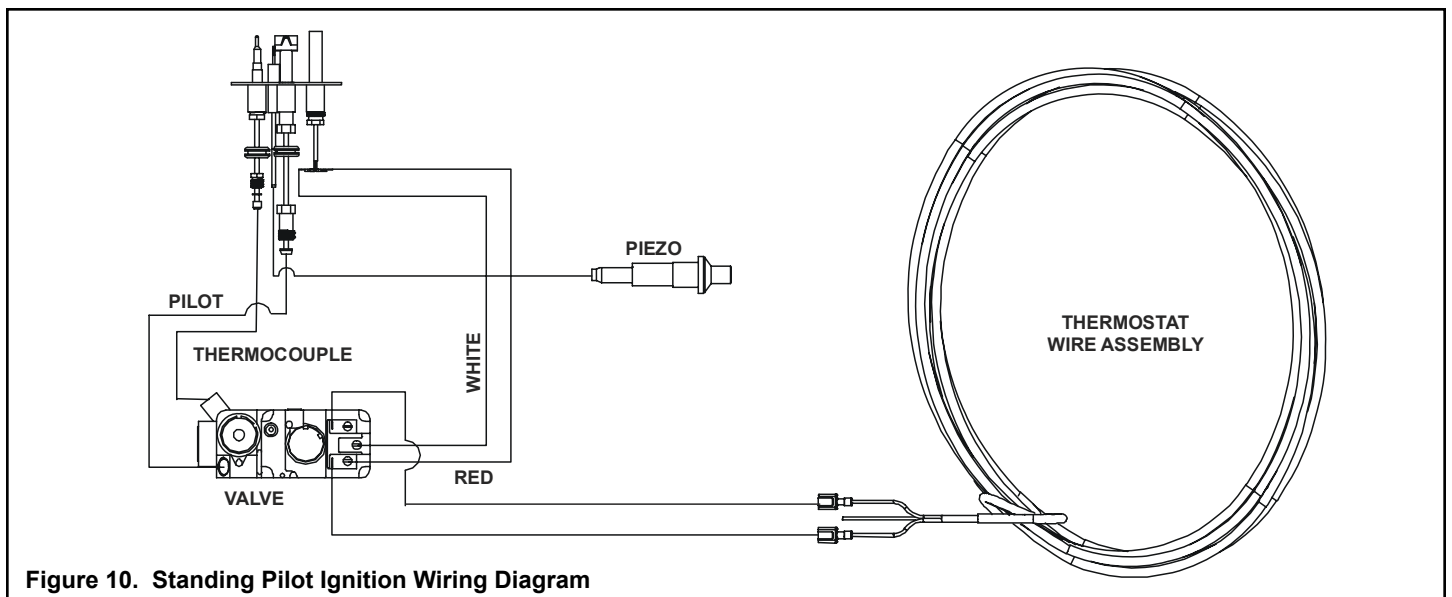

Figure 10. Standing Pilot Ignition Wiring Diagram

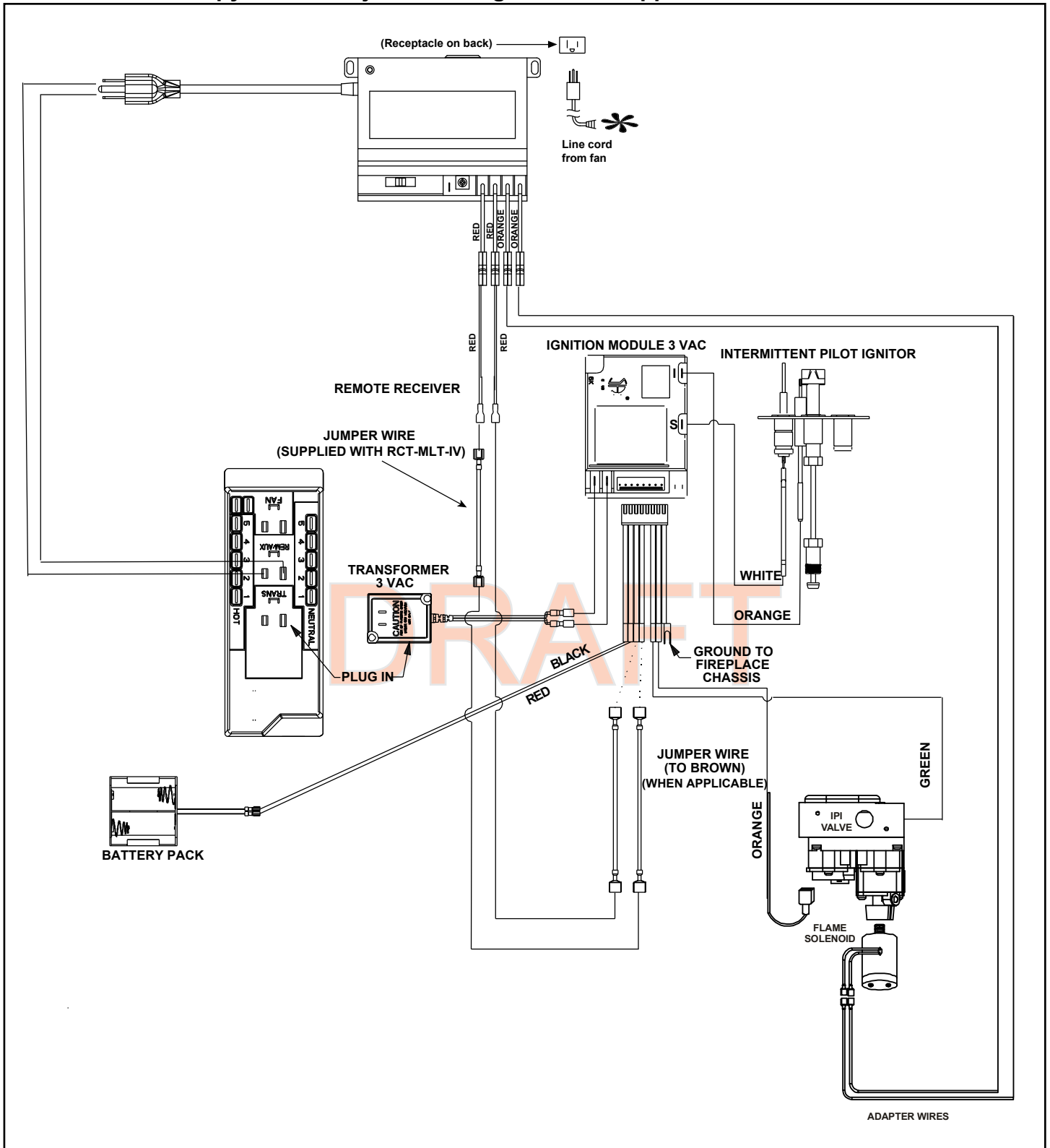

Figure 11. Remote Control Intermittent Pilot Ignition (IPI) Wiring Diagram

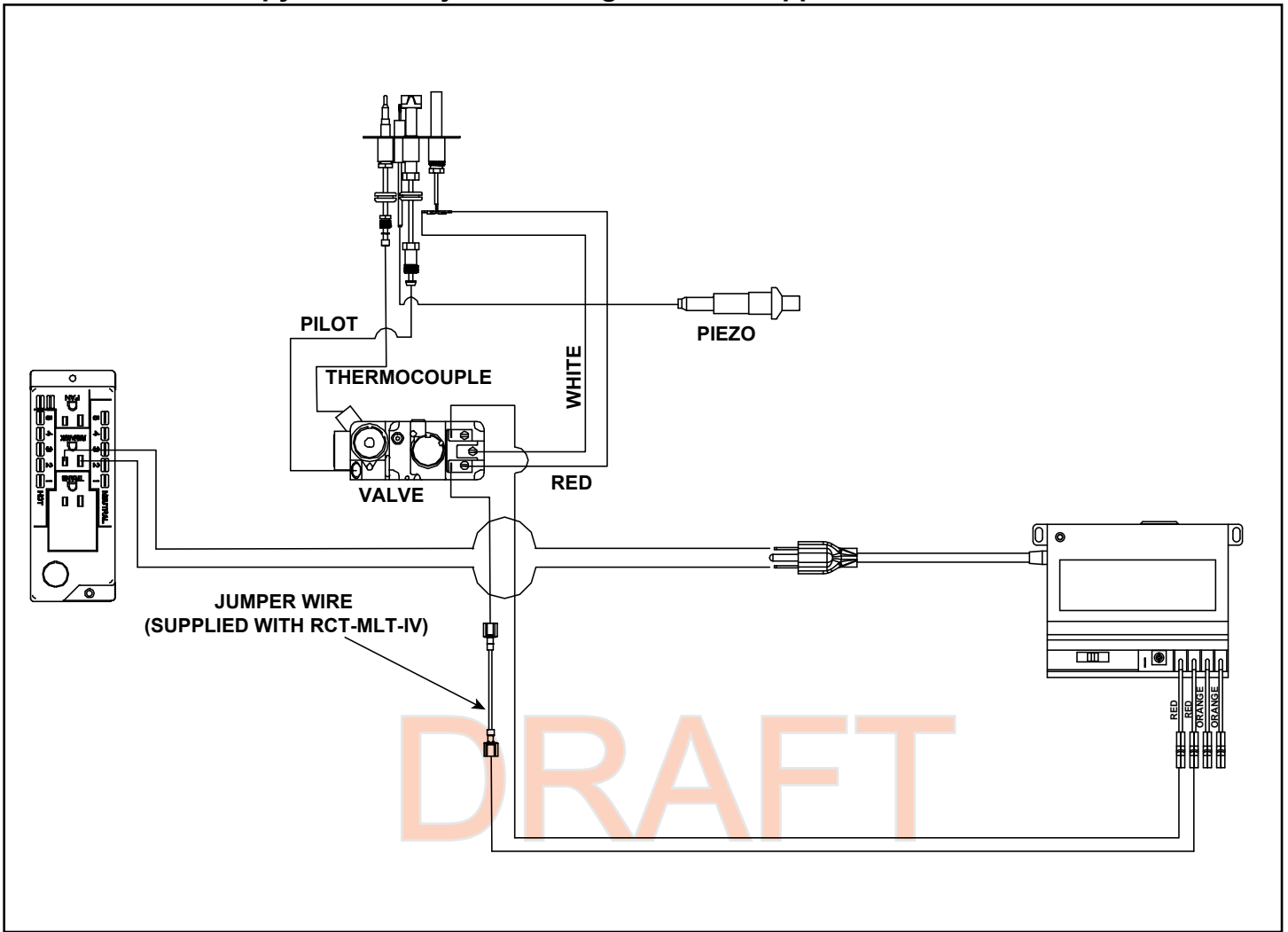

Figure 12. Remote Control Standing Pilot Ignition Wiring Diagram

Please contact your Hearth & Home Technologies dealer with any questions or concerns.  
For the location of your nearest  
Hearth & Home Technologies dealer,  
please visit [www.hearthnhome.com](http://www.hearthnhome.com).

Hearth & Home Technologies  
7571 215th Street West, Lakeville, MN 55044  
[www.hearthnhome.com](http://www.hearthnhome.com)