

7. RF Antenna conducted Spurious

Name of Test	RF Antenna Conducted Spurious
Base Standard	FCC 15.247(d)

Test Result: Complies
Measurement Data: See plots below

Method of Measurement:

Reference FCC document: KDB558074

The measurements were performed from 30 MHz to 25 GHz(for 2.4G) and 30 MHz to 40

Method of Measurement:

Reference FCC document: KDB558074

The measurements were performed from 30 MHz to 25 GHz RF antenna conducted per FCC 15.247 (d) was measured from the EUT antenna port using a 50 ohm spectrum analyzer with the resolution bandwidth set at 100 kHz, and the video bandwidth set at 100 kHz. Harmonics and spurious noise must be at least 20 dB down from the highest emission level within the authorized band as measured with a 100 kHz RBW. The table below is the results from the highest emission for each channel within the authorized band. This table was used to determine the spurious limits for each channel.

Test Diagram:

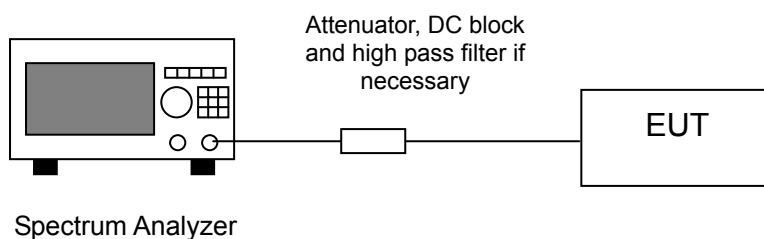

Chain 0: conducted spurious @ 802.11b mode channel 1

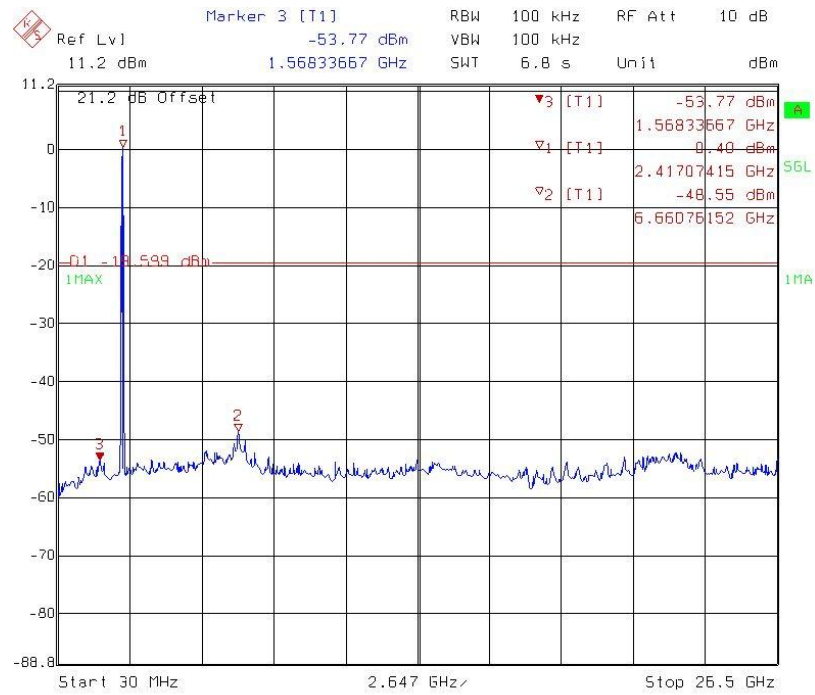

Title: Conducted Spurious.
Comment A: 11b 2412 ch1 Chain0
Date: 23.MAY 2011 15:22:52

Chain 0: conducted spurious @ 802.11b mode channel 6

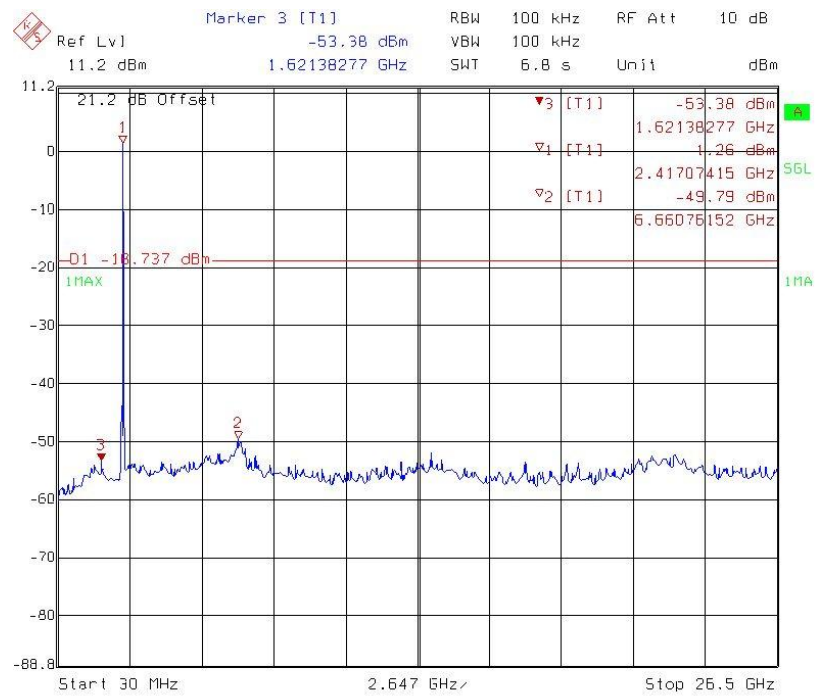

Title: Conducted Spurious.
Comment A: 11b 2437 ch6 Chain0
Date: 23.MAY 2011 15:26:53

Chain 0: conducted spurious @ 802.11b mode channel 11

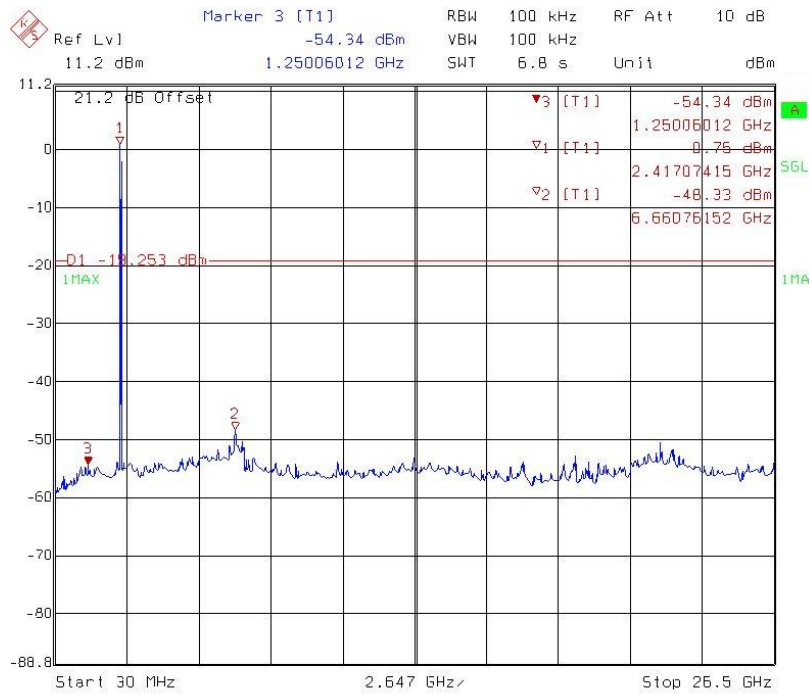

Title: Conducted Spurious.
Comment A: 11b 2452 ch11 Chain0
Date: 23.MAY 2011 15:30:04

Chain 0: conducted spurious @ 802.11g mode channel 1

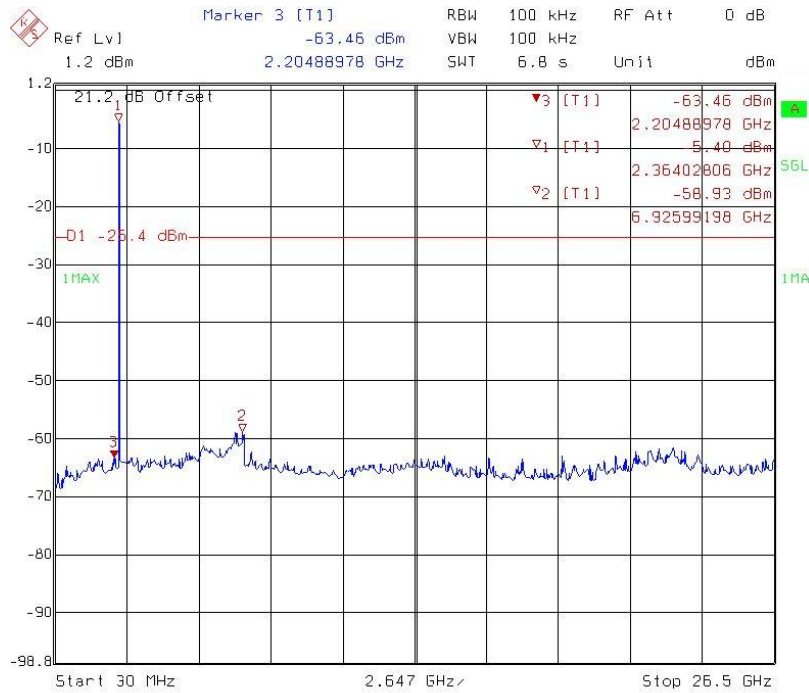

Title: Conducted Spurious.
Comment A: 11g 2412 ch1 Chain0
Date: 23.MAY 2011 15:34:18

Chain 0: conducted spurious @ 802.11g mode channel 6

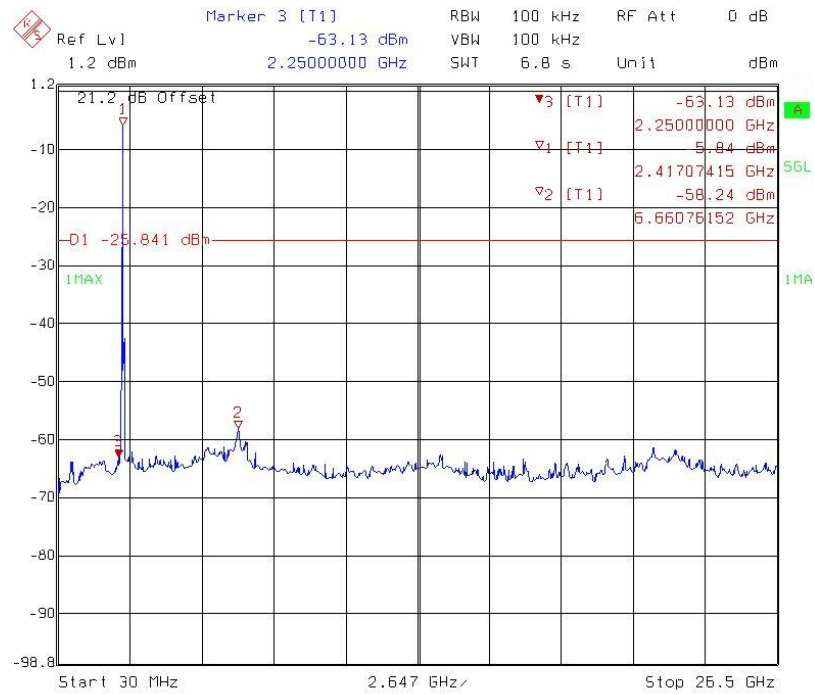

Title: Conducted Spurious.
Comment A: 11g 2437 ch6 Chain0
Date: 23.MAY 2011 15:37:07

Chain 0: conducted spurious @ 802.11g mode channel 11

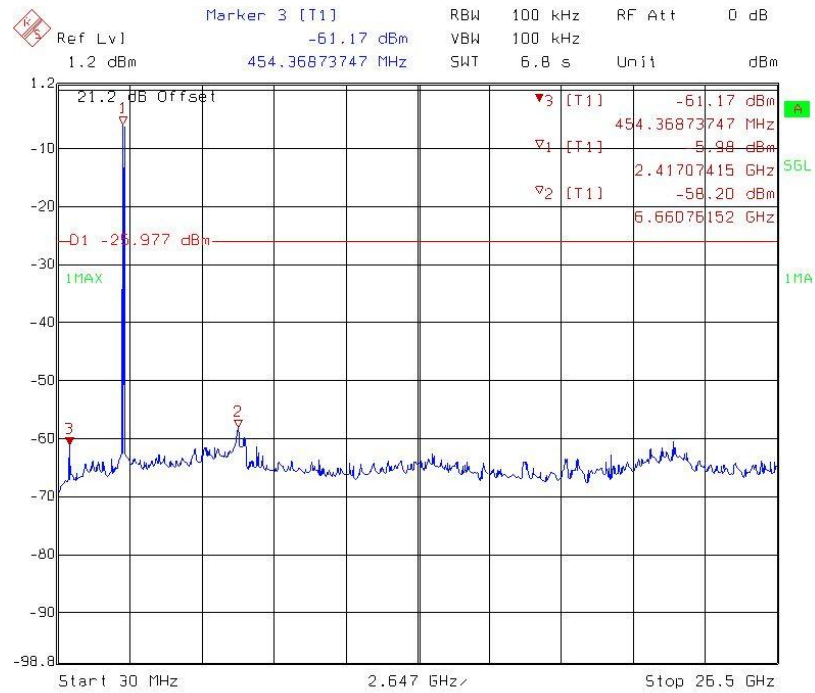

Title: Conducted Spurious.
Comment A: 11g 2462 ch11 Chain0
Date: 23.MAY 2011 15:39:49

Chain 0: conducted spurious @ 802.11n HT20 mode channel 1

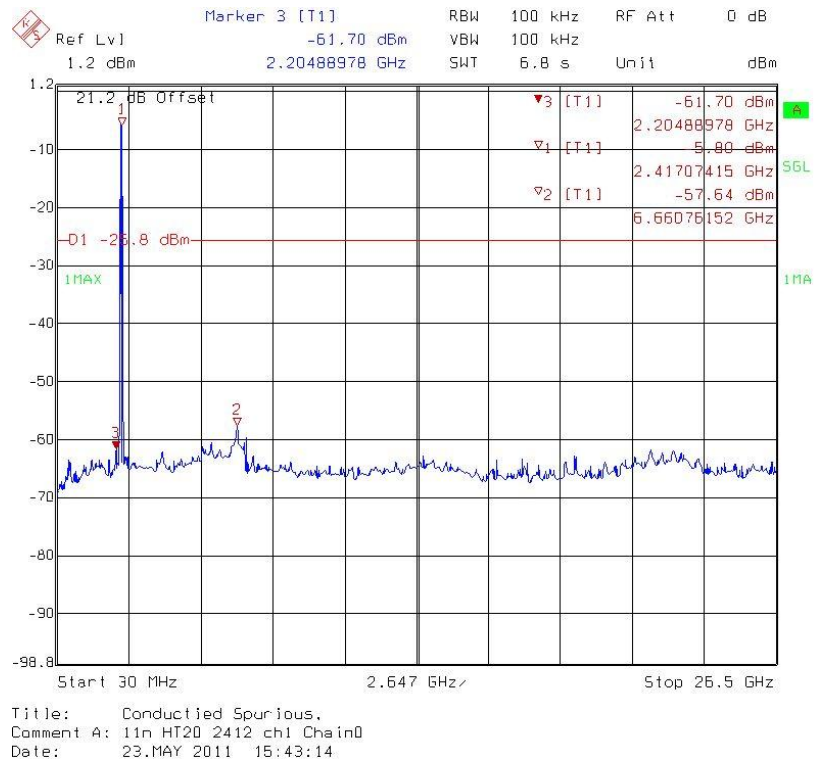

Chain 0: conducted spurious @ 802.11n HT20 mode channel 6

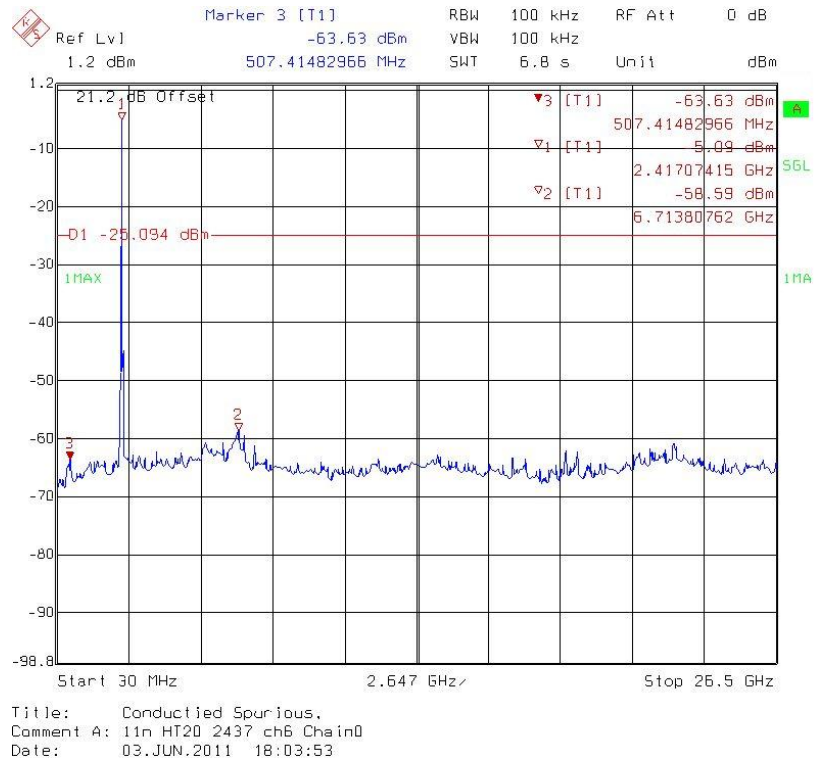

Chain 0: conducted spurious @ 802.11n HT20 mode channel 11

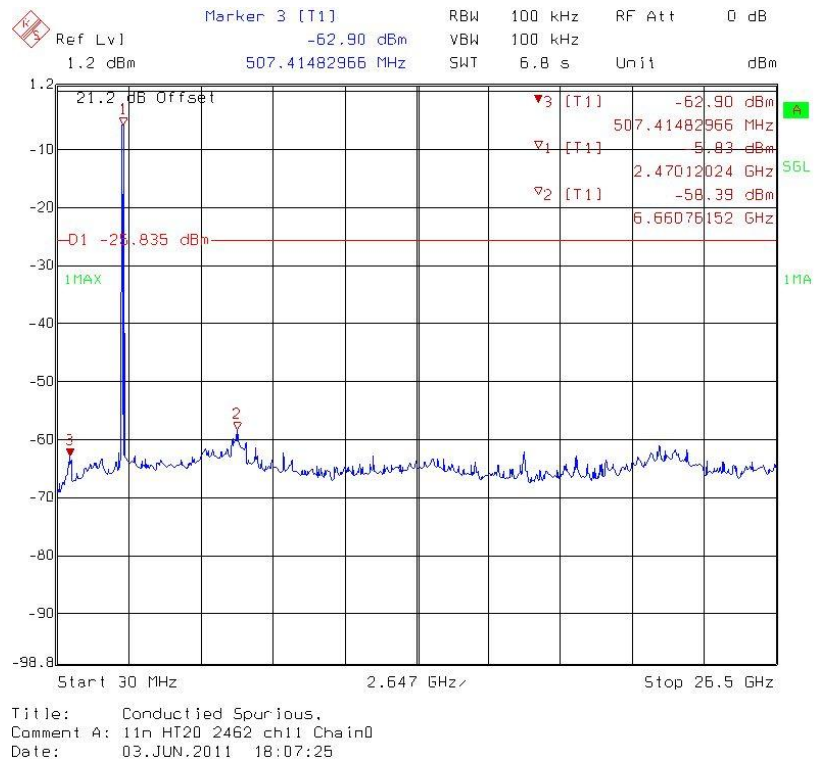

Chain 0: conducted spurious @ 802.11n HT40 mode channel 3

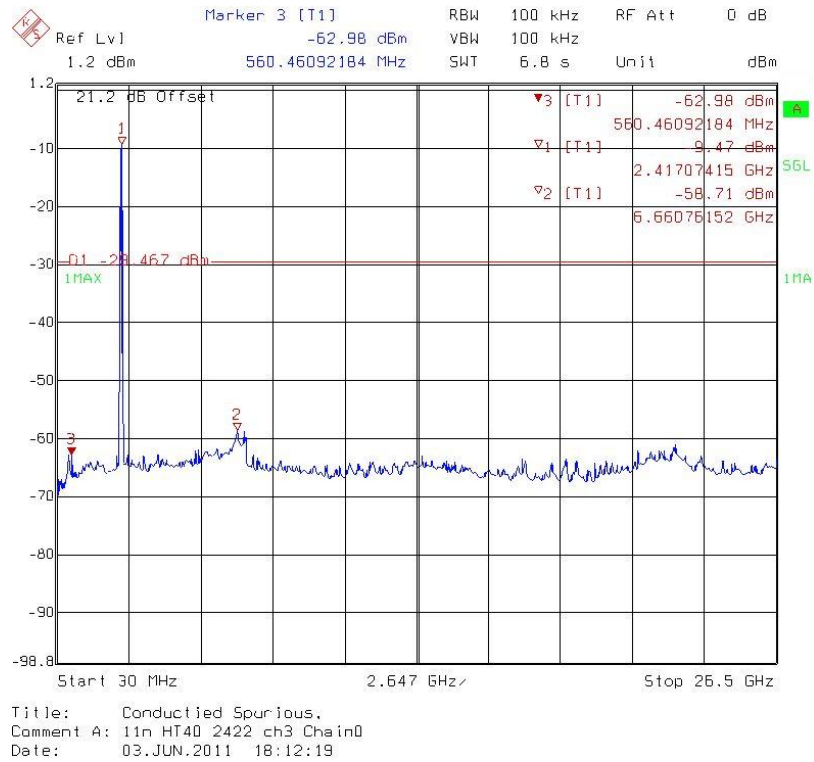

Chain 0: conducted spurious @ 802.11n HT40 mode channel 6

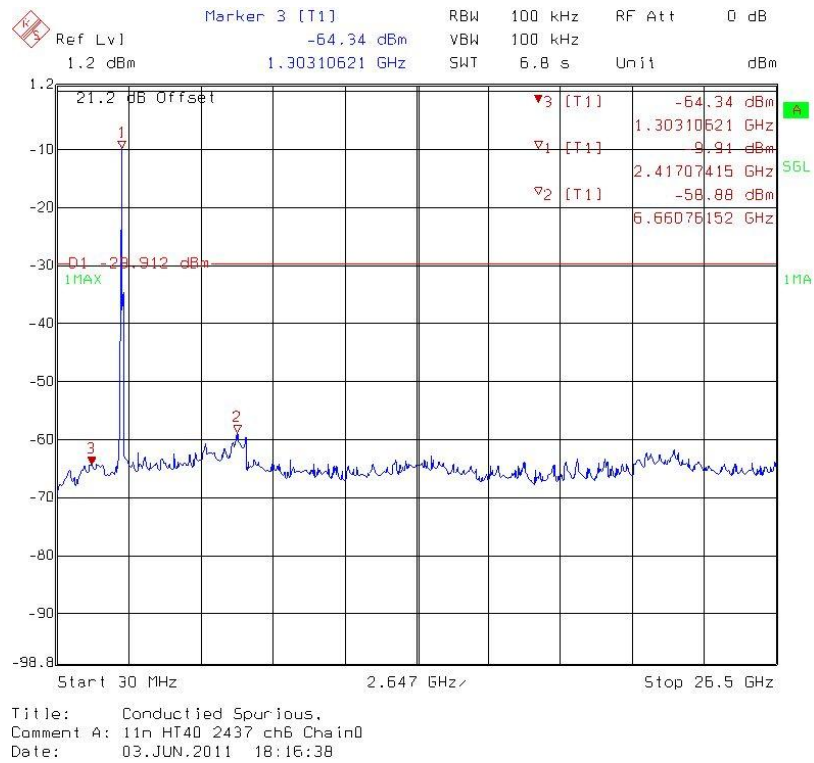

Chain 0: conducted spurious @ 802.11n HT40 mode channel 9

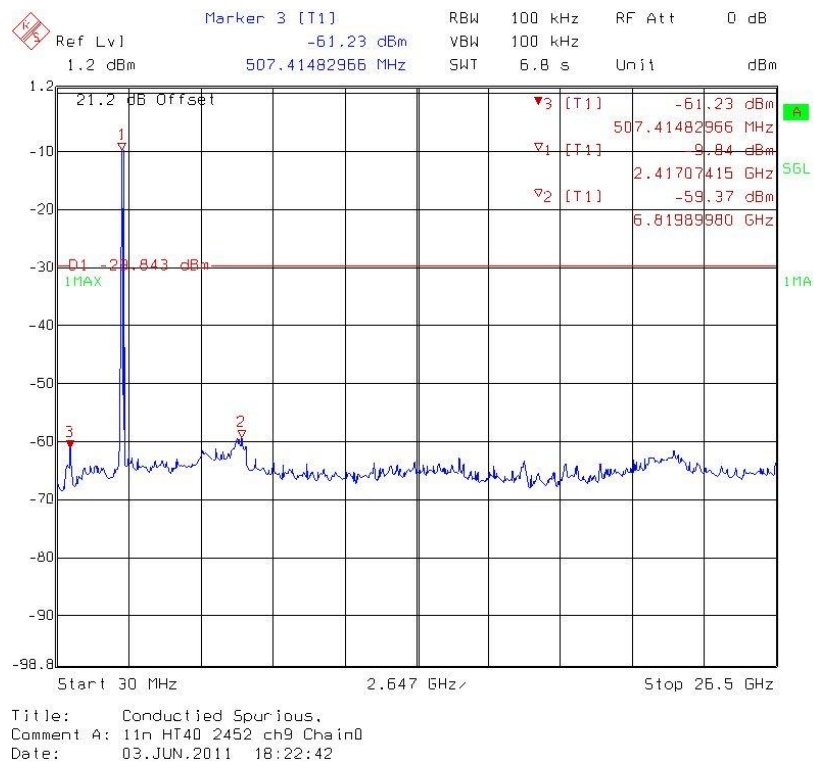

8. Radiated Spurious Emission

Name of Test	Radiated Spurious Emission
Base Standard	FCC 15.247(d), 15.209, 15.205

Test Result: Complies
Measurement Data: See Tables below

Method of Measurement:

Reference FCC document: KDB558074, ANSI C63.4

The frequency range from 30 MHz to 1000 MHz using Bilog Antenna.
The frequency range over 1 GHz using Horn Antenna.

Radiated emissions were investigated cover the frequency range from 30 MHz to 1000 MHz using a receiver RBW of 120 kHz record QP reading, and the frequency over 1 GHz using a spectrum analyzer RBW of 1 MHz and 10 Hz VBW record Average reading. (15.209 paragraph), the Peak reading (1 MHz RBW/VBW) recorded also on the report. The EUT for testing is arranged on a wooden turntable. If some peripherals apply to the EUT, the peripherals will be connected to EUT and the whole system. During the test, all cables were arranged to produce worst-case emissions. The signal is maximized through rotation. The height of antenna and polarization is changing constantly for exploring for maximum signal level. The height of antenna can be up to 4 meters and down to 1 meter. The measurement for radiated emission will be done at the distance of three meters unless the signal level is too low to measure at that distance. In the case of the reading under noise floor, a pre-amplifier is used and/or the test is conducted at a closer distance. And then all readings are extrapolated back to the equivalent 3 meters reading using inverse scaling with distance.

The EUT configuration please refer to the “Spurious set-up photo.pdf”.

Test Diagram:

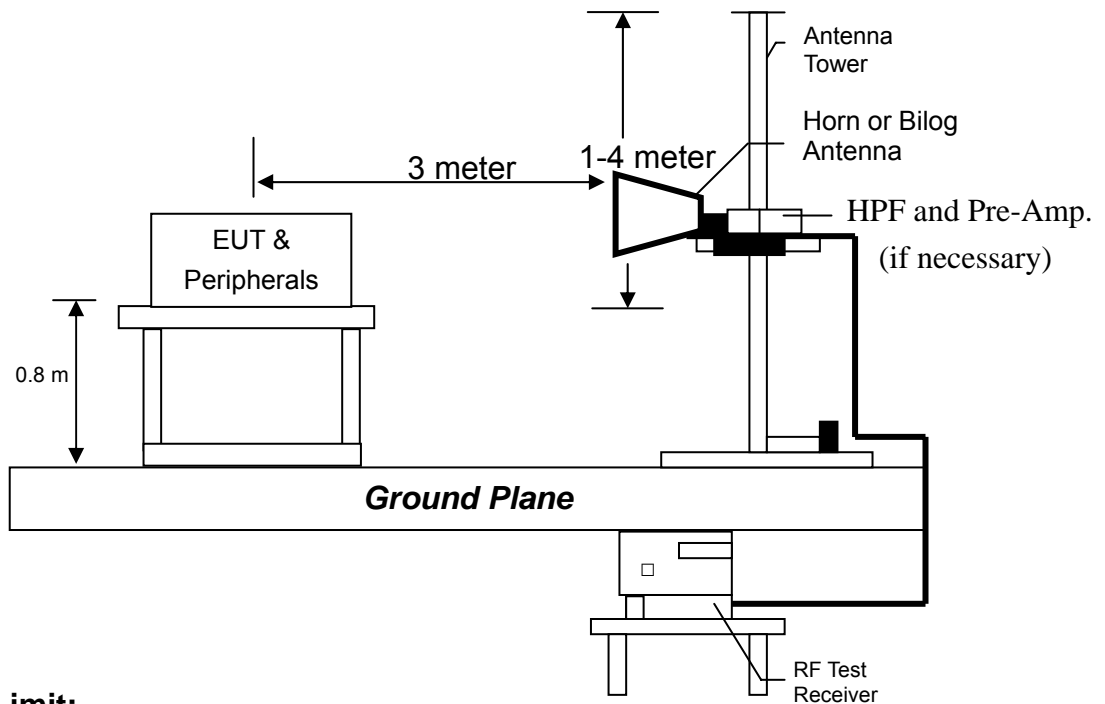

Emission Limit:

The spurious Emission shall test through the 10th harmonic. In addition, radiated emissions which fall in the restricted bands, as defined in §15.205(a), must also comply with the radiated emission limits specified in §15.209(a).

Frequency (MHz)	Limits (dBµV/m@ 3 meter)
30-88	40
88-216	43.5
216-960	46
Above 960	54

Remark:

1. In the above table, the tighter limit applies at the band edges.
2. Distance refers to the distance in meters between the measuring instrument antenna and the closed point of any part of the device or system

- Note:**
- (1) The EUT was tested while in a continuous transmit mode and the worst case data rates are Mbps data rate for 802.11b mode, 6 Mbps data rate for 802.11g mode, 6.5 Mbps data rate for 802.11n HT20 mode and 13 Mbps data rate for 802.11n HT40 mode. The EUT was tuned to a low, middle and high channel.
 - (2) The EUT operating at 2.4 GHz ISM band. Frequency Range scanned from 30 MHz to 25 GHz.

Measurement results: frequencies equal to or less than 1 GHz

The test was performed on EUT under 802.11b, 802.11g, 802.11n HT20 and 802.11n HT40 mode. The worst case occurred at 802.11b Tx channel 1.

EUT : WiFiHU-c-2-NE
Worst Case : 802.11b Tx at channel 1

Antenna Polariz. (V/H)	Freq. (MHz)	Receiver Detector	Corr. Factor (dB/m)	Reading (dBuV)	Corrected Level (dBuV/m)	Limit @ 3 m (dBuV/m)	Margin (dB)
V	30.60	QP	12.60	25.23	37.82	40.00	-2.18
V	58.13	QP	12.90	19.56	32.45	40.00	-7.55
V	94.99	QP	7.38	29.75	37.12	43.50	-6.38
V	107.60	QP	7.64	30.88	38.52	43.50	-4.98
V	249.22	QP	12.22	24.19	36.40	46.00	-9.60
V	878.75	QP	24.35	13.25	37.59	46.00	-8.41
H	94.99	QP	7.93	30.85	38.77	43.50	-4.73
H	165.80	QP	13.84	23.99	37.82	43.50	-5.68
H	199.75	QP	11.27	25.69	36.95	43.50	-6.55
H	249.22	QP	12.36	26.91	39.27	46.00	-6.73
H	480.08	QP	18.64	17.81	36.45	46.00	-9.55
H	854.50	QP	24.12	14.09	38.20	46.00	-7.80

Remark:

1. Corr. Factor = Antenna Factor + Cable Loss
2. Corrected Level = Reading + Corr. Factor

Measurement results: frequency above 1GHz

EUT : WiFiHU-c-2-NE
Test Condition : 802.11b Tx at channel 1

Frequency (MHz)	Spectrum Analyzer Detector	Antenna Polariz. (H/V)	Preamp. Gain (dB)	Correction Factor (dB/m)	Reading (dBuV)	Corrected Level (dBuV/m)	Limit @ 3 m (dBuV/m)	Margin (dB)
4824	PK	V	35.10	38.54	50.84	54.28	74	-19.72
4824	AV	V	35.10	38.54	48.76	52.20	54	-1.80
7236	PK	V	33.00	44.60	36.48	48.08	54	-5.92
4824	PK	H	35.10	38.54	47.96	51.40	54	-2.60
7236	PK	H	33.00	44.60	37.71	49.31	54	-4.69

Remark:

1. Correction Factor = Antenna Factor + Cable Loss
2. Corrected Level = Reading + Correction Factor – Preamp. Gain
3. The frequency measured ranges from 1 GHz to 25 GHz.The data value listed above which is higher than the system noise floor.

EUT : WiFiHU-c-2-NE
Test Condition : 802.11b Tx at channel 6

Frequency (MHz)	Spectrum Analyzer Detector	Antenna Polariz. (H/V)	Preamp. Gain (dB)	Correction Factor (dB/m)	Reading (dBuV)	Corrected Level (dBuV/m)	Limit @ 3 m (dBuV/m)	Margin (dB)
4874	PK	V	35.10	38.54	50.48	53.92	74	-20.08
4874	AV	V	35.10	38.54	49.15	52.59	54	-1.41
7311	PK	V	33.00	44.60	37.34	48.94	54	-5.06
4874	PK	H	35.10	38.54	45.99	49.43	54	-4.57
7311	PK	H	33.00	44.60	34.92	46.52	54	-7.48

Remark:

1. Correction Factor = Antenna Factor + Cable Loss
2. Corrected Level = Reading + Correction Factor – Preamp. Gain
3. The frequency measured ranges from 1 GHz to 25 GHz.The data value listed above which is higher than the system noise floor.

EUT : WiFiHU-c-2-NE
Test Condition : 802.11b Tx at channel 11

Frequency (MHz)	Spectrum Analyzer Detector	Antenna Polariz. (H/V)	Preamp. Gain (dB)	Correction Factor (dB/m)	Reading (dBuV)	Corrected Level (dBuV/m)	Limit @ 3 m (dBuV/m)	Margin (dB)
4924	PK	V	35.10	38.54	51.79	55.23	74	-18.77
4924	AV	V	35.10	38.54	50.00	53.44	54	-0.56
7386	PK	V	33.00	44.60	38.90	50.50	54	-3.50
4924	PK	H	35.10	38.54	45.70	49.14	54	-4.86
7386	PK	H	33.00	44.60	33.93	45.53	54	-8.47

Remark:

1. Correction Factor = Antenna Factor + Cable Loss
2. Corrected Level = Reading + Correction Factor – Preamp. Gain
3. The frequency measured ranges from 1GHz to 25GHz. The data value listed above which is higher than the system noise floor.

EUT : WiFiHU-c-2-NE
Test Condition : 802.11g Tx at channel 1

Frequency (MHz)	Spectrum Analyzer Detector	Antenna Polariz. (H/V)	Preamp. Gain (dB)	Correction Factor (dB/m)	Reading (dBuV)	Corrected Level (dBuV/m)	Limit @ 3 m (dBuV/m)	Margin (dB)
4824	PK	V	35.10	38.54	43.10	46.54	54	-7.46
7236	PK	V	33.00	44.60	34.53	46.13	54	-7.87
4824	PK	H	35.10	38.54	43.67	47.11	54	-6.89

Remark:

1. Correction Factor = Antenna Factor + Cable Loss
2. Corrected Level = Reading + Correction Factor – Preamp. Gain
3. The frequency measured ranges from 1 GHz to 25 GHz. The data value listed above which is higher than the system noise floor.

EUT : WiFiHU-c-2-NE
Test Condition : 802.11g Tx at channel 6

Frequency (MHz)	Spectrum Analyzer Detector	Antenna Polariz. (H/V)	Preamp. Gain (dB)	Correction Factor (dB/m)	Reading (dBuV)	Corrected Level (dBuV/m)	Limit @ 3 m (dBuV/m)	Margin (dB)
4874	PK	V	35.10	38.54	45.17	48.61	54	-5.39
7311	PK	V	33.00	44.60	35.71	47.31	54	-6.69
4874	PK	H	35.10	38.54	41.77	45.21	54	-8.79
7311	PK	H	33.00	44.60	35.14	46.74	54	-7.26

Remark:

1. Correction Factor = Antenna Factor + Cable Loss
2. Corrected Level = Reading + Correction Factor – Preamp. Gain
3. The frequency measured ranges from 1 GHz to 25 GHz.The data value listed above which is higher than the system noise floor.

EUT : WiFiHU-c-2-NE
Test Condition : 802.11g Tx at channel 11

Frequency (MHz)	Spectrum Analyzer Detector	Antenna Polariz. (H/V)	Preamp. Gain (dB)	Correction Factor (dB/m)	Reading (dBuV)	Corrected Level (dBuV/m)	Limit @ 3 m (dBuV/m)	Margin (dB)
4924	PK	V	35.10	38.54	45.18	48.62	54	-5.38
7386	PK	V	33.00	44.60	39.56	51.16	54	-2.84
4924	PK	H	35.10	38.54	39.56	43.00	54	-11.00
7386	PK	H	33.00	44.60	35.34	46.94	54	-7.06

Remark:

1. Correction Factor = Antenna Factor + Cable Loss
2. Corrected Level = Reading + Correction Factor – Preamp. Gain
3. The frequency measured ranges from 1 GHz to 25 GHz.The data value listed above which is higher than the system noise floor.

EUT : WiFiHU-c-2-NE
Test Condition : 802.11n HT20 Tx at channel 1

Frequency (MHz)	Spectrum Analyzer Detector	Antenna Polariz. (H/V)	Preamp. Gain (dB)	Correction Factor (dB/m)	Reading (dBuV)	Corrected Level (dBuV/m)	Limit @ 3 m (dBuV/m)	Margin (dB)
4824	PK	V	35.10	38.54	43.41	46.85	54	-7.15
7236	PK	V	33.00	44.60	36.39	47.99	54	-6.01
4824	PK	H	35.10	38.54	40.75	44.19	54	-9.81
7236	PK	H	33.00	44.60	34.48	46.08	54	-7.92

Remark:

1. Correction Factor = Antenna Factor + Cable Loss
2. Corrected Level = Reading + Correction Factor – Preamp. Gain
3. The frequency measured ranges from 1 GHz to 25 GHz.The data value listed above which is higher than the system noise floor.

EUT : WiFiHU-c-2-NE
Test Condition : 802.11n HT20 Tx at channel 6

Frequency (MHz)	Spectrum Analyzer Detector	Antenna Polariz. (H/V)	Preamp. Gain (dB)	Correction Factor (dB/m)	Reading (dBuV)	Corrected Level (dBuV/m)	Limit @ 3 m (dBuV/m)	Margin (dB)
4874	PK	V	35.10	38.54	46.98	50.42	54	-3.58
7311	PK	V	33.00	44.60	36.53	48.13	54	-5.87
4874	PK	H	35.10	38.54	42.38	45.82	54	-8.18
7311	PK	H	33.00	44.60	35.32	46.92	54	-7.08

Remark:

1. Correction Factor = Antenna Factor + Cable Loss
2. Corrected Level = Reading + Correction Factor – Preamp. Gain
3. The frequency measured ranges from 1 GHz to 25 GHz.The data value listed above which is higher than the system noise floor.

EUT : WiFiHU-c-2-NE
Test Condition : 802.11n HT20 Tx at channel 11

Frequency (MHz)	Spectrum Analyzer Detector	Antenna Polariz. (H/V)	Preamp. Gain (dB)	Correction Factor (dB/m)	Reading (dBuV)	Corrected Level (dBuV/m)	Limit @ 3 m (dBuV/m)	Margin (dB)
4924	PK	V	35.10	38.54	45.12	48.56	54	-5.44
7386	PK	V	33.00	44.60	40.40	52.00	54	-2.00
4924	PK	H	35.10	38.54	42.53	45.97	54	-8.03
7386	PK	H	33.00	44.60	34.29	45.89	54	-8.11

Remark:

1. Correction Factor = Antenna Factor + Cable Loss
2. Corrected Level = Reading + Correction Factor – Preamp. Gain
3. The frequency measured ranges from 1 GHz to 25 GHz. The data value listed above which is higher than the system noise floor.

EUT : WiFiHU-c-2-NE
Test Condition : 802.11n HT40 Tx at channel 3

Frequency (MHz)	Spectrum Analyzer Detector	Antenna Polariz. (H/V)	Preamp. Gain (dB)	Correction Factor (dB/m)	Reading (dBuV)	Corrected Level (dBuV/m)	Limit @ 3 m (dBuV/m)	Margin (dB)
4844	PK	V	35.10	38.54	41.52	44.96	54	-9.04
7266	PK	V	33.00	44.60	33.86	45.46	54	-8.54
4844	PK	H	35.10	38.54	39.64	43.08	54	-10.92

Remark:

1. Correction Factor = Antenna Factor + Cable Loss
2. Corrected Level = Reading + Correction Factor – Preamp. Gain
3. The frequency measured ranges from 1 GHz to 25 GHz. The data value listed above which is higher than the system noise floor.

EUT : WiFiHU-c-2-NE
Test Condition : 802.11n HT40 Tx at channel 6

Frequency (MHz)	Spectrum Analyzer Detector	Antenna Polariz. (H/V)	Preamp. Gain (dB)	Correction Factor (dB/m)	Reading (dBUV)	Corrected Level (dBUV/m)	Limit @ 3 m (dBUV/m)	Margin (dB)
4874	PK	V	35.10	38.54	41.68	45.12	54	-8.88
7311	PK	V	33.00	44.60	34.89	46.49	54	-7.51
4874	PK	H	35.10	38.54	37.99	41.43	54	-12.57
7311	PK	H	33.00	44.60	34.63	46.23	54	-7.77

Remark:

1. Correction Factor = Antenna Factor + Cable Loss
2. Corrected Level = Reading + Correction Factor – Preamp. Gain
3. The frequency measured ranges from 1 GHz to 25 GHz.The data value listed above which is higher than the system noise floor.

EUT : WiFiHU-c-2-NE
Test Condition : 802.11n HT40 Tx at channel 9

Frequency (MHz)	Spectrum Analyzer Detector	Antenna Polariz. (H/V)	Preamp. Gain (dB)	Correction Factor (dB/m)	Reading (dBUV)	Corrected Level (dBUV/m)	Limit @ 3 m (dBUV/m)	Margin (dB)
4904	PK	V	35.10	38.54	41.74	45.18	54	-8.82
7356	PK	V	33.00	44.60	35.54	47.14	54	-6.86
4904	PK	H	35.10	38.54	38.01	41.45	54	-12.55

Remark:

1. Correction Factor = Antenna Factor + Cable Loss
2. Corrected Level = Reading + Correction Factor – Preamp. Gain
3. The frequency measured ranges from 1 GHz to 25 GHz.The data value listed above which is higher than the system noise floor.

9. Emission on Band Edge

Name of Test	Emission Band Edge
Base Standard	FCC 15.247(d)

Test Result: Complies
Measurement Data: See Tables & plots below

Method of Measurement:

Reference FCC document: KDB558074, ANSI C63.4

The frequency range from 30 MHz to 1000 MHz using Bilog Antenna.
 The frequency range over 1 GHz using Horn Antenna.

Radiated emissions were investigated cover the frequency range from 30 MHz to 1000 MHz using a receiver RBW of 120 kHz record QP reading, and the frequency over 1 GHz using a spectrum analyzer RBW of 1 MHz and 10 Hz VBW record Average reading. (15.209 paragraph), the Peak reading (1 MHz RBW/VBW) recorded also on the report.

Test Mode: 802.11b mode

Channel	Measurement Freq.Band (MHz)	Detector	The Max. Field Strength in Restrict Band (dBuV/m)	Limit @ 3 m (dBuV/m)	Margin (dB)
1 (lowest)	2310-2390	PK	58.49	74	-15.51
		AV	48.92	54	-5.08
11 (highest)	2483.5-2500	PK	59.40	74	-14.60
		AV	49.62	54	-4.38

Test Mode: 802.11g mode

Channel	Measurement Freq.Band (MHz)	Detector	The Max. Field Strength in Restrict Band (dBuV/m)	Limit @ 3 m (dBuV/m)	Margin (dB)
1 (lowest)	2310-2390	PK	61.38	74	-12.62
		AV	48.24	54	-5.76
11 (highest)	2483.5-2500	PK	62.26	74	-11.74
		AV	49.42	54	-4.58

Test Mode: 802.11n HT20 mode

Channel	Measurement Freq.Band (MHz)	Detector	The Max. Field Strength in Restrict Band (dBuV/m)	Limit @ 3 m (dBuV/m)	Margin (dB)
1 (lowest)	2310-2390	PK	62.69	74	-11.31
		AV	48.70	54	-5.30
11 (highest)	2483.5-2500	PK	65.72	74	-8.28
		AV	49.99	54	-4.01

Test Mode: 802.11n HT40 mode

Channel	Measurement Freq.Band (MHz)	Detector	The Max. Field Strength in Restrict Band (dBuV/m)	Limit @ 3 m (dBuV/m)	Margin (dB)
3 (lowest)	2310-2390	PK	65.01	74	-8.99
		AV	50.32	54	-3.68
9 (highest)	2483.5-2500	PK	62.20	74	-11.80
		AV	48.40	54	-5.60

Band edge @ 802.11b mode channel 1 (PK)

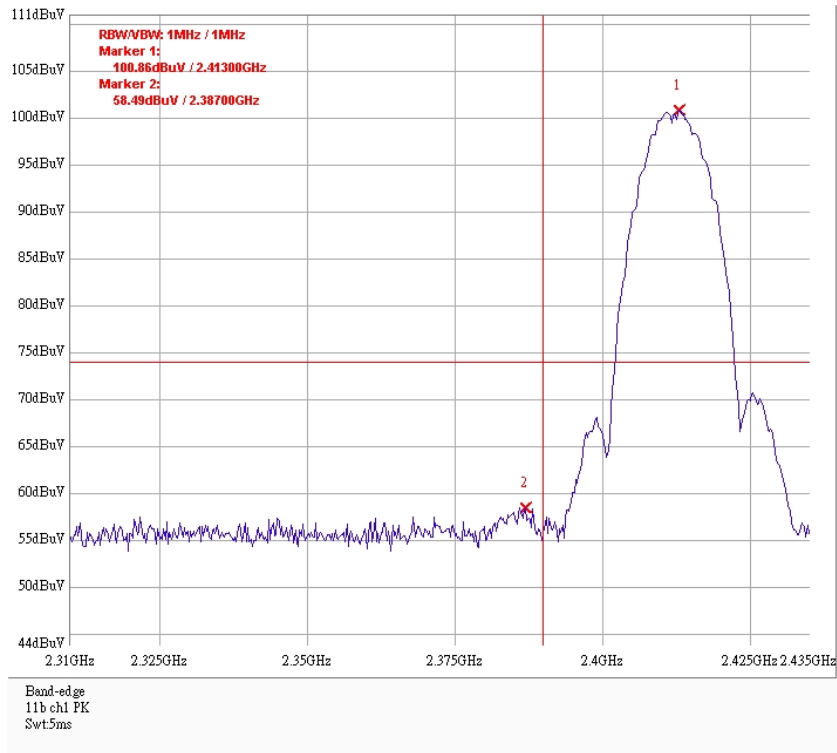

Band edge @ 802.11b mode channel 1 (AV)

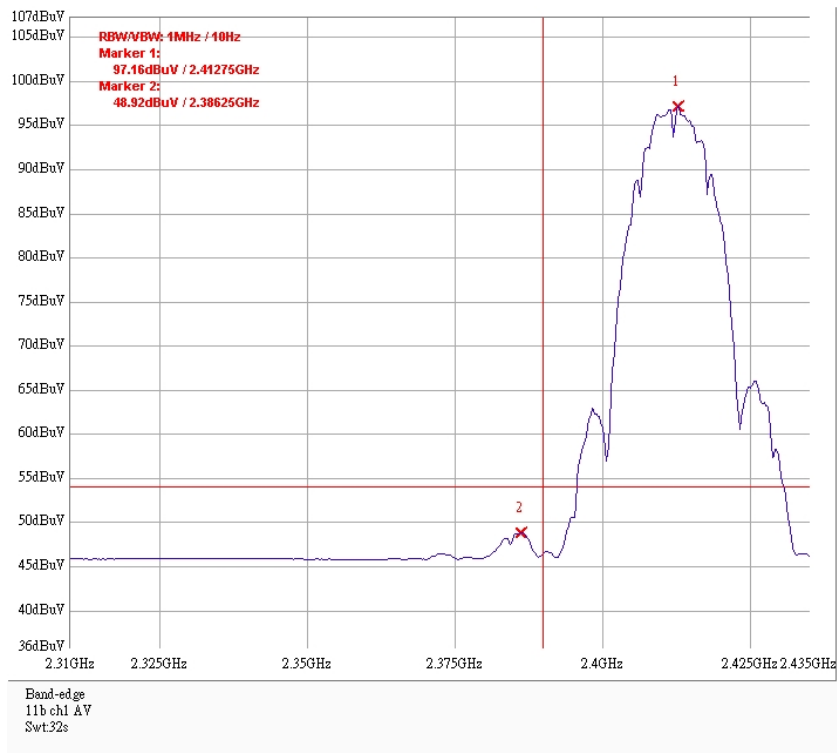

Band edge @ 802.11b mode channel 11 (PK)

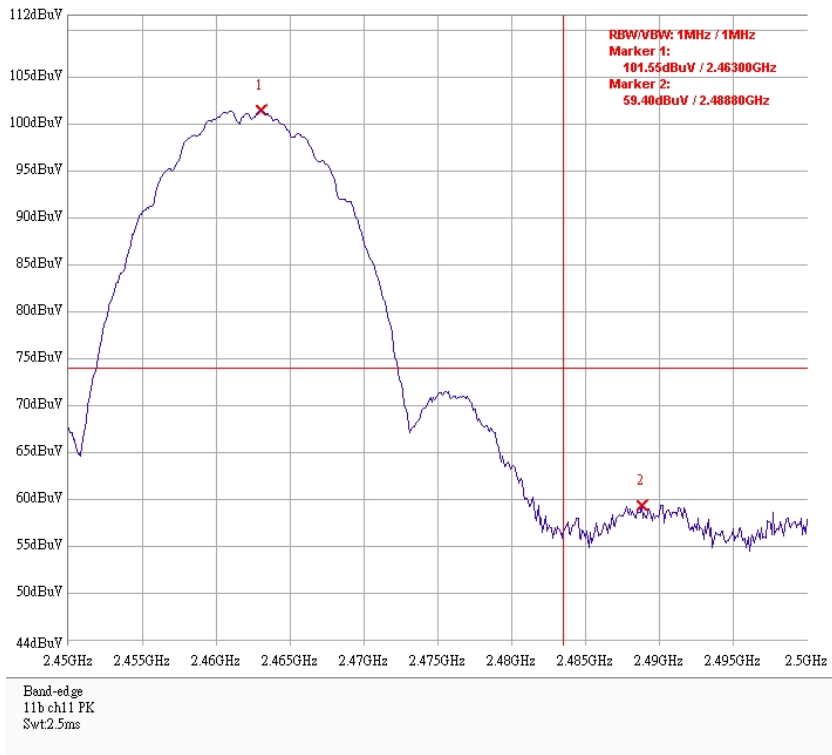

Band edge @ 802.11b mode channel 11 (AV)

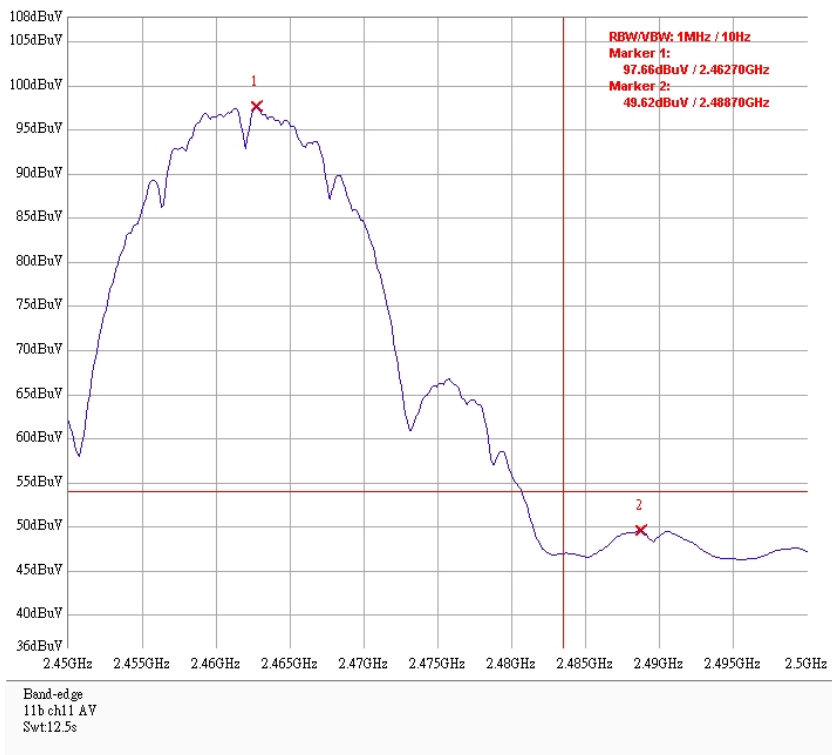

Band edge @ 802.11g mode channel 1 (PK)

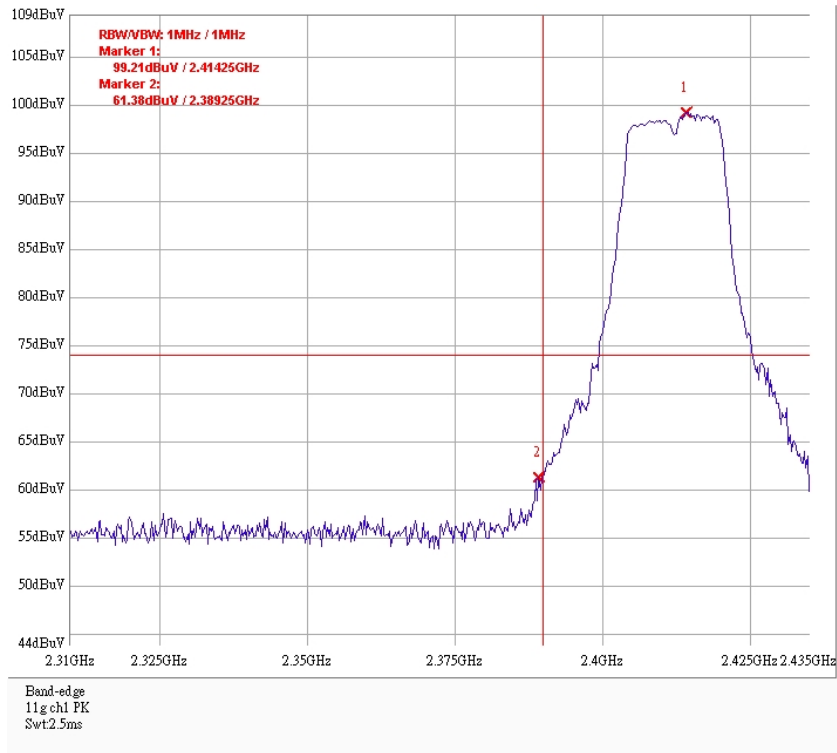

Band edge @ 802.11g mode channel 1 (AV)

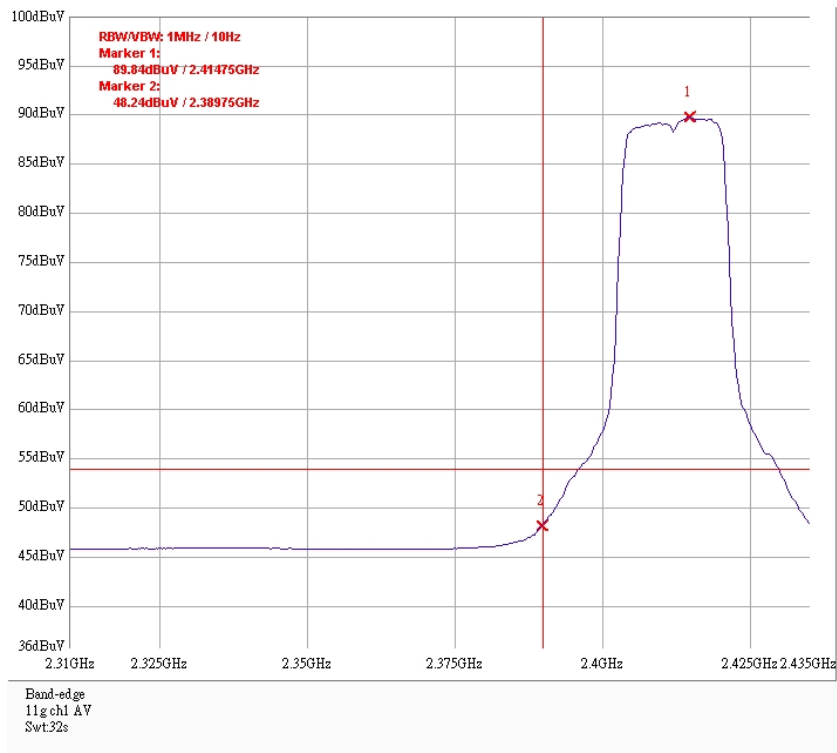

Band edge @ 802.11g mode channel 11 (PK)

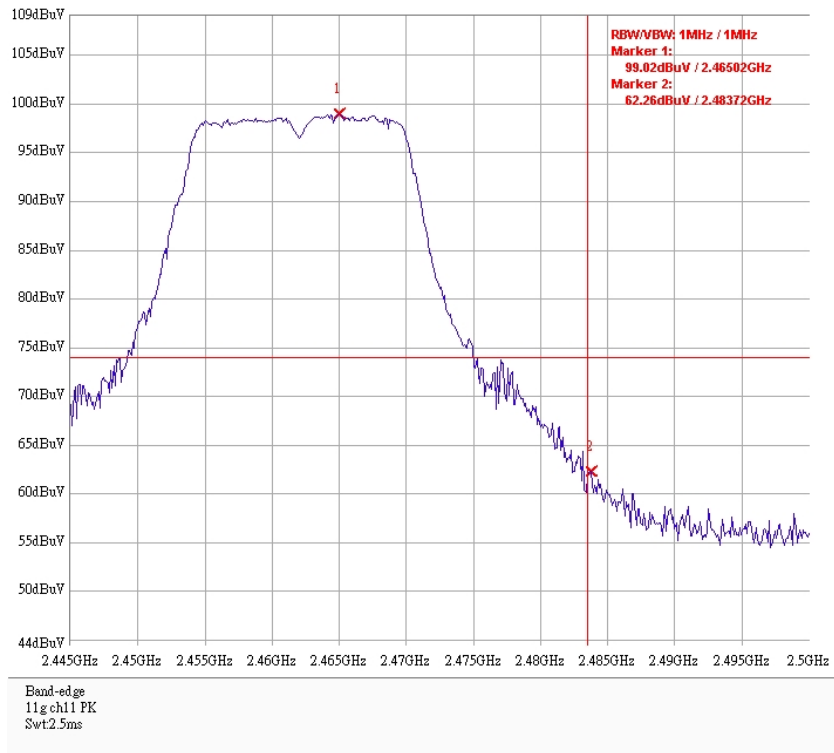

Band edge @ 802.11g mode channel 11 (AV)

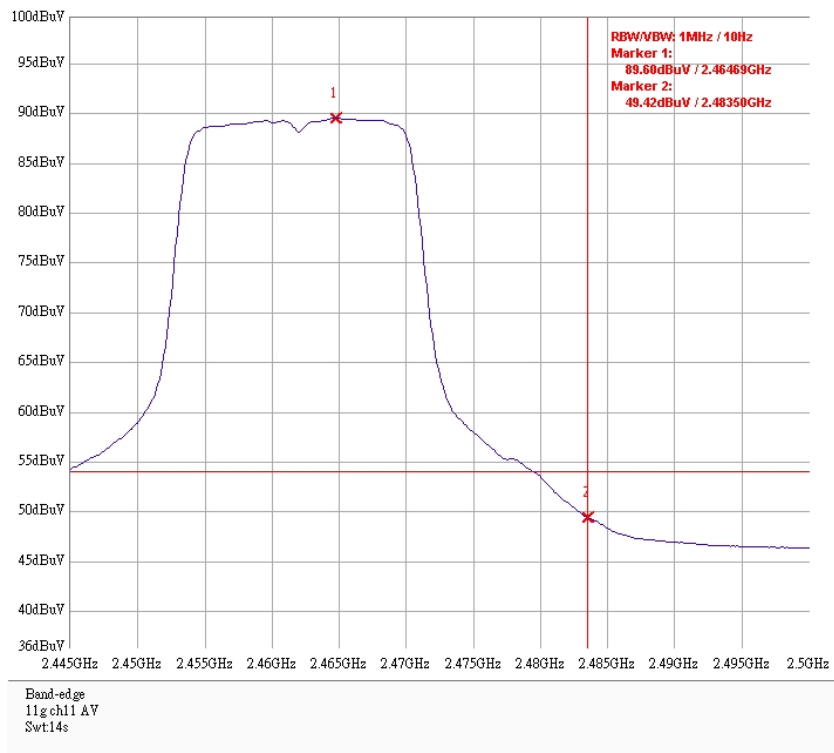

Band edge @ 802.11n HT20 mode channel 1 (PK)

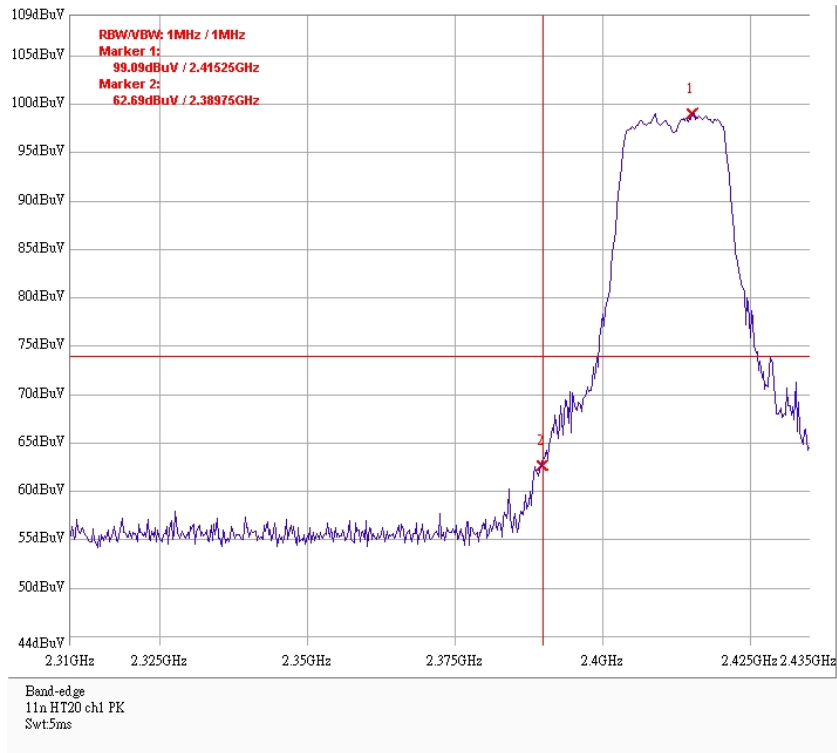

Band edge @ 802.11n HT20 mode channel 1 (AV)

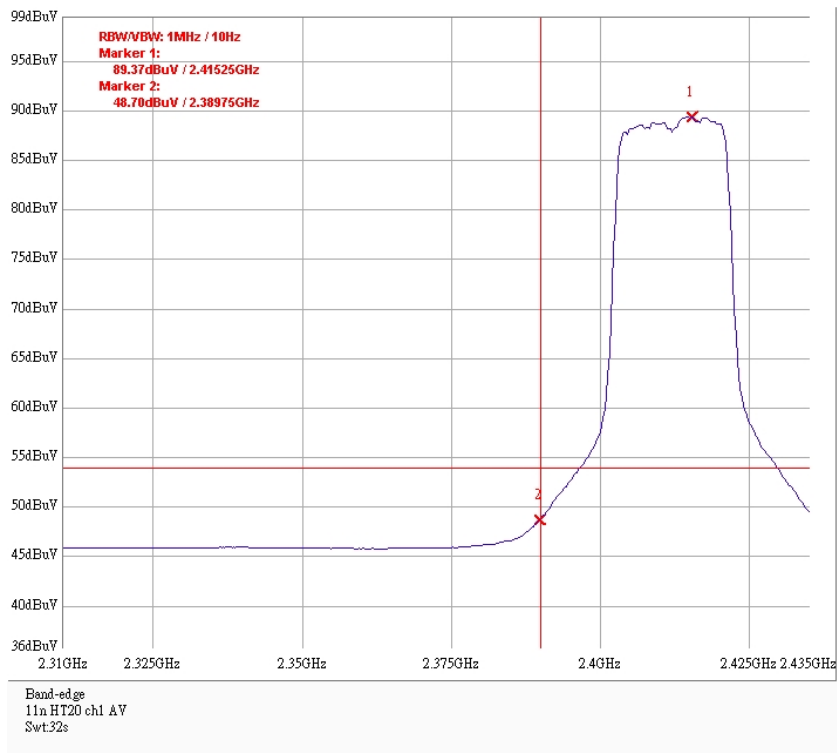

Band edge @ 802.11n HT20 mode channel 11 (PK)

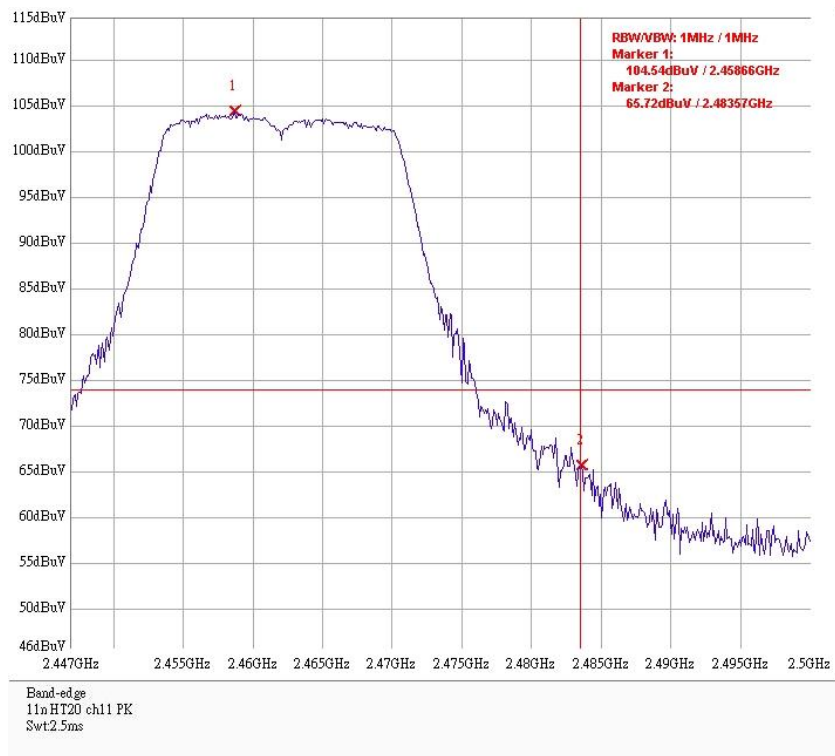

Band edge @ 802.11n HT20 mode channel 11 (AV)

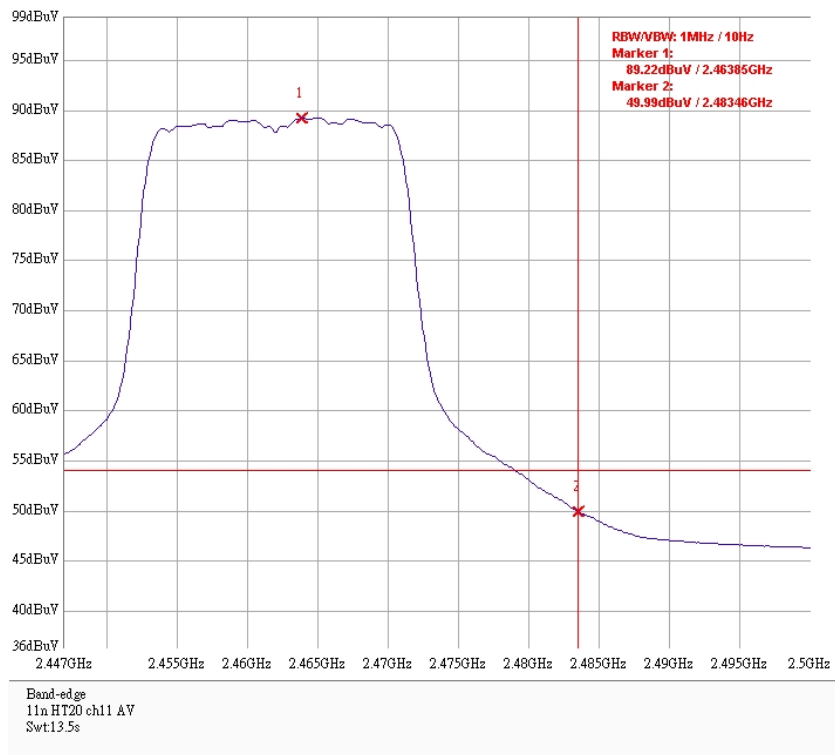

Band edge @ 802.11n HT40 mode channel 3 (PK)

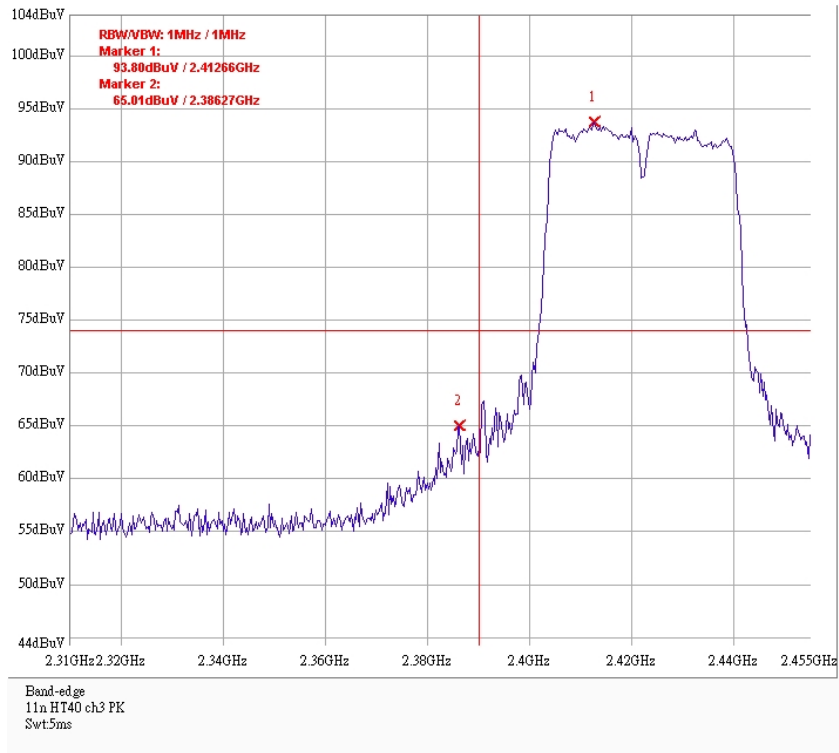

Band edge @ 802.11n HT40 mode channel 3 (AV)

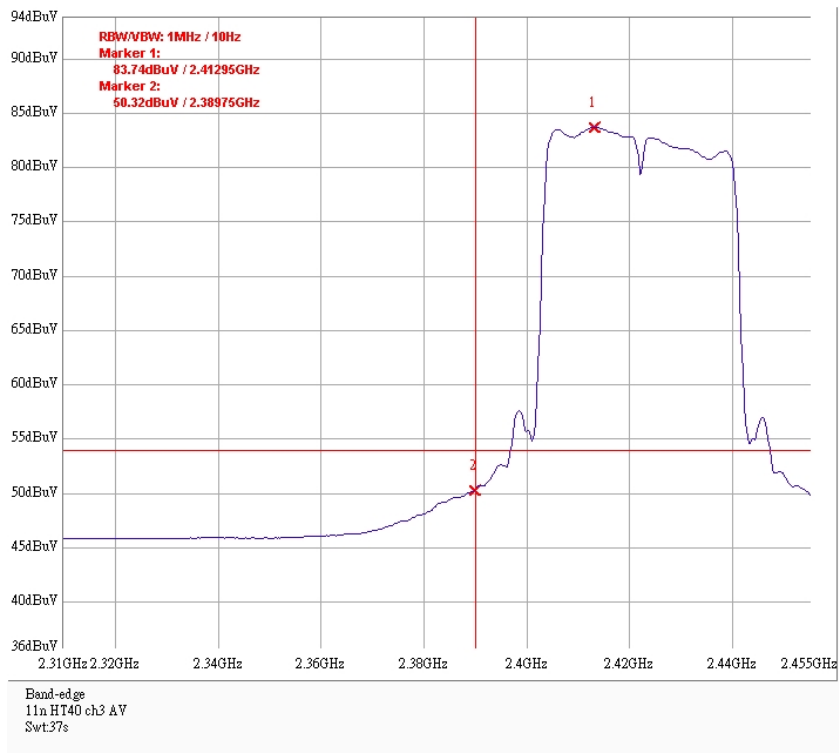

Band edge @ 802.11n HT40 mode channel 9 (PK)

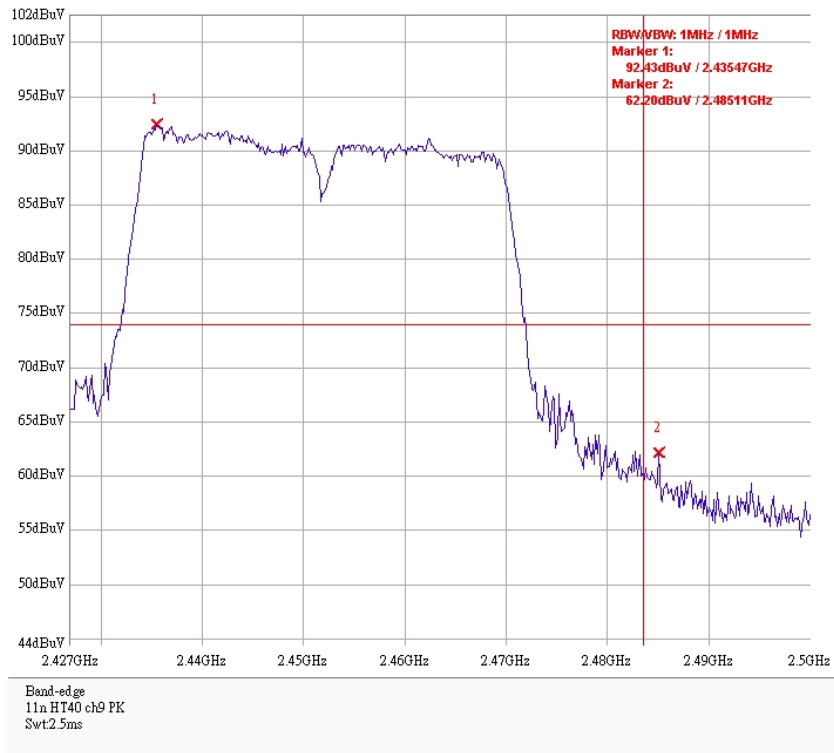

Band edge @ 802.11n HT40 mode channel 9 (AV)

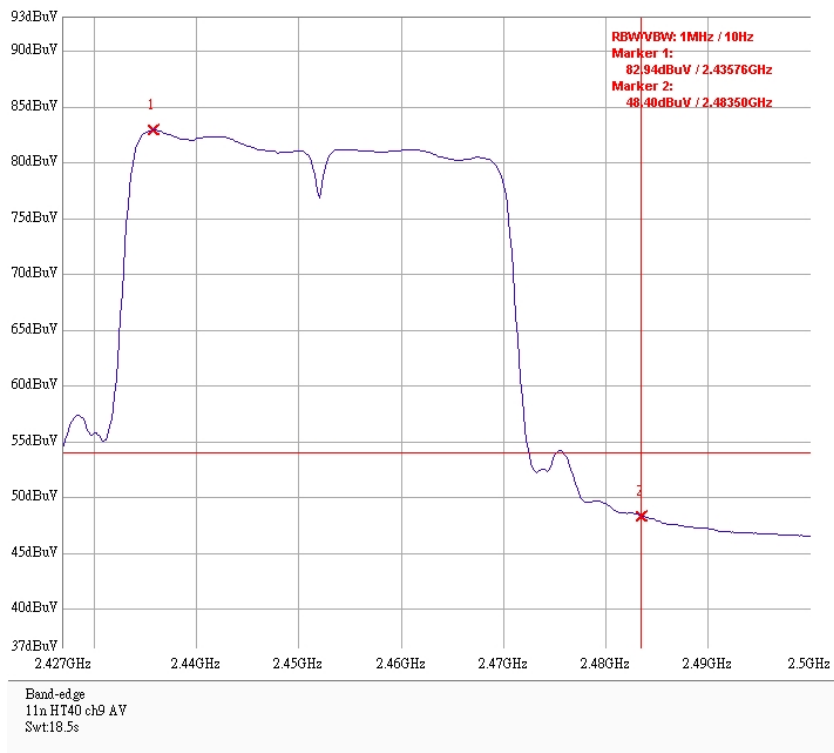

10. AC power line conducted emission

Name of Test	AC power line conducted emission
Base Standard	FCC 15.207

Test Result: Complies
Measurement Data: See Tables & plots below

Method of Measurement:

Reference FCC document: KDB558074, ANSI C63.4

The EUT are connected to the main power through a line impedance stabilization network (LISN). This provides a 50 ohm/50 uH coupling impedance for the measuring equipment. The peripheral devices are also connected to the main power through a LISN that provides a 50 ohm/ 50 uH coupling impedance with 50 ohm termination.

Both sides (Line and Neutral) of AC line are checked for maximum conducted interference. In order to find the maximum emission, the relative positions of equipment and all of the interface cables must be changed according to ANSI C63.4/2003 on conducted measurement.

The bandwidth of the field strength meter (R & S Test Receiver ESCS 30) is set at 9kHz.

The EUT configuration please refers to the “Conducted set-up photo.pdf”.

Test Diagram:

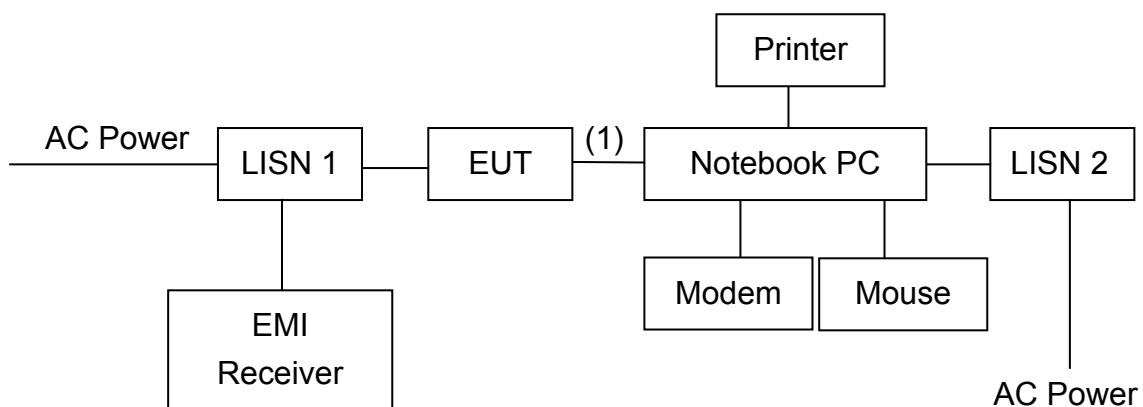

(1) USB shielded cable 0.1 meter × 1

Emission Limit:

Freq. (MHz)	Conducted Limit (dBuV)	
	Q.P.	Ave.
0.15~0.50	66 – 56*	56 – 46*
0.50~5.00	56	46
5.00~30.0	60	50

*Decreases with the logarithm of the frequency.

Note: The EUT was tested while in normal communication mode.

Phase : Line
EUT : WiFiHU-c-2-NE

Frequency (MHz)	Corr. Factor (dB)	Level Qp (dBuV)	Limit Qp (dBuV)	Level Av (dBuV)	Limit Av (dBuV)	Margin (dB)	
						Qp	Av
0.170	0.80	50.42	64.97	47.43	54.97	-14.55	-7.54
0.227	0.67	44.61	62.57	38.80	52.57	-17.96	-13.77
0.283	0.45	37.75	60.72	39.58	50.72	-22.97	-17.14
1.762	0.12	30.98	56.00	22.83	46.00	-25.02	-23.17
1.928	0.10	31.63	56.00	21.65	46.00	-24.37	-24.35
3.346	0.23	30.94	56.00	16.46	46.00	-25.06	-29.54
3.583	0.25	34.66	56.00	22.39	46.00	-21.34	-23.61

Remark:

1. Correction Factor (dB) = LISN Factor (dB) + Cable Loss (dB)
2. Margin (dB) = Level (dBuV) – Limit (dBuV)

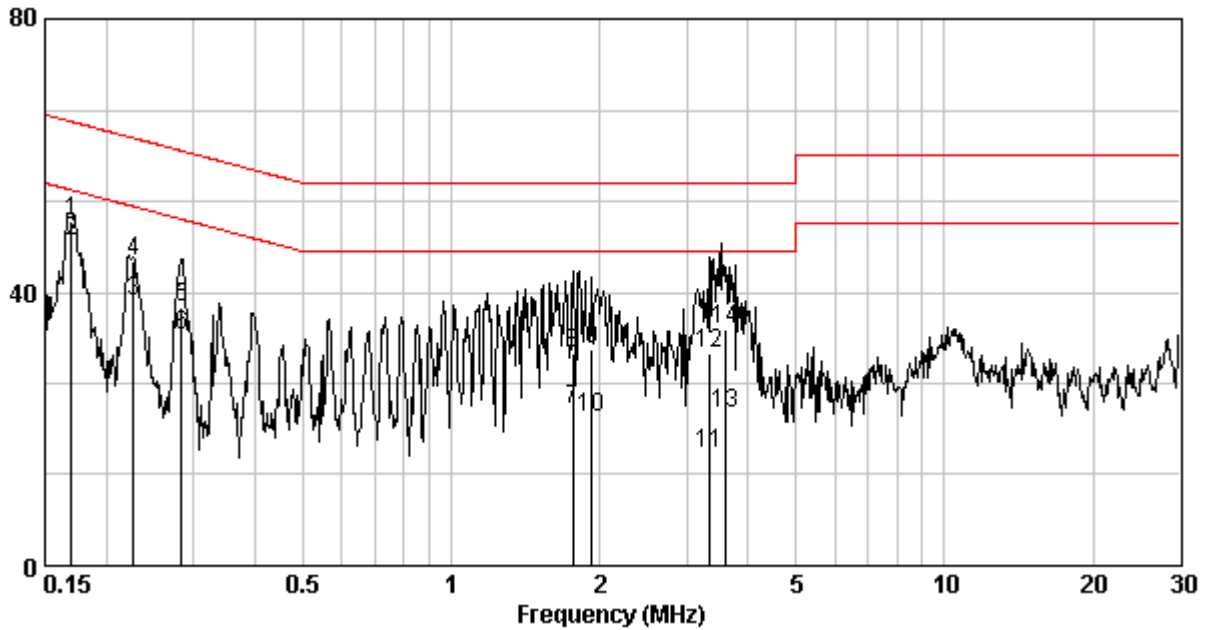

Phase : Neutral
EUT : WiFiHU-c-2-NE

Frequency (MHz)	Corr. Factor (dB)	Level Qp (dBuV)	Limit Qp (dBuV)	Level Av (dBuV)	Limit Av (dBuV)	Margin (dB)	
						Qp	Av
0.169	0.10	49.18	65.03	44.71	55.03	-15.85	-10.32
1.527	0.14	36.61	56.00	27.65	46.00	-19.39	-18.35
1.810	0.11	39.23	56.00	29.85	46.00	-16.77	-16.15
1.920	0.11	40.38	56.00	31.20	46.00	-15.62	-14.80
3.505	0.24	41.58	56.00	27.65	46.00	-14.42	-18.35
3.681	0.25	31.60	56.00	18.77	46.00	-24.40	-27.23
3.901	0.27	36.20	56.00	22.42	46.00	-19.80	-23.58

Remark:

1. Correction Factor (dB)= LISN Factor (dB) + Cable Loss (dB)
2. Margin (dB) = Level (dBuV) – Limit (dBuV)

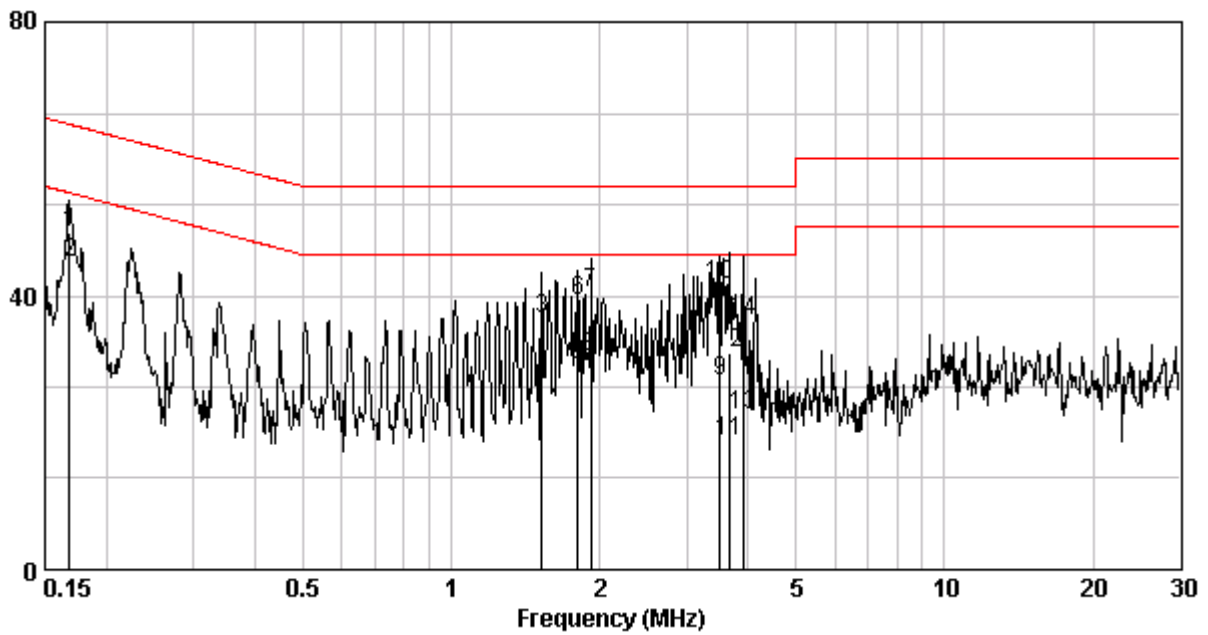

APPENDICES

Appendix A: Test Equipment List

Equipment	Brand	Frequency range	Model No.	Last Cal.	Cal. interval
EMI Test Receiver	Rohde & Schwarz	9kHz~2.75GHz	ESCS 30	2010/9/3	1 year
EMI Test Receiver	Rohde & Schwarz	9kHz~3GHz	ESCI	2010/12/3	1 year
Spectrum Analyzer	Rohde & Schwarz	9kHz~30GHz	FSP 30	2010/8/16	1 year
Spectrum Analyzer	Rohde & Schwarz	20Hz~40GHz	FSEK 30	2011/1/18	1 year
Horn Antenna	SCHWARZBECK	1GHz~18GHz	BBHA9120D	2010/8/31	2 years
Bilog Antenna	SCHWARZBECK	25MHz~1.7GHz	VULB 9168	2009/9/22	2 years
Turn Table	HDGmbH	N/A	DS 420S	N/A	N/A
Antenna Tower	HDGmbH	N/A	MA 240	N/A	N/A
Pre-Amplifier	MITER	100MHz~26.5GHz	AFS42-00102 650	2009/10/27	2 years
LISN	Rohde & Schwarz	9KHz~30MHz	ESH3-Z5	2009/3/13	2 years
Power Meter	Anritsu	100kHz ~ 65GHz (video bandwidth:65MHz)	2495A	2010/10/20	1 year
Power Sensor	Anritsu	300MHz ~ 40GHz (video bandwidth:50MHz)	2411B	2010/10/20	1 year

Note: The above equipments are within the valid calibration period.

Measurement Uncertainty:

Measurement uncertainty was calculated in accordance with TR 100 028-1.

Parameter	Uncertainty
Radiated Emission	±5.056 dB
Conducted Emission	±2.786 dB

This uncertainty represents an expanded uncertainty expressed at approximately the 95 % confidence level using a coverage factor of k=2.