

Radicom Research, Inc.

Preliminary Designers Guide

for the

BPM2001 BPM2001-EK

RoHS Bluetooth HCI Modules



BPM2001 SMD Module



BPM2001-HM Dip Module

November 22th, 2012

A decorative banner with a ribbon-like shape, containing the text "Table of Contents" in a bold, italicized serif font.

Table of Contents

Introduction	3
Features	4
Applications	5
Specifications	6
Electronic Character	7
Model and Ordering Information	7
Layout Design Considerations	8
BPM2001 SMD Module Mechanical Diagram & Pin Assignments	9
BPM2001 SMD Module Interface Signal Definitions	10
BPM2001-HM Mechanical Diagram & Pin Assignments	12
BPM2001-EK Switches & Connector Functional Descriptions	16
Operating the BPM2001-EK Evaluation Kit	17
BPM2001-MB Carrier Board RS232 DE-9 Pin Definitions	17
FCC & IC Label and Model Identification	18
Important Regulatory Compliance and User Information	19
Industry Canada statement:	21
CE Declaration of Conformity	24
Limited Warranty	25
Contacting Radicom	27

Information furnished by Radicom is believed to be accurate and reliable. However Radicom assumes no responsibility for its use, or any infringement of patents or other rights of third parties that may result from its use. Radicom reserves the right to change circuitry at any time without notice. This document is subject to change without notice.

Introduction

Radicom BPM2001 is a single chip based radio and baseband for Bluetooth v4.0 systems and Bluetooth low energy. With host software, BPM2001 provides a system fully qualified to the Bluetooth v4.0 specification for data and voice applications.

Features

- Fully qualified Bluetooth Bluetooth® v4.0 system
- Full-speed Bluetooth operation with full piconet and scatternet support
- Class 2 Bluetooth power level supported
- High-sensitivity Bluetooth receiver
- Wideband speech
- SBC encoding
- Low-power selectable 1.2 to 3.6V I/O
- Full-speed USB 2.0 interface
- High-speed UART port (up to 4Mbps)
- 2 x PCM/I2S digital audio interfaces
- Support for IEEE 802®.11 coexistence
- Dual-mode Bluetooth low energy radio
- 3 Bluetooth low energy connections at the same time as basic rate A2DP
- Approx. 27.9mm x 16.5mm FR4 PCB.
- On-board antenna
- -40°C to +85°C temperature operating
- RoHS compliant

Applications

- Industrial
- Medical
- For AP Switch, Router, PC, NB, PND, PDA, Mobile devices, USB dongle





Specifications

Dimensions	27.94mm x 16.51mm x 2.20mm (BPM2001) 83.73mm x 66.11mm (BPM2001HM)
Device Type	Embedded Bluetooth OEM modules
Interface	Serial UART / PCM / I2S / USB
Data Link Protocol	Bluetooth 4.0
Frequency	2.402 – 2.480 GHz
Transmit Power	6 dBm (typical)
Receiver Sensitivity	-92.5dBm (typical)
Bluetooth Class	Class 2
Range	Up to 10 meters
Security	128-bit encryption (optional)
Power Consumption	IDE: 3~6mA / Play: 22~38mA
Power Supply Voltage	1.8V~ 3.6V
Normal Voltage	3.3V
Operating Temperature	-40°C to +85°C
Environmental	RoHS compliant

Electronic Character

	Minimum	Typical	Maximum	Unit
Operation voltage	1.8	3.3	3.6	V
Output Power		6		dBm
Sensitivity		-84		dBm
active mode, VBAT=3.3V		24		mA

Model and Ordering Information

Model Number	Description
<p>BPM2001</p> 	<p>Surface mount, class 2, Bluetooth HCI module with on-board antenna</p>
<p>BPM2001-HM</p> 	<p>BPM2001HM-a: DIP, through hole module with on-board antenna. BPM2001HM-c: DIP, through hole module with U.FL antenna connector for external antenna</p>
<p>BPM2001-MB</p> 	<p>BPM2001-MB Evaluation PCB Model: BPM2001-MB</p>
<p>BPM2001-EK</p> 	<p>Evaluation Kit. Each kit consists of the following components:</p> <ol style="list-style-type: none"> 1. BPM2001HM (-a or -c) on a testing board 2. USB cables (A to B) 3. Null modem cables (DB9F to DB9F) <p>* BPM2001HM-c ships with 1 external antenna and cable.</p>

Layout Design Suggestions

• **General Layout Rules-** All Printed Circuit Boards must comply with UL94V0 standard for flammability. Always use RoHS compliant Parts and materials.

• **Suggestions for Layout:**

1. Do not place Power circuit, X'tal, Inductor, etc near RF area.
2. The bigger Antenna clearance area, the better. The Antenna itself needs to stay away from any circuit or component at least 2mm. Antenna clearance area means Top and Bottom both required to be cleared.
3. Do not use metal materials on design where near Antenna area. For example, battery snaps, USB connector, iron case, etc.
4. Except ground, do not place any circuit below Bluetooth IC. The area below Bluetooth IC is required to be ground and be connected by through hole.
5. When meeting a turning point, try to make the circuit as smooth as you can.
6. Put all TP (Test-Point) in one area, in order to make easier for a fixture design.
7. Within the acceptance, please make circuit diameter as big as you can.
8. If a position hole is needed, please make them in diagonal location. This design could make easier for fixture allocation and save cost in fixture designing.

These guidelines are for design reference; real performance still depends on actual design.

BPM2001 SMD Module Mechanical Diagram & Pin Assignments

Top side view:

- ✧ Board size = 27.940 mm x 16.510 mm
- ✧ Pitch of short and long side = 1.905 mm
- ✧ Pad width = 1.524 mm x 1.000 mm

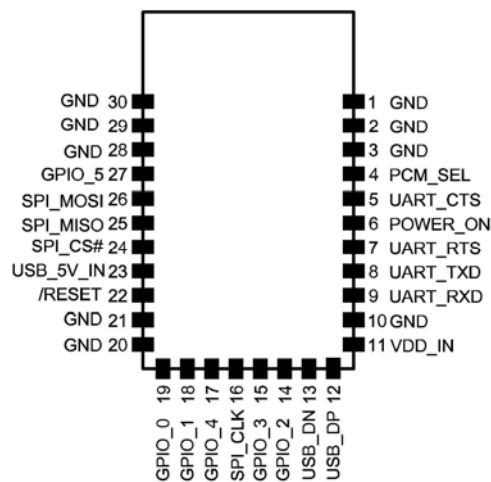
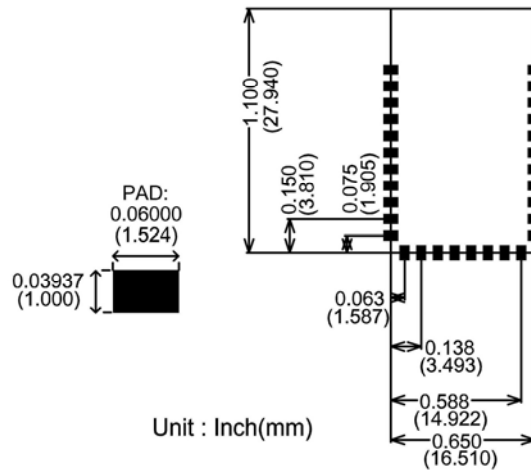

Module Height

- ✧ Maximum height = 2.2 mm
- ✧ Board thickness = 0.80 mm

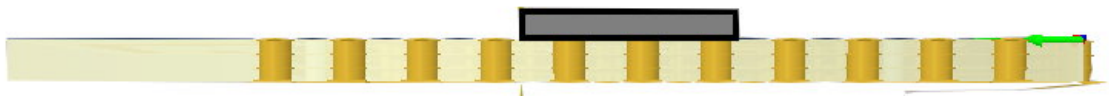

BPM2001 SMD Module Interface Signal Definitions

Pin#	Pin Name	Type	Description	I/O Voltage Range
01	GND	Power	System ground	---
02	GND	Power	System ground	---
03	GND	Power	System ground	---
04	/PCM_SEL	I	High switches SPI/PCM lines to SPI, low switches SPI/PCM lines to PCM/PIO use.	Vih: 0.7 X VDD – VDD + 0.4V Vil: -0.4V -- 0.4 VDD
05	UART_CTS	I	UART clear to send, active low	Vih: 0.7 X VDD – VDD + 0.4V Vil: -0.4V -- 0.4 VDD
06	POWER_ON	I	Take high to enable internal regulators. Maximum voltage is VREG_IN_HV. Note: USB regulator is always enabled and not controlled by VREG_EN	Vih: 0.7 X VDD – VDD + 0.4V Vil: -0.4V -- 0.4 VDD
07	UART_RTS	O	UART request to send, active low	Voh: 0.75 X VDD Vol: 0 – 0.4V
08	UART_TXD	O	UART data output, active high	Voh: 0.75 X VDD Vol: 0 – 0.4V
09	UART_RXD	I	UART data input, active high	Vih: 0.7 X VDD – VDD + 0.4V Vil: -0.4V -- 0.4 VDD
10	GND	Power	System ground	---
11	VDD_IN	Power	1.8V power output	Input voltage: 2.3V – 4.8V
12	USB_DP	I	USB data plus with selectable internal 1.5kΩ pull-up resistor	---
13	USB_DN	I	USB data minus	---
14	GPIO2	I/O	Programmable input/output line	Voh: 0.75 X VDD Vol: 0 – 0.4V Vih: 0.7 X VDD – VDD + 0.4V Vil: -0.4V -- 0.4 VDD
15	GPIO3	I/O	Programmable input/output line	Voh: 0.75 X VDD Vol: 0 – 0.4V Vih: 0.7 X VDD – VDD + 0.4V Vil: -0.4V -- 0.4 VDD
16	SPI_CLK/PCM1CLK	I	SPI clock/ PCM1 port synchronous data clock	Vih: 0.7 X VDD – VDD + 0.4V Vil: -0.4V -- 0.4 VDD
17	GPIO4	I/O	Programmable input/output line	Voh: 0.75 X VDD Vol: 0 – 0.4V Vih: 0.7 X VDD – VDD + 0.4V Vil: -0.4V -- 0.4 VDD

Pin#	Pin Name	Type	Description	I/O Voltage Range
18	GPIO1	I/O	Programmable input/output line	Voh: 0.75 X VDD Vol: 0 – 0.4V Vih: 0.7 X VDD – VDD + 0.4V Vil: -0.4V -- 0.4 VDD
19	GPIO0	I/O	Programmable input/output line	Voh: 0.75 X VDD Vol: 0 – 0.4V Vih: 0.7 X VDD – VDD + 0.4V Vil: -0.4V -- 0.4 VDD
20	GND	Power	System ground	---
21	GND	Power	System ground	---
22	/RESET	I	Active low system reset	Vih: 0.7 X VDD – VDD + 0.4V Vil: -0.4V -- 0.4 VDD
23	USB_5V_IN	I	Input to USB regulator. Connect to external USB bus supply, e.g. USB_VBUS.	Input voltage: 4.20V – 5.75V
24	SPI_CS#/PCM1_SY NC	O	High switches SPI/PCM lines to SPI, low switches SPI/PCM lines to PCM/PIO use.	Voh: 0.75 X VDD Vol: 0 – 0.4V
25	SPI_MISO/PCM1_O UT	O	SPI data output/PCM1 port synchronous data output	Voh: 0.75 X VDD Vol: 0 – 0.4V
26	SPI_MOSI/PCM1_IN	I	SPI data input/PCM1 port synchronous data input	Vih: 0.7 X VDD – VDD + 0.4V Vil: -0.4V -- 0.4 VDD
27	GPIO_5	I/O	I/O port power input	Voh: 0.75 X VDD Vol: 0 – 0.4V Vih: 0.7 X VDD – VDD + 0.4V Vil: -0.4V -- 0.4 VDD
28	GND	Power	System ground	---
29	GND	Power	System ground	---
30	GND	Power	System ground	---

BPM2001-HM Mechanical Drawing & Pin Assignments

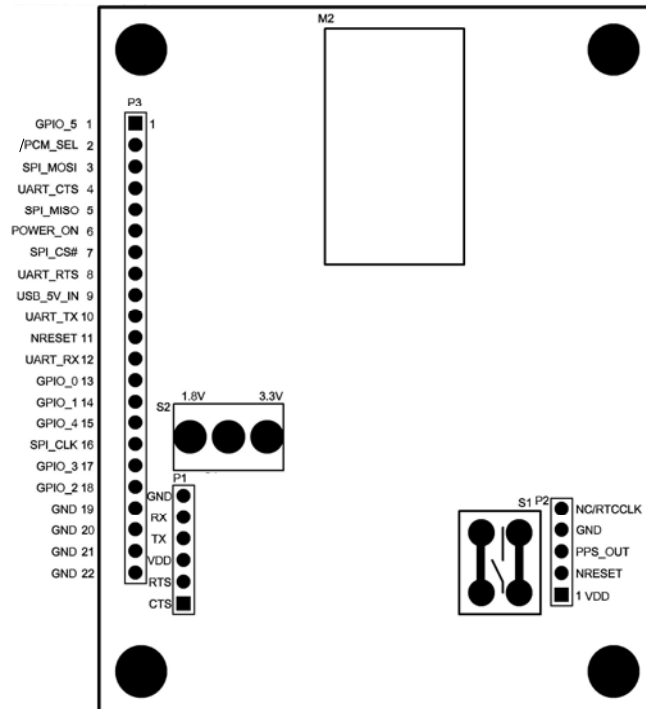
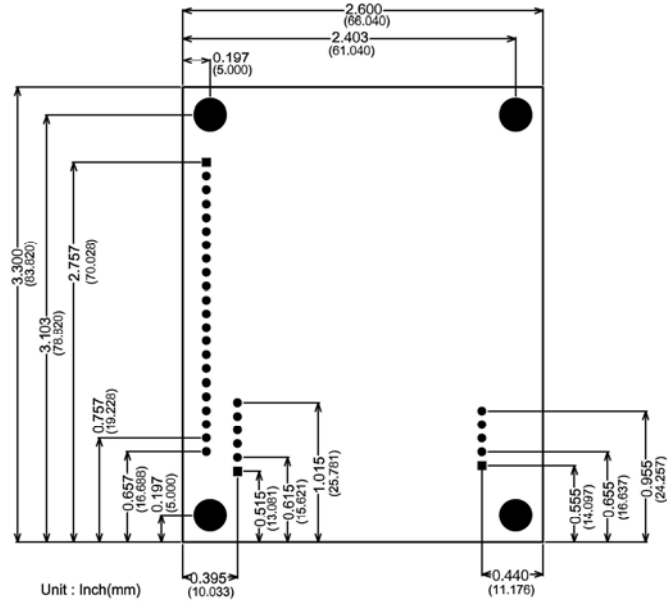

BPM2001-HM Interface Signal Definitions

P3 Port Pin Assignments

Pin#	Pin Name	Type	Description	Voltage Range
1	GPIO_5	I/O	I/O port power input	Voh: 0.75 X VDD Vol: 0 – 0.4V Vih: 0.7 X VDD – VDD + 0.4V Vil: -0.4V -- 0.4 VDD
2	/PCM_SEL	I	High switches SPI/PCM lines to SPI, low switches SPI/PCM lines to PCM/PIO use.	Vih: 0.7 X VDD – VDD + 0.4V Vil: -0.4V -- 0.4 VDD
3	SPI_MOSI	I	SPI data input/PCM1 port synchronous data input	Vih: 0.7 X VDD – VDD + 0.4V Vil: -0.4V -- 0.4 VDD
4	UART_CTS	I	UART clear to send, active low	Vih: 0.7 X VDD – VDD + 0.4V Vil: -0.4V -- 0.4 VDD
5	SPI_MISO/PCM1_OUT	O	SPI data output/PCM1 port synchronous data output	Voh: 0.75 X VDD Vol: 0 – 0.4V
6	POWER_ON	I	Take high to enable internal regulators. Maximum voltage is VREG_IN_HV. Note:	Vih: 0.7 X VDD – VDD + 0.4V Vil: -0.4V -- 0.4 VDD
7	SPI_CS#	O	High switches SPI/PCM lines to SPI, low switches SPI/PCM lines to PCM/PIO use.	Voh: 0.75 X VDD Vol: 0 – 0.4V
8	UART_RTS	O	UART request to send, active low	Voh: 0.75 X VDD Vol: 0 – 0.4V
9	USB_5V_IN	I	Input to USB regulator. Connect to external USB	Input voltage: 4.20V – 5.75V
10	UART_TXD	O	UART data output, active high	Voh: 0.75 X VDD Vol: 0 – 0.4V
11	/RESET	I	Active low system reset	Vih: 0.7 X VDD – VDD + 0.4V Vil: -0.4V -- 0.4 VDD
12	UART_RXD	I	UART data input, active high	Vih: 0.7 X VDD – VDD + 0.4V Vil: -0.4V -- 0.4 VDD
13	GPIO0	I/O	Programmable input/output line	Voh: 0.75 X VDD Vol: 0 – 0.4V Vih: 0.7 X VDD – VDD + 0.4V Vil: -0.4V -- 0.4 VDD
14	GPIO1	I/O	Programmable input/output line	Voh: 0.75 X VDD Vol: 0 – 0.4V Vih: 0.7 X VDD – VDD + 0.4V Vil: -0.4V -- 0.4 VDD
15	GPIO4	I/O	Programmable input/output line	Voh: 0.75 X VDD Vol: 0 – 0.4V Vih: 0.7 X VDD – VDD + 0.4V Vil: -0.4V -- 0.4 VDD
16	SPI_CLK/PCM1CLK	I	SPI clock/ PCM1 port synchronous data clock	Vih: 0.7 X VDD – VDD + 0.4V Vil: -0.4V -- 0.4 VDD
17	GPIO2	I/O	Programmable input/output line	Voh: 0.75 X VDD Vol: 0 – 0.4V Vih: 0.7 X VDD – VDD + 0.4V Vil: -0.4V -- 0.4 VDD
18	GPIO3	I/O	Programmable input/output line	Voh: 0.75 X VDD Vol: 0 – 0.4V Vih: 0.7 X VDD – VDD + 0.4V Vil: -0.4V -- 0.4 VDD

Pin#	Pin Name	Type	Description	Voltage Range
19	GND	Power	System ground	---
20	GND	Power	System ground	---
21	GND	Power	System ground	---
22	GND	Power	System ground	---

P1 Port Pin Assignments

Pin#	Pin Name	Type	Description	Voltage Range
1	UART_CTS	I	UART clear to send, active low	Vih: $0.7 \times VDD - VDD + 0.4V$ Vil: $-0.4V - -0.4 VDD$
2	UART_RTS	O	UART request to send, active low	Voh: $0.75 \times VDD$ Vol: $0 - 0.4V$
3	VDD	I	HM Power In	Input voltage: $4.30V - 5.75V$
4	UART_TXD	O	UART data output, active high	Voh: $0.75 \times VDD$ Vol: $0 - 0.4V$
4	UART_RXD	I	UART data input, active high	Vih: $0.7 \times VDD - VDD + 0.4V$ Vil: $-0.4V - -0.4 VDD$
6	GND	Power	System ground	---

Operating the BPM2001-EK Evaluation Kit

The BPM2001-MB Evaluation PCB has white silkscreen legend located by the switches and connectors described below.

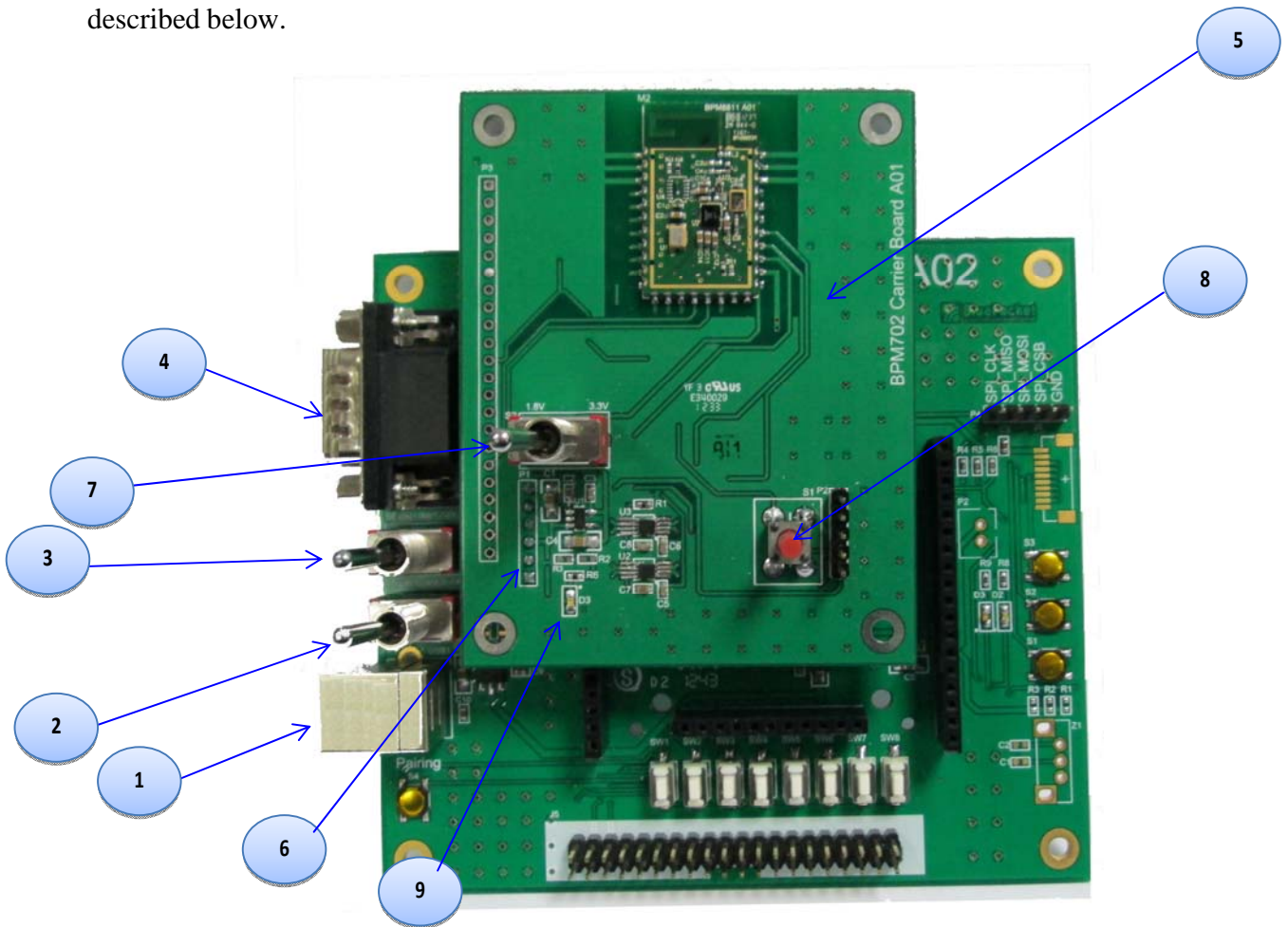

1. USB 5V slot (USB1)
2. Main board power switch (S5)
3. UART enable/disable switch (S6)
4. RS232 male DE-9 connector (J7)
5. BPM2001-HM carrier board with module
6. UART and power interface header (P1)
7. HM board power switch only for 1.8V (S2)
8. Reset push button (S1)
9. HM Power indicator (D3)

Operating the BPM2001-EK Evaluation Kit

-On PC (Master):

1. Connect UART cable to PC com port and supply power
2. Execute "cmd" under Windows
3. cd "c:\Program Files\CSR\BlueSuite 2.4.8"
4. btcli com1 bcsp 115200
5. Verify "command_status pending nhcp:0x01 nop"
6. Type "rbn" and verify displayed strings (8 lines)
7. Type exec "d:\d-drive\gps\csr8311\8311.btcli"
8. Wait for "*** HCI TRANSPORT FAILED ***"
9. Type "restart"
10. Verify "command_status pending nhcp:0x01 nop"
11. Type "i" to start inquiry
12. Type "cc 0X00000001" ←(BD Address)
13. Type "acl acl0 "ABCD" "

-On PC (Slave):

1. Connect UART cable to PC com port and supply power
2. Execute "cmd" under Windows
3. cd "c:\Program Files\CSR\BlueSuite 2.4.8"
4. btcli com1 bcsp 115200
5. Verify "command_status pending nhcp:0x01 nop"
6. Type "rbn" and verify displayed strings (8 lines)
7. Type exec "d:\d-drive\gps\csr8311\8311.btcli"
8. Wait for "*** HCI TRANSPORT FAILED ***"
9. Type "restart"
10. Verify "command_status pending nhcp:0x01 nop"
11. Type " slave " to slave mode

BPM2001-MB Carrier Board RS232 DE-9 Pin Definitions

UART interface is used for firmware download and debug purpose. The DE-9 pin definitions of the BPM2001-MB RS232 Serial Connector are as follows:

1. DCD: Input, Carrier Detect
2. RXD: Input, Received Data
3. TXD: Output, Transmit data
4. DTR: Output, Data Terminal ready
5. GND: Ground
6. DSR: Input, Data Set Ready
7. RTS: Output, Request to Send
8. CTS: Input, Clear to Send
9. RI: Input, Ring Indicator

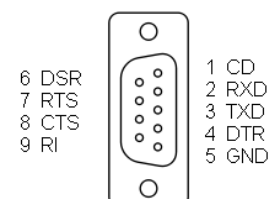

FCC & IC Label and Model Identification

The BPM2001 module family is FCC Part 15 and IC (Industry Canada) certified. The BPM2001 is also CE marked. The modules are labeled with the BPM2001 module model number and FCC Part 15 ID, IC registration number and CE mark. The label can be found on top of the metal shielding on the BPM2001 Module.

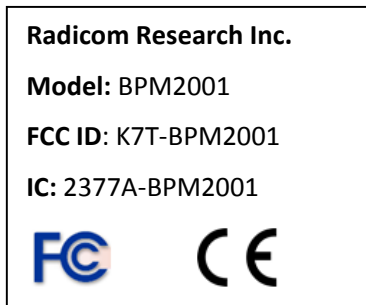

Location:

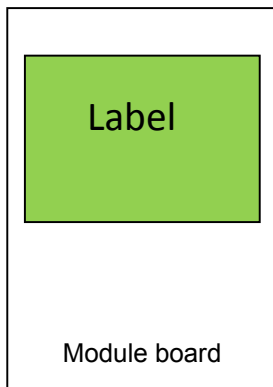

Federal Communication Commission Interference Statement

This equipment has been tested and found to comply with the limits for a Class B digital device, pursuant to Part 15 of the FCC Rules. These limits are designed to provide reasonable protection against harmful interference in a residential installation. This equipment generates, uses and can radiate radio frequency energy and, if not installed and used in accordance with the instructions, may cause harmful interference to radio communications. However, there is no guarantee that interference will not occur in a particular installation. If this equipment does cause harmful interference to radio or television reception, which can be determined by turning the equipment off and on, the user is encouraged to try to correct the interference by one of the following measures:

- Reorient or relocate the receiving antenna.
- Increase the separation between the equipment and receiver.
- Connect the equipment into an outlet on a circuit different from that to which the receiver is connected.
- Consult the dealer or an experienced radio/TV technician for help.

FCC Caution: Any changes or modifications not expressly approved by the party responsible for compliance could void the user's authority to operate this equipment.

This device complies with Part 15 of the FCC Rules. Operation is subject to the following two conditions: (1) This device may not cause harmful interference, and (2) this device must accept any interference received, including interference that may cause undesired operation.

IMPORTANT NOTE:**FCC Radiation Exposure Statement:**

The product comply with the US portable RF exposure limit set forth for an uncontrolled environment and are safe for intended operation as described in this manual. The further RF exposure reduction can be achieved if the product can be kept as far as possible from the user body or set the device to lower output power if such function is available.

This transmitter must not be co-located or operating in conjunction with any other antenna or transmitter.

This device is intended only for OEM integrators under the following conditions:

- 1) The transmitter module may not be co-located with any other transmitter or antenna,

As long as 1 condition above is met, further transmitter test will not be required. However, the OEM integrator is still responsible for testing their end-product for any additional compliance requirements required with this module installed

IMPORTANT NOTE

In the event that these conditions can not be met (for example certain laptop configurations or co-location with another transmitter), then the FCC authorization is no longer considered valid and the FCC ID can not be used on the final product. In these circumstances, the OEM integrator will be responsible for re-evaluating the end product (including the transmitter) and obtaining a separate FCC authorization.

End Product Labeling

The final end product must be labeled in a visible area with the following: “Contains FCC ID: **K7T-BPM2001**”.

Manual Information to the End User

The OEM integrator has to be aware not to provide information to the end user regarding how to install or remove this RF module in the user’s manual of the end product which integrates this module.

The end user manual shall include all required regulatory information/warning as show in this manual.

Industry Canada statement:

This device complies with Industry Canada licence-exempt RSS standard(s). Operation is subject to the following two conditions:

(1) this device may not cause interference, and

(2) this device must accept any interference, including interference that may cause undesired operation of the device.

Le présent appareil est conforme aux CNR d'Industrie Canada applicables aux appareils radio exempts de licence. L'exploitation est autorisée aux deux conditions suivantes :

(1) l'appareil ne doit pas produire de brouillage, et

(2) l'utilisateur de l'appareil doit accepter tout brouillage radioélectrique subi, même si le brouillage est susceptible d'en compromettre le fonctionnement.

Radiation Exposure Statement:

The product comply with the Canada portable RF exposure limit set forth for an uncontrolled environment and are safe for intended operation as described in this manual. The further RF exposure reduction can be achieved if the product can be kept as far as possible from the user body or set the device to lower output power if such function is available.

Déclaration d'exposition aux radiations:

Le produit est conforme aux limites d'exposition pour les appareils portables RF pour les États-Unis et le Canada établies pour un environnement non contrôlé. Le produit est sûr pour un fonctionnement tel que décrit dans ce manuel. La réduction aux expositions RF peut être augmentée si l'appareil peut être conservé aussi loin que possible du corps de l'utilisateur ou que le dispositif est réglé sur la puissance de sortie la plus faible si une telle fonction est disponible.

This device is intended only for OEM integrators under the following conditions:

- 1) The transmitter module may not be co-located with any other transmitter or antenna.

As long as 1 condition above are met, further transmitter test will not be required. However, the OEM integrator is still responsible for testing their end-product for any additional compliance requirements required with this module installed.

Cet appareil est conçu uniquement pour les intégrateurs OEM dans les conditions suivantes:

- 1) Le module émetteur peut ne pas être coïmplanté avec un autre émetteur ou antenne.

Tant que les 1 condition ci-dessus sont remplies, des essais supplémentaires sur l'émetteur ne seront pas nécessaires. Toutefois, l'intégrateur OEM est toujours responsable des essais sur son produit final pour toutes exigences de conformité supplémentaires requis pour ce module installé.

IMPORTANT NOTE:

In the event that these conditions can not be met (for example certain laptop configurations or co-location with another transmitter), then the Canada authorization is no longer considered valid and the IC ID can not be used on the final product. In these circumstances, the OEM integrator will be responsible for re-evaluating the end product (including the transmitter) and obtaining a separate Canada authorization.

NOTE IMPORTANTE:

Dans le cas où ces conditions ne peuvent être satisfaites (par exemple pour certaines configurations d'ordinateur portable ou de certaines co-localisation avec un autre émetteur), l'autorisation du Canada n'est plus considéré comme valide et l'ID IC ne peut pas être utilisé sur le produit final. Dans ces circonstances, l'intégrateur OEM sera chargé de réévaluer le produit final (y compris l'émetteur) et l'obtention d'une autorisation distincte au Canada.

End Product Labeling

The final end product must be labeled in a visible area with the following: "Contains IC:**2377A-BPM2001**".

Plaque signalétique du produit final

Le produit final doit être étiqueté dans un endroit visible avec l'inscription suivante: "Contient des IC: **2377A-BPM2001**".

Manual Information to the End User

The OEM integrator has to be aware not to provide information to the end user regarding how to install or remove this RF module in the user's manual of the end product which integrates this module.

The end user manual shall include all required regulatory information/warning as show in this manual.

Manuel d'information à l'utilisateur final

L'intégrateur OEM doit être conscient de ne pas fournir des informations à l'utilisateur final quant à la façon d'installer ou de supprimer ce module RF dans le manuel de l'utilisateur du produit final qui intègre ce module.

Le manuel de l'utilisateur final doit inclure toutes les informations réglementaires requises et avertissements comme indiqué dans ce manuel.

CE Declaration of Conformity

For the following equipment:

Radicom Research Inc. Bluetooth Module

Model(s): BPM2001

are herewith confirmed to comply with the requirements set out in the Council (European parliament) Directive on the Approximation of the Laws of the Member States relating to Electromagnetic Compatibility of Radio and Telecom device (1999/5/CE).

For the evaluation regarding this Directive, the following standards were applied:

EN 300 328 V1.8.1

EN 301 489-1 V1.9.2

EN 301 489-17 V2.2.1

EN 60950-1 2006+A11:2009+A1:2010+A12:2011

EN 62311: 2008

EN 61000-3-2 : 2006/A2:2009

EN 61000-3-3 : 2008

This equipment is marked with  and can be used throughout the European community.

Europe – R&TTE Compliance Statement:

Hereby, Radicom Research Inc. declares that this equipment complies with the essential requirements

and other relevant provisions of DIRECTIVE 1999/5/CE OF THE EUROPEAN PARLIAMENT AND THE COUNCIL of March 9, 1999 on radio equipment and telecommunication terminal Equipment and the mutual recognition of their conformity (R&TTE).

Limited Warranty

Warranty Coverage and Duration

Radicom Research, Inc. ("RRI") warrants to the original purchaser its RRI-manufactured products ("Product") against defects in material and workmanship under normal use and service for a period of one year from the date of delivery.

During the applicable warranty period, at no charge, RRI will, at its option, either repair, replace or refund the purchase price of this Product, provided it is returned in accordance with the terms of this warranty to RRI. Repair, at the option of RRI, may include the replacement of parts, boards or other components with functionally equivalent reconditioned or new parts, boards or other components. Replaced parts, boards or other components are warranted for the balance of the original applicable warranty period. All replaced items shall become the property of RRI.

RRI MAKES NO GUARANTEE OR WARRANTY THAT THE PRODUCT WILL PREVENT OCCURRENCES, OR THE CONSEQUENCES THEREOF, WHICH THE PRODUCT IS DESIGNED TO DETECT.

This expressed limited warranty is extended by RRI to the original end-user purchaser only, and is not assignable or transferable to any other party. This is the complete warranty for the Product manufactured by RRI, and RRI assumes no obligation or liability for additions or modifications to this warranty. In no case does RRI warrant the installation, maintenance or service of the Product.

RRI is not responsible in any way for any ancillary equipment not furnished by RRI that is attached to or used in connection with the Product, or for operation of the Product with any ancillary equipment, and all such equipment is expressly excluded from this warranty. Because of wide variations in topographical and atmospheric conditions, which may require availability of repeater stations or of particular radio frequencies, RRI assumes no liability for range, coverage or suitability of the Product for any particular application. Buyer acknowledges that RRI does not know a particular purpose for which buyer wants the product, and that buyer is not relying on RRI's skill and judgment to select or furnish suitable goods.

What this Warranty does NOT Cover:

- (a) Defects or damage resulting from use of the Product in other than its normal and customary manner.
- (b) Defects or damage from misuse, accident or neglect.
- (c) Defects of damage from improper testing, operation, maintenance, installation, alteration, modification or adjustment.
- (d) Disassembly or repair of the Product in such a manner as to adversely affect performance or prevent adequate inspection and testing to verify any warranty claim.
- (e) Any Product that has had its serial number or date code removed or made illegible.

How to Receive Warranty Service:

To obtain warranty service, contact RRI by phone (408)383-9006 for your sales representative or email to sales@radi.com for an RMA (Return Merchandise Authorization) number. Deliver or send the Product, transportation and insurance prepaid to RRI, with the RMA number clearly marked on the outside of the package.

General Provision

This warranty sets forth the full extent of RRI's responsibilities regarding the Product. Repair, replacement or refund of the purchase price, at RRI's option, is the exclusive remedy.

THIS WARRANTY IS GIVEN IN LIEU OF ALL OTHER EXPRESSED WARRANTIES. ANY APPLICABLE IMPLIED WARRANTIES, INCLUDING WITHOUT LIMITATION, THE IMPLIED WARRANTY OF MERCHANTABILITY, ARE LIMITED TO THE DURATION OF THIS LIMITED WARRANTY. TO THE FULLEST EXTENT PERMITTED BY LAW, RRI DISCLAIMS ANY LIABILITY FOR DAMAGES IN EXCESS OF THE PURCHASE PRICE OF THE PRODUCT, FOR ANY LOSS OF USE, LOSS OF TIME, INCONVENIENCE, COMMERCIAL LOSS, LOST PROFITS OR SAVING OR OTHER INCIDENTAL, SPECIAL OR CONSEQUENTIAL DAMAGES ARISING OUT OF THE USE OR INABILITY TO USE OR FAILURE OF SUCH PRODUCT.

Contacting Radicom Research

If more information or technical support is needed, please contact us:



2148 Bering Drive

San Jose, CA. 95131

Telephone: (408) 383 9006

Fax: (408) 383 9007

or

e-mail: sales@radi.com

<http://www.radi.com/>