



Test Report No.: FM2405WDG0029



# RF EXPOSURE TEST REPORT



Applicant	Belkin International, Inc.
Address	555 S. Aviation Blvd., Suite 180, El Segundo, CA 90245, USA

Manufacturer or Supplier	Belkin International, Inc.
Address	555 S. Aviation Blvd., Suite 180, El Segundo, CA 90245, USA
Product	BoostCharge Pro Magnetic Car Charger
Brand Name	belkin
Model	WIC008V2
Additional Model & Model Difference	N/A
Date of tests	May 08, 2024 ~ May 22, 2024

The submitted sample of the above equipment has been tested according to the requirements of the following standard:

- 47 CFR PART 1, Subpart I, Section 1.1310
- KDB 680106 D01

**CONCLUSION: The submitted sample was found to COMPLY with the test requirement**

Tested by Eric Fang Project Engineer / EMC Department	Approved by Glyn He Assistant Manager/ EMC Department
	
	Date: May 30, 2024

This report is governed by, and incorporates by reference, the Conditions of Testing as posted at the date of issuance of this report at <http://www.bureauveritas.com/home/about-us/our-business/cps/about-us/terms-conditions/> and is intended for your exclusive use. Any copying or replication of this report to or for any other person or entity, or use of our name or trademark, is permitted only with our prior written permission. This report sets forth our findings solely with respect to the test samples identified herein. The results set forth in this report are not indicative or representative of the quality or characteristics of the lot from which a test sample was taken or any similar or identical product unless specifically and expressly noted. Our report includes all of the tests requested by you and the results thereof based upon the information that you provided to us. Measurement uncertainty is only provided upon request for accredited tests. Statements of conformity are based on simple acceptance criteria without taking measurement uncertainty into account, unless otherwise requested in writing. You have 60 days from date of issuance of this report to notify us of any material error or omission caused by our negligence or if you require measurement uncertainty; provided, however, that such notice shall be in writing and shall specifically address the issue you wish to raise. A failure to raise such issue within the prescribed time shall constitute your unqualified acceptance of the completeness of this report, the tests conducted and the correctness of the report contents.

Bureau Veritas Shenzhen Co.,  
Ltd. Dongguan Branch

No. 96, Guantai Road (Houjie Section), Houjie  
Town, Dongguan City, Guangdong Province.  
523942. People's Republic of China.

Tel.: +86 769 8998 2098  
Fax: +86 769 8593 1080  
Email: [customerservice.dg@bureauveritas.com](mailto:customerservice.dg@bureauveritas.com)



## TABLE OF CONTENTS

RF EXPOSURE TEST REPORT .....	1
RELEASE CONTROL RECORD.....	3
<b>1. GENERAL INFORMATION.....</b>	<b>4</b>
1.1. GENERAL DESCRIPTION OF EUT .....	4
<b>2. RF EXPOSURE MEASUREMENT .....</b>	<b>5</b>
2.1 LIMITS .....	5
2.2 DESCRIPTION OF SUPPORT UNITS.....	5
2.3 CONFIGURATION OF SYSTEM UNDER TEST.....	6
2.4 TEST SETUP FOR WPC .....	7
2.5 EQUIPMENTS USED DURING TEST .....	7
2.6 TEST POINT DESCRIPTION .....	8
2.7 TEST RESULTS.....	9
<b>3. PHOTOGRAPHS OF THE TEST CONFIGURATION.....</b>	<b>12</b>



Test Report No.: FM2405WDG0029

## RELEASE CONTROL RECORD

ISSUE NO.	REASON FOR CHANGE	DATE ISSUED
FM2405WDG0029	Original release	May 30, 2024

## 1. GENERAL INFORMATION

### 1.1. GENERAL DESCRIPTION OF EUT

<b>FCC ID</b>	K7SWIC008V2
<b>PRODUCT</b>	BoostCharge Pro Magnetic Car Charger
<b>MODEL NO.</b>	WIC008V2
<b>ADDITIONAL MODEL</b>	N/A
<b>POWER SUPPLY</b>	DC 9V From Car Charger
<b>MODULATION TECHNOLOGY</b>	FSK
<b>OPERATING FREQUENCY RANGE</b>	127.7kHz & 360KHz
<b>ANTENNA TYPE</b>	Coil Antenna
<b>I/O PORTS</b>	Refer to user's manual
<b>CABLE SUPPLIED</b>	See note 4

#### NOTES:

- For a more detailed features description, please refer to the manufacturer's specifications or the user's manual.
- For the test results, the EUT had been tested with all conditions, but only the worst case was shown in test report.
- Please refer to the EUT photo document (Reference No.: 2405WDG0029) for detailed product photo.
- Product cable information as follows:

ID	Descriptions	Qty.	Length (m)	Shielding (Y/N)	Cores (Qty.)	Remark
1	USB-C Line	1	1.2	Y	0	N/A

- Car charger information as follows:

<b>20Watt Power Adapter</b>	
<b>MODEL NO.:</b>	CCA003V2
<b>BRAND NAME:</b>	Belkin
<b>INPUT:</b>	12-24V/2.5A
<b>OUTPUT:</b>	5.0V/3.0A, 9.0V/2.22A

## 2. RF EXPOSURE MEASUREMENT

### 2.1 LIMITS

§ 1.1310 The criteria listed in table 1 shall be used to evaluate the environmental impact of human exposure to radiofrequency(RF) radiation as specified in § 1.1307(b), except in the case of portable devices which shall be evaluated according to the provisions of § 2.1093 of this chapter.

TABLE 1—LIMITS FOR MAXIMUM PERMISSIBLE EXPOSURE (MPE)

Frequency range (MHz)	Electric field strength (V/m)	Magnetic field strength (A/m)	Power density (mW/cm <sup>2</sup> )	Averaging time (minutes)
<b>(A) Limits for Occupational/Controlled Exposures</b>				
0.3–3.0 .....	614	1.63	*(100)	6
3.0–30 .....	1842/f	4.89/f	*(900/f <sup>2</sup> )	6
30–300 .....	61.4	0.163	1.0	6
300–1500 .....	.....	.....	f/300	6
1500–100,000 .....	.....	.....	5	6
<b>(B) Limits for General Population/Uncontrolled Exposure</b>				
0.3–1.34 .....	614	1.63	*(100)	30
1.34–30 .....	824/f	2.19/f	*(180/f <sup>2</sup> )	30
30–300 .....	27.5	0.073	0.2	30
300–1500 .....	.....	.....	f/1500	30
1500–100,000 .....	.....	.....	1.0	30

f = frequency in MHz

\* = Plane-wave equivalent power density

NOTE 1 TO TABLE 1: Occupational/controlled limits apply in situations in which persons are exposed as a consequence of their employment provided those persons are fully aware of the potential for exposure and can exercise control over their exposure. Limits for occupational/controlled exposure also apply in situations when an individual is transient through a location where occupational/controlled limits apply provided he or she is made aware of the potential for exposure.

NOTE 2 TO TABLE 1: General population/uncontrolled exposures apply in situations in which the general public may be exposed, or in which persons that are exposed as a consequence of their employment may not be fully aware of the potential for exposure or can not exercise control over their exposure.

### Reference KDB 680106 D01 RF Exposure Wireless Charging App v03

The aggregate H-field strengths at 15 cm surrounding the device and 20 cm above the top surface from all simultaneous transmitting coils are demonstrated to be less than 50% of the MPE limit.

### 2.2 DESCRIPTION OF SUPPORT UNITS

The EUT has been tested with associated equipment below

NO.	PRODUCT	BRAND	MODEL NO.	SERIAL NO.	FCC ID
1	iPhone 15 Pro	Apple	MTQ63CH/A	F43Q7N4Q4H	BCG-E8438A
2	iPhone 11 Pro	Apple	MWDD2CH/A	F17ZMCAMN6YL	N/A

## 2.3 CONFIGURATION OF SYSTEM UNDER TEST

Standby

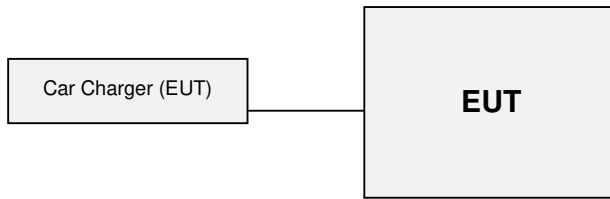

Charging Mode with iPhone 11 Pro

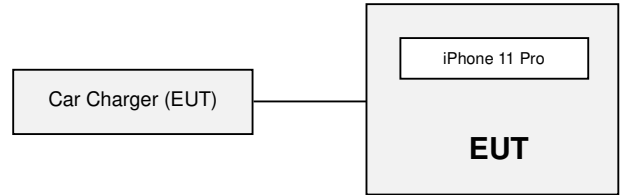

Charging Mode with iPhone 15 Pro

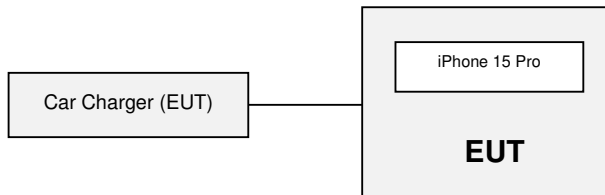

## 2.4 TEST SETUP FOR WPC

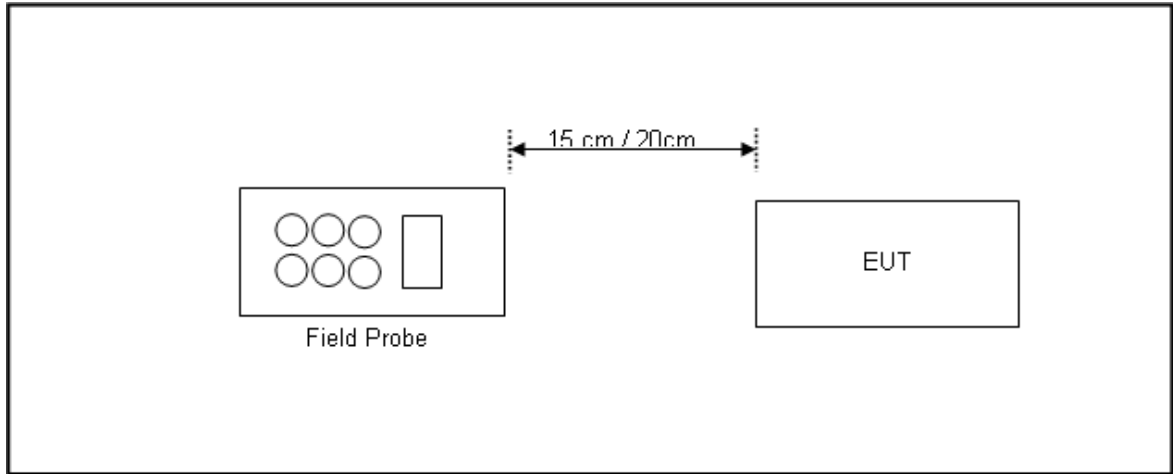

Note: Measurements should be made from all sides and the top of the primary/client pair, with the 15 cm or 20 cm measured from the center of the probe(s) to the edge of the device.

## 2.5 EQUIPMENTS USED DURING TEST

Equipment	Manufacturer	Model No.	Serial No.	Next Cal.
E-Field probe	Narda	NBM-520	2403/01B	Apr. 05, 25
Electric and Magnetic Field Probe-Analyzer	Narda	EHP-200A	180ZX10216	Feb. 19, 25
3m Fully Anechoic Chamber	Chance Most	8m*4m*4m	D3040011DG	May 27, 25
Test Software	Narda	EHP200-TS	V1.94	N/A

**NOTE:**

- The test was performed in RS chamber.
- The calibration interval of the above test instruments is 12 months and the calibrations are traceable to CEPREI/CHINA, GRGT/CHINA and NIM/CHINA.

## 2.6 TEST POINT DESCRIPTION

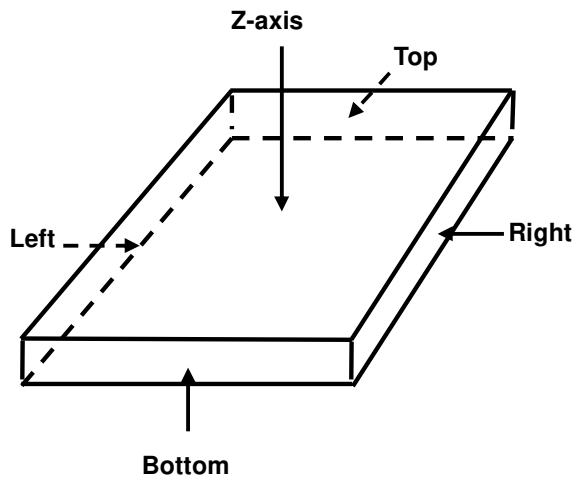



## 2.7 TEST RESULTS

### Mode1 USB-C port input + Standby

E-Field Measurement					
Distance	15cm				20cm
EUT Side	Left	Right	Top	Bottom	Z-axis
Max E-field (V/m)	0.1406	0.1364	0.1157	0.1433	0.1148
Limit (V/m)	614	614	614	614	614
Margin (V/m)	-613.8594	-613.8636	-613.8843	-613.8567	-613.8852
50% Limit (V/m)	307	307	307	307	307
50% Margin (V/m)	-306.8594	-306.8636	-306.8843	-306.8567	-306.8852

H-Field Measurement					
Distance	15cm				20cm
EUT Side	Left	Right	Top	Bottom	Z-axis
Max H-field (A/m)	0.022	0.020	0.021	0.019	0.019
Limit (A/m)	1.63	1.63	1.63	1.63	1.63
Margin (A/m)	-1.608	-1.610	-1.609	-1.611	-1.611
50% Limit (A/m)	0.815	0.815	0.815	0.815	0.815
50% Margin (A/m)	-0.793	-0.795	-0.794	-0.796	-0.796

### Mode2 EUT USB-C port input + iPhone 11 Pro(10% Battery) Charging

E-Field Measurement					
Distance	15cm				20cm
EUT Side	Left	Right	Top	Bottom	Z-axis
Max E-field (V/m)	0.1319	0.1335	0.1849	0.1362	0.1492
Limit (V/m)	614	614	614	614	614
Margin (V/m)	-613.8681	-613.8665	-613.8151	-613.8638	-613.8508
50% Limit (V/m)	307	307	307	307	307
50% Margin (V/m)	-306.8681	-306.8665	-306.8151	-306.8638	-306.8508

H-Field Measurement					
Distance	15cm				20cm
EUT Side	Left	Right	Top	Bottom	Z-axis
Max H-field (A/m)	0.026	0.021	0.050	0.042	0.029
Limit (A/m)	1.63	1.63	1.63	1.63	1.63
Margin (A/m)	-1.605	-1.609	-1.580	-1.588	-1.601
50% Limit (A/m)	0.815	0.815	0.815	0.815	0.815
50% Margin (A/m)	-0.790	-0.794	-0.765	-0.773	-0.786

**Mode3 EUT USB-C port input + iPhone 11 Pro(90% Battery) Charging**

E-Field Measurement					
Distance	15cm				20cm
EUT Side	Left	Right	Top	Bottom	Z-axis
Max E-field (V/m)	0.1237	0.1344	0.2159	0.1863	0.2766
Limit (V/m)	614	614	614	614	614
Margin (V/m)	-613.8763	-613.8656	-613.7841	-613.8137	-613.7234
50% Limit (V/m)	307	307	307	307	307
50% Margin (V/m)	-306.8763	-306.8656	-306.7841	-306.8137	-306.7234

H-Field Measurement					
Distance	15cm				20cm
EUT Side	Left	Right	Top	Bottom	Z-axis
Max H-field (A/m)	0.019	0.021	0.022	0.023	0.035
Limit (A/m)	1.63	1.63	1.63	1.63	1.63
Margin (A/m)	-1.611	-1.609	-1.608	-1.607	-1.595
50% Limit (A/m)	0.815	0.815	0.815	0.815	0.815
50% Margin (A/m)	-0.796	-0.794	-0.793	-0.792	-0.780

**Mode4 EUT USB-C port input + iPhone 15 Pro (10% Battery) Charging**

E-Field Measurement					
Distance	15cm				20cm
EUT Side	Left	Right	Top	Bottom	Z-axis
Max E-field (V/m)	0.1392	0.1474	0.1881	0.1406	0.162
Limit (V/m)	614	614	614	614	614
Margin (V/m)	-613.8608	-613.8526	-613.8119	-613.8594	-613.838
50% Limit (V/m)	307	307	307	307	307
50% Margin (V/m)	-306.8608	-306.8526	-306.8119	-306.8594	-306.838

H-Field Measurement					
Distance	15cm				20cm
EUT Side	Left	Right	Top	Bottom	Z-axis
Max H-field (A/m)	0.021	0.019	0.022	0.019	0.021
Limit (A/m)	1.63	1.63	1.63	1.63	1.63
Margin (A/m)	-1.609	-1.611	-1.608	-1.611	-1.609
50% Limit (A/m)	0.815	0.815	0.815	0.815	0.815
50% Margin (A/m)	-0.794	-0.796	-0.793	-0.796	-0.794

**Mode5 EUT USB-C port input + iPhone 15 Pro (90% Battery) Charging**

E-Field Measurement					
Distance	15cm				20cm
EUT Side	Left	Right	Top	Bottom	Z-axis
Max E-field (V/m)	0.2159	0.2237	0.2796	0.2493	0.3155
Limit (V/m)	614	614	614	614	614
Margin (V/m)	-613.7841	-613.7763	-613.7204	-613.7507	-613.6845
50% Limit (V/m)	307	307	307	307	307
50% Margin (V/m)	-306.7841	-306.7763	-306.7204	-306.7507	-306.6845

H-Field Measurement					
Distance	15cm				20cm
EUT Side	Left	Right	Top	Bottom	Z-axis
Max H-field (A/m)	0.032	0.032	0.033	0.025	0.020
Limit (A/m)	1.63	1.63	1.63	1.63	1.63
Margin (A/m)	-1.598	-1.598	-1.597	-1.605	-1.610
50% Limit (A/m)	0.815	0.815	0.815	0.815	0.815
50% Margin (A/m)	-0.783	-0.783	-0.782	-0.790	-0.795



Test Report No.: FM2405WDG0029

### 3. PHOTOGRAPHS OF THE TEST CONFIGURATION

Please refer to the attached file (Test Setup Photo).

--- END ---