

Variant FCC Test Report (Wireless Charger)

Report No.: RF191202C10B

FCC ID: K7SG1S0001

Test Model: G1S0001

Series Model: G1S0002

Received Date: Jun. 19, 2020

Test Date: Jul. 07 ~ Aug. 12, 2020

Issued Date: Aug. 17, 2020

Applicant: Belkin International, Inc

Address: 12045 East Waterfront Drive, Playa Vista, USA, CA 90094

Issued By: Bureau Veritas Consumer Products Services (H.K.) Ltd., Taoyuan Branch

Lab Address: No. 47-2, 14th Ling, Chia Pau Vil., Lin Kou Dist., New Taipei City, Taiwan

Test Location: No. 19, Hwa Ya 2nd Rd, Wen Hwa Tsuen, Kwei Shan Hsiang, Taoyuan Hsien 333, Taiwan

**FCC Registration /
Designation Number:** 788550 / TW0003



This report is for your exclusive use. Any copying or replication of this report to or for any other person or entity, or use of our name or trademark, is permitted only with our prior written permission. This report sets forth our findings solely with respect to the test samples identified herein. The results set forth in this report are not indicative or representative of the quality or characteristics of the lot from which a test sample was taken or any similar or identical product unless specifically and expressly noted. Our report includes all of the tests requested by you and the results thereof based upon the information that you provided to us. You have 60 days from date of issuance of this report to notify us of any material error or omission caused by our negligence, provided, however, that such notice shall be in writing and shall specifically address the issue you wish to raise. A failure to raise such issue within the prescribed time shall constitute your unqualified acceptance of the completeness of this report, the tests conducted and the correctness of the report contents. Unless specific mention, the uncertainty of measurement has been explicitly taken into account to declare the compliance or non-compliance to the specification.

Table of Contents

Release Control Record	3
1 Certificate of Conformity	4
2 Summary of Test Results.....	5
2.1 Measurement Uncertainty.....	5
2.2 Modification Record	5
3 General Information	6
3.1 General Description of EUT	6
3.2 Description of Test Modes.....	7
3.2.1 Test Mode Applicability and Tested Channel Detail.....	7
3.3 Description of Support Units	8
3.3.1 Configuration of System under Test	8
3.4 General Description of Applied Standards.....	8
4 Test Types and Results	9
4.1 Radiated Emission and Bandedge Measurement	9
4.1.1 Limits of Radiated Emission and Bandedge Measurement	9
4.1.2 Test Instruments	10
4.1.3 Test Procedures.....	11
4.1.4 Deviation from Test Standard	11
4.1.5 Test Setup.....	12
4.1.6 EUT Operating Conditions.....	12
4.1.7 Test Results	13
4.2 Conducted Emission Measurement.....	17
4.2.1 Limits of Conducted Emission Measurement	17
4.2.2 Test Instruments	17
4.2.3 Test Procedures.....	18
4.2.4 Deviation from Test Standard	18
4.2.5 Test Setup.....	18
4.2.6 EUT Operating Conditions.....	18
4.2.7 Test Results	19
5 Pictures of Test Arrangements.....	23
Appendix – Information of the Testing Laboratories	24

Release Control Record

Issue No.	Description	Date Issued
RF191202C10B	Original Release	Aug. 17, 2020

1 Certificate of Conformity

Product: Smart Speaker
Brand: belkin
Test Model: G1S0001
Series Model: G1S0002
Sample Status: Engineering Sample
Applicant: Belkin International, Inc
Test Date: Jul. 07 ~ Aug. 12, 2020
Standards: 47 CFR FCC Part 15, Subpart C (Section 15.209)
ANSI C63.10: 2013

The above equipment has been tested by **Bureau Veritas Consumer Products Services (H.K.) Ltd., Taoyuan Branch**, and found compliance with the requirement of the above standards. The test record, data evaluation & Equipment Under Test (EUT) configurations represented herein are true and accurate accounts of the measurements of the sample's RF characteristics under the conditions specified in this report.

Prepared by : , **Date:** Aug. 17, 2020
Gina Liu / Specialist

Approved by : , **Date:** Aug. 17, 2020
Dylan Chiou / Senior Project Engineer

2 Summary of Test Results

47 CFR FCC Part 15, Subpart C (Section 15.209)			
FCC Clause	Test Item	Result	Remarks
15.207	Conducted emission test	Pass	Meet the requirement of limit. Minimum passing margin is -20.27 dB at 4.67387 MHz.
15.209	Radiated emission test	Pass	Meet the requirement of limit. Minimum passing margin is -8.16 dB at 36.79 MHz.

Note: Determining compliance based on the results of the compliance measurement, not taking into account measurement instrumentation uncertainty.

2.1 Measurement Uncertainty

Where relevant, the following measurement uncertainty levels have been estimated for tests performed on the EUT as specified in CISPR 16-4-2:

Measurement	Frequency	Expanded Uncertainty (k=2) (±)
Conducted Emissions at mains ports	150 kHz ~ 30 MHz	2.79 dB
Radiated Emissions up to 1 GHz	9 kHz ~ 30 MHz	3.04 dB
	30 MHz ~ 200 MHz	2.93 dB
	200 MHz ~ 1000 MHz	2.95 dB

2.2 Modification Record

There were no modifications required for compliance.

3 General Information

3.1 General Description of EUT

Product	Smart Speaker
Brand	belkin
Test Model	G1S0001
Series Model	G1S0002
Status of EUT	Engineering Sample
Power Supply Rating	19.0 Vdc (Adapter)
Modulation Type	FSK
Operating Frequency	127.7 kHz
Dimension for Charging Coil	39.5 * 47.5 mm
Antenna Type	Coil Antenna
Accessory Device	Adapter
Data Cable Supplied	N/A
Maximum Power Output for Charging Coil	10 W

Note:

- This report is prepared for FCC class II permissive change. This report is issued as a supplementary report of BV CPS report no.: RF191202C10. Difference compared with original report is listed as below. Therefore, test items for conducted emission and radiated emission 30MHz~1GHz test had been re-tested in this report.

No.	Description
1.	Adding MF chip (Brand: Microchip; Model: MFI343S00177)
2.	System changed to support Alexa Voice Service+Airplay 2
3.	Adding new model (G1S0002)

- The EUT contains following accessory devices.

Product	Brand	Model	Description
Switching Adapter	belkin	DSA-65PFB-19 FUS 190342	I/P: 100-240 Vac, 50/60 Hz, 1.5 A O/P: 19 Vdc, 3.42 A 1.45 meter, non-shielded cable, with one ferrite core

- The EUT have the three charging rate (10%, 50%, 90%). After pre-tested all the charging rate and found charging 10% was the worst. Therefore only charging 10% was for the final test and presented in the test.
- The above EUT information is declared by manufacturer and for more detailed features description, please refers to the manufacturer's specifications or user's manual.

3.2 Description of Test Modes

1 channel is provided to this EUT:

Channel	Frequency (kHz)
1	127.7

3.2.1 Test Mode Applicability and Tested Channel Detail

EUT Configure Mode	Applicable To		Description
	RE<1G	PLC	
-	√	√	-

Where **RE<1G**: Radiated Emission below 1 GHz **PLC**: Power Line Conducted Emission

Radiated Emission Test (Below 1 GHz):

- Pre-Scan has been conducted to determine the worst-case mode from all possible combinations between available modulations, data rates and antenna ports (if EUT with antenna diversity architecture).
- Following channel(s) was (were) selected for the final test as listed below.

EUT Configure Mode	Available Channel	Tested Channel
-	1	1

Power Line Conducted Emission Test:

- Pre-Scan has been conducted to determine the worst-case mode from all possible combinations between available modulations, data rates and antenna ports (if EUT with antenna diversity architecture).
- Following channel(s) was (were) selected for the final test as listed below.

EUT Configure Mode	Available Channel	Tested Channel
-	1	1

Test Condition:

Applicable To	Environmental Conditions	Input Power	Tested By
RE	25 deg. C, 65 % RH	120 Vac, 60 Hz	Jisyong Wang
PLC	25 deg. C, 65 % RH	120 Vac, 60 Hz	Jisyong Wang

3.3 Description of Support Units

The EUT has been tested as an independent unit together with other necessary accessories or support units. The following support units or accessories were used to form a representative test configuration during the tests.

No.	Product	Brand	Model No.	Serial No.	FCC ID	Remarks
A.	Load	N/A	N/A	N/A	N/A	Provided by manufacturer (10W max load)

Note: Item A was provided by client

3.3.1 Configuration of System under Test

Charging Mode

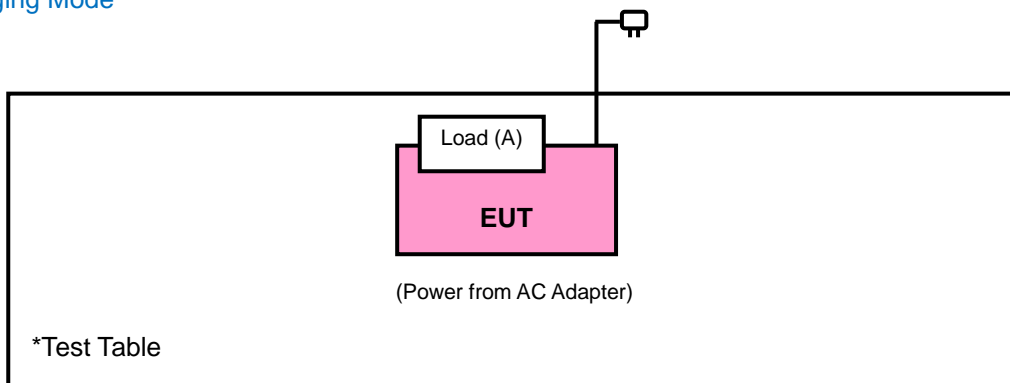

Standby Mode

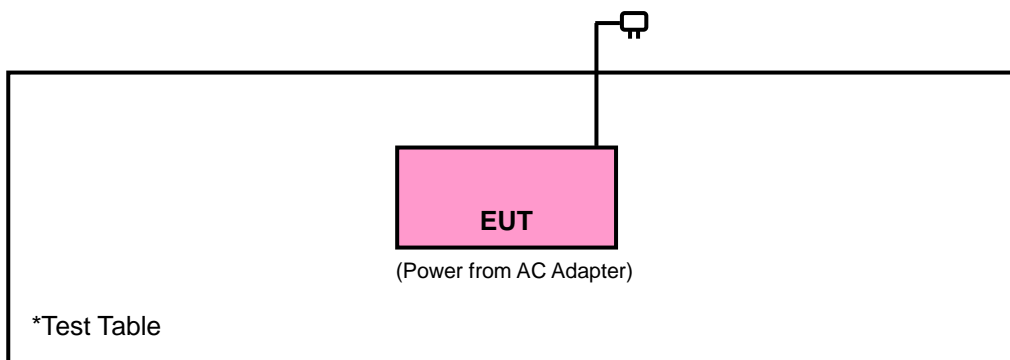

3.4 General Description of Applied Standards

The EUT is a RF Product. According to the specifications of the manufacturer, it must comply with the requirements of the following standards:

FCC Part 15, Subpart C (15.209)

ANSI C63.10-2013

All test items have been performed and recorded as per the above standards.

4 Test Types and Results

4.1 Radiated Emission and Bandedge Measurement

4.1.1 Limits of Radiated Emission and Bandedge Measurement

For Frequency Below 30MHz

Frequency (MHz)	Field Strength (dBuV/m)		Measurement Distance (meters)
	uV/m	dBuV/m	
0.009 – 0.490	2400 / F (kHz)	48.52-13.80	300
0.490 – 1.705	24000 / F (kHz)	33.80-22.97	30
1.705 – 30.0	30	29.54	30

For Frequency Between 30-1000MHz

Frequency (MHz)	Class A (at 10m)		Class B (at 3m)	
	uV/m	dBuV/m	uV/m	dBuV/m
30-88	90	39.1	100	40.0
88-216	150	43.5	150	43.5
216-960	210	46.4	200	46.0
Above 960	300	49.5	500	54.0

4.1.2 Test Instruments

Description & Manufacturer	Model No.	Serial No.	Date of Calibration	Due Date of Calibration
Test Receiver Agilent	N9038A	MY51210203	Mar. 18, 2020	Mar. 17, 2021
Spectrum Analyzer Agilent	N9010A	MY52220314	Dec. 12, 2019	Dec. 11, 2020
Spectrum Analyzer ROHDE & SCHWARZ	FSU43	101261	Apr. 16, 2020	Apr. 15, 2021
BILOG Antenna SCHWARZBECK	VULB 9168	9168-472	Nov. 08, 2019	Nov. 07, 2020
Fixed Attenuator WOKEN	MDCS18N-10	MDCS18N-10-01	Apr. 14, 2020	Apr. 13, 2021
Loop Antenna TESEQ	HLA 6121	45745	Jul. 06, 2020	Jul. 05, 2021
Preamplifier EMCI	EMC001340	980201	Oct. 14, 2019	Oct. 13, 2020
Preamplifier EMCI	EMC 330H	980112	Oct. 08, 2019	Oct. 07, 2020
RF Coaxial Cable WOKEN	8D-FB	Cable-Ch10-01	Oct. 08, 2019	Oct. 07, 2020
Boresight Antenna Fixture	FBA-01	FBA-SIP01	NA	NA
Software BV ADT	E3 6.120103	NA	NA	NA
Antenna Tower MF	MFA-440H	NA	NA	NA
Turn Table MF	MFT-201SS	NA	NA	NA
Antenna Tower & Turn Table Controller MF	MF-7802	NA	NA	NA

- Note: 1. The calibration interval of the above test instruments is 12 months and the calibrations are traceable to NML/ROC and NIST/USA.
2. The test was performed in HwaYa Chamber 10.

4.1.3 Test Procedures

For Radiated Emission below 30 MHz

- a. The EUT was placed on the top of a rotating table 0.8 meters above the ground at a 3 meter chamber room. The table was rotated 360 degrees to determine the position of the highest radiation.
- b. The EUT was set 3 meters away from the interference-receiving antenna, which was mounted on the top of a variable-height antenna tower.
- c. Both Parallel, perpendicular, and ground-parallel orientations of the antenna are set to make the measurement.
- d. For each suspected emission, the EUT was arranged to its worst case and the rotatable table was turned from 0 degrees to 360 degrees to find the maximum reading.
- e. The test-receiver system was set to Quasi-Peak Detect Function, set the frequency band (9-90kHz, 110-490kHz) for Average Detect Function, and Specified Bandwidth with Maximum Hold Mode.

Note:

1. The resolution bandwidth and video bandwidth of test receiver/spectrum analyzer is for 9kHz to 150kHz, set RBW=200Hz & 150kHz to 30MHz, set RBW=9kHz at frequency below 30 MHz.
2. There is a comparison data of both open-field test site and semi-Anechoic chamber, and the result came out very similar.

For Radiated Emission above 30 MHz

- a. The EUT was placed on the top of a rotating table 0.8 meters above the ground at 3 meter chamber room for test. The table was rotated 360 degrees to determine the position of the highest radiation.
- b. The EUT was set 3 meters away from the interference-receiving antenna, which was mounted on the top of a variable-height antenna tower.
- c. The height of antenna is varied from one meter to four meters above the ground to determine the maximum value of the field strength. Both horizontal and vertical polarizations of the antenna are set to make the measurement.
- d. For each suspected emission, the EUT was arranged to its worst case and then the antenna was tuned to heights from 1 meter to 4 meters and the rotatable table was turned from 0 degrees to 360 degrees to find the maximum reading.
- e. The test-receiver system was set to quasi-peak detect function and specified bandwidth with maximum hold mode when the test frequency is below 1 GHz.
- f. The test-receiver system was set to peak and average detected function and specified bandwidth with maximum hold mode when the test frequency is above 1 GHz. If the peak reading value also meets average limit, measurement with the average detector is unnecessary.

Note:

1. The resolution bandwidth and video bandwidth of test receiver/spectrum analyzer is 120 kHz for Quasi-peak detection (QP) or Peak detection (PK) at frequency below 1 GHz.
2. The resolution bandwidth of test receiver/spectrum analyzer is 1 MHz and the video bandwidth is 3 MHz for Peak detection (PK) at frequency above 1 GHz.
3. The resolution bandwidth of test receiver/spectrum analyzer is 1 MHz and the video bandwidth is $\geq 1/T$ (Duty cycle < 98 %) or 10 Hz (Duty cycle ≥ 98 %) for Average detection (AV) at frequency above 1 GHz.
4. All modes of operation were investigated and the worst-case emissions are reported.

4.1.4 Deviation from Test Standard

No deviation.

4.1.5 Test Setup

<Radiated Emission below 30 MHz>

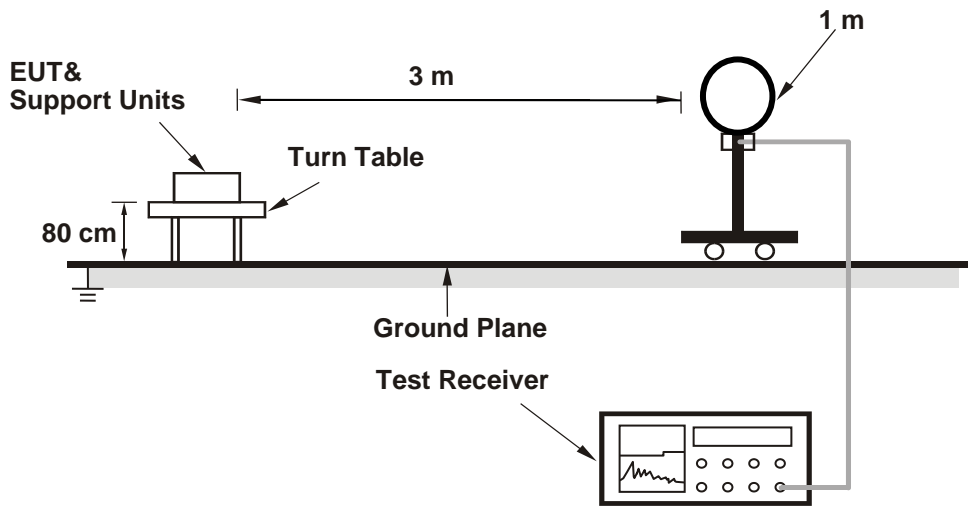

<Radiated Emission 30 MHz to 1 GHz>

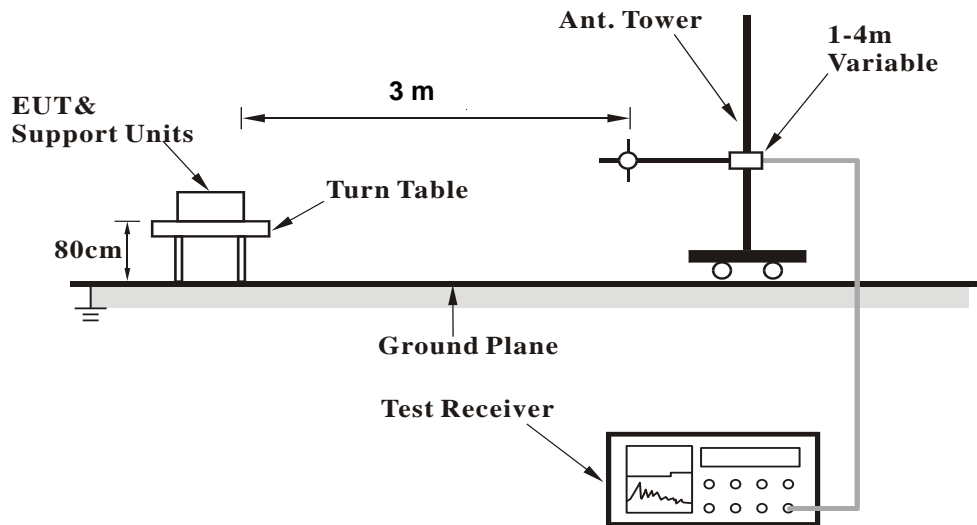

For the actual test configuration, please refer to the attached file (Test Setup Photo).

4.1.6 EUT Operating Conditions

Test Mode A

- a. The EUT powered by adapter.
- b. Put the load on the EUT (wireless charging) during the test.

Test Mode B

- a. The EUT powered by adapter.

4.1.7 Test Results

Below 1GHz Data:
Charging Mode

EUT Test Condition		Measurement Detail	
Input Power	120 Vac, 60 Hz	Frequency Range	30 MHz ~ 1000 MHz
Environmental Conditions	25 deg. C, 65 % RH	Detector Function	Quasi-peak (QP) Peak (PK)
Tested By	Jisyong Wang		

Horizontal

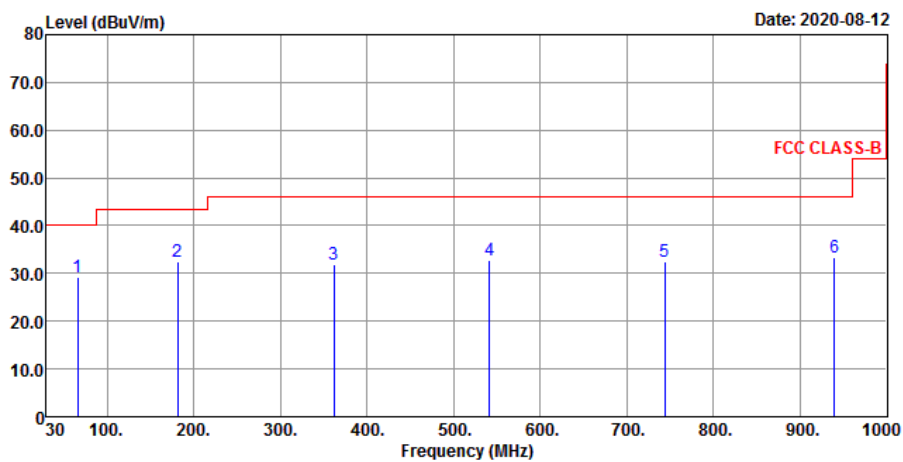

Vertical

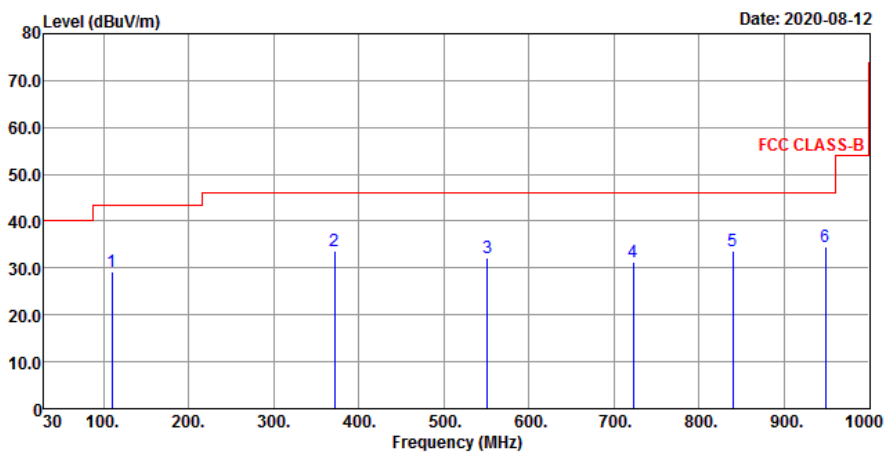

Antenna Polarity & Test Distance: Horizontal at 3 m

Frequency (MHz)	Emission Level (dBuV/m)	Read Level (dBuV)	Factor (dB/m)	Limit (dBuV/m)	Margin (dB)	Antenna Height (cm)	Table Angle (Degree)	Remark
65.89	29.34	42.72	-13.38	40	-10.66	169	202	QP
181.32	32.35	45.93	-13.58	43.5	-11.15	183	204	QP
361.74	31.99	41.34	-9.35	46	-14.01	188	36	QP
541.19	32.8	37.51	-4.71	46	-13.2	123	188	QP
743.92	32.5	31.57	0.93	46	-13.5	106	53	QP
939.86	33.43	29.95	3.48	46	-12.57	102	103	QP

Antenna Polarity & Test Distance: Vertical at 3 m

Frequency (MHz)	Emission Level (dBuV/m)	Read Level (dBuV)	Factor (dB/m)	Limit (dBuV/m)	Margin (dB)	Antenna Height (cm)	Table Angle (Degree)	Remark
109.54	29.29	43.99	-14.7	43.5	-14.21	157	226	QP
371.44	33.57	42.53	-8.96	46	-12.43	136	135	QP
550.89	32.29	36.73	-4.44	46	-13.71	192	248	QP
722.58	31.31	31.41	-0.1	46	-14.69	117	65	QP
839.95	33.62	31.23	2.39	46	-12.38	143	53	QP
948.59	34.44	30.76	3.68	46	-11.56	178	122	QP

Remarks:

1. Emission Level = Read Level + Factor
2. Margin value = Emission level – Limit value.
3. The other emission levels were very low against the limit.

Standby Mode

EUT Test Condition		Measurement Detail	
Input Power	120 Vac, 60 Hz	Frequency Range	30 MHz ~ 1000 MHz
Environmental Conditions	25 deg. C, 65 % RH	Detector Function	Quasi-peak (QP) Peak (PK)
Tested By	Jisyong Wang		

Horizontal

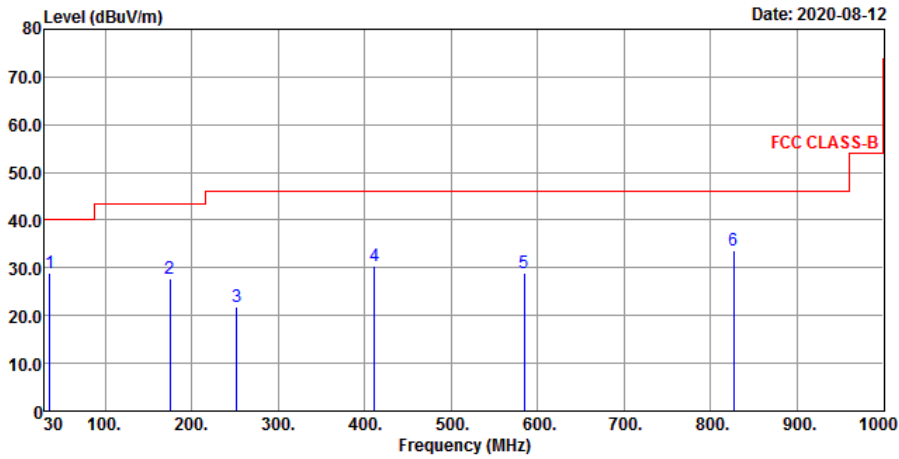

Vertical

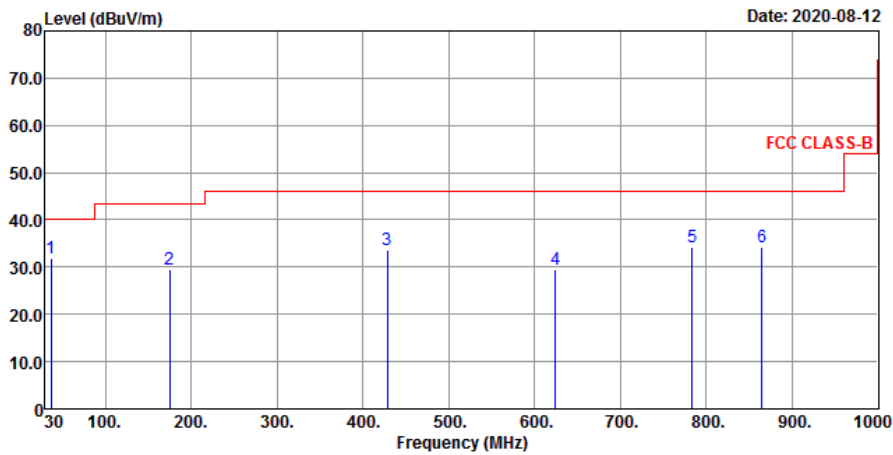

Antenna Polarity & Test Distance: Horizontal at 3 m

Frequency (MHz)	Emission Level (dBuV/m)	Read Level (dBuV)	Factor (dB/m)	Limit (dBuV/m)	Margin (dB)	Antenna Height (cm)	Table Angle (Degree)	Remark
35.82	29.06	41.81	-12.75	40	-10.94	145	132	QP
174.53	27.85	40.58	-12.73	43.5	-15.65	111	192	QP
252.13	21.86	34.82	-12.96	46	-24.14	185	245	QP
411.21	30.53	38.56	-8.03	46	-15.47	132	214	QP
584.84	28.83	32.04	-3.21	46	-17.17	102	265	QP
826.37	33.67	31.45	2.22	46	-12.33	147	152	QP

Antenna Polarity & Test Distance: Vertical at 3 m

Frequency (MHz)	Emission Level (dBuV/m)	Read Level (dBuV)	Factor (dB/m)	Limit (dBuV/m)	Margin (dB)	Antenna Height (cm)	Table Angle (Degree)	Remark
36.79	31.84	44.38	-12.54	40	-8.16	132	165	QP
174.53	29.56	42.29	-12.73	43.5	-13.94	147	152	QP
428.67	33.72	40.87	-7.15	46	-12.28	102	285	QP
624.61	29.57	31.48	-1.91	46	-16.43	198	165	QP
783.69	34.23	32.68	1.55	46	-11.77	111	145	QP
865.17	34.23	31.62	2.61	46	-11.77	102	231	QP

Remarks:

1. Emission Level = Read Level + Factor
2. Margin value = Emission level – Limit value.
3. The other emission levels were very low against the limit.

4.2 Conducted Emission Measurement

4.2.1 Limits of Conducted Emission Measurement

Frequency (MHz)	Conducted Limit (dBuV)	
	Quasi-Peak	Average
0.15 - 0.5	66 - 56	56 - 46
0.50 - 5.0	56	46
5.0 - 30.0	60	50

Note:

1. The lower limit shall apply at the transition frequencies.
2. The limit decreases in line with the logarithm of the frequency in the range of 0.15 to 0.50 MHz.
3. All emanations from a class A/B digital device or system, including any network of conductors and apparatus connected thereto, shall not exceed the level of field strengths specified above.

4.2.2 Test Instruments

Description & Manufacturer	Model No.	Serial No.	Date of Calibration	Due Date of Calibration
Test Receiver ROHDE & SCHWARZ	ESCI	100613	Dec. 11, 2019	Dec. 10, 2020
RF signal cable Woken	5D-FB	Cable-cond1-01	Sep. 05, 2019	Sep. 04, 2020
LISN ROHDE & SCHWARZ (EUT)	ENV216	101826	Feb. 20, 2020	Feb. 19, 2021
LISN ROHDE & SCHWARZ (Peripheral)	ESH3-Z5	100311	Aug. 22, 2019	Aug. 21, 2020
Software ADT	BV ADT_Cond_ V7.3.7.4	NA	NA	NA

- Note:
1. The calibration interval of the above test instruments is 12 months and the calibrations are traceable to NML/ROC and NIST/USA.
 2. The test was performed in HwaYa Shielded Room 1.
 3. The VCCI Site Registration No. is C-12040.

4.2.3 Test Procedures

- a. The EUT was placed 0.4 meters from the conducting wall of the shielded room with EUT being connected to the power mains through a line impedance stabilization network (LISN). Other support units were connected to the power mains through another LISN. The two LISNs provide 50 ohm/ 50 uH of coupling impedance for the measuring instrument.
- b. Both lines of the power mains connected to the EUT were checked for maximum conducted interference.
- c. The frequency range from 150 kHz to 30 MHz was searched. Emission levels under (Limit – 20 dB) was not recorded.

NOTE: The resolution bandwidth and video bandwidth of test receiver is 9 kHz for quasi-peak detection (QP) and average detection (AV) at frequency 0.15 MHz - 30 MHz.

4.2.4 Deviation from Test Standard

No deviation.

4.2.5 Test Setup

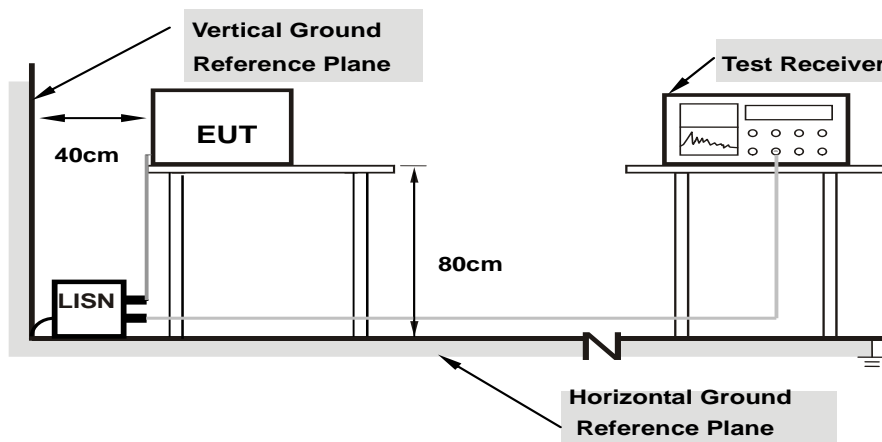

Note: 1.Support units were connected to second LISN.

For the actual test configuration, please refer to the attached file (Test Setup Photo).

4.2.6 EUT Operating Conditions

Same as 4.1.6.

4.2.7 Test Results

Charging Mode

Frequency Range	150kHz ~ 30MHz	Detector Function & Resolution Bandwidth	Quasi-Peak (QP) / Average (AV), 9kHz
Input Power	120Vac, 60Hz	Environmental Conditions	25°C, 65%RH
Tested by	Jisyong Wang	Test Date	2020/7/7

Phase Of Power : Line (L)										
No	Frequency (MHz)	Correction Factor (dB)	Reading Value (dBuV)		Emission Level (dBuV)		Limit (dBuV)		Margin (dB)	
			Q.P.	AV.	Q.P.	AV.	Q.P.	AV.	Q.P.	AV.
1	0.16564	9.63	25.11	20.47	34.74	30.10	65.18	55.18	-30.44	-25.08
2	0.18122	9.62	22.57	20.57	32.19	30.19	64.43	54.43	-32.24	-24.24
3	0.23602	9.63	18.09	16.27	27.72	25.90	62.24	52.24	-34.52	-26.34
4	0.48235	9.65	13.67	11.30	23.32	20.95	56.30	46.30	-32.98	-25.35
5	4.67387	9.80	16.78	15.93	26.58	25.73	56.00	46.00	-29.42	-20.27
6	11.69232	9.88	8.78	5.41	18.66	15.29	60.00	50.00	-41.34	-34.71

Remarks:

1. Q.P. and AV. are abbreviations of quasi-peak and average individually.
2. The emission levels of other frequencies were very low against the limit.
3. Margin value = Emission level – Limit value
4. Correction factor = Insertion loss + Cable loss
5. Emission Level = Correction Factor + Reading Value

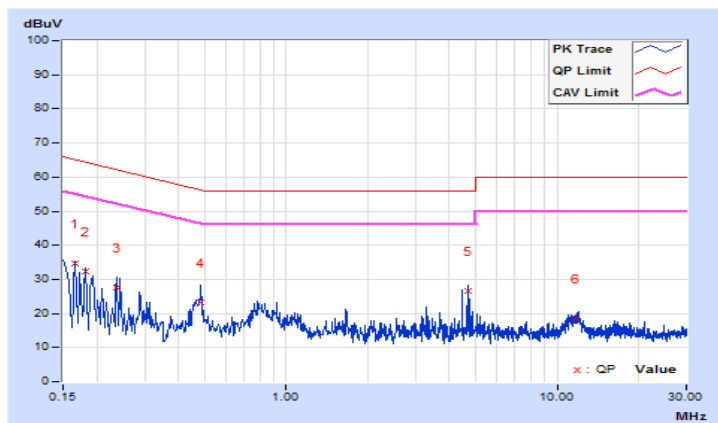

Frequency Range	150kHz ~ 30MHz	Detector Function & Resolution Bandwidth	Quasi-Peak (QP) / Average (AV), 9kHz
Input Power	120Vac, 60Hz	Environmental Conditions	25°C, 65%RH
Tested by	Jisyong Wang	Test Date	2020/7/7

Phase Of Power : Neutral (N)										
No	Frequency (MHz)	Correction Factor (dB)	Reading Value (dBuV)		Emission Level (dBuV)		Limit (dBuV)		Margin (dB)	
			Q.P.	AV.	Q.P.	AV.	Q.P.	AV.	Q.P.	AV.
1	0.16955	9.65	25.42	20.57	35.07	30.22	64.98	54.98	-29.91	-24.76
2	0.21256	9.64	20.77	18.01	30.41	27.65	63.10	53.10	-32.69	-25.45
3	0.46280	9.67	15.23	13.34	24.90	23.01	56.64	46.64	-31.74	-23.63
4	0.80297	9.69	11.53	10.57	21.22	20.26	56.00	46.00	-34.78	-25.74
5	1.57715	9.73	7.16	6.01	16.89	15.74	56.00	46.00	-39.11	-30.26
6	4.57221	9.83	18.45	11.74	28.28	21.57	56.00	46.00	-27.72	-24.43

Remarks:

1. Q.P. and AV. are abbreviations of quasi-peak and average individually.
2. The emission levels of other frequencies were very low against the limit.
3. Margin value = Emission level – Limit value
4. Correction factor = Insertion loss + Cable loss
5. Emission Level = Correction Factor + Reading Value

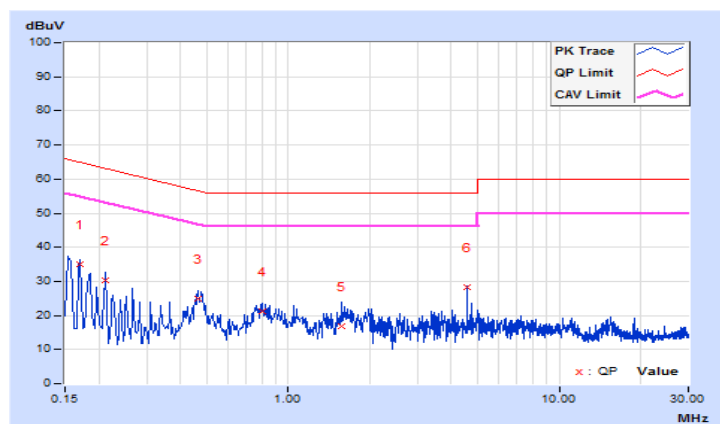

Standby Mode

Frequency Range	150kHz ~ 30MHz	Detector Function & Resolution Bandwidth	Quasi-Peak (QP) / Average (AV), 9kHz
Input Power	120Vac, 60Hz	Environmental Conditions	25°C, 65%RH
Tested by	Jisyong Wang	Test Date	2020/7/7

Phase Of Power : Line (L)										
No	Frequency (MHz)	Correction Factor (dB)	Reading Value (dBuV)		Emission Level (dBuV)		Limit (dBuV)		Margin (dB)	
			Q.P.	AV.	Q.P.	AV.	Q.P.	AV.	Q.P.	AV.
1	0.18128	9.62	24.89	20.99	34.51	30.61	64.43	54.43	-29.92	-23.82
2	0.21256	9.62	20.81	15.06	30.43	24.68	63.10	53.10	-32.67	-28.42
3	0.22429	9.62	18.47	13.37	28.09	22.99	62.66	52.66	-34.57	-29.67
4	0.28214	9.63	13.39	10.48	23.02	20.11	60.75	50.75	-37.73	-30.64
5	0.79124	9.67	9.77	4.48	19.44	14.15	56.00	46.00	-36.56	-31.85
6	4.67387	9.80	14.57	13.15	24.37	22.95	56.00	46.00	-31.63	-23.05

Remarks:

1. Q.P. and AV. are abbreviations of quasi-peak and average individually.
2. The emission levels of other frequencies were very low against the limit.
3. Margin value = Emission level – Limit value
4. Correction factor = Insertion loss + Cable loss
5. Emission Level = Correction Factor + Reading Value

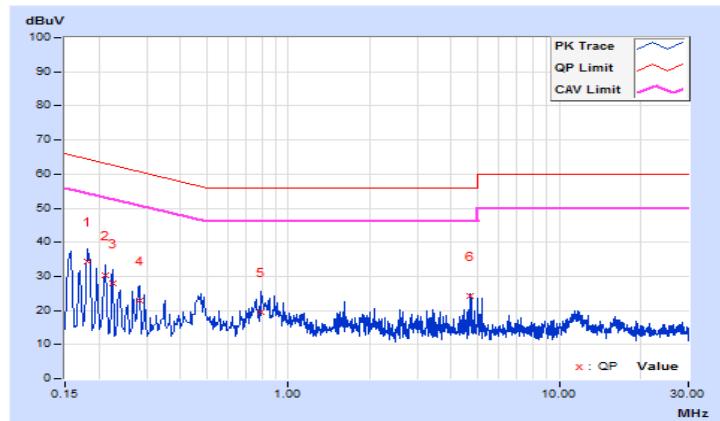

Frequency Range	150kHz ~ 30MHz	Detector Function & Resolution Bandwidth	Quasi-Peak (QP) / Average (AV), 9kHz
Input Power	120Vac, 60Hz	Environmental Conditions	25°C, 65%RH
Tested by	Jisyong Wang	Test Date	2020/7/7

Phase Of Power : Neutral (N)										
No	Frequency (MHz)	Correction Factor (dB)	Reading Value (dBuV)		Emission Level (dBuV)		Limit (dBuV)		Margin (dB)	
			Q.P.	AV.	Q.P.	AV.	Q.P.	AV.	Q.P.	AV.
1	0.16564	9.65	26.16	20.51	35.81	30.16	65.18	55.18	-29.37	-25.02
2	0.18122	9.65	24.75	20.70	34.40	30.35	64.43	54.43	-30.03	-24.08
3	0.22038	9.64	20.13	13.62	29.77	23.26	62.80	52.80	-33.03	-29.54
4	0.48626	9.67	13.84	10.20	23.51	19.87	56.23	46.23	-32.72	-26.36
5	4.67387	9.83	16.88	13.48	26.71	23.31	56.00	46.00	-29.29	-22.69
6	14.96108	9.98	6.94	3.00	16.92	12.98	60.00	50.00	-43.08	-37.02

Remarks:

1. Q.P. and AV. are abbreviations of quasi-peak and average individually.
2. The emission levels of other frequencies were very low against the limit.
3. Margin value = Emission level – Limit value
4. Correction factor = Insertion loss + Cable loss
5. Emission Level = Correction Factor + Reading Value

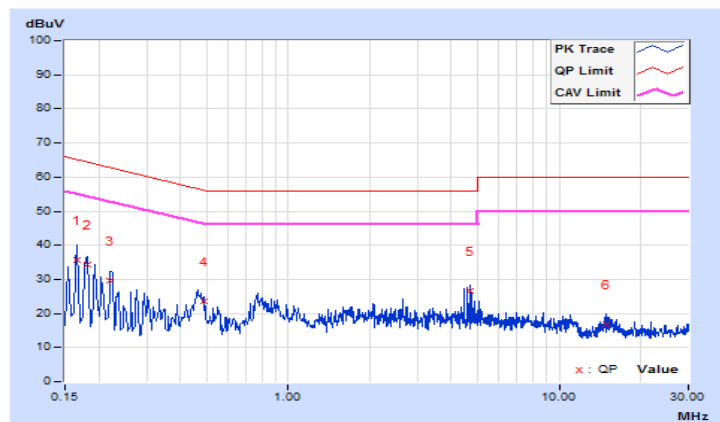

5 Pictures of Test Arrangements

Please refer to the attached file (Test Setup Photo).

Appendix – Information of the Testing Laboratories

We, Bureau Veritas Consumer Products Services (H.K.) Ltd., Taoyuan Branch, were founded in 1988 to provide our best service in EMC, Radio, Telecom and Safety consultation. Our laboratories are FCC recognized accredited test firms and accredited according to ISO/IEC 17025.

If you have any comments, please feel free to contact us at the following:

Lin Kou EMC/RF Lab

Tel: 886-2-26052180

Fax: 886-2-26051924

Hsin Chu EMC/RF/Telecom Lab

Tel: 886-3-6668565

Fax: 886-3-6668323

Hwa Ya EMC/RF/Safety Lab

Tel: 886-3-3183232

Fax: 886-3-3270892

Email: service.adt@tw.bureauveritas.com

Web Site: www.bureauveritas-adt.com

The address and road map of all our labs can be found in our web site also.

--- END ---