

FCC Test Report

Report No.: RF160321D09B

FCC ID: K7SF9K1124V1

Test Model: F9K1124V1

Series Model: F9K1119V2

Received Date: Jun. 28, 2016

Test Date: Jun. 28 ~ Jul. 4, 2016

Issued Date: Jul. 28, 2016

Applicant: Belkin International, Inc.

Address: 12045 East Waterfront Drive, Playa Vista, CA 90094 USA

Issued By: Bureau Veritas Consumer Products Services (H.K.) Ltd., Taoyuan Branch

Lab Address: No. 47-2, 14th Ling, Chia Pau Vil., Lin Kou Dist., New Taipei City, Taiwan (R.O.C.)



This report is for your exclusive use. Any copying or replication of this report to or for any other person or entity, or use of our name or trademark, is permitted only with our prior written permission. This report sets forth our findings solely with respect to the test samples identified herein. The results set forth in this report are not indicative or representative of the quality or characteristics of the lot from which a test sample was taken or any similar or identical product unless specifically and expressly noted. Our report includes all of the tests requested by you and the results thereof based upon the information that you provided to us. You have 60 days from date of issuance of this report to notify us of any material error or omission caused by our negligence, provided, however, that such notice shall be in writing and shall specifically address the issue you wish to raise. A failure to raise such issue within the prescribed time shall constitute your unqualified acceptance of the completeness of this report, the tests conducted and the correctness of the report contents. Unless specifically mentioned, the uncertainty of measurement has been explicitly taken into account to declare the compliance or non-compliance to the specification. The report must not be used by the client to claim product certification, approval, or endorsement by TAF or any government agencies.

Table of Contents

Report Issue History Record	4
Release Control Record.....	4
1 Certificate of Conformity	5
2 Summary of Test Results	6
2.1 Measurement Uncertainty.....	6
2.2 Modification Record.....	6
3 General Information.....	7
3.1 General Description of EUT.....	7
3.2 Description of Test Modes	10
3.2.1 Test Mode Applicability and Tested Channel Detail.....	11
3.3 Duty Cycle of Test Signal.....	13
3.4 Description of Support Units.....	14
3.4.1 Configuration of System under Test	15
3.5 General Description of Applied Standard	16
4 Test Types and Results.....	17
4.1 Radiated Emission and Bandedge Measurement.....	17
4.1.1 Limits of Radiated Emission and Bandedge Measurement.....	17
4.1.2 Test Instruments.....	18
4.1.3 Test Procedure	19
4.1.4 Deviation from Test Standard	19
4.1.5 Test Setup	20
4.1.6 EUT Operating Condition.....	20
4.1.7 Test Results.....	21
4.2 Conducted Emission Measurement	31
4.2.1 Limits of Conducted Emission Measurement.....	31
4.2.2 Test Instruments.....	31
4.2.3 Test Procedure	32
4.2.4 Deviation from Test Standard	32
4.2.5 Test Setup	32
4.2.6 EUT Operating Condition.....	32
4.2.7 Test Results.....	33
4.3 Transmit Power Measurement.....	35
4.3.1 Limits of Transmit Power Measurement	35
4.3.2 Test Setup	35
4.3.3 Test Instruments.....	35
4.3.4 Test Procedure	36
4.3.5 Deviation from Test Standard	36
4.3.6 EUT Operating Condition.....	36
4.3.7 Test Result	37
4.4 Occupied Bandwidth Measurement	38
4.4.1 Test Setup.....	38
4.4.2 Test Instruments.....	38
4.4.3 Test Procedure	38
4.4.4 Deviation from Test Standard	38
4.4.5 EUT Operating Condition.....	38
4.4.6 Test Result	39
4.5 Peak Power Spectral Density Measurement	41
4.5.1 Limits of Peak Power Spectral Density Measurement.....	41
4.5.2 Test Setup.....	41
4.5.3 Test Instruments.....	41
4.5.4 Test Procedure	41

4.5.5	Deviation from Test Standard	41
4.5.6	EUT Operating Condition.....	41
4.5.7	Test Results.....	42
4.6	Frequency Stability Measurement.....	45
4.6.1	Limits of Frequency Stability Measurement	45
4.6.2	Test Setup	45
4.6.3	Test Instruments	45
4.6.4	Test Procedure	45
4.6.5	Deviation from Test Standard	45
4.6.6	EUT Operating Condition.....	45
4.6.7	Test Results.....	46
4.7	6dB Bandwidth Measurement.....	47
4.7.1	Limits of 6dB Bandwidth Measurement	47
4.7.2	Test Setup	47
4.7.3	Test Instruments	47
4.7.4	Test Procedure	47
4.7.5	Deviation from Test Standard	47
4.7.6	EUT Operating Condition.....	47
4.7.7	Test Results.....	48
5	Pictures of Test Arrangements.....	50
	Annex A - Radiated Out of Band Emission (OOBE) Measurement (For U-NII-3 band)	51
	Appendix – Information on the Testing Laboratories.....	54

Report Issue History Record

Issue No.	Description	Date Issued
RF160321D09-1	Original release.	Apr. 1, 2016
RF160321D09A-1	Addition of model name: F9K1119V2.	May 30, 2016
RF160321D09B	Upgraded the standard to section 15.407 under new rule (16-24) for U-NII-3 band.	Jul. 28, 2016

Release Control Record

Issue No.	Description	Date Issued
RF160321D09B	Original release.	Jul. 28, 2016

1 Certificate of Conformity

Product: AC1900 DB Wi-Fi Dual-Band AC+ Gigabit Router,
AC1600 DB Wi-Fi Dual-Band AC+ Gigabit Router

Brand: Belkin

Test Model: F9K1124V1

Series Model: F9K1119V2

Sample Status: Engineering sample

Applicant: Belkin International, Inc.

Test Date: Jun. 28 ~ Jul. 4, 2016

Standard: 47 CFR FCC Part 15, Subpart E (Section 15.407)
ANSI C63.10: 2013

The above equipment has been tested by **Bureau Veritas Consumer Products Services (H.K.) Ltd., Taoyuan Branch**, and found compliance with the requirement of the above standards. The test record, data evaluation & Equipment Under Test (EUT) configurations represented herein are true and accurate accounts of the measurements of the sample's EMC characteristics under the conditions specified in this report.

Prepared by : Celia Chen , **Date:** Jul. 28, 2016
(Celia Chen / Supervisor)

Approved by : Rex Lai , **Date:** Jul. 28, 2016
(Rex Lai / Assistant Manager)

2 Summary of Test Results

47 CFR FCC Part 15, Subpart E (SECTION 15.407)			
FCC Clause	Test Item	Result	Remarks
15.407(b)(6)	AC Power Conducted Emissions	PASS	Meet the requirement of limit. Minimum passing margin is -6.80dB at 0.15000MHz.
15.407(b) (1/2/3/4(i/ii)/6)	Radiated Emissions & Band Edge Measurement*	PASS	Meet the requirement of limit. Minimum passing margin is -1.1dB at 5649.04MHz.
15.407(a)(1/2/3)	Max Average Transmit Power	PASS	Meet the requirement of limit.
15.407(a)(1/2/3)	Peak Power Spectral Density	PASS	Meet the requirement of limit.
15.407(e)	6dB bandwidth	PASS	Meet the requirement of limit. (U-NII-3 Band only)
15.407(g)	Frequency Stability	PASS	Meet the requirement of limit.
15.203	Antenna Requirement	PASS	Antenna connector is U.FL not a standard connector.

*For U-NII-3 band compliance with rule part 15.407(b)(4)(i), the OOB test plots were recorded in Annex A.

2.1 Measurement Uncertainty

Where relevant, the following measurement uncertainty levels have been estimated for tests performed on the EUT as specified in CISPR 16-4-2:

Measurement	Frequency	Expanded Uncertainty (k=2) (±)
Conducted Emissions at mains ports	150kHz ~ 30MHz	2.78 dB
Radiated Emissions up to 1 GHz	30MHz ~ 1000MHz	4.00 dB
Radiated Emissions above 1 GHz	1GHz ~ 40GHz	3.36 dB

2.2 Modification Record

There were no modifications required for compliance.

3 General Information

3.1 General Description of EUT

Product	AC1900 DB Wi-Fi Dual-Band AC+ Gigabit Router, AC1600 DB Wi-Fi Dual-Band AC+ Gigabit Router
Brand	Belkin
Test Model	F9K1124V1
Series Model	F9K1119V2
Model Difference	Refer to table as below
Status of EUT	Engineering sample
Power Supply Rating	12Vdc from Adapter
Modulation Type	64QAM, 16QAM, QPSK, BPSK 256QAM for OFDM in 11ac mode only.
Modulation Technology	OFDM
Transfer Rate	802.11a: 54/48/36/24/18/12/9/6Mbps 802.11n: up to 600Mbps 802.11ac: up to 1300Mbps
Operating Frequency	5745 ~ 5825MHz
Number of Channel	5745 ~ 5825MHz 5 for 802.11a, 802.11n (HT20) 2 for 802.11n (HT40) 1 for 802.11ac (VHT80)
Output Power	5745 ~ 5825MHz 468.241mW
Antenna Type	Refer to table as below
Antenna Connector	Refer to table as below
Accessory Device	Adapter
Data Cable Supplied	N/A

Model	F9K1124V1	F9K1119V2
Model Difference	For Model: F9K1119V2 only used software to control and disable antenna 3 (chain 2) of 2.4G Stream, the others to RF output power, RF parameter and hardware as same as Model: F9K1124V1.	
Driver Version	V1.04.03	V2.02.01
Product SW Version	V1.04.03	V2.02.01
Product HW Version	V1.0	V1.0
Radio SW Version	V1.04.03	V2.02.01
Radio HW Version	V1.0	V1.0

Note:

1. This report is a supplementary report of the original one (BV CPS report no.: RF160321D09-1 & RF160321D09A-1). The difference compared with original report is upgrading the standard to section 15.407 under new rule (16-24) for U-NII-3 band; therefore the EUT is re-tested in this report.
2. This report is prepared for FCC class II permissive change.
3. The EUT incorporates a MIMO function. Physically, the EUT provides three completed transmitters and four receivers.

Modulation Mode	TX FUNCTION
802.11a	3TX
802.11n (20MHz)	3TX
802.11n (40MHz)	3TX
802.11ac (20MHz)	3TX
802.11ac (40MHz)	3TX
802.11ac (80MHz)	3TX

* The modulation and bandwidth are similar for 802.11n mode for 20MHz / 40MHz and 802.11ac mode for 20MHz / 40MHz, therefore investigated worst case to representative mode in test report. (Final test mode refer section 3.2.1)

4. The following antennas were applied to the EUT:

Antenna	Brand	Model	Type	Connector	Gain (dBi)	
					2.4GHz	5.0GHz
TX & RX						
1	Airgain	N2420DG	Printed	U.FL	2.71	3.05
2	Airgain	N2420DGCS	Printed	U.FL	2.1	2.4
3	Airgain	N2420DG	Printed	U.FL	2.71	3.05
RX						
4	Airgain	N5X20SD	Printed	U.FL	-	3.48

5. The EUT was power supplied from the following power adapters:

Item	Brand	Model No.	Design No.	Plug Type	Rating
Adapter 1	Belkin	MU24-Y120200-A1	MU24-Y1120-AS1S	US	AC I/P: 100-240V, 50/60Hz, 0.7A DC O/P: 12V, 2A Non-shielded DC (1.5m)
	Belkin	MU24-Y120200-C5	MU24-Y1120-KS1S	EU	
	Belkin	MU24-Y120200-A3	MU24-Y1120-ES1S	AU	
	Belkin	MU24-Y120200-B2	MU24-Y1120-IS1S	UK	
Four adapters are identical with each other except for their plug type difference					
Adapter 2	Belkin	LW0NCA-US1220		US	AC I/P: 100-240V, 50/60Hz, 0.6A DC O/P: 12V, 2A Non-shielded DC (1.5m)
	Belkin	LW0NCA-EU1220		EU	
	Belkin	LW0NCA-UK1220		UK	
Three adapters are identical with each other except for their plug type difference					

Select the previous worse case (**Adapter 1**) for final test, therefore, only its test data was recorded in this report.

6. The EUT has several models with difference as follows:

Model	F9K1124V1	F9K1119V2
Model Difference	For Model: F9K1119V2 only used software to control and disable antenna 3 (chain 2) of 2.4G Stream, the others to RF output power, RF parameter and hardware as same as Model: F9K1124V1.	
Product Name	AC1900 DB Wi-Fi Dual-Band AC+ Gigabit Router	AC1600 DB Wi-Fi Dual-Band AC+ Gigabit Router
2.4G Stream	3TX&3RX	2TX&2RX
2.4G Phy Rate (Mbit/s)	600	300
5G Stream	3TX&4RX	3TX&4RX
5G Phy Rate (Mbit/s)	1300	1300
5GHz for 11a/c; 11 n	11 a/c and 11 n	11 a/c and 11 n
Driver Version	V1.04.03	V2.02.01
Product SW Version	V1.04.03	V2.02.01
Product HW Version	V1.0	V1.0
Radio SW Version	V1.04.03	V2.02.01
Radio HW Version	V1.0	V1.0
Outer Appearance		
I/O Port		
PCB-front		
PCB-rear		

7. The above EUT information is declared by manufacturer and for more detailed features description, please refer to the manufacturer's specifications or user's manual.

3.2 Description of Test Modes

FOR 5745 ~ 5825MHz:

5 channels are provided for 802.11a, 802.11n (20MHz), 802.11ac (20MHz):

Channel	Frequency	Channel	Frequency
149	5745MHz	161	5805MHz
153	5765MHz	165	5825MHz
157	5785MHz		

2 channels are provided for 802.11n (40MHz), 802.11ac (40MHz):

Channel	Frequency	Channel	Frequency
151	5755MHz	159	5795MHz

1 channel is provided for 802.11ac (80MHz):

Channel	Frequency
155	5775MHz

3.2.1 Test Mode Applicability and Tested Channel Detail

EUT CONFIGURE MODE	APPLICABLE TO				DESCRIPTION
	RE \geq 1G	RE<1G	PLC	APCM	
-	√	√	√	√	Model: F9K1124V1 with Adatper 1

Where **RE \geq 1G**: Radiated Emission above 1GHz **RE<1G**: Radiated Emission below 1GHz
PLC: Power Line Conducted Emission **APCM**: Antenna Port Conducted Measurement

Radiated Emission Test (Above 1GHz):

- Pre-Scan has been conducted to determine the worst-case mode from all possible combinations between available modulations, data rates and antenna ports (if EUT with antenna diversity architecture).
- Following channel(s) was (were) selected for the final test as listed below.

EUT CONFIGURE MODE	MODE	FREQ. BAND (MHz)	AVAILABLE CHANNEL	TESTED CHANNEL	MODULATION TECHNOLOGY	MODULATION TYPE	DATA RATE (Mbps)
-	802.11a	5745-5825	149 to 165	149, 157, 165	OFDM	BPSK	6.0
-	802.11n (20MHz)		149 to 165	149, 157, 165	OFDM	BPSK	6.5
-	802.11n (40MHz)		151 to 159	151, 159	OFDM	BPSK	13.5
-	802.11ac (80MHz)		155	155	OFDM	BPSK	29.3

Radiated Emission Test (Below 1GHz):

- Pre-Scan has been conducted to determine the worst-case mode from all possible combinations between available modulations, data rates and antenna ports (if EUT with antenna diversity architecture).
- Following channel(s) was (were) selected for the final test as listed below.

EUT CONFIGURE MODE	MODE	FREQ. BAND (MHz)	AVAILABLE CHANNEL	TESTED CHANNEL	MODULATION TECHNOLOGY	MODULATION TYPE	DATA RATE (Mbps)
-	802.11n (40MHz)	5745-5825	151 to 159	159	OFDM	BPSK	13.5

Power Line Conducted Emission Test:

- Pre-Scan has been conducted to determine the worst-case mode from all possible combinations between available modulations, data rates and antenna ports (if EUT with antenna diversity architecture).
- Following channel(s) was (were) selected for the final test as listed below.

EUT CONFIGURE MODE	MODE	FREQ. BAND (MHz)	AVAILABLE CHANNEL	TESTED CHANNEL	MODULATION TECHNOLOGY	MODULATION TYPE	DATA RATE (Mbps)
-	802.11n (40MHz)	5745-5825	151 to 159	159	OFDM	BPSK	13.5

Antenna Port Conducted Measurement:

- This item includes all test value of each mode, but only includes spectrum plot of worst value of each mode.
- Pre-Scan has been conducted to determine the worst-case mode from all possible combinations between available modulations, data rates and antenna ports (if EUT with antenna diversity architecture).
- Following channel(s) was (were) selected for the final test as listed below.

EUT CONFIGURE MODE	MODE	FREQ. BAND (MHz)	AVAILABLE CHANNEL	TESTED CHANNEL	MODULATION TECHNOLOGY	MODULATION TYPE	DATA RATE (Mbps)
-	802.11a	5745-5825	149 to 165	149, 157, 165	OFDM	BPSK	6.0
-	802.11n (20MHz)		149 to 165	149, 157, 165	OFDM	BPSK	6.5
-	802.11n (40MHz)		151 to 159	151, 159	OFDM	BPSK	13.5
-	802.11ac (80MHz)		155	155	OFDM	BPSK	29.3

Test Condition:

APPLICABLE TO	ENVIRONMENTAL CONDITIONS	INPUT POWER	TESTED BY
RE \geq 1G	23deg. C, 63%RH	120Vac, 60Hz	Ian Chang
RE $<$ 1G	22deg. C, 67%RH	120Vac, 60Hz	Aaron You
PLC	20deg. C, 81%RH	120Vac, 60Hz	Paul Chen
APCM	25deg. C, 60%RH	120Vac, 60Hz	Saxon Lee

3.3 Duty Cycle of Test Signal

Duty cycle of test signal is < 98 %, duty factor is required

802.11a: Duty cycle = $1.289/1.42 = 0.908$, Duty factor = $10 * \log(1/0.908) = 0.42$

802.11n (20MHz): Duty cycle = $1.231/1.318 = 0.934$, Duty factor = $10 * \log(1/0.934) = 0.30$

802.11n (40MHz): Duty cycle = $0.586/0.688 = 0.852$, Duty factor = $10 * \log(1/0.852) = 0.70$

802.11ac (80MHz): Duty cycle = $0.279/0.372 = 0.75$, Duty factor = $10 * \log(1/0.75) = 1.25$

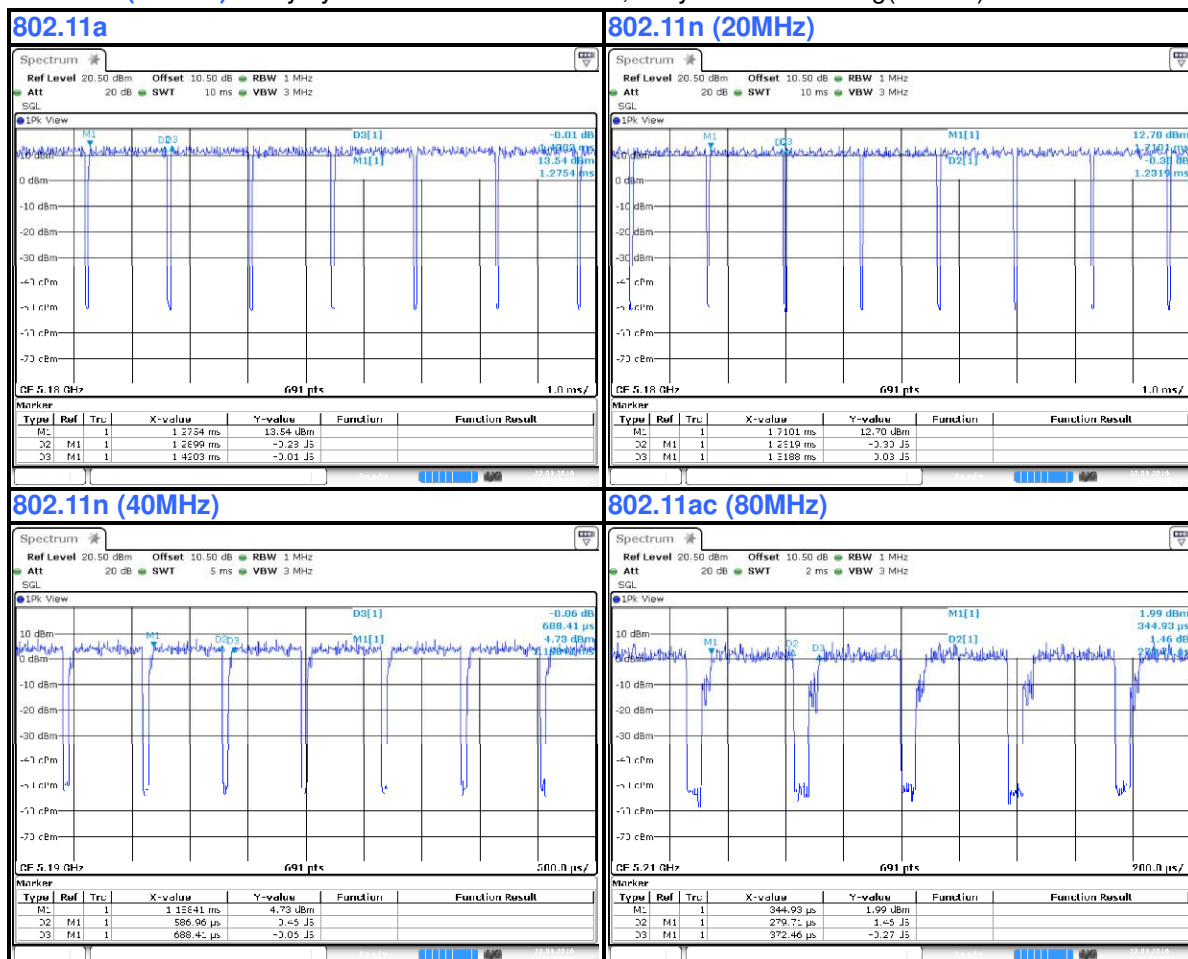

3.4 Description of Support Units

The EUT has been tested as an independent unit together with other necessary accessories or support units. The following support units or accessories were used to form a representative test configuration during the tests.

ID	Product	Brand	Model No.	Serial No.	FCC ID	Remarks
A.	USB 3.0 Hard Disk	WD	WDBACY5000ABL-PESN	WXD1E91JMPR4	FCC DoC Approved	Provided by Lab
B.	LAN Load	NA	NA	NA	NA	Provided by Lab
C.	Notebook PC	DELL	E6530	9331GV1	FCC DoC Approved	Provided by Lab
D.	Notebook PC	DELL	PP27L	8SNZ12S	FCC DoC Approved	Provided by Lab
E.	Notebook PC	DELL	E5410	BW33YM1	FCC DoC Approved	Provided by Lab
F.	Notebook PC	Lenovo	L440	R90HE6YK	FCC DoC Approved	Provided by Lab

Note:

1. All power cords of the above support units are non-shielded (1.8m).
2. Items C~F acted as communication partners to transfer data.

ID	Descriptions	Qty.	Length (m)	Shielding (Yes/No)	Cores (Qty.)	Remarks
1.	USB cable	1	0.5	Y	0	Provided by Lab
2.	LAN cable	3	1.8	N	0	Provided by Lab
3.	DC cable	1	1.5	N	0	Supplied by client
4.	LAN cable	2	10	N	0	Provided by Lab

Note: The core(s) is(are) originally attached to the cable(s).

3.4.1 Configuration of System under Test

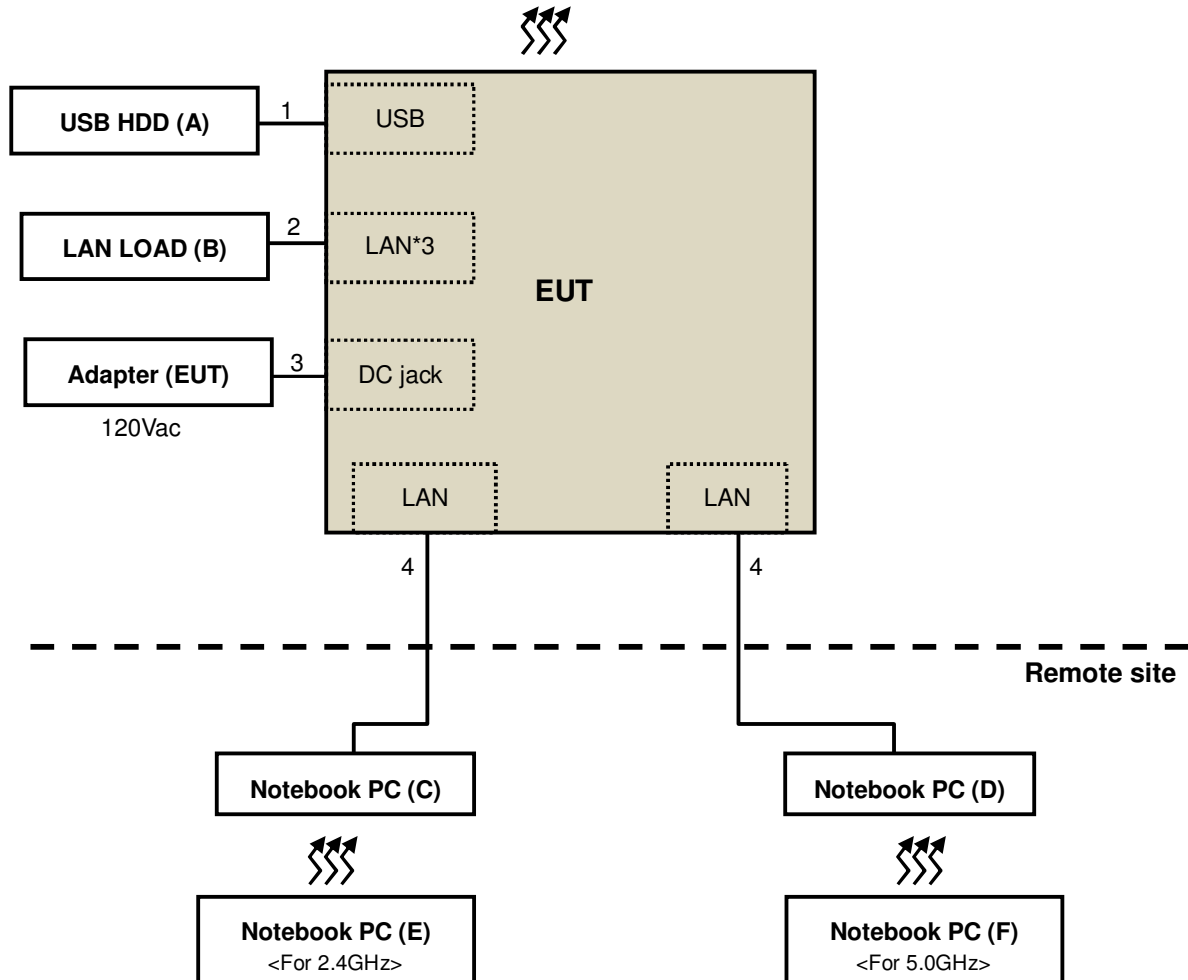

3.5 General Description of Applied Standard

The EUT is a RF Product. According to the specifications of the manufacturer, it must comply with the requirements of the following standards:

FCC Part 15, Subpart E (15.407)
KDB 789033 D02 General UNII Test Procedure New Rules v01r03
KDB 662911 D01 Multiple Transmitter Output v02r01
ANSI C63.10-2013

All test items have been performed and recorded as per the above standards.

NOTE: The EUT has been verified to comply with the requirements of FCC Part 15, Subpart B, Class B (DoC). The test report has been issued separately.

4 Test Types and Results

4.1 Radiated Emission and Bandedge Measurement

4.1.1 Limits of Radiated Emission and Bandedge Measurement

Radiated emissions which fall in the restricted bands must comply with the radiated emission limits specified as below table.

Frequencies (MHz)	Field Strength (microvolts/meter)	Measurement Distance (meters)
0.009 ~ 0.490	2400/F(kHz)	300
0.490 ~ 1.705	24000/F(kHz)	30
1.705 ~ 30.0	30	30
30 ~ 88	100	3
88 ~ 216	150	3
216 ~ 960	200	3
Above 960	500	3

NOTE:

1. The lower limit shall apply at the transition frequencies.
2. Emission level (dBuV/m) = 20 log Emission level (uV/m).
3. For frequencies above 1000MHz, the field strength limits are based on average detector, however, the peak field strength of any emission shall not exceed the maximum permitted average limits, specified above by more than 20dB under any condition of modulation.

Limits of unwanted emission out of the restricted bands

Applicable To	Limit	
789033 D02 General UNII Test Procedure New Rules v01r03	FIELD STRENGTH at 3m	
	PK:74 (dBuV/m)	AV:54 (dBuV/m)
Applicable To	EIRP Limit	Equivalent Field Strength at 3m
15.407(b)(1)	PK:-27 (dBm/MHz)	PK:68.2(dBμV/m)
15.407(b)(2)		
15.407(b)(3)		
15.407(b)(4)(i)	PK:-27 (dBm/MHz) ^{*1} PK:10 (dBm/MHz) ^{*2} PK:15.6 (dBm/MHz) ^{*3} PK:27 (dBm/MHz) ^{*4}	PK: 68.2(dBμV/m) ^{*1} PK:105.2 (dBμV/m) ^{*2} PK: 110.8(dBμV/m) ^{*3} PK:122.2 (dBμV/m) ^{*4}
15.407(b)(4)(ii)	FIELD STRENGTH at 3m / § 15.247(d),	
	PK:74 (dBuV/m)	AV:54 (dBuV/m)
^{*1} beyond 75 MHz or more above of the band edge.		^{*2} below the band edge increasing linearly to 10 dBm/MHz at 25 MHz above.
^{*3} below the band edge increasing linearly to a level of 15.6 dBm/MHz at 5 MHz above.		^{*4} from 5 MHz above or below the band edge increasing linearly to a level of 27 dBm/MHz at the band edge.

NOTE:

The following formula is used to convert the equipment isotropic radiated power (eirp) to field strength:

$$E = \frac{1000000\sqrt{30P}}{3} \mu\text{V/m, where P is the eirp (Watts).}$$

4.1.2 Test Instruments

DESCRIPTION & MANUFACTURER	MODEL NO.	SERIAL NO.	CALIBRATED DATE	CALIBRATED UNTIL
HP Preamplifier	8447D	2432A03504	Feb. 26, 2016	Feb. 25, 2017
HP Preamplifier	8449B	3008A01201	Feb. 26, 2016	Feb. 25, 2017
MITEQ Preamplifier	AMF-6F-260400-33-8P	892164	Mar. 01, 2016	Feb. 28, 2017
Agilent TEST RECEIVER	N9038A	MY51210129	Feb. 02, 2016	Feb. 01, 2017
Schwarzbeck Antenna	VULB 9168	139	Jan. 04, 2016	Jan. 03, 2017
Schwarzbeck Antenna	VHBA 9123	480	May 29, 2015	May 28, 2017
Schwarzbeck Horn Antenna	BBHA-9170	212	Jan. 08, 2016	Jan. 07, 2017
Schwarzbeck Horn Antenna	BBHA 9120-D1	D130	Jan. 21, 2016	Jan. 20, 2017
ADT. Turn Table	TT100	0306	NA	NA
ADT. Tower	AT100	0306	NA	NA
Software	Radiated_V7.6.15.9.4	NA	NA	NA
SUHNER RF cable With 4dB PAD	SF104	CABLE-CH6	Aug. 15, 2015	Aug. 14, 2016
SUHNER RF cable With 3dB PAD	SF102	Cable-CH8-3.6m	Aug. 15, 2015	Aug. 14, 2016
KEYSIGHT MIMO Powermeasurement Test set	U2021XA	U2021XA-001	May 25, 2016	May 24, 2017
KEYSIGHT Spectrum Analyzer	N9030A	MY54490260	Jul. 14, 2015	Jul. 13, 2016
EMCO Horn Antenna	3115	00028257	Jan. 19, 2016	Jan. 18, 2017
Highpass filter Wainwright Instruments	WHK 3.1/18G-10SS	SN 8	NA	NA
ROHDE & SCHWARZ Spectrum Analyzer	FSV40	101042	Sep. 23, 2015	Sep. 22, 2016
Anritsu Power Sensor	MA2411B	0738404	Apr. 28, 2016	Apr. 27, 2017
Anritsu Power Meter	ML2495A	0842014	Apr. 28, 2016	Apr. 27, 2017

- NOTE:**
1. The calibration interval of the above test instruments is 12/24 months. And the calibrations are traceable to NML/ROC and NIST/USA.
 2. The horn antenna and HP preamplifier (model: 8449B) are used only for the measurement of emission frequency above 1GHz if tested.
 3. The test was performed in Chamber No. 6.
 4. The Industry Canada Reference No. IC 7450E-6.
 5. The FCC Site Registration No. is 447212.

4.1.3 Test Procedure

- a. The EUT was placed on the top of a rotating table 0.8 meters (for below 1GHz) / 1.5 meters (for above 1GHz) above the ground at 3 meter chamber room for test. The table was rotated 360 degrees to determine the position of the highest radiation.
- b. The EUT was set 3 meters away from the interference-receiving antenna, which was mounted on the top of a variable-height antenna tower.
- c. The height of antenna is varied from one meter to four meters above the ground to determine the maximum value of the field strength. Both horizontal and vertical polarizations of the antenna are set to make the measurement.
- d. For each suspected emission, the EUT was arranged to its worst case and then the antenna was tuned to heights from 1 meter to 4 meters and the rotatable table was turned from 0 degrees to 360 degrees to find the maximum reading.
- e. The test-receiver system was set to quasi-peak detect function and specified bandwidth with maximum hold mode when the test frequency is below 1 GHz.
- f. The test-receiver system was set to peak and average detect function and specified bandwidth with maximum hold mode when the test frequency is above 1 GHz. If the peak reading value also meets average limit, measurement with the average detector is unnecessary.

Note:

1. The resolution bandwidth and video bandwidth of test receiver/spectrum analyzer is 120kHz for Quasi-peak detection (QP) at frequency below 1GHz.
2. The resolution bandwidth of test receiver/spectrum analyzer is 1 MHz and the video bandwidth is 3 MHz for Peak detection (PK) at frequency above 1GHz.
3. The resolution bandwidth of test receiver/spectrum analyzer is 1MHz and the video bandwidth is 3MHz for RMS Average (Duty cycle < 98%) for Average detection (AV) at frequency above 1GHz, then the measurement results was added to a correction factor ($10 \log(1/\text{duty cycle})$).
4. All modes of operation were investigated and the worst-case emissions are reported.

4.1.4 Deviation from Test Standard

No deviation.

4.1.5 Test Setup

<Frequency Range below 1GHz>

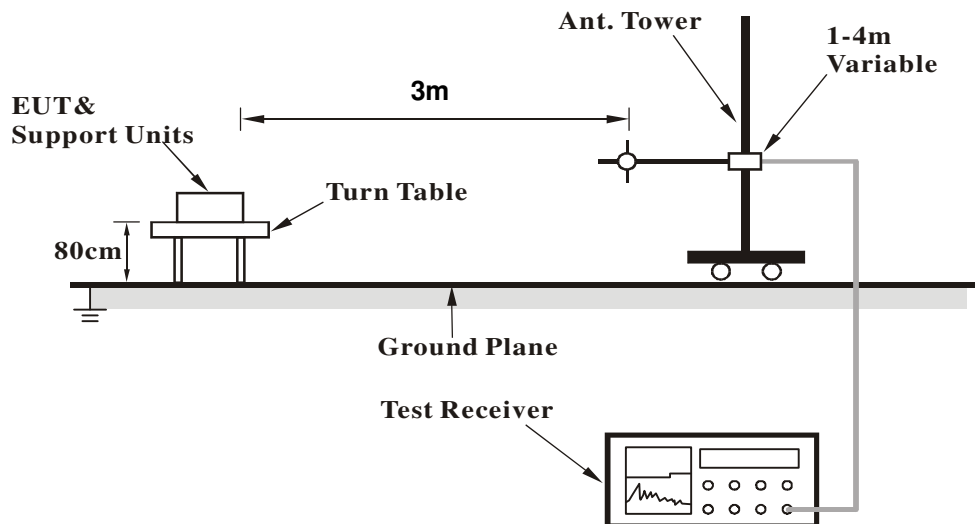

<Frequency Range above 1GHz>

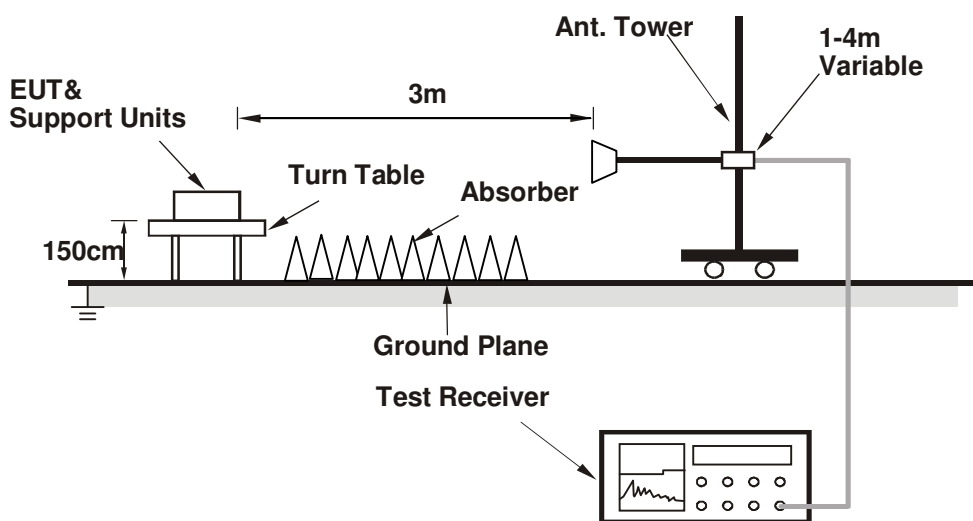

For the actual test configuration, please refer to the attached file (Test Setup Photo).

4.1.6 EUT Operating Condition

- Placed the EUT on the testing table.
- Prepared notebooks to act as communication partner and placed it outside of testing area.
- The communication partner connected with EUT via a RJ45 cable and ran a test program (provided by manufacturer) to enable EUT under transmission condition continuously at specific channel frequency.
- The communication partner sent data to EUT by command "PING".
- The necessary accessories enable the system in full functions.

4.1.7 Test Results

ABOVE 1GHz DATA

802.11a

CHANNEL	TX Channel 149	DETECTOR FUNCTION	Peak (PK)
FREQUENCY RANGE	1GHz ~ 40GHz		Average (AV)

ANTENNA POLARITY & TEST DISTANCE: HORIZONTAL AT 3 M

NO.	FREQ. (MHz)	EMISSION LEVEL (dBuV/m)	LIMIT (dBuV/m)	MARGIN (dB)	ANTENNA HEIGHT (m)	TABLE ANGLE (Degree)	RAW VALUE (dBuV)	CORRECTION FACTOR (dB/m)
1	#5654.22	68.9 PK	71.3	-2.4	1.86 H	279	60.2	8.6
2	*5745.00	112.9 PK			1.86 H	279	104.5	8.4
3	*5745.00	101.1 AV			1.86 H	279	92.6	8.4
4	#5927.00	58.7 PK	68.2	-9.5	1.86 H	279	50.2	8.5
5	11490.00	63.2 PK	74.0	-10.8	1.45 H	188	44.6	18.7
6	11490.00	52.0 AV	54.0	-2.0	1.45 H	188	33.4	18.7

ANTENNA POLARITY & TEST DISTANCE: VERTICAL AT 3 M

NO.	FREQ. (MHz)	EMISSION LEVEL (dBuV/m)	LIMIT (dBuV/m)	MARGIN (dB)	ANTENNA HEIGHT (m)	TABLE ANGLE (Degree)	RAW VALUE (dBuV)	CORRECTION FACTOR (dB/m)
1	#5647.97	60.2 PK	68.2	-8.0	3.04 V	267	51.5	8.7
2	*5745.00	115.2 PK			3.04 V	267	106.8	8.4
3	*5745.00	104.5 AV			3.04 V	267	96.1	8.4
4	#5930.55	60.0 PK	68.2	-8.2	3.04 V	267	51.4	8.5
5	11490.00	63.3 PK	74.0	-10.7	1.36 V	310	44.7	18.7
6	11490.00	52.5 AV	54.0	-1.5	1.36 V	310	33.8	18.7

REMARKS:

1. Emission Level(dBuV/m) = Raw Value(dBuV) + Correction Factor(dB/m)
2. Correction Factor(dB/m) = Antenna Factor(dB/m) + Cable Factor(dB) – Pre-Amplifier Factor(dB)
3. The other emission levels were very low against the limit.
4. Margin value = Emission Level – Limit value
5. " * ": Fundamental frequency.
6. " # ": The radiated frequency is out of the restricted band.

CHANNEL	TX Channel 157	DETECTOR FUNCTION	Peak (PK)
FREQUENCY RANGE	1GHz ~ 40GHz		Average (AV)

ANTENNA POLARITY & TEST DISTANCE: HORIZONTAL AT 3 M

NO.	FREQ. (MHz)	EMISSION LEVEL (dBuV/m)	LIMIT (dBuV/m)	MARGIN (dB)	ANTENNA HEIGHT (m)	TABLE ANGLE (Degree)	RAW VALUE (dBuV)	CORRECTION FACTOR (dB/m)
1	#5595.96	59.4 PK	68.2	-8.8	1.78 H	286	50.6	8.7
2	*5785.00	112.7 PK			1.78 H	286	104.4	8.3
3	*5785.00	102.2 AV			1.78 H	286	93.9	8.3
4	#5968.24	60.1 PK	68.2	-8.2	1.78 H	286	51.4	8.7
5	11570.00	62.2 PK	74.0	-11.9	1.01 H	248	43.3	18.8
6	11570.00	52.1 AV	54.0	-1.9	1.01 H	248	33.3	18.8

ANTENNA POLARITY & TEST DISTANCE: VERTICAL AT 3 M

NO.	FREQ. (MHz)	EMISSION LEVEL (dBuV/m)	LIMIT (dBuV/m)	MARGIN (dB)	ANTENNA HEIGHT (m)	TABLE ANGLE (Degree)	RAW VALUE (dBuV)	CORRECTION FACTOR (dB/m)
1	#5642.57	59.1 PK	68.2	-9.1	3.51 V	290	50.5	8.7
2	*5785.00	114.3 PK			3.51 V	290	105.9	8.3
3	*5785.00	103.0 AV			3.51 V	290	94.7	8.3
4	#5945.47	59.3 PK	68.2	-8.9	3.51 V	290	50.7	8.6
5	11570.00	62.8 PK	74.0	-11.2	1.22 V	318	44.0	18.8
6	11570.00	52.5 AV	54.0	-1.5	1.22 V	318	33.7	18.8

REMARKS:

1. Emission Level(dBuV/m) = Raw Value(dBuV) + Correction Factor(dB/m)
2. Correction Factor(dB/m) = Antenna Factor(dB/m) + Cable Factor(dB) – Pre-Amplifier Factor(dB)
3. The other emission levels were very low against the limit.
4. Margin value = Emission Level – Limit value
5. " * ": Fundamental frequency.
6. " # ": The radiated frequency is out of the restricted band.

CHANNEL	TX Channel 165	DETECTOR FUNCTION	Peak (PK)
FREQUENCY RANGE	1GHz ~ 40GHz		Average (AV)

ANTENNA POLARITY & TEST DISTANCE: HORIZONTAL AT 3 M

NO.	FREQ. (MHz)	EMISSION LEVEL (dBuV/m)	LIMIT (dBuV/m)	MARGIN (dB)	ANTENNA HEIGHT (m)	TABLE ANGLE (Degree)	RAW VALUE (dBuV)	CORRECTION FACTOR (dB/m)
1	#5635.60	58.5 PK	68.2	-9.7	1.69 H	288	49.8	8.7
2	*5825.00	113.6 PK			1.69 H	288	105.3	8.3
3	*5825.00	103.0 AV			1.69 H	288	94.6	8.3
4	#5964.07	60.5 PK	68.2	-7.7	1.69 H	288	51.8	8.7
5	11650.00	62.5 PK	74.0	-11.6	2.10 H	324	43.9	18.6
6	11650.00	51.8 AV	54.0	-2.2	2.10 H	324	33.3	18.6

ANTENNA POLARITY & TEST DISTANCE: VERTICAL AT 3 M

NO.	FREQ. (MHz)	EMISSION LEVEL (dBuV/m)	LIMIT (dBuV/m)	MARGIN (dB)	ANTENNA HEIGHT (m)	TABLE ANGLE (Degree)	RAW VALUE (dBuV)	CORRECTION FACTOR (dB/m)
1	#5642.60	58.6 PK	68.2	-9.6	2.45 V	252	50.0	8.7
2	*5825.00	114.1 PK			2.45 V	252	105.8	8.3
3	*5825.00	103.9 AV			2.45 V	252	95.6	8.3
4	#5946.96	59.7 PK	68.2	-8.5	2.45 V	252	51.1	8.6
5	11650.00	62.8 PK	74.0	-11.2	3.65 V	3	44.2	18.6
6	11650.00	52.4 AV	54.0	-1.6	3.65 V	3	33.8	18.6

REMARKS:

1. Emission Level(dBuV/m) = Raw Value(dBuV) + Correction Factor(dB/m)
2. Correction Factor(dB/m) = Antenna Factor(dB/m) + Cable Factor(dB) – Pre-Amplifier Factor(dB)
3. The other emission levels were very low against the limit.
4. Margin value = Emission Level – Limit value
5. " * ": Fundamental frequency.
6. " # ": The radiated frequency is out of the restricted band.

802.11n (20MHz)

CHANNEL	TX Channel 149	DETECTOR FUNCTION	Peak (PK)
FREQUENCY RANGE	1GHz ~ 40GHz		Average (AV)

ANTENNA POLARITY & TEST DISTANCE: HORIZONTAL AT 3 M

NO.	FREQ. (MHz)	EMISSION LEVEL (dBuV/m)	LIMIT (dBuV/m)	MARGIN (dB)	ANTENNA HEIGHT (m)	TABLE ANGLE (Degree)	RAW VALUE (dBuV)	CORRECTION FACTOR (dB/m)
1	#5645.66	65.2 PK	68.2	-3.0	1.47 H	23	56.6	8.7
2	*5745.00	113.3 PK			1.47 H	23	104.9	8.4
3	*5745.00	102.8 PK			1.47 H	23	94.4	8.4
4	#5954.88	59.3 PK	68.2	-8.9	1.47 H	23	50.7	8.6
5	11490.00	61.8 PK	74.0	-12.2	2.95 H	84	43.2	18.7
6	11490.00	51.2 AV	54.0	-2.8	2.95 H	84	32.5	18.7

ANTENNA POLARITY & TEST DISTANCE: VERTICAL AT 3 M

NO.	FREQ. (MHz)	EMISSION LEVEL (dBuV/m)	LIMIT (dBuV/m)	MARGIN (dB)	ANTENNA HEIGHT (m)	TABLE ANGLE (Degree)	RAW VALUE (dBuV)	CORRECTION FACTOR (dB/m)
1	#5646.46	66.4 PK	68.2	-1.8	2.74 V	0	57.7	8.7
2	*5745.00	114.1 PK			2.74 V	0	105.7	8.4
3	*5745.00	103.9 AV			2.74 V	0	95.5	8.4
4	#5941.97	59.3 PK	68.2	-8.9	2.74 V	0	50.7	8.6
5	11490.00	63.2 PK	74.0	-10.8	3.83 V	278	44.5	18.7
6	11490.00	51.9 AV	54.0	-2.1	3.83 V	278	33.3	18.7

REMARKS:

1. Emission Level(dBuV/m) = Raw Value(dBuV) + Correction Factor(dB/m)
2. Correction Factor(dB/m) = Antenna Factor(dB/m) + Cable Factor(dB) – Pre-Amplifier Factor(dB)
3. The other emission levels were very low against the limit.
4. Margin value = Emission Level – Limit value
5. " * ": Fundamental frequency.
6. " # ": The radiated frequency is out of the restricted band.

CHANNEL	TX Channel 157	DETECTOR FUNCTION	Peak (PK)
FREQUENCY RANGE	1GHz ~ 40GHz		Average (AV)

ANTENNA POLARITY & TEST DISTANCE: HORIZONTAL AT 3 M

NO.	FREQ. (MHz)	EMISSION LEVEL (dBuV/m)	LIMIT (dBuV/m)	MARGIN (dB)	ANTENNA HEIGHT (m)	TABLE ANGLE (Degree)	RAW VALUE (dBuV)	CORRECTION FACTOR (dB/m)
1	#5643.84	58.6 PK	68.2	-9.6	1.93 H	218	50.0	8.7
2	*5785.00	113.8 PK			1.93 H	218	105.5	8.3
3	*5785.00	104.2 AV			1.93 H	218	95.9	8.3
4	#5967.39	59.9 PK	68.2	-8.3	1.93 H	218	51.2	8.7
5	11570.00	62.1 PK	74.0	-11.9	2.09 H	115	43.3	18.8
6	11570.00	51.3 AV	54.0	-2.7	2.09 H	115	32.5	18.8

ANTENNA POLARITY & TEST DISTANCE: VERTICAL AT 3 M

NO.	FREQ. (MHz)	EMISSION LEVEL (dBuV/m)	LIMIT (dBuV/m)	MARGIN (dB)	ANTENNA HEIGHT (m)	TABLE ANGLE (Degree)	RAW VALUE (dBuV)	CORRECTION FACTOR (dB/m)
1	#5649.01	58.6 PK	68.2	-9.6	2.73 V	239	49.9	8.6
2	*5785.00	114.4 PK			2.73 V	239	106.0	8.3
3	*5785.00	104.5 AV			2.73 V	239	96.2	8.3
4	#5945.47	59.3 PK	68.2	-8.9	2.73 V	239	50.7	8.6
5	11570.00	62.4 PK	74.0	-11.6	2.41 V	94	43.6	18.8
6	11570.00	52.3 AV	54.0	-1.7	2.41 V	94	33.5	18.8

REMARKS:

1. Emission Level(dBuV/m) = Raw Value(dBuV) + Correction Factor(dB/m)
2. Correction Factor(dB/m) = Antenna Factor(dB/m) + Cable Factor(dB) – Pre-Amplifier Factor(dB)
3. The other emission levels were very low against the limit.
4. Margin value = Emission Level – Limit value
5. " * ": Fundamental frequency.
6. " # ": The radiated frequency is out of the restricted band.

CHANNEL	TX Channel 165	DETECTOR FUNCTION	Peak (PK)
FREQUENCY RANGE	1GHz ~ 40GHz		Average (AV)

ANTENNA POLARITY & TEST DISTANCE: HORIZONTAL AT 3 M

NO.	FREQ. (MHz)	EMISSION LEVEL (dBuV/m)	LIMIT (dBuV/m)	MARGIN (dB)	ANTENNA HEIGHT (m)	TABLE ANGLE (Degree)	RAW VALUE (dBuV)	CORRECTION FACTOR (dB/m)
1	#5634.74	58.1 PK	68.2	-10.1	1.82 H	41	49.4	8.7
2	*5825.00	114.4 PK			1.82 H	41	106.1	8.3
3	*5825.00	104.2 AV			1.82 H	41	95.9	8.3
4	#5998.58	60.8 PK	68.2	-7.4	1.82 H	41	52.0	8.8
5	11650.00	62.0 PK	74.0	-12.0	1.75 H	36	43.4	18.6
6	11650.00	51.5 AV	54.0	-2.6	1.75 H	36	32.9	18.6

ANTENNA POLARITY & TEST DISTANCE: VERTICAL AT 3 M

NO.	FREQ. (MHz)	EMISSION LEVEL (dBuV/m)	LIMIT (dBuV/m)	MARGIN (dB)	ANTENNA HEIGHT (m)	TABLE ANGLE (Degree)	RAW VALUE (dBuV)	CORRECTION FACTOR (dB/m)
1	#5640.20	58.7 PK	68.2	-9.6	2.50 V	290	50.0	8.7
2	*5825.00	115.1 PK			2.50 V	290	106.7	8.3
3	*5825.00	105.1 AV			2.50 V	290	96.8	8.3
4	#5938.35	59.3 PK	68.2	-8.9	2.50 V	290	50.8	8.6
5	11650.00	62.7 PK	74.0	-11.3	1.98 V	241	44.2	18.6
6	11650.00	51.8 AV	54.0	-2.3	1.98 V	241	33.2	18.6

REMARKS:

1. Emission Level(dBuV/m) = Raw Value(dBuV) + Correction Factor(dB/m)
2. Correction Factor(dB/m) = Antenna Factor(dB/m) + Cable Factor(dB) – Pre-Amplifier Factor(dB)
3. The other emission levels were very low against the limit.
4. Margin value = Emission Level – Limit value
5. " * ": Fundamental frequency.
6. " # ": The radiated frequency is out of the restricted band.

802.11n (40MHz)

CHANNEL	TX Channel 151	DETECTOR FUNCTION	Peak (PK)
FREQUENCY RANGE	1GHz ~ 40GHz		Average (AV)

ANTENNA POLARITY & TEST DISTANCE: HORIZONTAL AT 3 M

NO.	FREQ. (MHz)	EMISSION LEVEL (dBuV/m)	LIMIT (dBuV/m)	MARGIN (dB)	ANTENNA HEIGHT (m)	TABLE ANGLE (Degree)	RAW VALUE (dBuV)	CORRECTION FACTOR (dB/m)
1	#5645.02	66.8 PK	68.2	-1.4	2.12 H	162	58.1	8.7
2	*5755.00	110.4 PK			2.12 H	162	102.0	8.4
3	*5755.00	100.1 AV			2.12 H	162	91.7	8.4
4	#5975.26	60.6 PK	68.2	-7.6	2.12 H	162	51.9	8.7
5	11510.00	60.2 PK	74.0	-13.8	1.63 H	114	41.6	18.6
6	11510.00	49.2 AV	54.0	-4.8	1.63 H	114	30.6	18.6

ANTENNA POLARITY & TEST DISTANCE: VERTICAL AT 3 M

NO.	FREQ. (MHz)	EMISSION LEVEL (dBuV/m)	LIMIT (dBuV/m)	MARGIN (dB)	ANTENNA HEIGHT (m)	TABLE ANGLE (Degree)	RAW VALUE (dBuV)	CORRECTION FACTOR (dB/m)
1	#5649.04	67.1 PK	68.2	-1.1	2.48 V	269	58.5	8.6
2	*5755.00	111.9 PK			2.48 V	269	103.5	8.4
3	*5755.00	102.3 AV			2.48 V	269	93.9	8.4
4	#5936.08	60.1 PK	68.2	-8.1	2.48 V	269	51.6	8.5
5	11510.00	61.2 PK	74.0	-12.8	1.87 V	182	42.6	18.6
6	11510.00	50.4 AV	54.0	-3.6	1.87 V	182	31.7	18.6

REMARKS:

1. Emission Level(dBuV/m) = Raw Value(dBuV) + Correction Factor(dB/m)
2. Correction Factor(dB/m) = Antenna Factor(dB/m) + Cable Factor(dB) – Pre-Amplifier Factor(dB)
3. The other emission levels were very low against the limit.
4. Margin value = Emission Level – Limit value
5. " * ": Fundamental frequency.
6. " # ": The radiated frequency is out of the restricted band.

CHANNEL	TX Channel 159	DETECTOR FUNCTION	Peak (PK)
FREQUENCY RANGE	1GHz ~ 40GHz		Average (AV)

ANTENNA POLARITY & TEST DISTANCE: HORIZONTAL AT 3 M

NO.	FREQ. (MHz)	EMISSION LEVEL (dBuV/m)	LIMIT (dBuV/m)	MARGIN (dB)	ANTENNA HEIGHT (m)	TABLE ANGLE (Degree)	RAW VALUE (dBuV)	CORRECTION FACTOR (dB/m)
1	#5640.77	65.3 PK	68.2	-2.9	1.64 H	22	56.7	8.7
2	*5795.00	111.0 PK			1.64 H	22	102.7	8.3
3	*5795.00	101.0 AV			1.64 H	22	92.7	8.3
4	#5923.36	66.3 PK	69.4	-3.1	1.64 H	22	57.8	8.5
5	11590.00	60.0 PK	74.0	-14.0	2.31 H	241	41.2	18.9
6	11590.00	49.4 AV	54.0	-4.6	2.31 H	241	30.6	18.9

ANTENNA POLARITY & TEST DISTANCE: VERTICAL AT 3 M

NO.	FREQ. (MHz)	EMISSION LEVEL (dBuV/m)	LIMIT (dBuV/m)	MARGIN (dB)	ANTENNA HEIGHT (m)	TABLE ANGLE (Degree)	RAW VALUE (dBuV)	CORRECTION FACTOR (dB/m)
1	#5644.96	64.0 PK	68.2	-4.2	2.59 V	254	55.4	8.7
2	*5795.00	112.1 PK			2.59 V	254	103.8	8.3
3	*5795.00	102.0 AV			2.59 V	254	93.7	8.3
4	#5930.32	67.0 PK	68.2	-1.2	2.59 V	254	58.5	8.5
5	11590.00	61.1 PK	74.0	-13.0	1.87 V	225	42.2	18.9
6	11590.00	50.5 AV	54.0	-3.5	1.87 V	225	31.6	18.9

REMARKS:

1. Emission Level(dBuV/m) = Raw Value(dBuV) + Correction Factor(dB/m)
2. Correction Factor(dB/m) = Antenna Factor(dB/m) + Cable Factor(dB) – Pre-Amplifier Factor(dB)
3. The other emission levels were very low against the limit.
4. Margin value = Emission Level – Limit value
5. " * ": Fundamental frequency.
6. " # ": The radiated frequency is out of the restricted band.

802.11ac (80MHz)

CHANNEL	TX Channel 155	DETECTOR FUNCTION	Peak (PK)
FREQUENCY RANGE	1GHz ~ 40GHz		Average (AV)

ANTENNA POLARITY & TEST DISTANCE: HORIZONTAL AT 3 M

NO.	FREQ. (MHz)	EMISSION LEVEL (dBuV/m)	LIMIT (dBuV/m)	MARGIN (dB)	ANTENNA HEIGHT (m)	TABLE ANGLE (Degree)	RAW VALUE (dBuV)	CORRECTION FACTOR (dB/m)
1	#5630.33	64.9 PK	68.2	-3.3	2.32 H	225	56.2	8.7
2	*5775.00	105.9 PK			2.32 H	225	97.5	8.4
3	*5775.00	95.8 AV			2.32 H	225	87.5	8.4
4	#5928.62	65.9 PK	68.2	-2.3	2.32 H	225	57.4	8.5
5	11550.00	58.3 PK	74.0	-15.7	1.78 H	241	39.6	18.7
6	11550.00	46.6 AV	54.0	-7.4	1.78 H	241	27.9	18.7

ANTENNA POLARITY & TEST DISTANCE: VERTICAL AT 3 M

NO.	FREQ. (MHz)	EMISSION LEVEL (dBuV/m)	LIMIT (dBuV/m)	MARGIN (dB)	ANTENNA HEIGHT (m)	TABLE ANGLE (Degree)	RAW VALUE (dBuV)	CORRECTION FACTOR (dB/m)
1	#5629.15	67.1 PK	68.2	-1.2	2.60 V	254	58.4	8.7
2	*5775.00	107.7 PK			2.60 V	254	99.3	8.4
3	*5775.00	98.3 AV			2.60 V	254	89.9	8.4
4	#5927.86	64.4 PK	68.2	-3.8	2.60 V	254	55.9	8.5
5	11550.00	58.9 PK	74.0	-15.1	2.36 V	169	40.2	18.7
6	11550.00	47.2 AV	54.0	-6.8	2.36 V	169	28.5	18.7

REMARKS:

1. Emission Level(dBuV/m) = Raw Value(dBuV) + Correction Factor(dB/m)
2. Correction Factor(dB/m) = Antenna Factor(dB/m) + Cable Factor(dB) – Pre-Amplifier Factor(dB)
3. The other emission levels were very low against the limit.
4. Margin value = Emission Level – Limit value
5. " * ": Fundamental frequency.
6. " # ": The radiated frequency is out of the restricted band.

BELOW 1GHz WORST-CASE DATA

802.11n (40MHz)

CHANNEL	TX Channel 159	DETECTOR FUNCTION	Quasi-Peak (QP)
FREQUENCY RANGE	30MHz ~ 1GHz		

ANTENNA POLARITY & TEST DISTANCE: HORIZONTAL AT 3 M

NO.	FREQ. (MHz)	EMISSION LEVEL (dBuV/m)	LIMIT (dBuV/m)	MARGIN (dB)	ANTENNA HEIGHT (m)	TABLE ANGLE (Degree)	RAW VALUE (dBuV)	CORRECTION FACTOR (dB/m)
1	30.44	32.0 QP	40.0	-8.0	4.00 H	91	43.50	-11.49
2	70.35	32.0 QP	40.0	-8.0	4.00 H	227	43.43	-11.40
3	98.14	33.4 QP	43.5	-10.1	4.00 H	252	47.86	-14.47
4	163.47	32.1 QP	43.5	-11.4	3.81 H	250	41.48	-9.35
5	223.61	32.9 QP	46.0	-13.1	2.94 H	79	44.71	-11.81
6	579.99	39.6 QP	46.0	-6.4	1.36 H	104	41.64	-2.05
7	901.88	37.4 QP	46.0	-8.6	1.00 H	81	34.04	3.34

ANTENNA POLARITY & TEST DISTANCE: VERTICAL AT 3 M

NO.	FREQ. (MHz)	EMISSION LEVEL (dBuV/m)	LIMIT (dBuV/m)	MARGIN (dB)	ANTENNA HEIGHT (m)	TABLE ANGLE (Degree)	RAW VALUE (dBuV)	CORRECTION FACTOR (dB/m)
1	35.26	38.7 QP	40.0	-1.3	1.33 V	131	49.76	-11.03
2	62.64	37.9 QP	40.0	-2.1	1.25 V	0	48.30	-10.39
3	125.01	36.7 QP	43.5	-6.9	1.00 V	125	48.13	-11.48
4	258.14	31.6 QP	46.0	-14.4	2.06 V	121	40.88	-9.25
5	386.72	31.0 QP	46.0	-15.0	2.43 V	111	36.80	-5.81
6	575.53	37.7 QP	46.0	-8.3	2.88 V	136	39.80	-2.10
7	966.68	36.6 QP	54.0	-17.5	3.17 V	116	31.54	5.01

REMARKS:

1. Emission Level(dBuV/m) = Raw Value(dBuV) + Correction Factor(dB/m)
2. Correction Factor(dB/m) = Antenna Factor(dB/m) + Cable Factor(dB) – Pre-Amplifier Factor(dB)
3. The other emission levels were very low against the limit.
4. Margin value = Emission Level – Limit value

4.2 Conducted Emission Measurement

4.2.1 Limits of Conducted Emission Measurement

Frequency (MHz)	Conducted Limit (dBUV)	
	Quasi-peak	Average
0.15 - 0.5	66 - 56	56 - 46
0.50 - 5.0	56	46
5.0 - 30.0	60	50

Note: 1. The lower limit shall apply at the transition frequencies.

2. The limit decreases in line with the logarithm of the frequency in the range of 0.15 to 0.50MHz.

4.2.2 Test Instruments

Description & Manufacturer	Model No.	Serial No.	Cal. Date	Cal. Due
ROHDE & SCHWARZ TEST RECEIVER	ESCS 30	100276	Apr. 01, 2015	Mar. 31, 2016
ROHDE & SCHWARZ Artificial Mains Network (for EUT)	ENV216	101197	Apr. 27, 2015	Apr. 26, 2016
LISN With Adapter (for EUT)	AD10	C10Ada-002	Apr. 27, 2015	Apr. 26, 2016
ROHDE & SCHWARZ Artificial Mains Network (for peripherals)	ESH3-Z5	100218	Nov. 25, 2015	Nov. 24, 2016
SCHWARZBECK Artificial Mains Network (For EUT)	NNLK8129	8129229	May 06, 2015	May 05, 2016
Software	Cond_V7.3.7	NA	NA	NA
RF cable (JYEBAO) With 10dB PAD	5D-FB	Cable-C10.01	Feb. 15, 2016	Feb. 14, 2017
SUHNER Terminator (For ROHDE & SCHWARZ LISN)	65BNC-5001	E1-011484	May 19, 2015	May 18, 2016
ROHDE & SCHWARZ Artificial Mains Network (For TV EUT)	ESH3-Z5	100220	Nov. 13, 2015	Nov. 12, 2016
LISN With Adapter (for TV EUT)	100220	N/A	Nov. 13, 2015	Nov. 12, 2016

Notes: 1. The calibration interval of the above test instruments is 12 months and the calibrations are traceable to NML/ROC and NIST/USA.

2. The test was performed in Shielded Room No. 10.

3. The VCCI Site Registration No. C-1852.

4.2.3 Test Procedure

- The EUT was placed 0.4 meters from the conducting wall of the shielded room with EUT being connected to the power mains through a line impedance stabilization network (LISN). Other support units were connected to the power mains through another LISN. The two LISNs provide 50 ohm/ 50uH of coupling impedance for the measuring instrument.
- Both lines of the power mains connected to the EUT were checked for maximum conducted interference.
- The frequency range from 150kHz to 30MHz was searched. Emission levels under (Limit - 20dB) was not recorded.

NOTE: All modes of operation were investigated and the worst-case emissions are reported.

4.2.4 Deviation from Test Standard

No deviation.

4.2.5 Test Setup

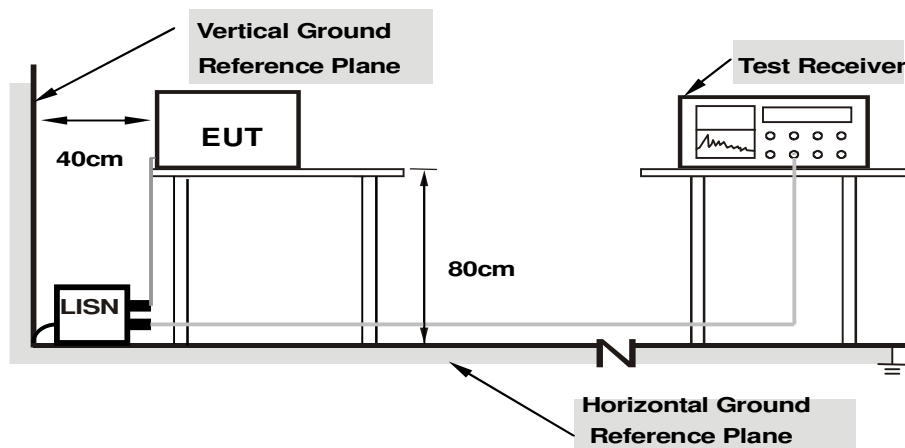

- Note:**
- Support units were connected to second LISN.
 - Both of LISNs (AMN) are 80 cm from EUT and at least 80 from other units and other metal planes

For the actual test configuration, please refer to the attached file (Test Setup Photo).

4.2.6 EUT Operating Condition

Same as 4.1.6.

4.2.7 Test Results

802.11n (40MHz): CH159

Phase	Line (L)	Detector Function	Quasi-Peak (QP) / Average (AV)
-------	----------	-------------------	--------------------------------

No	Frequency (MHz)	Correction Factor (dB)	Reading Value (dBuV)		Emission Level (dBuV)		Limit (dBuV)		Margin (dB)	
			Q.P.	AV.	Q.P.	AV.	Q.P.	AV.	Q.P.	AV.
1	0.15000	9.66	49.54	37.53	59.20	47.19	66.00	56.00	-6.80	-8.81
2	0.18125	9.65	43.22	32.28	52.87	41.93	64.43	54.43	-11.55	-12.49
3	0.23203	9.65	38.51	28.28	48.16	37.93	62.38	52.38	-14.21	-14.44
4	0.39336	9.68	32.94	28.04	42.62	37.72	57.99	47.99	-15.37	-10.27
5	1.90234	9.86	13.48	7.60	23.34	17.46	56.00	46.00	-32.66	-28.54
6	12.49219	10.16	29.59	24.56	39.75	34.72	60.00	50.00	-20.25	-15.28

Remarks:

1. Q.P. and AV. are abbreviations of quasi-peak and average individually.
2. The emission levels of other frequencies were very low against the limit.
3. Margin value = Emission level – Limit value
4. Correction factor = Insertion loss + Cable loss
5. Emission Level = Correction Factor + Reading Value

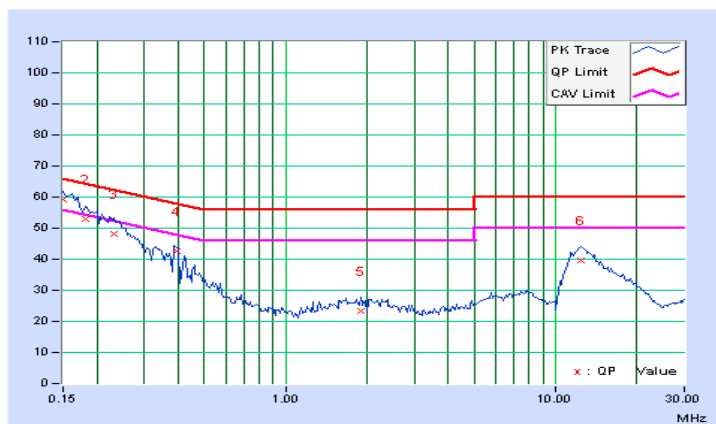

Phase	Neutral (N)	Detector Function	Quasi-Peak (QP) / Average (AV)
-------	-------------	-------------------	--------------------------------

No	Frequency (MHz)	Correction Factor (dB)	Reading Value (dBuV)		Emission Level (dBuV)		Limit (dBuV)		Margin (dB)	
			Q.P.	AV.	Q.P.	AV.	Q.P.	AV.	Q.P.	AV.
1	0.15000	9.69	49.13	38.72	58.82	48.41	66.00	56.00	-7.18	-7.59
2	0.20078	9.69	40.24	29.64	49.93	39.33	63.58	53.58	-13.65	-14.25
3	0.24766	9.70	36.62	26.03	46.32	35.73	61.84	51.84	-15.52	-16.11
4	0.39219	9.72	31.12	23.57	40.84	33.29	58.02	48.02	-17.18	-14.73
5	1.25391	9.82	16.83	9.95	26.65	19.77	56.00	46.00	-29.35	-26.23
6	12.60938	10.25	29.28	24.11	39.53	34.36	60.00	50.00	-20.47	-15.64

Remarks:

1. Q.P. and AV. are abbreviations of quasi-peak and average individually.
2. The emission levels of other frequencies were very low against the limit.
3. Margin value = Emission level – Limit value
4. Correction factor = Insertion loss + Cable loss
5. Emission Level = Correction Factor + Reading Value

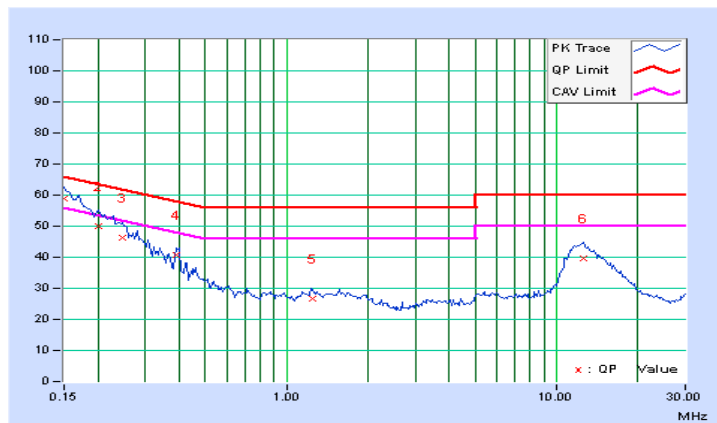

4.3 Transmit Power Measurement

4.3.1 Limits of Transmit Power Measurement

Operation Band	EUT Category		LIMIT
U-NII-1	---	Outdoor Access Point	1 Watt (30 dBm) (Max. e.i.r.p \leq 125mW(21 dBm) at any elevation angle above 30 degrees as measured from the horizon)
	---	Fixed point-to-point Access Point	1 Watt (30 dBm)
	---	Indoor Access Point	1 Watt (30 dBm)
	---	Mobile and Portable client device	250mW (24 dBm)
U-NII-2A	---		250mW (24 dBm) or 11 dBm+10 log B*
U-NII-2C	---		250mW (24 dBm) or 11 dBm+10 log B*
U-NII-3	√		1 Watt (30 dBm)

*B is the 26 dB emission bandwidth in megahertz

Per KDB 662911 Method of conducted output power measurement on IEEE 802.11 devices,

Array Gain = 0 dB (i.e., no array gain) for $N_{ANT} \leq 4$;

Array Gain = 0 dB (i.e., no array gain) for channel widths \geq 40 MHz for any N_{ANT} ;

Array Gain = $5 \log(N_{ANT}/N_{SS})$ dB or 3 dB, whichever is less for 20-MHz channel widths with $N_{ANT} \geq 5$.

For power measurements on all other devices: Array Gain = $10 \log(N_{ANT}/N_{SS})$ dB.

4.3.2 Test Setup

FOR POWER OUTPUT MEASUREMENT

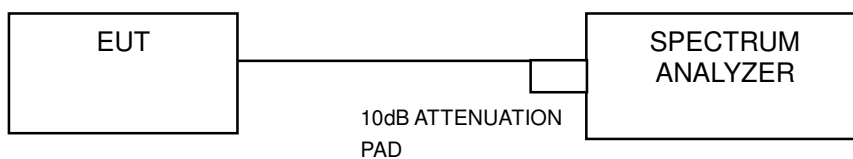

FOR 26dB BANDWIDTH

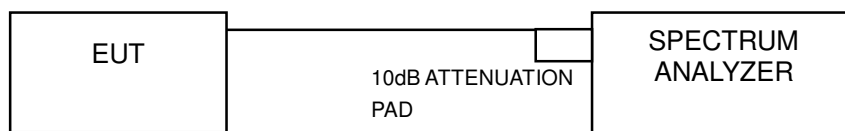

4.3.3 Test Instruments

Refer to section 4.1.2 to get information of above instrument.

4.3.4 Test Procedure

FOR AVERAGE POWER MEASUREMENT

For 802.11a, 802.11n (20MHz), 802.11n (40MHz)

Method PM is used to perform output power measurement, trigger and gating function of wide band power meter is enabled to measure max output power of TX on burst. Duty factor is not added to measured value.

For 802.11ac (80MHz)

- 1) Set span to encompass the entire 26 dB EBW (or, alternatively, the entire 99% occupied bandwidth) of the signal.
- 2) Set sweep trigger to "free run".
- 3) Set RBW = 1 MHz.
- 4) Set VBW \geq 3 MHz
- 5) Number of points in sweep \geq 2 Span / RBW.
- 6) Sweep time \leq (number of points in sweep) * T
- 7) Using emission bandwidth to determine the frequency span for integration the channel bandwidth.
- 8) Detector = RMS.
- 9) Trace mode = max hold.
- 10) Allow max hold to run for at least 60 seconds, or longer as needed to allow the trace to stabilize.

FOR 26dB BANDWIDTH

- 1) Set RBW = approximately 1% of the emission bandwidth.
- 2) Set the VBW $>$ RBW.
- 3) Detector = Peak.
- 4) Trace mode = max hold.
- 5) Measure the maximum width of the emission that is 26 dB down from the peak of the emission. Compare this with the RBW setting of the analyzer. Readjust RBW and repeat measurement as needed until the RBW/EBW ratio is approximately 1%.

4.3.5 Deviation from Test Standard

No deviation.

4.3.6 EUT Operating Condition

The software provided by client to enable the EUT under transmission condition continuously at lowest, middle and highest channel frequencies individually.

4.3.7 Test Result

POWER OUTPUT:
802.11a

CHAN.	CHAN. FREQ. (MHz)	MAXIMUM CONDUCTED POWER (dBm)			TOTAL POWER (mW)	TOTAL POWER (dBm)	POWER LIMIT (dBm)	PASS / FAIL
		CHAIN 0	CHAIN 1	CHAIN 2				
149	5745	21.05	21.00	20.93	377.123	25.76	30	PASS
157	5785	21.01	20.93	20.82	370.844	25.69	30	PASS
165	5825	21.06	21.02	20.96	378.856	25.78	30	PASS

802.11n (20MHz)

CHAN.	CHAN. FREQ. (MHz)	MAXIMUM CONDUCTED POWER (dBm)			TOTAL POWER (mW)	TOTAL POWER (dBm)	POWER LIMIT (dBm)	PASS / FAIL
		CHAIN 0	CHAIN 1	CHAIN 2				
149	5745	20.39	20.36	20.31	325.438	25.12	30	PASS
157	5785	21.84	21.77	21.74	452.35	26.55	30	PASS
165	5825	21.91	21.82	21.77	457.608	26.60	30	PASS

802.11n (40MHz)

CHAN.	CHAN. FREQ. (MHz)	MAXIMUM CONDUCTED POWER (dBm)			TOTAL POWER (mW)	TOTAL POWER (dBm)	POWER LIMIT (dBm)	PASS / FAIL
		CHAIN 0	CHAIN 1	CHAIN 2				
151	5755	19.46	19.35	19.22	257.967	24.12	30	PASS
159	5795	21.98	21.93	21.89	468.241	26.70	30	PASS

802.11ac (80MHz)

CHAN.	CHAN. FREQ. (MHz)	MAXIMUM CONDUCTED POWER (dBm)			TOTAL POWER (mW)	TOTAL POWER (dBm)	POWER LIMIT (dBm)	PASS / FAIL
		CHAIN 0	CHAIN 1	CHAIN 2				
155	5775	16.22	16.01	15.82	119.975	20.79	30	PASS

4.4 Occupied Bandwidth Measurement

4.4.1 Test Setup

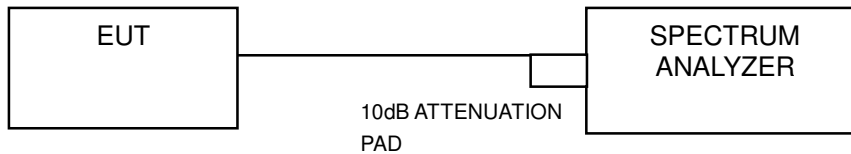

4.4.2 Test Instruments

Refer to section 4.1.2 to get information of above instrument.

4.4.3 Test Procedure

The transmitter output was connected to the spectrum analyzer through an attenuator. The bandwidth of the fundamental frequency was measured by spectrum analyzer with resolution bandwidth in the range of 1% to 5% of the anticipated emission bandwidth, and a video bandwidth at least 3x the resolution bandwidth and set the detector to SAMPLE. The width of a frequency band such that, below the lower and above the upper frequency limits, the mean powers emitted are each equal to a specified percentage 0.5 %of the total mean power of a given emission.

4.4.4 Deviation from Test Standard

No deviation.

4.4.5 EUT Operating Condition

Same as Item 4.3.6.

4.4.6 Test Result

802.11a

CHANNEL	CHANNEL FREQUENCY (MHz)	OCCUPIED BANDWIDTH (MHz)			PASS / FAIL
		CHAIN 0	CHAIN 1	CHAIN 2	
149	5745	28.08	28.10	27.80	PASS
157	5785	29.30	29.70	28.20	PASS
165	5825	30.90	31.00	30.90	PASS

802.11n (20MHz)

CHANNEL	CHANNEL FREQUENCY (MHz)	OCCUPIED BANDWIDTH (MHz)			PASS / FAIL
		CHAIN 0	CHAIN 1	CHAIN 2	
149	5745	23.13	25.50	25.30	PASS
157	5785	34.00	34.10	34.40	PASS
165	5825	40.20	40.50	40.60	PASS

802.11n (40MHz)

CHANNEL	CHANNEL FREQUENCY (MHz)	OCCUPIED BANDWIDTH (MHz)			PASS / FAIL
		CHAIN 0	CHAIN 1	CHAIN 2	
151	5755	37.53	41.16	40.83	PASS
159	5795	59.50	59.66	60.14	PASS

802.11ac (80MHz)

CHANNEL	CHANNEL FREQUENCY (MHz)	OCCUPIED BANDWIDTH (MHz)			PASS / FAIL
		CHAIN 0	CHAIN 1	CHAIN 2	
155	5775	76.28	76.44	76.44	PASS



SPECTRUM PLOT OF WORST VALUE

802.11a

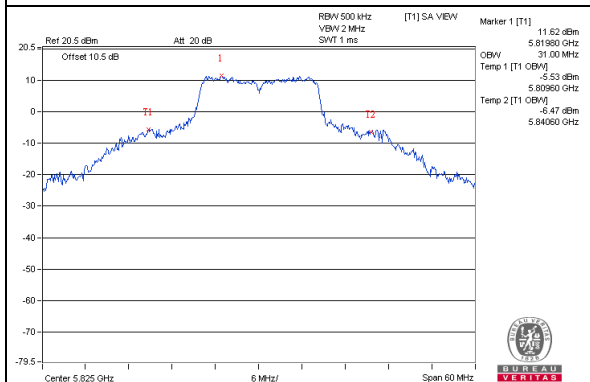

802.11n (20MHz)

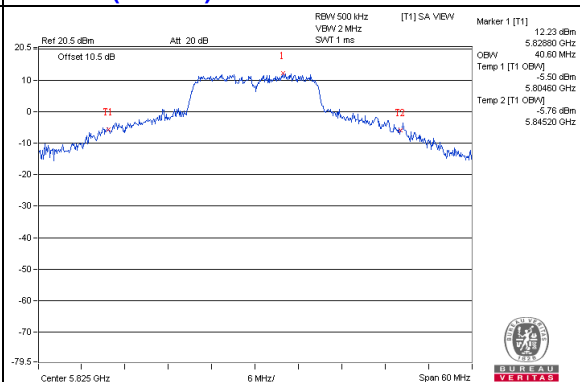

802.11n (40MHz)

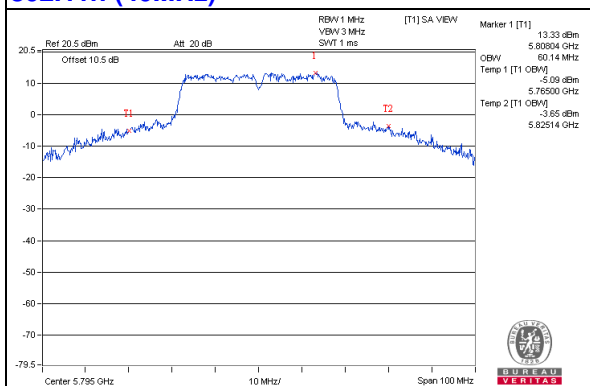

802.11ac (80MHz)

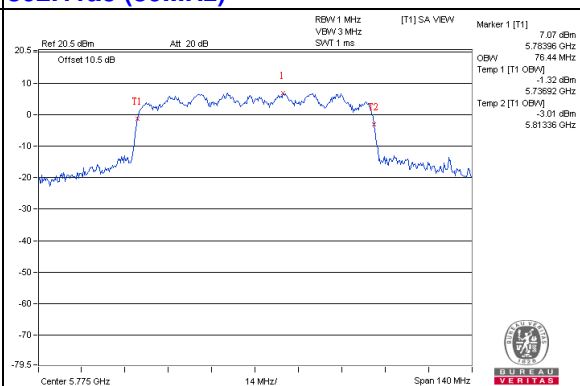

4.5 Peak Power Spectral Density Measurement

4.5.1 Limits of Peak Power Spectral Density Measurement

Operation Band	EUT Category		LIMIT
U-NII-1	---	Outdoor Access Point	17dBm/ MHz
	---	Fixed point-to-point Access Point	
	---	Indoor Access Point	
	---	Mobile and Portable client device	11dBm/ MHz
U-NII-2A	---		11dBm/ MHz
U-NII-2C	---		11dBm/ MHz
U-NII-3	√		30dBm/ 500kHz

4.5.2 Test Setup

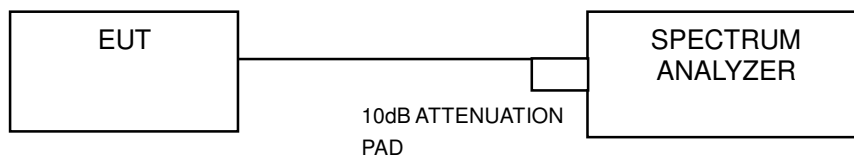

4.5.3 Test Instruments

Refer to section 4.1.2 to get information of above instrument.

4.5.4 Test Procedure

For U-NII-3 band:

- 1) Set span to encompass the entire emission bandwidth (EBW) of the signal.
- 2) Set RBW = 500 kHz, Set VBW \geq 3 RBW, Detector = RMS
- 3) Sweep time = auto, trigger set to "free run".
- 4) Trace average at least 100 traces in power averaging mode.
- 5) Record the max value and add $10 \log (1/\text{duty cycle})$

4.5.5 Deviation from Test Standard

No deviation.

4.5.6 EUT Operating Condition

Same as Item 4.3.6.

4.5.7 Test Results

For U-NII-3 Band

802.11a

TX chain	Channel	Freq. (MHz)	PSD (dBm/500kHz)	10 log (N=3) dB	DUTY FACTOR	Total PSD (dBm/500kHz)	Limit (dBm/500kHz)	PASS /FAIL
0	149	5745	12.46	4.77	0.42	17.65	28.18	PASS
	157	5785	11.95	4.77	0.42	17.14	28.18	PASS
	165	5825	11.98	4.77	0.42	17.17	28.18	PASS
1	149	5745	12.54	4.77	0.42	17.73	28.18	PASS
	157	5785	12.00	4.77	0.42	17.19	28.18	PASS
	165	5825	12.14	4.77	0.42	17.33	28.18	PASS
2	149	5745	12.48	4.77	0.42	17.67	28.18	PASS
	157	5785	12.07	4.77	0.42	17.26	28.18	PASS
	165	5825	12.12	4.77	0.42	17.31	28.18	PASS

NOTE:

1. Directional gain = $3.05\text{dBi} + 10\log(4.77) = 7.82\text{dBi} > 6\text{dBi}$, so the power density limit shall be reduced to $30 - (7.82 - 6) = 28.18\text{dBm}$.
2. Refer to section 3.3 for duty cycle spectrum plot.

802.11n (20MHz)

TX chain	Channel	Freq. (MHz)	PSD (dBm/500kHz)	10 log (N=3) dB	DUTY FACTOR	Total PSD (dBm/500kHz)	Limit (dBm/500kHz)	PASS /FAIL
0	149	5745	12.11	4.77	0.30	17.18	28.18	PASS
	157	5785	13.98	4.77	0.30	19.05	28.18	PASS
	165	5825	13.38	4.77	0.30	18.45	28.18	PASS
1	149	5745	12.28	4.77	0.30	17.35	28.18	PASS
	157	5785	13.95	4.77	0.30	19.02	28.18	PASS
	165	5825	13.25	4.77	0.30	18.32	28.18	PASS
2	149	5745	12.25	4.77	0.30	17.32	28.18	PASS
	157	5785	14.02	4.77	0.30	19.09	28.18	PASS
	165	5825	13.28	4.77	0.30	18.35	28.18	PASS

NOTE:

1. Directional gain = $3.05\text{dBi} + 10\log(4.77) = 7.82\text{dBi} > 6\text{dBi}$, so the power density limit shall be reduced to $30 - (7.82 - 6) = 28.18\text{dBm}$.
2. Refer to section 3.3 for duty cycle spectrum plot.

802.11n (40MHz)

TX chain	Channel	Freq. (MHz)	PSD (dBm/500kHz)	10 log (N=3) dB	DUTY FACTOR	Total PSD (dBm/500kHz)	Limit (dBm/500kHz)	PASS /FAIL
0	151	5755	8.11	4.77	0.70	13.58	28.18	PASS
	159	5795	10.55	4.77	0.70	16.02	28.18	PASS
1	151	5755	7.94	4.77	0.70	13.41	28.18	PASS
	159	5795	10.50	4.77	0.70	15.97	28.18	PASS
2	151	5755	7.92	4.77	0.70	13.39	28.18	PASS
	159	5795	10.48	4.77	0.70	15.95	28.18	PASS

NOTE:

1. Directional gain = $3.05\text{dBi} + 10\log(4.77) = 7.82\text{dBi} > 6\text{dBi}$, so the power density limit shall be reduced to $30 - (7.82 - 6) = 28.18\text{dBm}$.
2. Refer to section 3.3 for duty cycle spectrum plot.

802.11ac (80MHz)

TX chain	Channel	Freq. (MHz)	PSD (dBm/500kHz)	10 log (N=3) dB	DUTY FACTOR	Total PSD (dBm/500kHz)	Limit (dBm/500kHz)	PASS /FAIL
0	155	5775	3.79	4.77	1.25	9.81	28.18	PASS
1	155	5775	3.60	4.77	1.25	9.62	28.18	PASS
2	155	5775	3.67	4.77	1.25	9.69	28.18	PASS

NOTE:

1. Directional gain = $3.05\text{dBi} + 10\log(4.77) = 7.82\text{dBi} > 6\text{dBi}$, so the power density limit shall be reduced to $30 - (7.82 - 6) = 28.18\text{dBm}$.
2. Refer to section 3.3 for duty cycle spectrum plot.

SPECTRUM PLOT OF WORST VALUE

802.11a

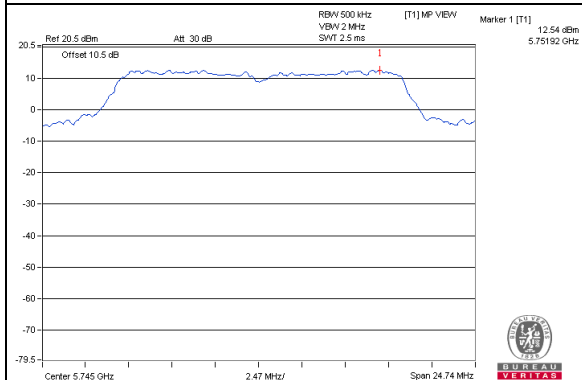

802.11n (20MHz)

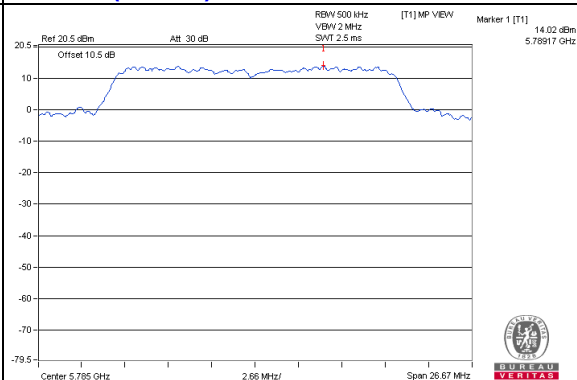

802.11n (40MHz)

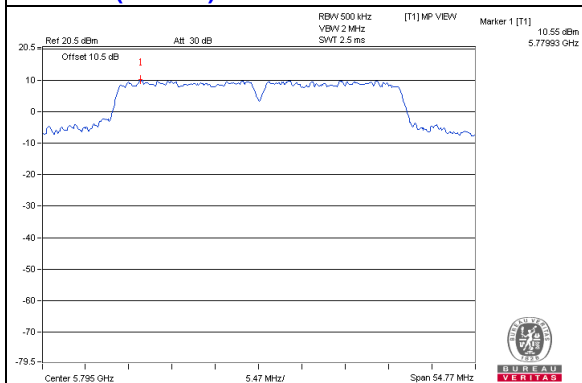

802.11ac (80MHz)

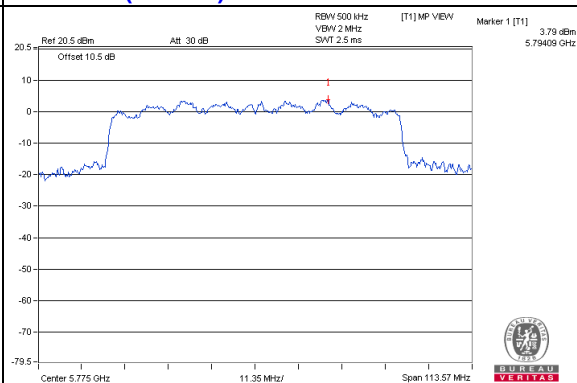

4.6 Frequency Stability Measurement

4.6.1 Limits of Frequency Stability Measurement

The frequency of the carrier signal shall be maintained within band of operation

4.6.2 Test Setup

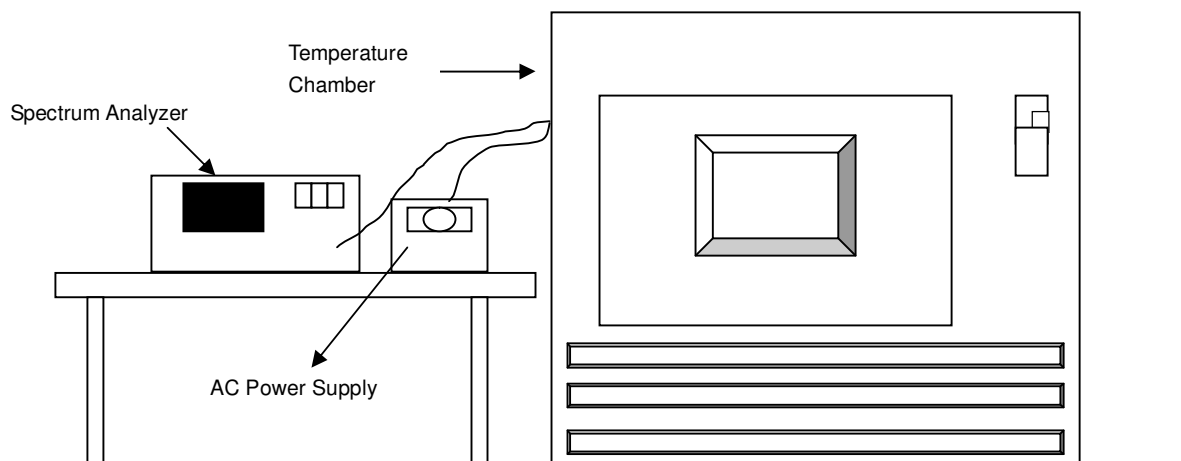

4.6.3 Test Instruments

Refer to section 4.1.2 to get information of above instrument.

4.6.4 Test Procedure

- The EUT was placed inside the environmental test chamber and powered by nominal AC voltage.
- Turn the EUT on and couple its output to a spectrum analyzer.
- Turn the EUT off and set the chamber to the highest temperature specified.
- Allow sufficient time (approximately 30 min) for the temperature of the chamber to stabilize, turn the EUT on and measure the operating frequency after 2, 5, and 10 minutes.
- Repeat step 2 and 3 with the temperature chamber set to the lowest temperature.
- The test chamber was allowed to stabilize at +20 degree C for a minimum of 30 minutes. The supply voltage was then adjusted on the EUT from 85% to 115% and the frequency record.

4.6.5 Deviation from Test Standard

No deviation.

4.6.6 EUT Operating Condition

Set the EUT transmit at un-modulation mode to test frequency stability.

4.6.7 Test Results

FREQUENCY STABILITY VERSUS TEMP.									
OPERATING FREQUENCY: 5745MHz									
TEMP. (°C)	POWER SUPPLY (Vac)	0 MINUTE		2 MINUTE		5 MINUTE		10 MINUTE	
		Measured Frequency (MHz)	Pass/Fail	Measured Frequency (MHz)	Pass/Fail	Measured Frequency (MHz)	Pass/Fail	Measured Frequency (MHz)	Pass/Fail
50	120	5745.0288	Pass	5745.0258	Pass	5745.0298	Pass	5745.0282	Pass
40	120	5745.0029	Pass	5744.9999	Pass	5745.0002	Pass	5745.0044	Pass
30	120	5745.0146	Pass	5745.0151	Pass	5745.0153	Pass	5745.019	Pass
20	120	5745.0009	Pass	5745.0024	Pass	5745.0012	Pass	5745.0001	Pass
10	120	5744.9988	Pass	5744.9988	Pass	5744.994	Pass	5744.9951	Pass
0	120	5744.9703	Pass	5744.9748	Pass	5744.9746	Pass	5744.9722	Pass
-10	120	5745.0292	Pass	5745.024	Pass	5745.0276	Pass	5745.028	Pass
-20	120	5745.0054	Pass	5745.0058	Pass	5745.0081	Pass	5745.0082	Pass
-30	120	5744.9739	Pass	5744.9783	Pass	5744.9738	Pass	5744.974	Pass

FREQUENCY STABILITY VERSUS VOLTAGE									
OPERATING FREQUENCY: 5745MHz									
TEMP. (°C)	POWER SUPPLY (Vac)	0 MINUTE		2 MINUTE		5 MINUTE		10 MINUTE	
		Measured Frequency (MHz)	Pass/Fail	Measured Frequency (MHz)	Pass/Fail	Measured Frequency (MHz)	Pass/Fail	Measured Frequency (MHz)	Pass/Fail
20	138	5745.0007	Pass	5745.0017	Pass	5745.0011	Pass	5745.0003	Pass
	120	5745.0009	Pass	5745.0024	Pass	5745.0012	Pass	5745.0001	Pass
	102	5745.0018	Pass	5745.002	Pass	5745.0005	Pass	5745.0003	Pass

4.7 6dB Bandwidth Measurement

4.7.1 Limits of 6dB Bandwidth Measurement

The minimum of 6dB Bandwidth Measurement is 0.5MHz.

4.7.2 Test Setup

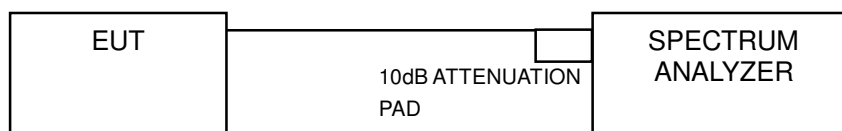

4.7.3 Test Instruments

Refer to section 4.1.2 to get information of above instrument.

4.7.4 Test Procedure

MEASUREMENT PROCEDURE REF

- Set resolution bandwidth (RBW) = 100kHz
- Set the video bandwidth (VBW) $\geq 3 \times$ RBW, Detector = Peak.
- Trace mode = max hold.
- Sweep = auto couple.
- Measure the maximum width of the emission that is constrained by the frequencies associated with the two amplitude points (upper and lower) that are attenuated by 6 dB relative to the maximum level measured in the fundamental emission

4.7.5 Deviation from Test Standard

No deviation.

4.7.6 EUT Operating Condition

The software provided by client to enable the EUT under transmission condition continuously at lowest, middle and highest channel frequencies individually.

4.7.7 Test Results

802.11a

CHANNEL	FREQUENCY (MHz)	6dB BANDWIDTH (MHz)			MINIMUM LIMIT (MHz)	PASS / FAIL
		CHAIN 0	CHAIN 1	CHAIN 2		
149	5745	16.49	16.49	16.49	0.5	PASS
157	5785	16.49	16.49	16.49	0.5	PASS
165	5825	16.49	16.50	16.49	0.5	PASS

802.11n (20MHz)

CHANNEL	FREQUENCY (MHz)	6dB BANDWIDTH (MHz)			MINIMUM LIMIT (MHz)	PASS / FAIL
		CHAIN 0	CHAIN 1	CHAIN 2		
149	5745	17.74	17.76	17.76	0.5	PASS
157	5785	17.77	17.77	17.78	0.5	PASS
165	5825	17.78	17.78	17.79	0.5	PASS

802.11n (40MHz)

CHANNEL	FREQUENCY (MHz)	6dB BANDWIDTH (MHz)			MINIMUM LIMIT (MHz)	PASS / FAIL
		CHAIN 0	CHAIN 1	CHAIN 2		
151	5755	36.53	36.54	36.53	0.5	PASS
159	5795	36.51	36.52	36.53	0.5	PASS

802.11ac (80MHz)

CHANNEL	FREQUENCY (MHz)	6dB BANDWIDTH (MHz)			MINIMUM LIMIT (MHz)	PASS / FAIL
		CHAIN 0	CHAIN 1	CHAIN 2		
155	5775	75.71	75.94	75.92	0.5	PASS

SPECTRUM PLOT OF WORST VALUE

802.11a

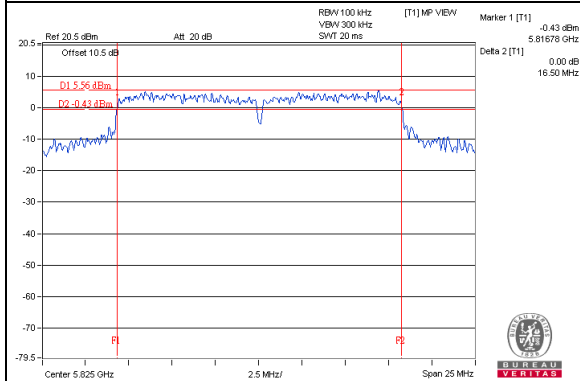

802.11n (20MHz)

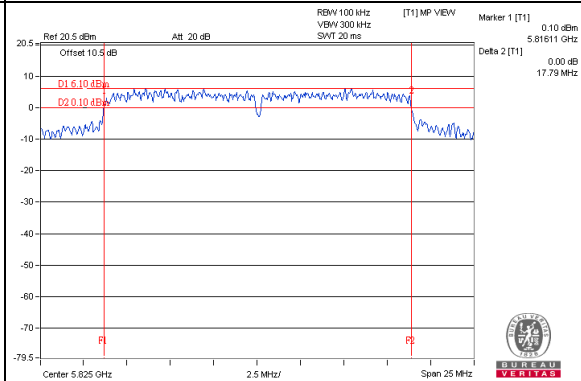

802.11n (40MHz)

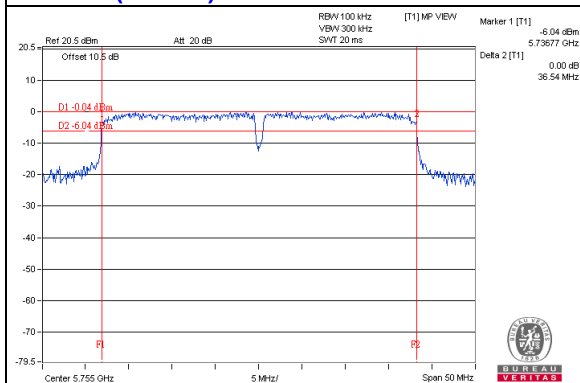

802.11ac (80MHz)

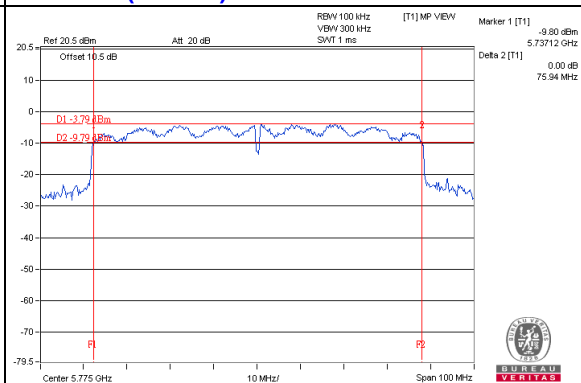

5 Pictures of Test Arrangements

Please refer to the attached file (Test Setup Photo).

Annex A - Radiated Out of Band Emission (OOBE) Measurement (For U-NII-3 band)

802.11a

CH 149 5745 MHz

Horizontal

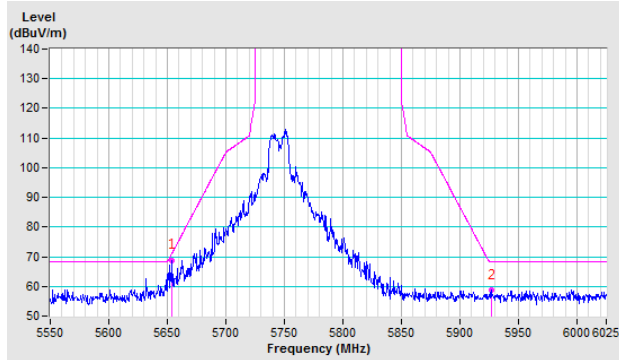

Vertical

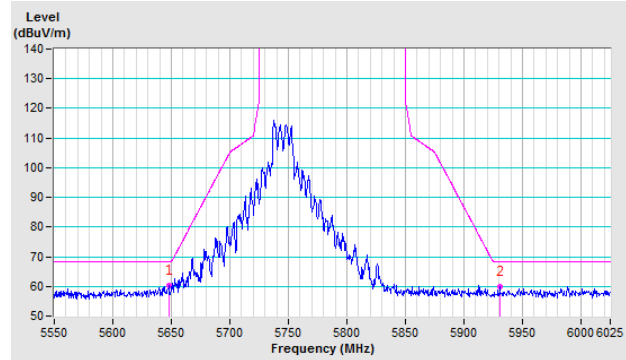

CH 157 5785 MHz

Horizontal

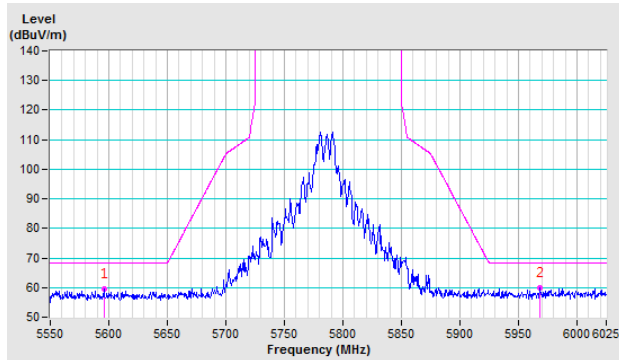

Vertical

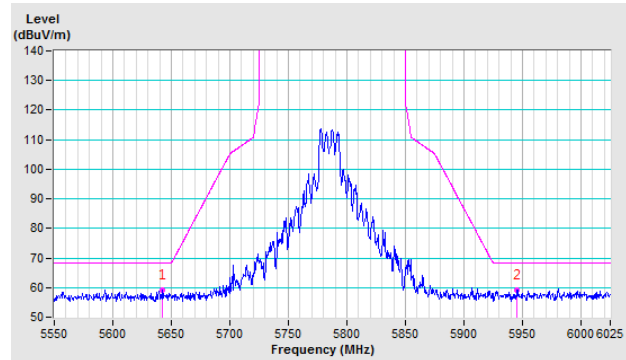

CH 165 5825 MHz

Horizontal

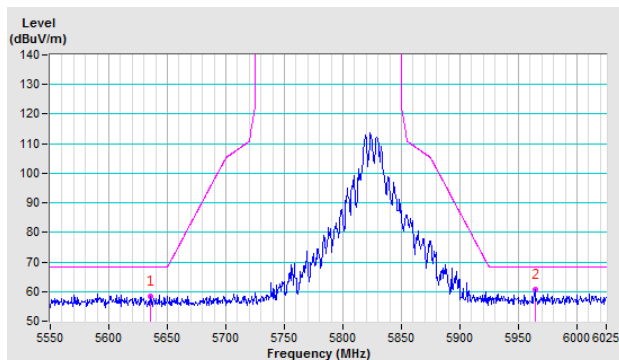

Vertical

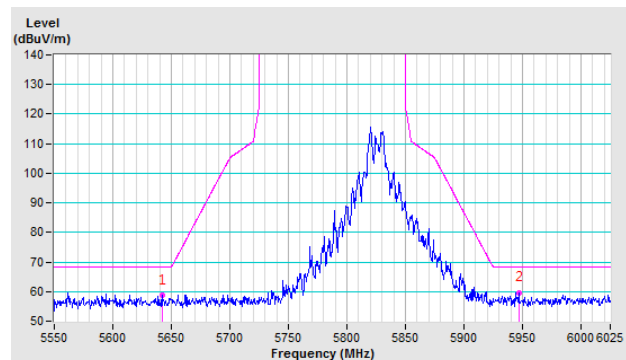

802.11n (20MHz)

CH 149 5745 MHz

Horizontal

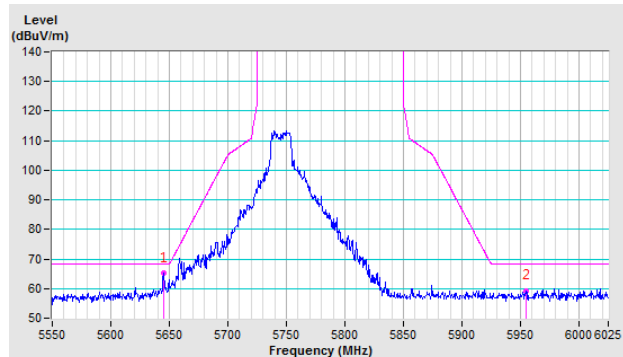

Vertical

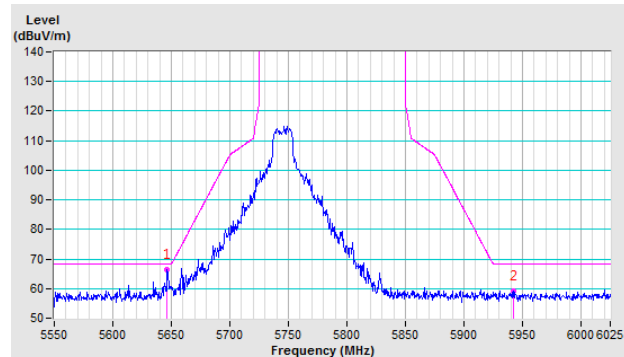

CH 157 5785 MHz

Horizontal

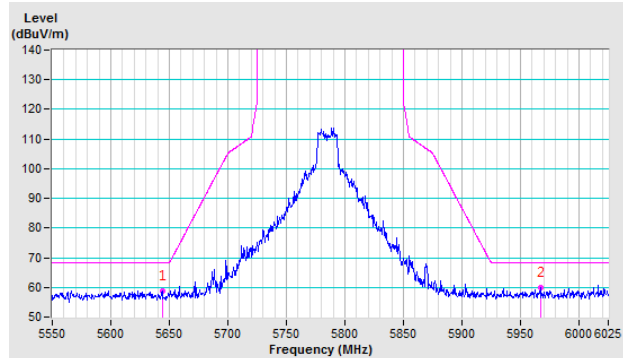

Vertical

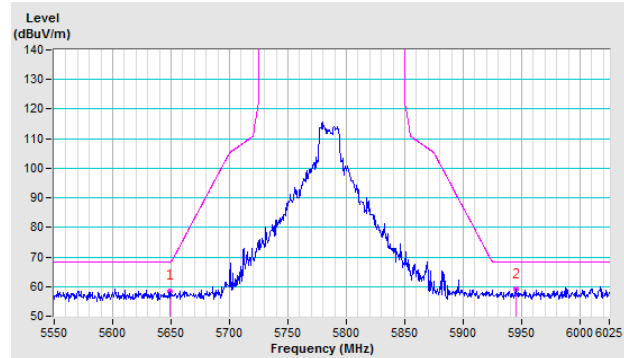

CH 165 5825 MHz

Horizontal

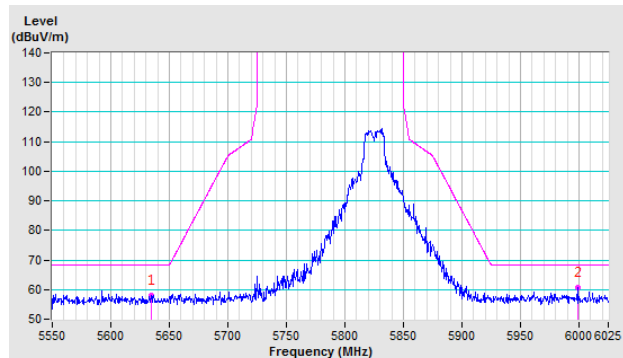

Vertical

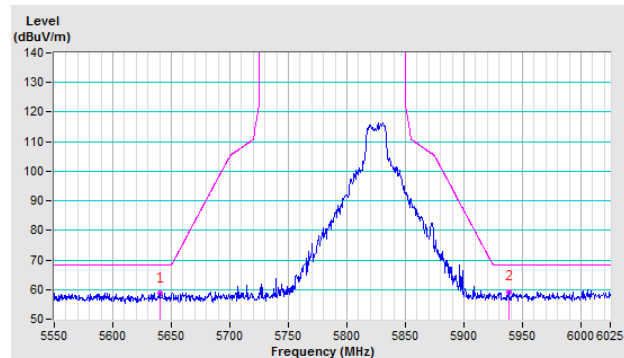

802.11n (40MHz)

CH 151 5755 MHz

Horizontal

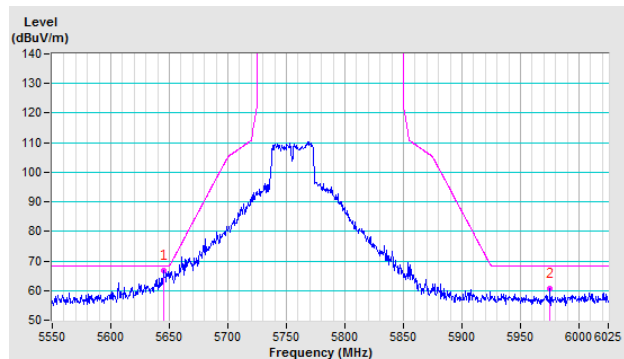

Vertical

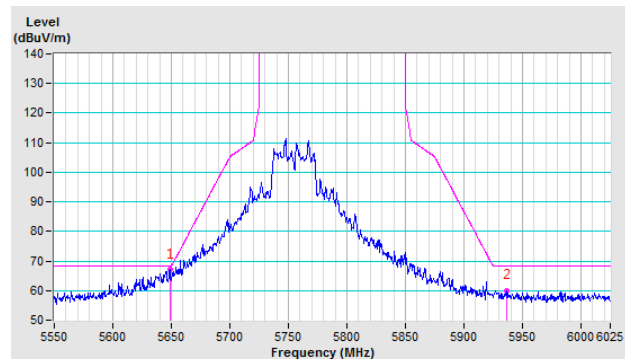

CH 159 5795 MHz

Horizontal

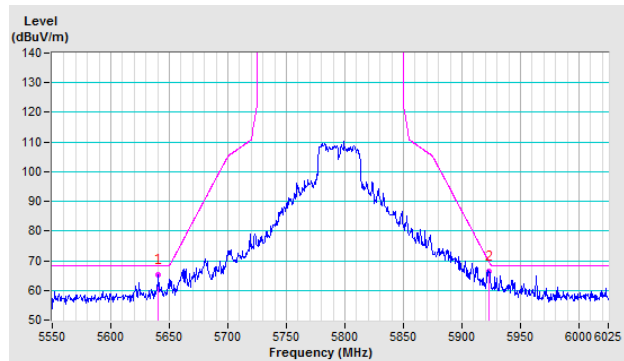

Vertical

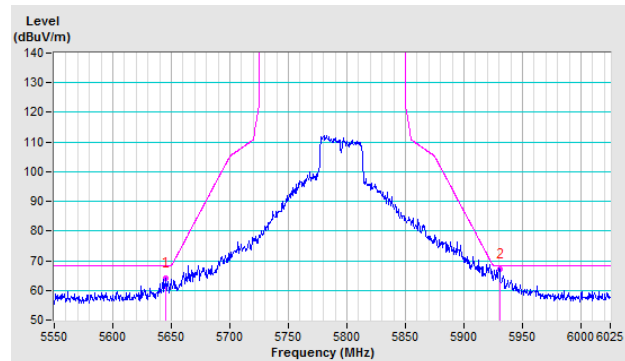

802.11ac (80MHz)

CH 155 5775 MHz

Horizontal

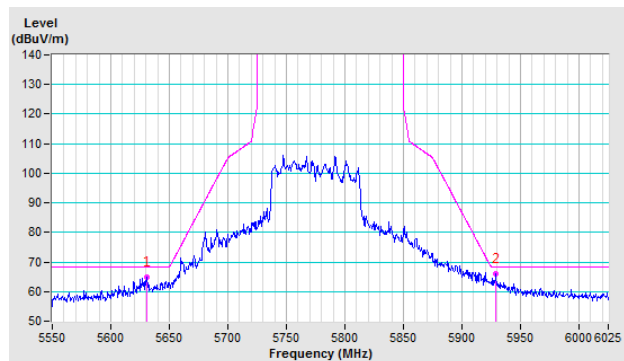

Vertical

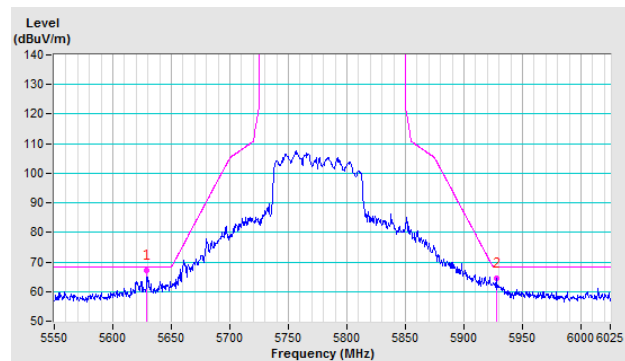

Appendix – Information on the Testing Laboratories

We, Bureau Veritas Consumer Products Services (H.K.) Ltd., Taoyuan Branch, were founded in 1988 to provide our best service in EMC, Radio, Telecom and Safety consultation. Our laboratories are accredited and approved according to ISO/IEC 17025.

If you have any comments, please feel free to contact us at the following:

Linko EMC/RF Lab

Tel: 886-2-26052180

Fax: 886-2-26051924

Hsin Chu EMC/RF/Telecom Lab

Tel: 886-3-6668565

Fax: 886-3-6668323

Hwa Ya EMC/RF/Safety Lab

Tel: 886-3-3183232

Fax: 886-3-3270892

Email: service.adt@tw.bureauveritas.com

Web Site: www.bureauveritas-adt.com

The address and road map of all our labs can be found in our web site also.

--- END ---