

## FCC Test Report

**Report No.:** RF180105C16

**FCC ID:** K7SF8Z880

**Test Model:** F8Z880tt

**Received Date:** Jan. 05, 2018

**Test Date:** Jan. 11 ~ Mar. 07, 2018

**Issued Date:** Mar. 09, 2018

**Applicant:** Belkin International, Inc.

**Address:** 12045 E. Waterfront Drive, Playa Vista, CA 90094 USA

**Issued By:** Bureau Veritas Consumer Products Services (H.K.) Ltd., Taoyuan Branch

**Lab Address:** No. 47-2, 14th Ling, Chia Pau Vil., Lin Kou Dist., New Taipei City, Taiwan, R.O.C.

**Test Location:** No. 19, Hwa Ya 2nd Rd., Wen Hwa Vil., Kwei Shan Dist., Taoyuan City 33383, TAIWAN (R.O.C.)

**FCC Registration:** 788550

**Designation Number:** TW0003



This report is for your exclusive use. Any copying or replication of this report to or for any other person or entity, or use of our name or trademark, is permitted only with our prior written permission. This report sets forth our findings solely with respect to the test samples identified herein. The results set forth in this report are not indicative or representative of the quality or characteristics of the lot from which a test sample was taken or any similar or identical product unless specifically and expressly noted. Our report includes all of the tests requested by you and the results thereof based upon the information that you provided to us. You have 60 days from date of issuance of this report to notify us of any material error or omission caused by our negligence, provided, however, that such notice shall be in writing and shall specifically address the issue you wish to raise. A failure to raise such issue within the prescribed time shall constitute your unqualified acceptance of the completeness of this report, the tests conducted and the correctness of the report contents. Unless specifically mentioned, the uncertainty of measurement has been explicitly taken into account to declare the compliance or non-compliance to the specification. The report must not be used by the client to claim product certification, approval, or endorsement by TAF or any government agencies.

## Table of Contents

<b>Release Control Record</b> .....	<b>3</b>
<b>1 Certificate of Conformity</b> .....	<b>4</b>
<b>2 Summary of Test Results</b> .....	<b>5</b>
2.1 Measurement Uncertainty.....	5
2.2 Modification Record.....	5
<b>3 General Information</b> .....	<b>6</b>
3.1 General Description of EUT.....	6
3.2 Description of Test Modes.....	6
3.2.1 Test Mode Applicability and Tested Channel Deta.....	7
3.3 Description of Support Units.....	8
3.3.1 Configuration of System under Test.....	8
3.4 General Description of Applied Standards.....	9
<b>4 Test Types and Results</b> .....	<b>10</b>
4.1 Radiated Emission Measurement.....	10
4.1.1 Limits of Radiated Emission Measurement.....	10
4.1.2 Test Instruments.....	11
4.1.3 Test Procedures.....	12
4.1.4 Deviation from Test Standard.....	12
4.1.5 Test Set Up.....	13
4.1.6 EUT Operating Conditions.....	14
4.1.7 Test Results.....	15
4.2 Occupied Bandwidth Measurement.....	23
4.2.1 Limits of Occupied Bandwidth Measurement.....	23
4.2.2 Test Setup.....	23
4.2.3 Test Instruments.....	23
4.2.4 Test Procedures.....	23
4.2.5 Deviation from Test Standard.....	23
4.2.6 EUT Operating Conditions.....	23
4.2.7 Test Results.....	24
<b>5 Pictures of Test Arrangements</b> .....	<b>25</b>
<b>Appendix – Information on the Testing Laboratories</b> .....	<b>26</b>

### Release Control Record

Issue No.	Description	Date Issued
RF180105C16	Original release	Mar. 09, 2018

## 1 Certificate of Conformity

**Product:** tunecast auto

**Brand:** belkin

**Test Model:** F8Z880tt

**Sample Status:** Engineering sample

**Applicant:** Belkin International, Inc.

**Test Date:** Jan. 11 ~ Mar. 07, 2018

**Standards:** 47 CFR FCC Part 15, Subpart C (Section 15.239)  
ANSI C63.10:2013

The above equipment has been tested by **Bureau Veritas Consumer Products Services (H.K.) Ltd., Taoyuan Branch**, and found compliance with the requirement of the above standards. The test record, data evaluation & Equipment Under Test (EUT) configurations represented herein are true and accurate accounts of the measurements of the sample's RF characteristics under the conditions specified in this report.

**Prepared by :** , **Date:** Mar. 09, 2018  
Pettie Chen / Senior Specialist

**Approved by :** , **Date:** Mar. 09, 2018  
Bruce Chen / Project Engineer

## 2 Summary of Test Results

47 CFR FCC Part 15, Subpart C (Section 15.239)			
FCC Clause	Test Item	Result	Remarks
15.207	AC Power Conducted Emission	Pass	Power supply is 12Vdc from battery
15.209 15.239(b) 15.239(c)	Radiated Emission Test	Pass	Meet the requirement of limit. Minimum passing margin is -2.90dB at 35.99MHz.
15.239(a)	Occupied Bandwidth Measurement	Pass	Meet the requirement of limit.

### 2.1 Measurement Uncertainty

Where relevant, the following measurement uncertainty levels have been estimated for tests performed on the EUT as specified in CISPR 16-4-2:

Measurement	Frequency	Expanded Uncertainty (k=2) ( $\pm$ )
Radiated Emissions up to 1 GHz	30MHz ~ 200MHz	3.86 dB
	200MHz ~1000MHz	3.87 dB
	1GHz ~ 18GHz	2.29 dB
	18GHz ~ 40GHz	2.29 dB

### 2.2 Modification Record

There were no modifications required for compliance.

### 3 General Information

#### 3.1 General Description of EUT

Product	tunecast auto
Brand	belkin
Test Model	F8Z880tt
Sample Status	Engineering sample
Power Supply Rating	12Vdc
Modulation Type	FM
Operating Frequency	88.1~107.9MHz
Antenna Type	PCB antenna with 0dBi gain
Accessory Device	NA
Power Cable	0.58m non-shielded power cable without core
Data Cable Supplied	0.53m non-shielded Audio cable without core

Note: The following samples are provided to test.

Sample No.	Test item
C180206-017-007-007	Radiated Emission
C180301-015-005-002	
C180103-029-012-010	
C180103-029-012-003	Occupied Bandwidth

#### 3.2 Description of Test Modes

The tuning range has been manually verified and the device can work only within 88 ~ 108 MHz band.

The low, middle and high channels are chosen for testing.

Channel	Freq.
Low channel (L)	88.1MHz
Middle channel (M)	98.1MHz
High channel (H)	107.9MHz

### 3.2.1 Test Mode Applicability and Tested Channel Data

EUT Configure Mode	Applicable to				Description
	RE ≥ 1G	RE < 1G	PLC	OB	
-	√	√	Note 2	√	-

Where **RE≥1G**: Radiated Emission above 1GHz  
**RE<1G**: Radiated Emission below 1GHz  
**PLC**: Power Line Conducted Emission  
**OB**: Occupied Bandwidth measurement

Note:

- The antenna had been pre-tested on the positioned of each 3 axis. The worst cases were found when positioned on Y-plane.
- No need to concern of Conducted Emission due to the EUT is powered by battery

#### Radiated Emission Test (Above 1GHz):

- Pre-Scan has been conducted to determine the worst-case mode from all possible combinations between available modulations, data rates and antenna ports (if EUT with antenna diversity architecture).
- Following channel(s) was (were) selected for the final test as listed below.

EUT Configure Mode	Available Frequency (MHz)	Operating Frequency	Modulation Type
-	88.1 – 107.9	88.1, 98.1, 107.9MHz	FM

#### Radiated Emission Test (Below 1GHz):

- Pre-Scan has been conducted to determine the worst-case mode from all possible combinations between available modulations, data rates and antenna ports (if EUT with antenna diversity architecture).
- Following channel(s) was (were) selected for the final test as listed below.

EUT Configure Mode	Available Frequency (MHz)	Operating Frequency	Modulation Type
-	88.1 – 107.9	88.1, 98.1, 107.9MHz	FM

#### Occupied Bandwidth Measurement:

- Pre-Scan has been conducted to determine the worst-case mode from all possible combinations between available modulations, data rates and antenna ports (if EUT with antenna diversity architecture).
- Following channel(s) was (were) selected for the final test as listed below.

EUT Configure Mode	Available Frequency (MHz)	Operating Frequency	Modulation Type
-	88.1 – 107.9	88.1, 98.1, 107.9MHz	FM

#### Test Condition:

Applicable to	Environmental Conditions	Input Power	Tested by
RE≥1G	21 deg. C, 69% RH	12Vdc	Adair Peng
RE<1G	22 deg. C, 66% RH	12Vdc	Adair Peng
OB	23 deg. C, 68% RH	12Vdc	Chris Lin

### 3.3 Description of Support Units

The EUT has been tested as an independent unit together with other necessary accessories or support units. The following support units or accessories were used to form a representative test configuration during the tests.

ID	Product	Brand	Model No.	Serial No.	FCC ID	Remarks
A.	Moblie Phone	SONY	LT28H	CB5A1KY97P	NA	-
B.	Earphone	NA	NA	NA	NA	-
C.	iPod shuffle	apple	A1204	4H814FEGYX6	FCC DoC Approved	-
D.	Tablet	SAMSUNG	SM-T520	RF2F401FVSL 16GB	NA	-
E.	Battery	YUASA	NA	NA	NA	-
F.	DC plug	NA	NA	NA	NA	-

Note:

1. All power cords of the above support units are non-shielded (1.8m).
2. Item D, E was placed under the testing table.

ID	Descriptions	Qty.	Length (m)	Shielding (Yes/No)	Cores (Qty.)	Remarks
1.	DC cable	1	0.5	N	0	-
2.	Audio cable	1	1.2	N	0	-
3.	Micro USB cable	1	1.0	Y	0	-
4.	DC cable	1	1.2	N	0	-
5.	Audio cable	1	0.75	N	0	-

#### 3.3.1 Configuration of System under Test

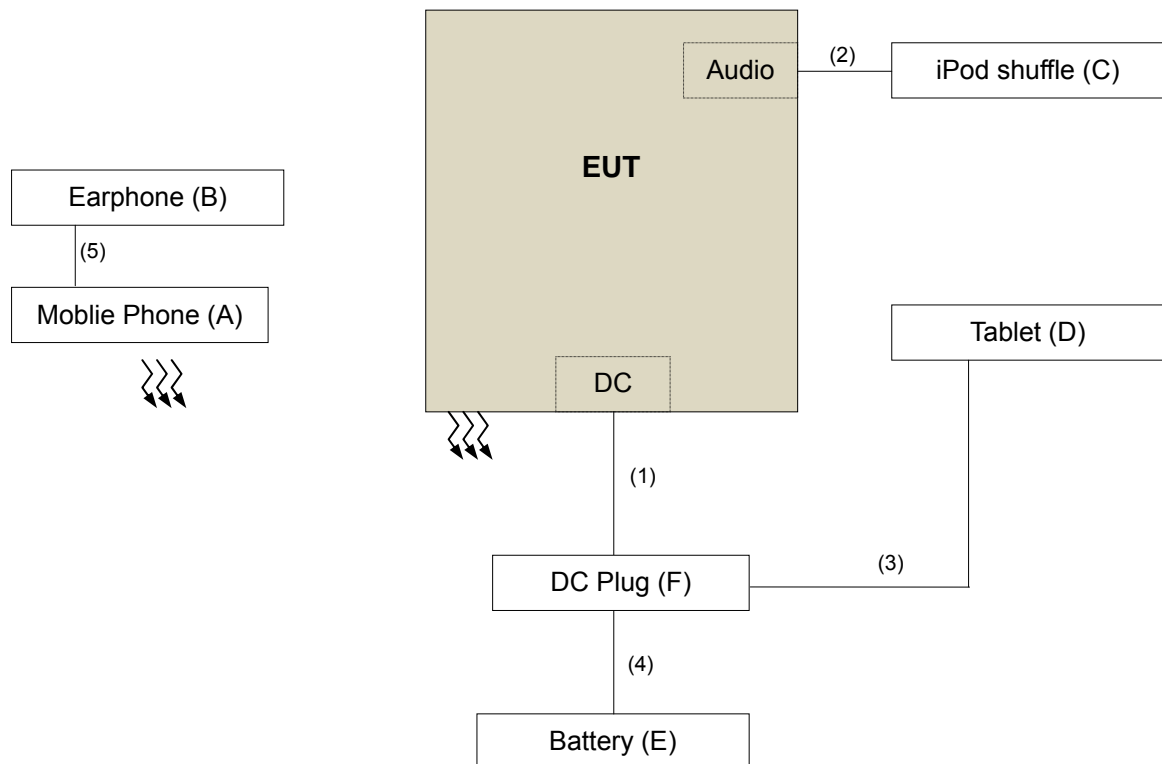



### 3.4 General Description of Applied Standards

The EUT is a RF Product. According to the specifications of the manufacturer, it must comply with the requirements of the following standards:

**FCC Part 15, Subpart C (15.239)**  
**ANSI C63.4- 2003**

All test items have been performed and recorded as per the above standards.

## 4 Test Types and Results

### 4.1 Radiated Emission Measurement

#### 4.1.1 Limits of Radiated Emission Measurement

(a) According to FCC 15.239 the field strength of any emissions within the permitted 200 kHz band shall not exceed the following:

Fundamental frequency (MHz)	Field strength of fundamental (dBuV/m)	
	Peak	Average
88 to 108	68	48

(b) The field strength of any emissions radiated on any frequency outside of the specified 200 kHz band shall not exceed the general radiated emission limits in §15.209 as following:

Frequencies (MHz)	Field Strength (microvolts/meter)	Measurement Distance (meters)
0.009 ~ 0.490	2400/F(kHz)	300
0.490 ~ 1.705	24000/F(kHz)	30
1.705 ~ 30.0	30	30
30 ~ 88	100	3
88 ~ 216	150	3
216 ~ 960	200	3
Above 960	500	3

**NOTE:**

1. The lower limit shall apply at the transition frequencies.
2. Emission level (dBuV/m) = 20 log Emission level (uV/m).
3. For frequencies above 1000MHz, the field strength limits are based on average detector, however, the peak field strength of any emission shall not exceed the maximum permitted average limits, specified above by more than 20dB under any condition of modulation.

#### 4.1.2 Test Instruments

Description & Manufacturer	Model No.	Serial No.	Cal. Date	Cal. Due
Test Receiver ROHDE & SCHWARZ	ESIB7	100187	May 02, 2017	May 01, 2018
Spectrum Analyzer ROHDE & SCHWARZ	FSP40	100041	Dec. 12, 2017	Dec. 11, 2018
BILOG Antenna SCHWARZBECK	VULB9168	9168-171	Dec. 11, 2017	Dec. 10, 2018
HORN Antenna SCHWARZBECK	9120D	209	Dec. 13, 2017	Dec. 12, 2018
HORN Antenna SCHWARZBECK	BBHA 9170	BBHA9170241	Dec. 01, 2017	Nov. 30, 2018
Loop Antenna EMCI	EM-6879	269	Aug. 11, 2017	Aug. 10, 2018
Preamplifier Agilent (Below 1GHz)	8447D	2944A10738	Aug. 21, 2017	Aug. 20, 2018
Preamplifier Agilent (Above 1GHz)	8449B	3008A02465	Apr. 05, 2017	Apr. 04, 2018
RF signal cable HUBER+SUHNER	SUCOFLEX 104	Cable-CH3-03 (223653/4)	Aug. 21, 2017	Aug. 20, 2018
RF signal cable HUBER+SUHNER& EMCI	SUCOFLEX 104&EMC104-SM-S M-8000	Cable-CH3-03 (309224+170907)	Sep.11, 2017	Sep. 10, 2018
Software BV ADT	ADT_Radiated_ V7.6.15.9.4	NA	NA	NA
Antenna Tower inn-co GmbH	MA 4000	013303	NA	NA
Antenna Tower Controller BV ADT	AT100	AT93021702	NA	NA
Turn Table BV ADT	TT100	TT93021702	NA	NA
Turn Table Controller BV ADT	SC100	SC93021702	NA	NA

- Note:
1. The calibration interval of the above test instruments is 12 months and the calibrations are traceable to NML/ROC and NIST/USA.
  2. The test was performed in HwaYa Chamber 3.
  3. The horn antenna and preamplifier (model: 8449B) are used only for the measurement of emission frequency above 1GHz if tested.
  4. The FCC Designation Number is TW0003. The number will be varied with the Lab location and scope as attached.
  5. The IC Site Registration No. is IC 7450F-3.

### 4.1.3 Test Procedures

#### For Radiated emission below 30MHz

- a. The EUT was placed on the top of a rotating table 0.8 meters above the ground at a 3 meter chamber room. The table was rotated 360 degrees to determine the position of the highest radiation.
- b. The EUT was set 3 meters away from the interference-receiving antenna, which was mounted on the top of a variable-height antenna tower.
- c. Both X and Y axes of the antenna are set to make the measurement.
- d. For each suspected emission, the EUT was arranged to its worst case and the rotatable table was turned from 0 degrees to 360 degrees to find the maximum reading.
- e. The test-receiver system was set to Quasi-Peak Detect Function and Specified Bandwidth with Maximum Hold Mode.

#### Note:

1. The resolution bandwidth and video bandwidth of test receiver/spectrum analyzer is 9kHz at frequency below 30MHz.

#### For Radiated emission above 30MHz

- a. The EUT was placed on the top of a rotating table 0.8 meters (for 30MHz ~ 1GHz) / 1.5 meters (for above 1GHz) above the ground at 3 meter chamber room for test. The table was rotated 360 degrees to determine the position of the highest radiation.
- b. The EUT was set 3 meters away from the interference-receiving antenna, which was mounted on the top of a variable-height antenna tower.
- c. The height of antenna is varied from one meter to four meters above the ground to determine the maximum value of the field strength. Both horizontal and vertical polarizations of the antenna are set to make the measurement.
- d. For each suspected emission, the EUT was arranged to its worst case and then the antenna was tuned to heights from 1 meter to 4 meters and the rotatable table was turned from 0 degrees to 360 degrees to find the maximum reading.
- e. The test-receiver system was set to quasi-peak detect function and specified bandwidth with maximum hold mode when the test frequency is below 1 GHz.
- f. The test-receiver system was set to peak and average detect function and specified bandwidth with maximum hold mode when the test frequency is above 1 GHz. If the peak reading value also meets average limit, measurement with the average detector is unnecessary.

#### Note:

1. The resolution bandwidth and video bandwidth of test receiver/spectrum analyzer is 120kHz for Quasi-peak detection (QP) at frequency below 1GHz.
2. The resolution bandwidth of test receiver/spectrum analyzer is 1 MHz and the video bandwidth is 3 MHz for Peak detection (PK) at frequency above 1GHz.
3. The resolution bandwidth of test receiver/spectrum analyzer is 1MHz and the video bandwidth is  $\geq 1/T$  (Duty cycle < 98%) or 10Hz (Duty cycle  $\geq 98\%$ ) for Average detection (AV) at frequency above 1GHz.
4. All modes of operation were investigated and the worst-case emissions are reported.

### 4.1.4 Deviation from Test Standard

No deviation.

#### 4.1.5 Test Set Up

##### For Radiated emission below 30MHz

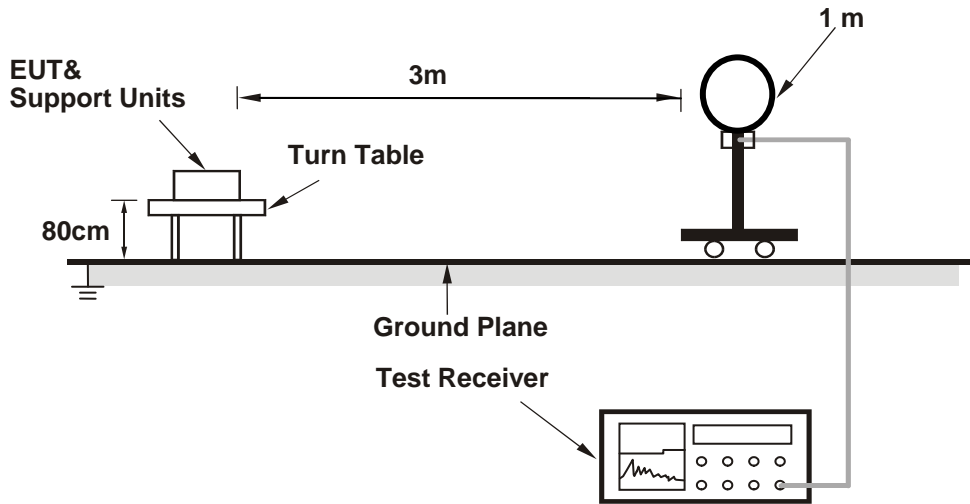

##### For Radiated emission 30MHz to 1GHz

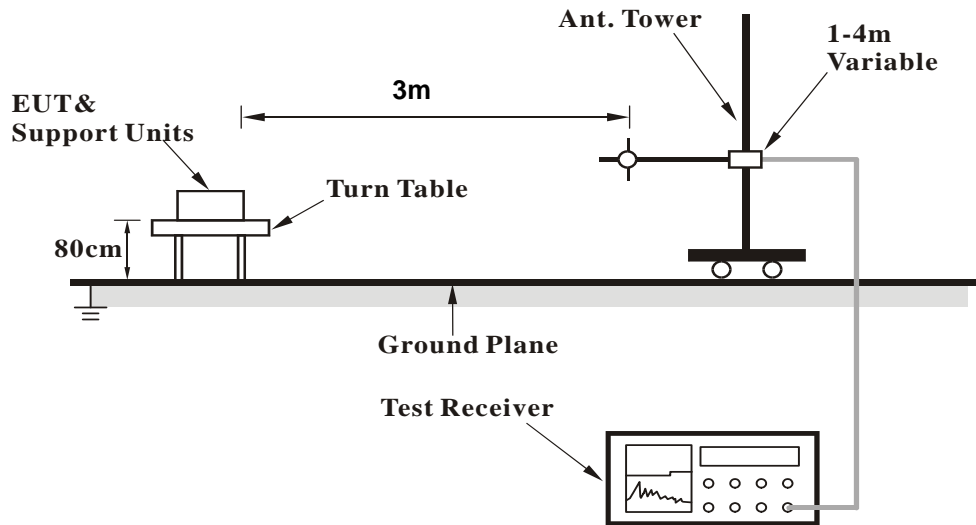

### For Radiated emission above 1GHz

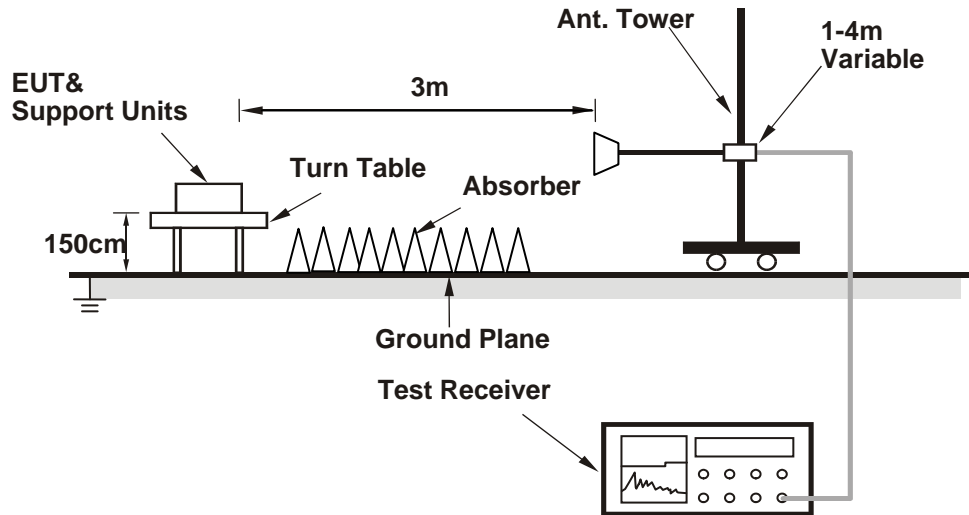

For the actual test configuration, please refer to the attached file (Test Setup Photo).

#### 4.1.6 EUT Operating Conditions

- a. Set the EUT under transmission condition continuously at specific channel frequency.

#### 4.1.7 Test Results

EUT Test Condition		Measurement Detail	
Channel	Channel 1	Frequency Range	Below 1000MHz
Input Power	12Vdc	Detector Function	Peak (PK) Average (AV) Quasi-Peak (QP)
Environmental Conditions	22 deg. C, 66% RH	Tested By	Adair Peng
Sample No:	C180206-017-007-007		

Antenna Polarity & Test Distance: Horizontal At 3m								
No.	Freq. (MHz)	Emission Level (dBuV/m)	Limit (dBuV/m)	Margin (dB)	Antenna Height (m)	Table Angle (Degree)	Raw Value (dBuV)	Correction Factor (dB/m)
1	35.73	32.0 PK	40.0	-8.0	1.99 H	19	47.7	-15.6
2	88.00	34.9 QP	40.0	-5.1	2.10 H	109	54.4	-19.5
3	88.10	41.9 PK	68.0	-26.1	1.99 H	120	61.4	-19.5
4	88.10	41.4 AV	48.0	-6.6	1.99 H	120	60.9	-19.5
5	175.72	24.7 PK	43.5	-18.8	1.49 H	329	39.3	-14.6
6	521.81	26.3 PK	46.0	-19.7	1.49 H	218	35.4	-9.1
7	589.86	28.3 PK	46.0	-17.7	1.49 H	138	35.9	-7.6

Antenna Polarity & Test Distance: Vertical At 3m								
No.	Freq. (MHz)	Emission Level (dBuV/m)	Limit (dBuV/m)	Margin (dB)	Antenna Height (m)	Table Angle (Degree)	Raw Value (dBuV)	Correction Factor (dB/m)
<b>1</b>	<b>35.99</b>	<b>37.1 PK</b>	<b>40.0</b>	<b>-2.9</b>	<b>1.00 V</b>	<b>99</b>	<b>52.7</b>	<b>-15.6</b>
2	88.00	35.3 QP	40.0	-4.7	1.00 V	97	54.8	-19.5
3	88.10	41.8 PK	68.0	-26.2	1.00 V	79	61.3	-19.5
4	88.10	41.7 AV	48.0	-6.3	1.00 V	79	61.2	-19.5
5	175.72	24.4 PK	43.5	-19.1	1.00 V	187	39.1	-14.6
6	350.71	22.6 PK	46.0	-23.4	1.99 V	305	34.7	-12.1
7	529.58	23.0 PK	46.0	-23.0	1.50 V	178	32.1	-9.1

Remarks:

1. Emission Level(dBuV/m) = Raw Value(dBuV) + Correction Factor(dB/m)
2. Correction Factor(dB/m) = Antenna Factor(dB/m) + Cable Factor(dB)
3. The other emission levels were very low against the limit.
4. Margin value = Emission Level – Limit value

EUT Test Condition		Measurement Detail	
Channel	Channel 2	Frequency Range	Below 1000MHz
Input Power	12Vdc	Detector Function	Peak (PK) Average (AV) Quasi-Peak (QP)
Environmental Conditions	22 deg. C, 66% RH	Tested By	Adair Peng
Sample No:	C180206-017-007-007		

Antenna Polarity & Test Distance: Horizontal At 3m								
No.	Freq. (MHz)	Emission Level (dBuV/m)	Limit (dBuV/m)	Margin (dB)	Antenna Height (m)	Table Angle (Degree)	Raw Value (dBuV)	Correction Factor (dB/m)
1	98.10	41.3 PK	68.0	-26.7	1.99 H	176	59.9	-18.6
2	98.10	38.8 AV	48.0	-9.2	1.99 H	176	57.4	-18.6
3	132.95	28.2 PK	43.5	-15.3	1.99 H	251	43.3	-15.2
4	195.16	22.4 PK	43.5	-21.1	1.50 H	213	39.1	-16.7
5	539.30	25.5 PK	46.0	-20.5	1.50 H	322	34.5	-9.0
6	914.55	39.1 PK	46.0	-6.9	1.00 H	246	41.4	-2.2
Antenna Polarity & Test Distance: Vertical At 3m								
No.	Freq. (MHz)	Emission Level (dBuV/m)	Limit (dBuV/m)	Margin (dB)	Antenna Height (m)	Table Angle (Degree)	Raw Value (dBuV)	Correction Factor (dB/m)
1	39.62	23.9 PK	40.0	-16.1	1.00 V	101	38.9	-15.0
2	98.10	40.5 PK	68.0	-27.5	1.00 V	93	59.1	-18.6
3	98.10	37.7 AV	48.0	-10.3	1.00 V	93	56.3	-18.6
4	379.87	19.7 PK	46.0	-26.3	1.99 V	35	31.2	-11.4
5	515.97	23.4 PK	46.0	-22.6	1.00 V	151	32.5	-9.1
6	729.84	30.4 PK	46.0	-15.6	1.49 V	16	35.6	-5.2

Remarks:

1. Emission Level(dBuV/m) = Raw Value(dBuV) + Correction Factor(dB/m)
2. Correction Factor(dB/m) = Antenna Factor(dB/m) + Cable Factor(dB)
3. The other emission levels were very low against the limit.
4. Margin value = Emission Level – Limit value



EUT Test Condition		Measurement Detail	
Channel	Channel 3	Frequency Range	Below 1000MHz
Input Power	12Vdc	Detector Function	Peak (PK) Average (AV) Quasi-Peak (QP)
Environmental Conditions	22 deg. C, 66% RH	Tested By	Adair Peng
Sample No:	C180206-017-007-007		

Antenna Polarity & Test Distance: Horizontal At 3m								
No.	Freq. (MHz)	Emission Level (dBuV/m)	Limit (dBuV/m)	Margin (dB)	Antenna Height (m)	Table Angle (Degree)	Raw Value (dBuV)	Correction Factor (dB/m)
1	107.90	38.0 PK	68.0	-30.0	1.50 H	229	55.5	-17.5
2	107.90	36.1 AV	48.0	-11.9	1.50 H	229	53.6	-17.5
3	108.00	36.8 QP	43.5	-6.7	1.50 H	209	54.2	-17.5
4	138.78	26.6 PK	43.5	-16.9	1.99 H	279	41.2	-14.6
5	416.81	22.9 PK	46.0	-23.1	1.99 H	100	33.8	-10.9
6	747.34	30.9 PK	46.0	-15.1	1.99 H	287	35.7	-4.8
7	830.95	26.2 PK	46.0	-19.8	1.99 H	160	29.8	-3.6
Antenna Polarity & Test Distance: Vertical At 3m								
No.	Freq. (MHz)	Emission Level (dBuV/m)	Limit (dBuV/m)	Margin (dB)	Antenna Height (m)	Table Angle (Degree)	Raw Value (dBuV)	Correction Factor (dB/m)
1	39.62	23.8 PK	40.0	-16.2	1.00 V	149	38.8	-15.0
2	107.90	37.7 PK	68.0	-30.3	1.00 V	41	55.1	-17.5
3	107.90	35.8 AV	48.0	-12.2	1.00 V	41	53.3	-17.5
4	108.00	36.6 QP	43.5	-6.9	1.00 V	60	54.0	-17.5
5	191.28	19.0 PK	43.5	-24.5	1.50 V	6	35.4	-16.4
6	424.59	22.8 PK	46.0	-23.2	1.49 V	179	33.3	-10.6
7	622.91	25.8 PK	46.0	-20.2	1.00 V	30	32.7	-6.9

Remarks:

1. Emission Level(dBuV/m) = Raw Value(dBuV) + Correction Factor(dB/m)
2. Correction Factor(dB/m) = Antenna Factor(dB/m) + Cable Factor(dB)
3. The other emission levels were very low against the limit.
4. Margin value = Emission Level – Limit value

EUT Test Condition		Measurement Detail	
Channel	Channel 1	Frequency Range	Below 1000MHz
Input Power	12Vdc	Detector Function	Peak (PK) Average (AV) Quasi-Peak (QP)
Environmental Conditions	22 deg. C, 66% RH	Tested By	Adair Peng
Sample No:	C180301-015-005-002		

Antenna Polarity & Test Distance: Horizontal At 3m								
No.	Freq. (MHz)	Emission Level (dBuV/m)	Limit (dBuV/m)	Margin (dB)	Antenna Height (m)	Table Angle (Degree)	Raw Value (dBuV)	Correction Factor (dB/m)
1	88.00	32.0 QP	40.0	-8.0	1.99 H	193	51.5	-19.5
2	88.10	41.2 PK	68.0	-26.8	1.99 H	195	60.7	-19.5
3	88.10	38.8 AV	48.0	-9.2	1.99 H	193	58.3	-19.5
4	132.95	27.4 PK	43.5	-16.1	1.99 H	270	42.6	-15.2
5	241.83	20.5 PK	46.0	-25.5	1.50 H	203	35.5	-15.0
6	545.14	27.2 PK	46.0	-18.8	1.99 H	305	36.0	-8.8
7	747.34	34.4 PK	46.0	-11.6	1.99 H	217	39.2	-4.8
Antenna Polarity & Test Distance: Vertical At 3m								
No.	Freq. (MHz)	Emission Level (dBuV/m)	Limit (dBuV/m)	Margin (dB)	Antenna Height (m)	Table Angle (Degree)	Raw Value (dBuV)	Correction Factor (dB/m)
1	39.62	24.9 PK	40.0	-15.1	1.00 V	3	39.9	-15.0
2	88.00	33.9 QP	40.0	-6.1	1.00 V	82	53.4	-19.5
3	88.10	41.1 PK	68.0	-26.9	1.00 V	75	60.6	-19.5
4	88.10	39.3 AV	48.0	-8.7	1.00 V	75	58.8	-19.5
5	241.83	19.9 PK	46.0	-26.1	1.00 V	15	34.9	-15.0
6	426.53	22.0 PK	46.0	-24.0	1.50 V	4	32.5	-10.5
7	642.35	24.5 PK	46.0	-21.5	1.00 V	124	31.2	-6.6

Remarks:

1. Emission Level(dBuV/m) = Raw Value(dBuV) + Correction Factor(dB/m)
2. Correction Factor(dB/m) = Antenna Factor(dB/m) + Cable Factor(dB)
3. The other emission levels were very low against the limit.
4. Margin value = Emission Level – Limit value

EUT Test Condition		Measurement Detail	
Channel	Channel 2	Frequency Range	Below 1000MHz
Input Power	12Vdc	Detector Function	Peak (PK) Average (AV) Quasi-Peak (QP)
Environmental Conditions	22 deg. C, 66% RH	Tested By	Adair Peng
Sample No:	C180301-015-005-002		

Antenna Polarity & Test Distance: Horizontal At 3m								
No.	Freq. (MHz)	Emission Level (dBuV/m)	Limit (dBuV/m)	Margin (dB)	Antenna Height (m)	Table Angle (Degree)	Raw Value (dBuV)	Correction Factor (dB/m)
1	57.12	27.5 PK	40.0	-12.5	1.99 H	357	41.8	-14.3
2	98.10	40.5 PK	68.0	-27.5	1.99 H	193	59.1	-18.6
3	98.10	35.8 AV	48.0	-12.2	1.99 H	192	54.4	-18.6
4	132.95	28.2 PK	43.5	-15.3	1.99 H	251	43.3	-15.2
5	296.27	19.4 PK	46.0	-26.6	1.50 H	16	32.2	-12.8
6	747.34	33.8 PK	46.0	-12.2	1.50 H	16	38.6	-4.8

Antenna Polarity & Test Distance: Vertical At 3m								
No.	Freq. (MHz)	Emission Level (dBuV/m)	Limit (dBuV/m)	Margin (dB)	Antenna Height (m)	Table Angle (Degree)	Raw Value (dBuV)	Correction Factor (dB/m)
1	98.10	38.5 PK	68.0	-29.5	1.00 V	66	57.1	-18.6
2	98.10	35.6 AV	48.0	-12.4	1.00 V	66	54.2	-18.6
3	241.83	20.2 PK	46.0	-25.8	1.00 V	181	35.2	-15.0
4	409.04	23.3 PK	46.0	-22.7	1.00 V	180	34.3	-11.1
5	603.47	26.2 PK	46.0	-19.8	1.00 V	28	33.4	-7.2
6	747.34	32.9 PK	46.0	-13.1	1.49 V	16	37.7	-4.8

Remarks:

1. Emission Level(dBuV/m) = Raw Value(dBuV) + Correction Factor(dB/m)
2. Correction Factor(dB/m) = Antenna Factor(dB/m) + Cable Factor(dB)
3. The other emission levels were very low against the limit.
4. Margin value = Emission Level – Limit value

EUT Test Condition		Measurement Detail	
Channel	Channel 3	Frequency Range	Below 1000MHz
Input Power	12Vdc	Detector Function	Peak (PK) Average (AV) Quasi-Peak (QP)
Environmental Conditions	22 deg. C, 66% RH	Tested By	Adair Peng
Sample No:	C180301-015-005-002		

Antenna Polarity & Test Distance: Horizontal At 3m								
No.	Freq. (MHz)	Emission Level (dBuV/m)	Limit (dBuV/m)	Margin (dB)	Antenna Height (m)	Table Angle (Degree)	Raw Value (dBuV)	Correction Factor (dB/m)
1	57.12	28.1 PK	40.0	-11.9	1.99 H	134	42.4	-14.3
2	107.90	36.0 PK	68.0	-32.0	1.50 H	203	53.4	-17.5
3	107.90	33.9 AV	48.0	-14.1	1.50 H	203	51.4	-17.5
4	108.00	36.1 QP	43.5	-7.4	1.50 H	198	53.5	-17.5
5	550.97	26.0 PK	46.0	-20.0	1.49 H	326	34.6	-8.7
6	729.49	33.7 QP	46.0	-12.3	1.12 H	53	38.9	-5.2
7	937.88	37.6 PK	46.0	-8.4	1.99 H	155	39.7	-2.0
Antenna Polarity & Test Distance: Vertical At 3m								
No.	Freq. (MHz)	Emission Level (dBuV/m)	Limit (dBuV/m)	Margin (dB)	Antenna Height (m)	Table Angle (Degree)	Raw Value (dBuV)	Correction Factor (dB/m)
1	107.90	35.6 PK	68.0	-32.4	1.00 V	57	53.0	-17.5
2	107.90	33.6 AV	48.0	-14.4	1.00 V	57	51.1	-17.5
3	108.00	35.5 QP	43.5	-8.0	1.00 V	67	53.0	-17.5
4	241.83	19.9 PK	46.0	-26.1	1.00 V	3	34.9	-15.0
5	510.14	24.7 PK	46.0	-21.3	1.00 V	169	33.8	-9.1
6	741.51	33.9 PK	46.0	-12.1	1.49 V	182	38.7	-4.9
7	935.94	37.1 PK	46.0	-8.9	1.49 V	1	39.1	-2.1

Remarks:

1. Emission Level(dBuV/m) = Raw Value(dBuV) + Correction Factor(dB/m)
2. Correction Factor(dB/m) = Antenna Factor(dB/m) + Cable Factor(dB)
3. The other emission levels were very low against the limit.
4. Margin value = Emission Level – Limit value

CHANNEL	TX Channel 1	DETECTOR FUNCTION	Peak (PK)
FREQUENCY RANGE	1GHz ~ 2GHz	DETECTOR FUNCTION	Average (AV)
Sample No:	C180103-029-012-010		

**ANTENNA POLARITY & TEST DISTANCE: HORIZONTAL AT 3 M**

NO.	FREQ. (MHz)	EMISSION LEVEL (dBuV/m)	LIMIT (dBuV/m)	MARGIN (dB)	ANTENNA HEIGHT (m)	TABLE ANGLE (Degree)	RAW VALUE (dBuV)	CORRECTION FACTOR (dB/m)
1	1145.30	34.00 PK	74.00	-40.00	1.71 H	122	41.00	-7.00
2	1145.30	21.70 AV	54.00	-32.30	1.71 H	122	28.70	-7.00

**ANTENNA POLARITY & TEST DISTANCE: VERTICAL AT 3 M**

NO.	FREQ. (MHz)	EMISSION LEVEL (dBuV/m)	LIMIT (dBuV/m)	MARGIN (dB)	ANTENNA HEIGHT (m)	TABLE ANGLE (Degree)	RAW VALUE (dBuV)	CORRECTION FACTOR (dB/m)
1	1145.30	33.80 PK	74.00	-40.20	1.09 V	297	40.80	-7.00
2	1145.30	21.80 AV	54.00	-32.20	1.09 V	297	28.80	-7.00

**REMARKS:**

1. Emission Level(dBuV/m) = Raw Value(dBuV) + Correction Factor(dB/m)
2. Correction Factor(dB/m) = Antenna Factor(dB/m) + Cable Factor(dB) – Pre-Amplifier Factor(dB)
3. The other emission levels were very low against the limit.
4. Margin value = Emission Level – Limit value

CHANNEL	TX Channel 2	DETECTOR FUNCTION	Peak (PK)
FREQUENCY RANGE	1GHz ~ 2GHz	DETECTOR FUNCTION	Average (AV)
Sample No:	C180103-029-012-010		

**ANTENNA POLARITY & TEST DISTANCE: HORIZONTAL AT 3 M**

NO.	FREQ. (MHz)	EMISSION LEVEL (dBuV/m)	LIMIT (dBuV/m)	MARGIN (dB)	ANTENNA HEIGHT (m)	TABLE ANGLE (Degree)	RAW VALUE (dBuV)	CORRECTION FACTOR (dB/m)
1	1177.20	34.60 PK	74.00	-39.40	1.66 H	131	41.50	-6.90
2	1177.20	22.00 AV	54.00	-32.00	1.66 H	131	28.90	-6.90

**ANTENNA POLARITY & TEST DISTANCE: VERTICAL AT 3 M**

NO.	FREQ. (MHz)	EMISSION LEVEL (dBuV/m)	LIMIT (dBuV/m)	MARGIN (dB)	ANTENNA HEIGHT (m)	TABLE ANGLE (Degree)	RAW VALUE (dBuV)	CORRECTION FACTOR (dB/m)
1	1177.20	35.30 PK	74.00	-38.70	1.19 V	331	42.20	-6.90
2	1177.20	22.10 AV	54.00	-31.90	1.19 V	331	29.00	-6.90

**REMARKS:**

1. Emission Level(dBuV/m) = Raw Value(dBuV) + Correction Factor(dB/m)
2. Correction Factor(dB/m) = Antenna Factor(dB/m) + Cable Factor(dB) – Pre-Amplifier Factor(dB)
3. The other emission levels were very low against the limit.
4. Margin value = Emission Level – Limit value

CHANNEL	TX Channel 3	DETECTOR FUNCTION	Peak (PK)
FREQUENCY RANGE	1GHz ~ 2GHz		Average (AV)
Sample No:	C180103-029-012-010		

**ANTENNA POLARITY & TEST DISTANCE: HORIZONTAL AT 3 M**

NO.	FREQ. (MHz)	EMISSION LEVEL (dBuV/m)	LIMIT (dBuV/m)	MARGIN (dB)	ANTENNA HEIGHT (m)	TABLE ANGLE (Degree)	RAW VALUE (dBuV)	CORRECTION FACTOR (dB/m)
1	1079.00	39.50 PK	74.00	-34.50	1.56 H	117	46.20	-6.70
2	1079.00	36.00 AV	54.00	-18.00	1.56 H	117	42.70	-6.70

**ANTENNA POLARITY & TEST DISTANCE: VERTICAL AT 3 M**

NO.	FREQ. (MHz)	EMISSION LEVEL (dBuV/m)	LIMIT (dBuV/m)	MARGIN (dB)	ANTENNA HEIGHT (m)	TABLE ANGLE (Degree)	RAW VALUE (dBuV)	CORRECTION FACTOR (dB/m)
1	1079.00	29.90 PK	74.00	-44.10	1.06 V	310	36.60	-6.70
2	1079.00	21.90 AV	54.00	-32.10	1.06 V	310	28.60	-6.70

**REMARKS:**

1. Emission Level(dBuV/m) = Raw Value(dBuV) + Correction Factor(dB/m)
2. Correction Factor(dB/m) = Antenna Factor(dB/m) + Cable Factor(dB) – Pre-Amplifier Factor(dB)
3. The other emission levels were very low against the limit.
4. Margin value = Emission Level – Limit value

## 4.2 Occupied Bandwidth Measurement

### 4.2.1 Limits of Occupied Bandwidth Measurement

Emissions from the intentional radiator shall be confined within bands 200kHz wide centered on the operating frequency. The 200 kHz band shall lie wholly within the frequency range of 88 to 108MHz.

### 4.2.2 Test Setup

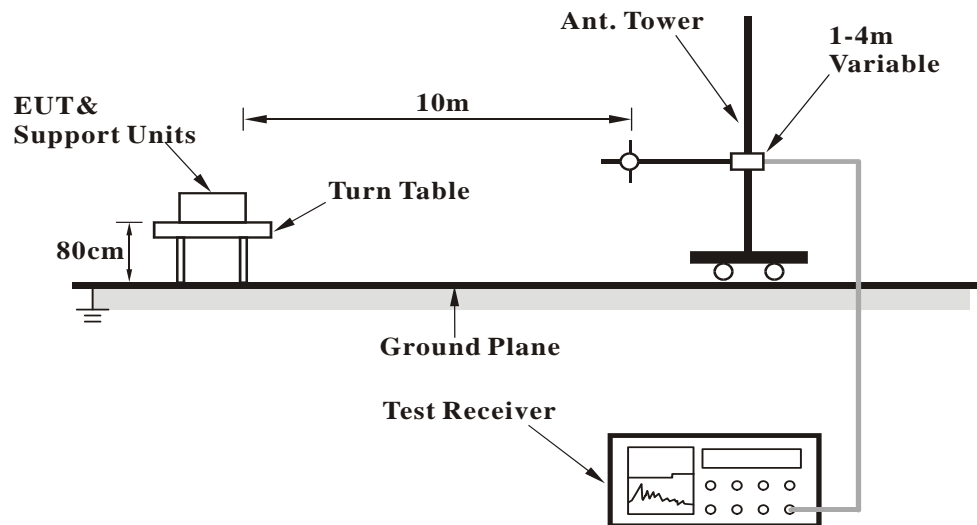

### 4.2.3 Test Instruments

Refer to section 4.1.2 to get information of above instrument.

### 4.2.4 Test Procedures

- The EUT was placed on the turn table.
- The signal was coupled to the spectrum analyzer through an antenna.
- Use the following spectrum analyzer settings for 20dB Bandwidth measurement. Span = approximately 2 to 3 times the 20 dB bandwidth, centered on a channel frequency; RBW=10 kHz; VBW=30 kHz, Sweep time = auto; Detector function = peak; Trace = maxhold.

### 4.2.5 Deviation from Test Standard

No deviation.

### 4.2.6 EUT Operating Conditions

The software provided by client to enable the EUT under transmission condition continuously at lowest, middle and highest channel frequencies individually.

### 4.2.7 Test Results

Sample No: C180103-029-012-003

Channel Number	Freq. (MHz)	20dB Bandwidth (MHz)	Measured frequencies		Limit		Pass /Fail
			FL (MHz)	FH (MHz)	FL~FH (MHz)	Bandwidth(kHz)	
1	88.1	0.0750	88.064	88.139	88~108	200.00	Pass
2	98.1	0.0750	98.062	98.137	88~108	200.00	Pass
3	107.9	0.0810	107.864	107.945	88~108	200.00	Pass

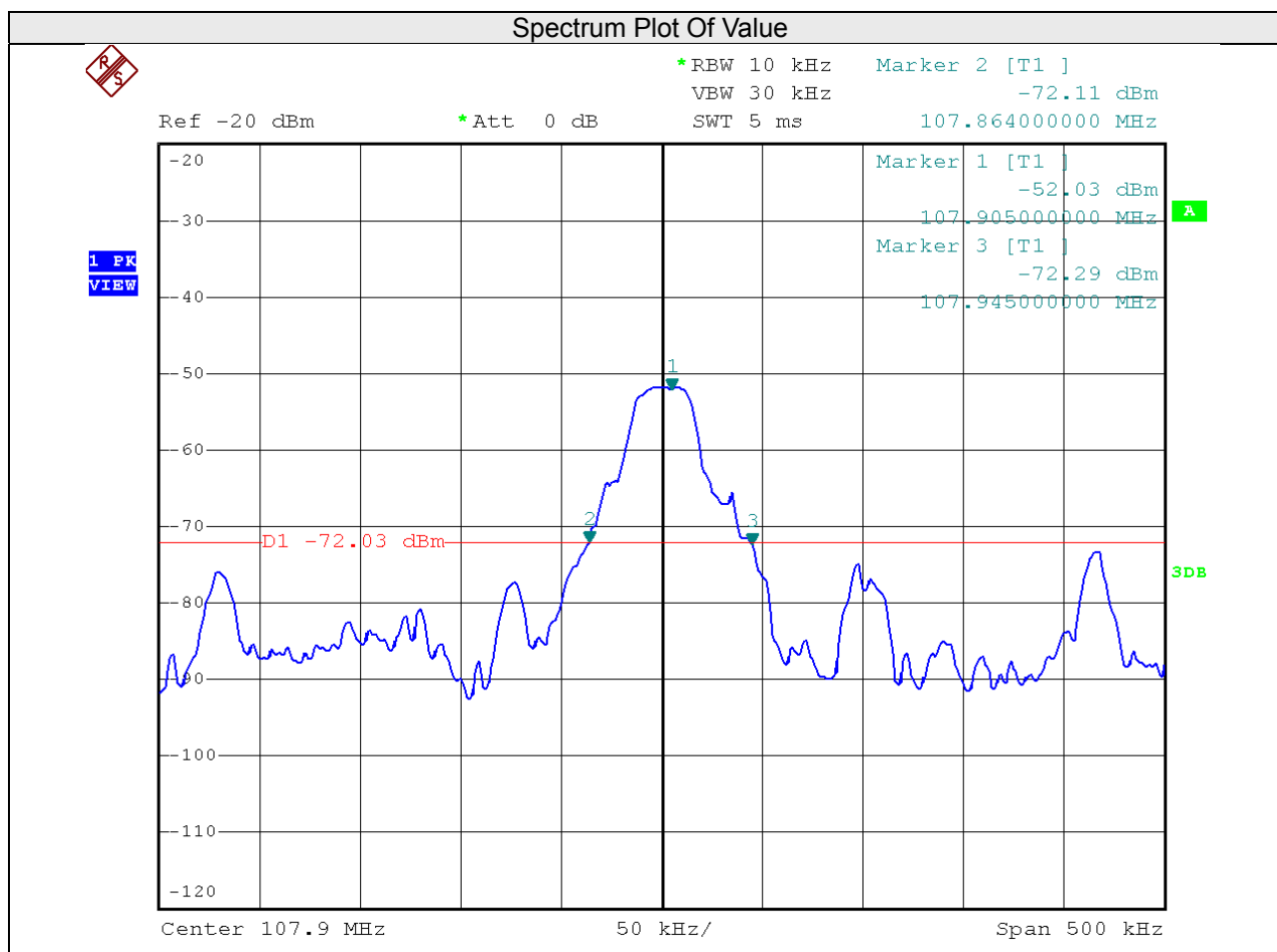



## 5 Pictures of Test Arrangements

Please refer to the attached file (Test Setup Photo).

## Appendix – Information on the Testing Laboratories

We, Bureau Veritas Consumer Products Services (H.K.) Ltd., Taoyuan Branch, were founded in 1988 to provide our best service in EMC, Radio, Telecom and Safety consultation. Our laboratories are accredited and approved according to ISO/IEC 17025.

If you have any comments, please feel free to contact us at the following:

### Linko EMC/RF Lab

Tel: 886-2-26052180

Fax: 886-2-26051924

### Hsin Chu EMC/RF/Telecom Lab

Tel: 886-3-6668565

Fax: 886-3-6668323

### Hwa Ya EMC/RF/Safety Lab

Tel: 886-3-3183232

Fax: 886-3-3270892

**Email:** [service.adt@tw.bureauveritas.com](mailto:service.adt@tw.bureauveritas.com)

**Web Site:** [www.bureauveritas-adt.com](http://www.bureauveritas-adt.com)

The address and road map of all our labs can be found in our web site also.

--- END ---