



FCC TEST REPORT

CATEGORY: Mobile End Product
PRODUCT NAME: Bluetooth Audio Adapter
FCC ID.: K7SF8T060xDNGL
FILING TYPE: Certification
BRAND NAME: BELKIN
MODEL NAME: F8T060xDNGL

APPLICANT: **BELKIN CORPORATION**
501 West Walnut Street Compton CA 90220-5221

MANUFACTURER: The same as Applicant.

ISSUED BY: **SPORTON INTERNATIONAL INC.**
6F, No. 106, Sec. 1, Hsin Tai Wu Rd., His Chih, Taipei Hsien,
Taiwan, R.O.C.

Statements:

The test result in this report refers exclusively to the presented test model / sample.

Without written approval of SPORTON International Inc., the test report shall not be reproduced except in full.

Certificate or Test Report could not be used by the applicant to claim the product endorsement by CNLA, NVLAP or any agency of U.S. government.

The test equipment used to perform the test are calibrated and traceable to NML/ROC or NIST/USA.

Dr. Alan Lane
Vice General Manager
Sporton International Inc.

Lab Code: 200079-0



Table of Contents

History of this test report.....ii

1. General Description of Equipment under Test..... 1

 1.1. Applicant..... 1

 1.2. Manufacturer 1

 1.3. Basic Description of Equipment under Test 1

 1.4. Technical Features..... 1

 1.5. Table for Carrier Frequencies 2

2. Test Configuration of the Equipment under Test..... 3

 2.1. Description of the Test 3

 2.2. Frequency Range Investigated 3

 2.3. Details of the Supporting Units..... 3

 2.4. Connection Diagram of Test System 4

 2.5. Test Software 4

3. Test Location and Standards 5

 3.1. Test Location..... 5

 3.2. Test Conditions 5

 3.3. Test Standards..... 5

 3.4. DoC Statement..... 5

4. Test Result and Details 6

 4.1. Summary of the Test Results 6

5. Test Result 7

 5.1. Test of Hopping Channel Bandwidth..... 7

 5.2. Test of Number of Hopping Frequency 10

 5.3. Test of Hopping Channel Separation 12

 5.4. Test of Dwell Time of Each Frequency within a 31.6 Seconds Period..... 15

 5.5. Test of Maximum Peak Output Power 18

 5.6. Test of Band Edges of the Operation Frequency 21

 5.7. Test of AC Power Line Conducted Emission 24

 5.8. Test of Spurious Radiated Emission 27

 5.9. Antenna Requirements 35

 5.10. RF Exposure 36

6. List of Measuring Equipments Used 38

Appendix A. Photographs of EUT..... A1 ~ A8



1. General Description of Equipment under Test

1.1. Applicant

BELKIN CORPORATION

501 West Walnut Street Compton CA 90220-5221

1.2. Manufacturer

The same as Applicant.

1.3. Basic Description of Equipment under Test

This product is a Bluetooth Adapter. The technical data has been listed on section below. This adapter is used to connect with the audio output port, through the wireless bluetooth technology, the audio signal can be transmitted to the receiver with bluetooth solution. A cradle for charge purpose is also provided.

1.4. Technical Features

ITEM	DESCRIPTION
Type of Modulation	FHSS (GFSK)
Number of Channels	79
Frequency Band	2400MHz ~ 2483.5MHz
Carrier Frequency of Each Channel	Please reference table below.
Channel Bandwidth	1MHz
Output Power	0.03dBm (peak)
Antenna Type / Gain	Ceramic Antenna / 0dBi
Function Type	Transceiver
Power Rating (DC/AC , Voltage)	5 VDC
Temperature Range (Operating)	-10 ~ 50°C



1.5. Table for Carrier Frequencies

Note: The table below is the summary of the operating frequencies.

Channel	Frequency	Channel	Frequency	Channel	Frequency
00	2402 MHz	27	2429 MHz	54	2456 MHz
01	2403 MHz	28	2430 MHz	55	2457 MHz
02	2404 MHz	29	2431 MHz	56	2458 MHz
03	2405 MHz	30	2432 MHz	57	2459 MHz
04	2406 MHz	31	2433 MHz	58	2460 MHz
05	2407 MHz	32	2434 MHz	59	2461 MHz
06	2408 MHz	33	2435 MHz	60	2462 MHz
07	2409 MHz	34	2436 MHz	61	2463 MHz
08	2410 MHz	35	2437 MHz	62	2464 MHz
09	2411 MHz	36	2438 MHz	63	2465 MHz
10	2412 MHz	37	2439 MHz	64	2466 MHz
11	2413 MHz	38	2440 MHz	65	2467 MHz
12	2414 MHz	39	2441 MHz	66	2468 MHz
13	2415 MHz	40	2442 MHz	67	2469 MHz
14	2416 MHz	41	2443 MHz	68	2470 MHz
15	2417 MHz	42	2444 MHz	69	2471 MHz
16	2418 MHz	43	2445 MHz	70	2472 MHz
17	2419 MHz	44	2446 MHz	71	2473 MHz
18	2420 MHz	45	2447 MHz	72	2474 MHz
19	2421 MHz	46	2448 MHz	73	2475 MHz
20	2422 MHz	47	2449 MHz	74	2476 MHz
21	2423 MHz	48	2450 MHz	75	2477 MHz
22	2424 MHz	49	2451 MHz	76	2478 MHz
23	2425 MHz	50	2452 MHz	77	2479 MHz
24	2426 MHz	51	2453 MHz	78	2480 MHz
25	2427 MHz	52	2454 MHz		
26	2428 MHz	53	2455 MHz		



2. Test Configuration of the Equipment under Test

2.1. Description of the Test

- a) This test report is only for the BlueTooth part of the product.
- b) For 15.247(g), during data transmission, the carrier frequency is repeatedly switched on 79 hopping frequencies, any 2 hopping frequencies will not be available on the spectrum simultaneously. So, this device can be taken as true frequency hopping device.
- c) For 15.247(h), the hopping sequence is determined by the address of piconet master. Each piconet master will have its unique address at any moment, so re-use of the hopping sequence is completely not possible. Within the piconet, one master can be communicated with many slaves via the same hopping sequence, but at any moment only one (master or slave) can be "talk". It is determined by the master that who should be "listen" or "talk". Any slave who want to "talk" has to sent "inquiry" to master first. So, 2 slaves (or one slave one master) is not possible to be on "talk" mode simultaneously.
- d) The used peripherals as well as the configuration fulfill the requirements of ANSI C63.4:2001. The configuration is operated in a manner which tends to maximize its emission characteristics in a typical application.
- e) The following modes were tested:
 - Mode 1: CH 00 (2402 MHz)
 - Mode 2: CH 39 (2441 MHz)
 - Mode 3: CH 78 (2480 MHz)
- f) 3 meters measurement distance of OATS was used in this test.

2.2. Frequency Range Investigated

- a) Conducted power line test: from 150 kHz to 30 MHz
- b) Radiated emission test: from 30 MHz to 25000 MHz

2.3. Details of the Supporting Units

The EUT was tested with a set of mobile phone.

2.4. Connection Diagram of Test System

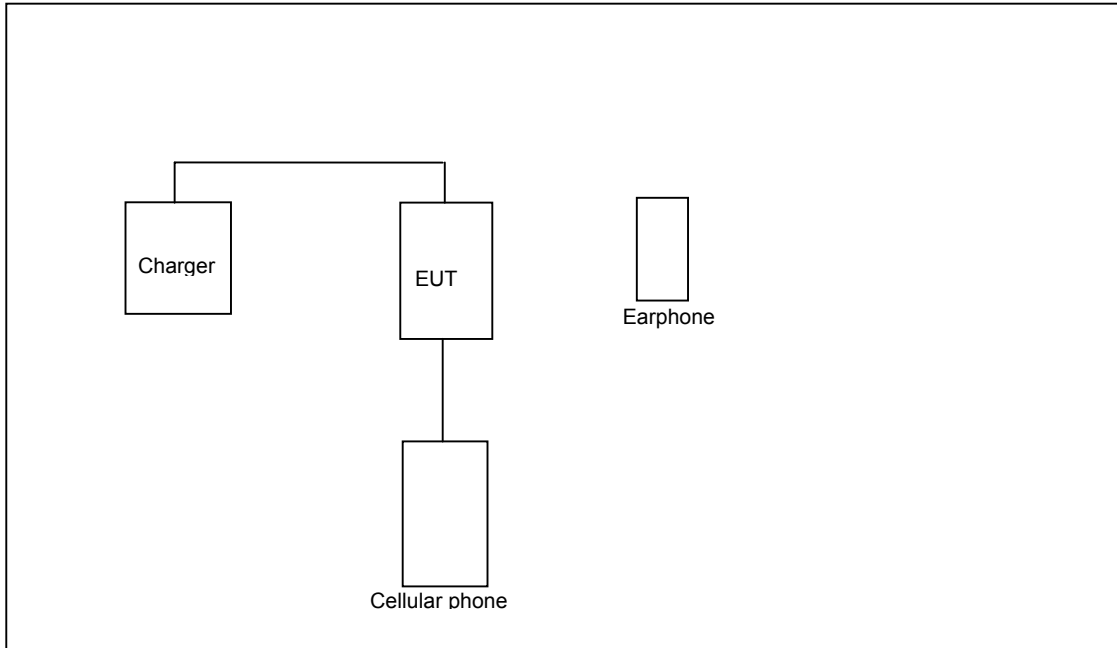

2.5. Test Software

A software and a testing controlling feature was provided to control this device. There is an RS232 port on the controlling feature which can be connected with the notebook computer. There are also wires in this controlling feature can be used to control the bluetooth IC in the EUT for channel selection or power control purpose.



3. Test Location and Standards

3.1. Test Location

Test Location : Sporton Hwa Ya Testing Building

Address : No. 52, Hwa Ya 1st Rd., Hwa Ya Technology Park, Kwei-Shan Hsiang, Tao Yuan Hsien, Taiwan, R.O.C.

Tel: +886 3 327 3456 Fax: +886 3 318 0055

Test Site No. : CO01-HY , 03CH03-HY

3.2. Test Conditions

Normal Voltage : 120V/60Hz

Extreme Voltages : 138V and 102V

Normal Temperature : 20 °C

Extreme Temperature : -20 °C and 50 °C

3.3. Test Standards

Here is the list of the standards followed in this test report.

ANSI C63.4-2001

47 CFR Part 15 Subpart C (Section 15.247)

3.4. DoC Statement

This EUT is also classified as a device of computer peripheral Class B which DoC has to be followed. It has been verified according to the rule of 47 CFR part 15 Subpart B, and found that all the requirements has been fulfilled.



4. Test Result and Details

4.1. Summary of the Test Results

Applied Standard: 47 CFR Part 15 and Part 2			
Paragraph	FCC Rule	Description of Test	Result
5.1	15.247(a)(1)	Hopping Channel Bandwidth	Pass
5.2	15.247(a)(iii)	Number of Hopping Frequency Used	Pass
5.3	15.247(a)(1)	Hopping Channel Separation	Pass
5.4	15.247(a)(iii)	Dwell Time of Each Frequency within a 31.6 Second Period	Pass
5.5	15.247 (b)(1)	Maximum Peak Output Power	Pass
5.6	15.247(c)	Band Edges of the Operation Frequency	Pass
5.7	15.247(d)	Power Spectral Density	Pass
5.8	15.107/15.207	AC Power Line Conducted Emission	Pass
5.9	15.209/15.247(c)	Spurious Radiated Emission	Pass
5.10	15.203	Antenna Requirement	Pass
5.11	2.1091/2.1093	Maximum Permissible Exposure for the EUT	Pass

5. Test Result

5.1. Test of Hopping Channel Bandwidth

5.1.1. Measuring Instruments

Item 9 of the table on section 6.

5.1.2. Test Procedures

1. The transmitter output was connected to the spectrum analyzer through an attenuator.
2. Set RBW of spectrum analyzer to 30KHz and VBW to 300KHz.
3. The Hopping Channel bandwidth is defined as the total spectrum the power of which is higher than peak power minus 20 dB.

5.1.3. Test Setup Layout

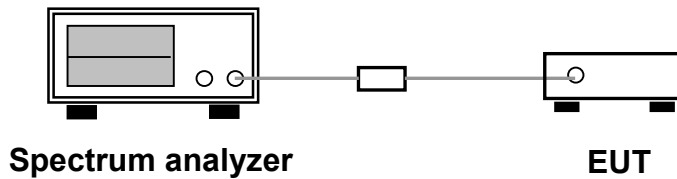

5.1.4. Test Result : See spectrum analyzer plots below

- Operating Mode: Continuously Transmitting
- Temperature: 24°C
- Relative Humidity: 52 %
- Duty Cycle of the Equipment During the Test: 100%
- Test Engineer: Murray Lu

Channel	Frequency (MHz)	Hopping Channel Bandwidth (KHz)
00	2402	924.000
39	2441	920.000
78	2480	916.000



(Channel 00) :

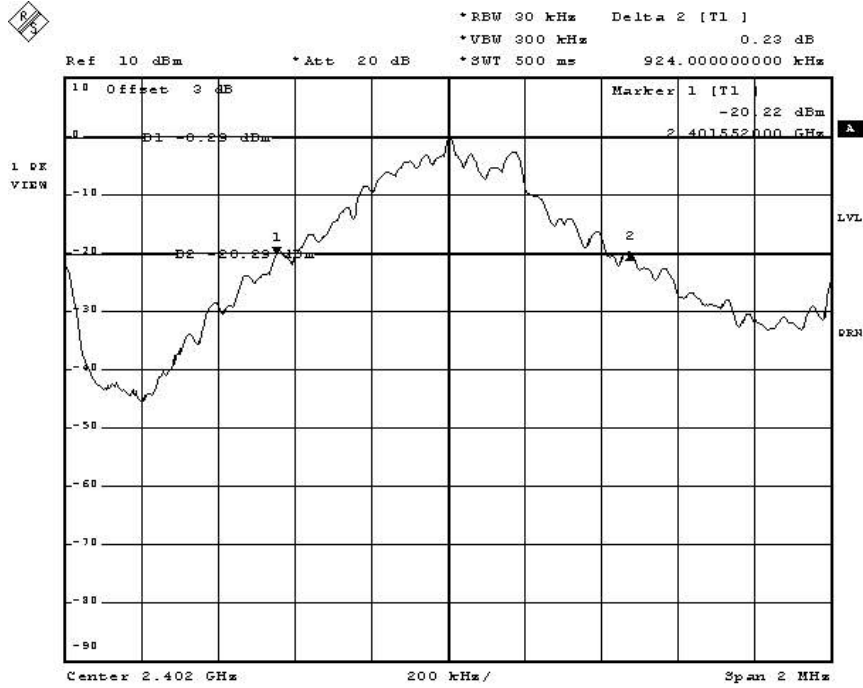

Date: 30. APR. 2004 22:01:48

(Channel 39) :

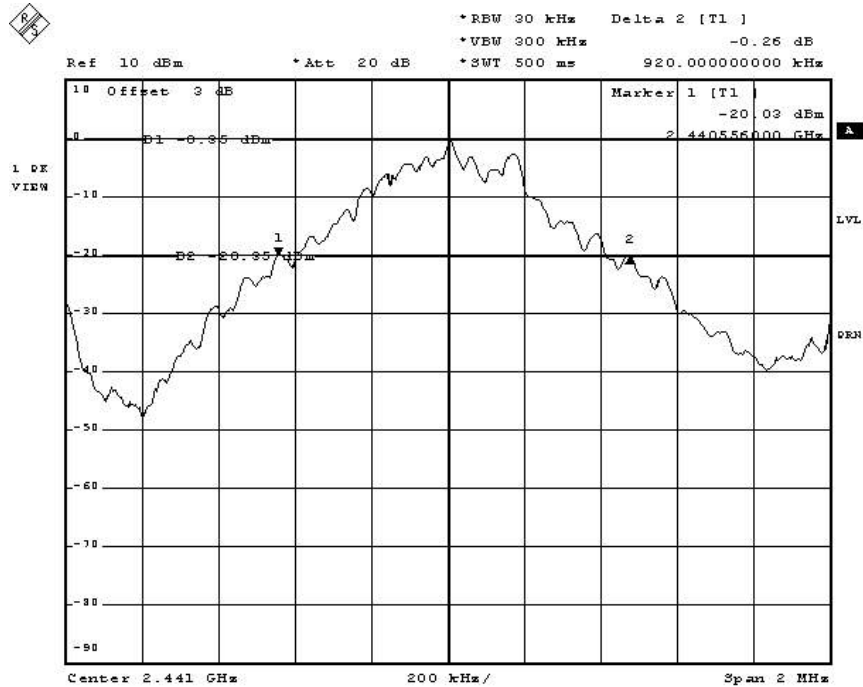

Date: 30. APR. 2004 22:17:45



(Channel 78) :

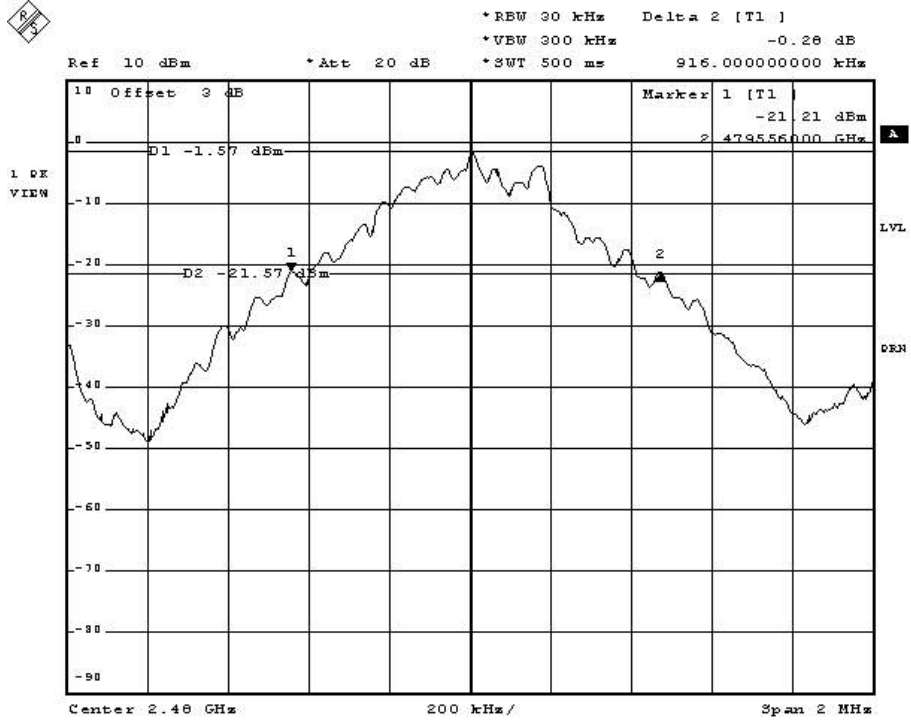

Date: 30.APR.2004 21:59:56

5.2. Test of Number of Hopping Frequency

5.2.1. Measuring Instruments

Item 9 of the table on section 6.

5.2.2. Test Procedures

1. The transmitter output was connected to the spectrum analyzer through an attenuator.
2. Set RBW of spectrum analyzer to 100KHz and VBW to 100KHz.
3. The number of hopping frequency used is defined as the total number of the channels available on the spectrum.

5.2.3. Test Setup Layout

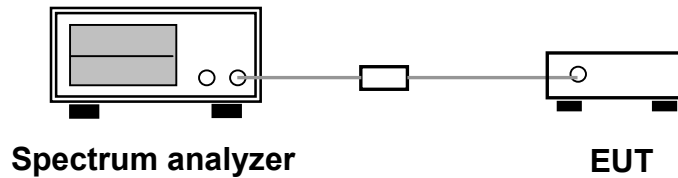

5.2.4. Test Result : See spectrum analyzer plots below

- Operating Mode: Normal Hopping
- Temperature: 24°C
- Relative Humidity: 52 %
- Duty Cycle of the Equipment During the Test: 100%
- Test Engineer: Murray Lu

Number of Hopping Frequencies	Limit
79	75

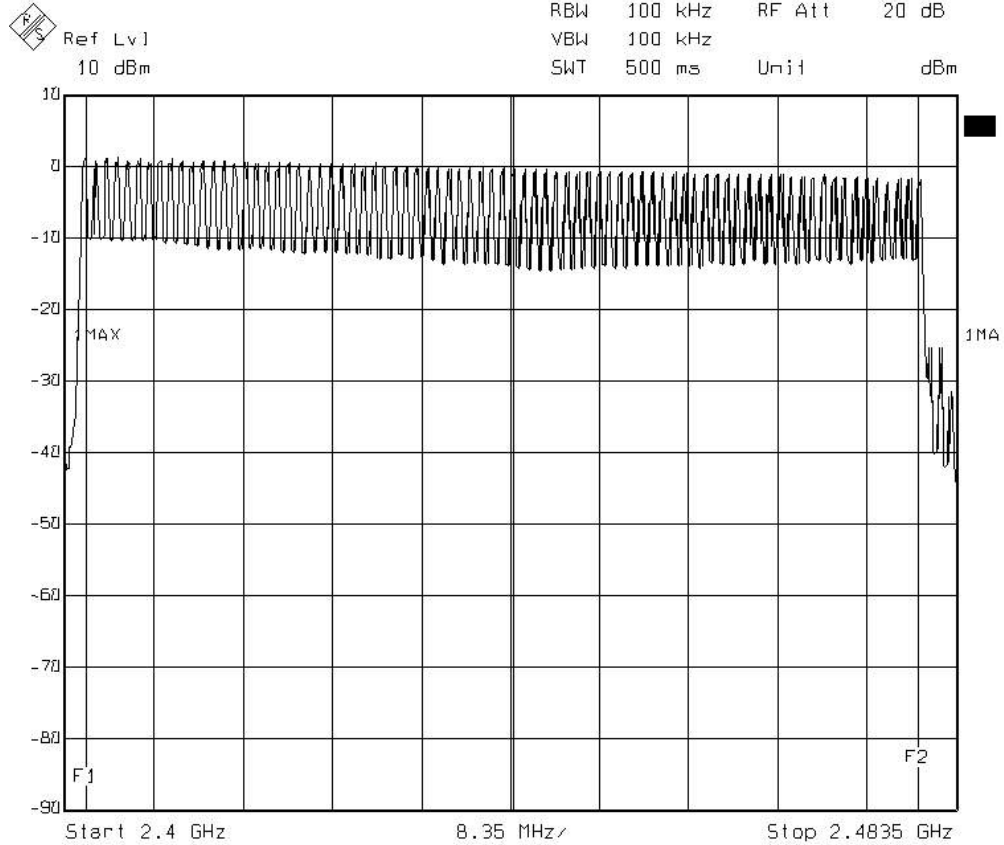

Date: 17.MAY 2004 09:25:18

5.3. Test of Hopping Channel Separation

5.3.1. Measuring Instruments

Item 9 of the table on section 6.

5.3.2. Test Procedures

1. The transmitter output was connected to the spectrum analyzer through an attenuator.
2. Set RBW of spectrum analyzer to 30KHz and VBW to 100KHz.
3. The Hopping Channel Separation is defined as the separation between 2 neighboring hopping frequencies.

5.3.3. Test Setup Layout

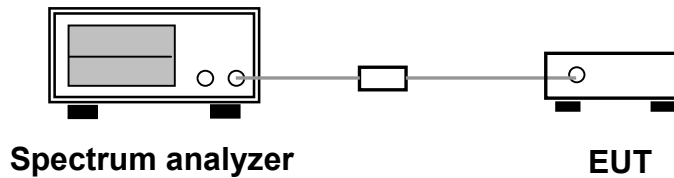

5.3.4. Test Result : The spectrum analyzer plots are attached as below

- Operating Mode: Normal Hopping
- Temperature: 24°C
- Relative Humidity: 52 %
- Duty Cycle of the Equipment During the Test: 100%
- Test Engineer: Murray Lu

Channel	Frequency (MHz)	Hopping Channel Separation (KHz)	Limits (KHz)
00	2402	1000.0000	924.00
39	2441	1000.0000	920.00
78	2480	1000.0000	916.00

Note: The limit is the min of 25KHz or 20dB bandwidth , which is greater.



(Channel 00) :

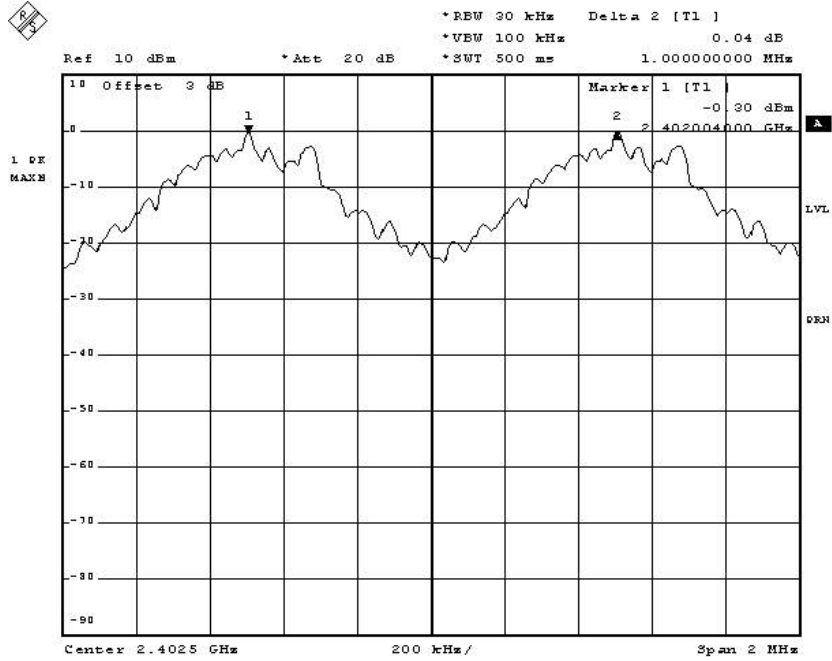

Date: 30.APR.2004 22:07:22

(Channel 39) :

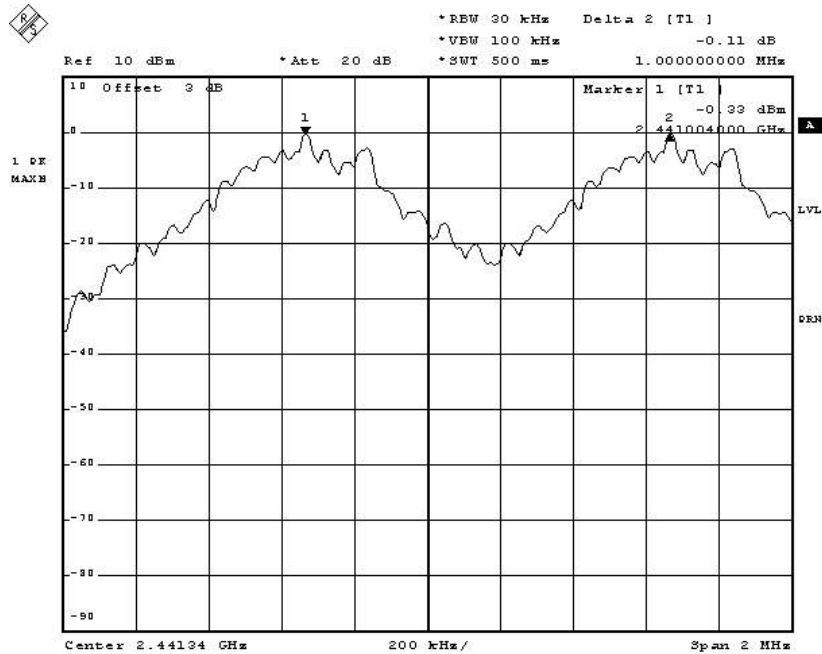

Date: 30.APR.2004 22:14:30



(Channel 78) :

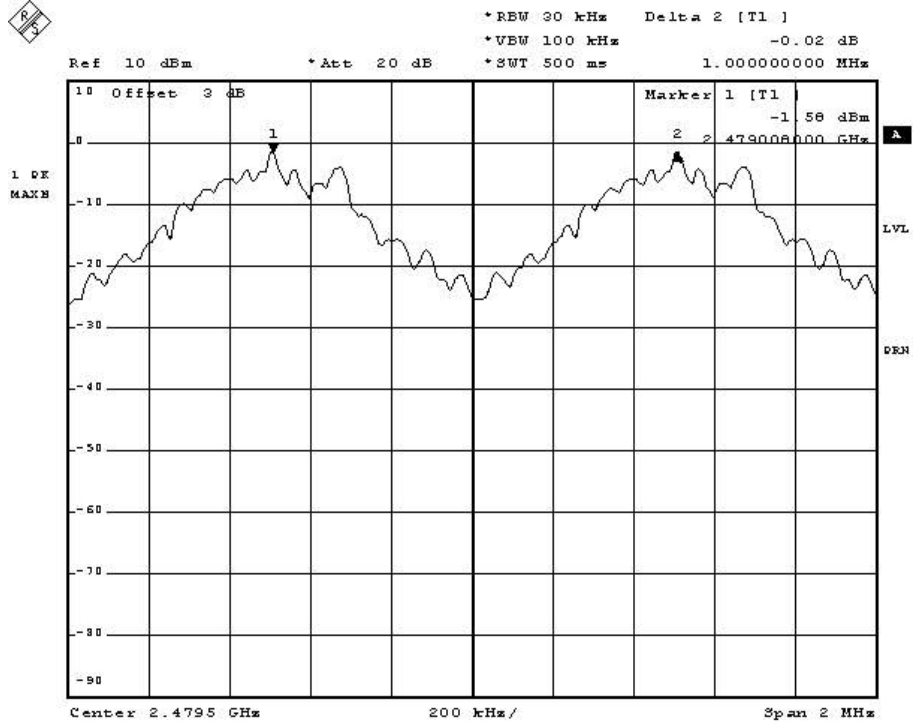

Date: 30.APR.2004 22:15:15

5.4. Test of Dwell Time of Each Frequency within a 31.6 Seconds Period

5.4.1. Measuring Instruments

Item 9 of the table on section 6.

5.4.2. Test Procedures

1. The transmitter output was connected to the spectrum analyzer through an attenuator.
2. Set RBW of spectrum analyzer to 100kHz and VBW to 100kHz.
3. Set the center frequency on any frequency would be measure and set the frequency span to zero span.
4. Set the EUT for DH5 packet transmitting.
5. Measure the maximum time duration, t , of one single pulse.
6. DH5 Packet permit maximum 320 hops per second in 79 channels. So, the dwell time is the time duration of the pulse times 128 within 31.6 seconds.

5.4.3. Test Setup Layout

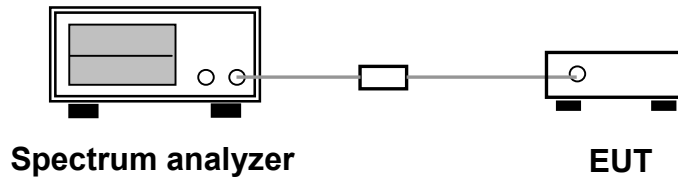

5.4.4. Test Result : See spectrum analyzer plots below

- Operating Mode: Normal Hopping
- Temperature: 24°C
- Relative Humidity: 52 %
- Duty Cycle of the Equipment During the Test : 100%
- Test Engineer: Murray Lu

Channel	Frequency (MHz)	Pulse Duration (ms)	Dwell Time (s)	Limits (s)
00	2402	2.98	0.38144	0.4
39	2441	2.98	0.38144	0.4
78	2480	2.98	0.38144	0.4



(Channel 00) :

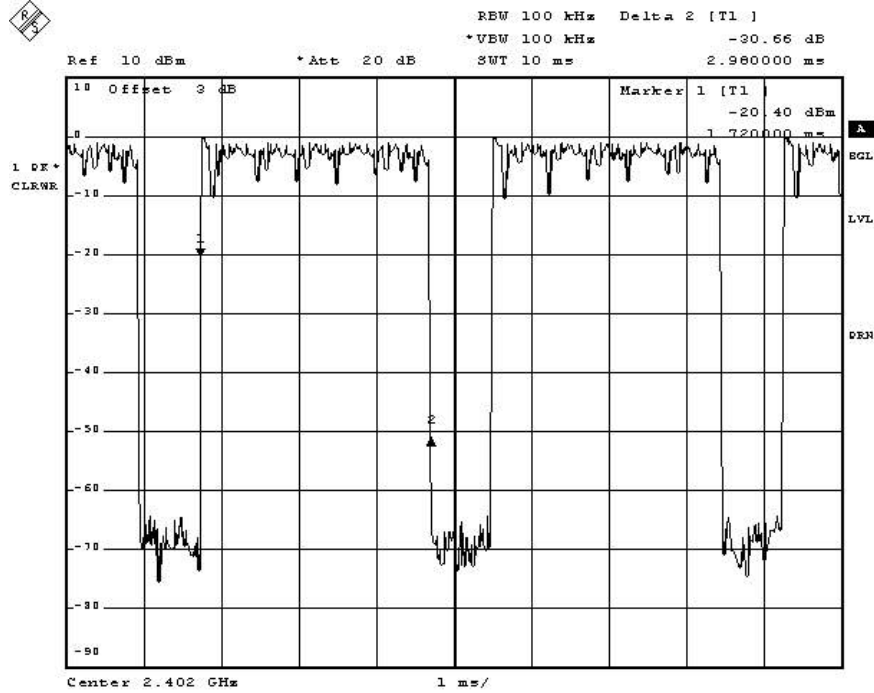

Date: 30.APR.2004 22:20:10

(Channel 39) :

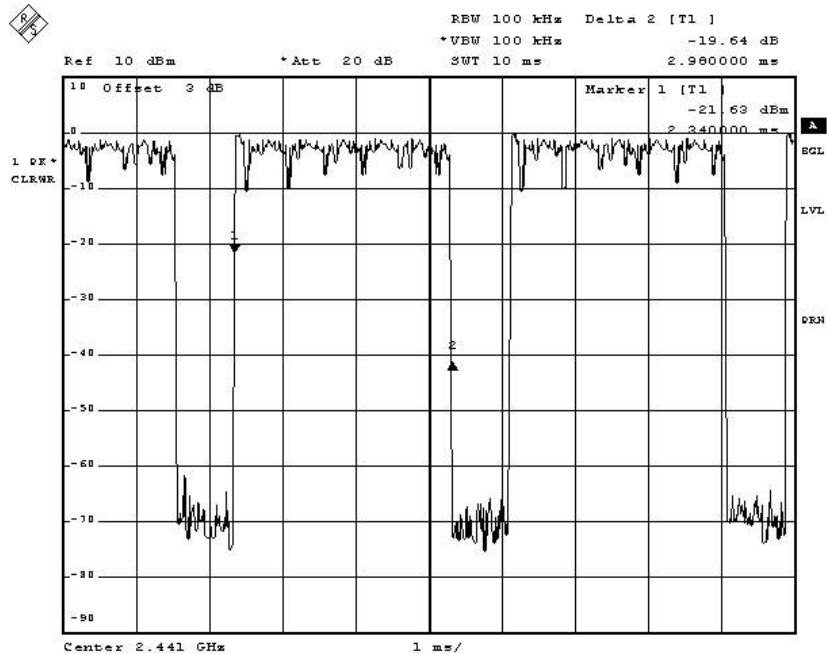

Date: 30.APR.2004 22:21:17



(Channel 78) :

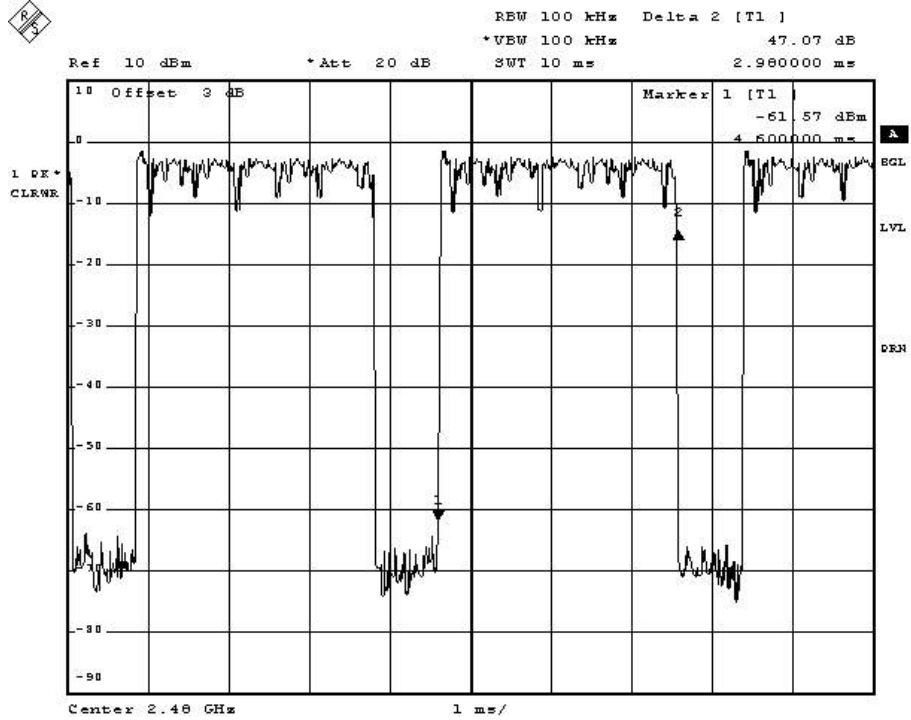

Date: 30.APR.2004 22:22:03

5.5. Test of Maximum Peak Output Power

5.5.1. Measuring Instruments

Item 9 of the table on section 6.

5.5.2. Test Procedures

1. The transmitter output was connected to the spectrum analyzer through an attenuator.
2. The center frequency of the spectrum analyzer was set to the fundamental frequency
3. Adjust RBW to 3MHz and VBW to 3MHz.

5.5.3. Test Setup Layout

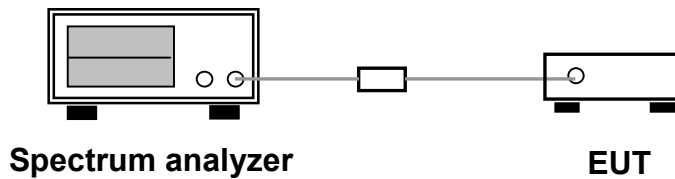

5.5.4. Test Result : See spectrum analyzer plots below

- Operating Mode: single channel continuous transmitting
- Temperature: 24°C
- Relative Humidity: 52 %
- Duty cycle of the equipment during the test : 100%
- Test Engineer: Murray Lu

Channel	Frequency (MHz)	Measured Output Power (dBm)	Measured Output Power (mWatt)	Limits (Watt/dBm)
00	2402	0.03	1.00693	1W/30dBm
39	2441	-0.11	0.97499	1W/30dBm
78	2480	-1.25	0.74989	1W/30dBm



(Channel 00) :

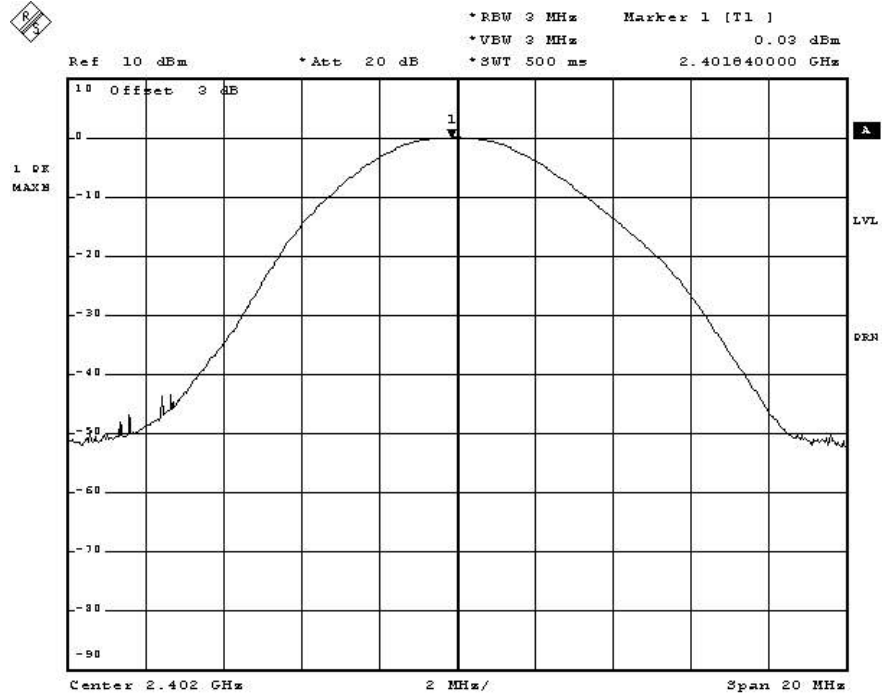

Date: 30.APR.2004 21:53:36

(Channel 39) :

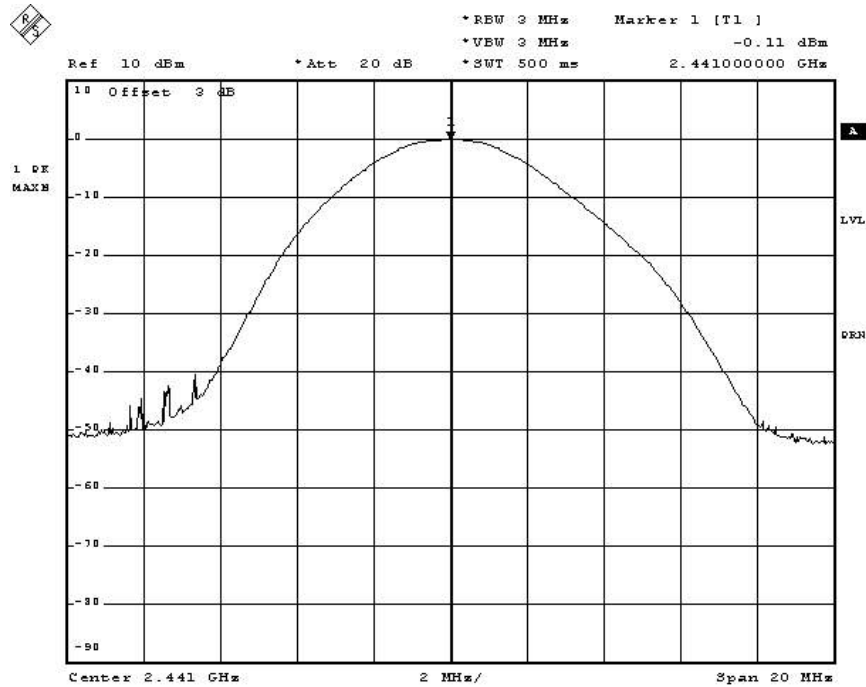

Date: 30.APR.2004 22:16:30



(Channel 78) :

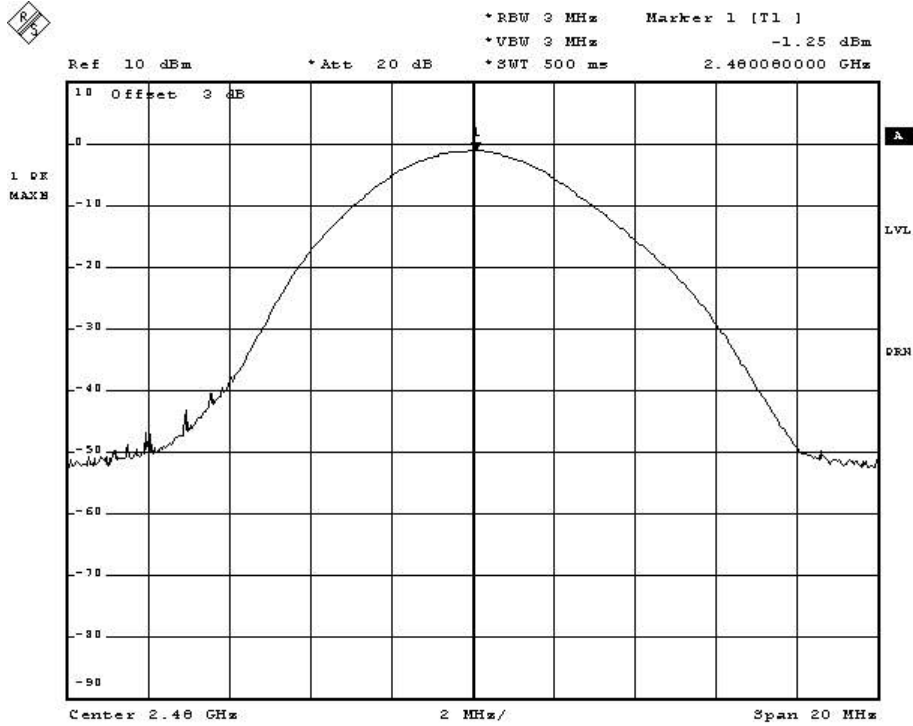

Date: 30.APR.2004 21:57:07



5.6. Test of Band Edges of the Operation Frequency

5.6.1. Measuring Instruments

Item 9 of the table on section 6.

5.6.2. Test Procedures

1. The transmitter output was connected to the spectrum analyzer via a low lose cable.
2. Set both RBW and VBW of spectrum analyzer to 100KHz with convenient frequency span including 100 KHz bandwidth from band edge.
3. The band edges emission was measured and recorded.

5.6.3.

Test Result in lower band (Channel 00) : PASS
 Test Result in higher band(Channel 78) : PASS

5.6.4. Note on Band edge Emission

(A) Left Edge

The band edge emission plot shows 50.02dB delta between carrier maximum power and local maximum emission in the restricted band.

CH 00 Carrier power strength (dB μ V/m)	Delta (dB)	The maximum field strength in restrict band (dB μ V/m)	Limit (dB μ V/m)	Margin (dB)
67.85	50.02	17.83	54.00	-36.17

(B) Right Edge

The band edge emission plot shows 52.13dB delta between carrier maximum power and local maximum emission in the restricted band.

CH 78 Carrier power strength (dB μ V/m)	Delta (dB)	The maximum field strength in restrict band (dB μ V/m)	Limit (dB μ V/m)	Margin (dB)
67.57	52.13	15.44	54.00	-38.56

* The maximum field strength in restricted band is the emission of carrier power strength subtract to the delta between carrier maximum power and local maximum emission in the restricted band.



(Channel 00) :

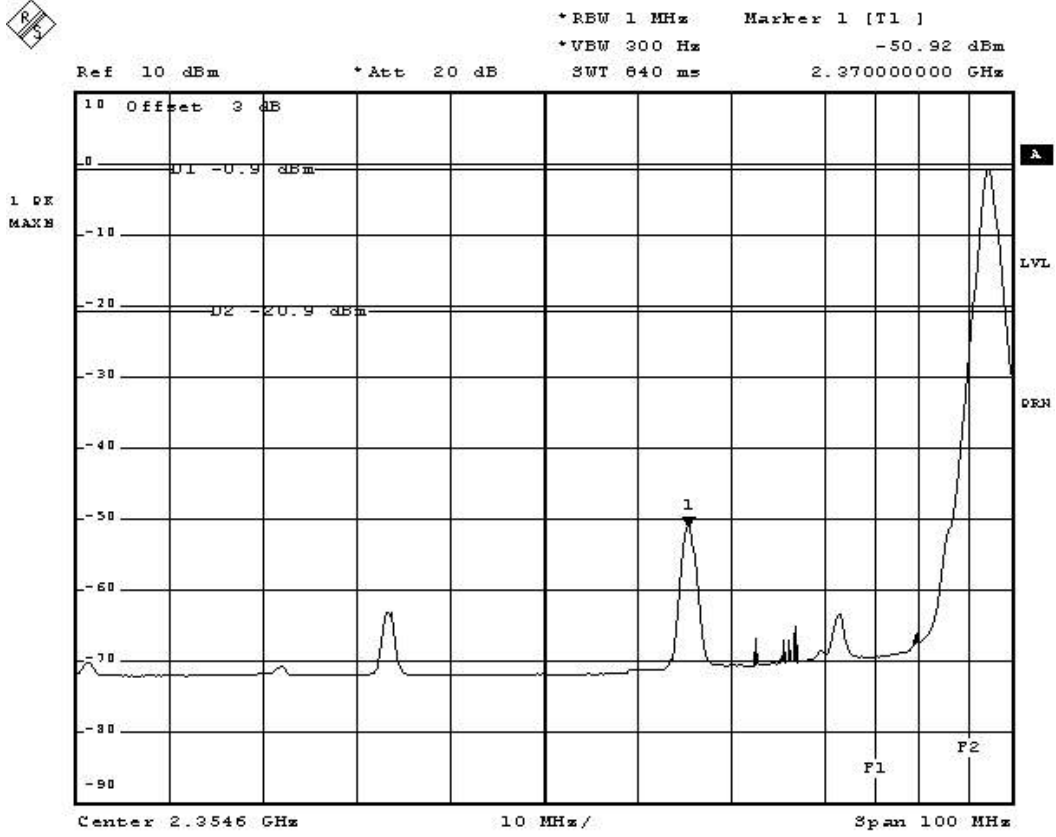

Date: 30. APR. 2004 22:35:02



(Channel 78) :

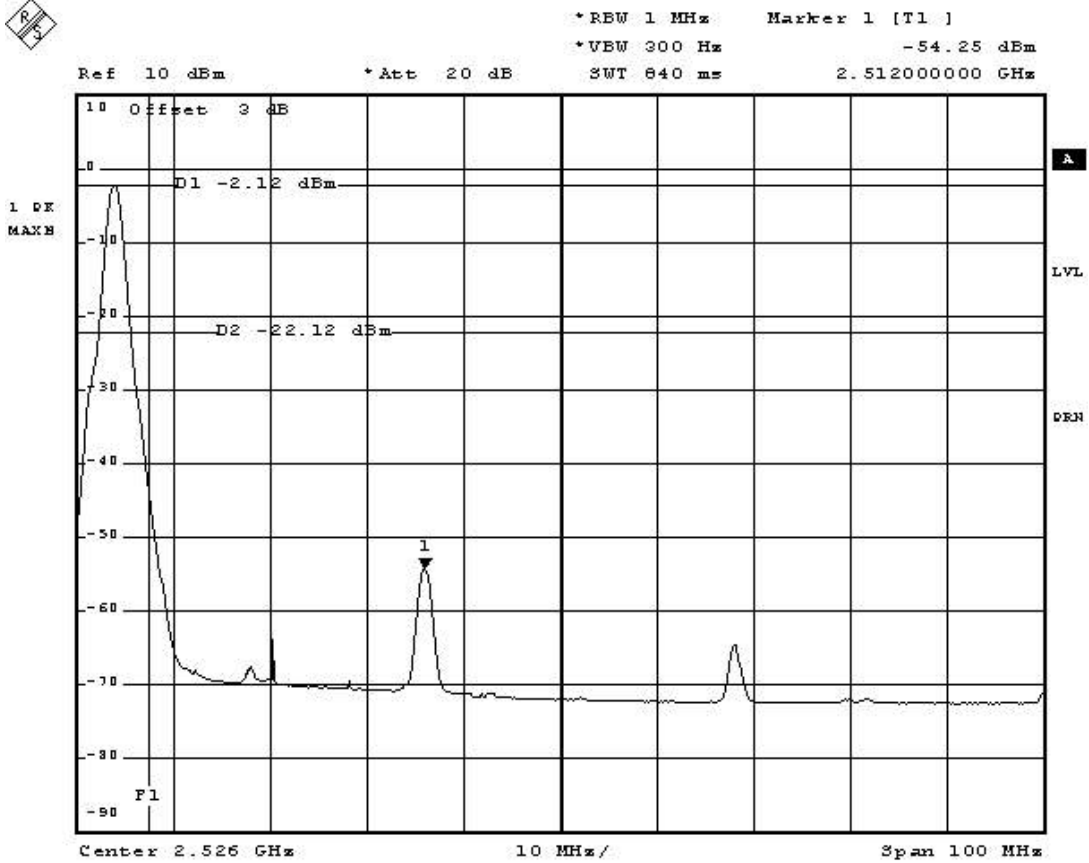

Date: 30.APR.2004 22:25:58

Observation : All emissions in the 100kHz band edge are all lower than carrier by more than 20dB.



5.7. Test of AC Power Line Conducted Emission

5.7.1. Measuring Instruments

Please reference item 1~7 in chapter 6 for the instruments used for testing.

5.7.2. Test Procedures

1. Configure the EUT according to ANSI C63.4.
2. The EUT has to be placed 0.4 meter far from the conducting wall of the shielding room and at least 80 centimeters from any other grounded conducting surface.
3. Connect EUT to the power mains through a line impedance stabilization network (LISN).
4. All the support units are connected to the other LISNs. The LISN should provides 50uH/50ohms coupling impedance.
5. The frequency range from 150 KHz to 30 MHz was searched.
6. Use the Channel & Power Controlling software to make the EUT working on selected channel and expected output power, then use the "H" Patter Generator software to make the supporting equipments stay on working condition.
7. Set the test-receiver system to Peak Detect Function and Specified Bandwidth with Maximum Hold Mode.
8. The measurement has to be done between each power line and ground at the power terminal for each RF channel. Only one RF channel has to be investigated since this test is independent with the RF channel selection.



5.7.3. Test Result of Conducted Emission

Test Mode	RF LINK	Tested By	Brian Lin
Temperature / Humidity	24deg. C / 52%		

Line to Ground

	Freq	Level	Over Limit	Limit Line	Read Level	LISN Factor	Cable Loss	Remark
	MHz	dBuV	dB	dBuV	dBuV	dB	dB	
1	@0.1540270	23.52	-42.26	65.78	23.41	0.10	0.01	QP
2	@0.1540270	11.35	-44.43	55.78	11.24	0.10	0.01	Average
3	@0.1767760	8.23	-46.41	54.64	8.12	0.10	0.01	Average
4	@0.1767760	22.44	-42.20	64.64	22.33	0.10	0.01	QP
5	@0.2391010	19.65	-42.48	62.13	19.54	0.10	0.01	QP
6	@0.2391010	18.70	-33.43	52.13	18.59	0.10	0.01	Average
7	@0.3303280	16.84	-32.60	49.44	16.72	0.10	0.02	Average
8	@0.3303280	24.62	-34.82	59.44	24.50	0.10	0.02	QP
9	@0.4711010	23.96	-32.53	56.49	23.84	0.10	0.02	QP
10	@0.4711010	16.68	-29.81	46.49	16.56	0.10	0.02	Average
11	@ 1.550	3.37	-42.63	46.00	3.24	0.10	0.03	Average
12	@ 1.550	8.06	-47.94	56.00	7.93	0.10	0.03	QP

Neutral to Ground

	Freq	Level	Over Limit	Limit Line	Read Level	LISN Factor	Cable Loss	Remark
	MHz	dBuV	dB	dBuV	dBuV	dB	dB	
1	@0.1573260	24.19	-41.41	65.60	24.08	0.10	0.01	QP
2	@0.1573260	11.20	-44.40	55.60	11.09	0.10	0.01	Average
3	@0.1777150	8.17	-46.42	54.59	8.06	0.10	0.01	Average
4	@0.1777150	23.25	-41.34	64.59	23.14	0.10	0.01	QP
5	@0.2061360	21.74	-41.62	63.36	21.63	0.10	0.01	QP
6	@0.2061360	7.76	-45.60	53.36	7.65	0.10	0.01	Average
7	@0.2893470	9.92	-40.62	50.54	9.80	0.10	0.02	Average
8	@0.2893470	20.08	-40.46	60.54	19.96	0.10	0.02	QP
9	@0.6075240	14.10	-41.90	56.00	13.97	0.10	0.03	QP
10	@0.6075240	3.44	-42.56	46.00	3.31	0.10	0.03	Average
11	@ 1.750	3.32	-42.68	46.00	3.20	0.10	0.02	Average
12	@ 1.750	8.35	-47.65	56.00	8.23	0.10	0.02	QP

Test Engineer : 
 Brian Lin

5.7.4. Photographs of Conducted Emission Test Configuration

- The photographs show the configuration that generates the maximum emission.

FRONT VIEW

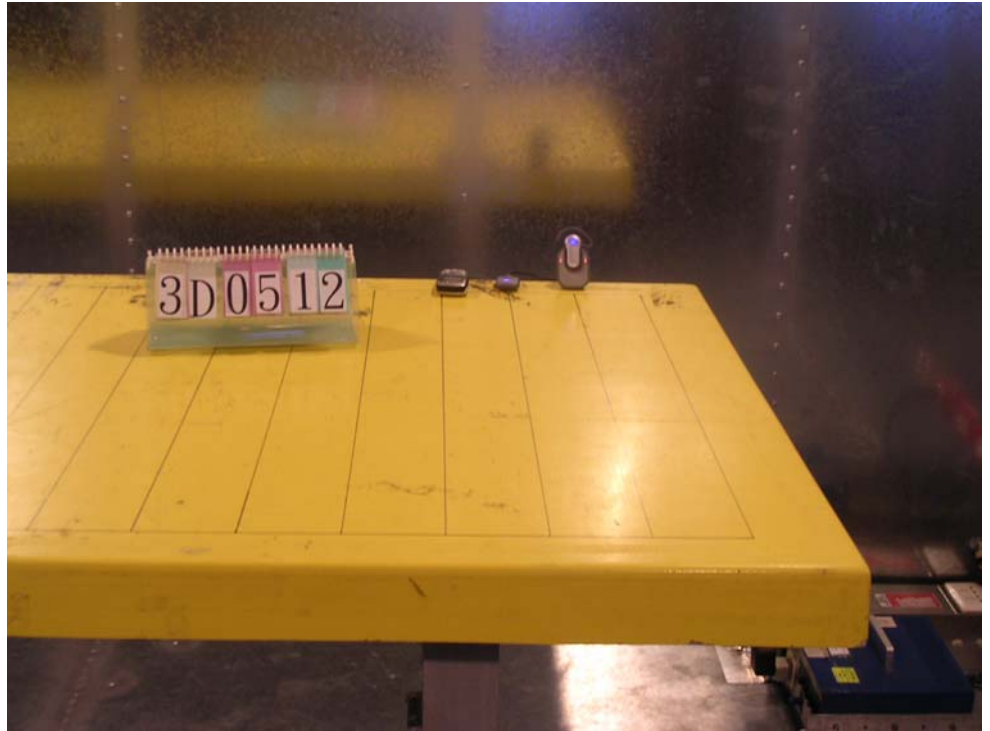

REAR VIEW





5.8. Test of Spurious Radiated Emission

5.8.1. Measuring Instruments

Please reference item 8~19 in chapter 6 for the instruments used for testing.

5.8.2. Test Procedures

1. Configure the EUT according to ANSI C63.4.
2. The EUT was placed on the top of the turn table 0.8 meter above ground.
3. The phase center of the receiving antenna mounted on the top of a height-variable antenna tower was placed 3 meters far away from the turn table.
4. Power on the EUT and all the supporting units.
5. The turn table was rotated by 360 degrees to determine the position of the highest radiation.
6. The height of the broadband receiving antenna was varied between one meter and four meters above ground to find the maximum emission field strength of both horizontal and vertical polarization.
7. For each suspected emission, the antenna tower was scan (from 1 M to 4 M) and then the turn table was rotated (from 0 degree to 360 degrees) to find the maximum reading.
8. Set the test-receiver system to Peak or CISPR quasi-peak Detect Function with specified bandwidth under Maximum Hold Mode.
9. For emission above 1GHz, use 1MHz VBW & RBW for peak reading and 1MHz RBW & 300Hz VBW for average reading in spectrum analyzer.
10. If the emission level of the EUT in peak mode was 3 dB lower than the limit specified, then testing will be stopped and peak values of EUT will be reported, otherwise, the emissions which do not have 3 dB margin will be repeated one by one using the quasi-peak method and reported.
11. For testing above 1GHz, the emission level of the EUT in peak mode was 20dB higher than average limit (that means the emission level in peak mode also complies with the limit in average mode), then testing will be stopped and peak values of EUT will be reported, otherwise, the emissions will be measured in average mode again and reported. (For peak measurement, RB=VB=1MHz, for average measurement, RB=1MHz, VB=10Hz)

5.8.3. Test Setup Layout

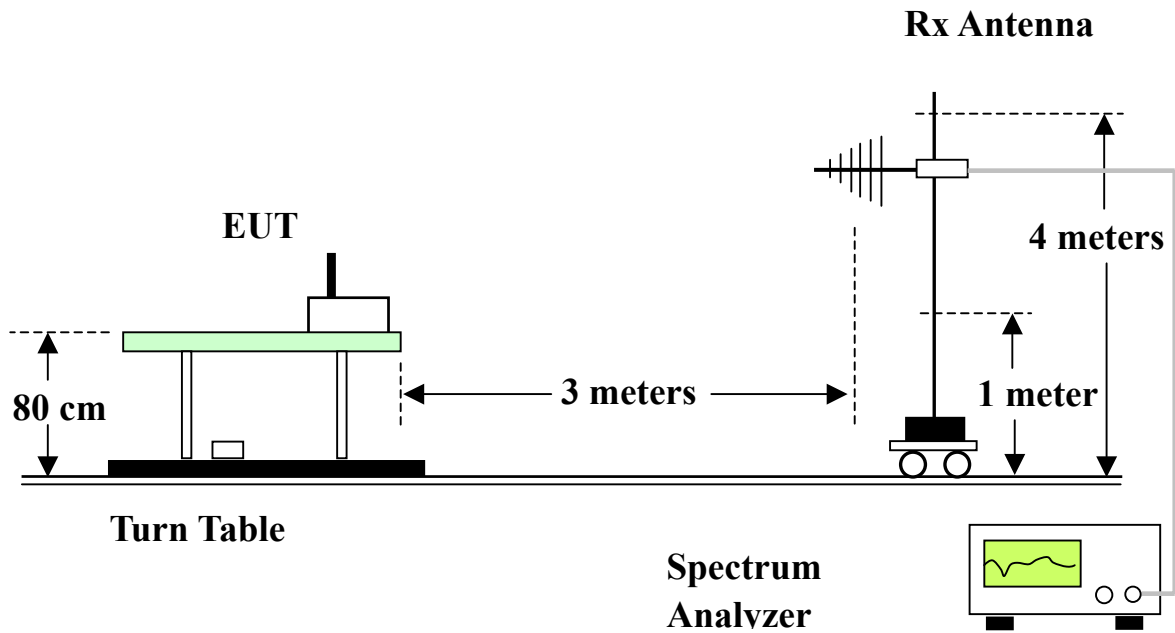



5.8.4. Test Results and Limit

Note:

Emission level (dBuV/m) = 20 log Emission level (uV/m)

Corrected Reading: Probe Factor + Cable Loss + Read Level - Preamp Factor = Level

Test Mode	RF LINK	Temperature	26 deg. C	Tested By	Steve Chen
Freq. Range	30MHz~1GHz	Humidity	62%		

(A) Polarization: Horizontal

	Freq	Level	Over Limit	Limit Line	Read Level	Probe Factor	Cable Loss	Preamp Factor	Remark	Ant Pos	Table Pos
	MHz	dBuV/m	dB	dBuV/m	dBuV	dB	dB	dB		cm	deg
1	118.740	30.01	-13.49	43.50	45.36	10.56	1.95	27.86	QP	---	---
2	161.070	29.93	-13.57	43.50	42.65	12.75	2.31	27.78	QP	---	---
3	195.070	30.14	-13.36	43.50	40.65	14.69	2.51	27.71	QP	---	---
1	218.400	28.97	-17.03	46.00	39.76	14.19	2.65	27.63	QP	---	---
2	228.000	28.92	-17.08	46.00	40.19	13.60	2.72	27.59	QP	---	---
3	601.600	29.43	-16.57	46.00	34.85	18.99	4.39	28.80	QP	---	---

(B) Polarization: Vertical

	Freq	Level	Over Limit	Limit Line	Read Level	Probe Factor	Cable Loss	Preamp Factor	Remark	Ant Pos	Table Pos
	MHz	dBuV/m	dB	dBuV/m	dBuV	dB	dB	dB		cm	deg
1	30.000	30.15	-9.85	40.00	42.79	14.47	0.94	28.05	QP	100	125
2	51.420	28.30	-11.70	40.00	44.97	10.13	1.20	28.00	QP	---	---
3	133.190	25.64	-17.86	43.50	39.95	11.49	2.03	27.83	QP	---	---
1	601.600	28.24	-17.76	46.00	33.66	18.99	4.39	28.80	QP	---	---
2	816.000	27.28	-18.72	46.00	30.35	20.53	5.12	28.72	QP	---	---
3	848.800	28.35	-17.65	46.00	30.79	20.85	5.26	28.55	QP	---	---



Test Mode	CHARGER	Temperature	26 deg. C	Tested By	Steve Chen
Freq. Range	30MHz~1GHz	Humidity	62%		

(A) Polarization: Horizontal

	Freq	Level	Over Limit	Limit Line	Read Level	Probe Factor	Cable Loss	Preamp Factor	Remark	Ant Pos	Table Pos
	MHz	dBuV/m	dB	dBuV/m	dBuV	dB	dB	dB		cm	deg
1	141.860	20.03	-23.47	43.50	33.91	11.86	2.08	27.82	QP	---	---
2	145.940	20.73	-22.77	43.50	34.25	12.12	2.17	27.81	QP	100	131
3	167.190	21.13	-22.37	43.50	33.45	13.10	2.34	27.76	QP	---	---

(B) Polarization: Vertical

	Freq	Level	Over Limit	Limit Line	Read Level	Probe Factor	Cable Loss	Preamp Factor	Remark	Ant Pos	Table Pos
	MHz	dBuV/m	dB	dBuV/m	dBuV	dB	dB	dB		cm	deg
1	61.110	14.84	-25.16	40.00	31.54	9.97	1.31	27.98	QP	---	---
2	67.230	15.41	-24.59	40.00	32.95	9.04	1.38	27.96	QP	---	---
3	71.310	15.17	-24.83	40.00	32.75	8.96	1.42	27.96	QP	---	---



Test Mode	Mode 1 (2402MHz)	Temperature	26 deg. C	Tested By	Steve Chen
Freq. Range	1GHz~25GHz	Humidity	62%		

Horizontal

	Freq	Level	Over Limit	Limit Line	Read Level	Probe Factor	Cable Loss	Preamp Factor	Remark	Ant Pos	Table Pos
	MHz	dBuV/m	dB	dBuV/m	dBuV	dB	dB	dB		cm	deg
1	1470.000	40.70	-13.30	54.00	54.66	25.16	1.46	40.58	Average	---	---
2	1806.000	40.99	-13.01	54.00	53.79	26.40	1.59	40.79	Average	---	---
3	2372.000	41.36	-12.64	54.00	52.70	28.09	1.70	41.13	Average	---	---
4 X	2404.000	67.85			79.09	28.18	1.73	41.15	Average	---	---
5 X	2404.000	88.53			99.77	28.18	1.73	41.15	Peak	---	---
6	2436.000	39.72	-14.28	54.00	50.87	28.26	1.76	41.17	Average	---	---
1	4804.000	46.89	-7.11	54.00	53.64	33.19	2.40	42.34	Average	---	---

Vertical

	Freq	Level	Over Limit	Limit Line	Read Level	Probe Factor	Cable Loss	Preamp Factor	Remark	Ant Pos	Table Pos
	MHz	dBuV/m	dB	dBuV/m	dBuV	dB	dB	dB		cm	deg
1	1798.000	37.70	-16.30	54.00	50.55	26.36	1.58	40.79	Average	---	---
2	2372.000	40.58	-13.42	54.00	51.92	28.09	1.70	41.13	Average	---	---
3 X	2404.000	89.15			100.39	28.18	1.73	41.15	Peak	---	---
4 X	2404.000	67.12			78.36	28.18	1.73	41.15	Average	---	---
5	2436.000	39.00	-15.00	54.00	50.15	28.26	1.76	41.17	Average	---	---
1	4804.000	49.02	-4.98	54.00	55.77	33.19	2.40	42.34	Average	100	126



Test Mode	Mode 2 (2441MHz)	Temperature	26 deg. C	Tested By	Steve Chen
Freq. Range	1GHz~25GHz	Humidity	62%		

(A) Polarization: Horizontal

	Freq	Level	Over Limit	Limit Line	Read Level	Probe Factor	Cable Loss	Preamp Factor	Remark	Ant Pos	Table Pos
	MHz	dBuV/m	dB	dBuV/m	dBuV	dB	dB	dB		cm	deg
1	1806.000	44.31	-9.69	54.00	57.11	26.40	1.59	40.79	Average	---	---
2	2012.000	37.17	-16.83	54.00	49.37	27.14	1.57	40.91	Average	---	---
3	2412.000	42.23	-11.77	54.00	53.44	28.20	1.74	41.15	Average	---	---
4 X	2444.000	88.65			99.77	28.28	1.77	41.17	Peak	---	---
5 X	2444.000	68.54			79.66	28.28	1.77	41.17	Average	---	---
6	2476.000	37.54	-16.46	54.00	48.55	28.37	1.81	41.19	Average	---	---
1	4884.000	50.23	-3.77	54.00	56.80	33.37	2.51	42.45	Average	---	---

(B) Polarization: Vertical

	Freq	Level	Over Limit	Limit Line	Read Level	Probe Factor	Cable Loss	Preamp Factor	Remark	Ant Pos	Table Pos
	MHz	dBuV/m	dB	dBuV/m	dBuV	dB	dB	dB		cm	deg
1	1134.000	38.83	-15.17	54.00	53.65	24.20	1.23	40.25	Average	---	---
2	1804.000	38.55	-15.45	54.00	51.36	26.39	1.59	40.79	Average	---	---
3	2412.000	43.31	-10.69	54.00	54.52	28.20	1.74	41.15	Average	---	---
4 X	2438.000	88.64			99.78	28.27	1.76	41.17	Peak	---	---
5 X	2438.000	68.32			79.46	28.27	1.76	41.17	Average	---	---
6	2476.000	40.22	-13.78	54.00	51.23	28.37	1.81	41.19	Average	---	---
1	4884.000	50.49	-3.51	54.00	57.06	33.37	2.51	42.45	Average	100	127



Test Mode	Mode 3 (2480MHz)	Temperature	26 deg. C	Tested By	Steve Chen
Freq. Range	1GHz~25GHz	Humidity	62%		

Horizontal

	Freq	Level	Over Limit	Limit Line	Read Level	Probe Factor	Cable Loss	Preamp Factor	Remark	Ant Pos	Table Pos
	MHz	dBuV/m	dB	dBuV/m	dBuV	dB	dB	dB		cm	deg
1	1196.000	34.86	-19.14	54.00	49.57	24.38	1.22	40.31	Average	---	---
2	1238.000	35.62	-18.38	54.00	50.16	24.50	1.31	40.35	Average	---	---
3	1806.000	44.78	-9.22	54.00	57.58	26.40	1.59	40.79	Average	---	---
4	2446.000	40.96	-13.04	54.00	52.07	28.29	1.77	41.17	Average	---	---
5 X	2478.000	84.95			95.96	28.37	1.81	41.19	Peak	---	---
6 X	2478.000	64.48			75.49	28.37	1.81	41.19	Average	---	---
1	4958.000	51.25	-22.75	74.00	57.84	33.53	2.44	42.56	Peak	---	---
2	4958.000	39.73	-14.27	54.00	46.32	33.53	2.44	42.56	Average	---	---

Vertical

	Freq	Level	Over Limit	Limit Line	Read Level	Probe Factor	Cable Loss	Preamp Factor	Remark	Ant Pos	Table Pos
	MHz	dBuV/m	dB	dBuV/m	dBuV	dB	dB	dB		cm	deg
1	1198.000	34.27	-19.73	54.00	48.98	24.38	1.22	40.31	Average	---	---
2	1238.000	36.09	-17.91	54.00	50.63	24.50	1.31	40.35	Average	---	---
3	1806.000	36.50	-17.50	54.00	49.30	26.40	1.59	40.79	Average	---	---
4	2446.000	41.57	-12.43	54.00	52.68	28.29	1.77	41.17	Average	---	---
5 X	2478.000	87.89			98.90	28.37	1.81	41.19	Peak	---	---
6 X	2478.000	67.57			78.58	28.37	1.81	41.19	Average	---	---
7	2510.000	38.20	-15.80	54.00	49.07	28.47	1.86	41.20	Average	---	---
1	4958.000	49.68	-4.32	54.00	56.27	33.53	2.44	42.56	Average	100	125

- For 5GHz ~ 25GHz
 Remark: Frequency from 1000MHz to 12500MHz, the emission emitted by the EUT is too low to be measured.

5.8.5. Photographs of Radiated Emission Test Configuration

- The photographs show the configuration that generates the maximum emission.

FRONT VIEW



REAR VIEW

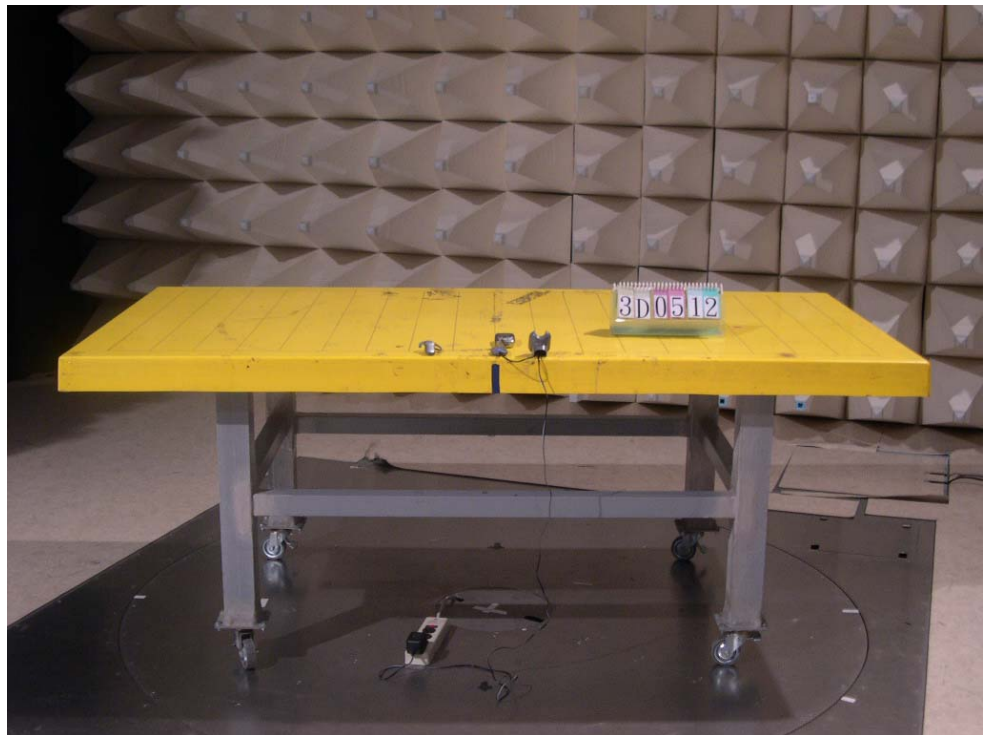



5.9. Antenna Requirements

5.9.1. Standard Applicable

47 CFR Part15 Section 15.203:

An intentional radiator shall be designed to ensure that no antenna other than that furnished by the responsible party shall be used with the device.

47 CFR Part15 Section 15.247 (b):

If transmitting antennas of directional gain greater than 6 dBi are used, the peak output power from the intentional radiator shall be reduced by the amount in dB that the directional gain of the antenna exceeds 6 dBi.

If the intentional radiator is used exclusively for fixed, point-to-point operations may employ transmitting antennas with directional gain greater than 6 dBi provided the maximum peak output power of the intentional radiator is reduced by 1 dB for every 3 dB that the directional gain of the antenna exceeds 6 dBi.

5.9.2. Antenna Connector Used in this Product

The maximum Gain antenna used in this product is an internal ceramic antenna without connector.



5.10. RF Exposure

5.10.1. Limit For Maximum Permissible Exposure (MPE)

This product can be classified as mobile device, so the 20cm separation distance warning is required.

In this section, the power density at 20cm location is calculated to examine if it is lower than the limit.

(A) Limits for Occupational / Controlled Exposure

Frequency Range (MHz)	Electric Field Strength (E) (V/m)	Magnetic Field Strength (H) (A/m)	Power Density (S) (mW/ cm ²)	Averaging Time E ² , H ² or S (minutes)
0.3-3.0	614	1.63	(100)*	6
3.0-30	1842 / f	4.89 / f	(900 / f)*	6
30-300	61.4	0.163	1.0	6
300-1500			F/300	6
1500-100,000			5	6

(B) Limits for General Population / Uncontrolled Exposure

Frequency Range (MHz)	Electric Field Strength (E) (V/m)	Magnetic Field Strength (H) (A/m)	Power Density (S) (mW/cm ²)	Averaging Time E ² , H ² or S (minutes)
0.3-1.34	614	1.63	(100)*	30
1.34-30	824/f	2.19/f	(180/f)*	30
30-300	27.5	0.073	0.2	30
300-1500			F/1500	30
1500-100,000			1.0	30

F = frequency in MHz

*Plane-wave equivalent power density



5.10.2. MPE Calculation Method

$$E \text{ (V/m)} = \frac{\sqrt{30 \times P \times G}}{d}$$

$$\text{Power Density: } Pd \text{ (mW/cm}^2\text{)} = \frac{E^2}{377}$$

- E** = Electric field (V/m)
- P** = Peak RF output power (mW)
- G** = EUT Antenna numeric gain (numeric)
- d** = Separation distance between radiator and human body (m)

The formula can be changed to

$$Pd = \frac{30 \times P \times G}{377 \times d^2}$$

From the peak EUT RF output power, the minimum mobile separation distance, d=20cm, as well as the gain of the used antenna, the RF power density can be obtained.

5.10.3. Calculated Result and Limit

Channel No.	Antenna Gain (dBi)	Antenna Gain (numeric)	Peak Output Power (dBm)	Peak Output Power (mW)	Power Density (S) (mW/cm ²)	Limit of Power Density (S) (mW/cm ²)
Channel 00	-0.1	0.98	2.4600	1.7620	0.0003	1
Channel 39	-0.1	0.98	2.0300	1.5959	0.0003	1
Channel 78	-0.1	0.98	2.2000	1.6596	0.0003	1



6. List of Measuring Equipments Used

Items	Instrument	Manufacturer	Model No.	Serial No.	Characteristics	Calibration Date	Remark
1	EMC Receiver	R&S	ESCS 30	100132	9 KHz – 2.75 GHz	Jun. 12, 2003	Conduction (CO01-HY)
2	LISN	MessTec	NNB-2/16Z	2001/004	9 KHz – 30 MHz	Jun. 02, 2004	Conduction (CO01-HY)
3	LISN (Support Unit)	MessTec	NNB-2/16Z	99041	9 KHz – 30 MHz	Apr. 03, 2004	Conduction (CO01-HY)
4	EMI Filter	LINDGREN	LRE-2060	1004	< 450 Hz	N/A	Conduction (CO01-HY)
5	EMI Filter	LINDGREN	N6006	201052	0 ~ 60 Hz	N/A	Conduction (CO01-HY)
6	RF Cable-CON	Suhner Switzerland	RG223/U	CB029	9KHz~30MHz	Dec. 24, 2003	Conduction (CO01-HY)
7	50 ohm BNC type Terminal	NOBLE	50ohm	TM004	50 ohm	Apr. 07, 2004	Conduction (CO01-HY)
8	3m Semi Anechoic Chamber	SIDT FRANKONIA	SAC-3M	03CH03-HY	30MHz~1GHz 3m	Jun. 21, 2003	Radiation (03CH03-HY)
9	Spectrum analyzer	R&S	FSP40	100004	9KHZ~40GHZ	Aug. 23, 2003	Radiation (03CH03-HY)
10	Amplifier	HP	8447D	2944A09072	100KHz – 1.3GHz	Nov. 05, 2003	Radiation (03CH03-HY)
11	Biconical Antenna	SCHWARZBECK	VHBB 9124	301	30MHz –200MHz	Jul. 24, 2003	Radiation (03CH03-HY)
12	Log Antenna	SCHWARZBECK	VUSLP 9111	221	200MHz -1GHz	Jul. 24, 2003	Radiation (03CH03-HY)
13	RF Cable-R03m	Jye Bao	RG142	CB021	30MHz~1GHz	Dec. 03, 2003	Radiation (03CH03-HY)
14	Amplifier	MITEQ	AFS44	879981	100MHz~26.5GHz	Jul. 23, 2003	Radiation (03CH03-HY)
15	Horn Antenna	COM-POWER	3115	6821	1GHz – 18GHz	Sep. 12, 2003	Radiation (03CH03-HY)
16	Turn Table	HD	DS 420	420/650/00	0 ~ 360 degree	N/A	Radiation (03CH03-HY)
17	Antenna Mast	HD	MA 240	240/560/00	1 m - 4 m	N/A	Radiation (03CH03-HY)
18	Horn Antenna	Schwarzbeck	BBHA9170	154	15GHz~40GHz	Jun. 02, 2003	Radiation (03CH03-HY)
19	RF Cable-HIGH	Jye Bao	RG142	CB030-HIGH	1GHz~29.5GHz	Dec. 05, 2003	Radiation (03CH03-HY)

※ Calibration Interval of instruments listed above is one year.



Items	Instrument	Manufacturer	Model No.	Serial No.	Characteristics	Calibration Date	Remark
19	Spectrum analyzer	R&S	FSP7	838858/014	9KHZ~7GHZ	Sep. 03, 2003	Conducted
20	Power meter	R&S	NRVS	100444	DC~40GHz	May 28, 2003	Conducted
21	Power sensor	R&S	NRV-Z55	100049	DC~40GHz	May 28, 2003	Conducted
22	Power Sensor	R&S	NRV-Z32	100057	30MHz-6GHz	May 28, 2003	Conducted
23	AC power source	HPC	HPA-500W	HPA-9100024	AC 0~300V	May 27, 2003	Conducted
24	AC power source	G.W.	GPC-6030D	C671845	DC 1V~60V	Nov. 06, 2003	Conducted
25	Temp. and Humidity Chamber	KSON	THS-C3L	612	N/A	Oct. 01, 2003	Conducted
26	RF CABLE-1m	Jye Bao	RG142	CB034-1m	20MHz~7GHz	Jan. 01, 2004	Conducted
27	RF CABLE-2m	Jye Bao	RG142	CB035-2m	20MHz~1GHz	Jan. 01, 2004	Conducted

※ Calibration Interval of instruments listed above is one year.