

BELKIN®

LineCast Auto FM

User Manual

8820tt00824 Rev. A00 F8M120/F8M120tt

TABLE OF CONTENTS

Table of Contents	SECTIONS	1	2	3	4	5	6
1 Introduction		1					
2 Initial Setup		3					
Place the Mounting Disc		5					
Attach the LineCast Auto FM		5					
3 Daily Use		5					
Connecting		5					
Phone and Music Controls		5					
LineCast Auto FM – Button Functions		6					
Online Audio Services		7					
Transferring Audio Back to Your Phone		7					
Turning the Product Off		7					
4 Troubleshooting					8		
5 Safety Warnings						9	
6 Information							10

INTRODUCTION

Table of Contents

SECTIONS

1

2

3

4

5

6

Features

- Talk hands-free on your mobile phone.
- Listen to iTunes music or other audio files, including Internet radio, from your phone through your car stereo.

INTRODUCTION

Table of Contents	SECTIONS	1	2	3	4	5	6
-------------------	----------	---	---	---	---	---	---

What's in the Box

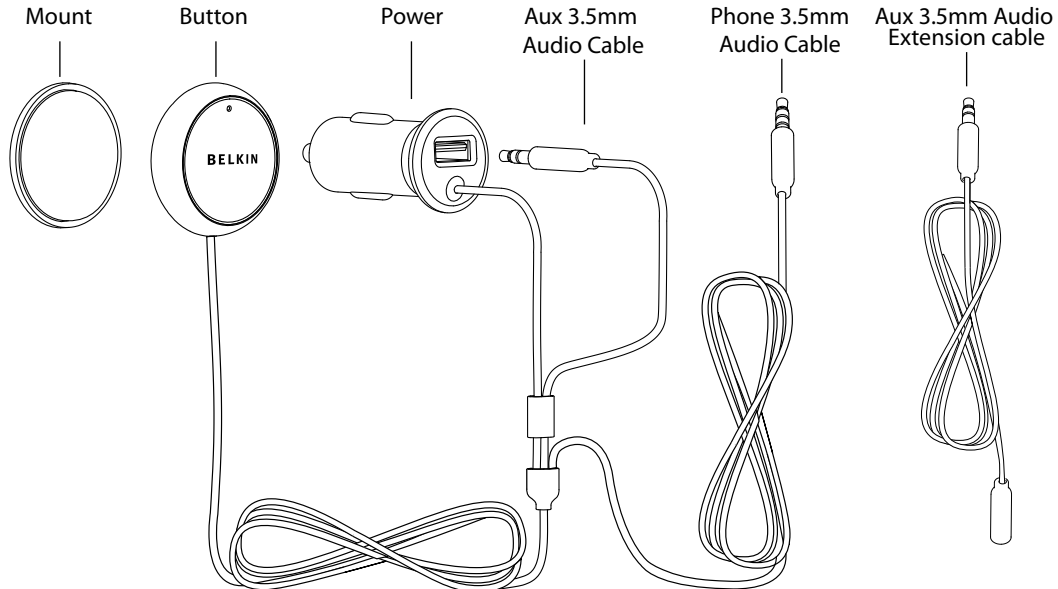

INITIAL SETUP

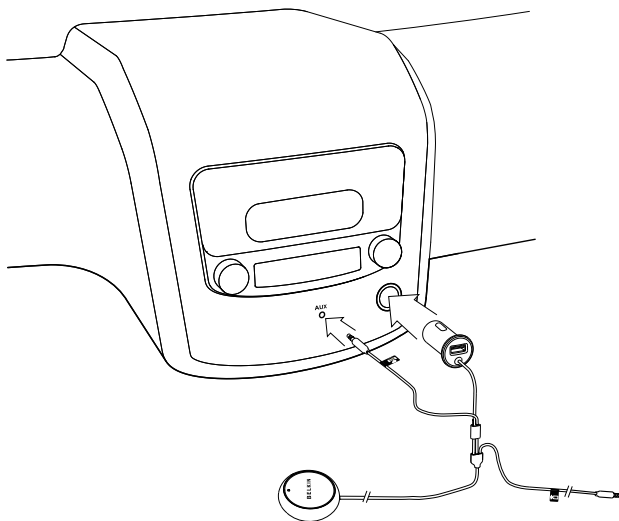

1. Insert the power plug into your car's 12V power outlet (also known as the cigarette lighter). The light ring around the multi-function button will turn on in orange.
2. Press the ClearScan button on top of the product to find an FM frequency that's clear.*
3. Store that frequency in memory by pressing and holding one of the two MEM buttons. When the frequency is stored successfully, the product will beep and MEMORY 1 or MEMORY 2 will show on the display.
4. Turn on your car stereo and set the input source to FM.
5. Tune your car stereo so that its FM frequency matches the LineCast Auto FM.
6. If possible, store the frequency in one of your car stereo's preset buttons. Typically this is done by pressing and holding the chosen preset button until the stereo beeps or gives some indication that the frequency has been stored.
7. Insert the product's audio cable into the headphone jack of your phone.

***If you hear static as you travel from one part of town to another, press the ClearScan button again to find a better frequency.**

INITIAL SETUP

Table of Contents

SECTIONS

1

2

3

4

5

6

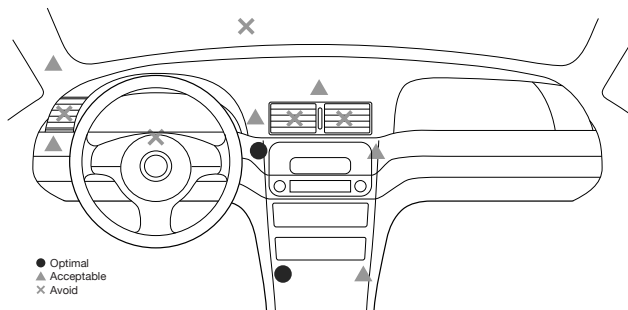

Place the Mounting Disc

1. Find a smooth and flat surface on the dashboard in front of you that is within easy reach but will not interfere with driving. The LineCast Auto FM has a built-in microphone and should be as directly in front of you as possible. See image for some recommended areas:
2. Clean the surface with an alcohol swab if possible, or with a cleaner that can remove any residue from polish/shine products that have been sprayed on the dash in the past. Please make sure to read all instructions on the cleaner to make sure it is safe to use on dashboards.
3. Peel away the back of the mounting disc to expose the adhesive and stick it to the dashboard.

Attach the LineCast Auto FM

The product will magnetically attach to the mounting disc. The product can be easily removed and stored when not in use.

DAILY USE

Connecting

To connect to the LineCast Auto FM:

1. Connect the product's audio cable to the headphone jack on your phone.
2. Make sure there's power to the LineCast Auto FM—the light ring will be orange.
3. Turn on your car stereo, set the source to FM, and match the frequency shown on the LineCast Auto FM.
4. If you're already on a call or listening to music, the audio will transfer to your car speakers.

Note: After 10 minutes of inactivity, the LineCast Auto FM will go into sleep mode and the light ring will turn off. When that happens, tap the button to wake it.

DAILY USE

Table of Contents	SECTIONS	1	2	3	4	5	6
-------------------	----------	---	---	---	---	---	---

Phone and Music Controls

LineCast Auto FM can control some of the main phone functions that you'd use while driving. It does this via the headphone cable. Mobile phones vary tremendously in terms of what commands work with them, depending on wireless carrier, manufacturer, and model. Shown below is the common set of functions with a common set of phones. Your phone may match the button functions shown, or it may vary. When your car is parked, experiment with which functions work with your phone, and write them down here.

LineCast Auto FM - Button Functions

Legend:	compatible	partially compatible
---------	------------	----------------------

Phone Brand	Phone Model	Answer call	End call	Pause/Play Music	Skips songs forward	Skip songs back	Voice-dialing	Comments
Apple	iPhone 4	Tap	Tap	Tap	Double-tap	Triple-tap	Press/hold more than 1 sec	
Apple	iPhone 3GS	Tap	Tap	Tap	Double-tap	Triple-tap	Press/hold more than 1 sec	
Blackberry	Bold	Tap	Press & Hold	Tap	Not available	Not available	press and hold for 5 seconds	
Blackberry	Curve (T-Mobile)	Tap	Press & Hold	Tap	Not available	Not available	FPO	-When on a call, tapping the button will cause the phone to mute. -If you try to pause/un-pause music and voice-dialing starts instead, use your phone's controls for music instead.
HTC	Nexus One	Tap	Press & Hold	Tap	Double-tap	Not available	Not available	
HTC	Droid (Hero)	Tap	Press & Hold	Tap	Not available	Not available	Press/hold more than 1 sec	If you try to pause/un-pause music and voice-dialing starts instead, use your phone's controls for music instead.
HTC	EVO	Tap	Press & Hold	Not available	Not available	Not available	Not available	
Samsung	Galaxy S	Tap	Tap	Tap	Not available	Not available	Not available	Some phone models do not support the pause/un-pause music function.

My phone	Answer call:	End call:	Pause/play music:	Skip songs forward:	Skip songs back:	Voice-dialing:	Notes:
----------	--------------	-----------	-------------------	---------------------	------------------	----------------	--------

Online Audio Services

If you use audio-streaming services Pandora® or iheartradio®, you might be able to use LineCast Auto FM to listen to the streaming audio through your car stereo. However, not all phones or audio-streaming services support this feature. Experiment with your particular app while parked: when it's playing, see if the sound comes out of your car speakers. See what happens when you tap the LineCast Auto FM button. Tap it once, and then tap it again. Tap it twice slowly, and then more quickly. Your app might play, pause, and skip forward.

app:	single tap	single tap	double tap - slow	double tap - fast
app:	single tap	single tap (again)	double tap - slow	double tap - fast

Transferring Audio Back to Your Phone

Simply remove the cable from the phone.

Turning the Product Off

It is normally not necessary to turn the product off, since turning the car off will usually cut power to the car's power plug (also known as a cigarette lighter adapter).

However, some cars have a power plug that stays on even when the car is off. If you have a car like that, LineCast Auto FM will automatically go into a very low-power sleep mode after 10 minutes of inactivity and the light ring will turn off. If you want to put the product into sleep mode immediately, press and hold the button until the light ring turns off.

TROUBLESHOOTING

You can quickly solve most problems with your LineCast Auto FM by following the advice in this section.

The audio is not coming out of the stereo speakers.

- Make sure both the car stereo and the LineCast Auto FM are powered on.
- Make sure the car stereo is set to FM, and the frequency matches that shown on the LineCast Auto FM.
- Make sure the stereo volume is set to a comfortable listening level.
- Make sure the phone's volume is set to a comfortable level, and is not muted.
- Make sure that your phone or device is connected to the LineCast Auto FM via the product's audio cable.

I can't control music playback using the button.

- Refer to the chart provided in the "Phone and Music Controls" section of this manual.
- Unfortunately not all phones will support this feature. This is a result of how various phone manufacturers design their audio jacks, and how various carriers implement their features.

SAFETY WARNINGS

Your LineCast Auto FM requires full concentration and both hands to install. **Do not attempt to connect your LineCast Auto FM while driving. Do not attempt to adjust or retrieve an unsecured LineCast Auto FM while driving.** Adjust the position of your LineCast Auto FM so that it does not interfere with any of the operating controls of the vehicle or your view of the road.

Do not use this apparatus near water (for example, a bath tub, wash bowl, kitchen sink, laundry tub, wet basement, swimming pool, or other areas located near water).

Unplug this product from the cigarette lighter or power outlet before cleaning. Clean only with a dry cloth.

Unplug this apparatus when unused for long periods of time.

Only use attachments/accessories specified by the manufacturer.

Belkin does not assume any responsibility for personal injury or property damage incurred due to hazardous driving as a result of interaction with the LineCast Auto FM, iPhone, iPod, or other device.

INFORMATION

Table of Contents	SECTIONS	1	2	3	4	5	6
-------------------	----------	---	---	---	---	---	---

FCC Statement

This device complies with part 15 of the FCC Rules. Operation is subject to the following two conditions:

- (1) this device may not cause harmful interference, and
- (2) this device must accept any interference received, including interference that may cause undesired operation.

This equipment has been tested and found to comply with the limits for a Class B digital device, pursuant to part 15 of the FCC Rules. These limits are designed to provide reasonable protection against harmful interference in a residential installation. This equipment generates, uses, and can radiate radio frequency energy and, if not installed and used in accordance with the instructions, may cause harmful interference to radio communications. However, there is no guarantee that interference will not occur in a particular installation. If this equipment does cause harmful interference to radio or television reception, which can be determined by turning the equipment off and on, the user is encouraged to try to correct the interference by one of the following measures:

- Reorient or relocate the receiving antenna.
- Increase the separation between the equipment and receiver.
- Connect the equipment into an outlet on a circuit different from that which the receiver is connected.
- Consult the dealer or an experienced radio/TV technician for help.

Belkin International, Inc., is not responsible for any interference caused by unauthorized modifications to this equipment. Such modifications could void the user's authority to operate this equipment.

FCC Caution: Any changes or modifications not expressly approved by the party responsible for compliance could void the user's authority to operate this equipment.

ICES

This Class B digital apparatus complies with Canadian ICES-003.

IC

This Class B digital apparatus complies with Canada RSS-210.

Europe – EU Declaration of Conformity

This device complies with the essential requirements of the R&TTE Directive 1999/5/EC, the EMC Directive 2004/108/EC, and the low-voltage Directive 2006/95/EC. A copy of the European Union CE marking "Declaration of Conformity" may be obtained at the website: www.belkin.com/doc



INFORMATION

Belkin International, Inc., Limited 1-Year Product Warranty

What this warranty covers.

Belkin International, Inc. (“Belkin”) warrants to the original purchaser of this Belkin product that the product shall be free of defects in design, assembly, material, or workmanship.

What the period of coverage is.

Belkin warrants the Belkin product for one year.

What will we do to correct problems?

Product Warranty.

Belkin will repair or replace, at its option, any defective product free of charge (except for shipping charges for the product). Belkin reserves the right to discontinue any of its products without notice, and disclaims any limited warranty to repair or replace any such discontinued products. In the event that Belkin is unable to repair or replace the product (for example, because it has been discontinued), Belkin will offer either a refund or a credit toward the purchase of another product from Belkin.com in an amount equal to the purchase price of the product as evidenced on the original purchase receipt as discounted by its natural use.

What is not covered by this warranty?

All above warranties are null and void if the Belkin product is not provided to Belkin for inspection upon Belkin’s request at the sole expense of the purchaser, or if Belkin determines that the Belkin product has been improperly installed, altered in any way, or tampered with. The Belkin Product Warranty does not protect against acts of God such as flood, lightning, earthquake, war, vandalism, theft, normal-use wear and tear, erosion, depletion, obsolescence, abuse, damage due to low voltage disturbances (i.e. brownouts or sags), non-authorized program, or system equipment modification or alteration.

How to get service.

To get service for your Belkin product you must take the following steps:

1. Contact Belkin International, Inc., at 12045 E. Waterfront Drive, Playa Vista, CA 90094, Attn: Customer Service, or call (800)-223-5546, within 15 days of the Occurrence. Be prepared to provide the following information:
 - a. The part number of the Belkin product.
 - b. Where you purchased the product.
 - c. When you purchased the product.
 - d. Copy of original receipt.
2. Your Belkin Customer Service Representative will then instruct you on how to forward your receipt and Belkin product and how to proceed with your claim.

INFORMATION

Table of Contents

SECTIONS

1

2

3

4

5

6

Belkin reserves the right to review the damaged Belkin product. All costs of shipping the Belkin product to Belkin for inspection shall be borne solely by the purchaser. If Belkin determines, in its sole discretion, that it is impractical to ship the damaged equipment to Belkin, Belkin may designate, in its sole discretion, an equipment repair facility to inspect and estimate the cost to repair such equipment. The cost, if any, of shipping the equipment to and from such repair facility and of such estimate shall be borne solely by the purchaser. Damaged equipment must remain available for inspection until the claim is finalized. Whenever claims are settled, Belkin reserves the right to be subrogated under any existing insurance policies the purchaser may have.

How state law relates to the warranty.

THIS WARRANTY CONTAINS THE SOLE WARRANTY OF BELKIN. THERE ARE NO OTHER WARRANTIES, EXPRESSED OR, EXCEPT AS REQUIRED BY LAW, IMPLIED, INCLUDING THE IMPLIED WARRANTY OR CONDITION OF QUALITY, MERCHANTABILITY OR FITNESS FOR A PARTICULAR PURPOSE, AND SUCH IMPLIED WARRANTIES, IF ANY, ARE LIMITED IN DURATION TO THE TERM OF THIS WARRANTY.

Some states do not allow limitations on how long an implied warranty lasts, so the above limitations may not apply to you.

IN NO EVENT SHALL BELKIN BE LIABLE FOR INCIDENTAL, SPECIAL, DIRECT, INDIRECT, CONSEQUENTIAL OR MULTIPLE DAMAGES SUCH AS, BUT NOT LIMITED TO, LOST BUSINESS OR PROFITS ARISING OUT OF THE SALE OR USE OF ANY BELKIN PRODUCT, EVEN IF ADVISED OF THE POSSIBILITY OF SUCH DAMAGES.

This warranty gives you specific legal rights, and you may also have other rights, which may vary from state to state. Some states do not allow the exclusion or limitation of incidental, consequential, or other damages, so the above limitations may not apply to you.

BELKIN®

www.belkin.com

Belkin Tech Support

US

<http://www.belkin.com/support>

UK

<http://www.belkin.com/uk/support>

Australia

<http://www.belkin.com/au/support>

New Zealand

<http://www.belkin.com/au/support>

Singapore

1800 622 1130

Europe

<http://www.belkin.com/uk/support>

© 2011 Belkin International, Inc. All rights reserved. All trade names are registered trademarks of respective manufacturers listed. iPod, iPhone, and iTunes are trademarks of Apple Inc., registered in the U.S. and other countries.

© 2011 Belkin International, Inc. All rights reserved. All trade names are registered trademarks of respective manufacturers

listed. iPod, iPhone, and iTunes are trademarks of Apple Inc., registered in the U.S. and other countries.

© 2011 Belkin International, Inc. All rights reserved. All trade names are registered trademarks of respective manufacturers listed. iPod, iPhone, and iTunes are trademarks of Apple Inc., registered in the U.S. and other countries.