



FCC TEST REPORT

REPORT NO.: RF960718H04C

MODEL NO.: F5D8633-4

RECEIVED: Nov. 05, 2007

TESTED: Nov. 12 to 22, 2007

ISSUED: Nov. 26, 2007

APPLICANT: Belkin International, Inc.

ADDRESS: 501 West Walnut Street, Compton CA,
90220-5221, U.S.A.

ISSUED BY: Advance Data Technology Corporation

TEST LOCATION: No. 81-1, Lu Liao Keng, 9 Ling, Wu Lung
Tsuen, Chiung Lin Hsiang, Hsin Chu Hsien,
Taiwan, R.O.C.

This test report consists of 103 pages in total. It may be duplicated completely for legal use with the approval of the applicant. It should not be reproduced except in full, without the written approval of our laboratory. The client should not use it to claim product endorsement by TAF, A2LA or any government agencies. The test results in the report only apply to the tested sample.



No. 2177-01

Table of Contents

1.	CERTIFICATION	4
2.	SUMMARY OF TEST RESULTS	5
2.1	MEASUREMENT UNCERTAINTY	6
3.	GENERAL INFORMATION	7
3.1	GENERAL DESCRIPTION OF EUT	7
3.2	DESCRIPTION OF TEST MODES	9
3.2.1	TEST MODE APPLICABILITY AND TESTED CHANNEL DETAIL:	10
3.3	GENERAL DESCRIPTION OF APPLIED STANDARDS	13
3.4	DESCRIPTION OF SUPPORT UNITS	14
3.5	CONFIGURATION OF SYSTEM UNDER TEST	15
4.	TEST TYPES AND RESULTS	17
4.1	CONDUCTED EMISSION MEASUREMENT	17
4.1.1	LIMITS OF CONDUCTED EMISSION MEASUREMENT	17
4.1.2	TEST INSTRUMENTS	17
4.1.3	TEST PROCEDURES	18
4.1.4	DEVIATION FROM TEST STANDARD	18
4.1.5	TEST SETUP	19
4.1.6	EUT OPERATING CONDITIONS	19
4.1.7	TEST RESULTS	20
4.2	RADIATED EMISSION MEASUREMENT	22
4.2.1	LIMITS OF RADIATED EMISSION MEASUREMENT	22
4.2.2	TEST INSTRUMENTS	23
4.2.3	TEST PROCEDURES	24
4.2.4	DEVIATION FROM TEST STANDARD	24
4.2.5	TEST SETUP	25
4.2.6	EUT OPERATING CONDITIONS	25
	Below 1GHz Test Data	26
4.2.7	TEST RESULTS	26
	Above 1GHz Test Data	27
4.2.8	TEST RESULTS	27
4.3	6dB BANDWIDTH MEASUREMENT	55
4.3.1	LIMITS OF 6dB BANDWIDTH MEASUREMENT	55
4.3.2	TEST INSTRUMENTS	55
4.3.3	TEST PROCEDURE	56
4.3.4	DEVIATION FROM TEST STANDARD	56
4.3.5	TEST SETUP	56



4.3.6	EUT OPERATING CONDITIONS	56
4.3.7	TEST RESULTS	57
4.4	MAXIMUM PEAK OUTPUT POWER	69
4.4.1	LIMITS OF MAXIMUM PEAK OUTPUT POWER MEASUREMENT	69
4.4.2	INSTRUMENTS	69
4.4.3	TEST PROCEDURES	70
4.4.4	DEVIATION FROM TEST STANDARD	70
4.4.5	TEST SETUP	70
4.4.6	EUT OPERATING CONDITIONS	70
4.4.7	TEST RESULTS	71
4.5	POWER SPECTRAL DENSITY MEASUREMENT	73
4.5.1	LIMITS OF POWER SPECTRAL DENSITY MEASUREMENT	73
4.5.2	TEST INSTRUMENTS	73
4.5.3	TEST PROCEDURE	74
4.5.4	DEVIATION FROM TEST STANDARD	74
4.5.5	TEST SETUP	74
4.5.6	EUT OPERATING CONDITION	74
4.5.7	TEST RESULTS	75
4.6	BAND EDGES MEASUREMENT	87
4.6.1	LIMITS OF BAND EDGES MEASUREMENT	87
4.6.2	TEST INSTRUMENTS	87
4.6.3	TEST PROCEDURE	87
4.6.4	DEVIATION FROM TEST STANDARD	88
4.6.5	EUT OPERATING CONDITION	88
4.6.6	TEST RESULTS	88
4.7	ANTENNA REQUIREMENT	101
4.7.1	STANDARD APPLICABLE	101
4.7.2	ANTENNA CONNECTED CONSTRUCTION	101
5.	INFORMATION ON THE TESTING LABORATORIES	102
6.	APPENDIX-A- MODIFICATIONS RECORDERS FOR ENGINEERING CHANGES TO THE EUT BY THE LAB	103



1. CERTIFICATION

PRODUCT: N Wireless Modem Router
BRAND NAME: Belkin
MODEL NO.: F5D8633-4
TEST SAMPLE: R&D SAMPLE
TESTED: Nov. 12 to 22, 2007
APPLICANT: Belkin International, Inc.
STANDARDS: FCC Part 15, Subpart C (Section 15.247),
ANSI C63.4-2003

The above equipment (Model: F5D8633-4) has been tested by **Advance Data Technology Corporation**, and found compliance with the requirement of the above standards. The test record, data evaluation & Equipment Under Test (EUT) configurations represented herein are true and accurate accounts of the measurements of the sample's EMC characteristics under the conditions specified in this report.

PREPARED BY : Midoli Peng , **DATE:** Nov. 26, 2007
(Midoli Peng, Specialist)

TECHNICAL ACCEPTANCE : Hank Chung , **DATE:** Nov. 26, 2007
Responsible for RF (Hank Chung, Deputy Manager)

APPROVED BY : May Chen , **DATE:** Nov. 26, 2007
(May Chen, Deputy Manager)

2. SUMMARY OF TEST RESULTS

The EUT has been tested according to the following specifications:

APPLIED STANDARD: FCC Part 15, Subpart C (Section 15.247)			
Standard Section	Test Type and Limit	Result	Remark
15.207	AC Power Conducted Emission	PASS	Meet the requirement of limit. Minimum passing margin is -8.12dB at 0.185MHz
15.247(a)(2)	Spectrum Bandwidth of a Direct Sequence Spread Spectrum System Limit: min. 500kHz	PASS	Meet the requirement of limit.
15.247(b)	Maximum Peak Output Power Limit: max. 30dBm	PASS	Meet the requirement of limit.
15.247(d)	Radiated Emissions Limit: Table 15.209	PASS	Meet the requirement of limit. Minimum passing margin is -0.66dB at 2484.00MHz
15.247(e)	Power Spectral Density Limit: max. 8dBm	PASS	Meet the requirement of limit.
15.247(d)	Band Edge Measurement Limit: 20dB less than the peak value of fundamental frequency	PASS	Meet the requirement of limit.

2.1 MEASUREMENT UNCERTAINTY

Where relevant, the following measurement uncertainty levels have been estimated for tests performed on the EUT as specified in CISPR 16-4:

This uncertainty represents an expanded uncertainty expressed at approximately the 95% confidence level using a coverage factor of $k=2$.

Measurement	Value
Conducted emissions	2.44 dB
Radiated emissions (30MHz-1GHz)	3.94 dB
Radiated emissions (1GHz -18GHz)	2.33 dB
Radiated emissions (18GHz -40GHz)	2.557 dB

3. GENERAL INFORMATION

3.1 GENERAL DESCRIPTION OF EUT

PRODUCT	N Wireless Modem Router
MODEL NO.	F5D8633-4
FCC ID	K7SF5D8633-4A
POWER SUPPLY	DC 15V from power adapter
MODULATION TYPE	CCK, DQPSK, DBPSK for DSSS 64QAM, 16QAM, QPSK, BPSK for OFDM
MODULATION TECHNOLOGY	DSSS, OFDM
TRANSFER RATE	802.11b: 11 / 5.5 / 2 / 1Mbps 802.11g: 54 / 48 / 36 / 24 / 18 / 12 / 9 / 6Mbps Draft 802.11n (20MHz): 130 / 117 / 104 / 78 / 65 / 58.5 / 52 / 39 / 26 / 19.5 / 13 / 6.5Mbps Draft 802.11n (40MHz): 270 / 243 / 216 / 162 / 135 / 121.5 / 108 / 81 / 54 / 40.5 / 27 / 13.5Mbps
FREQUENCY RANGE	802.11b & 802.11g: 2412 ~ 2462MHz
NUMBER OF CHANNEL	11 for 802.11b, 802.11g, draft 802.11n (20MHz) 7 for draft 802.11n (40MHz)
MAXIMUM OUTPUT POWER	802.11b: 118.850mW 802.11g: 105.925mW draft 802.11n (20MHz): 186.700mW draft 802.11n (40MHz): 147.510mW
ANTENNA TYPE	Please see note 1
DATA CABLE	NA
I/O PORT	ADSL Port x 1, LAN Port x 4

NOTE:

- There are two antennas provided to this EUT, please refer to the following table:

No.	Antenna Type	Gain (dBi)	Antenna Connector
1	Dipole	2	NA
2	Dipole	2	NA

2. The EUT incorporates a MIMO function with 802.11b, 802.11g, draft 802.11n. Physically, the card provides two completed transmit and two completed receivers.
3. The EUT is 2 * 2 spatial MIMO without beam forming function. The antenna configurations are two transmitter antennas and two receiver antennas, as there are 2 dipole antennas. Spatial multiplexing modes for simultaneous transmission using 2 antennas, and for simultaneous receiver using 2 antennas.
4. When the EUT operating in draft 802.11n, the software operation, which is defined by manufacturer, MCS (Modulation and Coding Schemes) from 0 to 15.
5. The EUT complies with draft 802.11n standards and backwards compatible with 802.11b, 802.11g products.
6. The EUT operates in the 2.4GHz frequency spectrum with data rate up to 270Mbps.
7. The EUT must be supplied with a power adapter as following:

Brand:	Leader
Model No.:	481508003CT
Input power :	AC120, 220mA, 60Hz
Output power :	15VDC, 0.8A Cable : unshielded , 1.6m

8. The EUT, operates in the 2.4GHz frequency range, lets you connect IEEE 802.11g or IEEE 802.11b and draft 802.11n technique devices to the network.
9. The above EUT information was declared by manufacturer and for more detailed features description, please refer to the manufacturer's specifications or user's manual.

3.2 DESCRIPTION OF TEST MODES

Eleven channels are provided for 802.11b, 802.11g, draft 802.11n (20MHz):

CHANNEL	FREQUENCY	CHANNEL	FREQUENCY
1	2412MHz	7	2442MHz
2	2417MHz	8	2447MHz
3	2422MHz	9	2452MHz
4	2427MHz	10	2457MHz
5	2432MHz	11	2462MHz
6	2437MHz		

Seven channels are provided for draft 802.11n (40MHz):

CHANNEL	FREQUENCY	CHANNEL	FREQUENCY
1	2422MHz	5	2442MHz
2	2427MHz	6	2447MHz
3	2432MHz	7	2452MHz
4	2437MHz		

3.2.1 TEST MODE APPLICABILITY AND TESTED CHANNEL DETAIL:

EUT CONFIGURE MODE	APPLICABLE TO				DESCRIPTION
	PLC	RE < 1G	RE ≥ 1G	APCM	
-	√	√	√	√	-

Where **PLC**: Power Line Conducted Emission

RE < 1G: Radiated Emission below 1GHz

RE ≥ 1G: Radiated Emission above 1GHz

APCM: Antenna Port Conducted Measurement

ANTENNA COMBINATION MODE:

COMBINATION MODE	OPERATION MODE	ANTENNA 1	ANTENNA 2
A	802.11 b	√	
B			√
C	802.11g	√	
D			√
E	DRAFT 802.11n(20MHz)	√	√
F	DRAFT 802.11n(40MHz)	√	√

Note:

1. The above information was declared by manufacturer and for more detailed features description, please refer to the manufacturer's specifications or user's manual.
2. Antenna 1 and Antenna 2 are Dipole.
3. We choose the worst mode (decided by pre-test) for final test. Mode A, C, E and F the worst modes, was selected as representative mode for this report.

POWER LINE CONDUCTED EMISSION TEST:

- Pre-Scan has been conducted to determine the worst-case mode from all possible combinations between available modulations, data rates and antenna ports (if EUT with antenna diversity architecture).
- Following channel(s) was (were) selected for the final test as listed below.

MODE	AVAILABLE CHANNEL	TESTED CHANNEL	MODULATION TECHNOLOGY	MODULATION TYPE	DATA RATE (Mbps)	TX COMBINATION
802.11b	1 to 11	1	DSSS	DBPSK	1	A

RADIATED EMISSION TEST (BELOW 1 GHz):

- Pre-Scan has been conducted to determine the worst-case mode from all possible combinations between available modulations, data rates and antenna ports (if EUT with antenna diversity architecture).
- Following channel(s) was (were) selected for the final test as listed below.

MODE	AVAILABLE CHANNEL	TESTED CHANNEL	MODULATION TECHNOLOGY	MODULATION TYPE	DATA RATE (Mbps)	TX COMBINATION
802.11b	1 to 11	1	DSSS	DBPSK	1	A

RADIATED EMISSION TEST (ABOVE 1 GHz):

- Pre-Scan has been conducted to determine the worst-case mode from all possible combinations between available modulations, data rates and antenna ports (if EUT with antenna diversity architecture).
- Following channel(s) was (were) selected for the final test as listed below.

MODE	AVAILABLE CHANNEL	TESTED CHANNEL	MODULATION TECHNOLOGY	MODULATION TYPE	DATA RATE (Mbps)	TX COMBINATION
802.11b	1 to 11	1, 6, 11	DSSS	DBPSK	1	A
802.11g	1 to 11	1, 6, 11	OFDM	BPSK	6	C
Draft 802.11n (20MHz)	1 to 11	1, 6, 11	OFDM	BPSK	6.5	E
Draft 802.11n (40MHz)	1 to 7	1, 4, 7	OFDM	BPSK	13.5	F

BANDEDGE MEASUREMENT:

- Pre-Scan has been conducted to determine the worst-case mode from all possible combinations between available modulations, data rates and antenna ports (if EUT with antenna diversity architecture).
- Following channel(s) was (were) selected for the final test as listed below.

MODE	AVAILABLE CHANNEL	TESTED CHANNEL	MODULATION TECHNOLOGY	MODULATION TYPE	DATA RATE (Mbps)	TX COMBINATION
802.11b	1 to 11	1, 11	DSSS	DBPSK	1	A
802.11g	1 to 11	1, 11	OFDM	BPSK	6	C
Draft 802.11n (20MHz)	1 to 11	1, 11	OFDM	BPSK	6.5	E
Draft 802.11n (40MHz)	1 to 7	1, 7	OFDM	BPSK	13.5	F

ANTENNA PORT CONDUCTED MEASUREMENT:

- Pre-Scan has been conducted to determine the worst-case mode from all possible combinations between available modulations, data rates and antenna ports (if EUT with antenna diversity architecture).
- Following channel(s) was (were) selected for the final test as listed below.

MODE	AVAILABLE CHANNEL	TESTED CHANNEL	MODULATION TECHNOLOGY	MODULATION TYPE	DATA RATE (Mbps)	TX COMBINATION
802.11b	1 to 11	1, 6, 11	DSSS	CCK	11	A
802.11g	1 to 11	1, 6, 11	OFDM	BPSK	6	C
Draft 802.11n (20MHz)	1 to 11	1, 6, 11	OFDM	BPSK	6.5	E
Draft 802.11n (40MHz)	1 to 7	1, 4, 7	OFDM	BPSK	13.5	F



3.3 GENERAL DESCRIPTION OF APPLIED STANDARDS

The EUT is an N Wireless Modem Router. According to the specifications of the manufacturer, it must comply with the requirements of the following standards:

FCC Part 15, Subpart C. (15.247)

ANSI C63.4-2003

All test items have been performed and recorded as per the above standards.

NOTE: The EUT is also considered as a kind of computer peripheral, because the connection to computer is necessary for typical use. It has been verified to comply with the requirements of FCC Part 15, Subpart B, Class B (DoC). The test report has been issued separately.



3.4 DESCRIPTION OF SUPPORT UNITS

The EUT has been tested as an independent unit together with other necessary accessories or support units. The following support units or accessories were used to form a representative test configuration during the tests.

NO.	PRODUCT	BRAND	MODEL NO.	SERIAL NO.	FCC ID
1	NOTEBOOK COMPUTER	DELL	PP18L	6976685584	DoC
2	NOTEBOOK COMPUTER	HP	HSTNN-S19C	WFY93-WQ98K-BH 87F-KD366-RB773	DoC
3	NOTEBOOK COMPUTER	DELL	PP19L	CN-OHC416-70166- 5CA-0448	DoC
4	CO-ROUTER	ZyXEL	IES-1000	S4Z3112558	NA
5	Switch HUB	AVSYS	110H8	01-20E-000006	DoC

NO.	SIGNAL CABLE DESCRIPTION OF THE ABOVE SUPPORT UNITS
1	NA
2	NA
3	NA
4	NA
5	NA

NOTE: All power cords of the above support units are non shielded (1.8m).

3.5 CONFIGURATION OF SYSTEM UNDER TEST

For Conducted test:

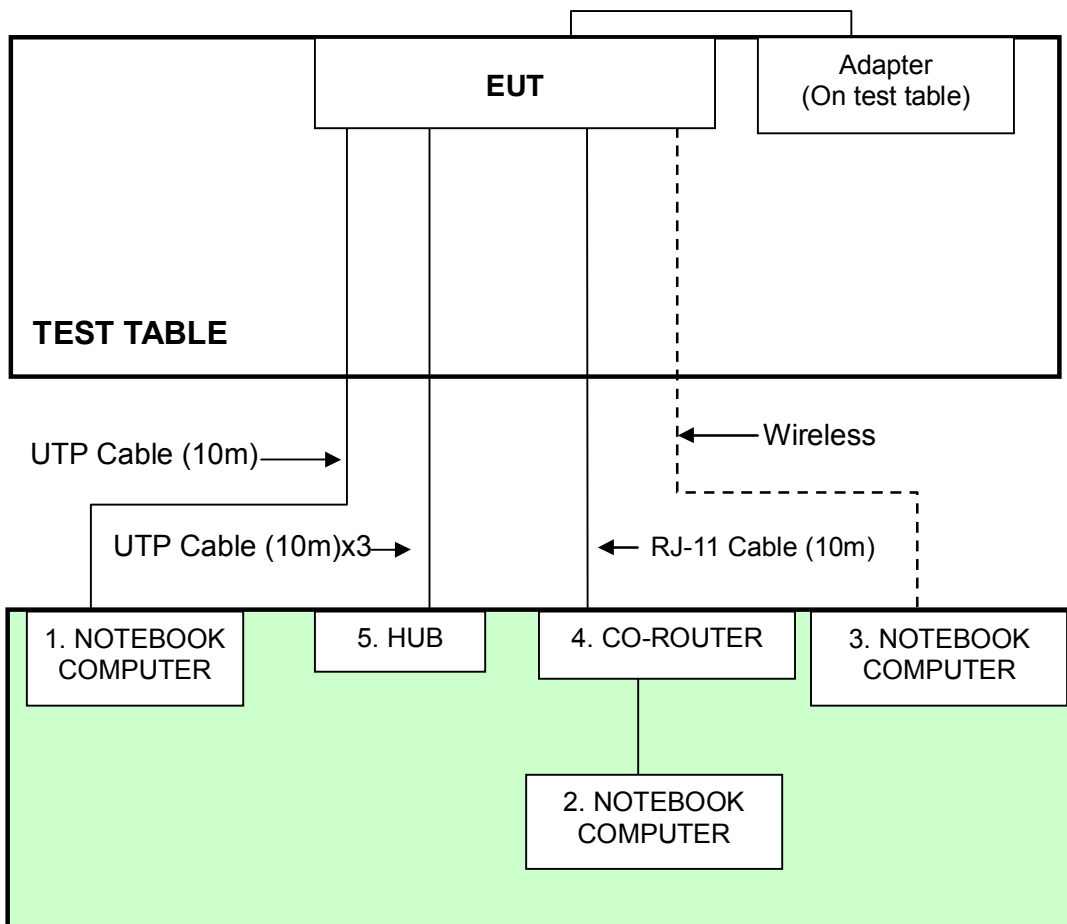

NOTE: 1. Support units 1-5 were kept in the control room during the test.

For Other test:

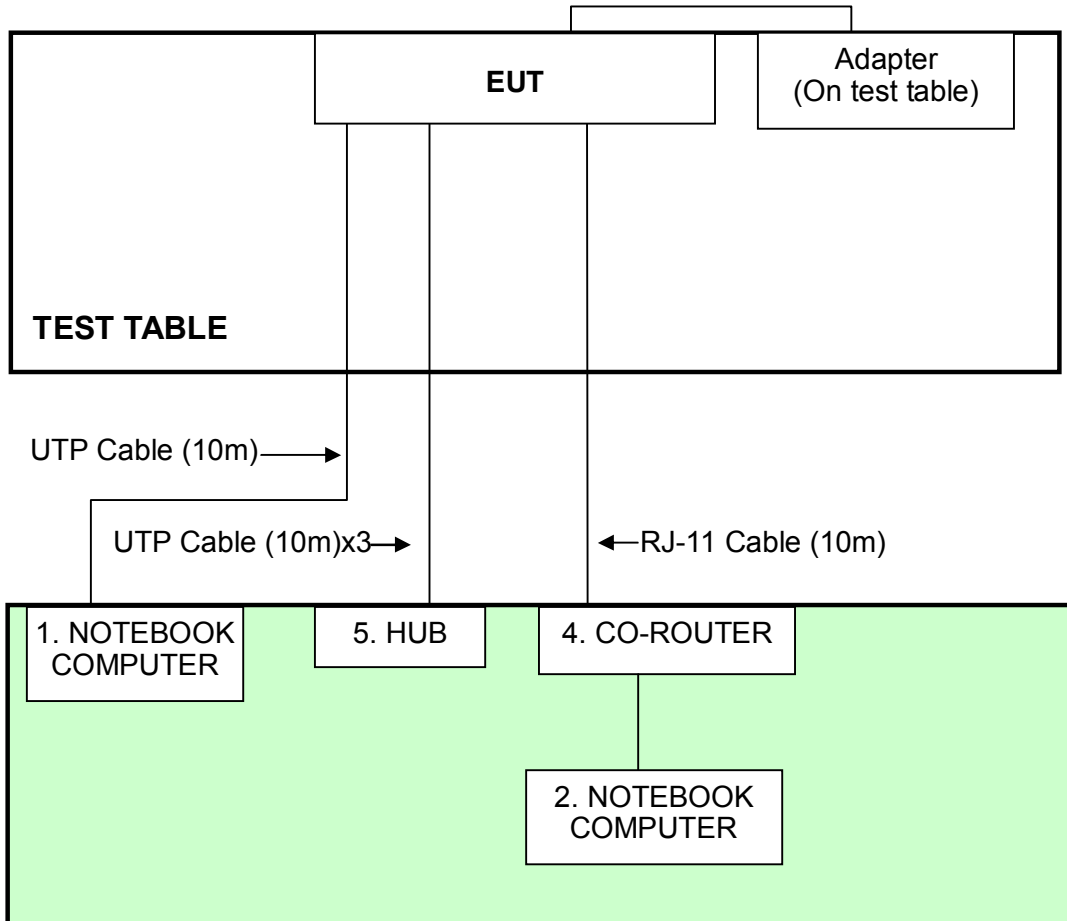

NOTE: 1. Support units 1-2, 4-5 were kept in the control room during the test.

4. TEST TYPES AND RESULTS

4.1 CONDUCTED EMISSION MEASUREMENT

4.1.1 LIMITS OF CONDUCTED EMISSION MEASUREMENT

FREQUENCY OF EMISSION (MHz)	CONDUCTED LIMIT (dB μ V)	
	Quasi-peak	Average
0.15-0.5	66 to 56	56 to 46
0.5-5	56	46
5-30	60	50

- NOTE:**
1. The lower limit shall apply at the transition frequencies.
 2. The limit decreases in line with the logarithm of the frequency in the range of 0.15 to 0.50 MHz.
 3. All emanations from a class A/B digital device or system, including any network of conductors and apparatus connected thereto, shall not exceed the level of field strengths specified above.

4.1.2 TEST INSTRUMENTS

DESCRIPTION & MANUFACTURER	MODEL NO.	SERIAL NO.	CALIBRATED UNTIL
Test Receiver	ESCS 30	847124/029	Mar. 28, 2008
Line-Impedance Stabilization Network(for EUT)	ENV-216	100071	Nov. 26, 2008
Line-Impedance Stabilization Network(for Peripheral)	ESH3-Z5	848773/004	Nov. 08, 2008
RF Cable (JETBAO)	RG233/U	Cable_CB_01	Dec. 09, 2007
Terminator	50	2	Oct. 30, 2008
Software	ADT_Cond_V7.3.2	NA	NA

- NOTE:**
1. The calibration interval of the above test instruments is 12 months and the calibrations are traceable to NML/ROC and NIST/USA.
 2. The test was performed in ADT Shielded Room No. B.
 3. The VCCI Con B Registration No. is C-2193.

4.1.3 TEST PROCEDURES

- a. The EUT was placed 0.4 meters from the conducting wall of the shielded room with EUT being connected to the power mains through a line impedance stabilization network (LISN). Other support units were connected to the power mains through another LISN. The two LISNs provide 50 ohm/ 50uH of coupling impedance for the measuring instrument.
- b. Both lines of the power mains connected to the EUT were checked for maximum conducted interference.
- c. The frequency range from 150kHz to 30MHz was searched. Emission levels under (Limit - 20dB) were not recorded.

4.1.4 DEVIATION FROM TEST STANDARD

No deviation

4.1.5 TEST SETUP

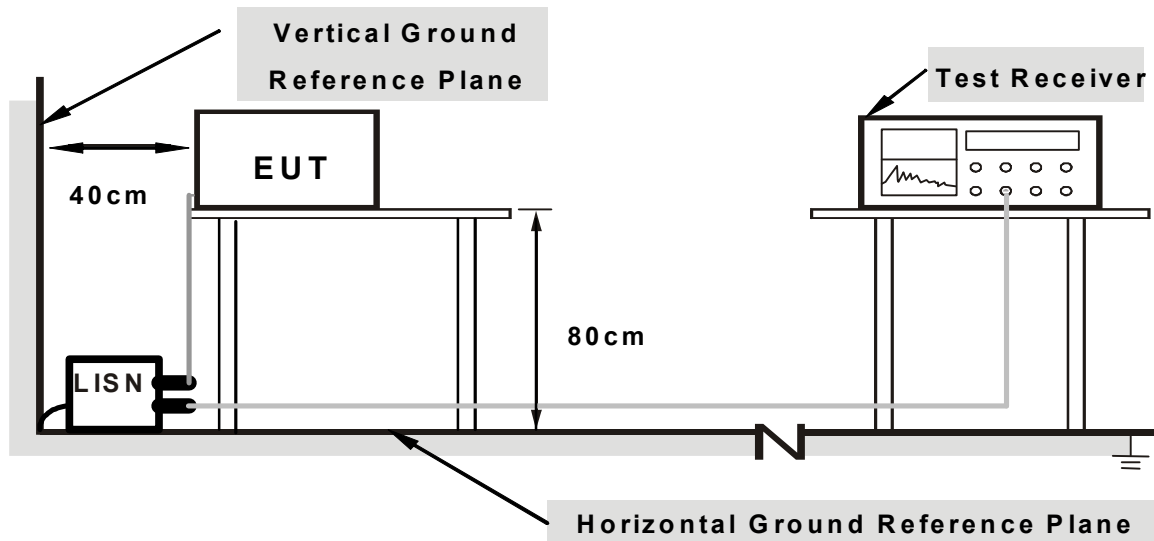

Note: 1. Support units were connected to second LISN.

2. Both of LISNs (AMN) are 80 cm from EUT and at least 80 from other units and other metal planes

For the actual test configuration, please refer to the related item – Photographs of the Test Configuration.

4.1.6 EUT OPERATING CONDITIONS

1. Placed the EUT on testing table.
2. Prepared other computer systems (support unit 1 ~ 4) to act as communication partners and placed them outside of testing area.
3. The communication partners run test program “Ping Test & ArcMfgTool 2.0.0.9” to enable EUT under transmission/receiving condition continuously via UTP cables, RJ11 cable and wireless transmission.

4.1.7 TEST RESULTS

802.11b DSSS MODULATION:

EUT TEST CONDITION		MEASUREMENT DETAIL	
CHANNEL	Channel 1	PHASE	Line (L)
MODULATION TYPE	CCK	6dB BANDWIDTH	9 kHz
TRANSFER RATE	1Mbps	INPUT POWER (SYSTEM)	120Vac, 60 Hz
ENVIRONMENTAL CONDITIONS	23deg. C, 56%RH, 955hPa	TESTED BY	Wen Yu

No	Freq. [MHz]	Corr. Factor (dB)	Reading Value		Emission Level		Limit		Margin	
			[dB (uV)]		[dB (uV)]		[dB (uV)]		(dB)	
			Q.P.	AV.	Q.P.	AV.	Q.P.	AV.	Q.P.	AV.
1	0.150	0.40	57.32	31.76	57.72	32.16	66.00	56.00	-8.28	-23.84
2	0.185	0.40	56.09	33.11	56.49	33.51	64.25	54.25	-7.76	-20.74
3	0.236	0.40	53.12	23.86	53.52	24.26	62.24	52.24	-8.72	-27.98
4	0.466	0.40	44.82	-	45.22	-	56.58	46.58	-11.36	-
5	0.912	0.40	37.63	-	38.03	-	56.00	46.00	-17.97	-
6	15.071	1.10	45.55	-	46.65	-	60.00	50.00	-13.35	-

- REMARKS:**
1. Q.P. and AV. are abbreviations of quasi-peak and average individually.
 2. "-": The Quasi-peak reading value also meets average limit and measurement with the average detector is unnecessary.
 3. The emission levels of other frequencies were very low against the limit.
 4. Margin value = Emission level - Limit value
 5. Correction factor = Insertion loss + Cable loss
 6. Emission Level = Correction Factor + Reading Value.

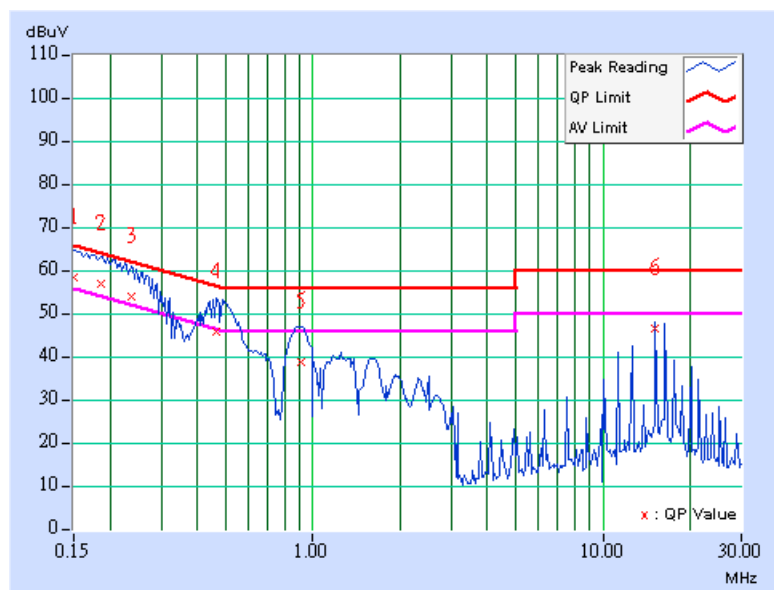

EUT TEST CONDITION		MEASUREMENT DETAIL	
CHANNEL	Channel 1	PHASE	Neutral (N)
MODULATION TYPE	CCK	6dB BANDWIDTH	9 kHz
TRANSFER RATE	1Mbps	INPUT POWER (SYSTEM)	120Vac, 60 Hz
ENVIRONMENTAL CONDITIONS	20deg. C, 62%RH, 955hPa	TESTED BY	Sky Liao

No	Freq. [MHz]	Corr. Factor (dB)	Reading Value [dB (uV)]		Emission Level [dB (uV)]		Limit [dB (uV)]		Margin (dB)	
			Q.P.	AV.	Q.P.	AV.	Q.P.	AV.	Q.P.	AV.
	1	0.150	0.20	57.30	31.02	57.50	31.22	66.00	56.00	-8.50
2	0.185	0.20	55.93	32.54	56.13	32.74	64.25	54.25	-8.12	-21.51
3	0.259	0.20	51.55	21.40	51.75	21.60	61.45	51.45	-9.70	-29.85
4	0.463	0.21	43.80	-	44.01	-	56.65	46.65	-12.64	-
5	0.865	0.28	35.02	-	35.30	-	56.00	46.00	-20.70	-
6	16.358	1.23	44.27	-	45.50	-	60.00	50.00	-14.50	-

- REMARKS:**
1. Q.P. and AV. are abbreviations of quasi-peak and average individually.
 2. "-": The Quasi-peak reading value also meets average limit and measurement with the average detector is unnecessary.
 3. The emission levels of other frequencies were very low against the limit.
 4. Margin value = Emission level - Limit value
 5. Correction factor = Insertion loss + Cable loss
 6. Emission Level = Correction Factor + Reading Value.

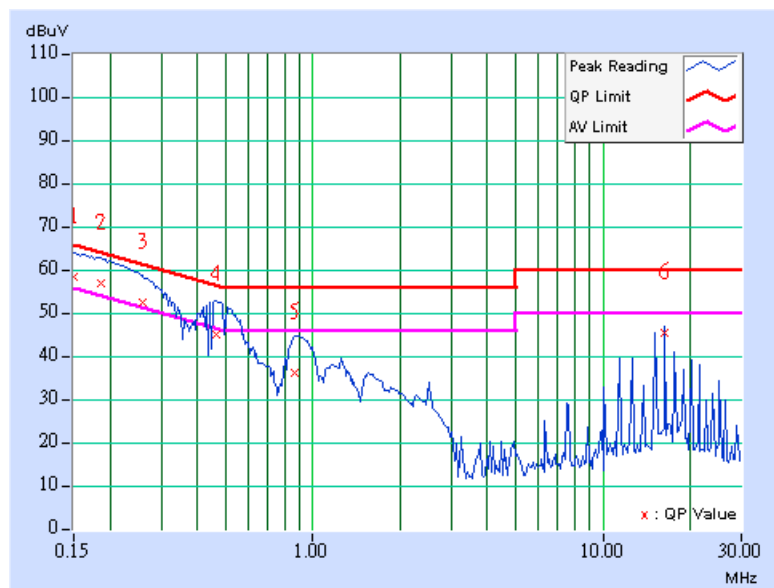

4.2 RADIATED EMISSION MEASUREMENT

4.2.1 LIMITS OF RADIATED EMISSION MEASUREMENT

Emissions radiated outside of the specified bands, shall be according to the general radiated limits in 15.209 as following:

Frequencies (MHz)	Field strength (microvolts/meter)	Measurement distance (meters)
0.009-0.490	2400/F(kHz)	300
0.490-1.705	24000/F(kHz)	30
1.705-30.0	30	30
30-88	100	3
88-216	150	3
216-960	200	3
Above 960	500	3

NOTE:

1. The lower limit shall apply at the transition frequencies.
2. Emission level (dBuV/m) = 20 log Emission level (uV/m).
3. As shown in 15.35(b), for frequencies above 1000MHz, the field strength limits are based on average detector, however, the peak field strength of any emission shall not exceed the maximum permitted average limits, specified above by more than 20dB under any condition of modulation.



4.2.2 TEST INSTRUMENTS

DESCRIPTION & MANUFACTURER	MODEL NO.	SERIAL NO.	CALIBRATED UNTIL
ADVANTEST Spectrum Analyzer	R3271A	85060311	July 15, 2008
HP Pre_Amplifier	8449B	3008A01922	Oct. 04, 2008
ROHDE & SCHWARZ Test Receiver	ESCS30	100375	Mar. 26, 2008
CHASE Broadband Antenna	VULB 9168	138	July 26, 2008
Schwarzbeck Horn_Antenna	BBHA9120	D124	Jan. 01, 2008
Schwarzbeck Horn_Antenna	BBHA 9170	BBHA9170153	Jan. 25, 2008
TRILOG Broad Band Antenna	VULB 9168	138	July 26, 2008
RF Switches (ARNITSU)	CS-201	1565157	Aug. 13, 2008
RF CABLE (Chaintek)	SF102	22054-2	Nov. 14. 2008
RF Cable(RICHTEC)	9913-30M N-N Cable	STCCAB-30M-1 GHz	Aug. 13, 2008
Software	ADT_Radiated_V 7.6.15.7	NA	NA
CHANCE MOST Antenna Tower	AT-100	0203	NA
CHANCE MOST Turn Table	TT-100	0203	NA

- Note: 1. The calibration interval of the above test instruments is 12 months and the calibrations are traceable to NML/ROC and NIST/USA.
 2. The horn antenna, HP preamplifier (model: 8449B) and Spectrum Analyzer (model: R3271A) are used only for the measurement of emission frequency above 1GHz if tested.
 3. The test was performed in ADT Open Site No. C.
 4. The FCC Site Registration No. is 656396.
 5. The VCCI Site Registration No. is R-1626.
 6. The CANADA Site Registration No. is IC 4824A-3.

4.2.3 TEST PROCEDURES

- a. The EUT was placed on the top of a rotating table 0.8 meters above the ground at a 3 meter semi- anechoic. The table was rotated 360 degrees to determine the position of the highest radiation.
- b. The EUT was set 3 meters away from the interference-receiving antenna, which was mounted on the top of a variable-height antenna tower.
- c. The antenna is a broadband antenna, and its height is varied from one meter to four meters above the ground to determine the maximum value of the field strength. Both horizontal and vertical polarizations of the antenna are set to make the measurement.
- d. For each suspected emission, the EUT was arranged to its worst case and then the antenna was tuned to heights from 1 meter to 4 meters and the rotatable table was turned from 0 degrees to 360 degrees to find the maximum reading.
- e. The test-receiver system was set to Peak Detect Function and Specified Bandwidth with Maximum Hold Mode.
- f. If the emission level of the EUT in peak mode was 10 dB lower than the limit specified, then testing could be stopped and the peak values of the EUT would be reported. Otherwise the emissions that did not have 10 dB margin would be re-tested one by one using the quasi-peak method or average method as specified and then reported in Data sheet peak mode and QP mode.

NOTE:

1. The resolution bandwidth and video bandwidth of test receiver/spectrum analyzer is 120kHz for Peak detection (PK) and Quasi-peak detection (QP) at frequency below 1GHz.
2. The resolution bandwidth of test receiver/spectrum analyzer is 1 MHz and the video bandwidth is 3 MHz for Peak detection (PK) at frequency above 1GHz.
3. The resolution bandwidth of test receiver/spectrum analyzer is 1 MHz and the video bandwidth is 10 Hz for Average detection (AV) at frequency above 1GHz.

4.2.4 DEVIATION FROM TEST STANDARD

No deviation

4.2.5 TEST SETUP

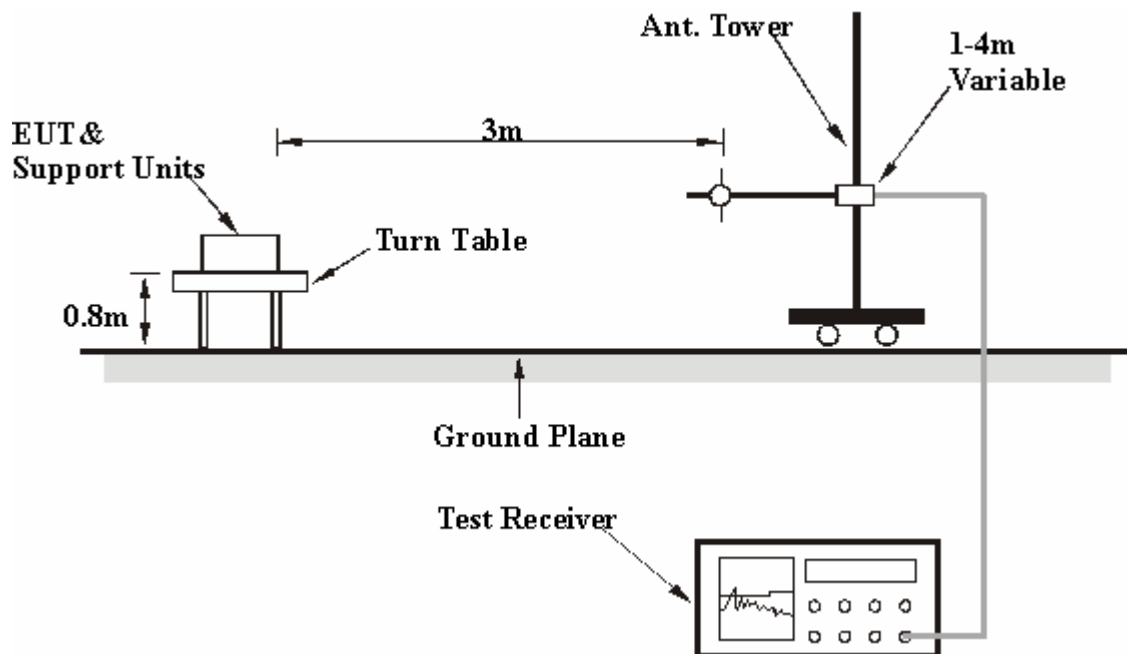

For the actual test configuration, please refer to the related item – Photographs of the Test Configuration.

4.2.6 EUT OPERATING CONDITIONS

1. Placed the EUT on testing table.
2. Prepared other computer systems (support unit 1 ~ 2&4) to act as communication partners and placed them outside of testing area.
3. The communication partners run test program “ArcMfgTool 2.0.0.9” to enable EUT under transmission/receiving condition continuously via UTP cables, RJ11 cable.

Below 1GHz Test Data

4.2.7 TEST RESULTS

EUT TEST CONDITION		MEASUREMENT DETAIL	
CHANNEL	Channel 1	FREQUENCY RANGE	Below 1000MHz
MODULATION TYPE	802.11b	INPUT POWER (SYSTEM)	120Vac, 60 Hz
TRANSFER RATE	1Mbps	DETECTOR FUNCTION	Quasi-Peak
ENVIRONMENTAL CONDITIONS	26deg. C, 64%RH, 955hPa	TESTED BY	Sky Liao

ANTENNA POLARITY & TEST DISTANCE: HORIZONTAL AT 10 M								
No.	Freq. (MHz)	Emission Level (dBuV/m)	Limit (dBuV/m)	Margin (dB)	Antenna Height (m)	Table Angle (Degree)	Raw Value (dBuV)	Correction Factor (dB/m)
1	250.01	36.12 QP	46.00	-9.88	1.16 H	161	23.29	12.83
2	325.00	31.69 QP	46.00	-14.31	1.00 H	26	14.94	16.75
3	375.00	29.25 QP	46.00	-16.75	1.01 H	4	11.77	17.48
4	400.01	32.19 QP	46.00	-13.81	1.16 H	272	14.14	18.05
5	500.01	31.01 QP	46.00	-14.99	1.16 H	316	9.96	21.05
6	575.01	30.61 QP	46.00	-15.39	1.16 H	236	8.40	22.21
7	600.01	31.60 QP	46.00	-14.40	1.53 H	16	8.06	23.54
8	700.01	32.64 QP	46.00	-13.36	1.55 H	35	8.12	24.52
9	800.01	37.52 QP	46.00	-8.48	1.00 H	21	9.47	28.05
10	900.00	36.22 QP	46.00	-9.78	1.05 H	56	6.55	29.67

ANTENNA POLARITY & TEST DISTANCE: VERTICAL AT 3 M								
No.	Freq. (MHz)	Emission Level (dBuV/m)	Limit (dBuV/m)	Margin (dB)	Antenna Height (m)	Table Angle (Degree)	Raw Value (dBuV)	Correction Factor (dB/m)
1	125.00	26.71 QP	43.50	-16.79	1.00 V	21	13.48	13.23
2	250.00	40.57 QP	46.00	-5.43	1.00 V	289	27.74	12.83
3	375.00	26.17 QP	46.00	-19.83	1.00 V	1	8.69	17.48
4	400.00	32.17 QP	46.00	-13.83	1.28 V	125	14.12	18.05
5	500.00	33.58 QP	46.00	-12.42	1.00 V	325	12.53	21.05
6	575.00	31.30 QP	46.00	-14.70	1.00 V	150	9.09	22.21
7	600.00	29.78 QP	46.00	-16.22	1.48 V	153	6.24	23.54
8	700.00	30.56 QP	46.00	-15.44	1.33 V	1	6.04	24.52
9	800.00	36.26 QP	46.00	-9.74	1.16 V	1	8.21	28.05
10	900.00	33.79 QP	46.00	-12.21	1.00 V	21	4.12	29.67

- REMARKS:**
1. Emission level (dBuV/m) = Raw Value (dBuV) + Correction Factor (dB/m).
 2. Correction Factor (dB/m) = Antenna Factor (dB/m) + Cable Factor (dB).
 3. The other emission levels were very low against the limit.
 4. Margin value = Emission level – Limit value.

Above 1GHz Test Data

4.2.8 TEST RESULTS

802.11b DSSS MODULATION:

EUT TEST CONDITION		MEASUREMENT DETAIL	
CHANNEL	Channel 1	FREQUENCY RANGE	1 ~ 25GHz
MODULATION TYPE	CCK	INPUT POWER (SYSTEM)	120Vac, 60 Hz
TRANSFER RATE	1Mbps	DETECTOR FUNCTION	Peak(PK) Average (AV)
ENVIRONMENTAL CONDITIONS	20deg. C, 70%RH, 955hPa	TESTED BY	Rex Huang

ANTENNA POLARITY & TEST DISTANCE: HORIZONTAL AT 3 M

No.	Freq. (MHz)	Emission Level (dBuV/m)	Limit (dBuV/m)	Margin (dB)	Antenna Height (m)	Table Angle (Degree)	Raw Value (dBuV)	Correction Factor (dB/m)
1	2386.32	55.57 PK	74.00	-18.43	1.48 H	21	25.19	30.38
2	2386.32	44.74 AV	54.00	-9.26	1.48 H	21	14.36	30.38
3	*2412.00	98.40 PK			1.48 H	20	67.91	30.49
4	*2412.00	92.80 AV			1.48 H	20	62.31	30.49
5	4824.00	49.80 PK	74.00	-24.20	1.64 H	64	14.11	35.69
6	4824.00	44.20 AV	54.00	-9.80	1.64 H	64	8.51	35.69
7	7236.00	52.60 PK	74.00	-21.40	1.24 H	4	10.36	42.24
8	7236.00	39.20 AV	54.00	-14.80	1.24 H	4	-3.04	42.24

ANTENNA POLARITY & TEST DISTANCE: VERTICAL AT 3 M

No.	Freq. (MHz)	Emission Level (dBuV/m)	Limit (dBuV/m)	Margin (dB)	Antenna Height (m)	Table Angle (Degree)	Raw Value (dBuV)	Correction Factor (dB/m)
1	2386.00	61.32 PK	74.00	-12.68	1.00 V	100	30.94	30.38
2	2386.00	52.58 AV	54.00	-1.42	1.00 V	100	22.20	30.38
3	*2412.00	109.50 PK			1.68 V	118	79.01	30.49
4	*2412.00	104.50 AV			1.68 V	118	74.01	30.49
5	4824.00	51.80 PK	74.00	-22.20	1.46 V	164	16.11	35.69
6	4824.00	48.00 AV	54.00	-6.00	1.46 V	164	12.31	35.69
7	7236.00	53.00 PK	74.00	-21.00	1.32 V	164	10.76	42.24
8	7236.00	39.70 AV	54.00	-14.30	1.32 V	164	-2.54	42.24

- REMARKS:**
1. Emission level (dBuV/m) = Raw Value (dBuV) + Correction Factor (dB/m).
 2. Correction Factor (dB/m) = Antenna Factor (dB/m) + Cable Factor (dB).
 3. The other emission levels were very low against the limit.
 4. Margin value = Emission level – Limit value.
 5. The limit value is defined as per 15.247.
 6. “ * “: Fundamental frequency.

EUT TEST CONDITION		MEASUREMENT DETAIL	
CHANNEL	Channel 6	FREQUENCY RANGE	1 ~ 25GHz
MODULATION TYPE	CCK	INPUT POWER (SYSTEM)	120Vac, 60 Hz
TRANSFER RATE	1Mbps	DETECTOR FUNCTION	Peak(PK) Average (AV)
ENVIRONMENTAL CONDITIONS	20deg. C, 70%RH, 955hPa	TESTED BY	Rex Huang

ANTENNA POLARITY & TEST DISTANCE: HORIZONTAL AT 3 M

No.	Freq. (MHz)	Emission Level (dBuV/m)	Limit (dBuV/m)	Margin (dB)	Antenna Height (m)	Table Angle (Degree)	Raw Value (dBuV)	Correction Factor (dB/m)
1	*2437.00	99.40 PK			1.29 H	196	68.79	30.61
2	*2437.00	93.70 AV			1.29 H	196	63.09	30.61
3	4874.00	48.60 PK	74.00	-25.40	1.52 H	73	12.80	35.80
4	4874.00	43.70 AV	54.00	-10.30	1.52 H	73	7.90	35.80
5	7311.00	52.80 PK	74.00	-21.20	1.27 H	345	10.28	42.52
6	7311.00	39.60 AV	54.00	-14.40	1.27 H	345	-2.92	42.52

ANTENNA POLARITY & TEST DISTANCE: VERTICAL AT 3 M

No.	Freq. (MHz)	Emission Level (dBuV/m)	Limit (dBuV/m)	Margin (dB)	Antenna Height (m)	Table Angle (Degree)	Raw Value (dBuV)	Correction Factor (dB/m)
1	*2437.00	109.60 PK			1.69 V	89	78.99	30.61
2	*2437.00	105.20 AV			1.69 V	89	74.59	30.61
3	4874.00	51.20 PK	74.00	-22.80	1.26 V	87	15.40	35.80
4	4874.00	47.60 AV	54.00	-6.40	1.26 V	87	11.80	35.80
5	7311.00	53.30 PK	74.00	-20.70	1.34 V	178	10.78	42.52
6	7311.00	40.20 AV	54.00	-13.80	1.34 V	178	-2.32	42.52

- REMARKS:**
1. Emission level (dBuV/m) = Raw Value (dBuV) + Correction Factor (dB/m).
 2. Correction Factor (dB/m) = Antenna Factor (dB/m) + Cable Factor (dB).
 3. The other emission levels were very low against the limit.
 4. Margin value = Emission level – Limit value.
 5. The limit value is defined as per 15.247.
 6. “ * “: Fundamental frequency.

EUT TEST CONDITION		MEASUREMENT DETAIL	
CHANNEL	Channel 11	FREQUENCY RANGE	1 ~ 25GHz
MODULATION TYPE	CCK	INPUT POWER (SYSTEM)	120Vac, 60 Hz
TRANSFER RATE	1Mbps	DETECTOR FUNCTION	Peak(PK) Average (AV)
ENVIRONMENTAL CONDITIONS	20deg. C, 70%RH, 955hPa	TESTED BY	Rex Huang

ANTENNA POLARITY & TEST DISTANCE: HORIZONTAL AT 3 M

No.	Freq. (MHz)	Emission Level (dBuV/m)	Limit (dBuV/m)	Margin (dB)	Antenna Height (m)	Table Angle (Degree)	Raw Value (dBuV)	Correction Factor (dB/m)
1	*2462.00	98.60 PK			1.26 H	203	67.88	30.72
2	*2462.00	93.10 AV			1.26 H	203	62.38	30.72
3	2487.75	56.95 PK	74.00	-17.05	1.28 H	204	26.12	30.83
4	2487.75	45.46 AV	54.00	-8.54	1.28 H	204	14.63	30.83
5	4924.00	49.70 PK	74.00	-24.30	1.61 H	94	13.80	35.90
6	4924.00	44.30 AV	54.00	-9.70	1.61 H	94	8.40	35.90
7	7386.00	53.30 PK	74.00	-20.70	1.34 H	353	10.50	42.80
8	7386.00	40.10 AV	54.00	-13.90	1.34 H	353	-2.70	42.80

ANTENNA POLARITY & TEST DISTANCE: VERTICAL AT 3 M

No.	Freq. (MHz)	Emission Level (dBuV/m)	Limit (dBuV/m)	Margin (dB)	Antenna Height (m)	Table Angle (Degree)	Raw Value (dBuV)	Correction Factor (dB/m)
1	*2462.00	109.20 PK			1.60 V	90	78.48	30.72
2	*2462.00	104.80 AV			1.60 V	90	74.08	30.72
3	2487.82	63.02 PK	74.00	-10.98	1.60 V	90	32.18	30.84
4	2487.82	52.46 AV	54.00	-1.54	1.60 V	90	21.62	30.84
5	4924.00	52.10 PK	74.00	-21.90	1.36 V	84	16.20	35.90
6	4924.00	48.10 AV	54.00	-5.90	1.36 V	84	12.20	35.90
7	7386.00	54.50 PK	74.00	-19.50	1.56 V	164	11.70	42.80
8	7386.00	42.00 AV	54.00	-12.00	1.56 V	164	-0.80	42.80

- REMARKS:**
1. Emission level (dBuV/m) = Raw Value (dBuV) + Correction Factor (dB/m).
 2. Correction Factor (dB/m) = Antenna Factor (dB/m) + Cable Factor (dB).
 3. The other emission levels were very low against the limit.
 4. Margin value = Emission level – Limit value.
 5. The limit value is defined as per 15.247.
 6. “ * “: Fundamental frequency.

RESTRICTED BANDEDGE (802.11b MODE, CH1, HORIZONTAL)

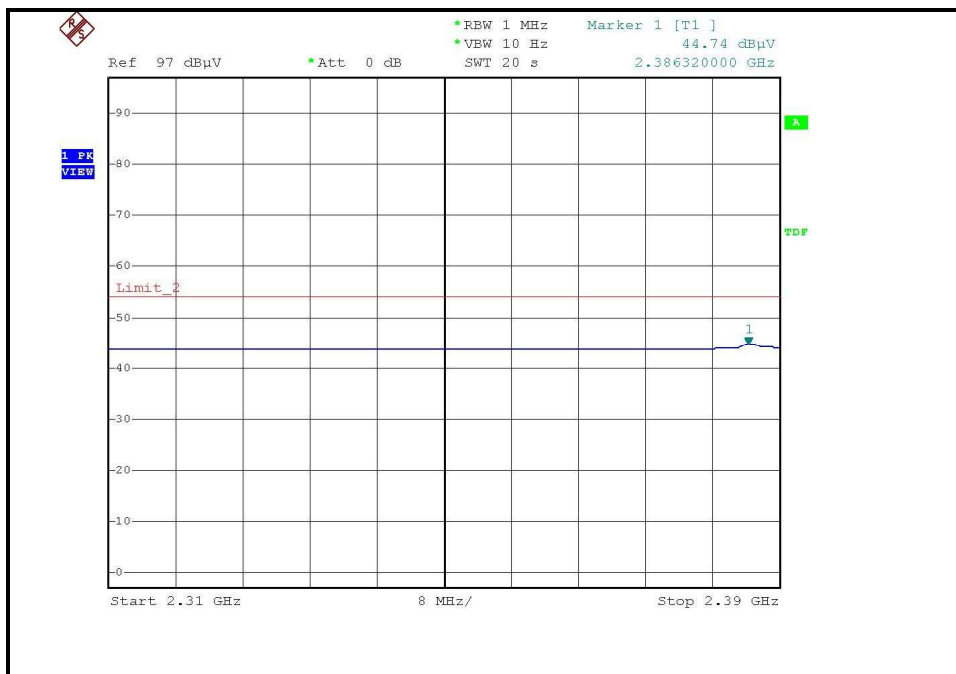
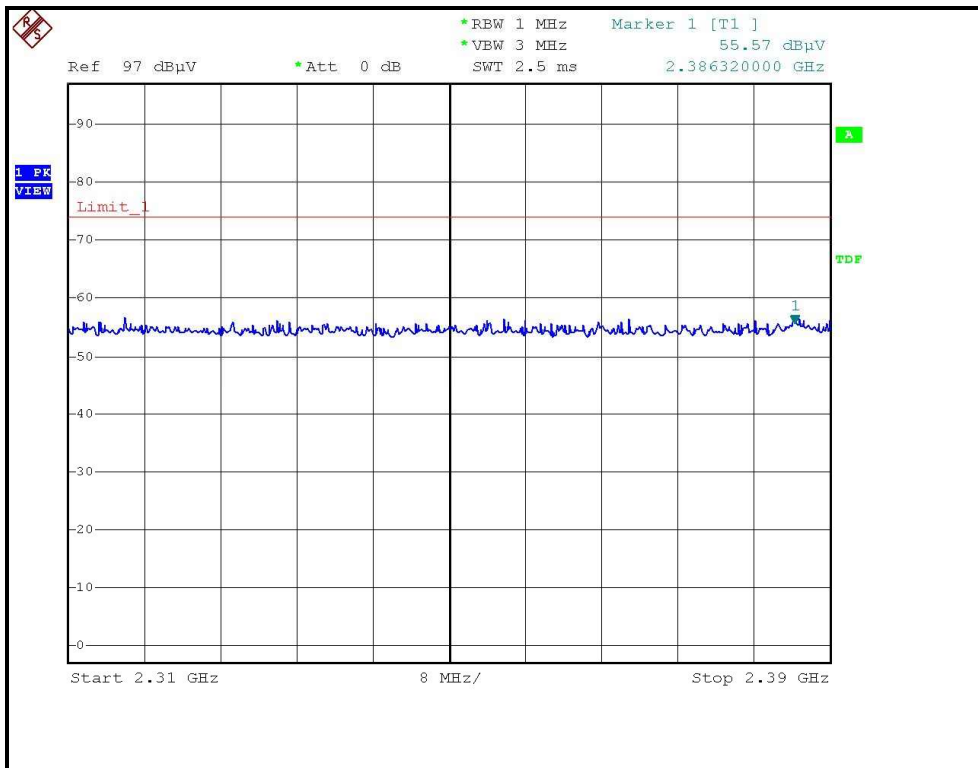

RESTRICTED BANDEDGE (802.11b MODE, CH1, VERTICAL)

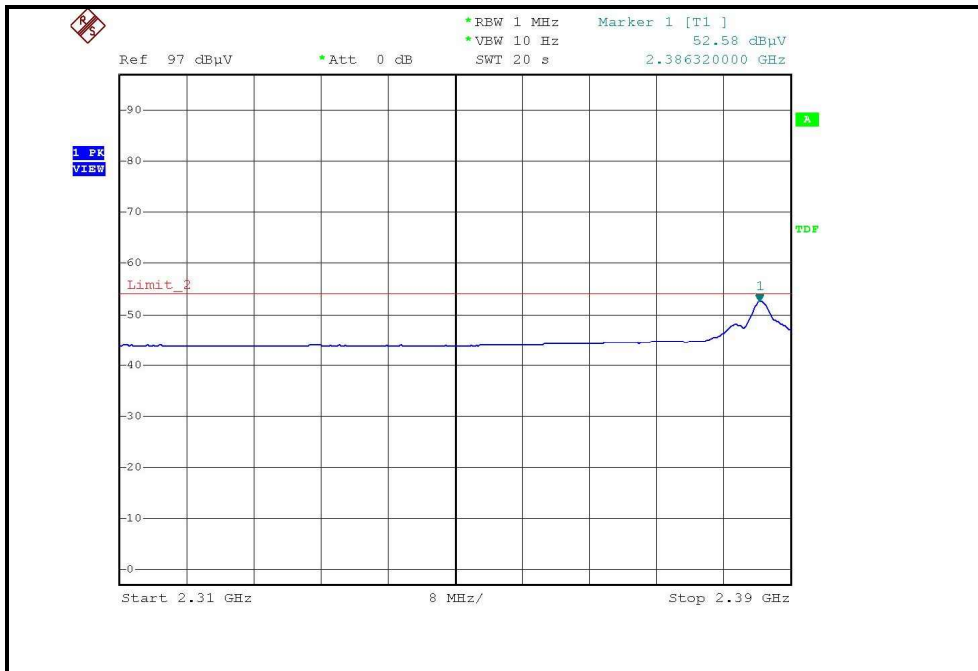
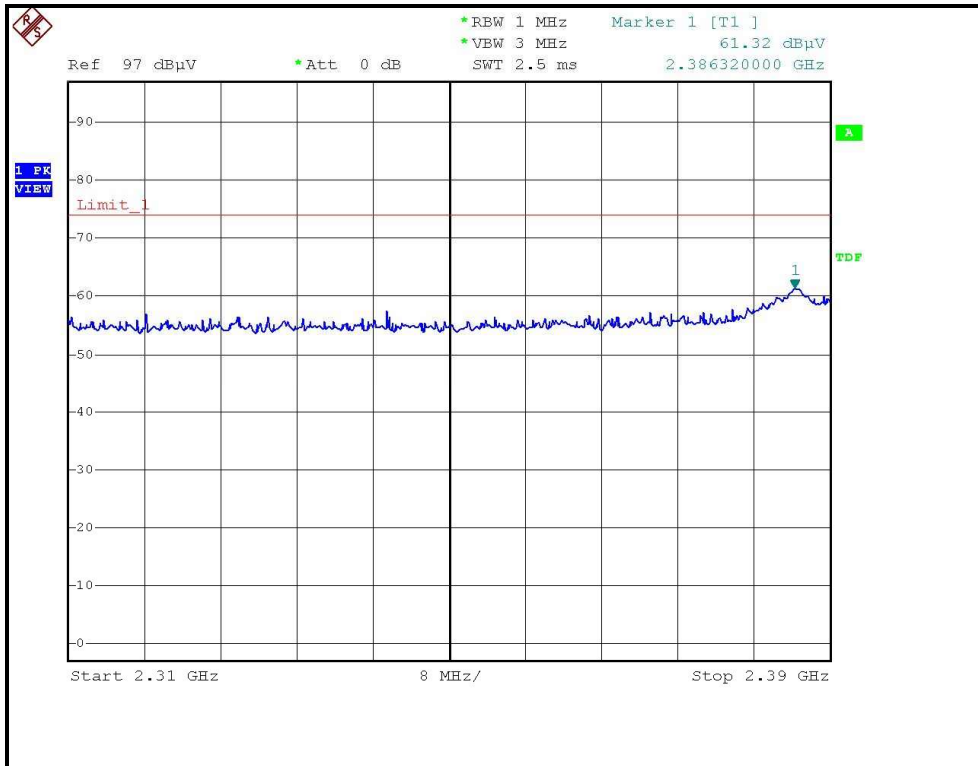

RESTRICTED BANDEDGE (802.11b MODE,CH11, HORIZONTAL)

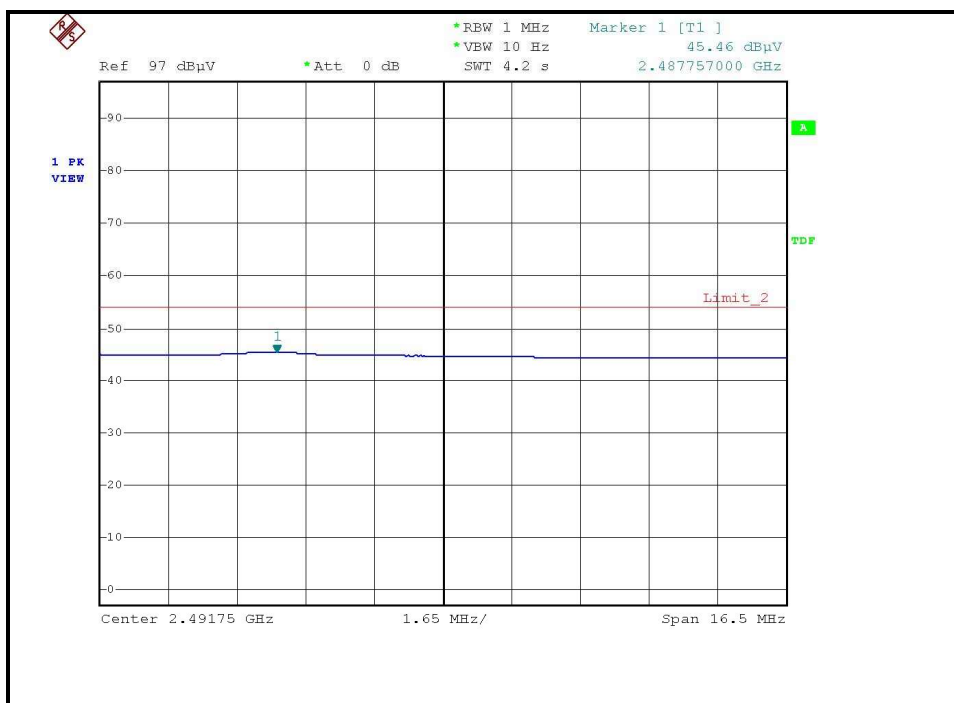
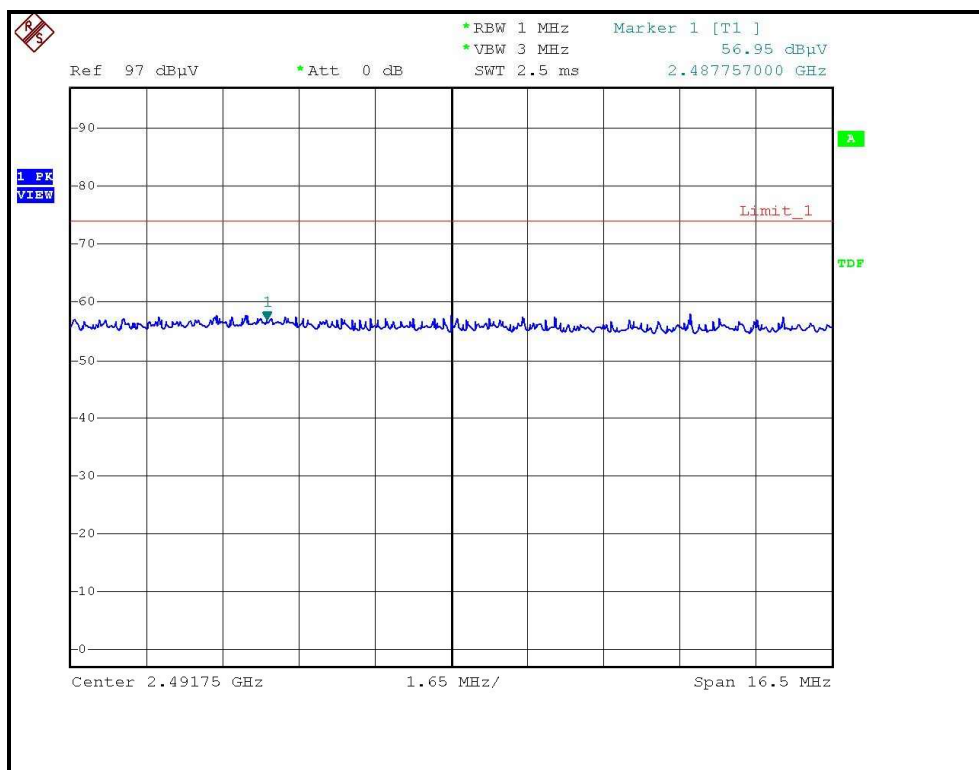

RESTRICTED BANDEDGE (802.11b MODE, CH11, VERTICAL)

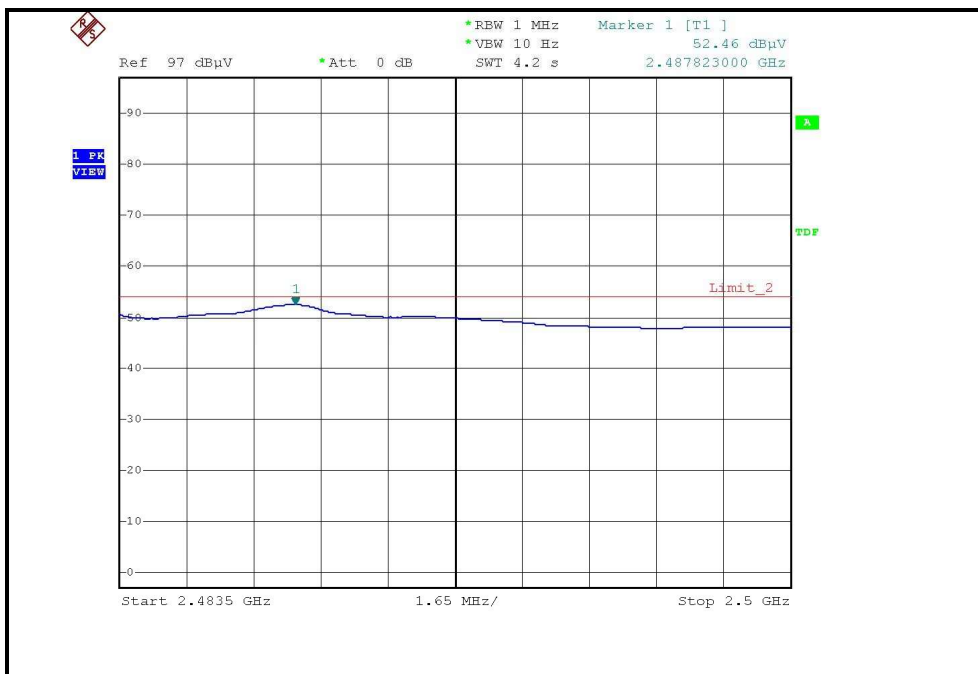
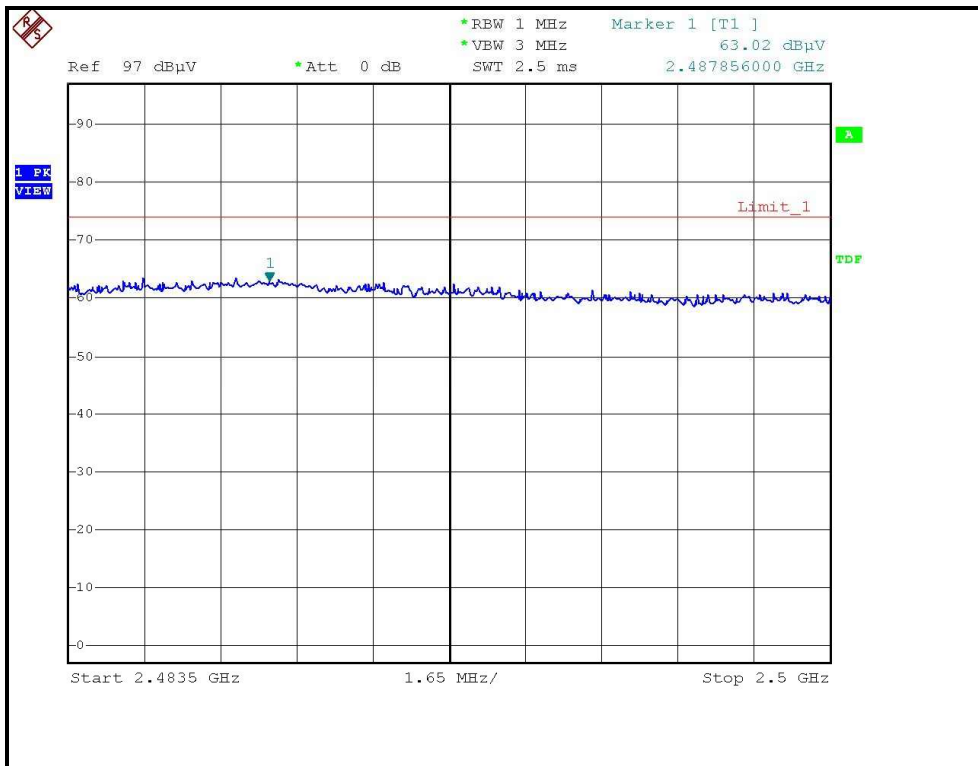

802.11g OFDM MODULATION:

EUT TEST CONDITION		MEASUREMENT DETAIL	
CHANNEL	Channel 1	FREQUENCY RANGE	1 ~ 25GHz
MODULATION TYPE	BPSK	INPUT POWER (SYSTEM)	120Vac, 60 Hz
TRANSFER RATE	6Mbps	DETECTOR FUNCTION	Peak(PK) Average (AV)
ENVIRONMENTAL CONDITIONS	20deg. C, 70%RH, 955hPa	TESTED BY	Rex Huang

ANTENNA POLARITY & TEST DISTANCE: HORIZONTAL AT 3 M

No.	Freq. (MHz)	Emission Level (dBuV/m)	Limit (dBuV/m)	Margin (dB)	Antenna Height (m)	Table Angle (Degree)	Raw Value (dBuV)	Correction Factor (dB/m)
1	2390.00	53.87 PK	74.00	-20.13	1.46 H	26	23.47	30.40
2	2390.00	43.64 AV	54.00	-10.36	1.46 H	26	13.24	30.40
3	*2412.00	94.96 PK			1.38 H	15	64.47	30.49
4	*2412.00	84.83 AV			1.38 H	15	54.34	30.49
5	4824.00	45.90 PK	74.00	-28.10	1.29 H	207	10.21	35.69
6	4824.00	32.20 AV	54.00	-21.80	1.29 H	207	-3.49	35.69
7	7236.00	52.70 PK	74.00	-21.30	1.09 H	316	10.46	42.24
8	7236.00	39.30 AV	54.00	-14.70	1.09 H	316	-2.94	42.24

ANTENNA POLARITY & TEST DISTANCE: VERTICAL AT 3 M

No.	Freq. (MHz)	Emission Level (dBuV/m)	Limit (dBuV/m)	Margin (dB)	Antenna Height (m)	Table Angle (Degree)	Raw Value (dBuV)	Correction Factor (dB/m)
1	2390.00	63.09 PK	74.00	-10.91	1.46 V	269	32.70	30.40
2	2390.00	47.90 AV	54.00	-6.10	1.46 V	269	17.50	30.40
3	*2412.00	108.95 PK			1.47 V	270	78.46	30.49
4	*2412.00	98.91 AV			1.47 V	270	68.42	30.49
5	4824.00	46.70 PK	74.00	-27.30	1.26 V	61	11.01	35.69
6	4824.00	32.90 AV	54.00	-21.10	1.26 V	61	-2.79	35.69
7	7236.00	52.60 PK	74.00	-21.40	1.34 V	283	10.36	42.24
8	7236.00	39.10 AV	54.00	-14.90	1.34 V	283	-3.14	42.24

- REMARKS:**
1. Emission level (dBuV/m) = Raw Value (dBuV) + Correction Factor (dB/m).
 2. Correction Factor (dB/m) = Antenna Factor (dB/m) + Cable Factor (dB).
 3. The other emission levels were very low against the limit.
 4. Margin value = Emission level – Limit value.
 5. The limit value is defined as per 15.247.
 6. “ * “: Fundamental frequency.

EUT TEST CONDITION		MEASUREMENT DETAIL	
CHANNEL	Channel 6	FREQUENCY RANGE	1 ~ 25GHz
MODULATION TYPE	BPSK	INPUT POWER (SYSTEM)	120Vac, 60 Hz
TRANSFER RATE	6Mbps	DETECTOR FUNCTION	Peak(PK) Average (AV)
ENVIRONMENTAL CONDITIONS	20deg. C, 70%RH, 955hPa	TESTED BY	Rex Huang

ANTENNA POLARITY & TEST DISTANCE: HORIZONTAL AT 3 M

No.	Freq. (MHz)	Emission Level (dBuV/m)	Limit (dBuV/m)	Margin (dB)	Antenna Height (m)	Table Angle (Degree)	Raw Value (dBuV)	Correction Factor (dB/m)
1	*2437.00	109.21 PK			1.27 H	196	78.60	30.61
2	*2437.00	86.70 AV			1.27 H	196	56.09	30.61
3	4874.00	46.60 PK	74.00	-27.40	1.34 H	216	10.80	35.80
4	4874.00	32.80 AV	54.00	-21.20	1.34 H	216	-3.00	35.80
5	7311.00	53.30 PK	74.00	-20.70	1.14 H	332	10.78	42.52
6	7311.00	39.40 AV	54.00	-14.60	1.14 H	332	-3.12	42.52

ANTENNA POLARITY & TEST DISTANCE: VERTICAL AT 3 M

No.	Freq. (MHz)	Emission Level (dBuV/m)	Limit (dBuV/m)	Margin (dB)	Antenna Height (m)	Table Angle (Degree)	Raw Value (dBuV)	Correction Factor (dB/m)
1	*2437.00	108.40 PK			1.49 V	221	77.79	30.61
2	*2437.00	98.40 AV			1.49 V	221	67.79	30.61
3	4874.00	47.30 PK	74.00	-26.70	1.25 V	76	11.50	35.80
4	4874.00	33.70 AV	54.00	-20.30	1.25 V	76	-2.10	35.80
5	7311.00	53.40 PK	74.00	-20.60	1.37 V	265	10.88	42.52
6	7311.00	39.60 AV	54.00	-14.40	1.37 V	265	-2.92	42.52

- REMARKS:**
1. Emission level (dBuV/m) = Raw Value (dBuV) + Correction Factor (dB/m).
 2. Correction Factor (dB/m) = Antenna Factor (dB/m) + Cable Factor (dB).
 3. The other emission levels were very low against the limit.
 4. Margin value = Emission level – Limit value.
 5. The limit value is defined as per 15.247.
 6. “ * “: Fundamental frequency.

EUT TEST CONDITION		MEASUREMENT DETAIL	
CHANNEL	Channel 11	FREQUENCY RANGE	1 ~ 25GHz
MODULATION TYPE	BPSK	INPUT POWER (SYSTEM)	120Vac, 60 Hz
TRANSFER RATE	6Mbps	DETECTOR FUNCTION	Peak(PK) Average (AV)
ENVIRONMENTAL CONDITIONS	20deg. C, 70%RH, 955hPa	TESTED BY	Rex Huang

ANTENNA POLARITY & TEST DISTANCE: HORIZONTAL AT 3 M

No.	Freq. (MHz)	Emission Level (dBuV/m)	Limit (dBuV/m)	Margin (dB)	Antenna Height (m)	Table Angle (Degree)	Raw Value (dBuV)	Correction Factor (dB/m)
1	*2462.00	97.49 PK			1.26 H	330	66.77	30.72
2	*2462.00	87.23 AV			1.26 H	330	56.51	30.72
3	2483.50	54.63 PK	74.00	-19.37	1.37 H	187	23.81	30.82
4	2483.50	44.47 AV	54.00	-9.53	1.37 H	187	13.65	30.82
5	4924.00	47.10 PK	74.00	-26.90	1.31 H	248	11.20	35.90
6	4924.00	33.10 AV	54.00	-20.90	1.31 H	248	-2.80	35.90
7	7386.00	53.60 PK	74.00	-20.40	1.03 H	268	10.80	42.80
8	7386.00	39.80 AV	54.00	-14.20	1.03 H	268	-3.00	42.80

ANTENNA POLARITY & TEST DISTANCE: VERTICAL AT 3 M

No.	Freq. (MHz)	Emission Level (dBuV/m)	Limit (dBuV/m)	Margin (dB)	Antenna Height (m)	Table Angle (Degree)	Raw Value (dBuV)	Correction Factor (dB/m)
1	*2462.00	108.27 PK			1.67 V	120	77.55	30.72
2	*2462.00	98.09 AV			1.67 V	120	67.37	30.72
3	2483.50	68.61 PK	74.00	-5.39	1.64 V	130	37.79	30.82
4	2483.50	50.26 AV	54.00	-3.74	1.64 V	130	19.44	30.82
5	4924.00	46.90 PK	74.00	-27.10	1.21 V	106	11.00	35.90
6	4924.00	33.40 AV	54.00	-20.60	1.21 V	106	-2.50	35.90
7	7386.00	53.80 PK	74.00	-20.20	1.43 V	295	11.00	42.80
8	7386.00	39.90 AV	54.00	-14.10	1.43 V	295	-2.90	42.80

- REMARKS:**
1. Emission level (dBuV/m) = Raw Value (dBuV) + Correction Factor (dB/m).
 2. Correction Factor (dB/m) = Antenna Factor (dB/m) + Cable Factor (dB).
 3. The other emission levels were very low against the limit.
 4. Margin value = Emission level – Limit value.
 5. The limit value is defined as per 15.247.
 6. “ * “: Fundamental frequency.

RESTRICTED BANDEDGE (802.11g MODE, CH1, HORIZONTAL)

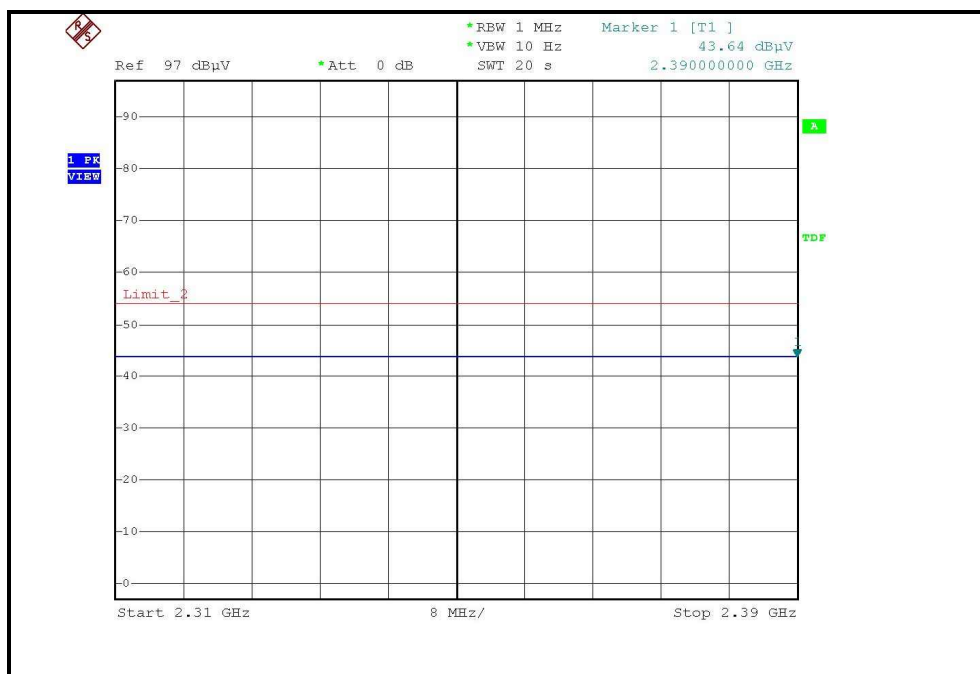
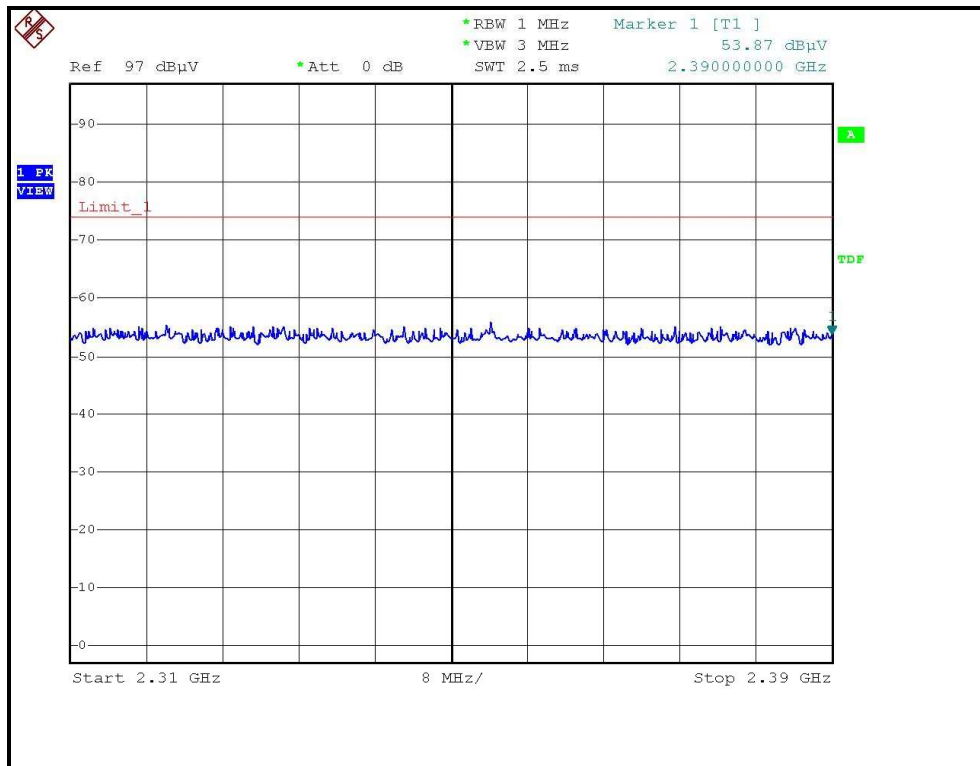

RESTRICTED BANDEDGE (802.11g MODE, CH1, VERTICAL)

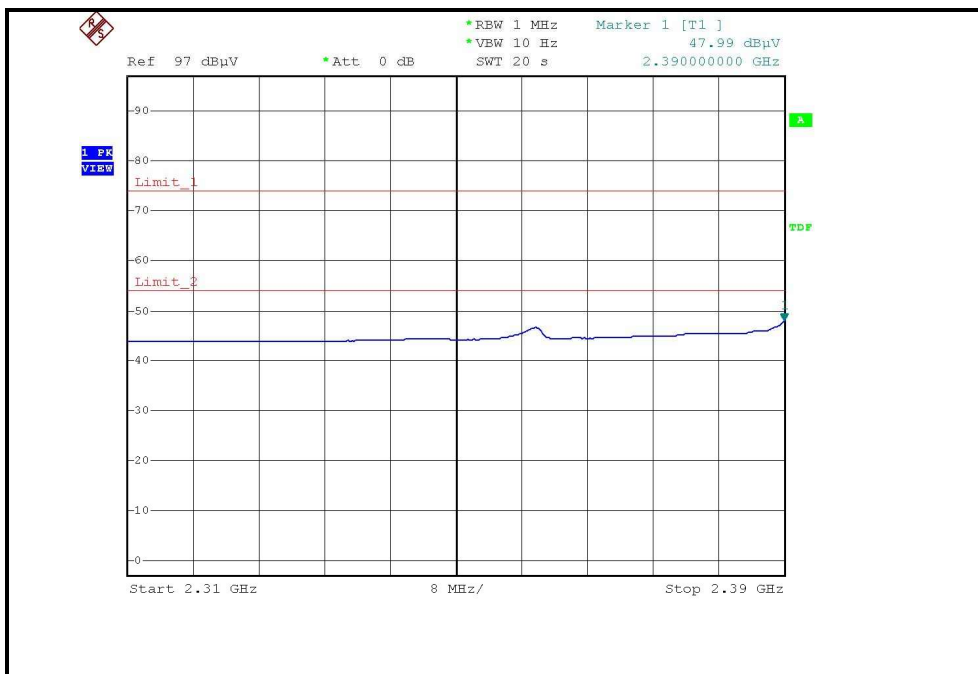
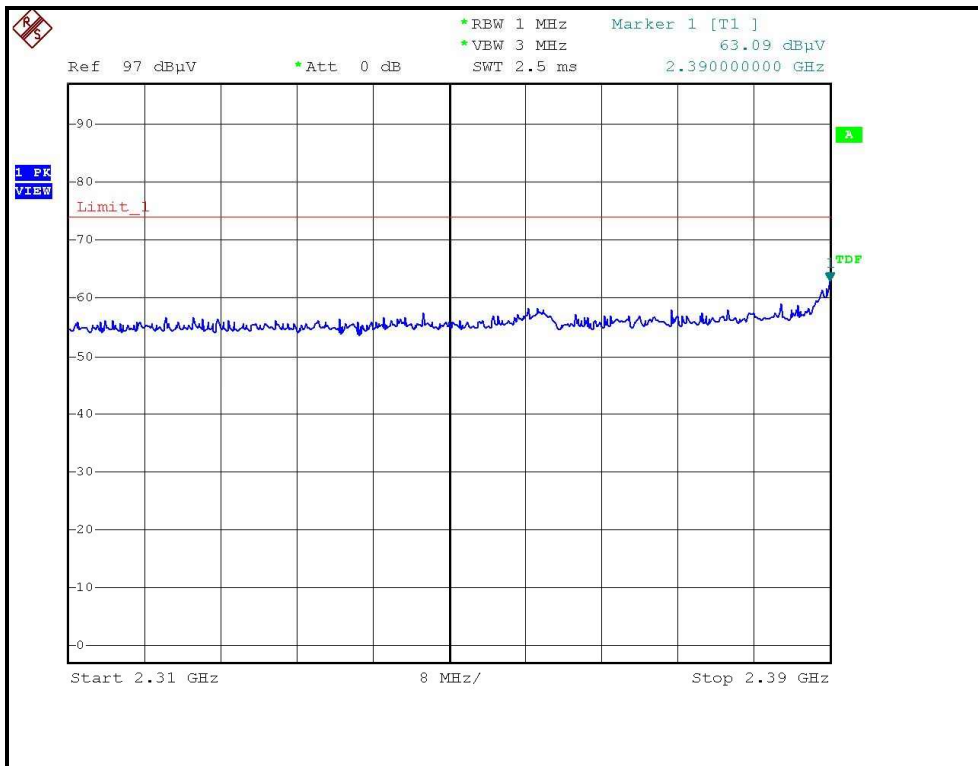

RESTRICTED BANDEDGE (802.11g MODE, CH11, HORIZONTAL)

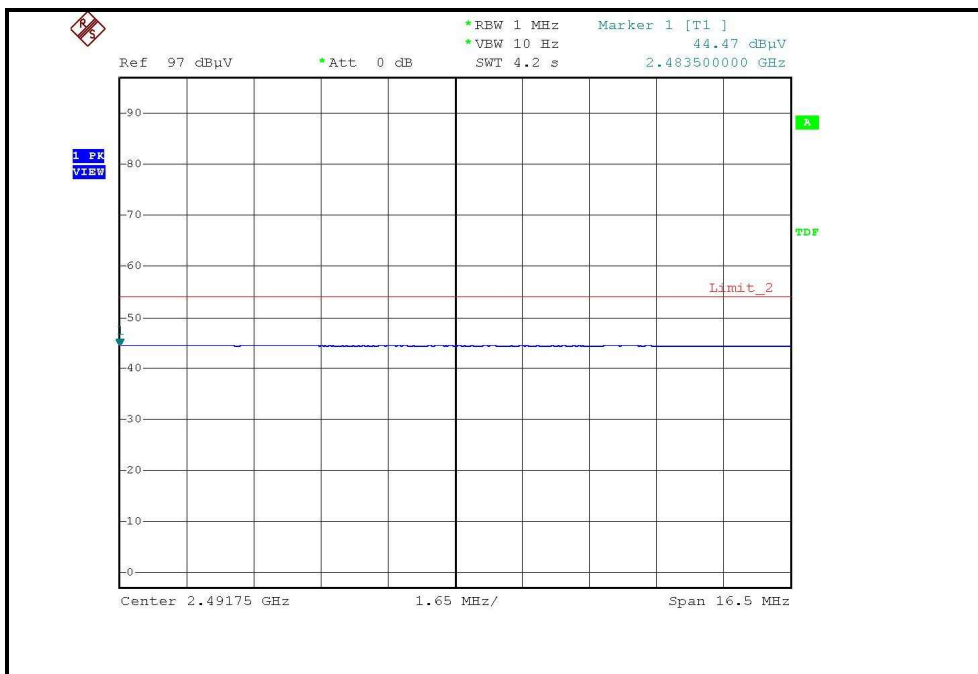
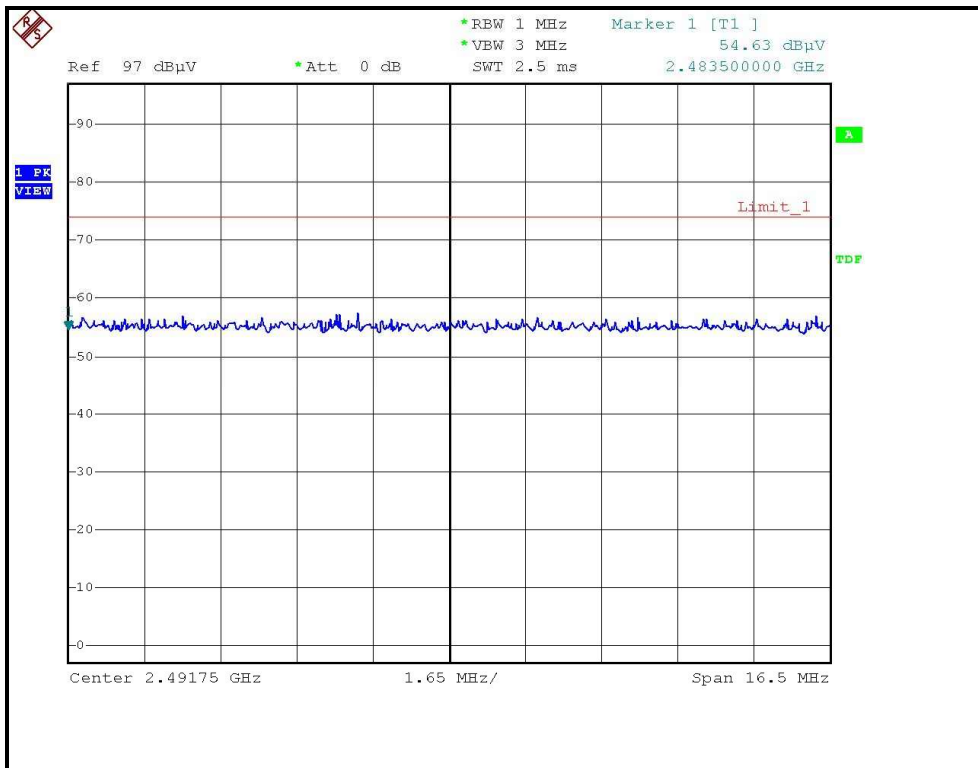

RESTRICTED BANDEDGE (802.11g MODE, CH11, VERTICAL)

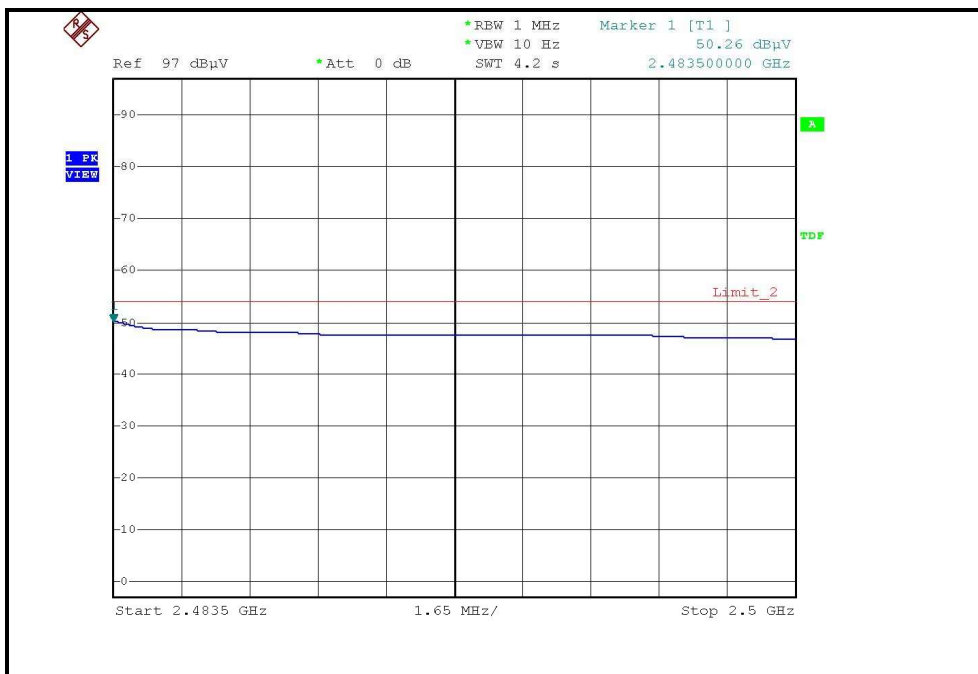
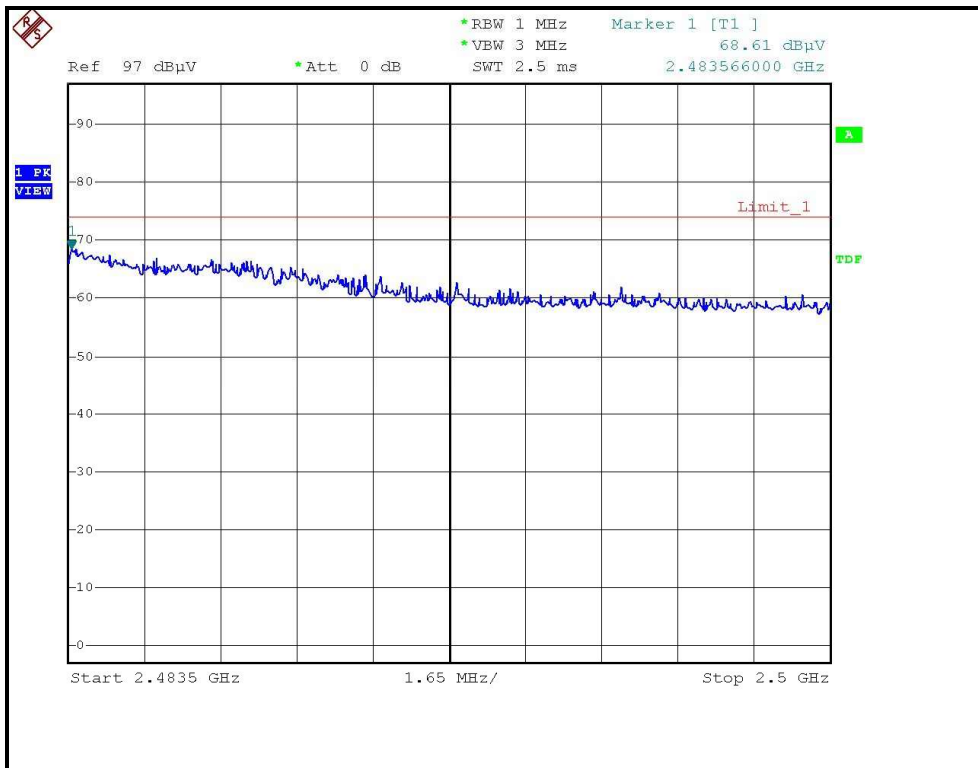

DRAFT 802.11n (20MHz) OFDM MODULATION:

EUT TEST CONDITION		MEASUREMENT DETAIL	
CHANNEL	Channel 1	FREQUENCY RANGE	1 ~ 25GHz
MODULATION TYPE	BPSK	INPUT POWER (SYSTEM)	120Vac, 60 Hz
TRANSFER RATE	6.5Mbps	DETECTOR FUNCTION	Peak(PK) Average (AV)
ENVIRONMENTAL CONDITIONS	20deg. C, 70%RH, 955hPa	TESTED BY	Rex Huang

ANTENNA POLARITY & TEST DISTANCE: HORIZONTAL AT 3 M

No.	Freq. (MHz)	Emission Level (dBuV/m)	Limit (dBuV/m)	Margin (dB)	Antenna Height (m)	Table Angle (Degree)	Raw Value (dBuV)	Correction Factor (dB/m)
1	2390.00	54.97 PK	74.00	-19.03	1.40 H	21	24.57	30.40
2	2390.00	44.17 AV	54.00	-9.83	1.40 H	21	13.77	30.40
3	*2412.00	102.53 PK			1.38 H	89	72.04	30.49
4	*2412.00	92.10 AV			1.38 H	89	61.61	30.49
5	4824.00	46.40 PK	74.00	-27.60	1.27 H	313	10.71	35.69
6	4824.00	33.40 AV	54.00	-20.60	1.27 H	313	-2.29	35.69
7	7236.00	52.90 PK	74.00	-21.10	1.19 H	126	10.66	42.24
8	7236.00	39.40 AV	54.00	-14.60	1.19 H	126	-2.84	42.24

ANTENNA POLARITY & TEST DISTANCE: VERTICAL AT 3 M

No.	Freq. (MHz)	Emission Level (dBuV/m)	Limit (dBuV/m)	Margin (dB)	Antenna Height (m)	Table Angle (Degree)	Raw Value (dBuV)	Correction Factor (dB/m)
1	2360.00	59.77 PK	74.00	-14.23	1.72 V	274	29.51	30.26
2	2360.00	49.23 AV	54.00	-4.77	1.72 V	274	18.97	30.26
3	*2412.00	111.68 PK			1.70 V	294	81.19	30.49
4	*2412.00	101.15 AV			1.70 V	294	70.66	30.49
5	4824.00	47.50 PK	74.00	-26.50	1.47 V	18	11.81	35.69
6	4824.00	34.60 AV	54.00	-19.40	1.47 V	18	-1.09	35.69
7	7236.00	52.80 PK	74.00	-21.20	1.31 V	273	10.56	42.24
8	7236.00	39.20 AV	54.00	-14.80	1.31 V	273	-3.04	42.24

- REMARKS:**
1. Emission level (dBuV/m) = Raw Value (dBuV) + Correction Factor (dB/m).
 2. Correction Factor (dB/m) = Antenna Factor (dB/m) + Cable Factor (dB).
 3. The other emission levels were very low against the limit.
 4. Margin value = Emission level – Limit value.
 5. The limit value is defined as per 15.247.
 6. “ * “: Fundamental frequency.

EUT TEST CONDITION		MEASUREMENT DETAIL	
CHANNEL	Channel 6	FREQUENCY RANGE	1 ~ 25GHz
MODULATION TYPE	BPSK	INPUT POWER (SYSTEM)	120Vac, 60 Hz
TRANSFER RATE	6.5Mbps	DETECTOR FUNCTION	Peak(PK) Average (AV)
ENVIRONMENTAL CONDITIONS	20deg. C, 70%RH, 955hPa	TESTED BY	Rex Huang

ANTENNA POLARITY & TEST DISTANCE: HORIZONTAL AT 3 M

No.	Freq. (MHz)	Emission Level (dBuV/m)	Limit (dBuV/m)	Margin (dB)	Antenna Height (m)	Table Angle (Degree)	Raw Value (dBuV)	Correction Factor (dB/m)
1	*2437.00	102.60 PK			1.42 H	97	71.99	30.61
2	*2437.00	92.30 AV			1.42 H	97	61.69	30.61
3	4874.00	47.30 PK	74.00	-26.70	1.25 H	334	11.50	35.80
4	4874.00	34.20 AV	54.00	-19.80	1.25 H	334	-1.60	35.80
5	7311.00	53.00 PK	74.00	-21.00	1.17 H	179	10.48	42.52
6	7311.00	39.60 AV	54.00	-14.40	1.17 H	179	-2.92	42.52

ANTENNA POLARITY & TEST DISTANCE: VERTICAL AT 3 M

No.	Freq. (MHz)	Emission Level (dBuV/m)	Limit (dBuV/m)	Margin (dB)	Antenna Height (m)	Table Angle (Degree)	Raw Value (dBuV)	Correction Factor (dB/m)
1	*2437.00	112.90 PK			1.64 V	302	82.29	30.61
2	*2437.00	102.70 AV			1.64 V	302	72.09	30.61
3	4874.00	47.60 PK	74.00	-26.40	1.35 V	14	11.80	35.80
4	4874.00	34.90 AV	54.00	-19.10	1.35 V	14	-0.90	35.80
5	7311.00	52.70 PK	74.00	-21.30	1.42 V	269	10.18	42.52
6	7311.00	39.40 AV	54.00	-14.60	1.42 V	269	-3.12	42.52

- REMARKS:**
1. Emission level (dBuV/m) = Raw Value (dBuV) + Correction Factor (dB/m).
 2. Correction Factor (dB/m) = Antenna Factor (dB/m) + Cable Factor (dB).
 3. The other emission levels were very low against the limit.
 4. Margin value = Emission level – Limit value.
 5. The limit value is defined as per 15.247.
 6. “ * “: Fundamental frequency.

EUT TEST CONDITION		MEASUREMENT DETAIL	
CHANNEL	Channel 11	FREQUENCY RANGE	1 ~ 25GHz
MODULATION TYPE	BPSK	INPUT POWER (SYSTEM)	120Vac, 60 Hz
TRANSFER RATE	6.5Mbps	DETECTOR FUNCTION	Peak(PK) Average (AV)
ENVIRONMENTAL CONDITIONS	20deg. C, 70%RH, 955hPa	TESTED BY	Rex Huang

ANTENNA POLARITY & TEST DISTANCE: HORIZONTAL AT 3 M								
No.	Freq. (MHz)	Emission Level (dBuV/m)	Limit (dBuV/m)	Margin (dB)	Antenna Height (m)	Table Angle (Degree)	Raw Value (dBuV)	Correction Factor (dB/m)
1	*2462.00	99.12 PK			1.23 H	260	68.40	30.72
2	*2462.00	89.21 AV			1.23 H	260	58.49	30.72
3	2483.50	55.10 PK	74.00	-18.90	1.07 H	242	24.28	30.82
4	2483.50	44.90 AV	54.00	-9.10	1.07 H	242	14.08	30.82
5	4924.00	47.10 PK	74.00	-26.90	1.31 H	5	11.20	35.90
6	4924.00	33.10 AV	54.00	-20.90	1.31 H	5	-2.80	35.90
7	7386.00	53.20 PK	74.00	-20.80	1.08 H	235	10.40	42.80
8	7386.00	39.90 AV	54.00	-14.10	1.08 H	235	-2.90	42.80

ANTENNA POLARITY & TEST DISTANCE: VERTICAL AT 3 M								
No.	Freq. (MHz)	Emission Level (dBuV/m)	Limit (dBuV/m)	Margin (dB)	Antenna Height (m)	Table Angle (Degree)	Raw Value (dBuV)	Correction Factor (dB/m)
1	*2462.00	115.27 PK			1.69 V	301	84.55	30.72
2	*2462.00	104.59 AV			1.69 V	301	73.87	30.72
3	2483.50	67.02 PK	74.00	-6.98	1.68 V	275	36.20	30.82
4	2483.50	51.43 AV	54.00	-2.57	1.68 V	275	20.61	30.82
5	4924.00	47.50 PK	74.00	-26.50	1.37 V	36	11.60	35.90
6	4924.00	34.30 AV	54.00	-19.70	1.37 V	36	-1.60	35.90
7	7386.00	53.40 PK	74.00	-20.60	1.32 V	315	10.60	42.80
8	7386.00	39.70 AV	54.00	-14.30	1.32 V	315	-3.10	42.80

- REMARKS:**
1. Emission level (dBuV/m) = Raw Value (dBuV) + Correction Factor (dB/m).
 2. Correction Factor (dB/m) = Antenna Factor (dB/m) + Cable Factor (dB).
 3. The other emission levels were very low against the limit.
 4. Margin value = Emission level – Limit value.
 5. The limit value is defined as per 15.247.
 6. " * ": Fundamental frequency.

RESTRICTED BANDEDGE (DRAFT 802.11n (20MHz) MODE, CH1, VERTICAL)

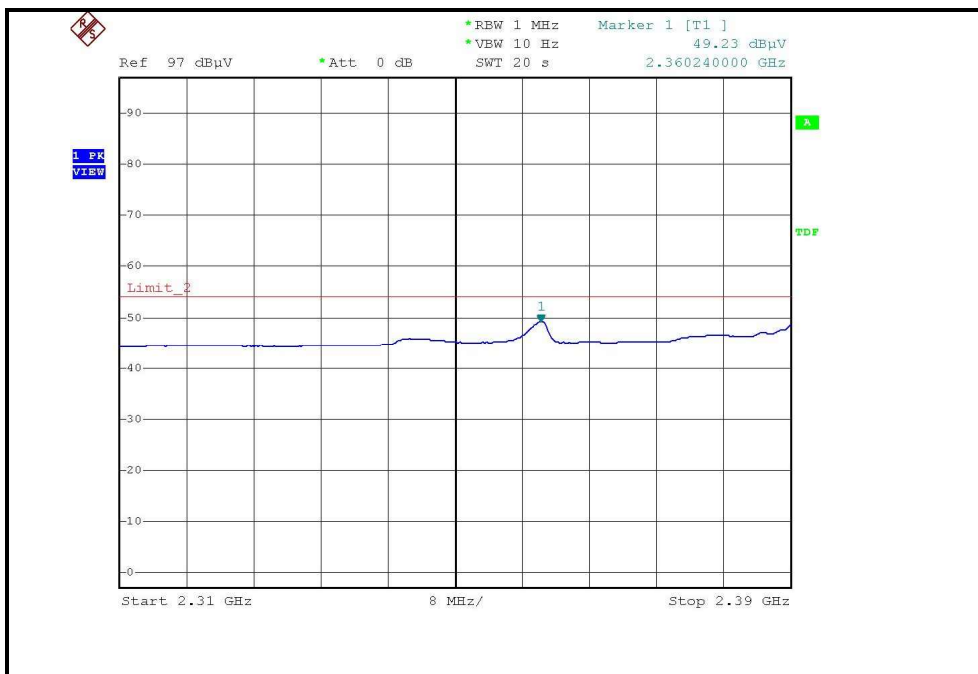
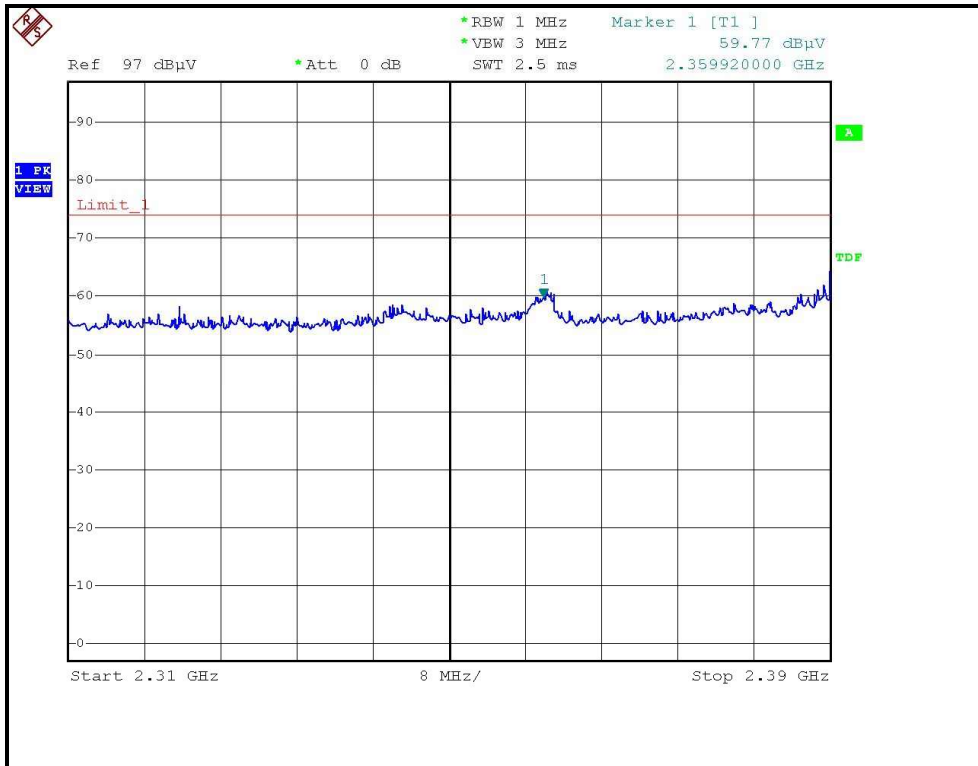

RESTRICTED BANDEDGE (DRAFT 802.11n (20MHz) MODE,CH11, VERTICAL)

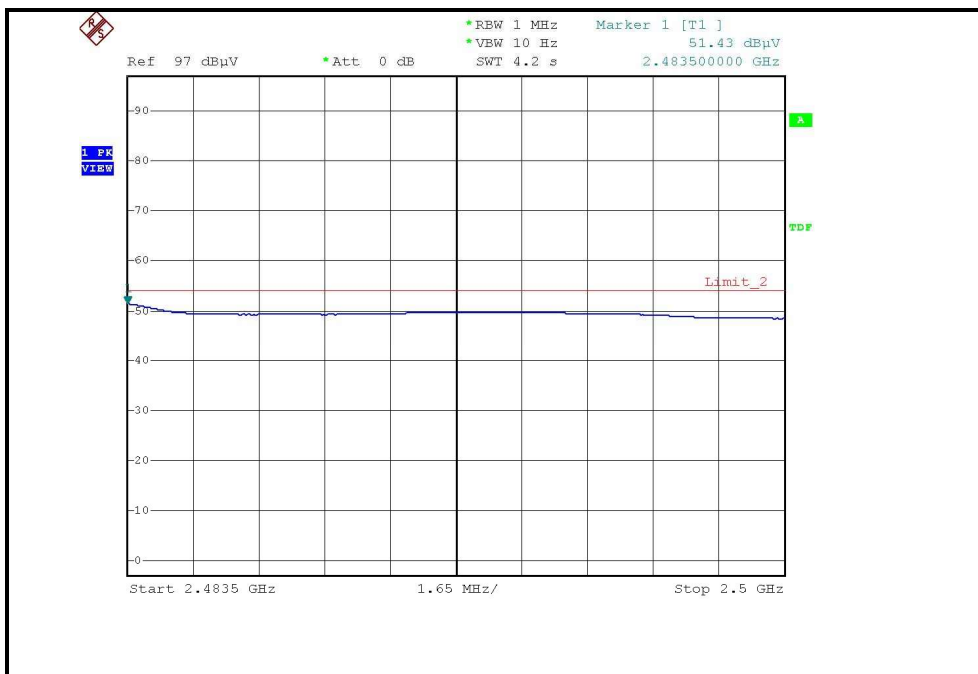
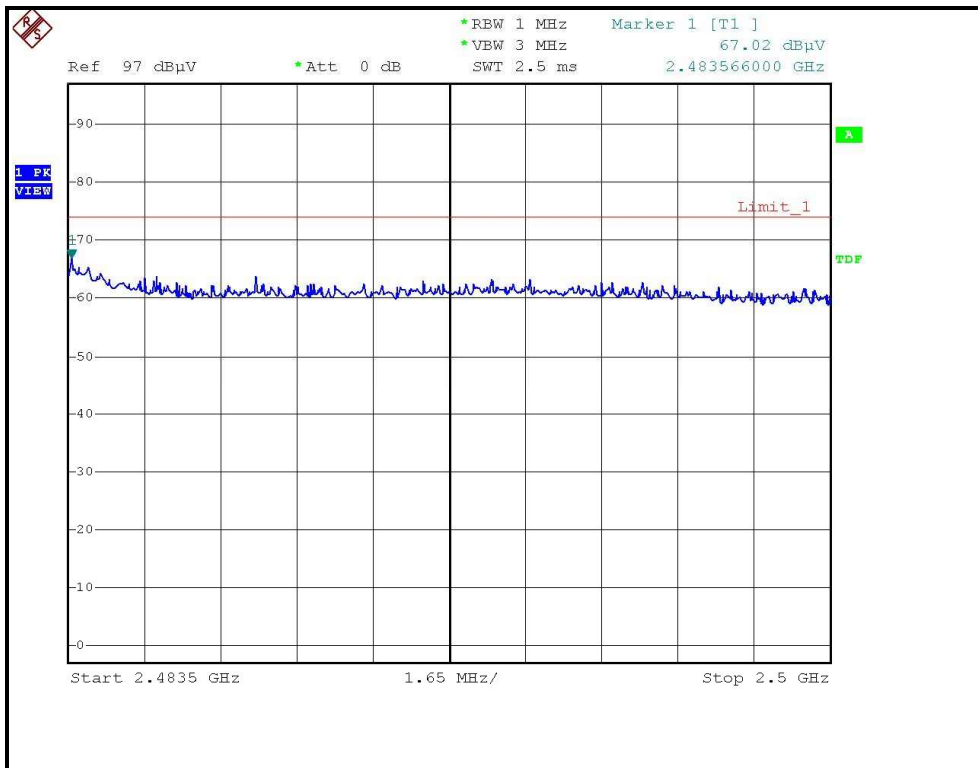

DRAFT 802.11n (40MHz) OFDM MODULATION:

EUT TEST CONDITION		MEASUREMENT DETAIL	
CHANNEL	Channel 1	FREQUENCY RANGE	1 ~ 25GHz
MODULATION TYPE	BPSK	INPUT POWER (SYSTEM)	120Vac, 60 Hz
TRANSFER RATE	13.5Mbps	DETECTOR FUNCTION	Peak(PK) Average (AV)
ENVIRONMENTAL CONDITIONS	20deg. C, 70%RH, 955hPa	TESTED BY	Rex Huang

ANTENNA POLARITY & TEST DISTANCE: HORIZONTAL AT 3 M

No.	Freq. (MHz)	Emission Level (dBuV/m)	Limit (dBuV/m)	Margin (dB)	Antenna Height (m)	Table Angle (Degree)	Raw Value (dBuV)	Correction Factor (dB/m)
1	2390.00	55.94 PK	74.00	-18.06	2.14 H	293	25.54	30.40
2	2390.00	45.47 AV	54.00	-8.53	2.14 H	293	15.07	30.40
3	*2422.00	96.55 PK			1.96 H	255	66.01	30.54
4	*2422.00	86.73 AV			1.96 H	255	56.19	30.54
5	4844.00	46.90 PK	74.00	-27.10	1.29 H	14	11.16	35.74
6	4844.00	32.80 AV	54.00	-21.20	1.29 H	14	-2.94	35.74
7	7266.00	52.80 PK	74.00	-21.20	1.37 H	346	10.45	42.35
8	7266.00	39.60 AV	54.00	-14.40	1.37 H	346	-2.75	42.35

ANTENNA POLARITY & TEST DISTANCE: VERTICAL AT 3 M

No.	Freq. (MHz)	Emission Level (dBuV/m)	Limit (dBuV/m)	Margin (dB)	Antenna Height (m)	Table Angle (Degree)	Raw Value (dBuV)	Correction Factor (dB/m)
1	2390.00	61.58 PK	74.00	-12.42	1.44 V	270	21.18	30.40
2	2390.00	49.77 AV	54.00	-4.23	1.44 V	270	19.37	30.40
3	*2422.00	110.57 PK			1.44 V	277	80.03	30.54
4	*2422.00	100.26 AV			1.44 V	277	69.72	30.54
5	4844.00	47.30 PK	74.00	-26.70	1.27 V	18	11.56	35.74
6	4844.00	33.40 AV	54.00	-20.60	1.27 V	18	-2.34	35.74
7	7266.00	53.10 PK	74.00	-20.90	1.34 V	265	10.75	42.35
8	7266.00	39.50 AV	54.00	-14.50	1.34 V	265	-2.85	42.35

- REMARKS:**
1. Emission level (dBuV/m) = Raw Value (dBuV) + Correction Factor (dB/m).
 2. Correction Factor (dB/m) = Antenna Factor (dB/m) + Cable Factor (dB).
 3. The other emission levels were very low against the limit.
 4. Margin value = Emission level – Limit value.
 5. The limit value is defined as per 15.247.
 6. " * ": Fundamental frequency.

EUT TEST CONDITION		MEASUREMENT DETAIL	
CHANNEL	Channel 4	FREQUENCY RANGE	1 ~ 25GHz
MODULATION TYPE	BPSK	INPUT POWER (SYSTEM)	120Vac, 60 Hz
TRANSFER RATE	13.5Mbps	DETECTOR FUNCTION	Peak(PK) Average (AV)
ENVIRONMENTAL CONDITIONS	20deg. C, 70%RH, 955hPa	TESTED BY	Rex Huang

ANTENNA POLARITY & TEST DISTANCE: HORIZONTAL AT 3 M

No.	Freq. (MHz)	Emission Level (dBuV/m)	Limit (dBuV/m)	Margin (dB)	Antenna Height (m)	Table Angle (Degree)	Raw Value (dBuV)	Correction Factor (dB/m)
1	*2437.00	96.70 PK			1.73 H	269	66.09	30.61
2	*2437.00	85.28 AV			1.73 H	269	54.67	30.61
3	4874.00	47.40 PK	74.00	-26.60	1.30 H	16	11.60	35.80
4	4874.00	33.20 AV	54.00	-20.80	1.30 H	16	-2.60	35.80
5	7311.00	52.70 PK	74.00	-21.30	1.25 H	287	10.18	42.52
6	7311.00	39.50 AV	54.00	-14.50	1.25 H	287	-3.02	42.52

ANTENNA POLARITY & TEST DISTANCE: VERTICAL AT 3 M

No.	Freq. (MHz)	Emission Level (dBuV/m)	Limit (dBuV/m)	Margin (dB)	Antenna Height (m)	Table Angle (Degree)	Raw Value (dBuV)	Correction Factor (dB/m)
1	*2437.00	108.60 PK			1.43 V	260	77.99	30.61
2	*2437.00	99.72 AV			1.43 V	260	69.11	30.61
3	4874.00	48.10 PK	74.00	-25.90	1.32 V	21	12.30	35.80
4	4874.00	34.30 AV	54.00	-19.70	1.32 V	21	-1.50	35.80
5	7311.00	52.60 PK	74.00	-21.40	1.41 V	283	10.08	42.52
6	7311.00	39.30 AV	54.00	-14.70	1.41 V	283	-3.22	42.52

- REMARKS:**
1. Emission level (dBuV/m) = Raw Value (dBuV) + Correction Factor (dB/m).
 2. Correction Factor (dB/m) = Antenna Factor (dB/m) + Cable Factor (dB).
 3. The other emission levels were very low against the limit.
 4. Margin value = Emission level – Limit value.
 5. The limit value is defined as per 15.247.
 6. “ * “: Fundamental frequency.

EUT TEST CONDITION		MEASUREMENT DETAIL	
CHANNEL	Channel 7	FREQUENCY RANGE	1 ~ 25GHz
MODULATION TYPE	BPSK	INPUT POWER (SYSTEM)	120Vac, 60 Hz
TRANSFER RATE	13.5Mbps	DETECTOR FUNCTION	Peak(PK) Average (AV)
ENVIRONMENTAL CONDITIONS	26deg. C, 68%RH, 955hPa	TESTED BY	Sky Liao

ANTENNA POLARITY & TEST DISTANCE: HORIZONTAL AT 3 M								
No.	Freq. (MHz)	Emission Level (dBuV/m)	Limit (dBuV/m)	Margin (dB)	Antenna Height (m)	Table Angle (Degree)	Raw Value (dBuV)	Correction Factor (dB/m)
1	*2452.00	94.71 PK			1.06 H	277	64.04	30.67
2	*2452.00	84.27 AV			1.06 H	277	53.60	30.67
3	2484.00	57.16 PK	74.00	-16.84	1.08 H	243	26.34	30.82
4	2484.00	46.97 AV	54.00	-7.03	1.08 H	243	16.15	30.82
5	4904.00	47.30 PK	74.00	-26.70	1.21 H	43	11.44	35.86
6	4904.00	33.60 AV	54.00	-20.40	1.21 H	43	-2.26	35.86
7	7356.00	53.50 PK	74.00	-20.50	1.43 H	316	10.82	42.68
8	7356.00	39.90 AV	54.00	-14.10	1.43 H	316	-2.78	42.68

ANTENNA POLARITY & TEST DISTANCE: VERTICAL AT 3 M								
No.	Freq. (MHz)	Emission Level (dBuV/m)	Limit (dBuV/m)	Margin (dB)	Antenna Height (m)	Table Angle (Degree)	Raw Value (dBuV)	Correction Factor (dB/m)
1	*2452.00	108.56 PK			1.45 V	263	77.89	30.67
2	*2452.00	98.04 AV			1.45 V	263	67.37	30.67
3	2484.00	67.25 PK	74.00	-6.75	1.39 V	138	36.43	30.82
4	2484.00	53.34 AV	54.00	-0.66	1.39 V	138	22.52	30.82
5	4904.00	47.80 PK	74.00	-26.20	1.34 V	31	11.94	35.86
6	4904.00	34.20 AV	54.00	-19.80	1.34 V	31	-1.66	35.86
7	7356.00	53.20 PK	74.00	-20.80	1.38 V	243	10.52	42.68
8	7356.00	39.80 AV	54.00	-14.20	1.38 V	243	-2.88	42.68

- REMARKS:**
1. Emission level (dBuV/m) = Raw Value (dBuV) + Correction Factor (dB/m).
 2. Correction Factor (dB/m) = Antenna Factor (dB/m) + Cable Factor (dB).
 3. The other emission levels were very low against the limit.
 4. Margin value = Emission level – Limit value.
 5. The limit value is defined as per 15.247.
 6. “ * “: Fundamental frequency.

RESTRICTED BANDEDGE (DRAFT 802.11n (40MHz) MODE, CH1, HORIZONTAL)

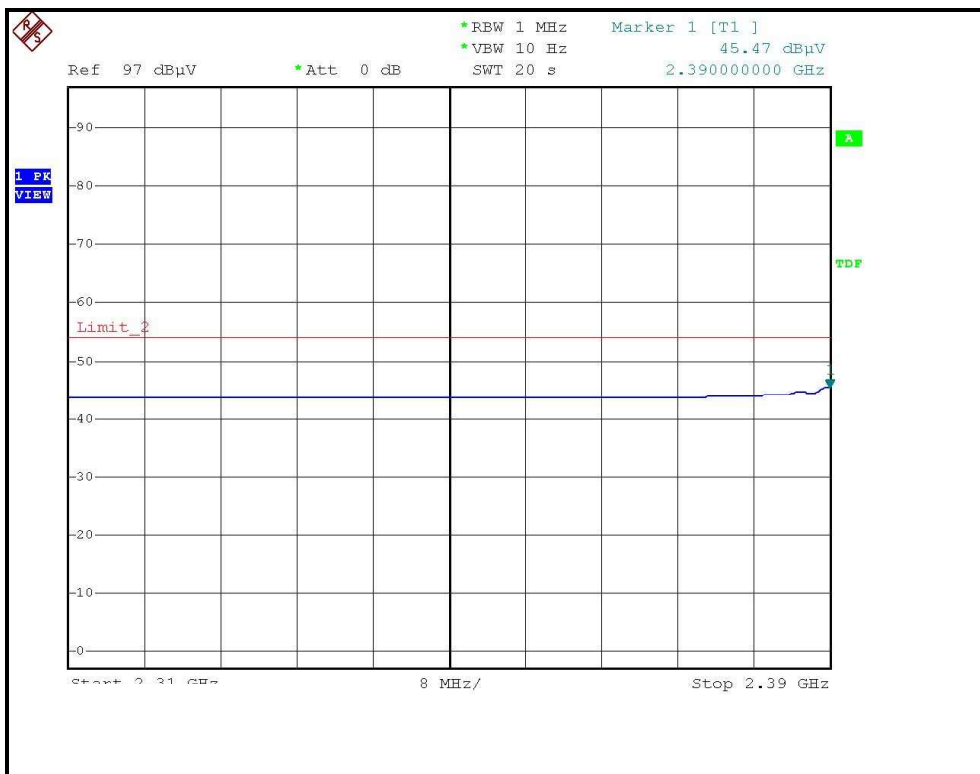
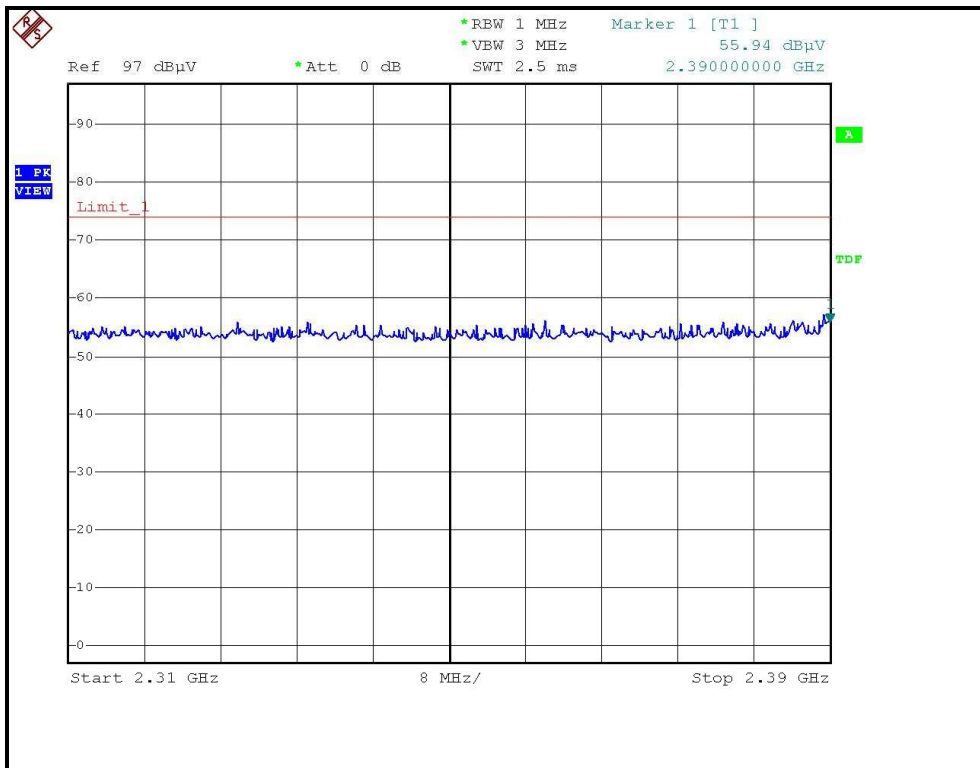

RESTRICTED BANDEDGE (DRAFT 802.11n (40MHz) MODE, CH1, VERTICAL)

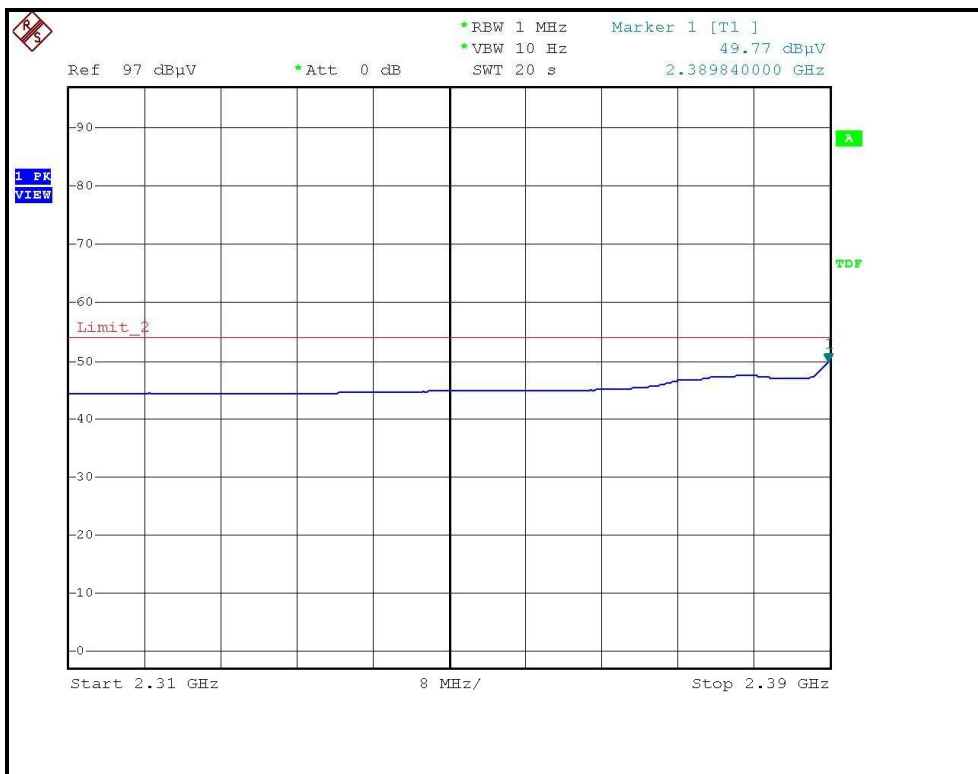
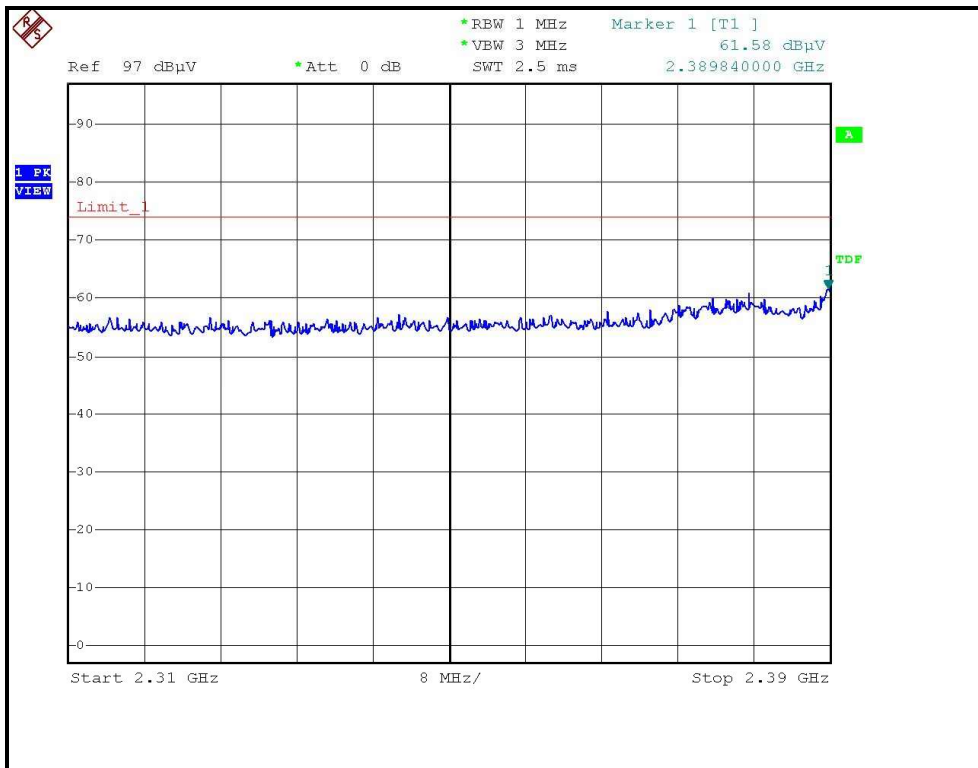



4.3 6dB BANDWIDTH MEASUREMENT

4.3.1 LIMITS OF 6dB BANDWIDTH MEASUREMENT

The minimum of 6dB Bandwidth Measurement is 0.5 MHz.

4.3.2 TEST INSTRUMENTS

Description & Manufacturer	Model No.	Serial No.	Calibrated Until
R&S SPECTRUM ANALYZER	FSP40	100037	Aug. 12, 2008

NOTE:

- 1.The measurement uncertainty is less than +/- 2.6dB, which is calculated as per the NAMAS document NIS81. This uncertainty represents an expanded uncertainty expressed at approximately the 95% confidence level using a coverage factor of k=2.
- 2.The calibration interval of the above test instruments is 12 months and the calibrations are traceable to NML/ROC and NIST/USA.

4.3.3 TEST PROCEDURE

The transmitter output was connected to the spectrum analyzer through an attenuator. The bandwidth of the fundamental frequency was measured by spectrum analyzer with 100kHz RBW and 100kHz VBW. The 6dB bandwidth is defined as the total spectrum the power of which is higher than peak power minus 6dB.

4.3.4 DEVIATION FROM TEST STANDARD

No deviation

4.3.5 TEST SETUP

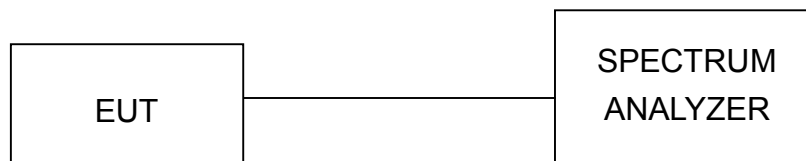

4.3.6 EUT OPERATING CONDITIONS

The software provided by client to enable the EUT under transmission condition continuously at lowest, middle and highest channel frequencies individually.

4.3.7 TEST RESULTS

802.11b DSSS MODULATION:

MODULATION TYPE	CCK	TRANSFER RATE	11Mbps
INPUT POWER (SYSTEM)	120Vac, 60 Hz	ENVIRONMENTAL CONDITIONS	25deg.C, 62%RH, 955hPa
TESTED BY	Rex Huang		

CHANNEL	CHANNEL FREQUENCY (MHz)	6dB BANDWIDTH (MHz)	MINIMUM LIMIT (MHz)	PASS / FAIL
1	2412	12.00	0.5	PASS
6	2437	11.96	0.5	PASS
11	2462	12.16	0.5	PASS

CH1

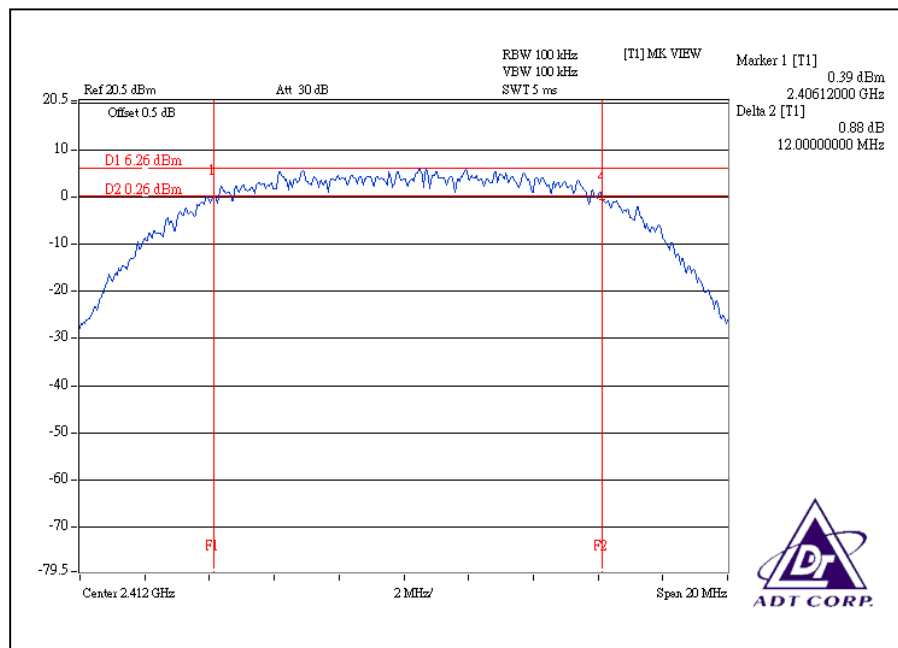

CH6

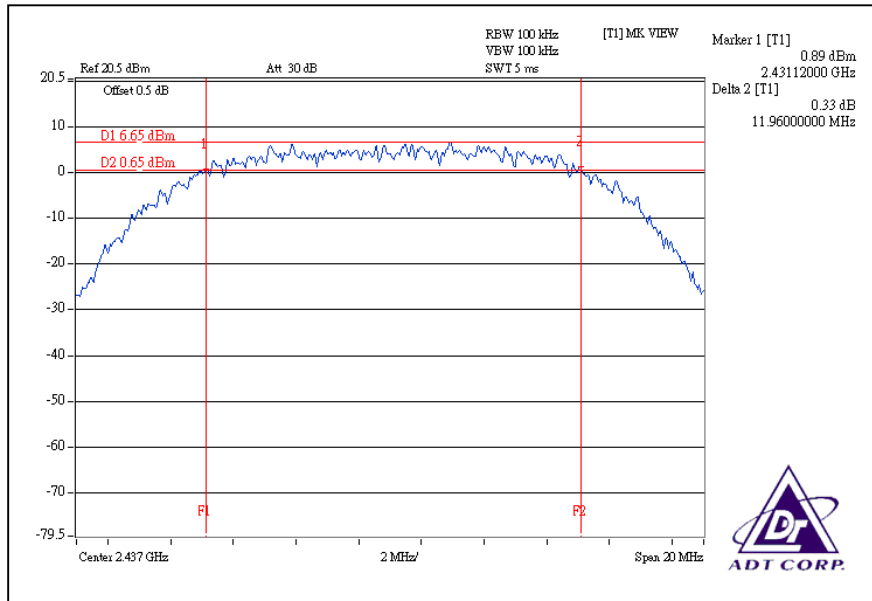

CH11

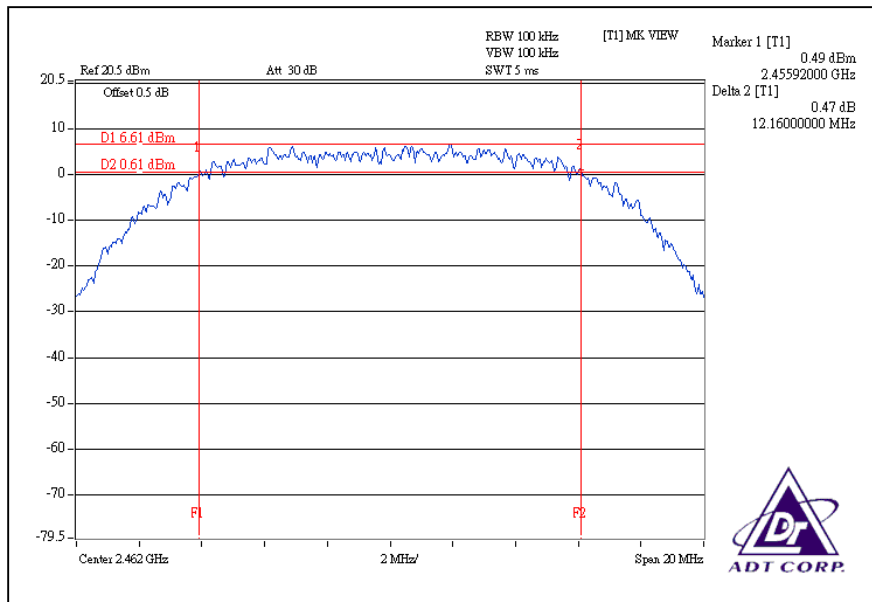

802.11g OFDM MODULATION:

MODULATION TYPE	BPSK	TRANSFER RATE	6Mbps
INPUT POWER (SYSTEM)	120Vac, 60 Hz	ENVIRONMENTAL CONDITIONS	25deg.C, 62%RH, 955hPa
TESTED BY	Rex Huang		

CHANNEL	CHANNEL FREQUENCY (MHz)	6dB BANDWIDTH (MHz)	MINIMUM LIMIT (MHz)	PASS / FAIL
1	2412	16.60	0.5	PASS
6	2437	16.56	0.5	PASS
11	2462	16.64	0.5	PASS

CH1

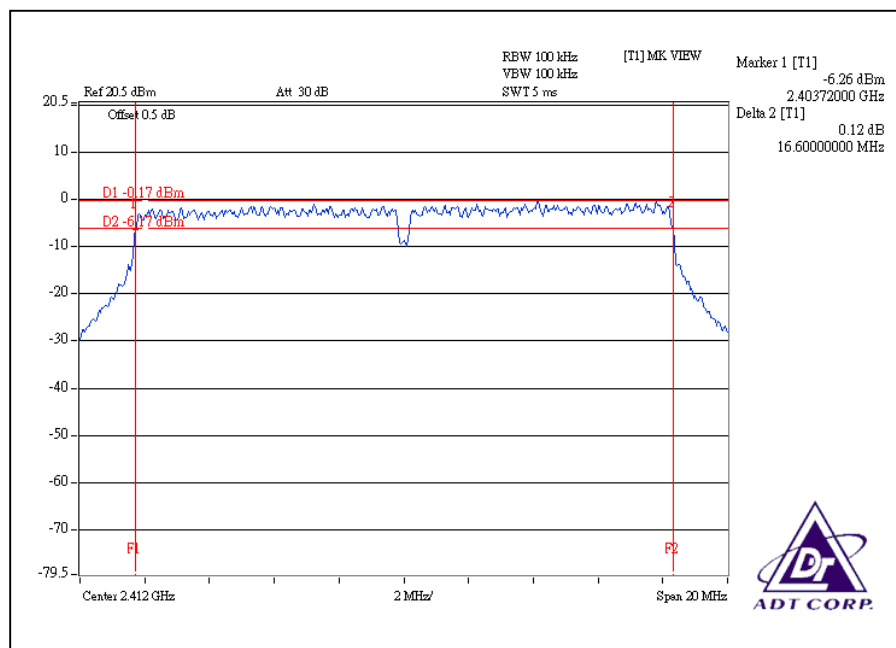

CH6

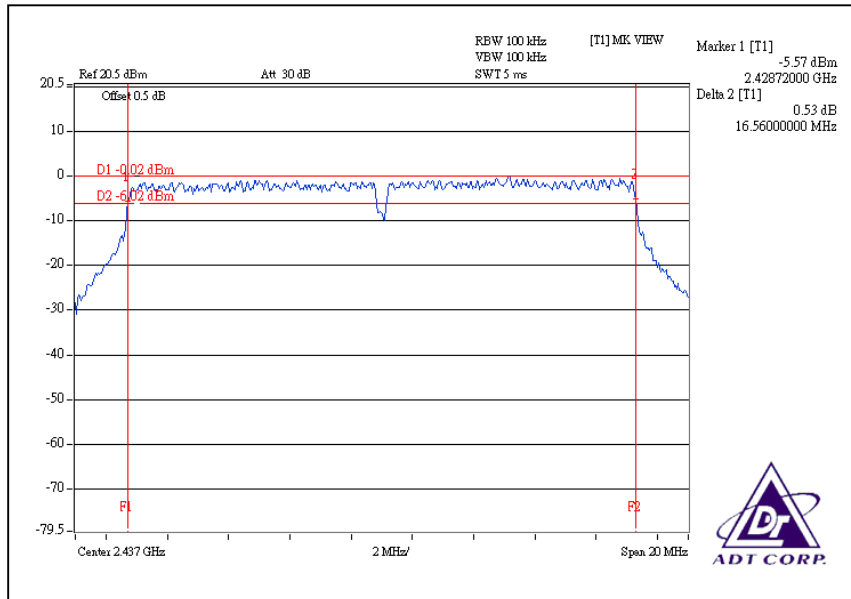

CH11

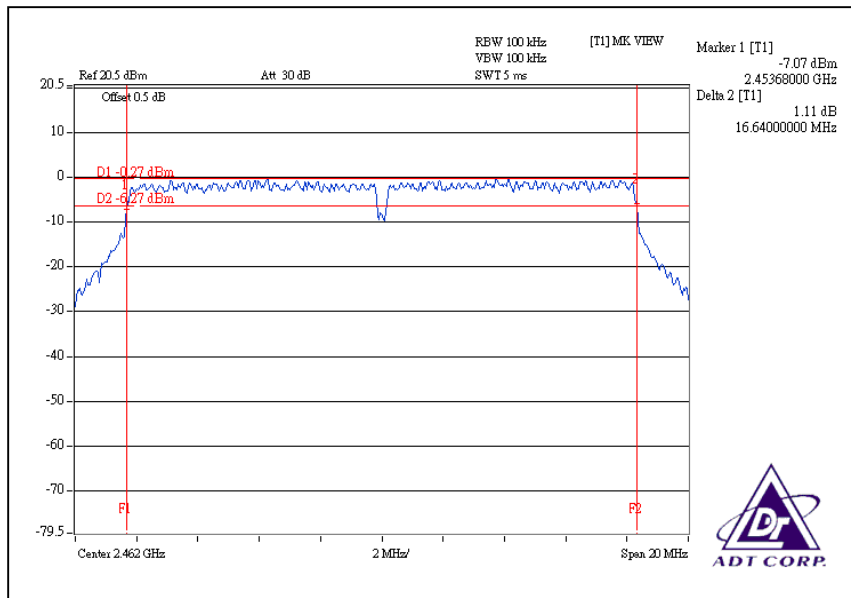

DRAFT 802.11n (20MHz) OFDM MODULATION:

MODULATION TYPE	BPSK	TRANSFER RATE	6.5Mbps
INPUT POWER (SYSTEM)	120Vac, 60 Hz	ENVIRONMENTAL CONDITIONS	25deg.C, 62%RH, 955hPa
TESTED BY	Rex Huang		

CHANNEL	CHANNEL FREQUENCY (MHz)	6dB BANDWIDTH (MHz)		MINIMUM LIMIT (MHz)	PASS / FAIL
		CHAIN(0)	CHAIN(1)		
1	2412	17.76	17.72	0.5	PASS
6	2437	17.76	17.68	0.5	PASS
11	2462	17.76	17.68	0.5	PASS

For Chain(0): CH1

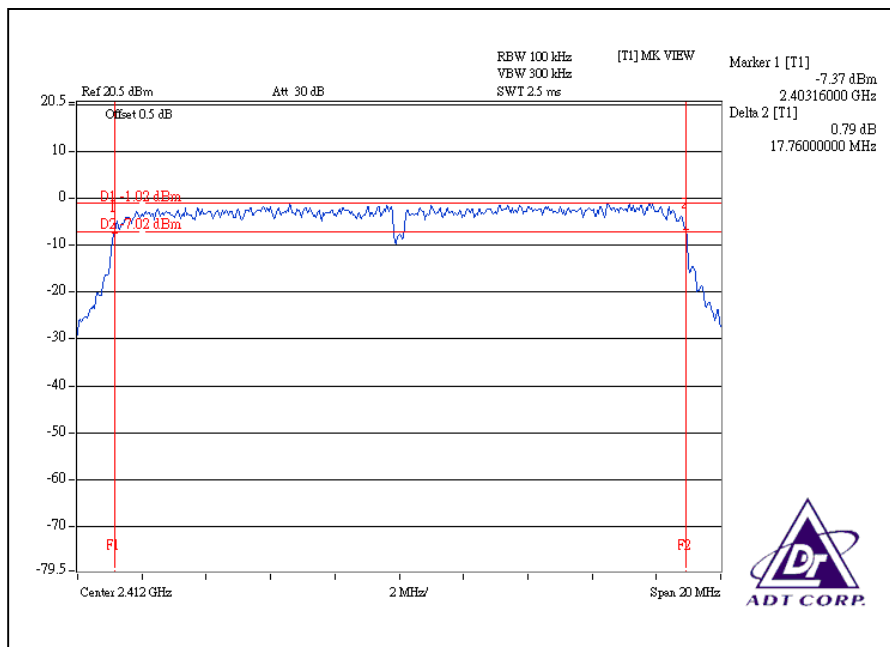

CH6

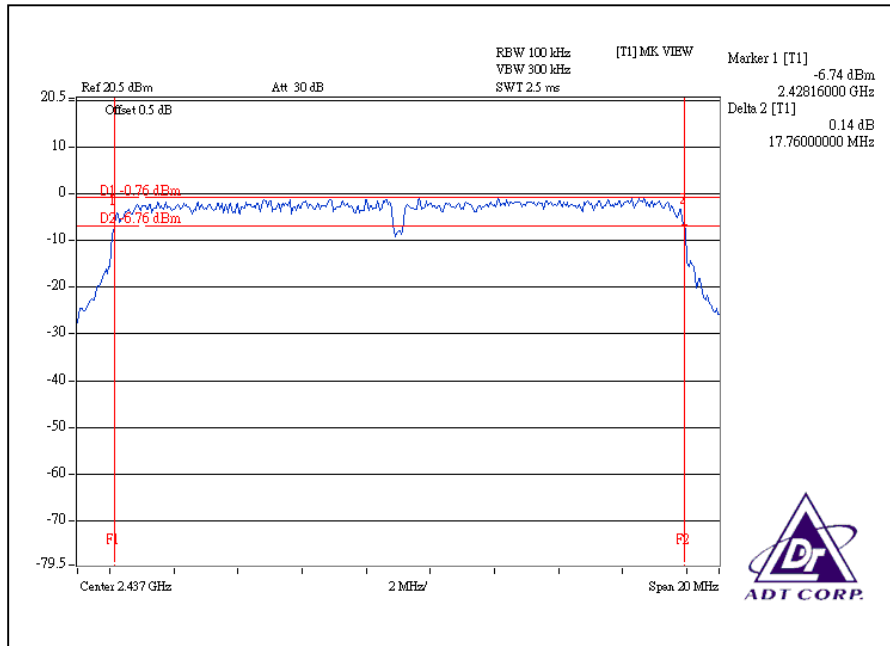

CH11

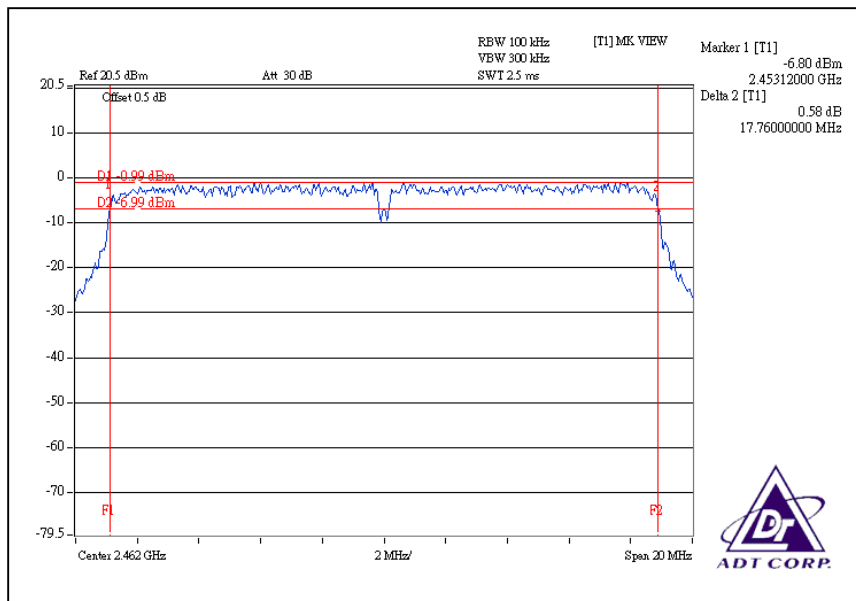

For CHAIN(1): CH1

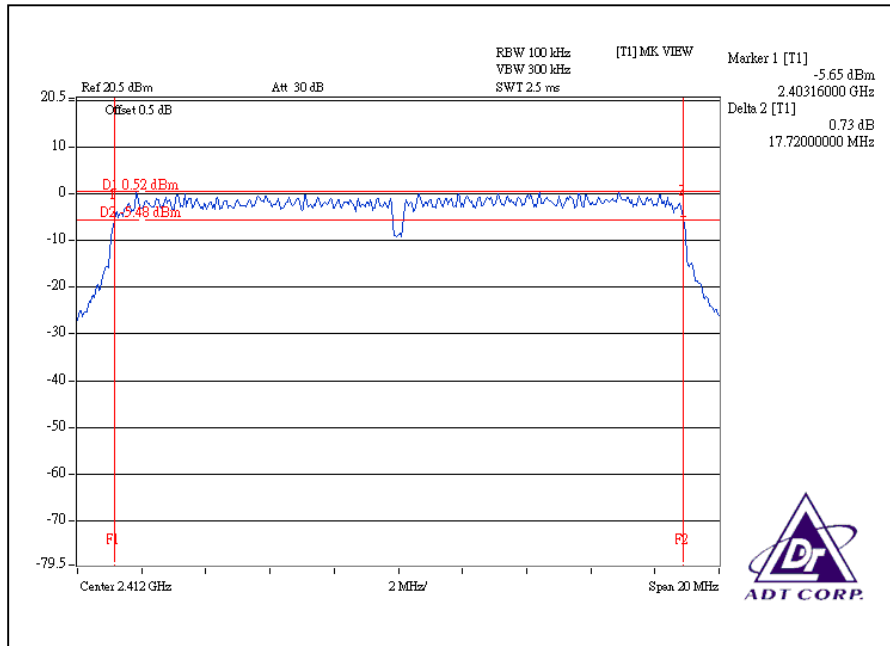

CH6

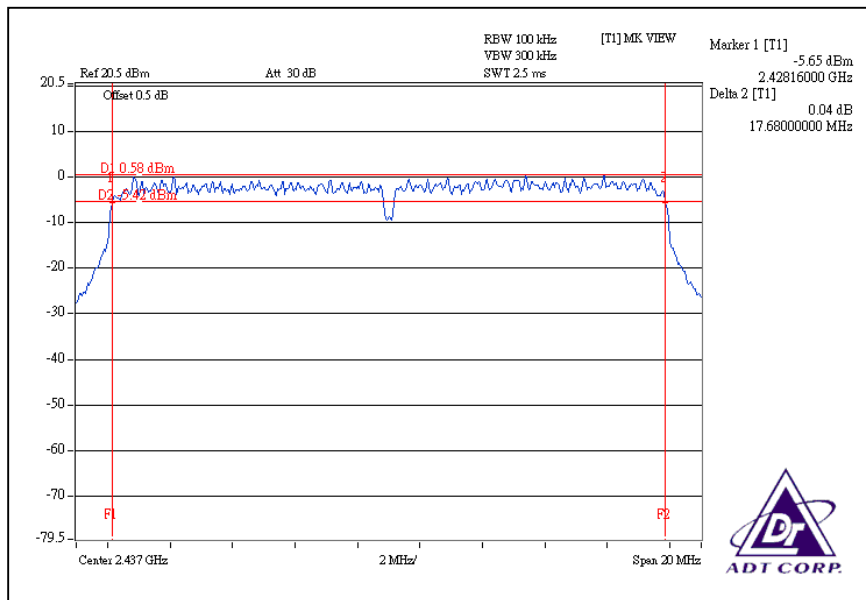

CH11

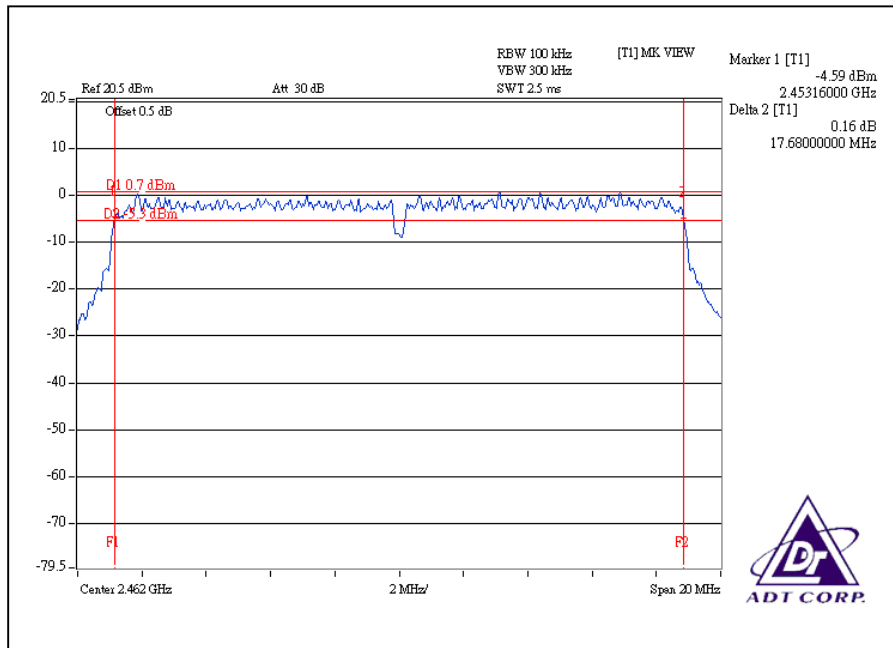

DRAFT 802.11n (40MHz) OFDM MODULATION:

MODULATION TYPE	BPSK	TRANSFER RATE	13.5Mbps
INPUT POWER (SYSTEM)	120Vac, 60 Hz	ENVIRONMENTAL CONDITIONS	25deg.C, 62%RH, 955hPa
TESTED BY	Rex Huang		

CHANNEL	CHANNEL FREQUENCY (MHz)	6dB BANDWIDTH (MHz)		MINIMUM LIMIT (MHz)	PASS / FAIL
		CHAIN(0)	CHAIN(1)		
1	2422	36.3	36.5	0.5	PASS
4	2437	36.2	36.5	0.5	PASS
7	2452	36.4	36.4	0.5	PASS

For Chain (0): CH1

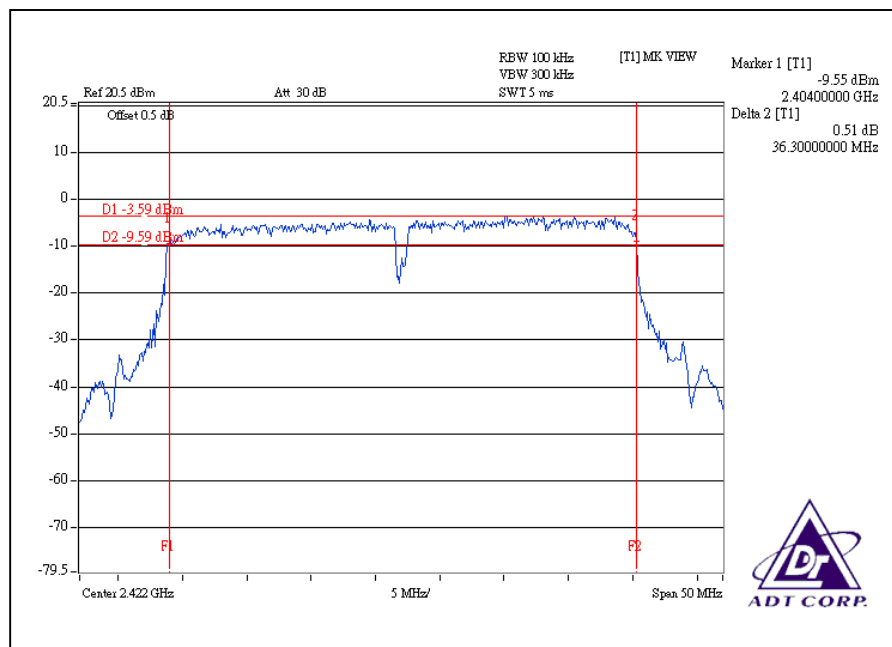

CH4

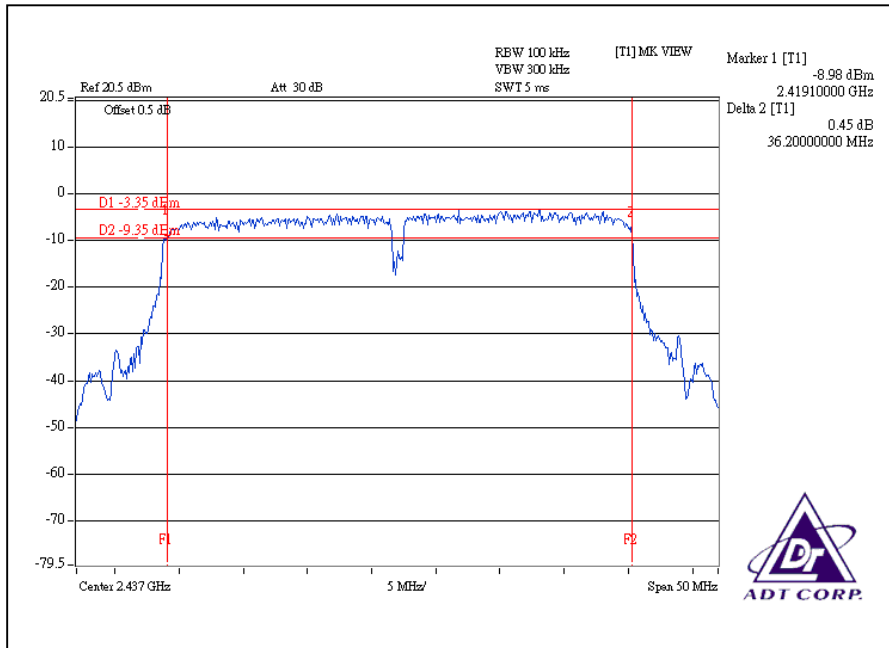

CH7

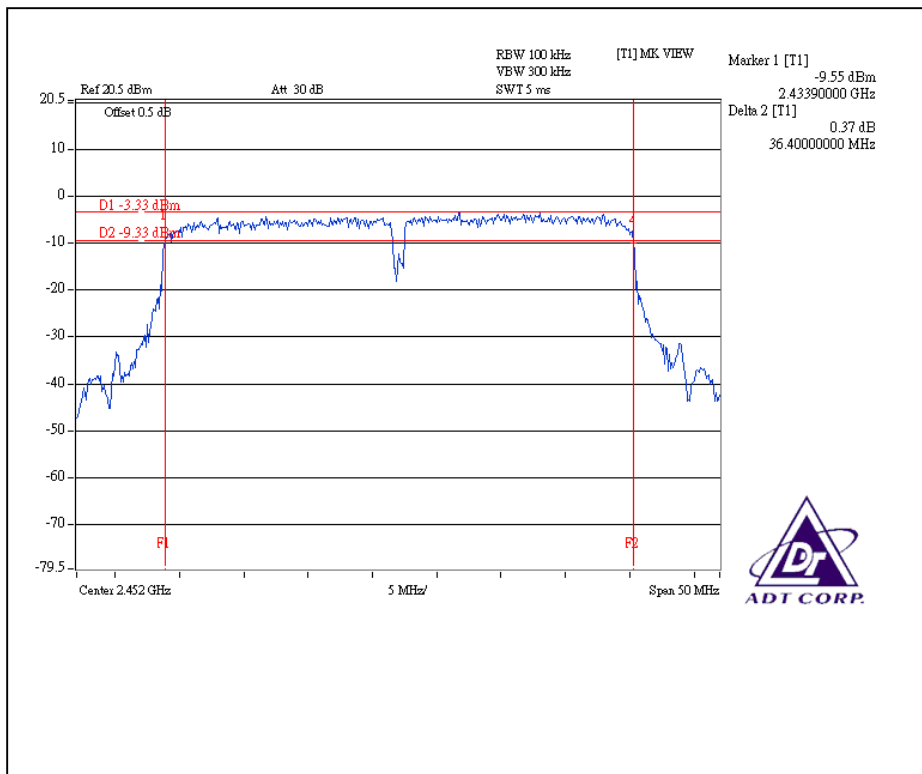

For Chain (1): CH1

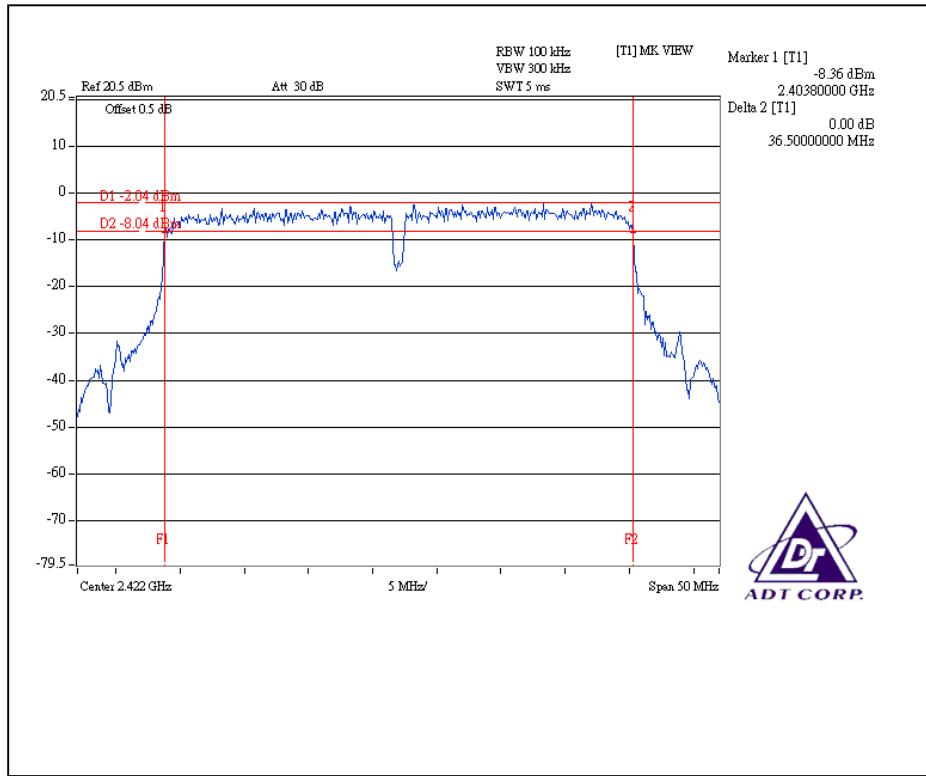

CH4

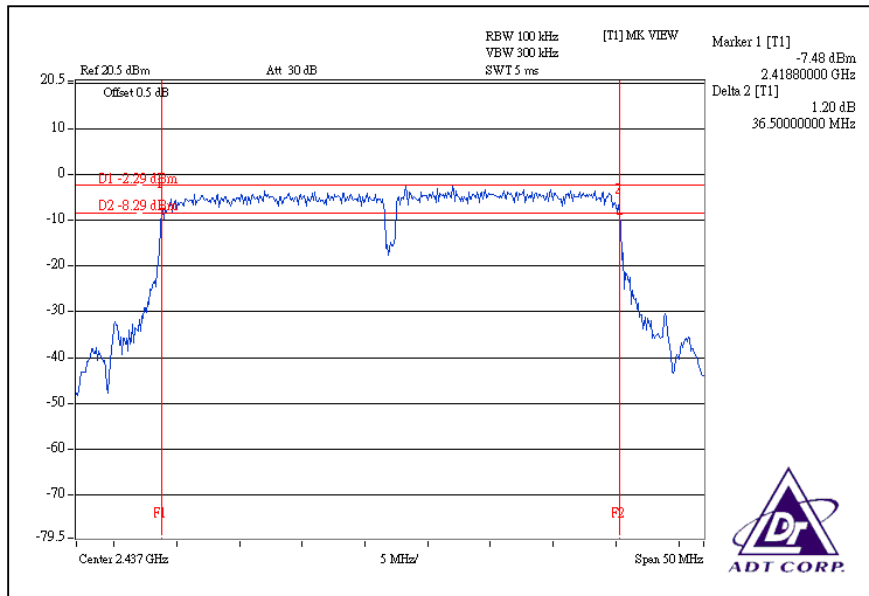

CH7

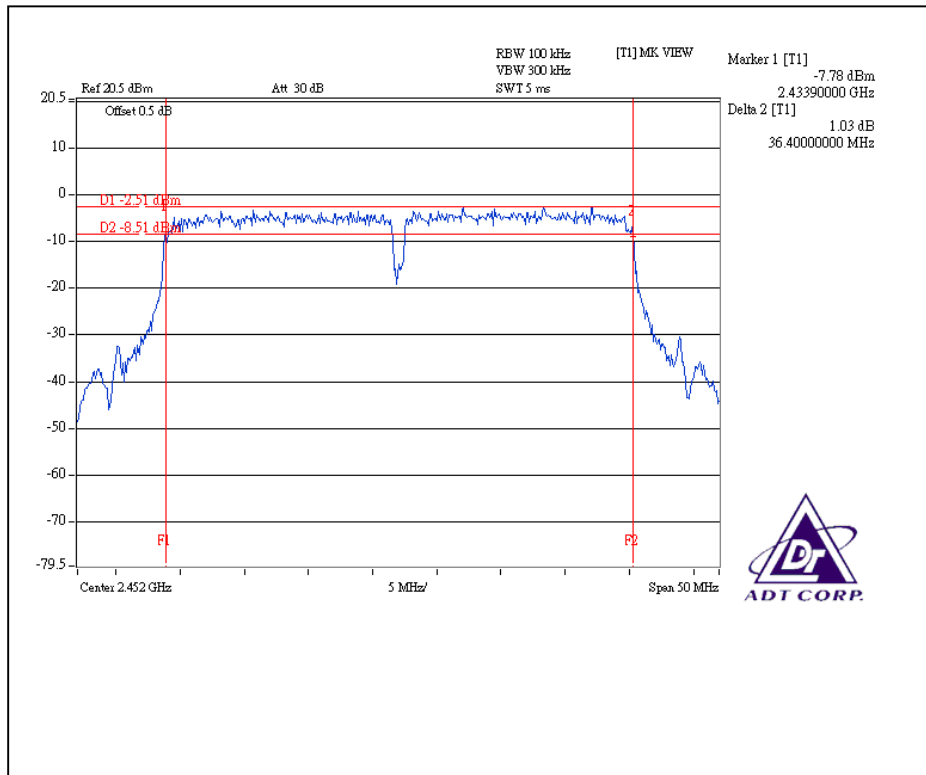

4.4 MAXIMUM PEAK OUTPUT POWER

4.4.1 LIMITS OF MAXIMUM PEAK OUTPUT POWER MEASUREMENT

The Maximum Peak Output Power Measurement is 30dBm.

4.4.2 INSTRUMENTS

Description & Manufacturer	Model No.	Serial No.	Calibrated Until
R&S SPECTRUM ANALYZER	FSP40	100037	Aug. 12, 2008
Agilent SIGNAL GENERATOR	E8257C	MY43320668	Dec. 07, 2007
TEKTRONIX OSCILLOSCOPE	TDS380	B016335	Aug. 15, 2008
NARDA DETECTOR	4503A	FSCM99899	NA

NOTE:

The calibration interval of the above test instruments is 12 months and the calibrations are traceable to NML/ROC and NIST/USA.

4.4.3 TEST PROCEDURES

1. A detector was used on the output port of the EUT. An oscilloscope was used to read the response of the detector.
2. Replaced the EUT by the signal generator. The center frequency of the S.G was adjusted to the center frequency of the measured channel.
3. Adjusted the power to have the same reading on oscilloscope. Record the power level.

4.4.4 DEVIATION FROM TEST STANDARD

No deviation

4.4.5 TEST SETUP



4.4.6 EUT OPERATING CONDITIONS

Same as Item 4.3.6

4.4.7 TEST RESULTS

802.11b DSSS MODULATION:

MODULATION TYPE	CCK	TRANSFER RATE	11Mbps
INPUT POWER (SYSTEM)	120Vac, 60 Hz	ENVIRONMENTAL CONDITIONS	25deg.C, 62%RH, 955hPa
TESTED BY	Rex Huang		

CHANNEL	CHANNEL FREQUENCY (MHz)	PEAK POWER OUTPUT (mW)	PEAK POWER OUTPUT (dBm)	PEAK POWER LIMIT (dBm)	PASS / FAIL
1	2412	112.202	20.50	30	PASS
6	2437	118.850	20.75	30	PASS
11	2462	118.850	20.75	30	PASS

802.11g OFDM MODULATION:

MODULATION TYPE	BPSK	TRANSFER RATE	6Mbps
INPUT POWER (SYSTEM)	120Vac, 60 Hz	ENVIRONMENTAL CONDITIONS	25deg.C, 62%RH, 955hPa
TESTED BY	Rex Huang		

CHANNEL	CHANNEL FREQUENCY (MHz)	PEAK POWER OUTPUT (mW)	PEAK POWER OUTPUT (dBm)	PEAK POWER LIMIT (dBm)	PASS / FAIL
1	2412	95.499	19.80	30	PASS
6	2437	105.925	20.25	30	PASS
11	2462	105.925	20.25	30	PASS

DRAFT 802.11n (20MHz) OFDM MODULATION:

MODULATION TYPE	BPSK	TRANSFER RATE	6.5Mbps
INPUT POWER (SYSTEM)	120Vac, 60 Hz	ENVIRONMENTAL CONDITIONS	25deg.C, 62%RH, 955hPa
TESTED BY	Rex Huang		

CHANNEL	CHANNEL FREQUENCY (MHz)	PEAK POWER OUTPUT (mW)		PEAK POWER OUTPUT (dBm)		TOTAL PEAK POWER (mW)	TOTAL PEAK POWER (dBm)	PEAK POWER LIMIT (dBm)	PASS / FAIL
		CHAIN(0)	CHAIN(1)	CHAIN(0)	CHAIN(1)				
1	2412	83.176	100.000	19.20	20.00	183.176	22.63	30	PASS
6	2437	91.201	91.201	19.60	19.60	182.402	22.61	30	PASS
11	2462	91.201	95.499	19.60	19.80	186.700	22.71	30	PASS

DRAFT 802.11n (40MHz) OFDM MODULATION:

MODULATION TYPE	BPSK	TRANSFER RATE	13.5Mbps
INPUT POWER (SYSTEM)	120Vac, 60 Hz	ENVIRONMENTAL CONDITIONS	25deg.C, 62%RH, 955hPa
TESTED BY	Rex Huang		

CHANNEL	CHANNEL FREQUENCY (MHz)	PEAK POWER OUTPUT (mW)		PEAK POWER OUTPUT (dBm)		TOTAL PEAK POWER (mW)	TOTAL PEAK POWER (dBm)	PEAK POWER LIMIT (dBm)	PASS / FAIL
		CHAIN(0)	CHAIN(1)	CHAIN(0)	CHAIN(1)				
1	2422	68.077	79.433	18.33	19.00	147.510	21.69	30	PASS
4	2437	73.621	73.621	18.67	18.67	147.242	21.68	30	PASS
7	2452	73.621	73.621	18.67	18.67	147.242	21.68	30	PASS



4.5 POWER SPECTRAL DENSITY MEASUREMENT

4.5.1 LIMITS OF POWER SPECTRAL DENSITY MEASUREMENT

The Maximum of Power Spectral Density Measurement is 8dBm.

4.5.2 TEST INSTRUMENTS

Description & Manufacturer	Model No.	Serial No.	Calibrated Until
R&S SPECTRUM ANALYZER	FSP40	100037	Sep. 06, 2008

NOTE:

- 1.The measurement uncertainty is less than +/- 2.6dB, which is calculated as per the NAMAS document NIS81. This uncertainty represents an expanded uncertainty expressed at approximately the 95% confidence level using a coverage factor of k=2.
- 2.The calibration interval of the above test instruments is 12 months and the calibrations are traceable to NML/ROC and NIST/USA.

4.5.3 TEST PROCEDURE

The transmitter output was connected to the spectrum analyzer through an attenuator, the bandwidth of the fundamental frequency was measured with the spectrum analyzer using 3kHz RBW and 30kHz VBW, set sweep time = span/3kHz. The power spectral density was measured and recorded. The sweep time is allowed to be longer than span/3kHz for a full response of the mixer in the spectrum analyzer.

4.5.4 DEVIATION FROM TEST STANDARD

No deviation

4.5.5 TEST SETUP

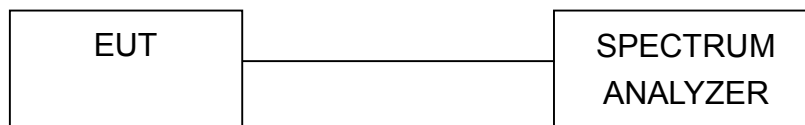

4.5.6 EUT OPERATING CONDITION

Same as Item 4.3.6

4.5.7 TEST RESULTS

802.11b DSSS MODULATION:

MODULATION TYPE	CCK	TRANSFER RATE	11Mbps
INPUT POWER (SYSTEM)	120Vac, 60 Hz	ENVIRONMENTAL CONDITIONS	25deg.C, 62%RH, 955hPa
TESTED BY	Rex Huang		

CHANNEL	CHANNEL FREQUENCY (MHz)	RF POWER LEVEL IN 3kHz BW (dBm)	MAXIMUM LIMIT (dBm)	PASS / FAIL
1	2412	-6.59	8	PASS
6	2437	-6.23	8	PASS
11	2462	-6.29	8	PASS

CH1

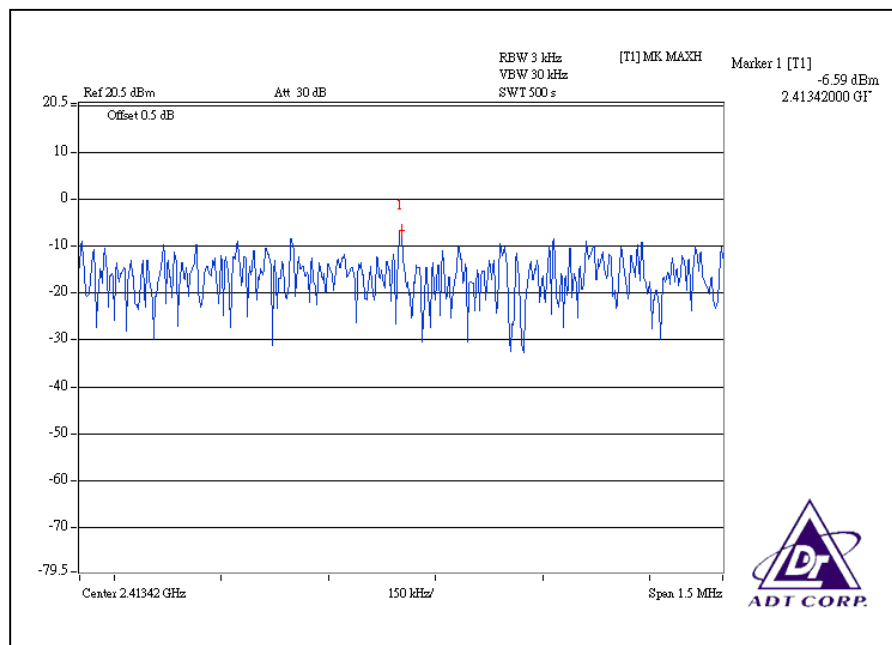

CH6

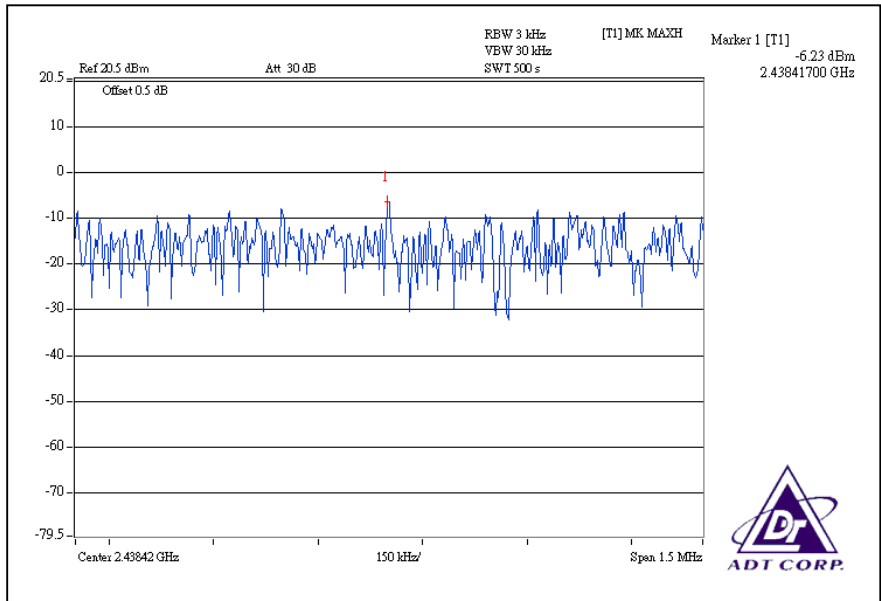

CH11

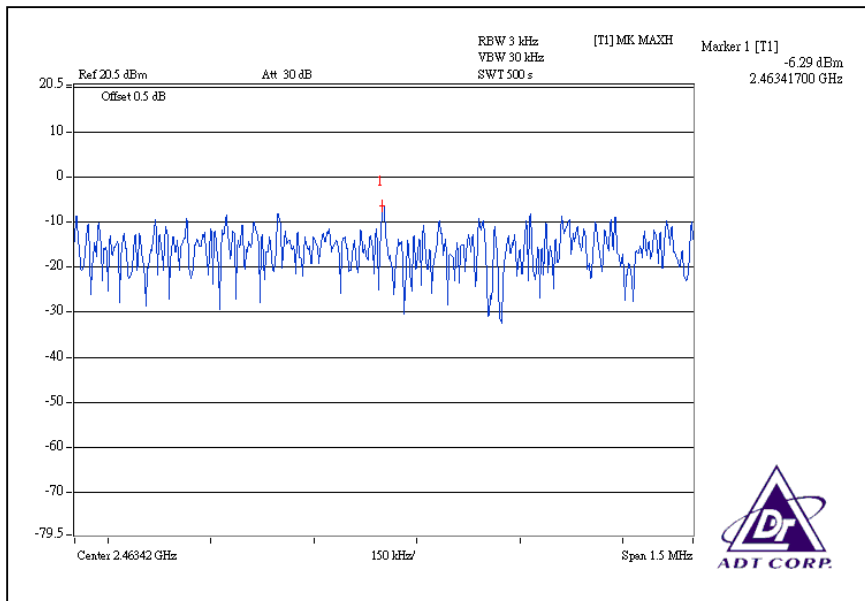

802.11g OFDM MODULATION:

MODULATION TYPE	BPSK	TRANSFER RATE	6Mbps
INPUT POWER (SYSTEM)	120Vac, 60 Hz	ENVIRONMENTAL CONDITIONS	25deg.C, 62%RH, 955hPa
TESTED BY	Rex Huang		

CHANNEL	CHANNEL FREQUENCY (MHz)	RF POWER LEVEL IN 3kHz BW (dBm)	MAXIMUM LIMIT (dBm)	PASS / FAIL
1	2412	-14.72	8	PASS
6	2437	-14.52	8	PASS
11	2462	-14.44	8	PASS

CH1

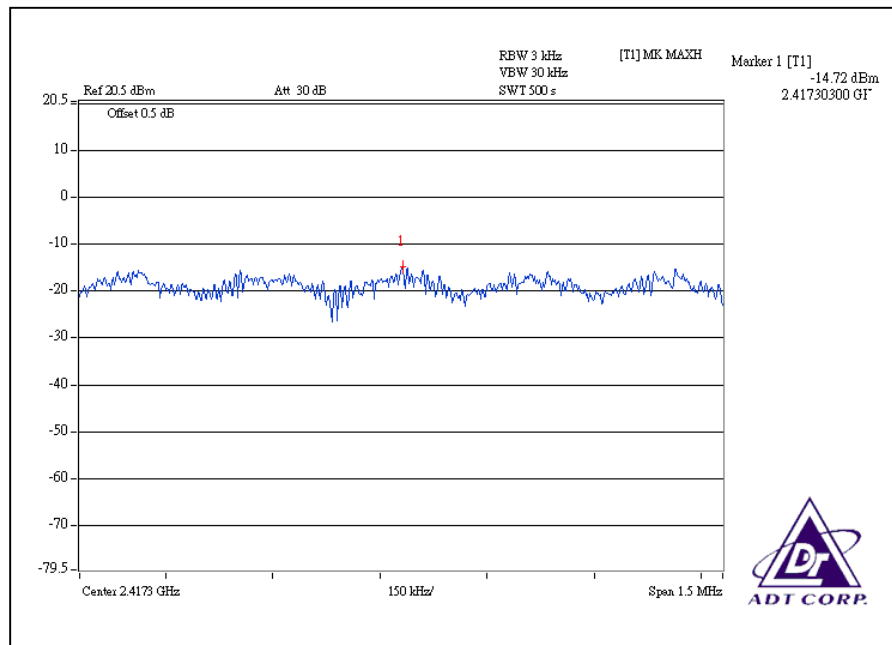

CH6

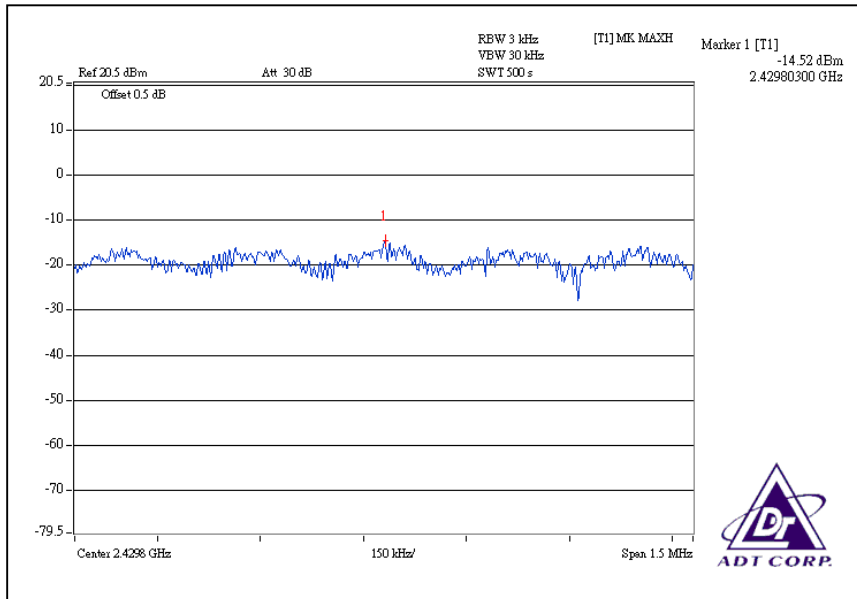

CH11

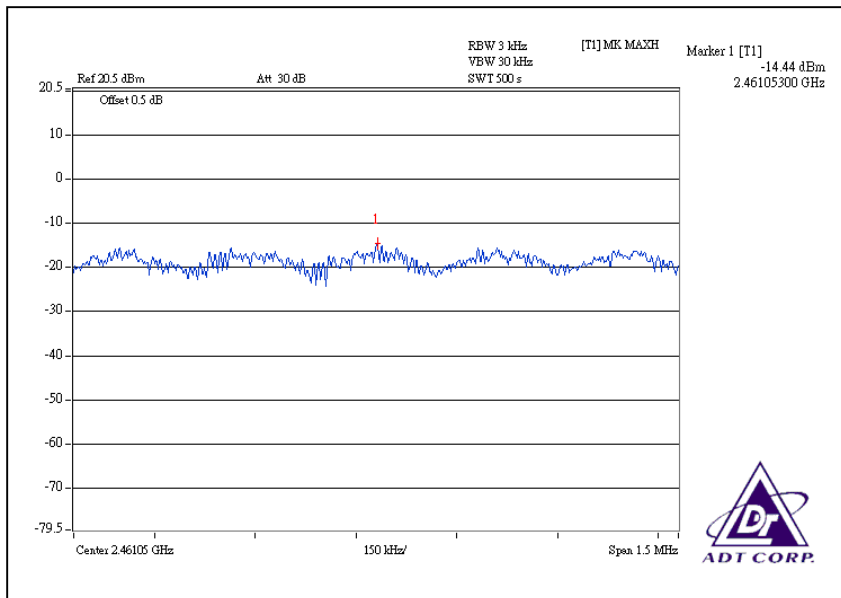

DRAFT 802.11n (20MHz) OFDM MODULATION:

MODULATION TYPE	BPSK	TRANSFER RATE	6.5Mbps
INPUT POWER (SYSTEM)	120Vac, 60 Hz	ENVIRONMENTAL CONDITIONS	25 deg.C, 62%RH, 955hPa
TESTED BY	Rex Huang		

CHANNEL	CHANNEL FREQUENCY (MHz)	RF POWER LEVEL IN 3kHz BW (mW)		RF POWER LEVEL IN 3kHz BW (dBm)		TOTAL POWER DENSITY (mW)	TOTAL POWER DENSITY (dBm)	MAXIMUM LIMIT (dBm)	PASS / FAIL
		CHAIN(0)	CHAIN(1)	CHAIN(0)	CHAIN(1)				
1	2412	0.038	0.049	-14.15	-13.11	0.087	-10.60	8	PASS
6	2437	0.041	0.038	-13.85	-14.20	0.079	-11.02	8	PASS
11	2462	0.037	0.041	-14.26	-13.91	0.078	-11.08	8	PASS

For Chain(0): CH1

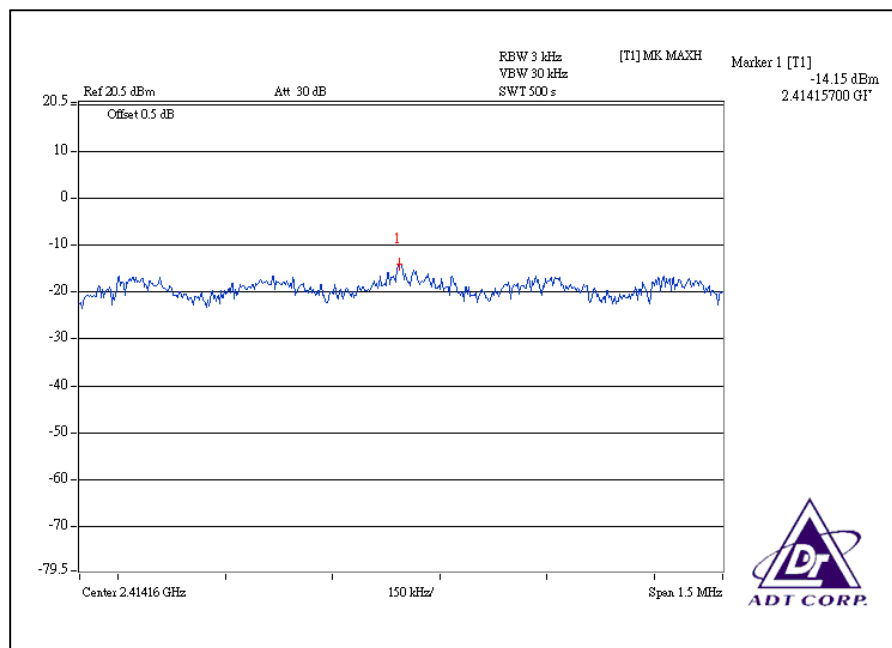

CH6

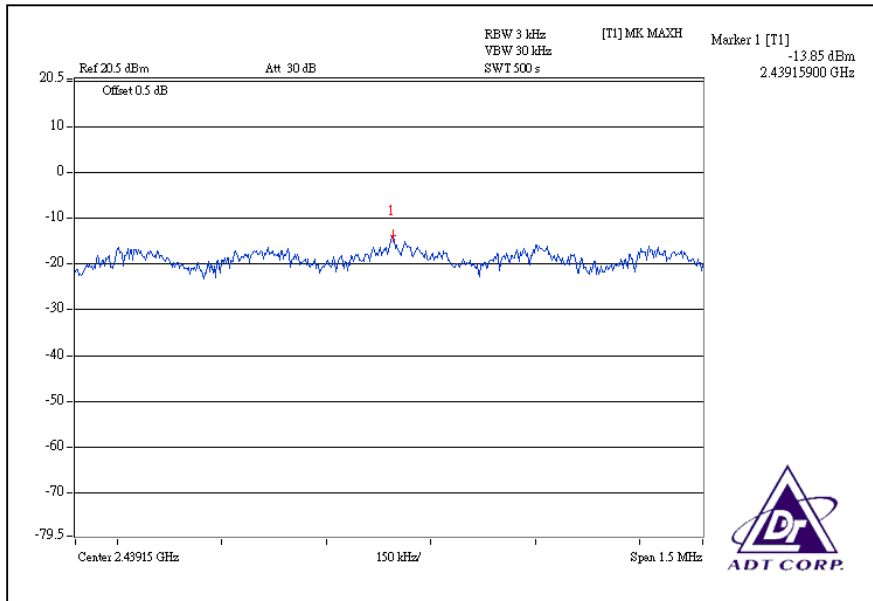

CH11

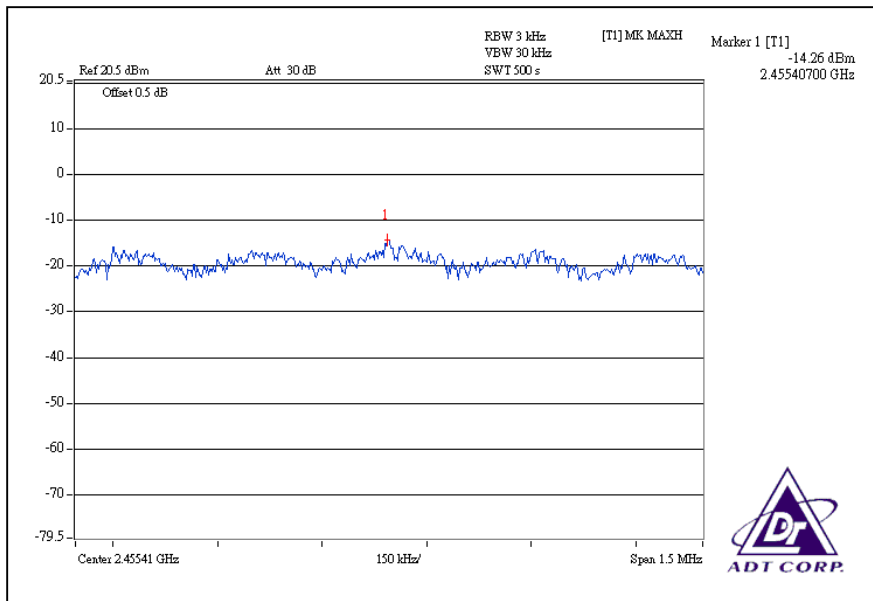

For Chain (1): CH1

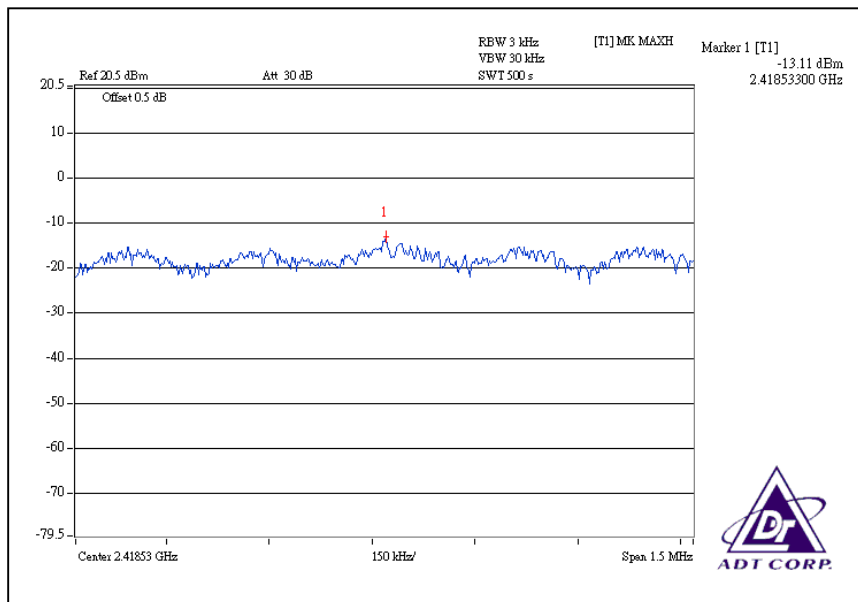

CH6

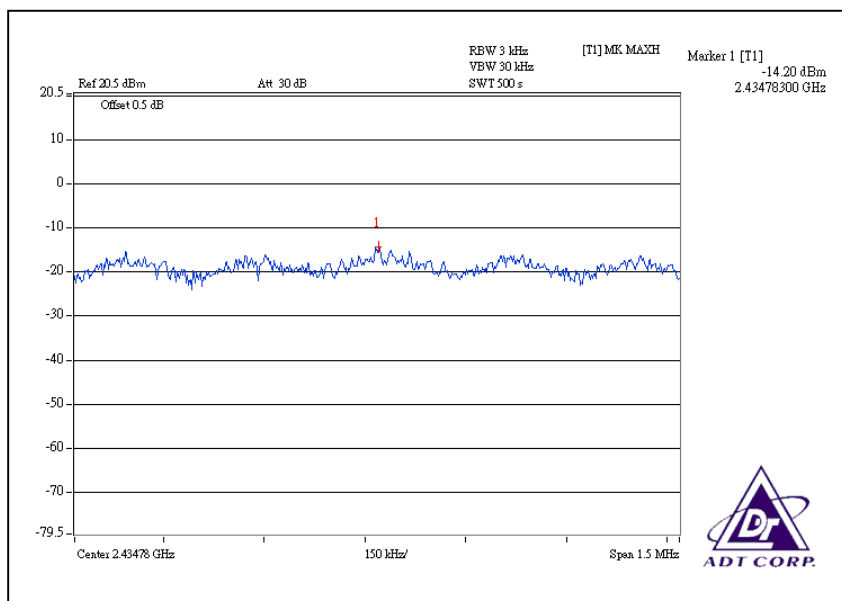

CH11

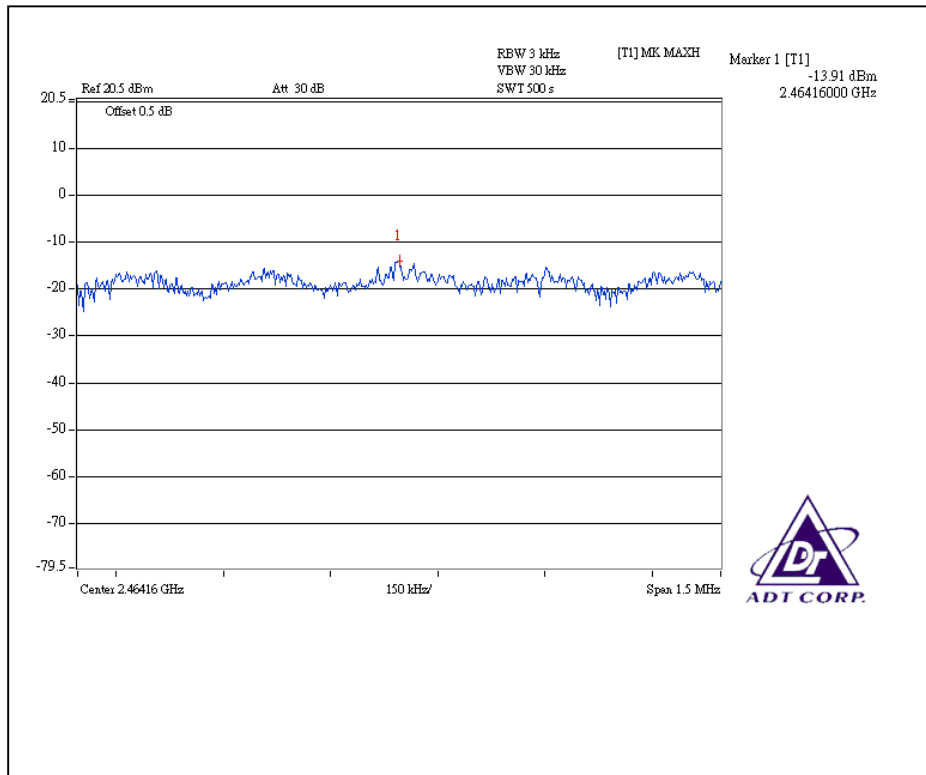

DRAFT 802.11n (40MHz) OFDM MODULATION:

MODULATION TYPE	BPSK	TRANSFER RATE	13.5Mbps
INPUT POWER (SYSTEM)	120Vac, 60 Hz	ENVIRONMENTAL CONDITIONS	25deg.C, 62%RH, 955hPa
TESTED BY	Rex Huang		

CHANNEL	CHANNEL FREQUENCY (MHz)	RF POWER LEVEL IN 3kHz BW (mW)		RF POWER LEVEL IN 3kHz BW (dBm)		TOTAL POWER DENSITY (mW)	TOTAL POWER DENSITY (dBm)	MAXIMUM LIMIT (dBm)	PASS / FAIL
		CHAIN(0)	CHAIN(1)	CHAIN(0)	CHAIN(1)				
1	2422	0.024	0.020	-16.24	-16.91	0.044	-13.57	8	PASS
4	2437	0.018	0.018	-17.34	-17.34	0.036	-14.44	8	PASS
7	2452	0.024	0.020	-16.20	-16.97	0.044	-13.57	8	PASS

For Chain (0): CH1

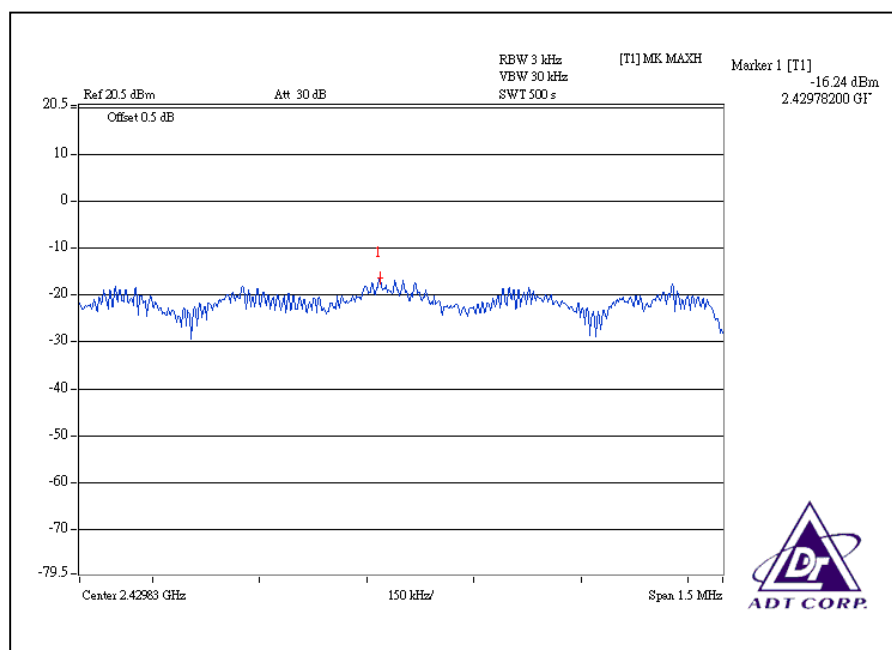

CH4

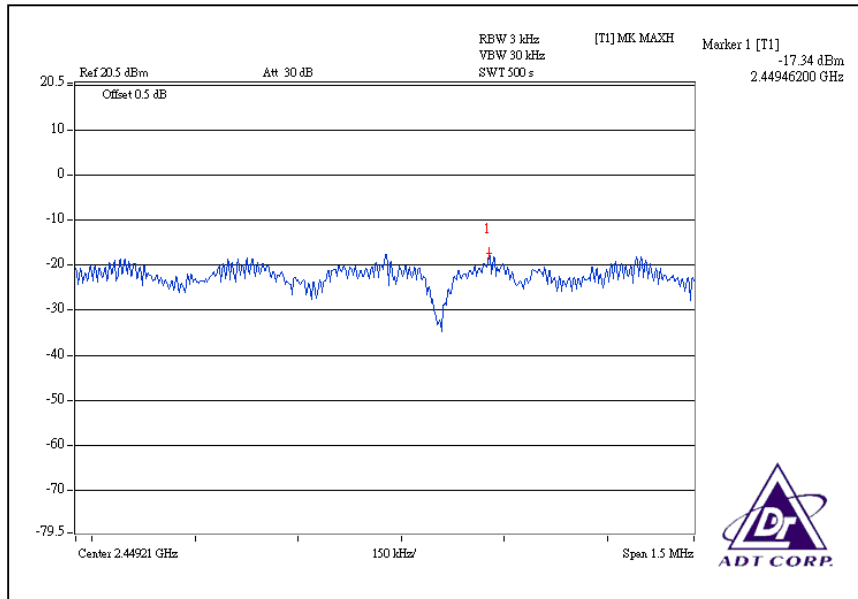

CH7

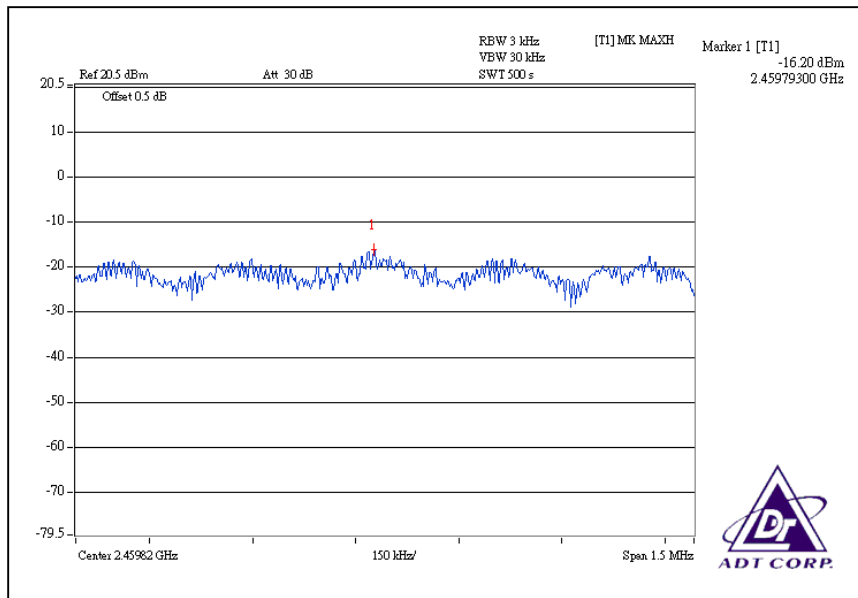

For Chain (1): CH1

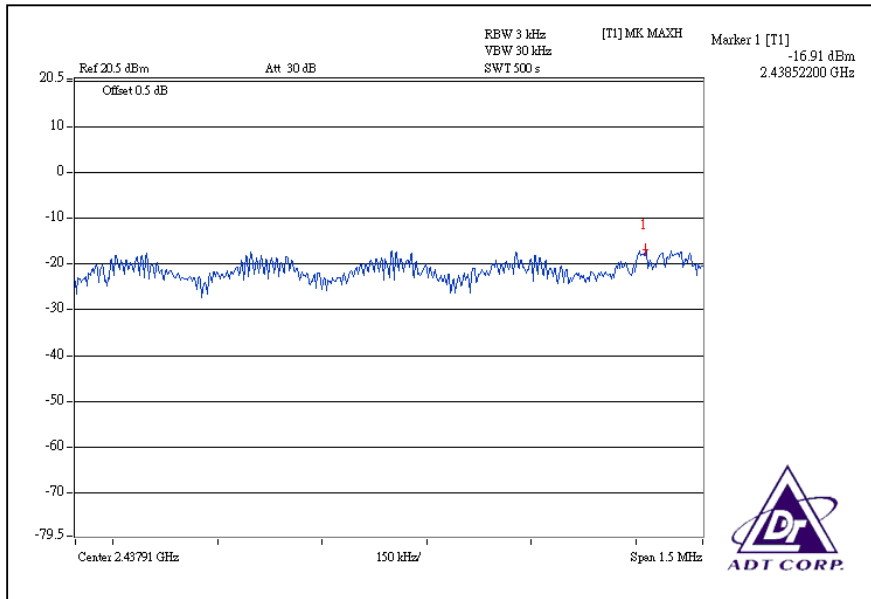

CH4

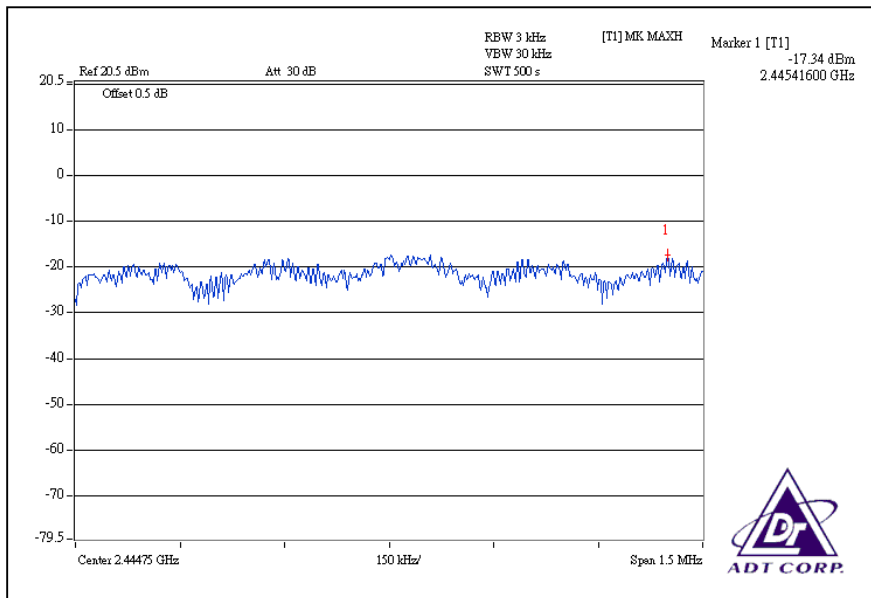

CH7

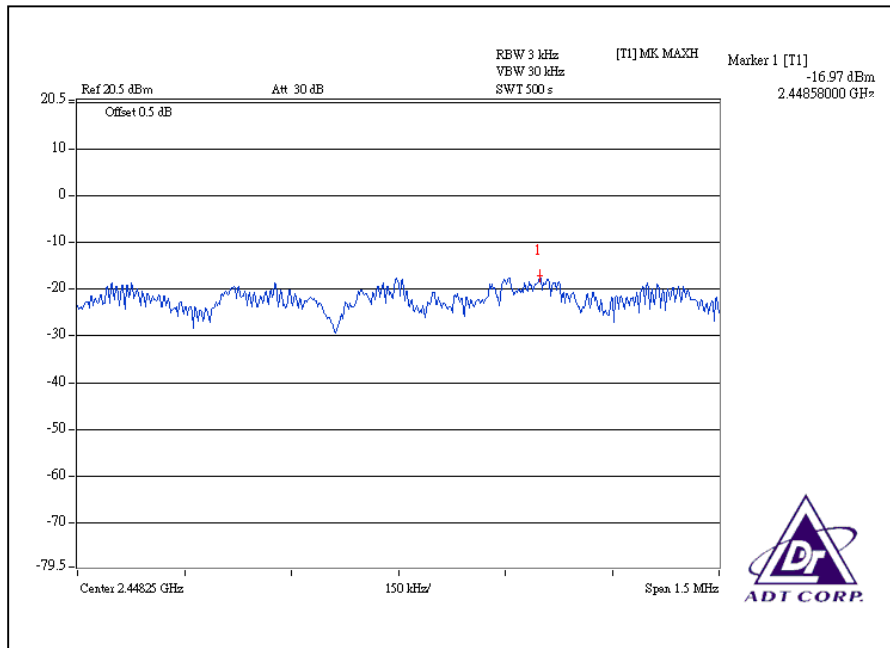



4.6 BAND EDGES MEASUREMENT

4.6.1 LIMITS OF BAND EDGES MEASUREMENT

Below -20dB of the highest emission level of operating band (in 100KHz Resolution Bandwidth).

4.6.2 TEST INSTRUMENTS

Description & Manufacturer	Model No.	Serial No.	Calibrated Until
R&S SPECTRUM ANALYZER	FSP40	100037	Nov. 12, 2008

NOTE:

- 1.The measurement uncertainty is less than $\pm 2.6\text{dB}$, which is calculated as per the NAMAS document NIS81. This uncertainty represents an expanded uncertainty expressed at approximately the 95% confidence level using a coverage factor of $k=2$.
- 2.The calibration interval of the above test instruments is 12 months and the calibrations are traceable to NML/ROC and NIST/USA.

4.6.3 TEST PROCEDURE

The transmitter output was connected to the spectrum analyzer via a low lose cable. Set both RBW and VBW of spectrum analyzer to 100kHz with suitable frequency span including 100 MHz bandwidth from band edge. The band edges was measured and recorded.

The spectrum plots (RBW = VBW = 100kHz) are attached on the following pages.

4.6.4 DEVIATION FROM TEST STANDARD

No deviation

4.6.5 EUT OPERATING CONDITION

Same as Item 4.3.6

4.6.6 TEST RESULTS

The spectrum plots are attached on the following 12 images. D1 line indicates the highest level, and D2 line indicates the 20dB offset below D1. It shows compliance with the requirement in part 15.247(d).

802.11b DSSS MODULATION: CH1

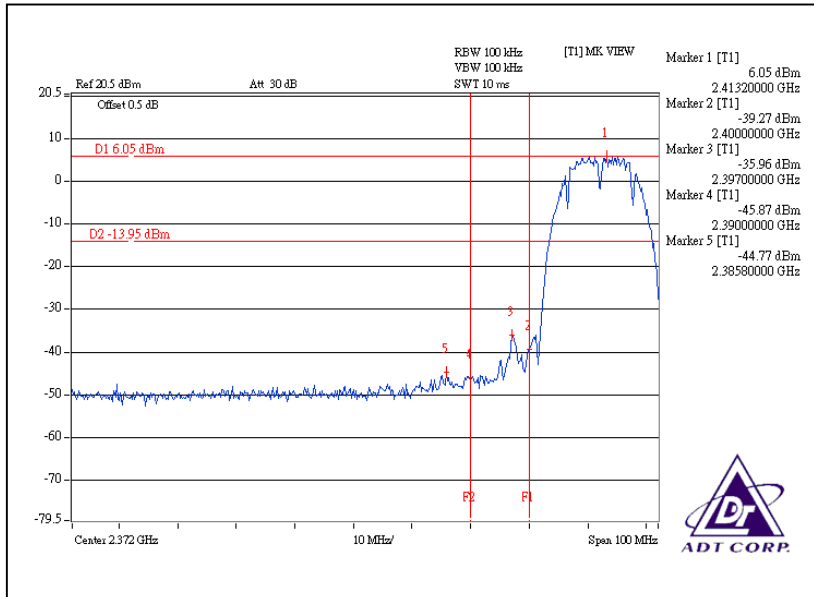

CH11

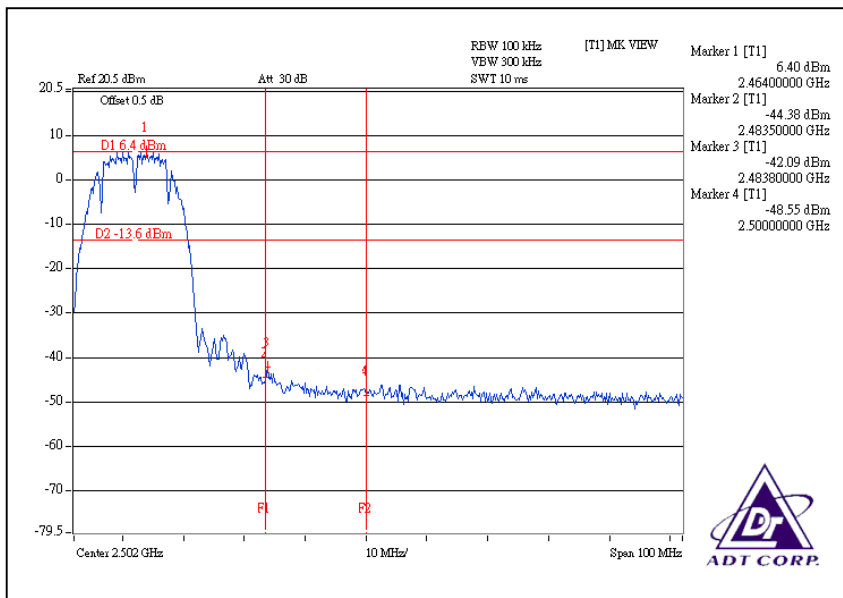

CH1

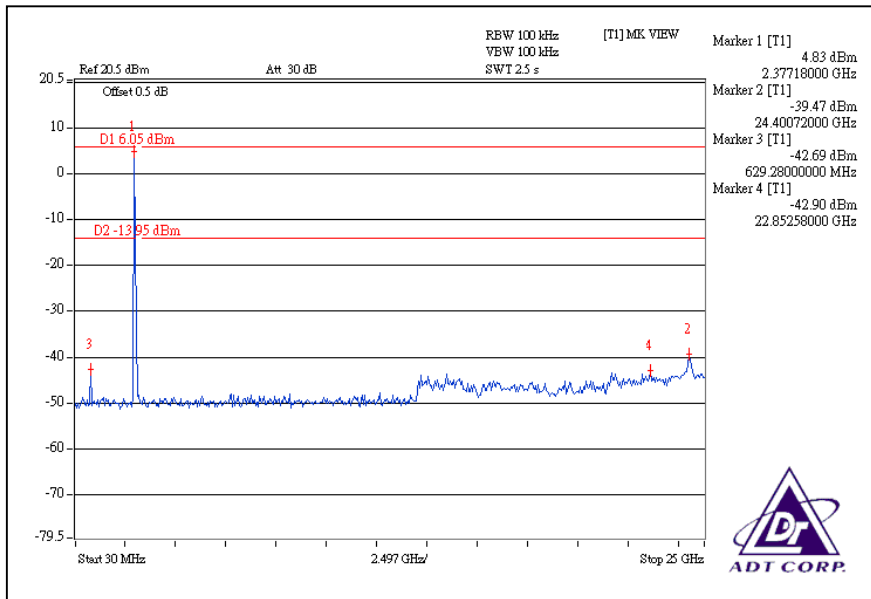

CH11

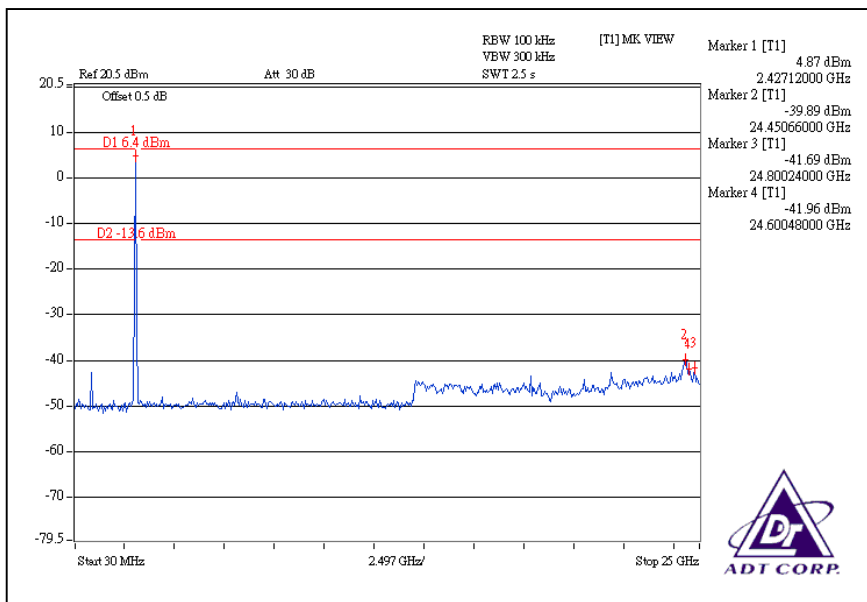

802.11g OFDM MODULATION:

CH 1

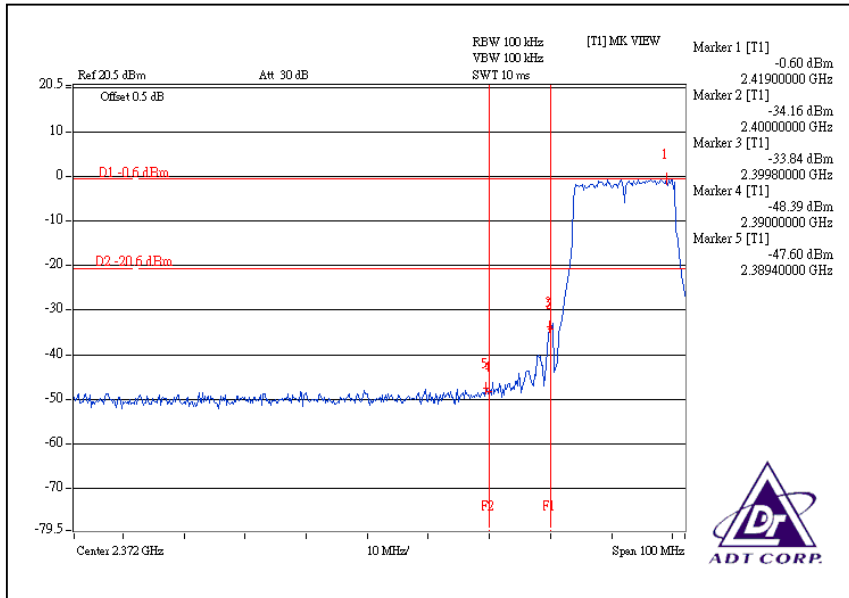

CH11

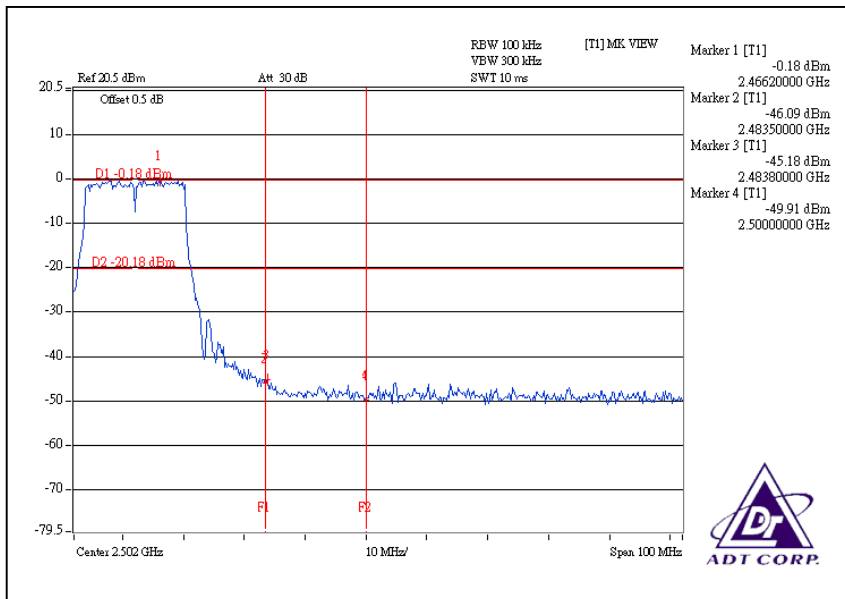

CH1

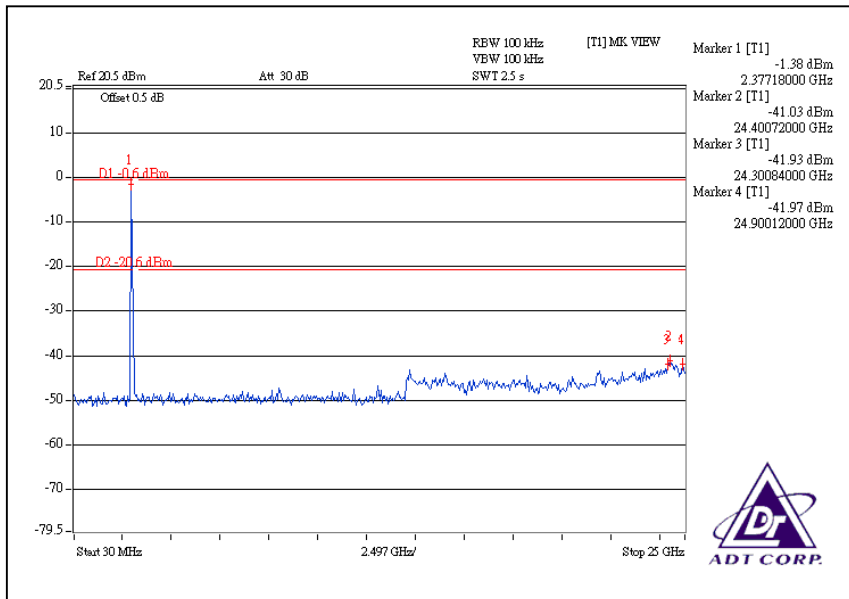

CH11

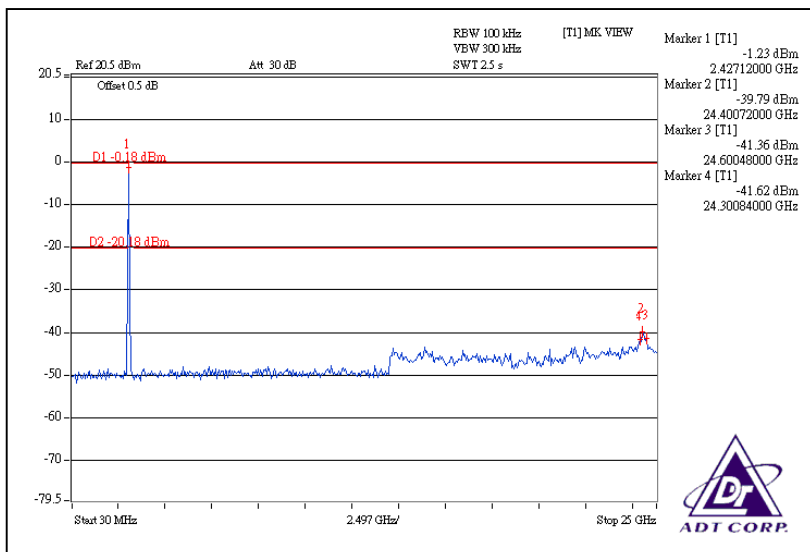

DRAFT 802.11n (20MHz) OFDM MODULATION: For Chain (0):CH1

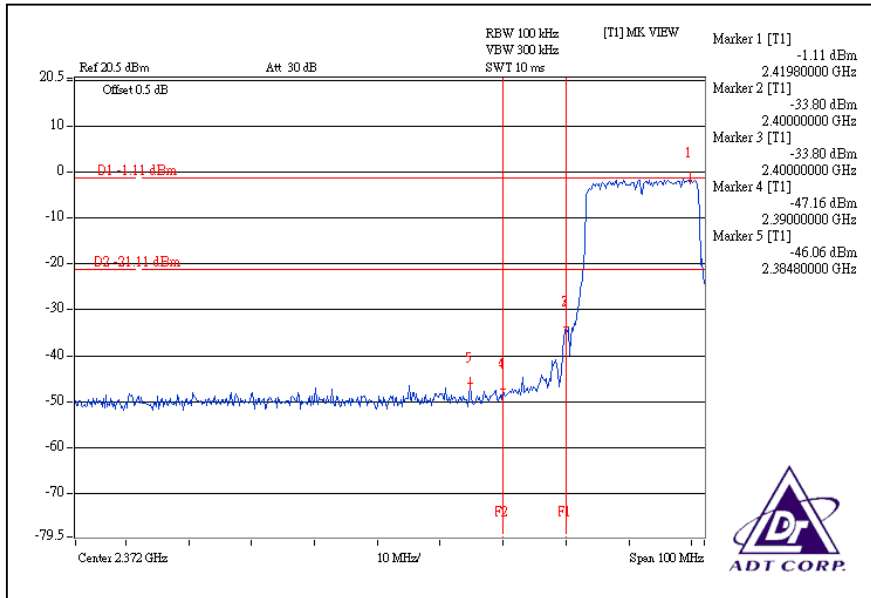

CH11

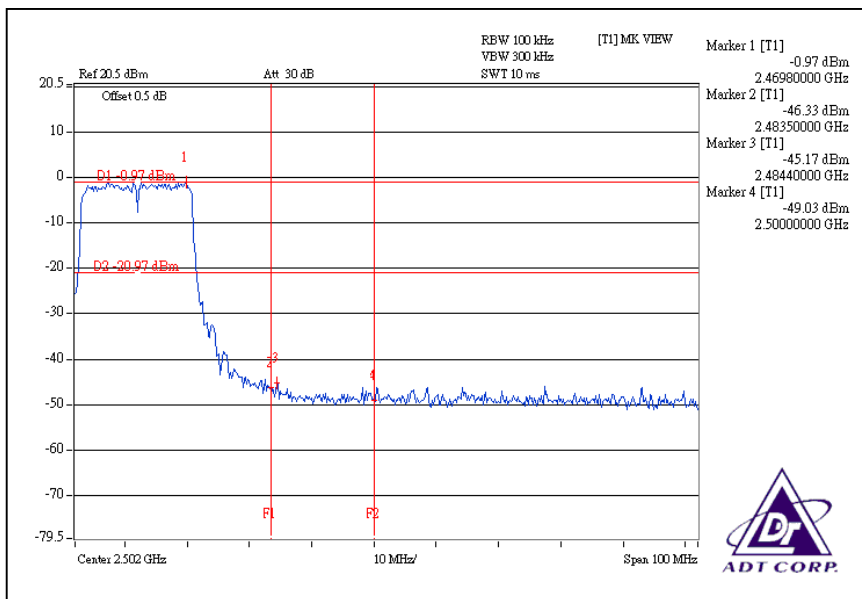

CH1

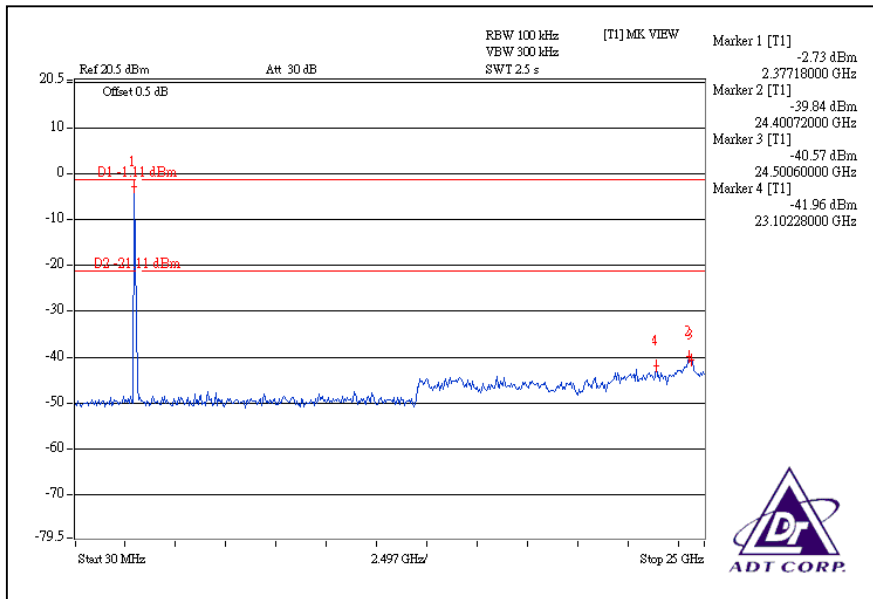

CH11

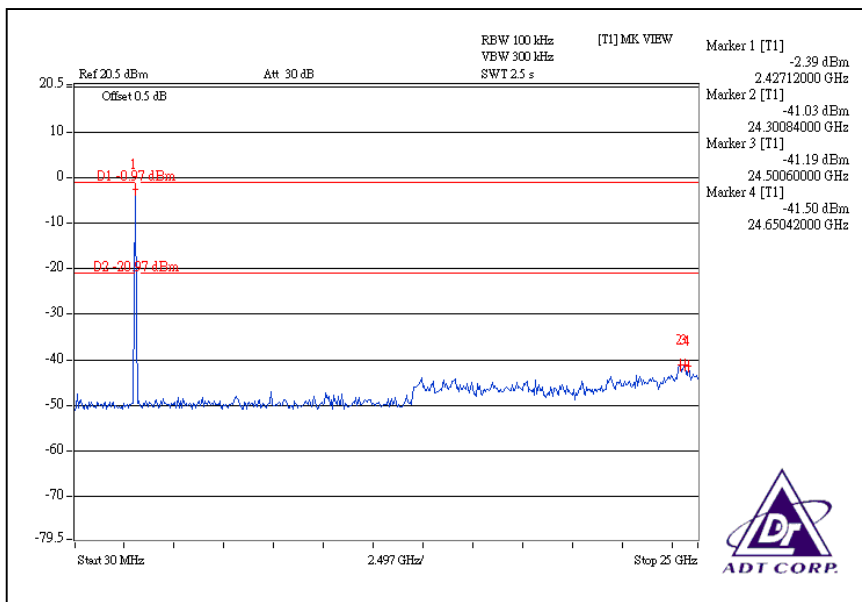

For Chain (1):CH1

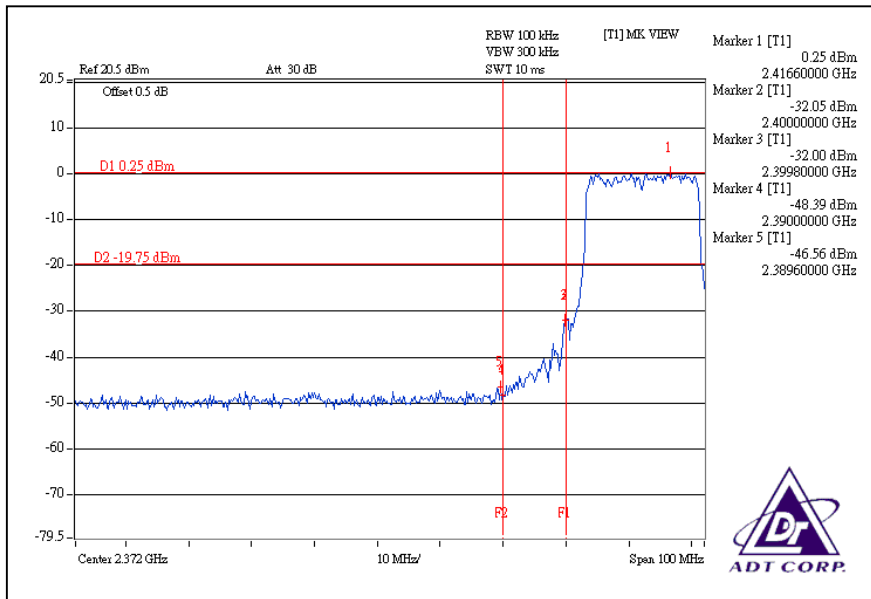

CH11

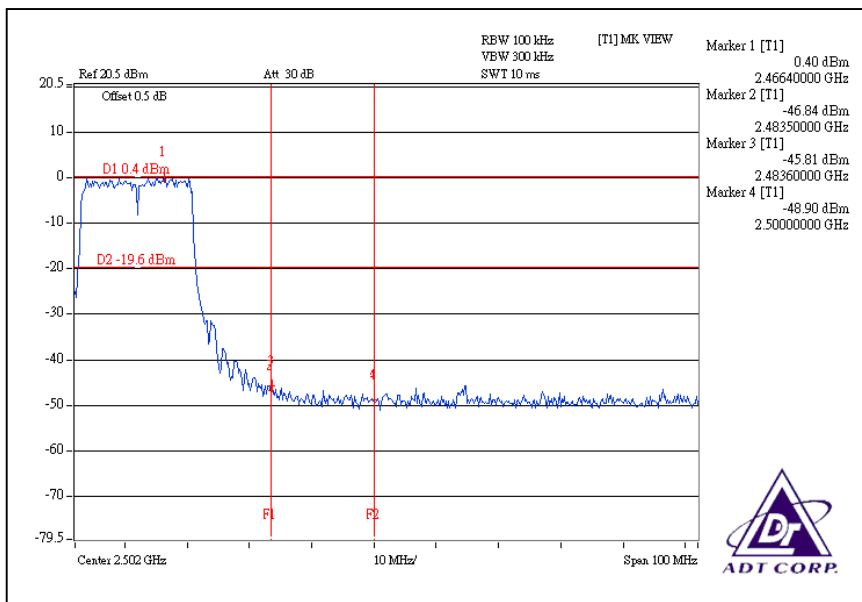

DRAFT 802.11n (40MHz) OFDM MODULATION:
For Chain (0):CH1

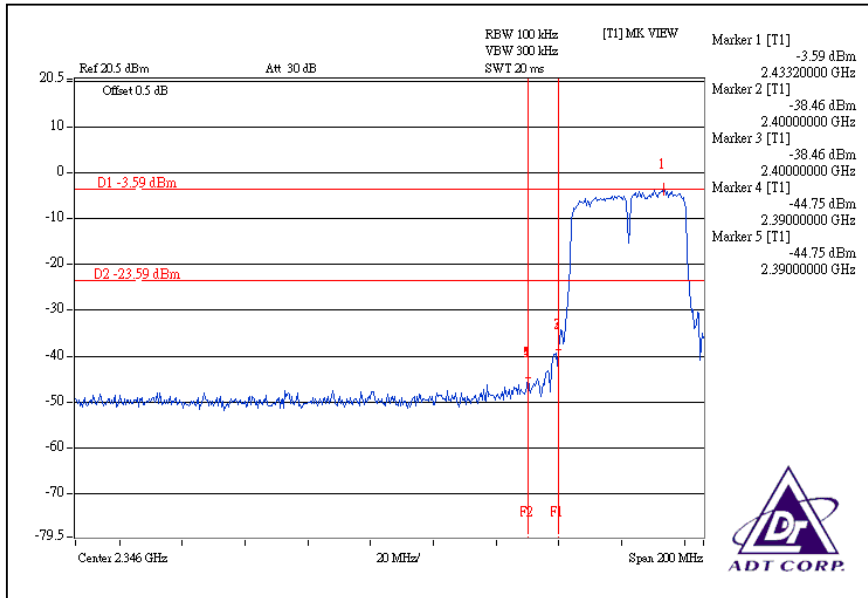

CH7

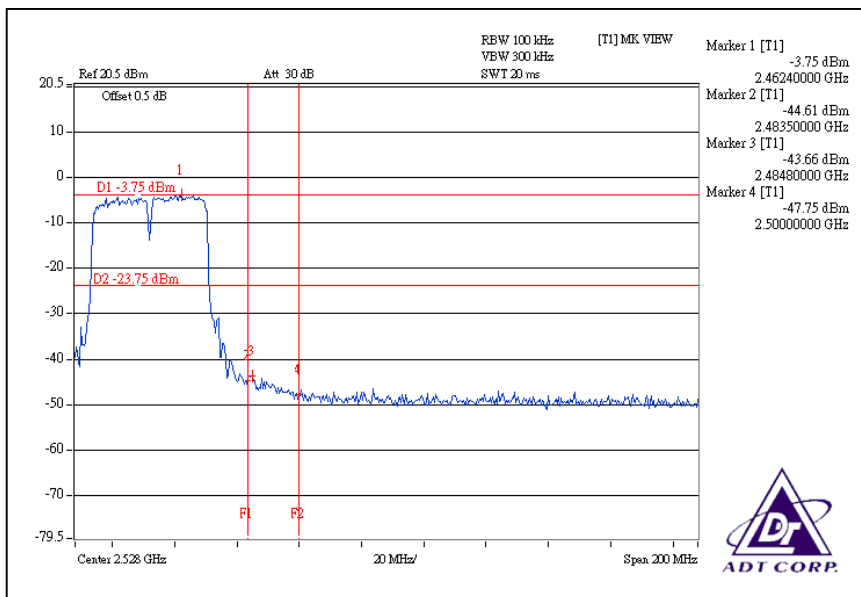

CH1

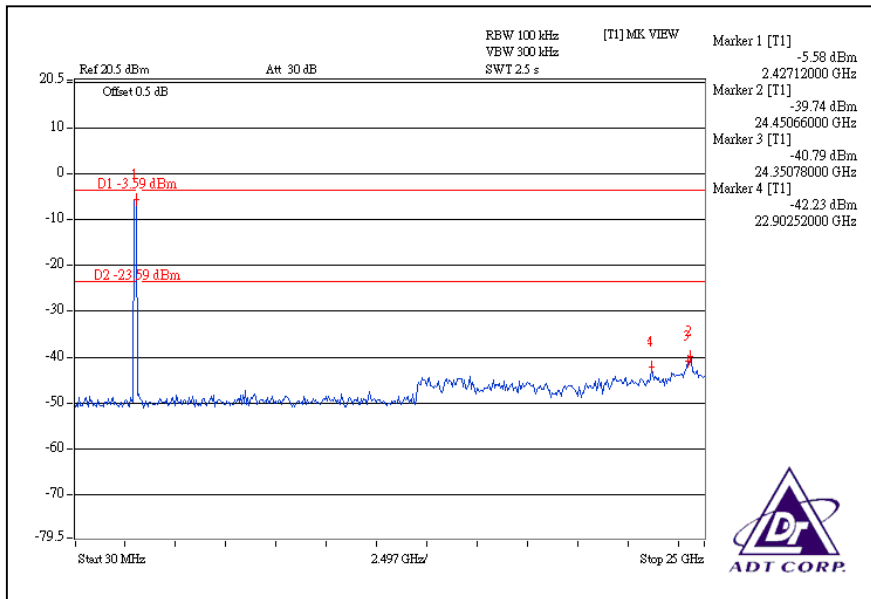

CH7

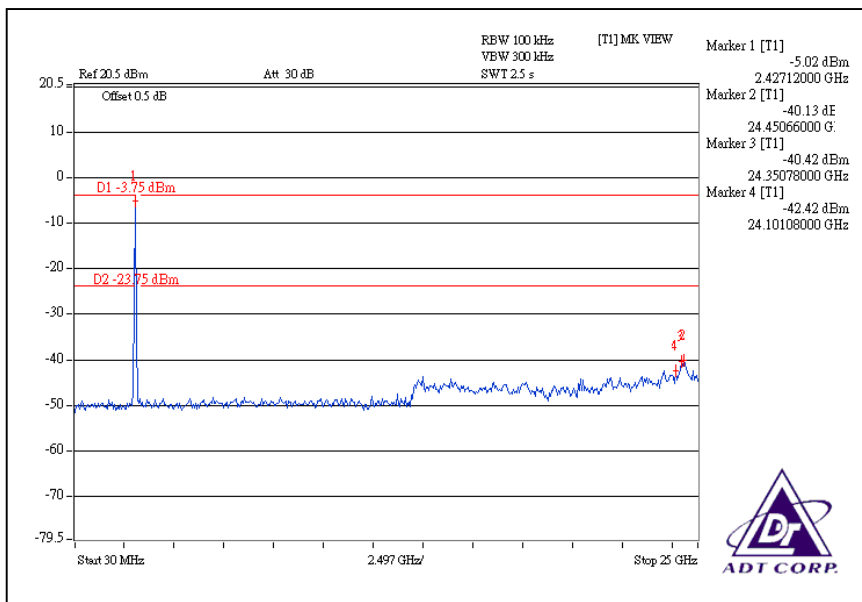

For Chain (1):CH1

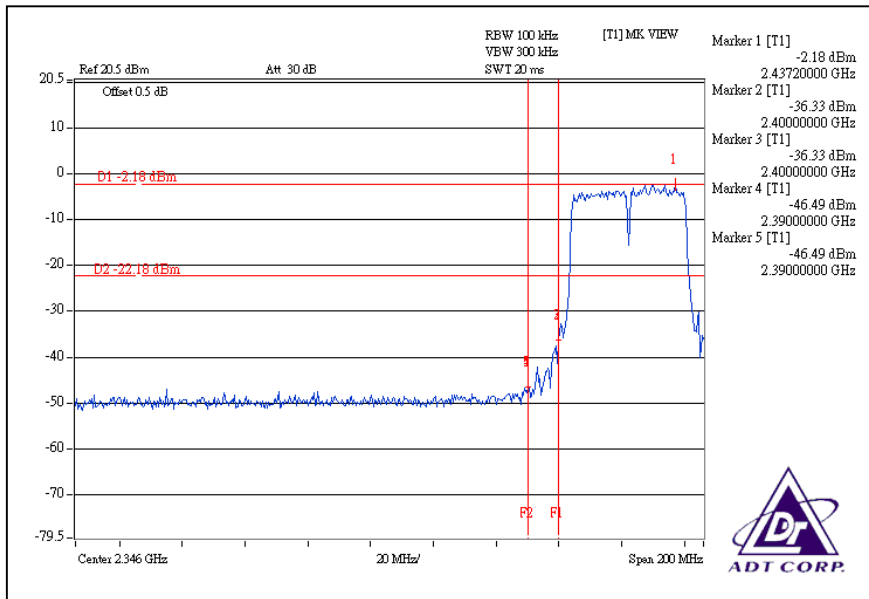

CH7

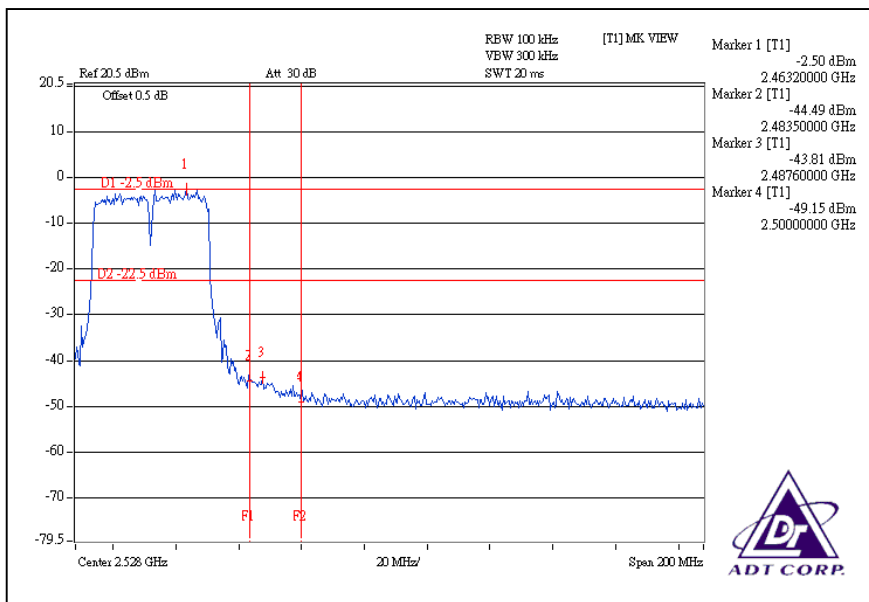

CH1

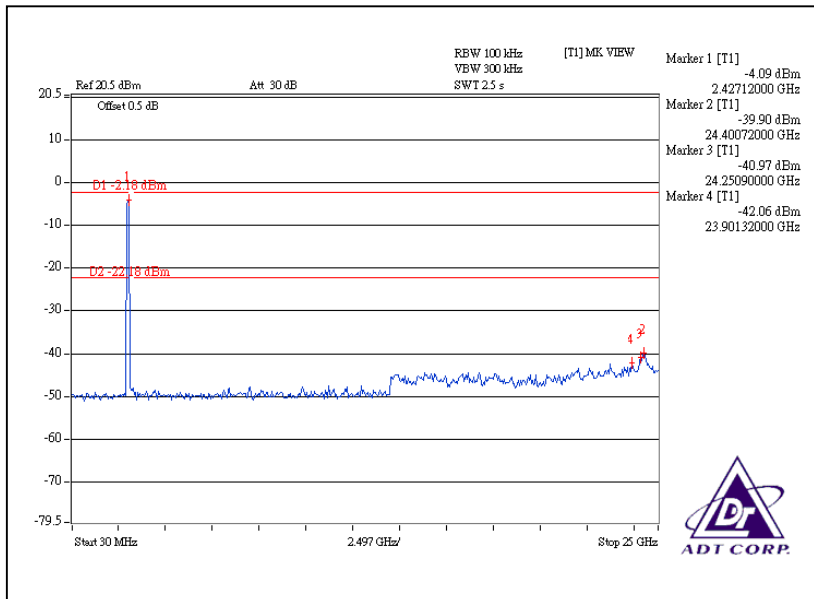

CH7

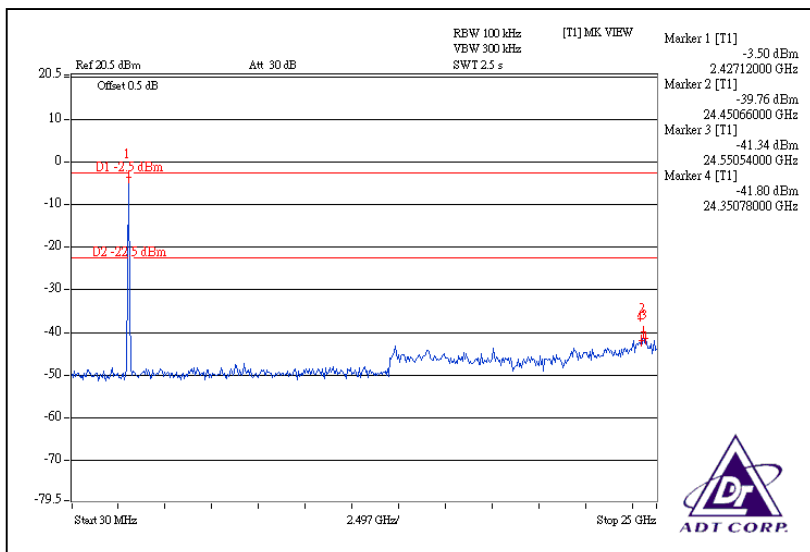

4.7 ANTENNA REQUIREMENT

4.7.1 STANDARD APPLICABLE

For intentional device, according to FCC 47 CFR Section 15.203, an intentional radiator shall be designed to ensure that no antenna other than that furnished by the responsible party shall be used with the device. And according to FCC 47 CFR Section 15.247 (b), if transmitting antennas of directional gain greater than 6dBi are used, the power shall be reduced by the amount in dB that the directional gain of the antenna exceeds 6dBi.

4.7.2 ANTENNA CONNECTED CONSTRUCTION

There are two antennas provided to this EUT, please refer to the following table:

No.	Antenna Type	Gain (dBi)	Antenna Connector
1	Dipole	2	NA
2	Dipole	2	NA



5. INFORMATION ON THE TESTING LABORATORIES

We, ADT Corp., were founded in 1988 to provide our best service in EMC, Radio, Telecom and Safety consultation. Our laboratories are accredited and approved by the following approval agencies according to ISO/IEC 17025.

USA	FCC, UL, A2LA
Germany	TUV Rheinland
Japan	VCCI
Norway	NEMKO
Canada	INDUSTRY CANADA , CSA
R.O.C.	TAF, BSMI, NCC
Netherlands	Telefication
Singapore	GOST-ASIA(MOU)
Russia	CERTIS(MOU)

Copies of accreditation certificates of our laboratories obtained from approval agencies can be downloaded from our web site:

www.adt.com.tw/index.5/phtml. If you have any comments, please feel free to contact us at the following:

Linko EMC/RF Lab:

Tel: 886-2-26052180

Fax: 886-2-26052943

Hsin Chu EMC/RF Lab:

Tel: 886-3-5935343

Fax: 886-3-5935342

Hwa Ya EMC/RF/Safety Telecom Lab:

Tel: 886-3-3183232

Fax: 886-3-3185050

Web Site: www.adt.com.tw

The address and road map of all our labs can be found in our web site also

6.APPENDIX-A- MODIFICATIONS RECORDERS FOR ENGINEERING CHANGES TO THE EUT BY THE LAB

No any modifications are made to the EUT by the lab during the test.