



FCC TEST REPORT

REPORT NO.: RF941025L06

MODEL NO.: F5D8630-4

RECEIVED: Nov. 09, 2005

TESTED: Nov. 15 ~ Nov. 22, 2005

ISSUED: Nov. 24, 2005

APPLICANT: Belkin Corporation

ADDRESS: 501 West Walnut Avenue Compton, CA 90220

ISSUED BY: Advance Data Technology Corporation

LAB ADDRESS: 47 14th Lin, Chiapau Tsun, Linko, Taipei,
Taiwan, R.O.C.

TEST LOCATION: No. 19, Hwa Ya 2nd Rd., Kueishan, Taoyuan,
Taiwan, R.O.C.

This test report consists of 104 pages in total. It may be duplicated completely for legal use with the approval of the applicant. It should not be reproduced except in full, without the written approval of our laboratory. The client should not use it to claim product endorsement by CNLA, A2LA or any government agencies. The test results in the report only apply to the tested sample.





TABLE OF CONTENTS

1.	CERTIFICATION	5
2.	SUMMARY OF TEST RESULTS	6
2.1	MEASUREMENT UNCERTAINTY	6
3.	GENERAL INFORMATION.....	7
3.1	GENERAL DESCRIPTION OF EUT	7
3.2	DESCRIPTION OF TEST MODES	8
3.2.1	CONFIGURATION OF SYSTEM UNDER TEST	8
3.2.2	TEST MODE APPLICABILITY AND TESTED CHANNEL DETAIL.....	9
3.3	GENERAL DESCRIPTION OF APPLIED STANDARDS	13
3.4	DESCRIPTION OF SUPPORT UNITS	13
4.	TEST TYPES AND RESULTS (FOR SINGLE CHAIN (TX))	14
4.1	CONDUCTED EMISSION MEASUREMENT	14
4.1.1	LIMITS OF CONDUCTED EMISSION MEASUREMENT	14
4.1.2	TEST INSTRUMENTS	14
4.1.3	TEST PROCEDURES.....	15
4.1.4	DEVIATION FROM TEST STANDARD	15
4.1.5	TEST SETUP	16
4.1.6	EUT OPERATING CONDITIONS.....	16
4.1.7	TEST RESULTS	17
4.2	RADIATED EMISSION MEASUREMENT	23
4.2.1	LIMITS OF RADIATED EMISSION MEASUREMENT	23
4.2.2	TEST INSTRUMENTS	24
4.2.3	TEST PROCEDURES.....	25
4.2.4	DEVIATION FROM TEST STANDARD	26
4.2.5	TEST SETUP	26
4.2.6	EUT OPERATING CONDITIONS.....	26
4.2.7	TEST RESULTS	27
4.3	6dB BANDWIDTH MEASUREMENT.....	34
4.3.1	LIMITS OF 6DB BANDWIDTH MEASUREMENT	34
4.3.2	TEST INSTRUMENTS	34
4.3.3	TEST PROCEDURE	35
4.3.4	DEVIATION FROM TEST STANDARD	35
4.3.5	TEST SETUP	35
4.3.6	EUT OPERATING CONDITIONS.....	35
4.3.7	TEST RESULTS	36
4.4	MAXIMUM PEAK OUTPUT POWER.....	42
4.4.1	LIMITS OF MAXIMUM PEAK OUTPUT POWER MEASUREMENT	42
4.4.2	TEST INSTRUMENTS.....	42
4.4.3	TEST PROCEDURES.....	43
4.4.4	DEVIATION FROM TEST STANDARD.....	43
4.4.5	TEST SETUP	43
4.4.6	EUT OPERATING CONDITIONS	43



4.4.7 TEST RESULTS..... 44

4.5 POWER SPECTRAL DENSITY MEASUREMENT 45

4.5.1 LIMITS OF POWER SPECTRAL DENSITY MEASUREMENT 45

4.5.2 TEST INSTRUMENTS 45

4.5.3 TEST PROCEDURE 46

4.5.4 DEVIATION FROM TEST STANDARD 46

4.5.5 TEST SETUP 46

4.5.6 EUT OPERATING CONDITIONS 46

4.5.7 TEST RESULTS 47

4.6 BAND EDGES MEASUREMENT 53

4.6.1 LIMITS OF BAND EDGES MEASUREMENT 53

4.6.2 TEST INSTRUMENTS 53

4.6.3 TEST PROCEDURE 53

4.6.4 DEVIATION FROM TEST STANDARD 53

4.6.5 EUT OPERATING CONDITION 53

4.6.6 TEST RESULTS 54

5. TEST TYPES AND RESULTS (FOR DUAL CHAIN (TX)) 62

5.1 CONDUCTED EMISSION MEASUREMENT 62

5.1.1 LIMITS OF CONDUCTED EMISSION MEASUREMENT 62

5.1.2 TEST INSTRUMENTS 62

5.1.3 TEST PROCEDURES 63

5.1.4 DEVIATION FROM TEST STANDARD 63

5.1.5 TEST SETUP 64

5.1.6 EUT OPERATING CONDITIONS 64

5.1.7 TEST RESULTS 65

5.2 RADIATED EMISSION MEASUREMENT 71

5.2.1 LIMITS OF RADIATED EMISSION MEASUREMENT 71

5.2.2 TEST INSTRUMENTS 72

5.2.3 TEST PROCEDURES 73

5.2.4 DEVIATION FROM TEST STANDARD 74

5.2.5 TEST SETUP 74

5.2.6 EUT OPERATING CONDITIONS 74

5.2.7 TEST RESULTS 75

5.3 6dB BANDWIDTH MEASUREMENT..... 79

5.3.1 LIMITS OF 6DB BANDWIDTH MEASUREMENT 79

5.3.2 TEST INSTRUMENTS 79

5.3.3 TEST PROCEDURE 80

5.3.4 DEVIATION FROM TEST STANDARD 80

5.3.5 TEST SETUP 80

5.3.6 EUT OPERATING CONDITIONS 80

5.3.7 TEST RESULTS 81

5.4 MAXIMUM PEAK OUTPUT POWER..... 85

5.4.1 LIMITS OF MAXIMUM PEAK OUTPUT POWER MEASUREMENT..... 85

5.4.2 TEST INSTRUMENTS 85

5.4.3 TEST PROCEDURES 86



5.4.4 DEVIATION FROM TEST STANDARD 86

5.4.5 TEST SETUP 86

5.4.6 EUT OPERATING CONDITIONS 86

5.4.7 TEST RESULTS 87

5.5 POWER SPECTRAL DENSITY MEASUREMENT 88

5.5.1 LIMITS OF POWER SPECTRAL DENSITY MEASUREMENT 88

5.5.2 TEST INSTRUMENTS 88

5.5.3 TEST PROCEDURE 89

5.5.4 DEVIATION FROM TEST STANDARD 89

5.5.5 TEST SETUP 89

5.5.6 EUT OPERATING CONDITIONS 89

5.5.7 TEST RESULTS 90

5.6 BAND EDGES MEASUREMENT 94

5.6.1 LIMITS OF BAND EDGES MEASUREMENT 94

5.6.2 TEST INSTRUMENTS 94

5.6.3 TEST PROCEDURE 95

5.6.4 DEVIATION FROM TEST STANDARD 95

5.6.5 EUT OPERATING CONDITION 95

5.6.6 TEST RESULTS 96

5.7 ANTENNA REQUIREMENT 100

5.7.1 STANDARD APPLICABLE 100

5.7.2 ANTENNA CONNECTED CONSTRUCTION 100

6. PHOTOGRAPHS OF THE TEST CONFIGURATION 101

7. INFORMATION ON THE TESTING LABORATORIES 103

APPENDIX-A A-1



1. CERTIFICATION

PRODUCT : ADSL Modem with Wireless Pre-N Router
MODEL NO.: F5D8630-4
BRAND: Belkin
APPLICANT : Belkin Corporation
TESTED: Nov. 15 ~ Nov. 22, 2005
TEST SAMPLE: ENGINEERING SAMPLE
STANDARDS : FCC Part 15, Subpart C (Section 15.247),
ANSI C63.4-2003

The above equipment has been tested by **Advance Data Technology Corporation**, and found compliance with the requirement of the above standards. The test record, data evaluation & Equipment Under Test (EUT) configurations represented herein are true and accurate accounts of the measurements of the sample's EMC characteristics under the conditions specified in this report.

PREPARED BY : Andrea Hsia, **DATE:** Nov. 24, 2005
Andrea Hsia

TECHNICAL
ACCEPTANCE : Gary Chang, **DATE:** Nov. 24, 2005
Responsible for RF Gary Chang

APPROVED BY : Cody Chang, **DATE:** Nov. 24, 2005
Cody Chang / Deputy Manager



2. SUMMARY OF TEST RESULTS

The EUT has been tested according to the following specifications:

APPLIED STANDARD: FCC Part 15, Subpart C			
STANDARD SECTION	TEST TYPE AND LIMIT	RESULT	REMARK
15.207	AC Power Conducted Emission	PASS	Meet the requirement of limit. Minimum passing margin is -10.48dB at 1.332MHz.
15.247(a)(2)	Spectrum Bandwidth of a Direct Sequence Spread Spectrum System Limit : min. 500kHz	PASS	Meet the requirement of limit.
15.247(b)	Maximum Peak Output Power Limit: max. 30dBm	PASS	Meet the requirement of limit.
15.247(d)	Transmitter Radiated Emissions Limit: Table 15.209	PASS	Meet the requirement of limit. Minimum passing margin is -1.23dB at 30.00MHz.
15.247(e)	Power Spectral Density Limit: max. 8dBm	PASS	Meet the requirement of limit.
15.247(d)	Band Edge Measurement Limit: 20 dB less than the peak value of fundamental frequency	PASS	Meet the requirement of limit.

2.1 MEASUREMENT UNCERTAINTY

Where relevant, the following measurement uncertainty levels have been estimated for tests performed on the EUT as specified in CISPR 16-4:

MEASUREMENT	FREQUENCY	UNCERTAINTY
Conducted emissions	9kHz ~ 30MHz	2.44 dB
Radiated emissions	30MHz ~ 200MHz	3.73 dB
	200MHz ~ 1000MHz	3.74 dB
	1GHz ~ 18GHz	2.20 dB
	18GHz ~ 40GHz	1.88 dB

This uncertainty represents an expanded uncertainty expressed at approximately the 95% confidence level using a coverage factor of k=2.



3. GENERAL INFORMATION

3.1 GENERAL DESCRIPTION OF EUT

PRODUCT	ADSL Modem with Wireless Pre-N Router
MODEL NO.	F5D8630-4
POWER SUPPLY	15.0Vdc from AC Adapter
MODULATION TYPE	CCK, QPSK, BPSK for SSS 64QAM, 16QAM, QPSK, BPSK for OFDM
MODULATION TECHNOLOGY	DSSS, OFDM
TRANSFER RATE	802.11b: 11/5.5/2/1Mbps 802.11g: 54/48/36/24/18/12/9/6Mbps (MIMO OFDM: 54/48/36Mbps *see NOTE 8)
FREQUENCY RANGE	2412MHz ~ 2462MHz
NUMBER OF CHANNEL	11 for Normal mode
MAXIMUM OUTPUT POWER (SINGAL CHAIN)	65.013mW
MAXIMUM OUTPUT POWER (DUAL CHAIN)	63.324mW
ANTENNA TYPE	Dipole antenna with 2dBi gain
DATA CABLE	NA
I/O PORTS	NA
ASSOCIATED DEVICES	NA

NOTE:

- The EUT was tested with the following adapters:

BRAND:	LEI
MODEL:	MU15-150100-A1
INPUT:	100-240Vac, 50/60Hz , 0.5A
OUTPUT:	15Vdc, 1.0A
POWER LINE:	DC 1.8m non-shielded cable without core

- The EUT is 2x3 spatial MIMO (2 Tx & 3 Rx) without beam-forming function.
- The EUT can operate in a single chain configuration (either chain 0 or 1 transmit only) or dual chain configuration (both chain 0 and chain 1 transmit simultaneously).
- When the EUT is in the 802.11b mode, it is always in the single chain configuration.
- When the EUT is operating in the 802.11g mode, it can operate in either sigle or dual chains configuration. Switching between the single and dual chain configurations is accomplished electronically, with no hardware changes required.
- The EUT complies with IEEE 802.11g standards and backwards compatible with IEEE 802.11b products.
- The EUT operates in the 2.4GHz frequency spectrum with throughput of up to 54Mbps.
- The max. transfer rate in sigle chain is 54Mbps, and could achieve up to 108Mbps in dual chains operation mode.
- The above EUT information was declared by manufacturer and for more detailed features description, please refer to the manufacturer's specifications or User's Manual.

3.2 DESCRIPTION OF TEST MODES

For 802.11b/g: Eleven channels are provided to this EUT for normal mode.

CHANNEL	FREQUENCY	CHANNEL	FREQUENCY
1	2412 MHz	7	2442 MHz
2	2417 MHz	8	2447 MHz
3	2422 MHz	9	2452 MHz
4	2427 MHz	10	2457 MHz
5	2432 MHz	11	2462 MHz
6	2437 MHz		

3.2.1 CONFIGURATION OF SYSTEM UNDER TEST

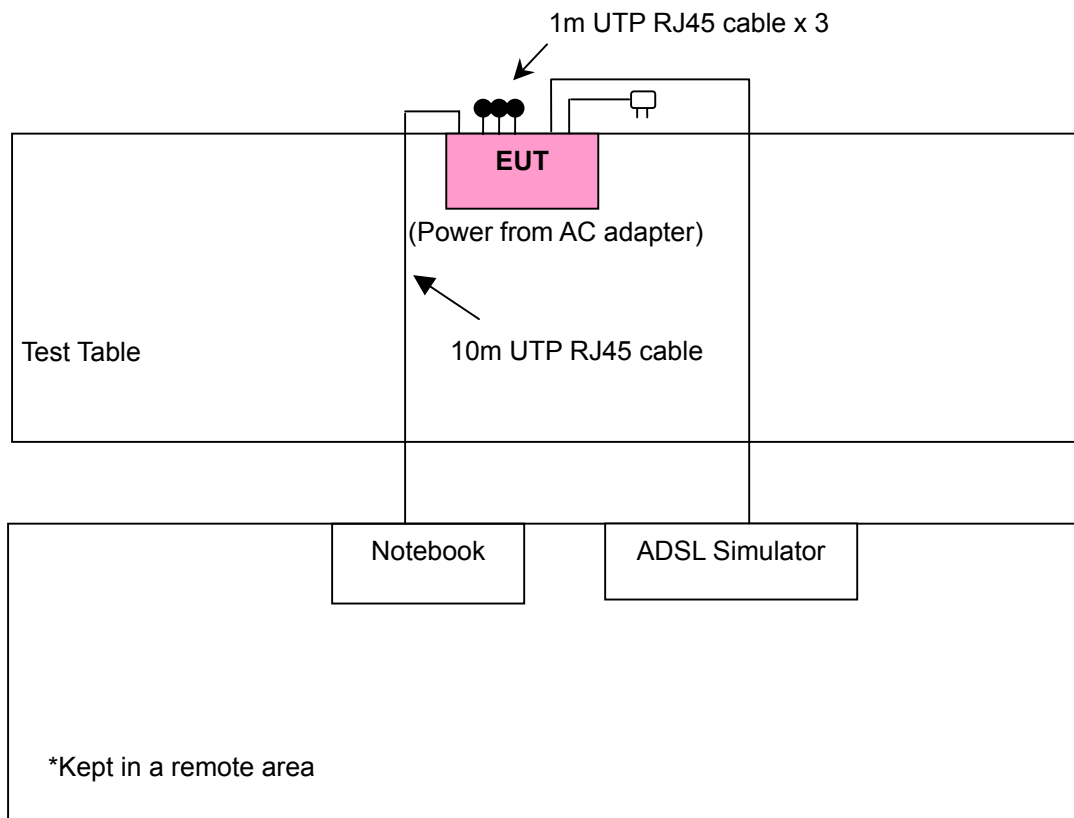



3.2.2 TEST MODE APPLICABILITY AND TESTED CHANNEL DETAIL

FOR SINGLE CHAIN (TX):

APPLICABLE TO				DESCRIPTION
PLC	RE<1G	RE≥1G	APCM	
v	v	v	v	NA

Where **PLC**: Power Line Conducted Emission
RE≥1G: Radiated Emission above 1GHz

RE<1G RE: Radiated Emission below 1GHz
APCM: Antenna Port Conducted Measurement

POWER LINE CONDUCTED EMISSION TEST:

- Pre-Scan has been conducted to determine the worst-case mode from all possible combinations between available modulations, data rates and antenna ports (if EUT with antenna diversity architecture).
- Following channel(s) was (were) selected for the final test as listed below.

MODE	AVAILABLE CHANNEL	TESTED CHANNEL	MODULATION TECHNOLOGY	MODULATION TYPE	DATA RATE (Mbps)
802.11g	1 to 11	1, 6, 11	OFDM	BPSK	6

RADIATED EMISSION TEST (BELOW 1 GHz):

- Pre-Scan has been conducted to determine the worst-case mode from all possible combinations between available modulations, data rates and antenna ports (if EUT with antenna diversity architecture).
- Following channel(s) was (were) selected for the final test as listed below.

MODE	AVAILABLE CHANNEL	TESTED CHANNEL	MODULATION TECHNOLOGY	MODULATION TYPE	DATA RATE (Mbps)
802.11b	1 to 11	11	DSSS	BPSK	1
802.11g	1 to 11	11	OFDM	BPSK	6



RADIATED EMISSION TEST (ABOVE 1 GHz):

- Pre-Scan has been conducted to determine the worst-case mode from all possible combinations between available modulations, data rates and antenna ports (if EUT with antenna diversity architecture).
- Following channel(s) was (were) selected for the final test as listed below.

MODE	AVAILABLE CHANNEL	TESTED CHANNEL	MODULATION TECHNOLOGY	MODULATION TYPE	DATA RATE (Mbps)
802.11b	1 to 11	1, 6, 11	DSSS	BPSK	1
802.11g	1 to 11	1, 6, 11	OFDM	BPSK	6

BANDEDGE MEASUREMENT:

- Pre-Scan has been conducted to determine the worst-case mode from all possible combinations between available modulations, data rates and antenna ports (if EUT with antenna diversity architecture).
- Following channel(s) was (were) selected for the final test as listed below.

MODE	AVAILABLE CHANNEL	TESTED CHANNEL	MODULATION TECHNOLOGY	MODULATION TYPE	DATA RATE (Mbps)
802.11b	1 to 11	1, 11	DSSS	BPSK	1
802.11g	1 to 11	1, 11	OFDM	BPSK	6

ANTENNA PORT CONDUCTED MEASUREMENT:

- Pre-Scan has been conducted to determine the worst-case mode from all possible combinations between available modulations, data rates and antenna ports (if EUT with antenna diversity architecture).
- Following channel(s) was (were) selected for the final test as listed below.

MODE	AVAILABLE CHANNEL	TESTED CHANNEL	MODULATION TECHNOLOGY	MODULATION TYPE	DATA RATE (Mbps)
802.11b	1 to 11	1, 6, 11	DSSS	BPSK	1
802.11g	1 to 11	1, 6, 11	OFDM	BPSK	6



FOR DUAL CHAIN (TX):

APPLICABLE TO				DESCRIPTION
PLC	RE<1G	RE≥1G	APCM	
v	v	v	v	NA

Where **PLC:** Power Line Conducted Emission **RE<1G RE:** Radiated Emission below 1GHz
RE≥1G: Radiated Emission above 1GHz **APCM:** Antenna Port Conducted Measurement

POWER LINE CONDUCTED EMISSION TEST:

- Pre-Scan has been conducted to determine the worst-case mode from all possible combinations between available modulations, data rates and antenna ports (if EUT with antenna diversity architecture).
- Following channel(s) was (were) selected for the final test as listed below.

MODE	AVAILABLE CHANNEL	TESTED CHANNEL	MODULATION TECHNOLOGY	MODULATION TYPE	DATA RATE (Mbps)
802.11g	1 to 11	1, 6, 11	OFDM	16QAM	36

RADIATED EMISSION TEST (BELOW 1 GHz):

- Pre-Scan has been conducted to determine the worst-case mode from all possible combinations between available modulations, data rates and antenna ports (if EUT with antenna diversity architecture).
- Following channel(s) was (were) selected for the final test as listed below.

MODE	AVAILABLE CHANNEL	TESTED CHANNEL	MODULATION TECHNOLOGY	MODULATION TYPE	DATA RATE (Mbps)
802.11g	1 to 11	11	OFDM	16QAM	36

RADIATED EMISSION TEST (ABOVE 1 GHz):

- Pre-Scan has been conducted to determine the worst-case mode from all possible combinations between available modulations, data rates and antenna ports (if EUT with antenna diversity architecture).
- Following channel(s) was (were) selected for the final test as listed below.

MODE	AVAILABLE CHANNEL	TESTED CHANNEL	MODULATION TECHNOLOGY	MODULATION TYPE	DATA RATE (Mbps)
802.11g	1 to 11	11	OFDM	16QAM	36



BANDEDGE MEASUREMENT:

- Pre-Scan has been conducted to determine the worst-case mode from all possible combinations between available modulations, data rates and antenna ports (if EUT with antenna diversity architecture).
- Following channel(s) was (were) selected for the final test as listed below.

MODE	AVAILABLE CHANNEL	TESTED CHANNEL	MODULATION TECHNOLOGY	MODULATION TYPE	DATA RATE (Mbps)
802.11g	1 to 11	1, 11	OFDM	16QAM	36

ANTENNA PORT CONDUCTED MEASUREMENT:

- Pre-Scan has been conducted to determine the worst-case mode from all possible combinations between available modulations, data rates and antenna ports (if EUT with antenna diversity architecture).
- Following channel(s) was (were) selected for the final test as listed below.

MODE	AVAILABLE CHANNEL	TESTED CHANNEL	MODULATION TECHNOLOGY	MODULATION TYPE	DATA RATE (Mbps)
802.11g	1 to 11	1, 6, 11	OFDM	16QAM	36



3.3 GENERAL DESCRIPTION OF APPLIED STANDARDS

The EUT is a RF Product. According to the specifications of the manufacturer, it must comply with the requirements of the following standards:

FCC Part 15, Subpart C. (15.247)

ANSI C63.4-2003

All test items have been performed and recorded as per the above standards.

NOTE: The EUT is also considered as a kind of computer peripheral, because the connection to computer is necessary for typical use. It has been verified to comply with the requirements of FCC Part 15, Subpart B, Class B (DoC). The test report has been issued separately.

3.4 DESCRIPTION OF SUPPORT UNITS

The EUT has been tested as an independent unit together with other necessary accessories or support units. The following support units or accessories were used to form a representative test configuration during the tests.

NO.	PRODUCT	BRAND	MODEL NO.	SERIAL NO.	FCC ID
1	NOTEBOOK COMPUTER	DELL	PP05L	12130898320	E2K24CLNS
2	ADSL SIMULATOR	TI	AC5	B089192	NA

NO.	SIGNAL CABLE DESCRIPTION OF THE ABOVE SUPPORT UNITS
1	NA
2	NA

NOTE: All power cords of the above support units are non shielded (1.8m).



4. TEST TYPES AND RESULTS (FOR SINGLE CHAIN (TX))

4.1 CONDUCTED EMISSION MEASUREMENT

4.1.1 LIMITS OF CONDUCTED EMISSION MEASUREMENT

FREQUENCY OF EMISSION (MHz)	CONDUCTED LIMIT (dB μ V)	
	Quasi-peak	Average
0.15 ~ 0.5	66 to 56	56 to 46
0.5 ~ 5	56	46
5 ~ 30	60	50

- NOTE:**
1. The lower limit shall apply at the transition frequencies.
 2. The limit decreases in line with the logarithm of the frequency in the range of 0.15 to 0.50 MHz.
 3. All emanations from a class A/B digital device or system, including any network of conductors and apparatus connected thereto, shall not exceed the level of field strengths specified above.

4.1.2 TEST INSTRUMENTS

DESCRIPTION & MANUFACTURER	MODEL NO.	SERIAL NO.	CALIBRATED UNTIL
Test Receiver ROHDE & SCHWARZ	ESCS30	100288	Nov. 02, 2006
RF signal cable Woken	5D-FB	Cable-HyC02-01	Jan. 09, 2006
LISN ROHDE & SCHWARZ	ESH2-Z5	100100	Jan. 20, 2006
LISN ROHDE & SCHWARZ	ESH3-Z5	100311	Jan. 20, 2006
Software ADT	ADT_Cond_V3	NA	NA

- NOTE:**
1. The calibration interval of the above test instruments is 12 months and the calibrations are traceable to NML/ROC and NIST/USA.
 2. The test was performed in HwaYa Shielded Room 3.
 3. The VCCI Site Registration No. is C-2047.



4.1.3 TEST PROCEDURES

- a. The EUT was placed 0.4 meters from the conducting wall of the shielded room with EUT being connected to the power mains through a line impedance stabilization network (LISN). Other support units were connected to the power mains through another LISN. The two LISNs provide 50 ohm/ 50uH of coupling impedance for the measuring instrument.
- b. Both lines of the power mains connected to the EUT were checked for maximum conducted interference.
- c. The frequency range from 150kHz to 30MHz was searched. Emission levels under Limit - 20dB was not recorded.

4.1.4 DEVIATION FROM TEST STANDARD

No deviation

4.1.5 TEST SETUP

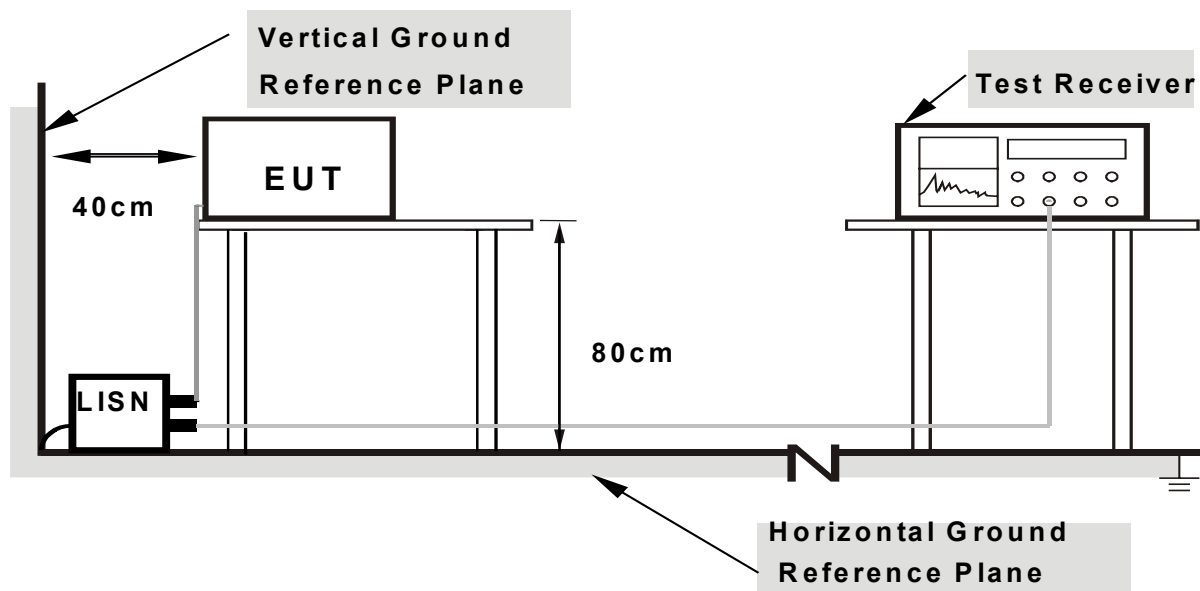

- Note:**
- 1.Support units were connected to second LISN.
 - 2.Both of LISNs (AMN) are 80 cm from EUT and at least 80 from other units and other metal planes

For the actual test configuration, please refer to the related item – Photographs of the Test Configuration.

4.1.6 EUT OPERATING CONDITIONS

- a. Connected the EUT to a notebook system via RJ45 cable and placed on a testing table.
- b. The notebook system ran a test program (provided by manufacturer) to enable EUT under transmission/receiving condition continuously at specific channel frequency.
- c. Steps a ~ b were repeated.



4.1.7 TEST RESULTS

CONDUCTED WORST CASE DATA

EUT	ADSL Modem with Wireless Pre-N Router	MEASUREMENT DETAIL	
MODEL	F5D8630-4	PHASE	Line 1
CHANNEL	Channel 1	6dB BANDWIDTH	9 kHz
MODULATION TYPE	BPSK	ENVIRONMENTAL CONDITIONS	25deg. C, 65%RH, 991hPa
TRANSFER RATE	6Mbps	INPUT POWER (SYSTEM)	120Vac, 60 Hz
TESTED BY	Jay Hsu		

No	Freq. [MHz]	Corr. Factor (dB)	Reading Value		Emission Level		Limit		Margin	
			[dB (uV)]		[dB (uV)]		[dB (uV)]		(dB)	
			Q.P.	AV.	Q.P.	AV.	Q.P.	AV.	Q.P.	AV.
1	0.173	0.11	35.18	-	35.29	-	64.79	54.79	-29.51	-
2	0.982	0.23	38.27	-	38.50	-	56.00	46.00	-17.50	-
3	1.336	0.24	44.82	-	45.06	-	56.00	46.00	-10.94	-
4	2.324	0.26	38.58	-	38.84	-	56.00	46.00	-17.16	-
5	3.918	0.29	42.50	-	42.79	-	56.00	46.00	-13.21	-
6	18.242	0.83	34.92	-	35.75	-	60.00	50.00	-24.25	-

- REMARKS:**
1. Q.P. and AV. are abbreviations of quasi-peak and average individually.
 2. "-": The Quasi-peak reading value also meets average limit and measurement with the average detector is unnecessary.
 3. The emission levels of other frequencies were very low against the limit.
 4. Margin value = Emission level - Limit value
 5. Correction factor = Insertion loss + Cable loss
 6. Emission Level = Correction Factor + Reading Value.

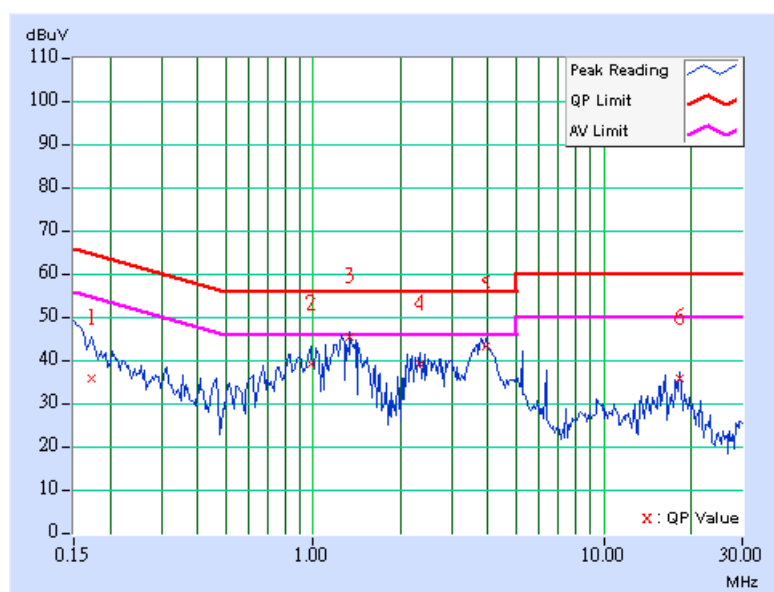



EUT	ADSL Modem with Wireless Pre-N Router	MEASUREMENT DETAIL	
MODEL	F5D8630-4	PHASE	Line 2
CHANNEL	Channel 1	6dB BANDWIDTH	9 kHz
MODULATION TYPE	BPSK	ENVIRONMENTAL CONDITIONS	25deg. C, 65%RH, 991hPa
TRANSFER RATE	6Mbps	INPUT POWER (SYSTEM)	120Vac, 60 Hz
TESTED BY	Jay Hsu		

No	Freq. [MHz]	Corr. Factor (dB)	Reading Value		Emission Level		Limit		Margin	
			[dB (uV)]		[dB (uV)]		[dB (uV)]		(dB)	
			Q.P.	AV.	Q.P.	AV.	Q.P.	AV.	Q.P.	AV.
1	0.154	0.11	39.92	-	40.03	-	65.80	55.80	-25.77	-
2	0.670	0.17	37.36	-	37.53	-	56.00	46.00	-18.47	-
3	0.826	0.20	40.02	-	40.22	-	56.00	46.00	-15.78	-
4	1.111	0.23	40.14	-	40.37	-	56.00	46.00	-15.63	-
5	3.910	0.29	43.39	-	43.68	-	56.00	46.00	-12.32	-
6	17.694	0.83	35.04	-	35.87	-	60.00	50.00	-24.13	-

- REMARKS:**
1. Q.P. and AV. are abbreviations of quasi-peak and average individually.
 2. "-": The Quasi-peak reading value also meets average limit and measurement with the average detector is unnecessary.
 3. The emission levels of other frequencies were very low against the limit.
 4. Margin value = Emission level - Limit value
 5. Correction factor = Insertion loss + Cable loss
 6. Emission Level = Correction Factor + Reading Value.

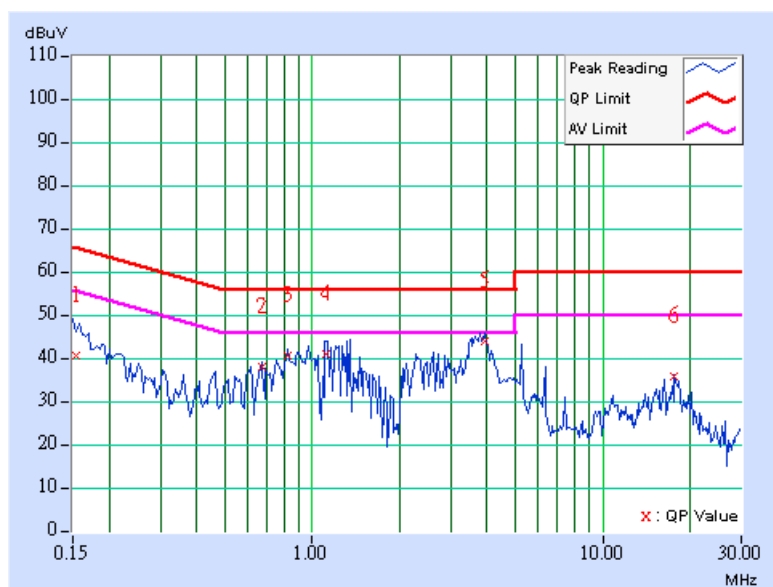



EUT	ADSL Modem with Wireless Pre-N Router	MEASUREMENT DETAIL	
MODEL	F5D8630-4	PHASE	Line 1
CHANNEL	Channel 6	6dB BANDWIDTH	9 kHz
MODULATION TYPE	BPSK	ENVIRONMENTAL CONDITIONS	25deg. C, 65%RH, 991hPa
TRANSFER RATE	6Mbps	INPUT POWER (SYSTEM)	120Vac, 60 Hz
TESTED BY	Jay Hsu		

No	Freq. [MHz]	Corr. Factor (dB)	Reading Value [dB (uV)]		Emission Level [dB (uV)]		Limit [dB (uV)]		Margin (dB)	
			Q.P.	AV.	Q.P.	AV.	Q.P.	AV.	Q.P.	AV.
			1	0.213	0.11	32.00	-	32.11	-	63.11
2	0.826	0.20	39.57	-	39.77	-	56.00	46.00	-16.23	-
3	1.188	0.23	44.55	-	44.78	-	56.00	46.00	-11.22	-
4	1.414	0.24	43.34	-	43.58	-	56.00	46.00	-12.42	-
5	3.914	0.29	42.52	-	42.81	-	56.00	46.00	-13.19	-
6	17.692	0.78	34.96	-	35.74	-	60.00	50.00	-24.26	-

- REMARKS:**
1. Q.P. and AV. are abbreviations of quasi-peak and average individually.
 2. "-": The Quasi-peak reading value also meets average limit and measurement with the average detector is unnecessary.
 3. The emission levels of other frequencies were very low against the limit.
 4. Margin value = Emission level - Limit value
 5. Correction factor = Insertion loss + Cable loss
 6. Emission Level = Correction Factor + Reading Value.

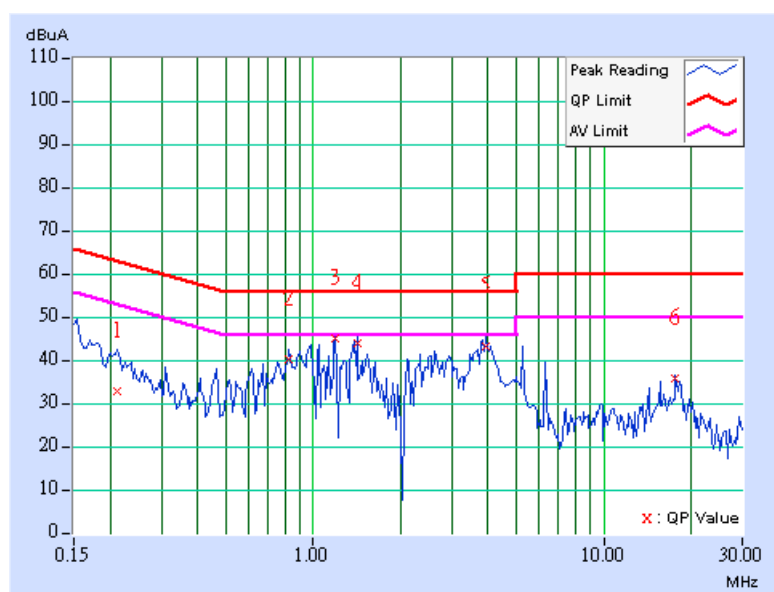



EUT	ADSL Modem with Wireless Pre-N Router	MEASUREMENT DETAIL	
MODEL	F5D8630-4	PHASE	Line 2
CHANNEL	Channel 6	6dB BANDWIDTH	9 kHz
MODULATION TYPE	BPSK	ENVIRONMENTAL CONDITIONS	25deg. C, 65%RH, 991hPa
TRANSFER RATE	6Mbps	INPUT POWER (SYSTEM)	120Vac, 60 Hz
TESTED BY	Jay Hsu		

No	Freq. [MHz]	Corr. Factor (dB)	Reading Value [dB (uV)]		Emission Level [dB (uV)]		Limit [dB (uV)]		Margin (dB)	
			Q.P.	AV.	Q.P.	AV.	Q.P.	AV.	Q.P.	AV.
			1	0.141	0.10	9.97	-	10.07	-	66.00
2	0.828	0.20	40.52	-	40.72	-	56.00	46.00	-15.28	-
3	1.332	0.24	44.38	-	44.62	-	56.00	46.00	-11.38	-
4	2.480	0.26	39.27	-	39.53	-	56.00	46.00	-16.47	-
5	3.852	0.29	42.79	-	43.08	-	56.00	46.00	-12.92	-
6	17.693	0.83	35.20	-	36.03	-	60.00	50.00	-23.97	-

- REMARKS:**
1. Q.P. and AV. are abbreviations of quasi-peak and average individually.
 2. "-": The Quasi-peak reading value also meets average limit and measurement with the average detector is unnecessary.
 3. The emission levels of other frequencies were very low against the limit.
 4. Margin value = Emission level - Limit value
 5. Correction factor = Insertion loss + Cable loss
 6. Emission Level = Correction Factor + Reading Value.

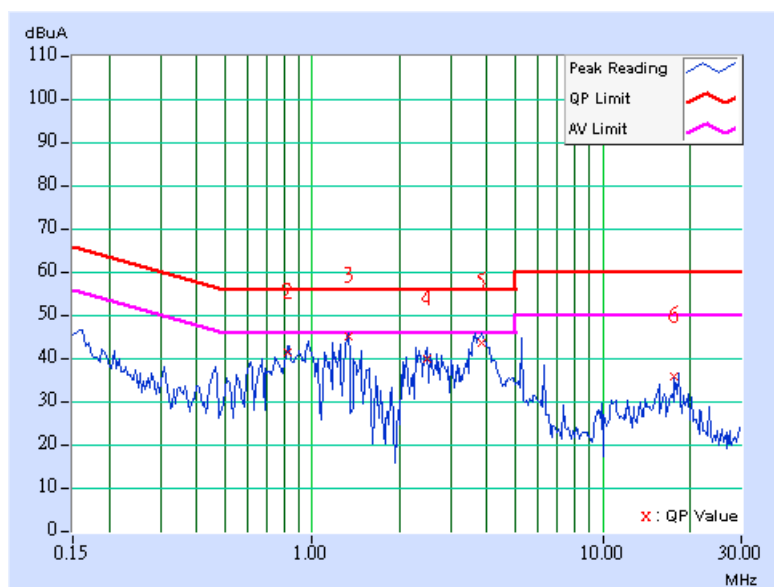



EUT	ADSL Modem with Wireless Pre-N Router	MEASUREMENT DETAIL	
MODEL	F5D8630-4	PHASE	Line 1
CHANNEL	Channel 11	6dB BANDWIDTH	9 kHz
MODULATION TYPE	BPSK	ENVIRONMENTAL CONDITIONS	25deg. C, 65%RH, 991hPa
TRANSFER RATE	6Mbps	INPUT POWER (SYSTEM)	120Vac, 60 Hz
TESTED BY	Jay Hsu		

No	Freq. [MHz]	Corr. Factor (dB)	Reading Value		Emission Level		Limit		Margin	
			[dB (uV)]		[dB (uV)]		[dB (uV)]		(dB)	
			Q.P.	AV.	Q.P.	AV.	Q.P.	AV.	Q.P.	AV.
1	0.154	0.11	39.68	-	39.79	-	65.79	55.79	-26.00	-
2	0.466	0.13	34.74	-	34.87	-	56.59	46.59	-21.72	-
3	0.974	0.23	40.80	-	41.03	-	56.00	46.00	-14.97	-
4	1.414	0.24	42.56	-	42.80	-	56.00	46.00	-13.20	-
5	3.914	0.29	42.54	-	42.83	-	56.00	46.00	-13.17	-
6	18.243	0.83	34.68	-	35.51	-	60.00	50.00	-24.49	-

- REMARKS:**
1. Q.P. and AV. are abbreviations of quasi-peak and average individually.
 2. "-": The Quasi-peak reading value also meets average limit and measurement with the average detector is unnecessary.
 3. The emission levels of other frequencies were very low against the limit.
 4. Margin value = Emission level - Limit value
 5. Correction factor = Insertion loss + Cable loss
 6. Emission Level = Correction Factor + Reading Value.

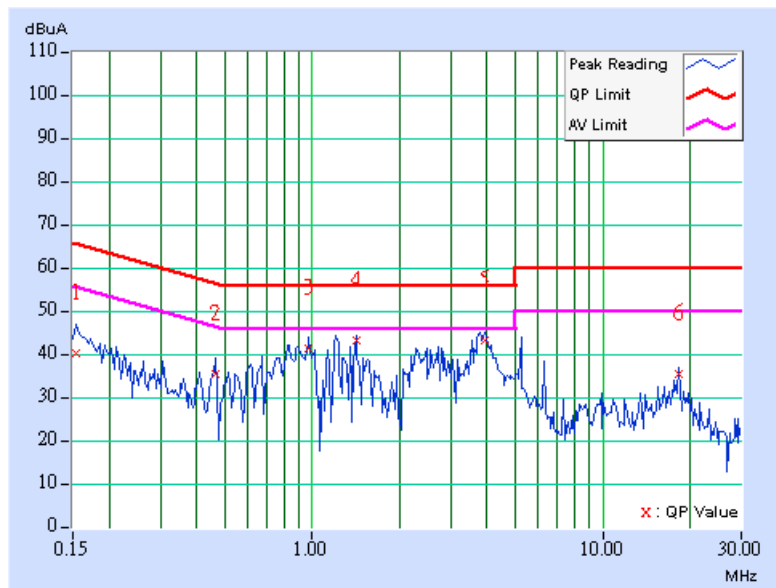



EUT	ADSL Modem with Wireless Pre-N Router	MEASUREMENT DETAIL	
MODEL	F5D8630-4	PHASE	Line 2
CHANNEL	Channel 11	6dB BANDWIDTH	9 kHz
MODULATION TYPE	BPSK	ENVIRONMENTAL CONDITIONS	25deg. C, 65%RH, 991hPa
TRANSFER RATE	6Mbps	INPUT POWER (SYSTEM)	120Vac, 60 Hz
TESTED BY	Jay Hsu		

No	Freq. [MHz]	Corr. Factor (dB)	Reading Value [dB (uV)]		Emission Level [dB (uV)]		Limit [dB (uV)]		Margin (dB)	
			Q.P.	AV.	Q.P.	AV.	Q.P.	AV.	Q.P.	AV.
			1	0.162	0.11	36.31	-	36.42	-	65.38
2	0.830	0.20	39.84	-	40.04	-	56.00	46.00	-15.96	-
3	1.332	0.24	44.26	-	44.50	-	56.00	46.00	-11.50	-
4	2.406	0.26	39.17	-	39.43	-	56.00	46.00	-16.57	-
5	3.758	0.29	43.48	-	43.77	-	56.00	46.00	-12.23	-
6	18.242	0.86	34.98	-	35.84	-	60.00	50.00	-24.16	-

- REMARKS:**
1. Q.P. and AV. are abbreviations of quasi-peak and average individually.
 2. "-": The Quasi-peak reading value also meets average limit and measurement with the average detector is unnecessary.
 3. The emission levels of other frequencies were very low against the limit.
 4. Margin value = Emission level - Limit value
 5. Correction factor = Insertion loss + Cable loss
 6. Emission Level = Correction Factor + Reading Value.

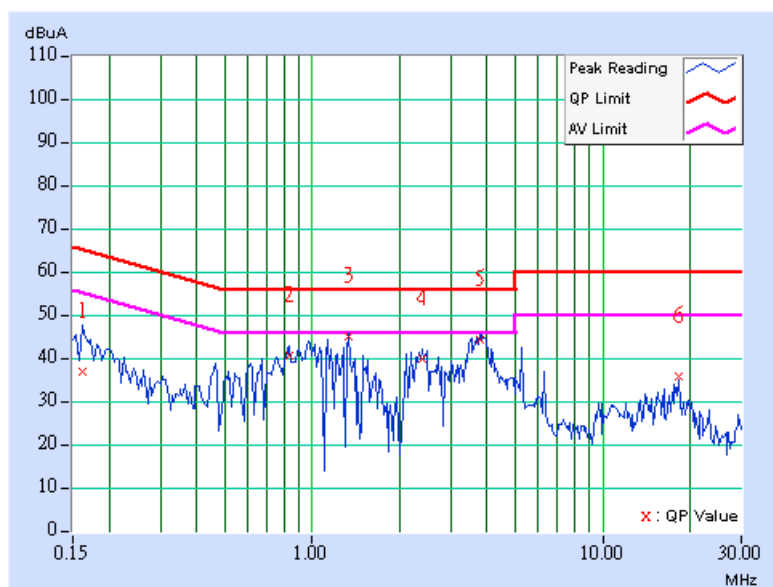



4.2 RADIATED EMISSION MEASUREMENT

4.2.1 LIMITS OF RADIATED EMISSION MEASUREMENT

Emissions radiated outside of the specified bands, shall be according to the general radiated limits in 15.209 as following:

FREQUENCIES (MHz)	FIELD STRENGTH (microvolts/meter)	MEASUREMENT DISTANCE (meters)
0.009-0.490	2400/F(kHz)	300
0.490-1.705	24000/F(kHz)	30
1.705-30.0	30	30
30-88	100	3
88-216	150	3
216-960	200	3
Above 960	500	3

NOTE:

1. The lower limit shall apply at the transition frequencies.
2. Emission level (dBuV/m) = 20 log Emission level (uV/m).
3. As shown in 15.35(b), for frequencies above 1000MHz, the field strength limits are based on average detector, however, the peak field strength of any emission shall not exceed the maximum permitted average limits, specified above by more than 20dB under any condition of modulation.



4.2.2 TEST INSTRUMENTS

DESCRIPTION & MANUFACTURER	MODEL NO.	SERIAL NO.	CALIBRATED UNTIL
Test Receiver ROHDE & SCHWARZ	ESI7	838496/016	Jan. 07, 2006
Spectrum Analyzer ROHDE & SCHWARZ	FSP40	100041	Nov. 29, 2005
BILOG Antenna SCHWARZBECK	VULB9168	9168-155	Jan. 22, 2006
HORN Antenna SCHWARZBECK	BBHA 9120D	9120D-404	Jan. 05, 2006
HORN Antenna SCHWARZBECK	BBHA 9170	BBHA 9170242	Jan. 23, 2006
Preamplifier Agilent	8449B	3008A01960	Nov. 09, 2006
RF signal cable HUBER+SUHNNER	SUCOFLEX 104	219272/4	Jan. 26, 2006
RF signal cable HUBER+SUHNNER	SUCOFLEX 104	219275/4	Jan. 26, 2006
Software ADT.	ADT_Radiated_V5.14	NA	NA
Antenna Tower inn-co GmbH	MA 4000	010303	NA
Antenna Tower Controller inn-co GmbH	CO2000	019303	NA
Turn Table ADT.	TT100.	TT93021704	NA
Turn Table Controller ADT.	SC100.	SC93021704	NA

- NOTE:**
1. The calibration interval of the above test instruments is 12 months and the calibrations are traceable to NML/ROC and NIST/USA.
 2. The test was performed in HwaYa Chamber 3.
 3. The horn antenna and HP preamplifier (model: 8449B) are used only for the measurement of emission frequency above 1GHz if tested.
 4. The IC Site Registration No. is IC4924-4.



4.2.3 TEST PROCEDURES

- a. The EUT was placed on the top of a rotating table 0.8 meters above the ground at a 3 meter semi-anechoic chamber. The table was rotated 360 degrees to determine the position of the highest radiation.
- b. The EUT was set 3 meters away from the interference-receiving antenna, which was mounted on the top of a variable-height antenna tower.
- c. The antenna is a broadband antenna, and its height is varied from one meter to four meters above the ground to determine the maximum value of the field strength. Both horizontal and vertical polarizations of the antenna are set to make the measurement.
- d. For each suspected emission, the EUT was arranged to its worst case and then the antenna was tuned to heights from 1 meter to 4 meters and the rotatable table was turned from 0 degrees to 360 degrees to find the maximum reading.
- e. The test-receiver system was set to Peak Detect Function and Specified Bandwidth with Maximum Hold Mode.
- f. If the emission level of the EUT in peak mode was 10 dB lower than the limit specified, then testing could be stopped and the peak values of the EUT would be reported. Otherwise the emissions that did not have 10 dB margin would be re-tested one by one using peak, quasi-peak or average method as specified and then reported in a data sheet.

NOTE:

1. The resolution bandwidth and video bandwidth of test receiver/spectrum analyzer is 120kHz for Peak detection (PK) and Quasi-peak detection (QP) at frequency below 1GHz.
2. The resolution bandwidth and video bandwidth of test receiver/spectrum analyzer is 1 MHz for Peak detection at frequency above 1GHz.
3. The resolution bandwidth of test receiver/spectrum analyzer is 1 MHz and the video bandwidth is 10kHz for Average detection (AV) at frequency above 1GHz.

4.2.4 DEVIATION FROM TEST STANDARD

No deviation

4.2.5 TEST SETUP

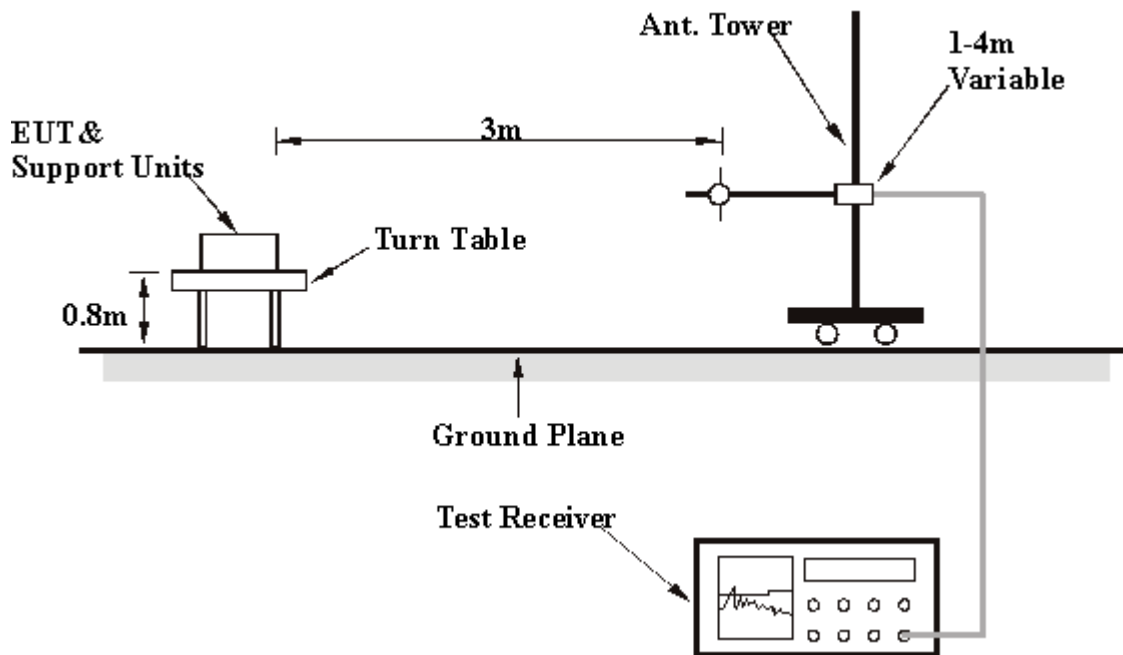

For the actual test configuration, please refer to the related item – Photographs of the Test Configuration.

4.2.6 EUT OPERATING CONDITIONS

Same as 4.1.6



4.2.7 TEST RESULTS

RADIATED WORST-CASE DATA: BELOW 1GHz

EUT	ADSL Modem with Wireless Pre-N Router	MEASUREMENT DETAIL	
MODEL	F5D8630-4	FREQUENCY RANGE	Below 1000MHz
CHANNEL	Channel 11	DETECTOR FUNCTION	Quasi-Peak
MODULATION TYPE	BPSK	ENVIRONMENTAL CONDITIONS	23deg. C, 64%RH, 991hPa
TRANSFER RATE	6Mbps	INPUT POWER (SYSTEM)	120Vac, 60 Hz
TESTED BY	Brad Wu		

ANTENNA POLARITY & TEST DISTANCE: HORIZONTAL AT 3 M

No.	Freq. (MHz)	Emission Level (dBuV/m)	Limit (dBuV/m)	Margin (dB)	Antenna Height (m)	Table Angle (Degree)	Raw Value (dBuV)	Correction Factor (dB/m)
1	249.66	37.44 QP	46.00	-8.56	1.00 H	145	24.34	13.11
2	300.20	32.48 QP	46.00	-13.52	1.00 H	121	18.07	14.41
3	350.74	31.43 QP	46.00	-14.57	1.00 H	184	15.89	15.54
4	512.08	31.71 QP	46.00	-14.29	1.50 H	223	12.93	18.79
5	560.68	43.06 QP	46.00	-2.94	1.00 H	124	23.30	19.75
6	896.97	33.21 QP	46.00	-12.79	1.25 H	295	8.45	24.76

ANTENNA POLARITY & TEST DISTANCE: VERTICAL AT 3 M

No.	Freq. (MHz)	Emission Level (dBuV/m)	Limit (dBuV/m)	Margin (dB)	Antenna Height (m)	Table Angle (Degree)	Raw Value (dBuV)	Correction Factor (dB/m)
1	30.00	38.77 QP	40.00	-1.23	1.50 V	157	25.10	13.67
2	72.77	36.70 QP	40.00	-3.30	1.00 V	217	24.94	11.76
3	249.66	33.96 QP	46.00	-12.04	1.00 V	172	20.85	13.11
4	560.68	42.88 QP	46.00	-3.12	1.00 V	196	23.13	19.75
5	599.56	30.08 QP	46.00	-15.92	1.25 V	40	9.26	20.82
6	702.59	30.78 QP	46.00	-15.22	1.00 V	217	8.71	22.07

- REMARKS:**
1. Emission level (dBuV/m) = Raw Value (dBuV) + Correction Factor (dB/m).
 2. Correction Factor (dB/m) = Antenna Factor (dB/m) + Cable Factor (dB).
 3. The other emission levels were very low against the limit.
 4. Margin value = Emission level – Limit value.



802.11b DSSS MODULATION

EUT	ADSL Modem with Wireless Pre-N Router	MEASUREMENT DETAIL	
MODEL	F5D8630-4	FREQUENCY RANGE	1 ~ 25GHz
CHANNEL	Channel 1	DETECTOR FUNCTION	Peak (PK) Average (AV)
MODULATION TYPE	BPSK	ENVIRONMENTAL CONDITIONS	21deg. C, 62%RH, 991hPa
TRANSFER RATE	1Mbps	INPUT POWER (SYSTEM)	120Vac, 60 Hz
TESTED BY	Brad Wu		

ANTENNA POLARITY & TEST DISTANCE: HORIZONTAL AT 3 M

No.	Freq. (MHz)	Emission Level (dBuV/m)	Limit (dBuV/m)	Margin (dB)	Antenna Height (m)	Table Angle (Degree)	Raw Value (dBuV)	Correction Factor (dB/m)
1	1680.00	47.65 PK	74.00	-26.35	1.52 H	291	17.06	30.59
1	1680.00	43.54 AV	54.00	-10.46	1.52 H	291	12.95	30.59
2	2386.00	50.18 PK	74.00	-23.82	1.20 H	253	17.63	32.55
2	2386.00	46.51 AV	54.00	-7.49	1.20 H	253	13.96	32.55
3	*2412.00	101.02 PK			1.20 H	253	68.41	32.61
3	*2412.00	97.35 AV			1.20 H	253	64.74	32.61
4	4824.00	47.13 PK	74.00	-26.87	1.06 H	219	7.29	39.84
4	4824.00	40.24 AV	54.00	-13.76	1.06 H	219	0.40	39.84

ANTENNA POLARITY & TEST DISTANCE: VERTICAL AT 3 M

No.	Freq. (MHz)	Emission Level (dBuV/m)	Limit (dBuV/m)	Margin (dB)	Antenna Height (m)	Table Angle (Degree)	Raw Value (dBuV)	Correction Factor (dB/m)
1	1680.00	46.65 PK	74.00	-27.35	1.04 V	29	16.06	30.59
1	1680.00	43.37 AV	54.00	-10.63	1.04 V	29	12.78	30.59
2	2386.00	61.13 PK	74.00	-12.87	1.17 V	2	28.58	32.55
2	2386.00	52.44 AV	54.00	-1.56	1.17 V	2	19.89	32.55
3	*2412.00	106.94 PK			1.18 V	12	74.33	32.61
3	*2412.00	103.14 AV			1.18 V	12	70.53	32.61
4	4824.00	52.47 PK	74.00	-21.53	1.02 V	242	12.63	39.84
4	4824.00	46.51 AV	54.00	-7.49	1.02 V	242	6.67	39.84

- REMARKS:**
1. Emission level (dBuV/m) = Raw Value (dBuV) + Correction Factor (dB/m).
 2. Correction Factor (dB/m) = Antenna Factor (dB/m) + Cable Factor (dB).
 3. The other emission levels were very low against the limit.
 4. Margin value = Emission level – Limit value.
 5. “ * “: Fundamental frequency.



EUT	ADSL Modem with Wireless Pre-N Router	MEASUREMENT DETAIL	
MODEL	F5D8630-4	FREQUENCY RANGE	1 ~ 25GHz
CHANNEL	Channel 6	DETECTOR FUNCTION	Peak (PK) Average (AV)
MODULATION TYPE	BPSK	ENVIRONMENTAL CONDITIONS	21deg. C, 62%RH, 991hPa
TRANSFER RATE	1Mbps	INPUT POWER (SYSTEM)	120Vac, 60 Hz
TESTED BY	Brad Wu		

ANTENNA POLARITY & TEST DISTANCE: HORIZONTAL AT 3 M

No.	Freq. (MHz)	Emission Level (dBuV/m)	Limit (dBuV/m)	Margin (dB)	Antenna Height (m)	Table Angle (Degree)	Raw Value (dBuV)	Correction Factor (dB/m)
1	1740.00	48.31 PK	74.00	-25.69	1.61 H	327	17.53	30.78
1	1740.00	44.25 AV	54.00	-9.75	1.61 H	327	13.47	30.78
2	*2437.00	104.08 PK			1.22 H	257	71.41	32.67
2	*2437.00	100.47 AV			1.22 H	257	67.80	32.67
3	4874.00	48.08 PK	74.00	-25.92	1.03 H	198	8.03	40.05
3	4874.00	41.10 AV	54.00	-12.90	1.03 H	198	1.05	40.05

ANTENNA POLARITY & TEST DISTANCE: VERTICAL AT 3 M

No.	Freq. (MHz)	Emission Level (dBuV/m)	Limit (dBuV/m)	Margin (dB)	Antenna Height (m)	Table Angle (Degree)	Raw Value (dBuV)	Correction Factor (dB/m)
1	1740.00	48.89 PK	74.00	-25.11	1.00 V	30	18.11	30.78
1	1740.00	45.55 AV	54.00	-8.45	1.00 V	30	14.77	30.78
2	*2437.00	110.38 PK			1.15 V	5	77.71	32.67
2	*2437.00	106.78 AV			1.15 V	5	74.11	32.67
3	4874.00	53.81 PK	74.00	-20.19	1.00 V	176	13.76	40.05
3	4874.00	47.80 AV	54.00	-6.20	1.00 V	176	7.75	40.05

- REMARKS:**
1. Emission level (dBuV/m) = Raw Value (dBuV) + Correction Factor (dB/m).
 2. Correction Factor (dB/m) = Antenna Factor (dB/m) + Cable Factor (dB).
 3. The other emission levels were very low against the limit.
 4. Margin value = Emission level – Limit value.
 5. “ * “: Fundamental frequency.



EUT	ADSL Modem with Wireless Pre-N Router	MEASUREMENT DETAIL	
MODEL	F5D8630-4	FREQUENCY RANGE	1 ~ 25GHz
CHANNEL	Channel 11	DETECTOR FUNCTION	Peak (PK) Average (AV)
MODULATION TYPE	BPSK	ENVIRONMENTAL CONDITIONS	21deg. C, 62%RH, 991hPa
TRANSFER RATE	1Mbps	INPUT POWER (SYSTEM)	120Vac, 60 Hz
TESTED BY	Brad Wu		

ANTENNA POLARITY & TEST DISTANCE: HORIZONTAL AT 3 M

No.	Freq. (MHz)	Emission Level (dBuV/m)	Limit (dBuV/m)	Margin (dB)	Antenna Height (m)	Table Angle (Degree)	Raw Value (dBuV)	Correction Factor (dB/m)
1	1760.00	47.84 PK	74.00	-26.16	1.47 H	225	17.01	30.83
1	1760.00	43.76 AV	54.00	-10.24	1.47 H	225	12.93	30.83
2	*2462.00	103.24 PK			1.21 H	256	70.50	32.73
2	*2462.00	99.54 AV			1.21 H	256	66.81	32.73
3	2487.50	49.25 PK	74.00	-24.75	1.21 H	256	16.45	32.80
3	2487.50	45.55 AV	54.00	-8.45	1.21 H	256	12.75	32.80
4	4974.00	48.21 PK	74.00	-25.79	1.04 H	227	7.72	40.49
4	4974.00	41.36 AV	54.00	-12.64	1.04 H	227	0.87	40.49

ANTENNA POLARITY & TEST DISTANCE: VERTICAL AT 3 M

No.	Freq. (MHz)	Emission Level (dBuV/m)	Limit (dBuV/m)	Margin (dB)	Antenna Height (m)	Table Angle (Degree)	Raw Value (dBuV)	Correction Factor (dB/m)
1	1760.00	46.89 PK	74.00	-27.11	1.01 V	68	16.06	30.83
1	1760.00	43.54 AV	54.00	-10.46	1.01 V	68	12.71	30.83
2	*2462.00	108.53 PK			1.13 V	14	75.79	32.73
2	*2462.00	104.69 AV			1.13 V	14	71.96	32.73
3	2487.50	55.54 PK	74.00	-18.46	1.13 V	14	22.74	32.80
3	2487.50	51.70 AV	54.00	-2.30	1.13 V	14	18.90	32.80
4	4924.00	52.54 PK	74.00	-21.46	1.01 V	258	12.27	40.27
4	4924.00	46.62 AV	54.00	-7.38	1.01 V	258	6.35	40.27

- REMARKS:**
1. Emission level (dBuV/m) = Raw Value (dBuV) + Correction Factor (dB/m).
 2. Correction Factor (dB/m) = Antenna Factor (dB/m) + Cable Factor (dB).
 3. The other emission levels were very low against the limit.
 4. Margin value = Emission level – Limit value.
 5. “ * “: Fundamental frequency.



802.11g OFDM MODULATION

EUT	ADSL Modem with Wireless Pre-N Router	MEASUREMENT DETAIL	
MODEL	F5D8630-4	FREQUENCY RANGE	1 ~ 25GHz
CHANNEL	Channel 1	DETECTOR FUNCTION	Peak (PK) Average (AV)
MODULATION TYPE	BPSK	ENVIRONMENTAL CONDITIONS	22deg. C, 67%RH, 991hPa
TRANSFER RATE	6Mbps	INPUT POWER (SYSTEM)	120Vac, 60 Hz
TESTED BY	Brad Wu		

ANTENNA POLARITY & TEST DISTANCE: HORIZONTAL AT 3 M

No.	Freq. (MHz)	Emission Level (dBuV/m)	Limit (dBuV/m)	Margin (dB)	Antenna Height (m)	Table Angle (Degree)	Raw Value (dBuV)	Correction Factor (dB/m)
1	1680.00	44.47 PK	74.00	-29.53	1.02 H	49	13.88	30.59
1	1680.00	41.23 AV	54.00	-12.77	1.02 H	49	10.64	30.59
2	2390.00	51.44 PK	74.00	-22.56	1.17 H	173	18.88	32.56
2	2390.00	41.90 AV	54.00	-12.10	1.17 H	173	9.34	32.56
3	*2412.00	97.14 PK			1.17 H	173	64.53	32.61
3	*2412.00	87.60 AV			1.17 H	173	54.99	32.61
4	4824.00	49.68 PK	74.00	-24.32	1.07 H	223	9.84	39.84
4	4824.00	37.54 AV	54.00	-16.46	1.07 H	223	-2.30	39.84

ANTENNA POLARITY & TEST DISTANCE: VERTICAL AT 3 M

No.	Freq. (MHz)	Emission Level (dBuV/m)	Limit (dBuV/m)	Margin (dB)	Antenna Height (m)	Table Angle (Degree)	Raw Value (dBuV)	Correction Factor (dB/m)
1	1680.00	45.53 PK	74.00	-28.47	1.05 V	36	14.94	30.59
1	1680.00	42.29 AV	54.00	-11.71	1.05 V	36	11.70	30.59
2	2390.00	65.58 PK	74.00	-8.42	1.22 V	1	33.02	32.56
2	2390.00	52.50 AV	54.00	-1.50	1.22 V	1	19.94	32.56
3	*2412.00	107.58 PK			1.22 V	8	74.97	32.61
3	*2412.00	98.20 AV			1.22 V	8	65.59	32.61
4	4824.00	50.70 PK	74.00	-23.30	1.00 V	204	10.86	39.84
4	4824.00	38.62 AV	54.00	-15.38	1.00 V	204	-1.22	39.84

- REMARKS:**
1. Emission level (dBuV/m) = Raw Value (dBuV) + Correction Factor (dB/m).
 2. Correction Factor (dB/m) = Antenna Factor (dB/m) + Cable Factor (dB).
 3. The other emission levels were very low against the limit.
 4. Margin value = Emission level – Limit value.
 5. “ * “: Fundamental frequency.



EUT	ADSL Modem with Wireless Pre-N Router	MEASUREMENT DETAIL	
MODEL	F5D8630-4	FREQUENCY RANGE	1 ~ 25GHz
CHANNEL	Channel 6	DETECTOR FUNCTION	Peak (PK) Average (AV)
MODULATION TYPE	BPSK	ENVIRONMENTAL CONDITIONS	22deg. C, 67%RH, 991hPa
TRANSFER RATE	6Mbps	INPUT POWER (SYSTEM)	120Vac, 60 Hz
TESTED BY	Brad Wu		

ANTENNA POLARITY & TEST DISTANCE: HORIZONTAL AT 3 M

No.	Freq. (MHz)	Emission Level (dBuV/m)	Limit (dBuV/m)	Margin (dB)	Antenna Height (m)	Table Angle (Degree)	Raw Value (dBuV)	Correction Factor (dB/m)
1	1740.00	48.35 PK	74.00	-25.65	1.06 H	72	17.57	30.78
1	1740.00	45.63 AV	54.00	-8.37	1.06 H	72	14.85	30.78
2	*2437.00	96.83 PK			1.18 H	176	64.16	32.67
2	*2437.00	87.38 AV			1.18 H	176	54.71	32.67
3	4874.00	49.76 PK	74.00	-24.24	1.09 H	241	9.71	40.05
3	4874.00	37.62 AV	54.00	-16.38	1.09 H	241	-2.43	40.05

ANTENNA POLARITY & TEST DISTANCE: VERTICAL AT 3 M

No.	Freq. (MHz)	Emission Level (dBuV/m)	Limit (dBuV/m)	Margin (dB)	Antenna Height (m)	Table Angle (Degree)	Raw Value (dBuV)	Correction Factor (dB/m)
1	1740.00	50.28 PK	74.00	-23.72	1.00 V	46	19.50	30.78
1	1740.00	47.52 AV	54.00	-6.48	1.00 V	46	16.74	30.78
2	*2437.00	107.18 PK			1.20 V	1	74.51	32.67
2	*2437.00	97.55 AV			1.20 V	1	64.88	32.67
3	4874.00	50.56 PK	74.00	-23.44	1.04 V	211	10.51	40.05
3	4874.00	38.49 AV	54.00	-15.51	1.04 V	211	-1.56	40.05

- REMARKS:**
1. Emission level (dBuV/m) = Raw Value (dBuV) + Correction Factor (dB/m).
 2. Correction Factor (dB/m) = Antenna Factor (dB/m) + Cable Factor (dB).
 3. The other emission levels were very low against the limit.
 4. Margin value = Emission level – Limit value.
 5. “ * “: Fundamental frequency.



EUT	ADSL Modem with Wireless Pre-N Router	MEASUREMENT DETAIL	
MODEL	F5D8630-4	FREQUENCY RANGE	1 ~ 25GHz
CHANNEL	Channel 11	DETECTOR FUNCTION	Peak (PK) Average (AV)
MODULATION TYPE	BPSK	ENVIRONMENTAL CONDITIONS	22deg. C, 67%RH, 991hPa
TRANSFER RATE	6Mbps	INPUT POWER (SYSTEM)	120Vac, 60 Hz
TESTED BY	Brad Wu		

ANTENNA POLARITY & TEST DISTANCE: HORIZONTAL AT 3 M

No.	Freq. (MHz)	Emission Level (dBuV/m)	Limit (dBuV/m)	Margin (dB)	Antenna Height (m)	Table Angle (Degree)	Raw Value (dBuV)	Correction Factor (dB/m)
1	1760.00	48.52 PK	74.00	-25.48	1.03 H	67	17.69	30.83
1	1760.00	46.21 AV	54.00	-7.79	1.03 H	67	15.38	30.83
2	*2462.00	98.26 PK			1.19 H	171	65.53	32.73
2	*2462.00	88.74 AV			1.19 H	171	56.00	32.73
3	2483.50	48.38 PK	74.00	-25.62	1.19 H	171	15.59	32.79
3	2483.50	38.86 AV	54.00	-15.14	1.19 H	171	6.07	32.79
4	4924.00	51.48 PK	74.00	-22.52	1.01 H	198	11.21	40.27
4	4924.00	45.56 AV	54.00	-8.44	1.01 H	198	5.29	40.27

ANTENNA POLARITY & TEST DISTANCE: VERTICAL AT 3 M

No.	Freq. (MHz)	Emission Level (dBuV/m)	Limit (dBuV/m)	Margin (dB)	Antenna Height (m)	Table Angle (Degree)	Raw Value (dBuV)	Correction Factor (dB/m)
1	1760.00	51.68 PK	74.00	-22.32	1.00 V	43	20.85	30.83
1	1760.00	49.33 AV	54.00	-4.67	1.00 V	43	18.50	30.83
2	*2462.00	108.55 PK			1.16 V	6	75.82	32.73
2	*2462.00	99.30 AV			1.16 V	6	66.56	32.73
3	2483.50	58.67 PK	74.00	-15.33	1.16 V	6	25.88	32.79
3	2483.50	49.42 AV	54.00	-4.58	1.16 V	6	16.63	32.79
4	4924.00	53.52 PK	74.00	-20.48	1.07 V	196	13.25	40.27
4	4924.00	47.63 AV	54.00	-6.37	1.07 V	196	7.36	40.27

- REMARKS:**
1. Emission level (dBuV/m) = Raw Value (dBuV) + Correction Factor (dB/m).
 2. Correction Factor (dB/m) = Antenna Factor (dB/m) + Cable Factor (dB).
 3. The other emission levels were very low against the limit.
 4. Margin value = Emission level – Limit value.
 5. “ * “: Fundamental frequency.



4.3 6dB BANDWIDTH MEASUREMENT

4.3.1 LIMITS OF 6dB BANDWIDTH MEASUREMENT

The minimum of 6dB Bandwidth Measurement is 0.5 MHz.

4.3.2 TEST INSTRUMENTS

DESCRIPTION & MANUFACTURER	MODEL NO.	SERIAL NO.	CALIBRATED UNTIL
SPECTRUM ANALYZER	FSEK30	100049	Aug. 14, 2006

NOTE: The calibration interval of the above test instruments is 12 months and the calibrations are traceable to NML/ROC and NIST/USA.

4.3.3 TEST PROCEDURE

The transmitter output was connected to the spectrum analyzer through an attenuator. The bandwidth of the fundamental frequency was measured by spectrum analyzer with 100 kHz RBW and 100kHz VBW. The 6dB bandwidth is defined as the total spectrum the power of which is higher than peak power minus 6dB.

4.3.4 DEVIATION FROM TEST STANDARD

No deviation

4.3.5 TEST SETUP

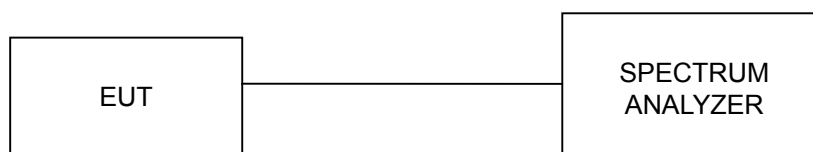

For the actual test configuration, please refer to the related Item – Photographs of the Test Configuration.

4.3.6 EUT OPERATING CONDITIONS

The software provided by client to enable the EUT under transmission condition continuously at lowest, middle and highest channel frequencies individually.



4.3.7 TEST RESULTS

802.11b DSSS MODULATION

EUT	ADSL Modem with Wireless Pre-N Router	MODEL	F5D8630-4
MODULATION TYPE	BPSK	TRANSFER RATE	1Mbps
INPUT POWER (SYSTEM)	120Vac, 60 Hz	ENVIRONMENTAL CONDITIONS	23deg. C, 64%RH, 991hPa
TESTED BY	Brad Wu		

CHANNEL	CHANNEL FREQUENCY (MHz)	6dB BANDWIDTH (MHz)	MINIMUM LIMIT (MHz)	PASS/FAIL
1	2412	10.12	0.5	PASS
6	2437	10.16	0.5	PASS
11	2462	10.12	0.5	PASS



CH1

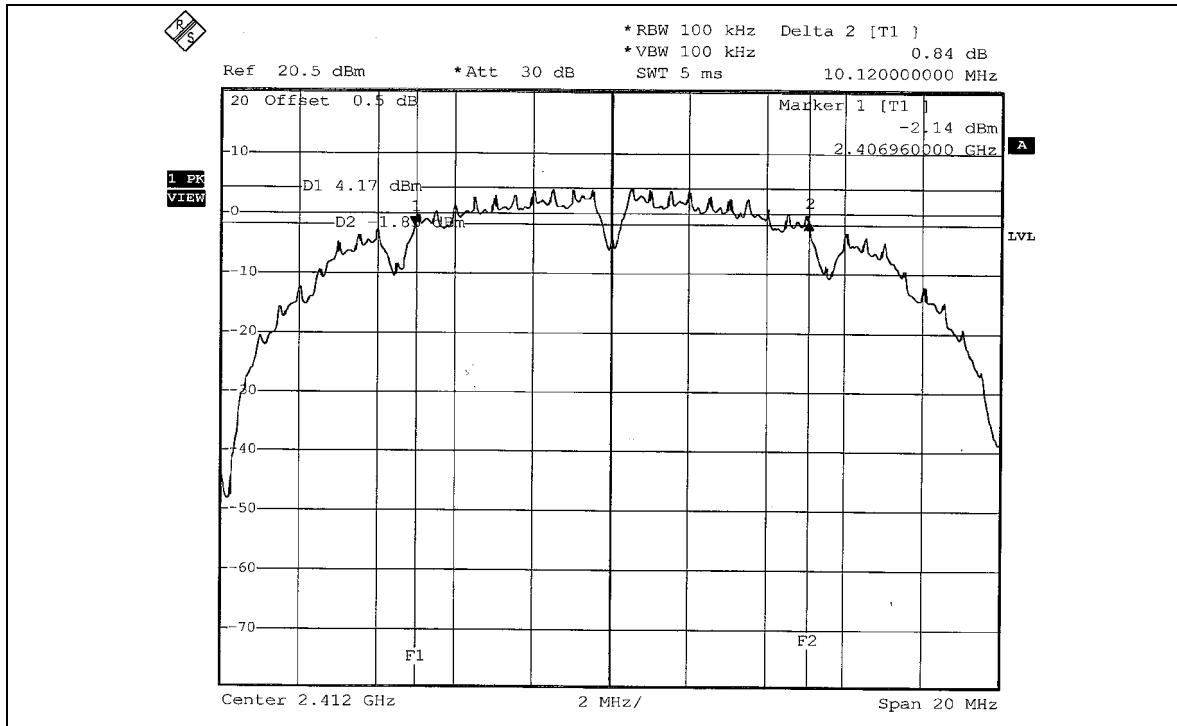

CH6

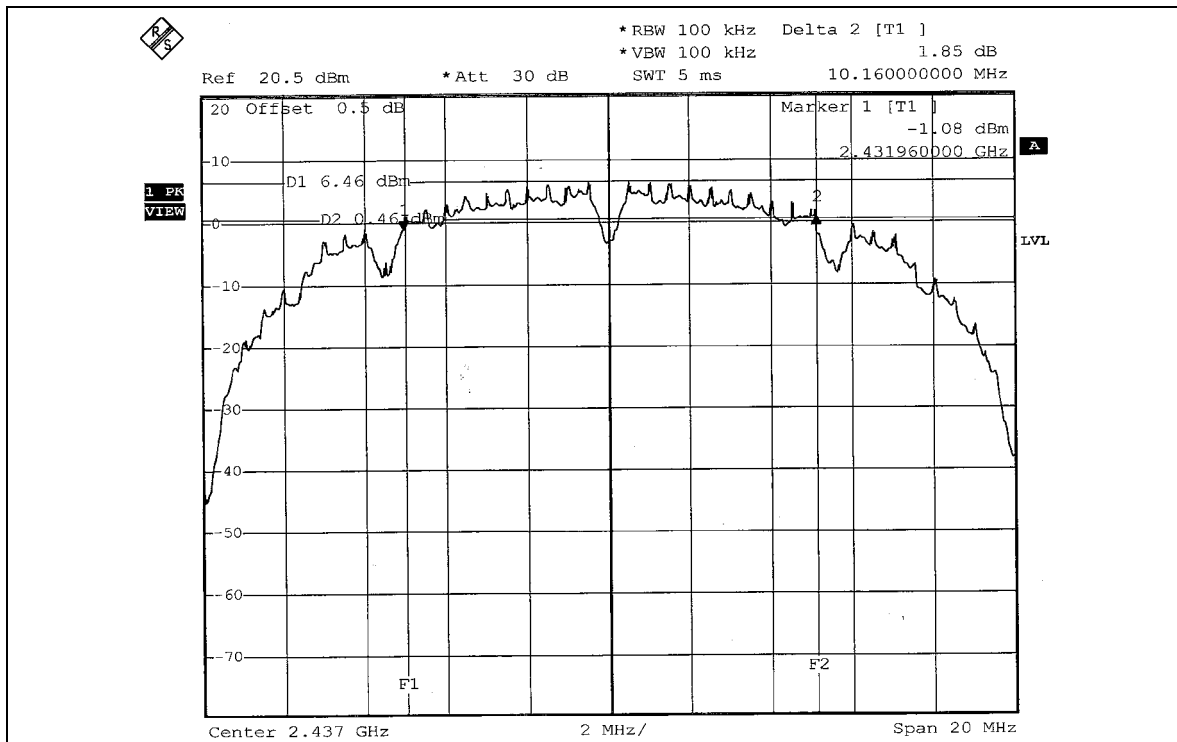



CH11

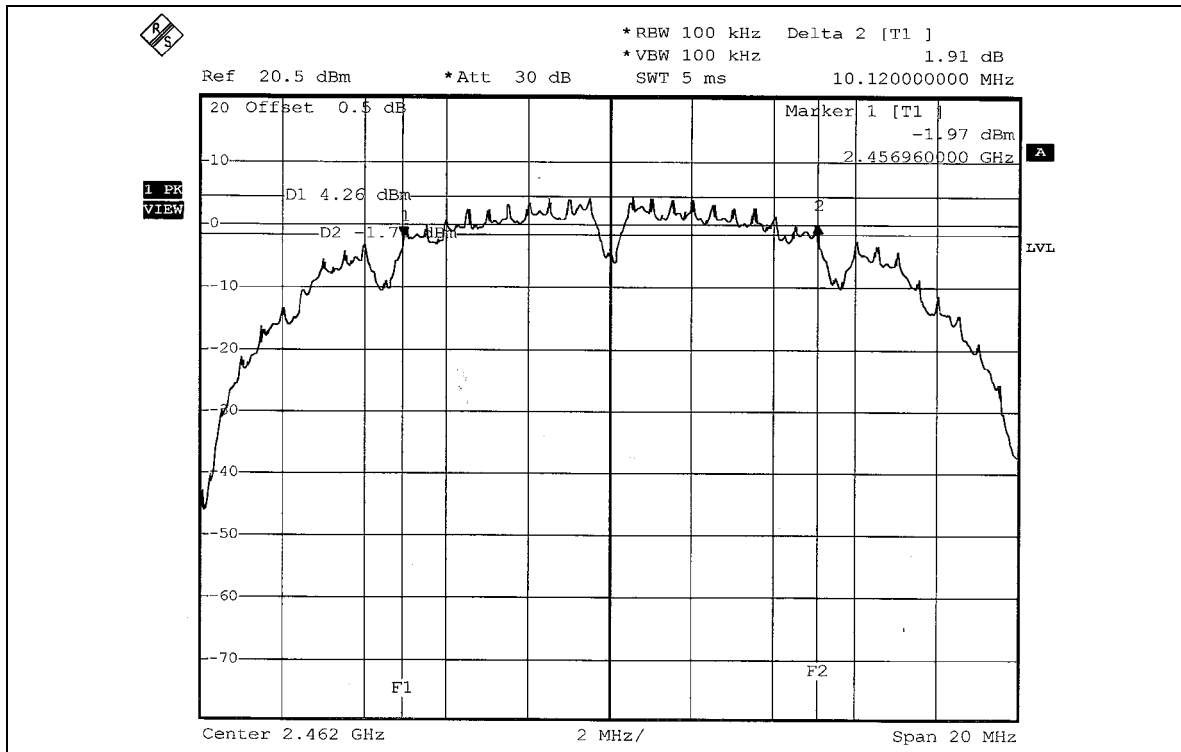



802.11g OFDM MODULATION

EUT	ADSL Modem with Wireless Pre-N Router	MODEL	F5D8630-4
MODULATION TYPE	BPSK	TRANSFER RATE	6Mbps
INPUT POWER (SYSTEM)	120Vac, 60 Hz	ENVIRONMENTAL CONDITIONS	23deg. C, 64%RH, 991hPa
TESTED BY	Brad Wu		

CHANNEL	CHANNEL FREQUENCY (MHz)	6dB BANDWIDTH (MHz)	MINIMUM LIMIT (MHz)	PASS/FAIL
1	2412	15.12	0.5	PASS
6	2437	15.36	0.5	PASS
11	2462	15.32	0.5	PASS



CH1

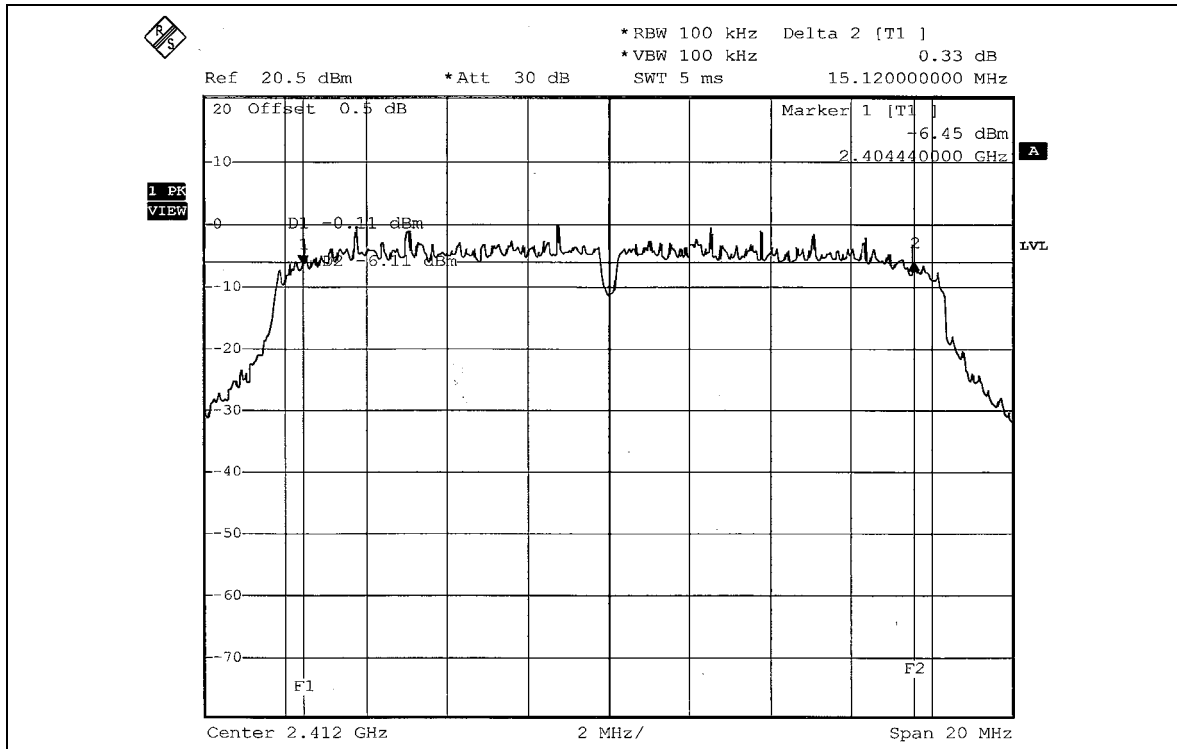

CH6

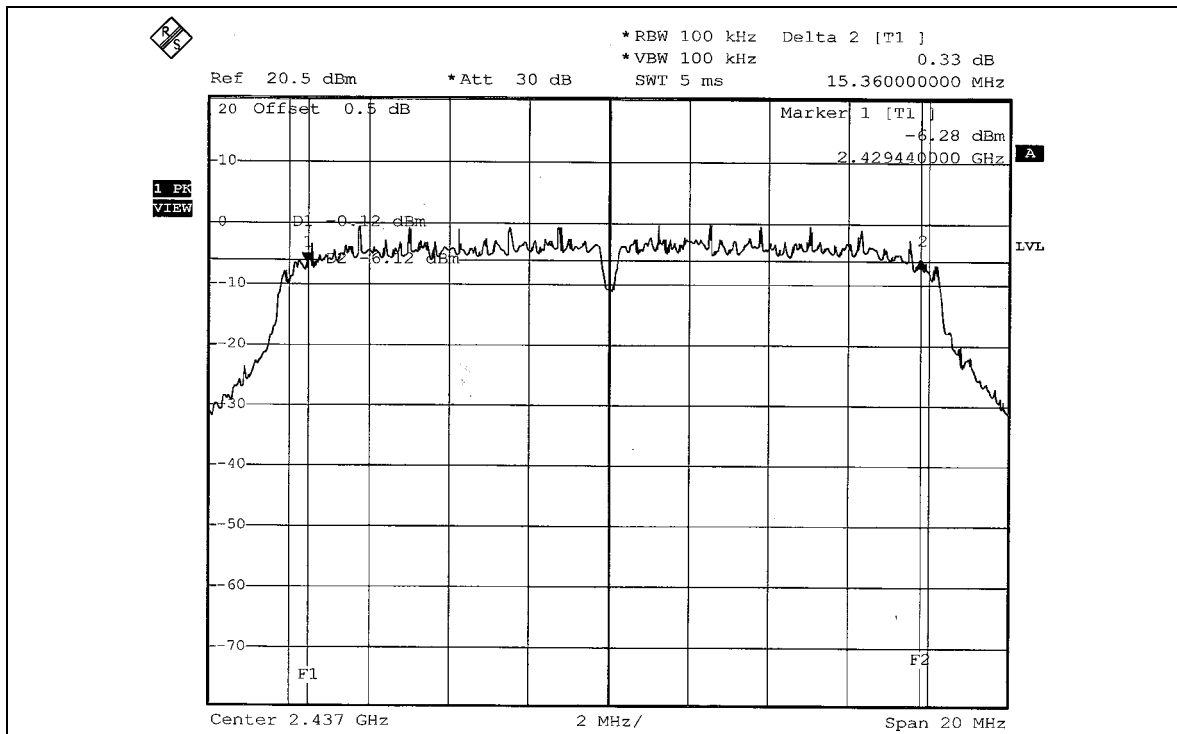



CH11

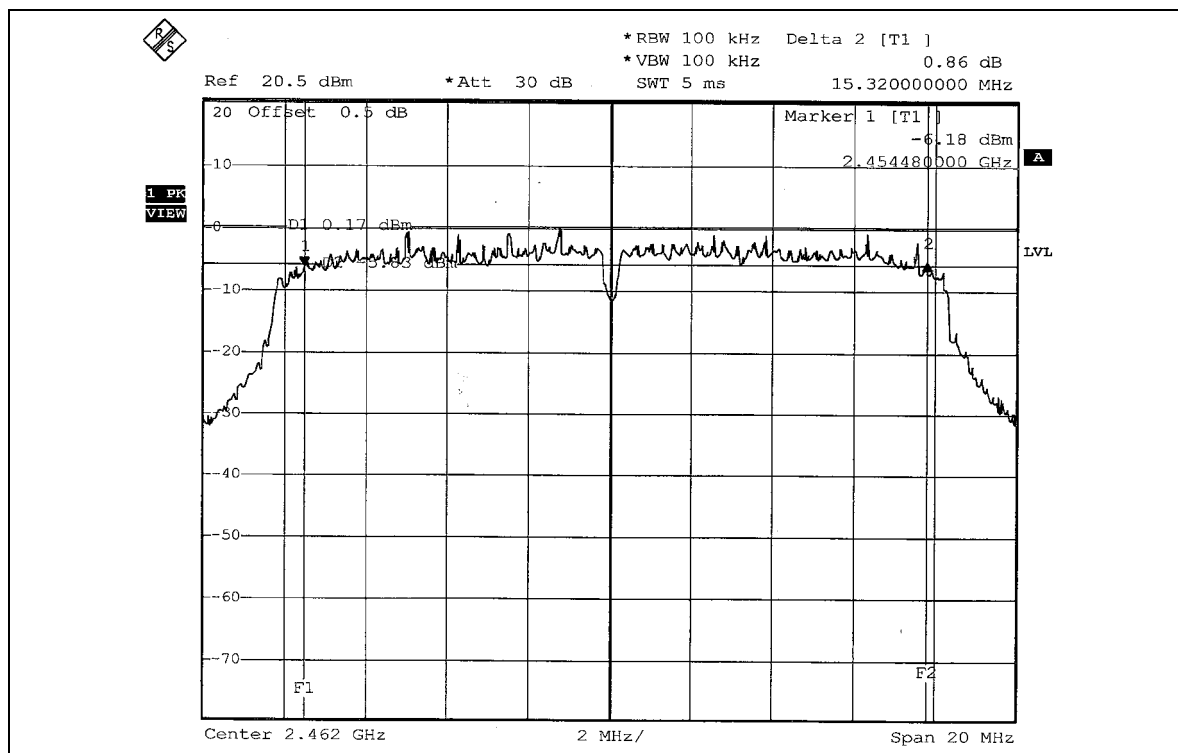



4.4 MAXIMUM PEAK OUTPUT POWER

4.4.1 LIMITS OF MAXIMUM PEAK OUTPUT POWER MEASUREMENT

The Maximum Peak Output Power Measurement is 30dBm.

4.4.2 TEST INSTRUMENTS

DESCRIPTION & MANUFACTURER	MODEL NO.	SERIAL NO.	CALIBRATED UNTIL
R&S SPECTRUM ANALYZER	FSEK30	100049	Aug. 14, 2006
AGILENT SIGNAL GENERATOR	E8257C	MY43320668	Dec. 06, 2005
DIGITAL RT OSCILLOSCOPE	TDS1012	C037299	Dec. 07, 2005
NARDA DETECTOR	4503A	FSCM99899	NA

NOTE: The calibration interval of the above test instruments is 12 months and the calibrations are traceable to NML/ROC and NIST/USA.



4.4.3 TEST PROCEDURES

1. A detector was used on the output port of the EUT. An oscilloscope was used to peak the response of the detector.
2. Replaced the EUT by the signal generator. The center frequency of the S.G was adjusted to the center frequency of the measured channel.
3. Adjusted the power to have the same peak reading on oscilloscope. Record the power level.

4.4.4 DEVIATION FROM TEST STANDARD

No deviation

4.4.5 TEST SETUP



4.4.6 EUT OPERATING CONDITIONS

Same as Item 4.3.6



4.4.7 TEST RESULTS

802.11b DSSS MODULATION

EUT	ADSL Modem with Wireless Pre-N Router	MODEL	F5D8630-4
MODULATION TYPE	BPSK	TRANSFER RATE	1Mbps
INPUT POWER (SYSTEM)	120Vac, 60 Hz	ENVIRONMENTAL CONDITIONS	23deg. C, 64%RH, 991hPa
TESTED BY	Brad Wu		

CHANNEL	CHANNEL FREQUENCY (MHz)	PEAK POWER OUTPUT (mW)	PEAK POWER OUTPUT (dBm)	PEAK POWER LIMIT (dBm)	PASS/FAIL
1	2412	40.365	16.06	30	PASS
6	2437	65.013	18.13	30	PASS
11	2462	40.087	16.03	30	PASS

802.11g OFDM MODULATION

EUT	ADSL Modem with Wireless Pre-N Router	MODEL	F5D8630-4
MODULATION TYPE	BPSK	TRANSFER RATE	6Mbps
INPUT POWER (SYSTEM)	120Vac, 60 Hz	ENVIRONMENTAL CONDITIONS	23deg. C, 64%RH, 991hPa
TESTED BY	Brad Wu		

CHANNEL	CHANNEL FREQUENCY (MHz)	PEAK POWER OUTPUT (mW)	PEAK POWER OUTPUT (dBm)	PEAK POWER LIMIT (dBm)	PASS/FAIL
1	2412	32.137	15.07	30	PASS
6	2437	32.285	15.09	30	PASS
11	2462	32.211	15.08	30	PASS



4.5 POWER SPECTRAL DENSITY MEASUREMENT

4.5.1 LIMITS OF POWER SPECTRAL DENSITY MEASUREMENT

The Maximum of Power Spectral Density Measurement is 8dBm.

4.5.2 TEST INSTRUMENTS

DESCRIPTION & MANUFACTURER	MODEL NO.	SERIAL NO.	CALIBRATED UNTIL
SPECTRUM ANALYZER	FSEK30	100049	Aug. 14, 2006

NOTE: The calibration interval of the above test instruments is 12 months and the calibrations are traceable to NML/ROC and NIST/USA.

4.5.3 TEST PROCEDURE

The transmitter output was connected to the spectrum analyzer through an attenuator, the bandwidth of the fundamental frequency was measured with the spectrum analyzer using 3kHz RBW and 30kHz VBW, set sweep time=span/3kHz. The power spectral density was measured and recorded.

The sweep time is allowed to be longer than span/3kHz for a full response of the mixer in the spectrum analyzer.

4.5.4 DEVIATION FROM TEST STANDARD

No deviation

4.5.5 TEST SETUP



4.5.6 EUT OPERATING CONDITIONS

Same as 4.3.6



4.5.7 TEST RESULTS

802.11b DSSS MODULATION

EUT	ADSL Modem with Wireless Pre-N Router	MODEL	F5D8630-4
MODULATION TYPE	BPSK	TRANSFER RATE	1Mbps
INPUT POWER (SYSTEM)	120Vac, 60 Hz	ENVIRONMENTAL CONDITIONS	23deg. C, 64%RH, 991hPa
TESTED BY	Brad Wu		

CHANNEL	CHANNEL FREQUENCY (MHz)	RF POWER LEVEL IN 3 kHz BW (dBm)	MAXIMUM LIMIT (dBm)	PASS/FAIL
1	2412	-11.26	8	PASS
6	2437	-8.82	8	PASS
11	2462	-11.40	8	PASS



CH1

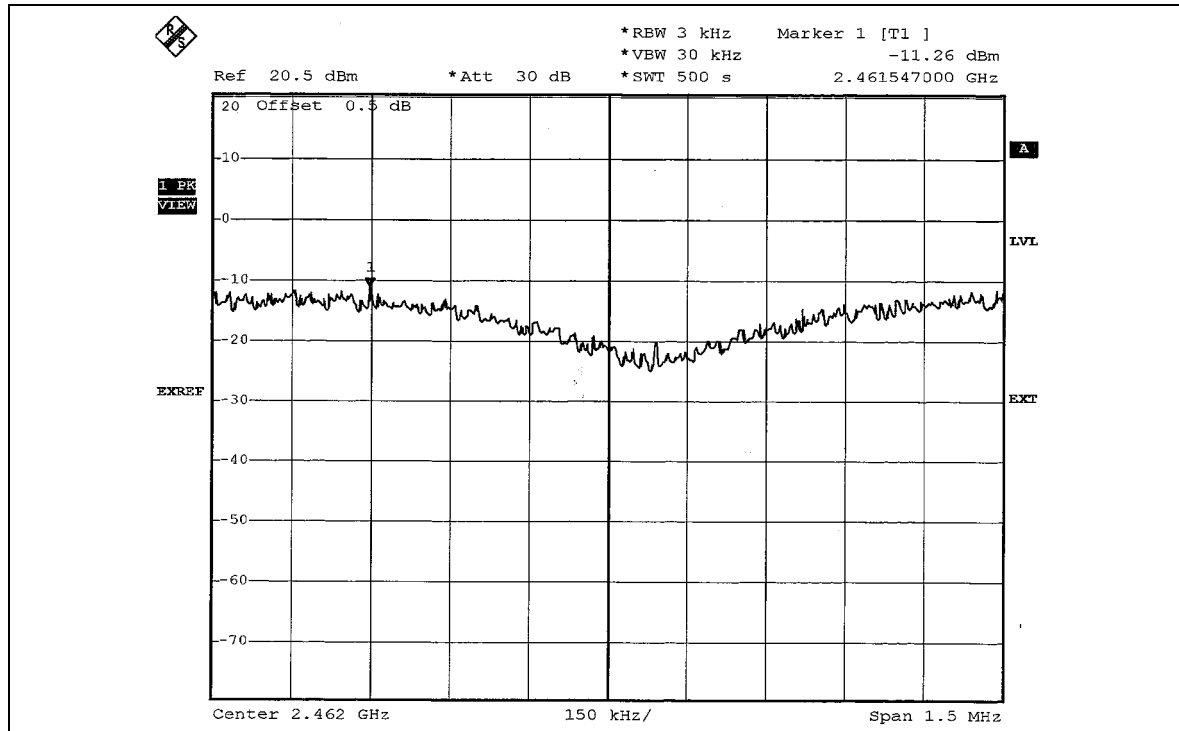

CH6

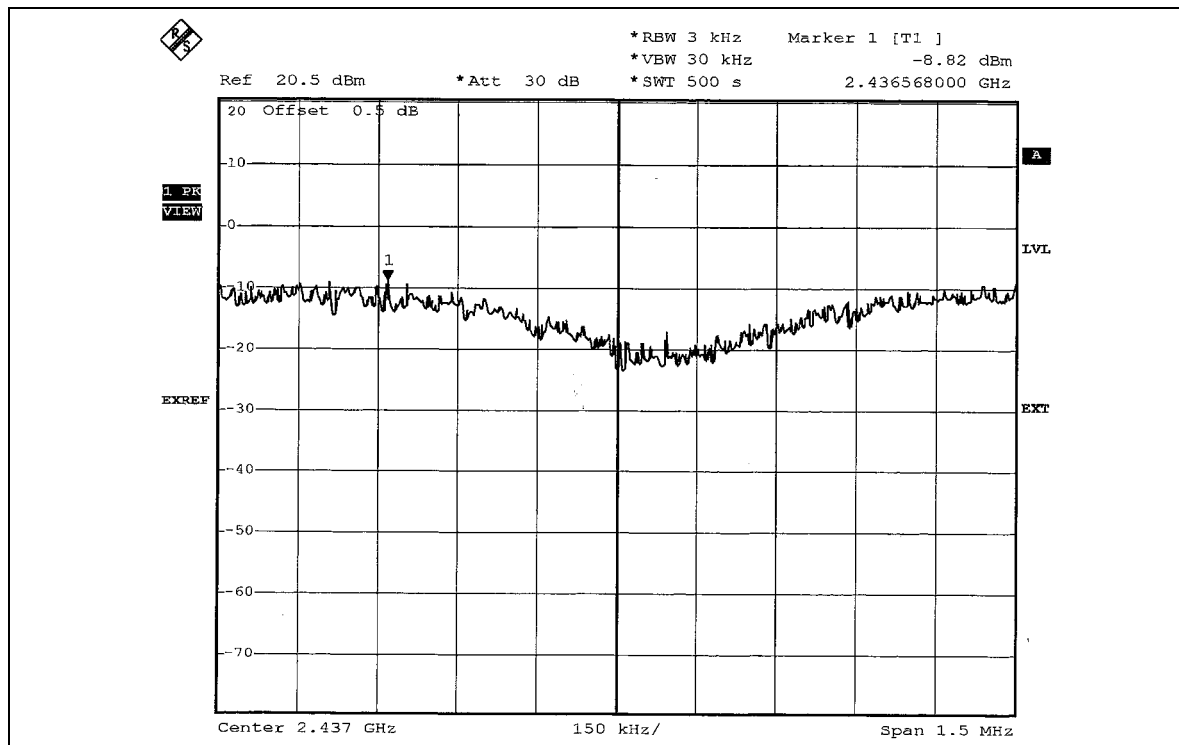



CH11

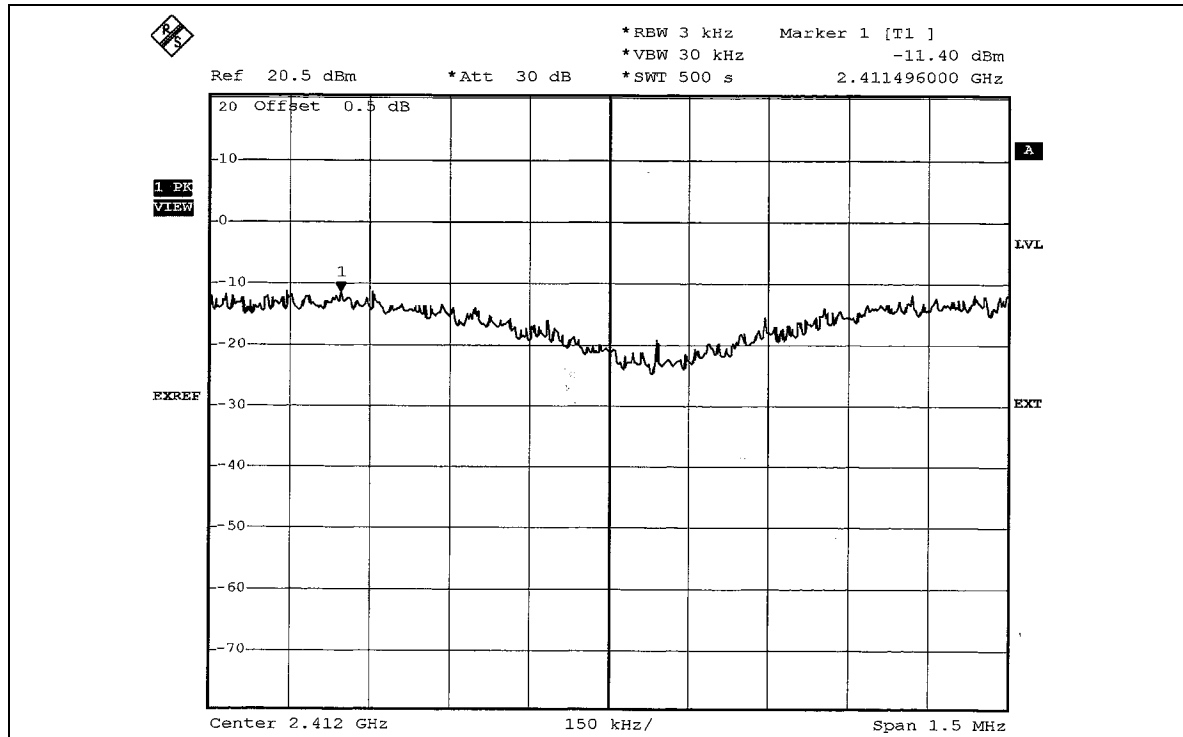



802.11g OFDM MODULATION

EUT	ADSL Modem with Wireless Pre-N Router	MODEL	F5D8630-4
MODULATION TYPE	BPSK	TRANSFER RATE	6Mbps
INPUT POWER (SYSTEM)	120Vac, 60 Hz	ENVIRONMENTAL CONDITIONS	23deg. C, 64%RH, 991hPa
TESTED BY	Brad Wu		

CHANNEL	CHANNEL FREQUENCY (MHz)	RF POWER LEVEL IN 3 kHz BW (dBm)	MAXIMUM LIMIT (dBm)	PASS/FAIL
1	2412	-14.14	8	PASS
6	2437	-14.30	8	PASS
11	2462	-14.31	8	PASS



CH1

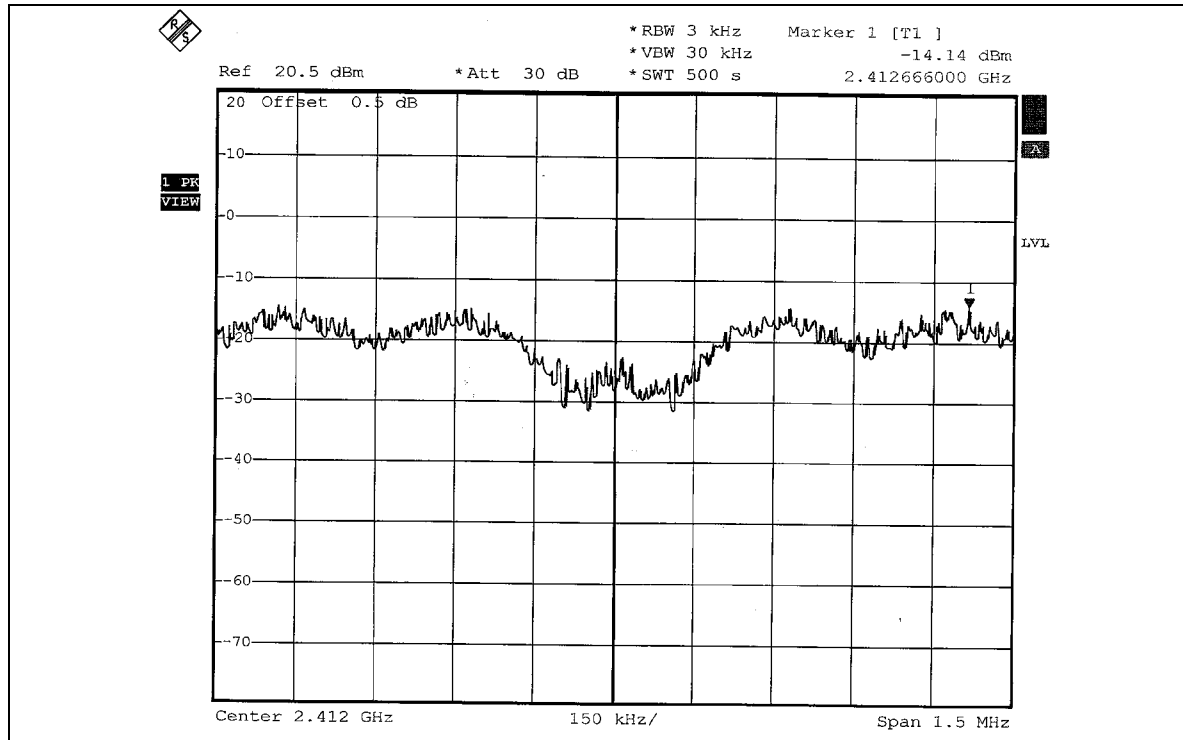

CH6

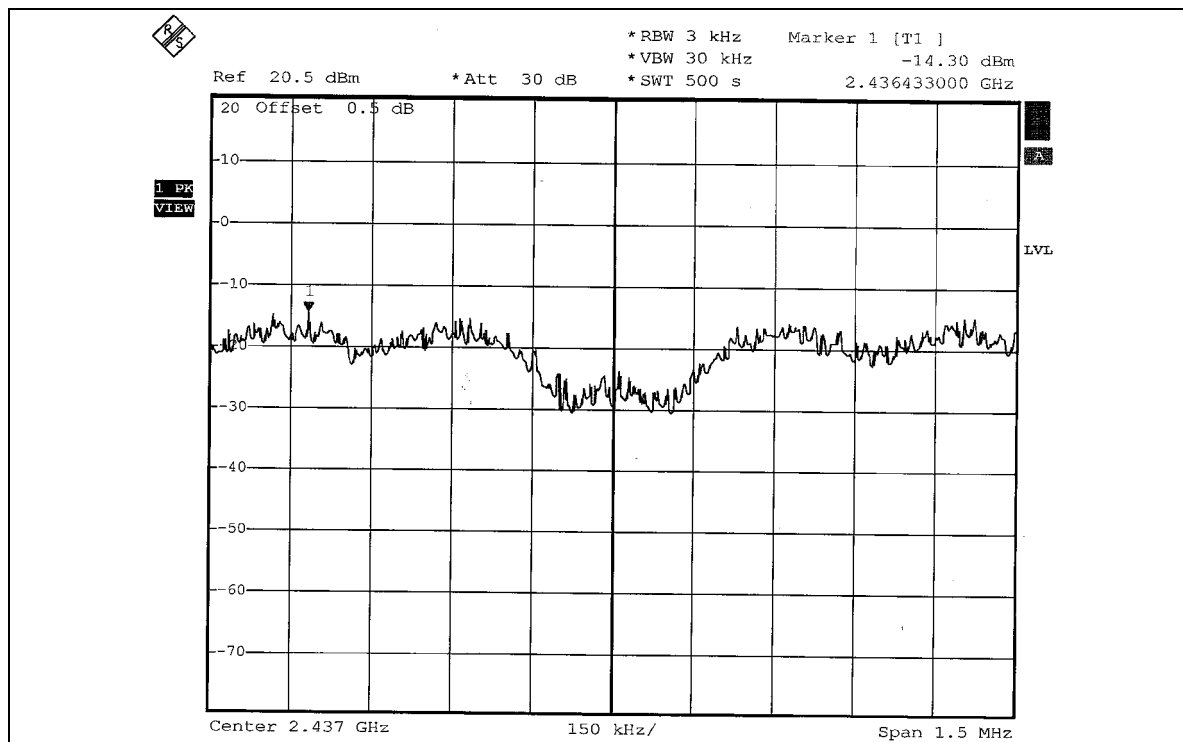



CH11

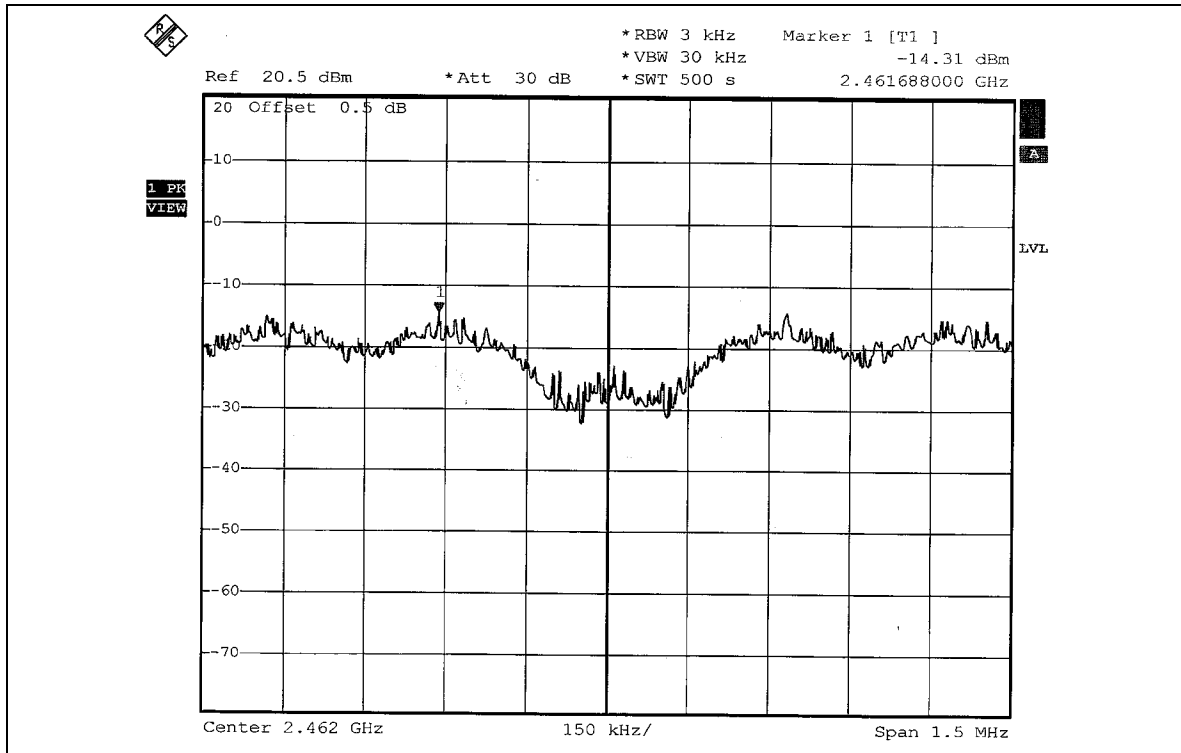



4.6 BAND EDGES MEASUREMENT

4.6.1 LIMITS OF BAND EDGES MEASUREMENT

Below -20dB of the highest emission level of operating band (in 100kHz Resolution Bandwidth).

4.6.2 TEST INSTRUMENTS

DESCRIPTION & MANUFACTURER	MODEL NO.	SERIAL NO.	CALIBRATED UNTIL
SPECTRUM ANALYZER	FSEK30	100049	Aug. 14, 2006

NOTE: The calibration interval of the above test instruments is 12 months and the calibrations are traceable to NML/ROC and NIST/USA.

4.6.3 TEST PROCEDURE

The transmitter output was connected to the spectrum analyzer via a low lose cable. Set both RBW and VBW of spectrum analyzer to 100kHz with suitable frequency span including 100MHz bandwidth from band edge. The band edges was measured and recorded.

The spectrum plots (Peak RBW=VBW=100kHz; Average RBW=1MHz, VBW=10kHz) are attached on the following pages.

4.6.4 DEVIATION FROM TEST STANDARD

No deviation

4.6.5 EUT OPERATING CONDITION

Same as Item 4.3.6



4.6.6 TEST RESULTS

The spectrum plots are attached on the following 18 images. D1 line indicates the highest level, and D2 line indicates the 20dB offset below D1. It shows compliance with the requirement in part 15.247(d).

802.11b DSSS MODULATION

NOTE 1: The band edge emission plot on page 55 shows 48.94dBc between carrier maximum power and local maximum emission in restrict band (2.3852GHz). The emission of carrier strength list in the test result of channel 1 at the item 4.2.7 is 106.94dBuV/m (Peak), so the maximum field strength in restrict band is $106.94 - 48.94 = 58.00$ dBuV/m, which is under 74dBuV/m limit.

The band edge emission plot on page 55 shows 51.65dBc between carrier maximum power and local maximum emission in restrict band (2.3858GHz). The emission of carrier strength list in the test result of channel 1 at the item 4.2.7 is 103.14dBuV/m (Average), so the maximum field strength in restrict band is $103.14 - 51.65 = 51.49$ dBuV/m, which is under 54dBuV/m limit.

NOTE 2: The band edge emission plot on page 56 shows 50.82dBc between carrier maximum power and local maximum emission in restrict band (2.4878GHz). The emission of carrier strength list in the test result of channel 11 at the item 4.2.7 is 108.53dBuV/m (Peak), so the maximum field strength in restrict band is $108.53 - 50.82 = 57.71$ dBuV/m, which is under 74dBuV/m limit.

The band edge emission plot on page 57 shows 53.74dBc between carrier maximum power and local maximum emission in restrict band (2.4878GHz). The emission of carrier strength list in the test result of channel 11 at the item 4.2.7 is 104.69dBuV/m (Average), so the maximum field strength in restrict band is $104.69 - 53.74 = 50.95$ dBuV/m, which is under 54dBuV/m limit.

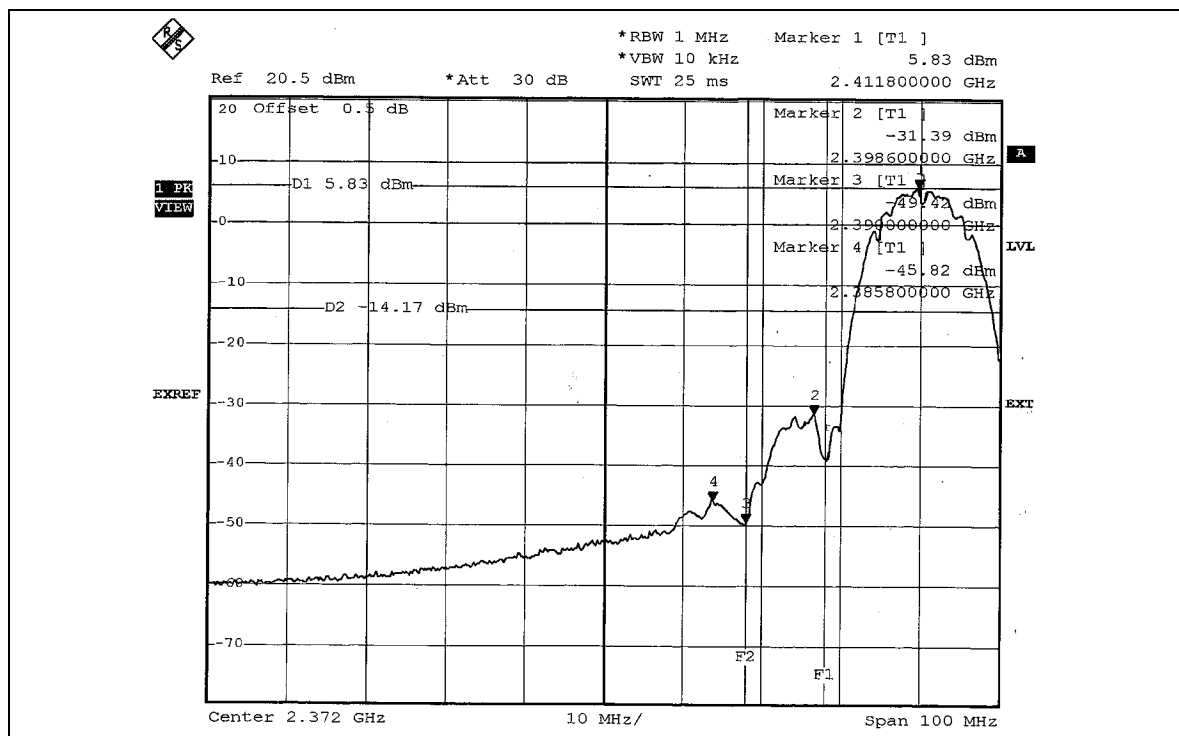
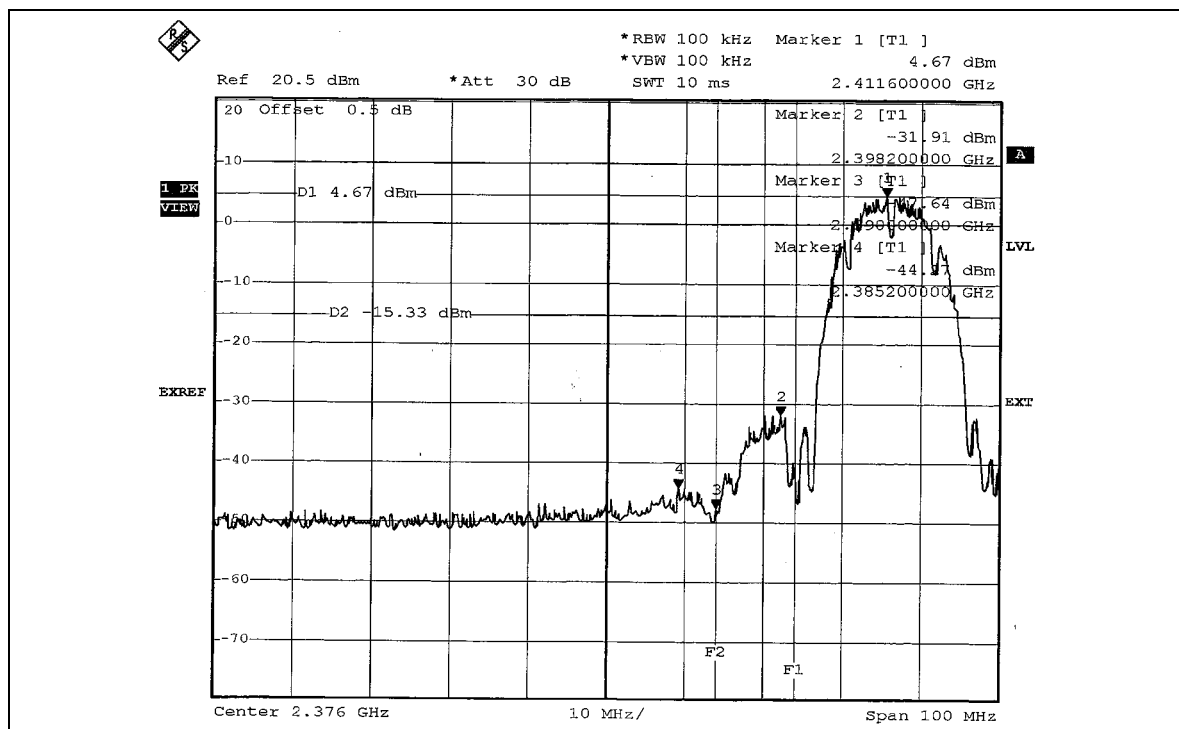

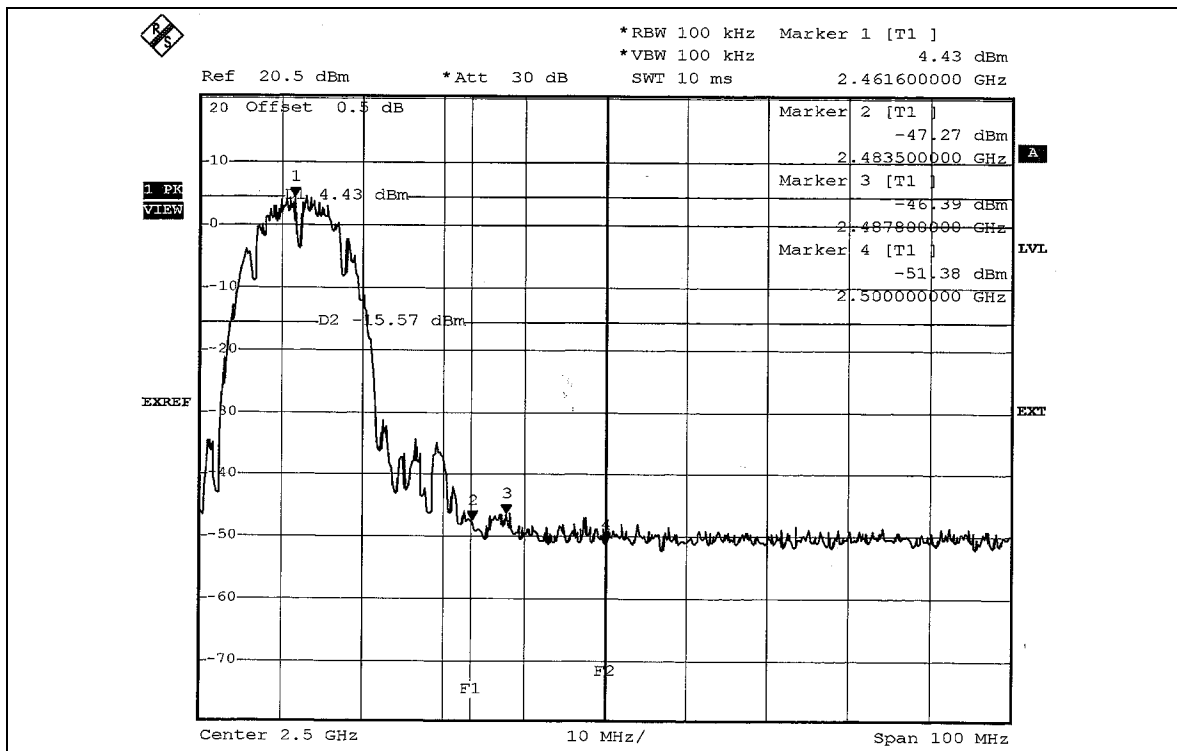
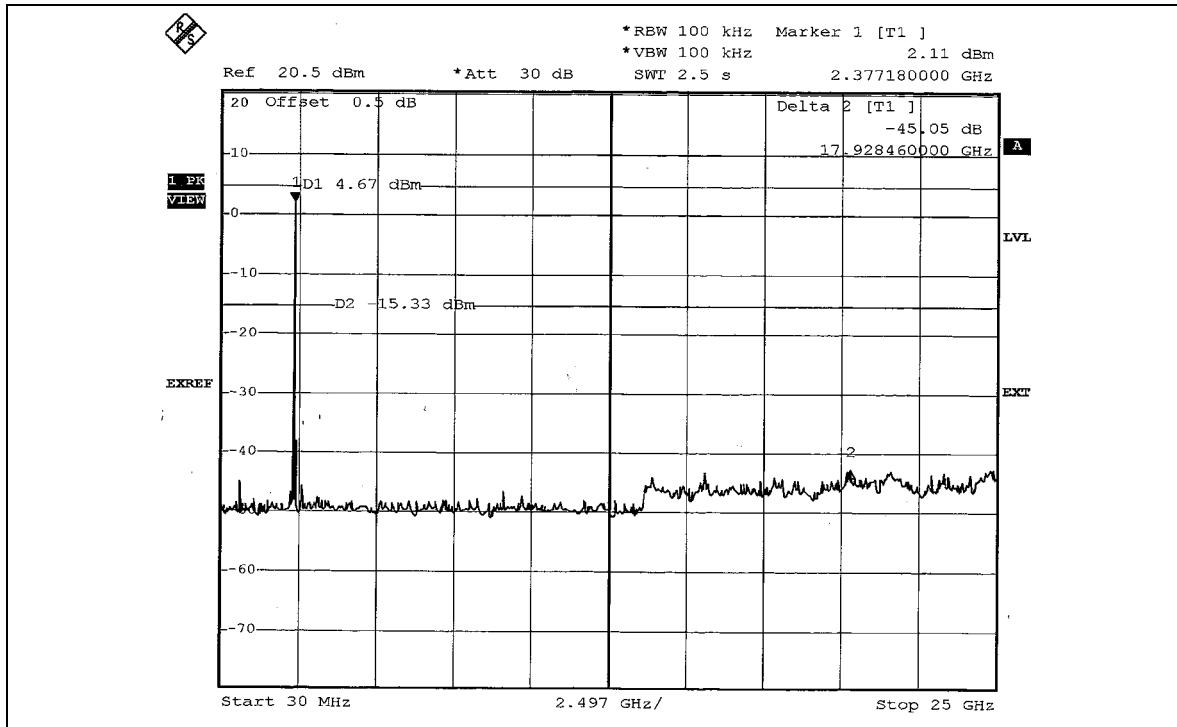

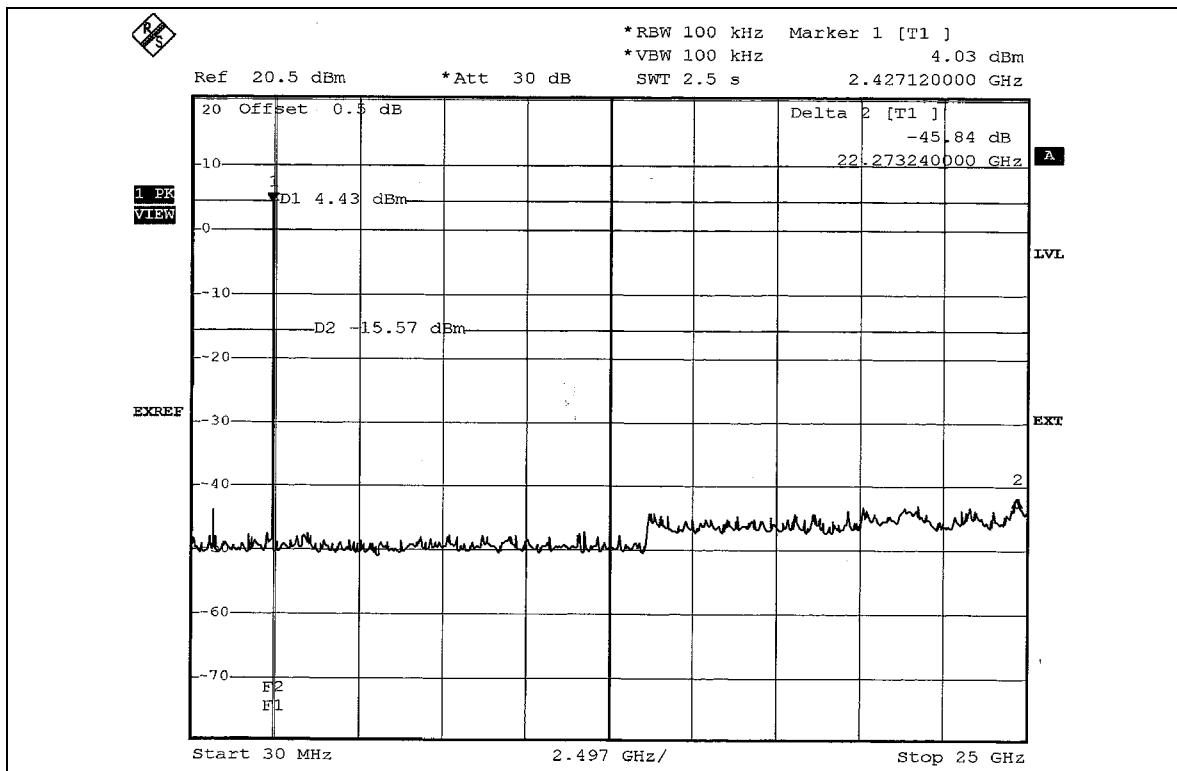
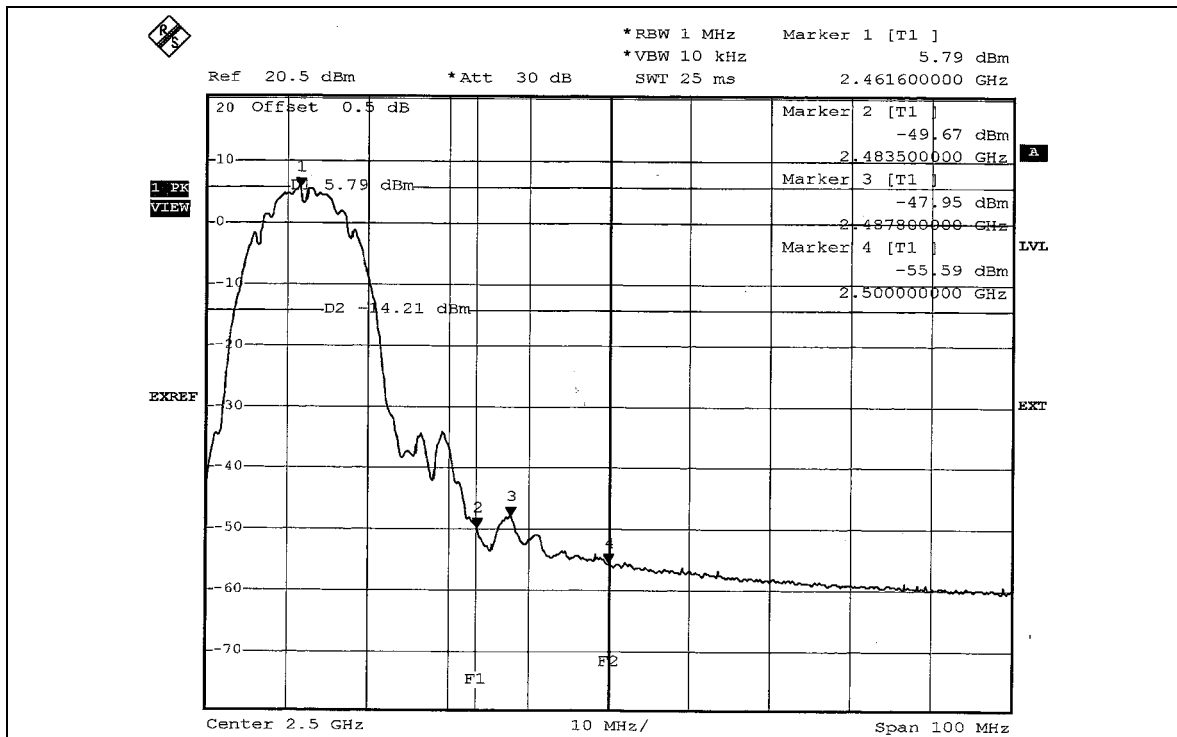



802.11g OFDM MODULATION

NOTE 1: The band edge emission plot on page 59 shows 44.38dBc between carrier maximum power and local maximum emission in restrict band (2.38496GHz). The emission of carrier strength list in the test result of channel 1 at the item 4.2.7 is 107.58dBuV/m (Peak), so the maximum field strength in restrict band is $107.58 - 44.38 = 63.20$ dBuV/m, which is under 74dBuV/m limit.

The band edge emission plot on page 59 shows 45.49dBc between carrier maximum power and local maximum emission in restrict band (2.3900GHz). The emission of carrier strength list in the test result of channel 1 at the item 4.2.7 is 98.20dBuV/m (Average), so the maximum field strength in restrict band is $98.20 - 45.49 = 52.71$ dBuV/m, which is under 54dBuV/m limit.

NOTE 2: The band edge emission plot on page 60 shows 46.48dBc between carrier maximum power and local maximum emission in restrict band (2.4835GHz). The emission of carrier strength list in the test result of channel 11 at the item 4.2.7 is 108.55dBuV/m (Peak), so the maximum field strength in restrict band is $108.55 - 46.48 = 62.07$ dBuV/m, which is under 74dBuV/m limit.

The band edge emission plot on page 61 shows 46.97dBc between carrier maximum power and local maximum emission in restrict band (2.4835GHz). The emission of carrier strength list in the test result of channel 11 at the item 4.2.7 is 99.30dBuV/m (Average), so the maximum field strength in restrict band is $99.30 - 46.97 = 52.33$ dBuV/m, which is under 54dBuV/m limit.

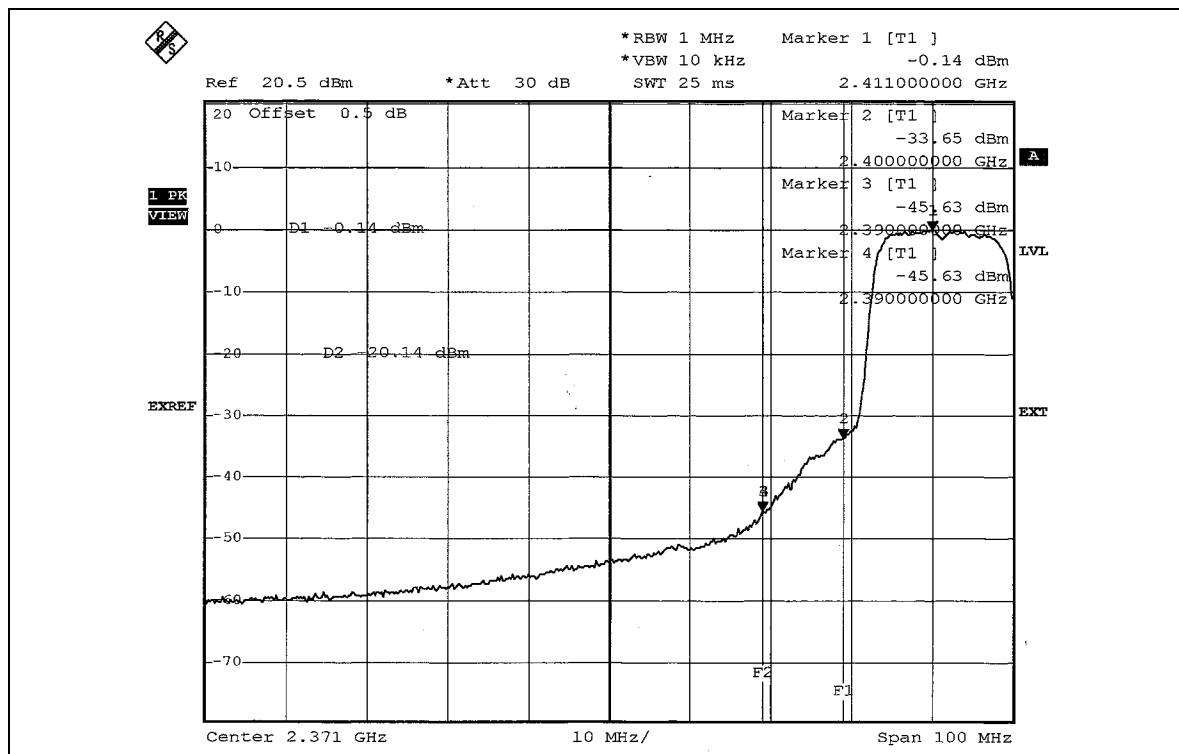
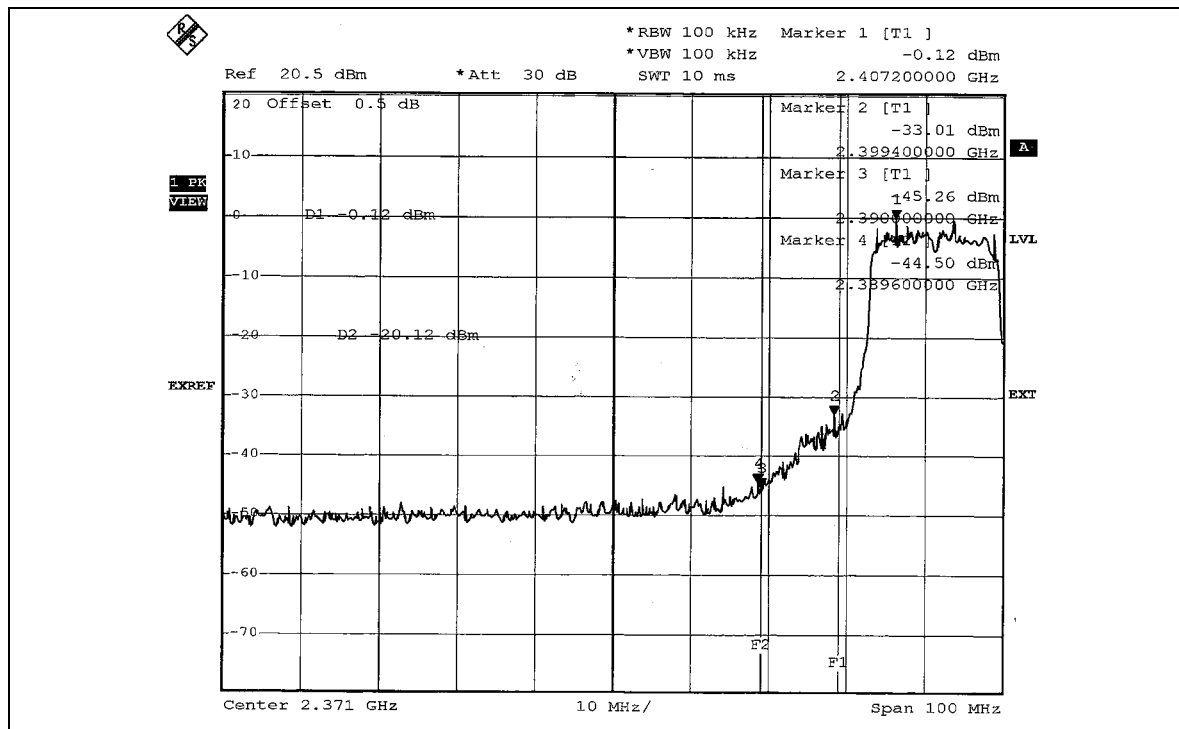

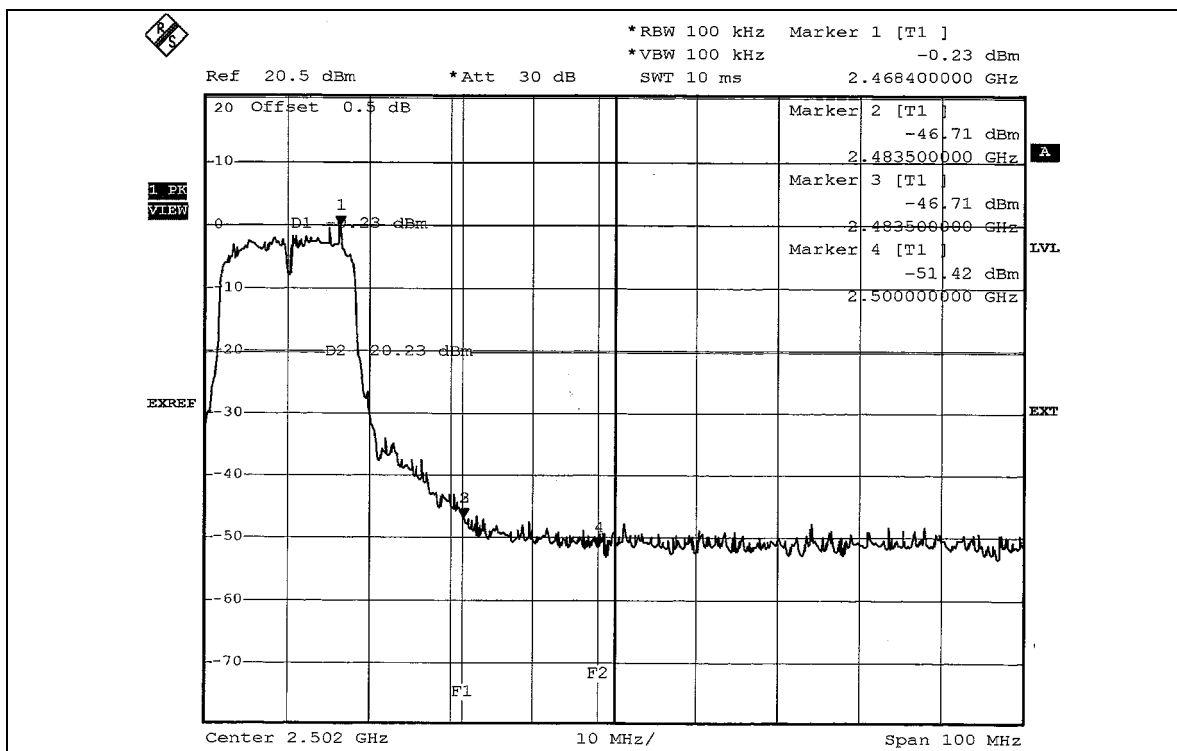
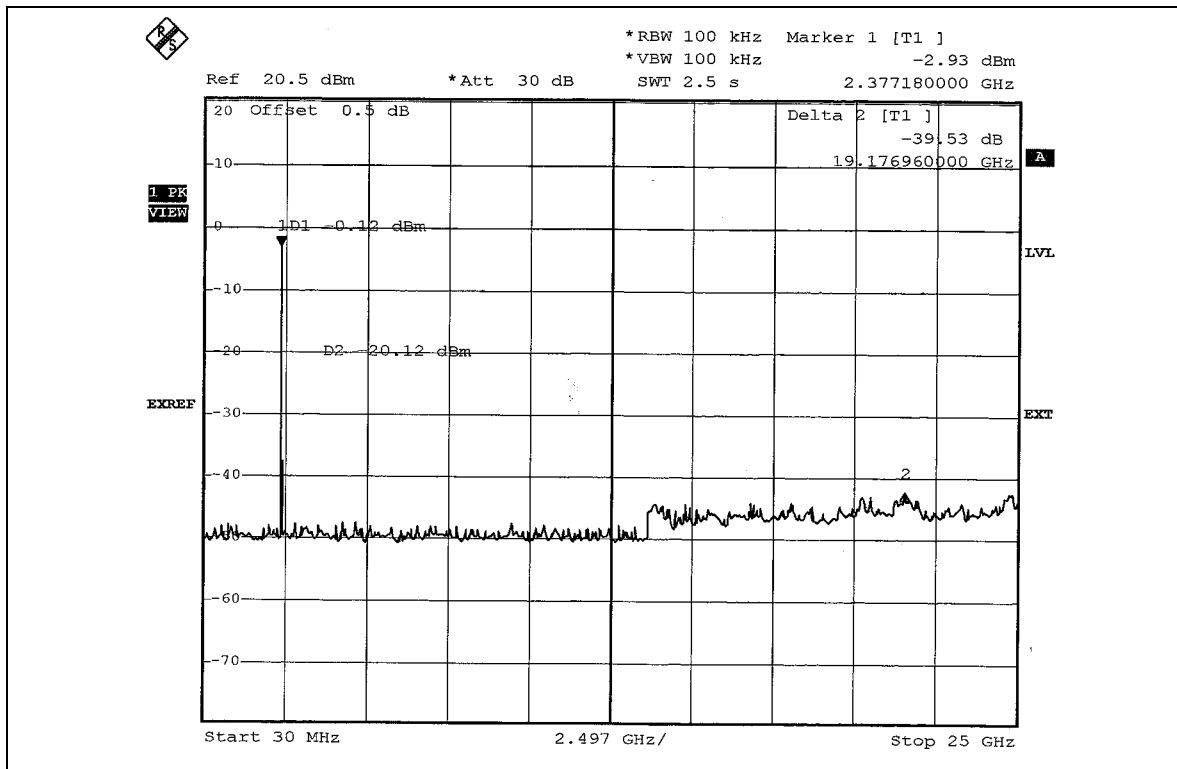

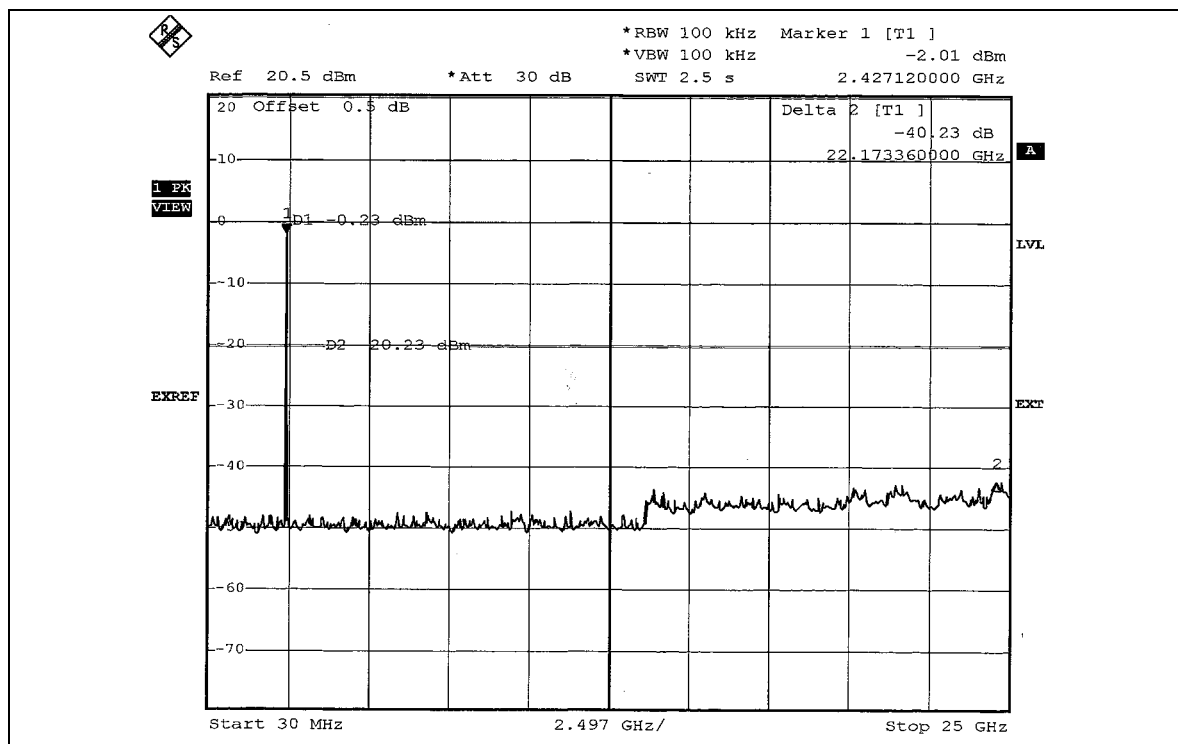
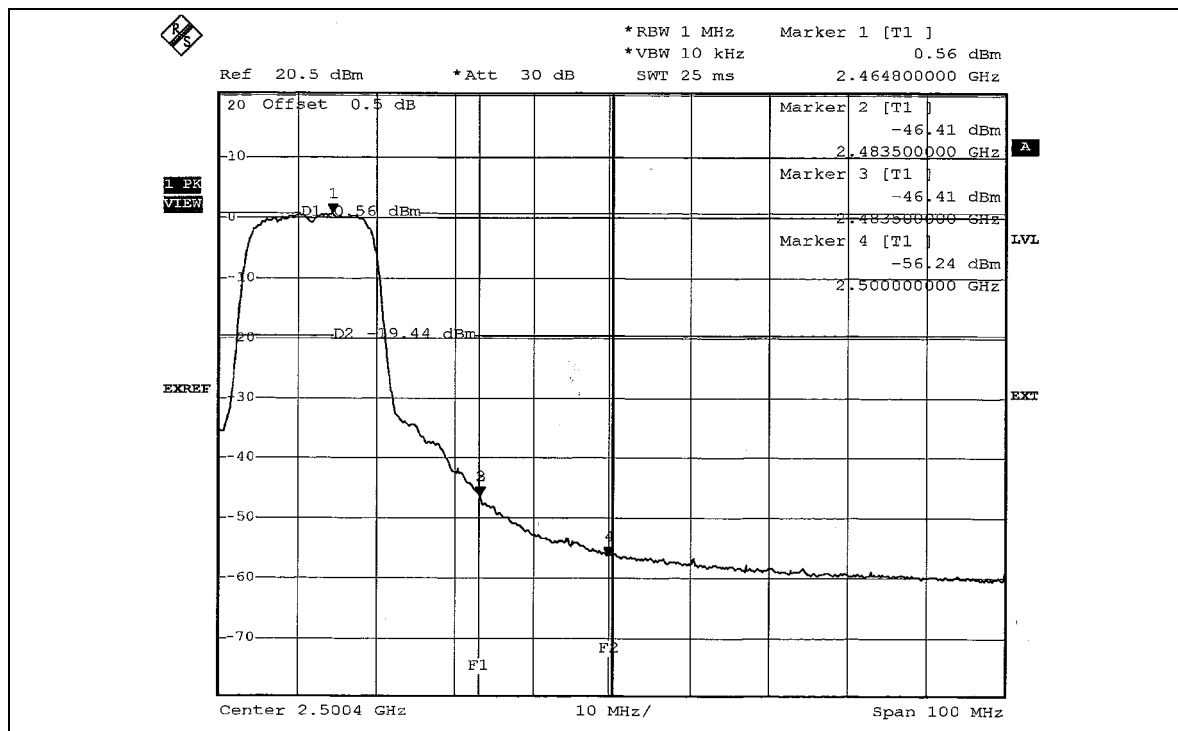



5. TEST TYPES AND RESULTS (For Dual CHAIN (TX))

5.1 CONDUCTED EMISSION MEASUREMENT

5.1.1 LIMITS OF CONDUCTED EMISSION MEASUREMENT

FREQUENCY OF EMISSION (MHz)	CONDUCTED LIMIT (dB μ V)	
	Quasi-peak	Average
0.15 ~ 0.5	66 to 56	56 to 46
0.5 ~ 5	56	46
5 ~ 30	60	50

- NOTE:**
1. The lower limit shall apply at the transition frequencies.
 2. The limit decreases in line with the logarithm of the frequency in the range of 0.15 to 0.50 MHz.
 3. All emanations from a class A/B digital device or system, including any network of conductors and apparatus connected thereto, shall not exceed the level of field strengths specified above.

5.1.2 TEST INSTRUMENTS

DESCRIPTION & MANUFACTURER	MODEL NO.	SERIAL NO.	CALIBRATED UNTIL
Test Receiver ROHDE & SCHWARZ	ESCS30	100288	Nov. 02, 2006
RF signal cable Woken	5D-FB	Cable-HyC02-01	Jan. 09, 2006
LISN ROHDE & SCHWARZ	ESH2-Z5	100100	Jan. 20, 2006
LISN ROHDE & SCHWARZ	ESH3-Z5	100311	Jan. 20, 2006
Software ADT	ADT_Cond_V3	NA	NA

- NOTE:**
1. The calibration interval of the above test instruments is 12 months and the calibrations are traceable to NML/ROC and NIST/USA.
 2. The test was performed in HwaYa Shielded Room 3.
 3. The VCCI Site Registration No. is C-2047.



5.1.3 TEST PROCEDURES

- a. The EUT was placed 0.4 meters from the conducting wall of the shielded room with EUT being connected to the power mains through a line impedance stabilization network (LISN). Other support units were connected to the power mains through another LISN. The two LISNs provide 50 ohm/ 50uH of coupling impedance for the measuring instrument.
- b. Both lines of the power mains connected to the EUT were checked for maximum conducted interference.
- c. The frequency range from 150kHz to 30MHz was searched. Emission levels under Limit - 20dB was not recorded.

5.1.4 DEVIATION FROM TEST STANDARD

No deviation

5.1.5 TEST SETUP

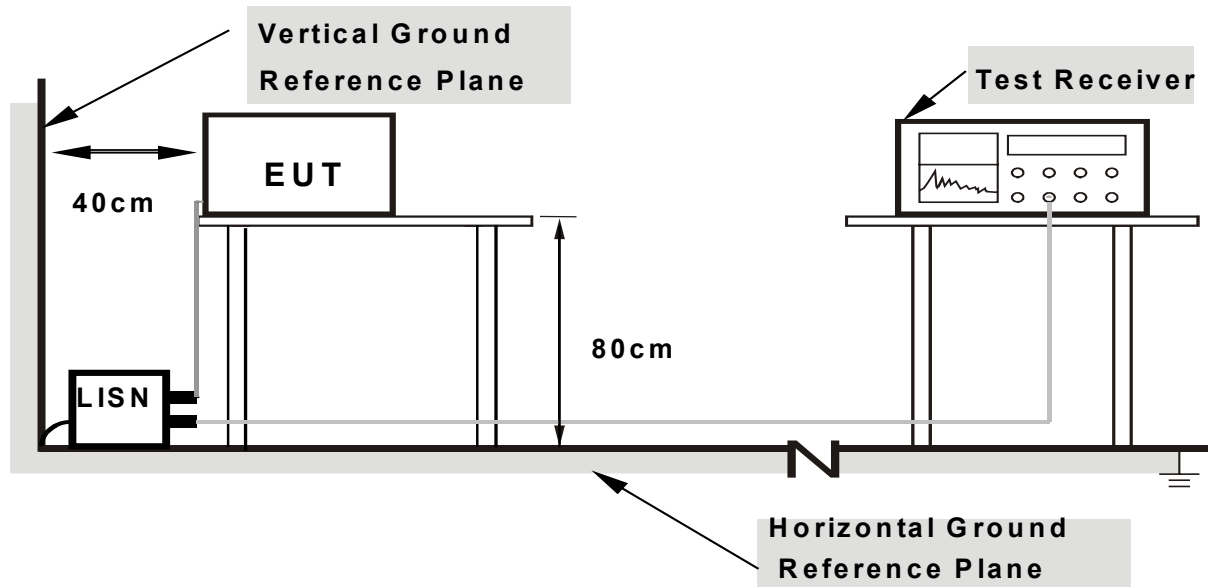

- Note:**
- 1.Support units were connected to second LISN.
 - 2.Both of LISNs (AMN) are 80 cm from EUT and at least 80 from other units and other metal planes

For the actual test configuration, please refer to the related item – Photographs of the Test Configuration.

5.1.6 EUT OPERATING CONDITIONS

Same as 4.1.6



5.1.7 TEST RESULTS

CONDUCTED WORST CASE DATA

EUT	ADSL Modem with Wireless Pre-N Router	MEASUREMENT DETAIL	
MODEL	F5D8630-4	PHASE	Line 1
CHANNEL	Channel 1	6dB BANDWIDTH	9 kHz
MODULATION TYPE	BPSK	ENVIRONMENTAL CONDITIONS	25deg. C, 65%RH, 991hPa
TRANSFER RATE	36Mbps	INPUT POWER (SYSTEM)	120Vac, 60 Hz
TESTED BY	Jay Hsu		

No	Freq. [MHz]	Corr. Factor (dB)	Reading Value		Emission Level		Limit		Margin	
			[dB (uV)]		[dB (uV)]		[dB (uV)]		(dB)	
			Q.P.	AV.	Q.P.	AV.	Q.P.	AV.	Q.P.	AV.
1	0.154	0.11	40.04	-	40.15	-	65.79	55.79	-25.64	-
2	0.974	0.23	40.92	-	41.15	-	56.00	46.00	-14.85	-
3	1.332	0.24	45.28	-	45.52	-	56.00	46.00	-10.48	-
4	2.484	0.26	40.59	-	40.85	-	56.00	46.00	-15.15	-
5	3.770	0.29	43.19	-	43.48	-	56.00	46.00	-12.52	-
6	17.694	0.78	35.01	-	35.79	-	60.00	50.00	-24.21	-

- REMARKS:**
1. Q.P. and AV. are abbreviations of quasi-peak and average individually.
 2. "-": The Quasi-peak reading value also meets average limit and measurement with the average detector is unnecessary.
 3. The emission levels of other frequencies were very low against the limit.
 4. Margin value = Emission level - Limit value
 5. Correction factor = Insertion loss + Cable loss
 6. Emission Level = Correction Factor + Reading Value.

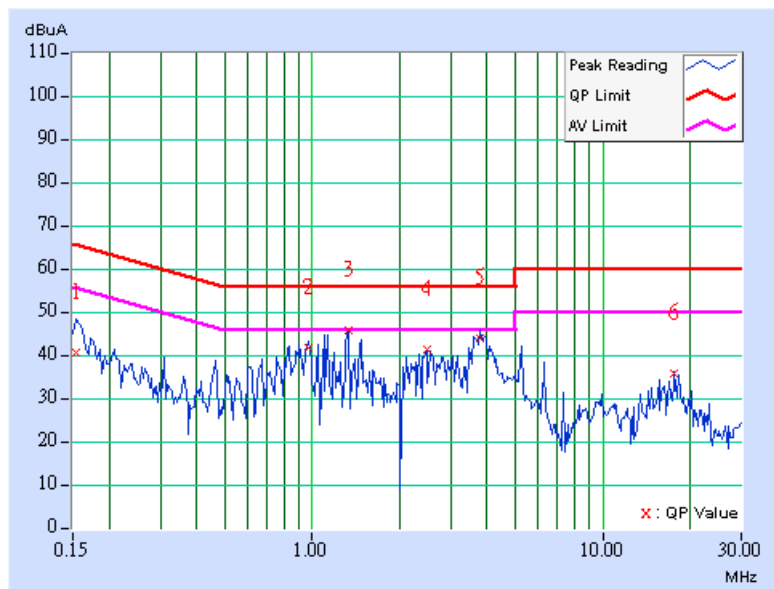



EUT	ADSL Modem with Wireless Pre-N Router	MEASUREMENT DETAIL	
MODEL	F5D8630-4	PHASE	Line 2
CHANNEL	Channel 1	6dB BANDWIDTH	9 kHz
MODULATION TYPE	BPSK	ENVIRONMENTAL CONDITIONS	25deg. C, 65%RH, 991hPa
TRANSFER RATE	36Mbps	INPUT POWER (SYSTEM)	120Vac, 60 Hz
TESTED BY	Jay Hsu		

No	Freq. [MHz]	Corr. Factor (dB)	Reading Value [dB (uV)]		Emission Level [dB (uV)]		Limit [dB (uV)]		Margin (dB)	
			Q.P.	AV.	Q.P.	AV.	Q.P.	AV.	Q.P.	AV.
			1	0.162	0.11	37.00	-	37.11	-	65.38
2	0.974	0.23	40.58	-	40.81	-	56.00	46.00	-15.19	-
3	1.266	0.24	44.17	-	44.41	-	56.00	46.00	-11.59	-
4	2.406	0.26	39.42	-	39.68	-	56.00	46.00	-16.32	-
5	3.691	0.28	44.53	-	44.81	-	56.00	46.00	-11.19	-
6	17.693	0.83	35.21	-	36.04	-	60.00	50.00	-23.96	-

- REMARKS:**
1. Q.P. and AV. are abbreviations of quasi-peak and average individually.
 2. "-": The Quasi-peak reading value also meets average limit and measurement with the average detector is unnecessary.
 3. The emission levels of other frequencies were very low against the limit.
 4. Margin value = Emission level - Limit value
 5. Correction factor = Insertion loss + Cable loss
 6. Emission Level = Correction Factor + Reading Value.

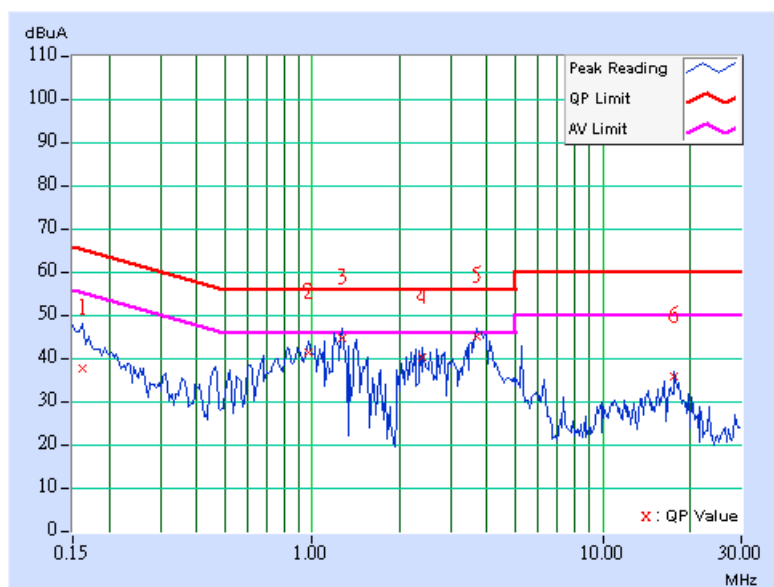



EUT	ADSL Modem with Wireless Pre-N Router	MEASUREMENT DETAIL	
MODEL	F5D8630-4	PHASE	Line 1
CHANNEL	Channel 6	6dB BANDWIDTH	9 kHz
MODULATION TYPE	BPSK	ENVIRONMENTAL CONDITIONS	25deg. C, 65%RH, 991hPa
TRANSFER RATE	36Mbps	INPUT POWER (SYSTEM)	120Vac, 60 Hz
TESTED BY	Jay Hsu		

No	Freq. [MHz]	Corr. Factor (dB)	Reading Value [dB (uV)]		Emission Level [dB (uV)]		Limit [dB (uV)]		Margin (dB)	
			Q.P.	AV.	Q.P.	AV.	Q.P.	AV.	Q.P.	AV.
			1	0.158	0.11	38.80	-	38.91	-	65.58
2	0.826	0.20	40.16	-	40.36	-	56.00	46.00	-15.64	-
3	1.246	0.23	41.63	-	41.86	-	56.00	46.00	-14.14	-
4	2.480	0.26	39.29	-	39.55	-	56.00	46.00	-16.45	-
5	3.695	0.28	43.63	-	43.91	-	56.00	46.00	-12.09	-
6	17.693	0.78	35.23	-	36.01	-	60.00	50.00	-23.99	-

- REMARKS:**
1. Q.P. and AV. are abbreviations of quasi-peak and average individually.
 2. "-": The Quasi-peak reading value also meets average limit and measurement with the average detector is unnecessary.
 3. The emission levels of other frequencies were very low against the limit.
 4. Margin value = Emission level - Limit value
 5. Correction factor = Insertion loss + Cable loss
 6. Emission Level = Correction Factor + Reading Value.

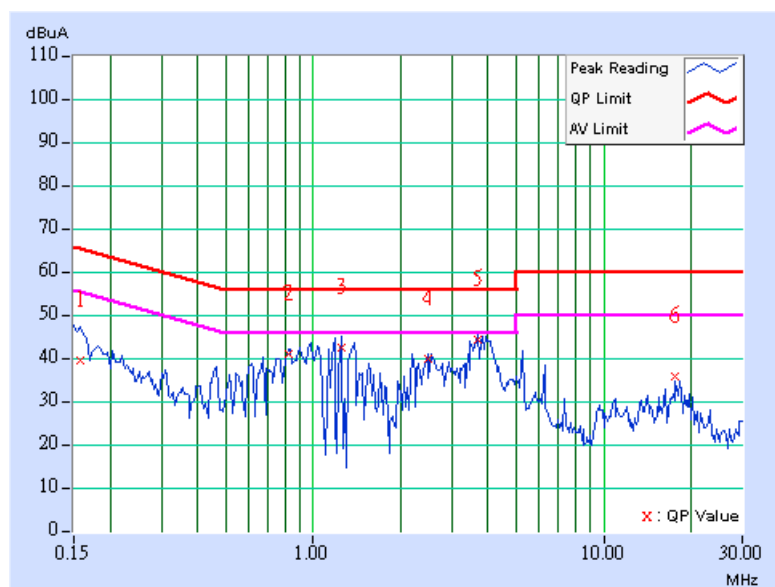



EUT	ADSL Modem with Wireless Pre-N Router	MEASUREMENT DETAIL	
MODEL	F5D8630-4	PHASE	Line 2
CHANNEL	Channel 6	6dB BANDWIDTH	9 kHz
MODULATION TYPE	BPSK	ENVIRONMENTAL CONDITIONS	25deg. C, 65%RH, 991hPa
TRANSFER RATE	36Mbps	INPUT POWER (SYSTEM)	120Vac, 60 Hz
TESTED BY	Jay Hsu		

No	Freq. [MHz]	Corr. Factor (dB)	Reading Value		Emission Level		Limit		Margin	
			[dB (uV)]		[dB (uV)]		[dB (uV)]		(dB)	
			Q.P.	AV.	Q.P.	AV.	Q.P.	AV.	Q.P.	AV.
1	0.156	0.11	39.48	-	39.59	-	65.70	55.70	-26.11	-
2	0.831	0.20	40.06	-	40.26	-	56.00	46.00	-15.74	-
3	1.184	0.23	43.79	-	44.02	-	56.00	46.00	-11.98	-
4	2.340	0.26	40.30	-	40.56	-	56.00	46.00	-15.44	-
5	3.852	0.29	42.95	-	43.24	-	56.00	46.00	-12.76	-
6	17.693	0.83	35.12	-	35.95	-	60.00	50.00	-24.05	-

- REMARKS:**
1. Q.P. and AV. are abbreviations of quasi-peak and average individually.
 2. "-": The Quasi-peak reading value also meets average limit and measurement with the average detector is unnecessary.
 3. The emission levels of other frequencies were very low against the limit.
 4. Margin value = Emission level - Limit value
 5. Correction factor = Insertion loss + Cable loss
 6. Emission Level = Correction Factor + Reading Value.

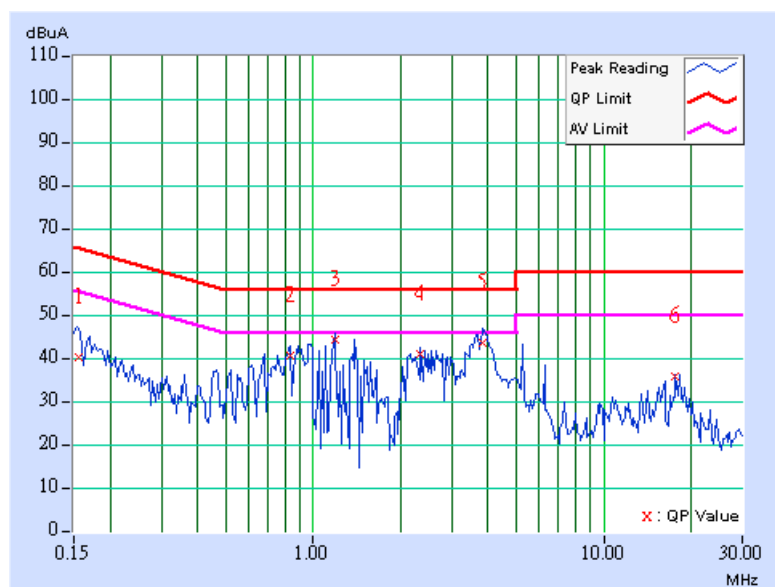



EUT	ADSL Modem with Wireless Pre-N Router	MEASUREMENT DETAIL	
MODEL	F5D8630-4	PHASE	Line 1
CHANNEL	Channel 11	6dB BANDWIDTH	9 kHz
MODULATION TYPE	BPSK	ENVIRONMENTAL CONDITIONS	25deg. C, 65%RH, 991hPa
TRANSFER RATE	36Mbps	INPUT POWER (SYSTEM)	120Vac, 60 Hz
TESTED BY	Jay Hsu		

No	Freq. [MHz]	Corr. Factor (dB)	Reading Value		Emission Level		Limit		Margin	
			[dB (uV)]		[dB (uV)]		[dB (uV)]		(dB)	
			Q.P.	AV.	Q.P.	AV.	Q.P.	AV.	Q.P.	AV.
1	0.154	0.11	39.78	-	39.89	-	65.79	55.79	-25.90	-
2	0.822	0.20	40.00	-	40.20	-	56.00	46.00	-15.80	-
3	1.258	0.24	43.89	-	44.13	-	56.00	46.00	-11.87	-
4	2.117	0.25	38.91	-	39.16	-	56.00	46.00	-16.84	-
5	3.770	0.29	44.13	-	44.42	-	56.00	46.00	-11.58	-
6	17.694	0.78	34.86	-	35.64	-	60.00	50.00	-24.36	-

- REMARKS:**
1. Q.P. and AV. are abbreviations of quasi-peak and average individually.
 2. "-": The Quasi-peak reading value also meets average limit and measurement with the average detector is unnecessary.
 3. The emission levels of other frequencies were very low against the limit.
 4. Margin value = Emission level - Limit value
 5. Correction factor = Insertion loss + Cable loss
 6. Emission Level = Correction Factor + Reading Value.

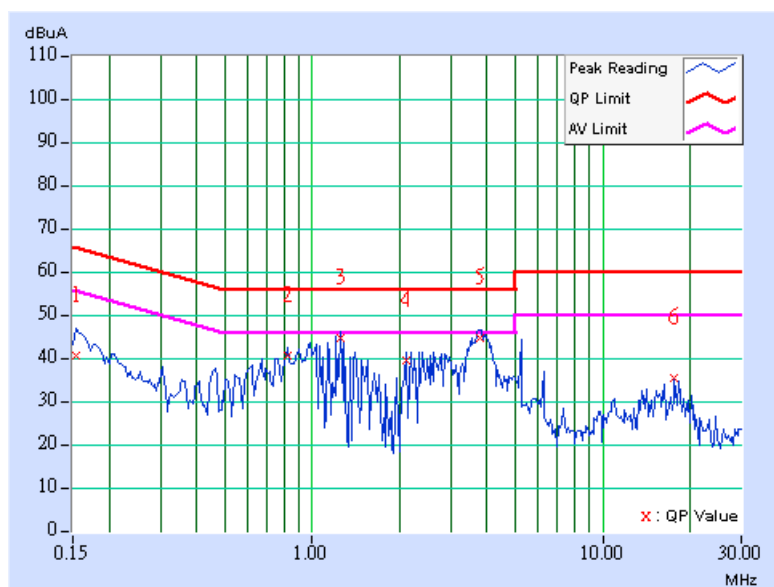



EUT	ADSL Modem with Wireless Pre-N Router	MEASUREMENT DETAIL	
MODEL	F5D8630-4	PHASE	Line 2
CHANNEL	Channel 11	6dB BANDWIDTH	9 kHz
MODULATION TYPE	BPSK	ENVIRONMENTAL CONDITIONS	25deg. C, 65%RH, 991hPa
TRANSFER RATE	36Mbps	INPUT POWER (SYSTEM)	120Vac, 60 Hz
TESTED BY	Jay Hsu		

No	Freq. [MHz]	Corr. Factor (dB)	Reading Value [dB (uV)]		Emission Level [dB (uV)]		Limit [dB (uV)]		Margin (dB)	
			Q.P.	AV.	Q.P.	AV.	Q.P.	AV.	Q.P.	AV.
			1	0.152	0.11	40.22	-	40.33	-	65.91
2	0.978	0.23	40.96	-	41.19	-	56.00	46.00	-14.81	-
3	1.332	0.24	45.22	-	45.46	-	56.00	46.00	-10.54	-
4	2.258	0.26	38.65	-	38.91	-	56.00	46.00	-17.09	-
5	3.766	0.29	42.84	-	43.13	-	56.00	46.00	-12.87	-
6	18.243	0.86	34.61	-	35.47	-	60.00	50.00	-24.53	-

- REMARKS:**
1. Q.P. and AV. are abbreviations of quasi-peak and average individually.
 2. "-": The Quasi-peak reading value also meets average limit and measurement with the average detector is unnecessary.
 3. The emission levels of other frequencies were very low against the limit.
 4. Margin value = Emission level - Limit value
 5. Correction factor = Insertion loss + Cable loss
 6. Emission Level = Correction Factor + Reading Value.

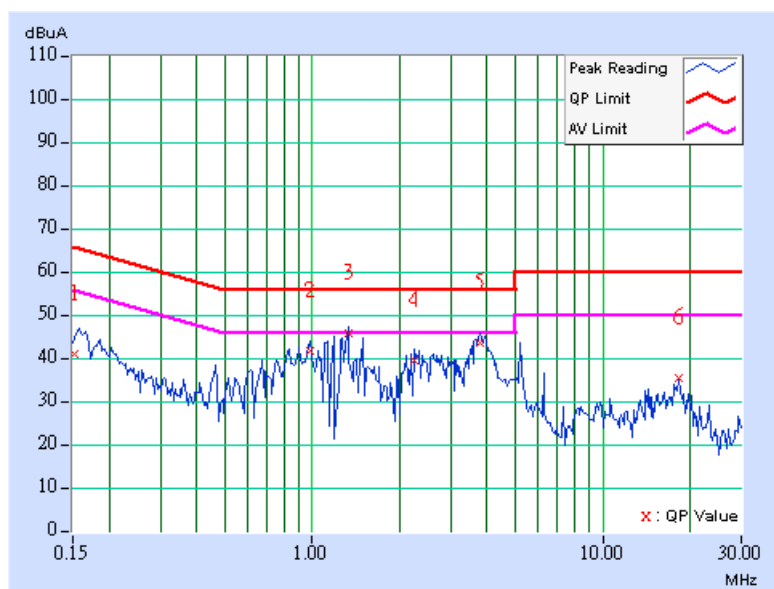



5.2 RADIATED EMISSION MEASUREMENT

5.2.1 LIMITS OF RADIATED EMISSION MEASUREMENT

Emissions radiated outside of the specified bands, shall be according to the general radiated limits in 15.209 as following:

FREQUENCIES (MHz)	FIELD STRENGTH (microvolts/meter)	MEASUREMENT DISTANCE (meters)
0.009-0.490	2400/F(kHz)	300
0.490-1.705	24000/F(kHz)	30
1.705-30.0	30	30
30-88	100	3
88-216	150	3
216-960	200	3
Above 960	500	3

NOTE:

1. The lower limit shall apply at the transition frequencies.
2. Emission level (dBuV/m) = 20 log Emission level (uV/m).
3. As shown in 15.35(b), for frequencies above 1000MHz, the field strength limits are based on average detector, however, the peak field strength of any emission shall not exceed the maximum permitted average limits, specified above by more than 20dB under any condition of modulation.



5.2.2 TEST INSTRUMENTS

DESCRIPTION & MANUFACTURER	MODEL NO.	SERIAL NO.	CALIBRATED UNTIL
Test Receiver ROHDE & SCHWARZ	ESI7	838496/016	Jan. 07, 2006
Spectrum Analyzer ROHDE & SCHWARZ	FSP40	100041	Nov. 29, 2005
BILOG Antenna SCHWARZBECK	VULB9168	9168-155	Jan. 22, 2006
HORN Antenna SCHWARZBECK	BBHA 9120D	9120D-404	Jan. 05, 2006
HORN Antenna SCHWARZBECK	BBHA 9170	BBHA 9170242	Jan. 23, 2006
Preamplifier Agilent	8449B	3008A01960	Nov. 09, 2006
RF signal cable HUBER+SUHNNER	SUCOFLEX 104	219272/4	Jan. 26, 2006
RF signal cable HUBER+SUHNNER	SUCOFLEX 104	219275/4	Jan. 26, 2006
Software ADT.	ADT_Radiated_V5.14	NA	NA
Antenna Tower inn-co GmbH	MA 4000	010303	NA
Antenna Tower Controller inn-co GmbH	CO2000	019303	NA
Turn Table ADT.	TT100.	TT93021704	NA
Turn Table Controller ADT.	SC100.	SC93021704	NA

- NOTE:**
1. The calibration interval of the above test instruments is 12 months and the calibrations are traceable to NML/ROC and NIST/USA.
 2. The test was performed in HwaYa Chamber 3.
 3. The horn antenna and HP preamplifier (model: 8449B) are used only for the measurement of emission frequency above 1GHz if tested.
 4. The IC Site Registration No. is IC4924-4.



5.2.3 TEST PROCEDURES

- a. The EUT was placed on the top of a rotating table 0.8 meters above the ground at a 3 meter semi-anechoic chamber. The table was rotated 360 degrees to determine the position of the highest radiation.
- b. The EUT was set 3 meters away from the interference-receiving antenna, which was mounted on the top of a variable-height antenna tower.
- c. The antenna is a broadband antenna, and its height is varied from one meter to four meters above the ground to determine the maximum value of the field strength. Both horizontal and vertical polarizations of the antenna are set to make the measurement.
- d. For each suspected emission, the EUT was arranged to its worst case and then the antenna was tuned to heights from 1 meter to 4 meters and the rotatable table was turned from 0 degrees to 360 degrees to find the maximum reading.
- e. The test-receiver system was set to Peak Detect Function and Specified Bandwidth with Maximum Hold Mode.
- f. If the emission level of the EUT in peak mode was 10 dB lower than the limit specified, then testing could be stopped and the peak values of the EUT would be reported. Otherwise the emissions that did not have 10 dB margin would be re-tested one by one using peak, quasi-peak or average method as specified and then reported in a data sheet.

NOTE:

1. The resolution bandwidth and video bandwidth of test receiver/spectrum analyzer is 120kHz for Peak detection (PK) and Quasi-peak detection (QP) at frequency below 1GHz.
2. The resolution bandwidth and video bandwidth of test receiver/spectrum analyzer is 1 MHz for Peak detection at frequency above 1GHz.
3. The resolution bandwidth of test receiver/spectrum analyzer is 1 MHz and the video bandwidth is 10kHz for Average detection (AV) at frequency above 1GHz.

5.2.4 DEVIATION FROM TEST STANDARD

No deviation

5.2.5 TEST SETUP

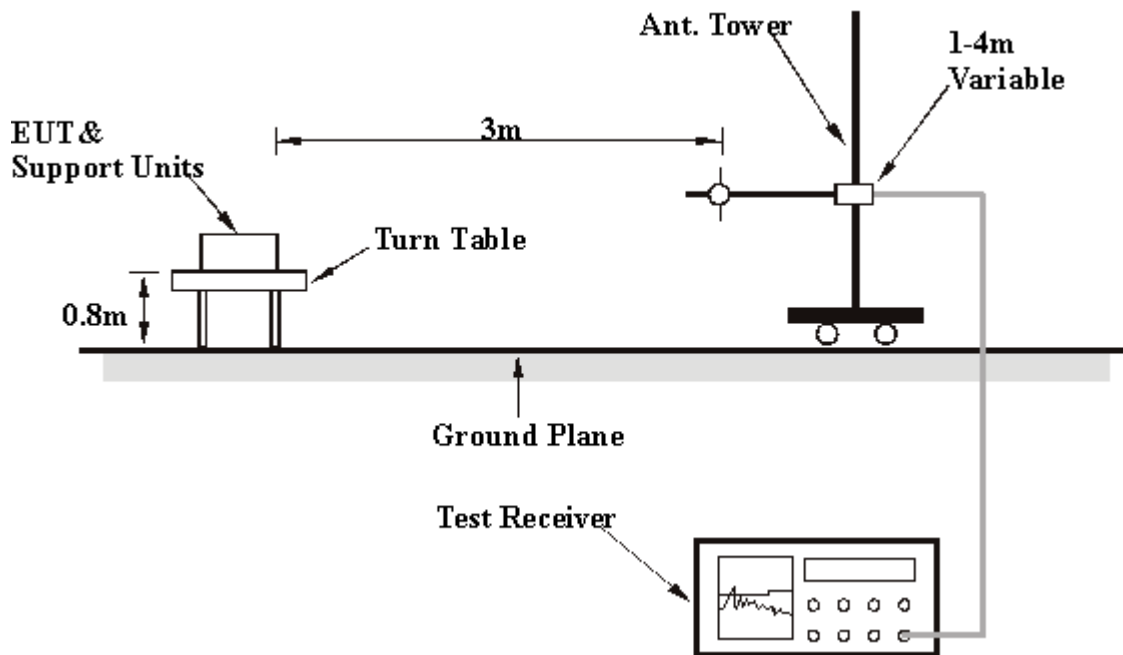

For the actual test configuration, please refer to the related item – Photographs of the Test Configuration.

5.2.6 EUT OPERATING CONDITIONS

For finding the maximum radiated emission under this dual chain operation mode. The beam-forming coefficients has been adjusted to swing 30 degrees each step and pre-scans reveal that the maximum radiated emission is independent of the beam-forming coefficients, and hence the all dual chain operation is measured under the condition that both chains are output at same phase.



5.2.7 TEST RESULTS

RADIATED WORST-CASE DATA: BELOW 1GHz

EUT	ADSL Modem with Wireless Pre-N Router	MEASUREMENT DETAIL	
MODEL	F5D8630-4	FREQUENCY RANGE	Below 1000MHz
CHANNEL	Channel 11	DETECTOR FUNCTION	Quasi-Peak
MODULATION TYPE	BPSK	ENVIRONMENTAL CONDITIONS	23deg. C, 64%RH, 991hPa
TRANSFER RATE	36Mbps	INPUT POWER (SYSTEM)	120Vac, 60 Hz
TESTED BY	Brad Wu		

ANTENNA POLARITY & TEST DISTANCE: HORIZONTAL AT 3 M

No.	Freq. (MHz)	Emission Level (dBuV/m)	Limit (dBuV/m)	Margin (dB)	Antenna Height (m)	Table Angle (Degree)	Raw Value (dBuV)	Correction Factor (dB/m)
1	249.66	37.46 QP	46.00	-8.54	1.00 H	148	24.36	13.11
2	350.74	31.70 QP	46.00	-14.30	1.00 H	202	16.16	15.54
3	500.42	32.88 QP	46.00	-13.12	1.50 H	175	14.30	18.58
4	560.68	43.73 QP	46.00	-2.27	1.75 H	142	23.98	19.75
5	702.59	28.63 QP	46.00	-17.37	1.00 H	175	6.56	22.07
6	896.97	31.75 QP	46.00	-14.25	1.50 H	289	6.99	24.76

ANTENNA POLARITY & TEST DISTANCE: VERTICAL AT 3 M

No.	Freq. (MHz)	Emission Level (dBuV/m)	Limit (dBuV/m)	Margin (dB)	Antenna Height (m)	Table Angle (Degree)	Raw Value (dBuV)	Correction Factor (dB/m)
1	30.00	38.39 QP	40.00	-1.61	1.00 V	181	24.72	13.67
2	74.71	37.91 QP	40.00	-2.09	1.00 V	190	26.66	11.25
3	249.66	34.13 QP	46.00	-11.87	1.00 V	199	21.03	13.11
4	399.34	28.89 QP	46.00	-17.11	1.50 V	208	12.18	16.71
5	560.68	43.19 QP	46.00	-2.81	1.00 V	199	23.43	19.75
6	799.78	29.67 QP	46.00	-16.33	1.50 V	52	6.21	23.46

- REMARKS:**
1. Emission level (dBuV/m) = Raw Value (dBuV) + Correction Factor (dB/m).
 2. Correction Factor (dB/m) = Antenna Factor (dB/m) + Cable Factor (dB).
 3. The other emission levels were very low against the limit.
 4. Margin value = Emission level – Limit value.



802.11g OFDM MODULATION

EUT	ADSL Modem with Wireless Pre-N Router	MEASUREMENT DETAIL	
MODEL	F5D8630-4	FREQUENCY RANGE	1 ~ 25GHz
CHANNEL	Channel 1	DETECTOR FUNCTION	Peak (PK) Average (AV)
MODULATION TYPE	BPSK	ENVIRONMENTAL CONDITIONS	22deg. C, 67%RH, 991hPa
TRANSFER RATE	36Mbps	INPUT POWER (SYSTEM)	120Vac, 60 Hz
TESTED BY	Brad Wu		

ANTENNA POLARITY & TEST DISTANCE: HORIZONTAL AT 3 M

No.	Freq. (MHz)	Emission Level (dBuV/m)	Limit (dBuV/m)	Margin (dB)	Antenna Height (m)	Table Angle (Degree)	Raw Value (dBuV)	Correction Factor (dB/m)
1	1680.00	45.19 PK	74.00	-28.81	1.06 H	194	14.60	30.59
1	1680.00	39.57 AV	54.00	-14.43	1.06 H	194	8.98	30.59
2	2390.00	54.75 PK	74.00	-19.25	1.08 H	347	22.19	32.56
2	*2390.00	42.57 AV	54.00	-11.43	1.08 H	347	10.01	32.56
3	*2412.00	100.42 PK			1.08 H	347	67.81	32.61
3	2412.00	88.20 AV			1.08 H	347	55.59	32.61
4	4824.00	49.57 PK	74.00	-24.43	1.09 H	206	9.73	39.84
4	4824.00	37.46 AV	54.00	-16.54	1.09 H	206	-2.38	39.84

ANTENNA POLARITY & TEST DISTANCE: VERTICAL AT 3 M

No.	Freq. (MHz)	Emission Level (dBuV/m)	Limit (dBuV/m)	Margin (dB)	Antenna Height (m)	Table Angle (Degree)	Raw Value (dBuV)	Correction Factor (dB/m)
1	1680.00	46.23 PK	74.00	-27.77	1.00 V	116	15.64	30.59
1	1680.00	40.69 AV	54.00	-13.31	1.00 V	116	10.10	30.59
2	2390.00	65.51 PK	74.00	-8.49	1.13 V	3	32.95	32.56
2	2390.00	52.29 AV	54.00	-1.71	1.13 V	3	19.73	32.56
3	*2412.00	107.43 PK			1.37 V	358	74.82	32.61
3	*2412.00	96.31 AV			1.37 V	358	63.70	32.61
4	4824.00	50.51 PK	74.00	-23.49	1.02 V	213	10.67	39.84
4	4824.00	38.47 AV	54.00	-15.53	1.02 V	213	-1.37	39.84

- REMARKS:**
1. Emission level (dBuV/m) = Raw Value (dBuV) + Correction Factor (dB/m).
 2. Correction Factor (dB/m) = Antenna Factor (dB/m) + Cable Factor (dB).
 3. The other emission levels were very low against the limit.
 4. Margin value = Emission level – Limit value.
 5. “ * “: Fundamental frequency.



EUT	ADSL Modem with Wireless Pre-N Router	MEASUREMENT DETAIL	
MODEL	F5D8630-4	FREQUENCY RANGE	1 ~ 25GHz
CHANNEL	Channel 6	DETECTOR FUNCTION	Peak (PK) Average (AV)
MODULATION TYPE	BPSK	ENVIRONMENTAL CONDITIONS	22deg. C, 67%RH, 991hPa
TRANSFER RATE	36Mbps	INPUT POWER (SYSTEM)	120Vac, 60 Hz
TESTED BY	Brad Wu		

ANTENNA POLARITY & TEST DISTANCE: HORIZONTAL AT 3 M

No.	Freq. (MHz)	Emission Level (dBuV/m)	Limit (dBuV/m)	Margin (dB)	Antenna Height (m)	Table Angle (Degree)	Raw Value (dBuV)	Correction Factor (dB/m)
1	1740.00	49.73 PK	74.00	-24.27	1.01 H	195	18.95	30.78
1	1740.00	47.26 AV	54.00	-6.74	1.01 H	195	16.48	30.78
2	*2437.00	103.42 PK			1.12 H	356	70.75	32.67
2	*2437.00	91.28 AV			1.12 H	356	58.61	32.67
3	4874.00	49.56 PK	74.00	-24.44	1.09 H	224	9.51	40.05
3	4874.00	37.58 AV	54.00	-16.42	1.09 H	224	-2.47	40.05

ANTENNA POLARITY & TEST DISTANCE: VERTICAL AT 3 M

No.	Freq. (MHz)	Emission Level (dBuV/m)	Limit (dBuV/m)	Margin (dB)	Antenna Height (m)	Table Angle (Degree)	Raw Value (dBuV)	Correction Factor (dB/m)
1	1740.00	51.03 PK	74.00	-22.97	1.03 V	28	20.25	30.78
1	1740.00	48.56 AV	54.00	-5.44	1.03 V	28	17.78	30.78
2	*2437.00	110.46 PK			1.11 V	11	77.79	32.67
2	*2437.00	98.34 AV			1.11 V	11	65.67	32.67
3	4874.00	51.24 PK	74.00	-22.76	1.06 V	259	11.19	40.05
3	4874.00	39.28 AV	54.00	-14.72	1.06 V	259	-0.77	40.05

- REMARKS:**
1. Emission level (dBuV/m) = Raw Value (dBuV) + Correction Factor (dB/m).
 2. Correction Factor (dB/m) = Antenna Factor (dB/m) + Cable Factor (dB).
 3. The other emission levels were very low against the limit.
 4. Margin value = Emission level – Limit value.
 5. “ * “: Fundamental frequency.



EUT	ADSL Modem with Wireless Pre-N Router	MEASUREMENT DETAIL	
MODEL	F5D8630-4	FREQUENCY RANGE	1 ~ 25GHz
CHANNEL	Channel 11	DETECTOR FUNCTION	Peak (PK) Average (AV)
MODULATION TYPE	BPSK	ENVIRONMENTAL CONDITIONS	22deg. C, 67%RH, 991hPa
TRANSFER RATE	36Mbps	INPUT POWER (SYSTEM)	120Vac, 60 Hz
TESTED BY	Brad Wu		

ANTENNA POLARITY & TEST DISTANCE: HORIZONTAL AT 3 M								
No.	Freq. (MHz)	Emission Level (dBuV/m)	Limit (dBuV/m)	Margin (dB)	Antenna Height (m)	Table Angle (Degree)	Raw Value (dBuV)	Correction Factor (dB/m)
1	1760.00	50.06 PK	74.00	-23.94	1.07 H	203	19.23	30.83
1	1760.00	47.53 AV	54.00	-6.47	1.07 H	203	16.70	30.83
2	*2462.00	104.51 PK			1.10 H	351	71.78	32.73
2	*2462.00	92.33 AV			1.10 H	351	59.59	32.73
3	2483.50	57.32 PK	74.00	-16.68	1.10 H	351	24.53	32.79
3	2483.50	45.15 AV	54.00	-8.85	1.10 H	351	12.36	32.79
4	4924.00	50.47 PK	74.00	-23.53	1.11 H	213	10.20	40.27
4	4924.00	38.41 AV	54.00	-15.59	1.11 H	213	-1.86	40.27

ANTENNA POLARITY & TEST DISTANCE: VERTICAL AT 3 M								
No.	Freq. (MHz)	Emission Level (dBuV/m)	Limit (dBuV/m)	Margin (dB)	Antenna Height (m)	Table Angle (Degree)	Raw Value (dBuV)	Correction Factor (dB/m)
1	1760.00	52.14 PK	74.00	-21.86	1.00 V	24	21.31	30.83
1	1760.00	49.70 AV	54.00	-4.30	1.00 V	24	18.87	30.83
2	*2462.00	111.97 PK			1.11 V	6	79.23	32.73
2	*2462.00	99.36 AV			1.11 V	6	66.63	32.73
3	2483.50	65.07 PK	74.00	-8.93	1.12 V	17	32.28	32.79
3	2483.50	52.42 AV	54.00	-1.58	1.12 V	17	19.63	32.79
4	4924.00	51.62 PK	74.00	-22.38	1.07 V	249	11.35	40.27
4	4924.00	39.58 AV	54.00	-14.42	1.07 V	249	-0.69	40.27

- REMARKS:**
1. Emission level (dBuV/m) = Raw Value (dBuV) + Correction Factor (dB/m).
 2. Correction Factor (dB/m) = Antenna Factor (dB/m) + Cable Factor (dB).
 3. The other emission levels were very low against the limit.
 4. Margin value = Emission level – Limit value.
 5. “ * “: Fundamental frequency.



5.3 6dB BANDWIDTH MEASUREMENT

5.3.1 LIMITS OF 6dB BANDWIDTH MEASUREMENT

The minimum of 6dB Bandwidth Measurement is 0.5 MHz.

5.3.2 TEST INSTRUMENTS

DESCRIPTION & MANUFACTURER	MODEL NO.	SERIAL NO.	CALIBRATED UNTIL
SPECTRUM ANALYZER	FSEK30	100049	Aug. 14, 2006

NOTE: The calibration interval of the above test instruments is 12 months and the calibrations are traceable to NML/ROC and NIST/USA.

5.3.3 TEST PROCEDURE

The transmitter output was connected to the spectrum analyzer through an attenuator. The bandwidth of the fundamental frequency was measured by spectrum analyzer with 100 kHz RBW and 100kHz VBW. The 6dB bandwidth is defined as the total spectrum the power of which is higher than peak power minus 6dB.

5.3.4 DEVIATION FROM TEST STANDARD

No deviation

5.3.5 TEST SETUP

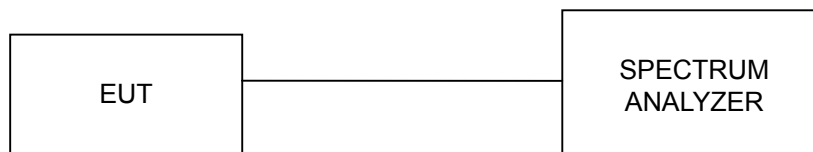

For the actual test configuration, please refer to the related Item – Photographs of the Test Configuration.

5.3.6 EUT OPERATING CONDITIONS

The software provided by client to enable the EUT under transmission condition continuously at lowest, middle and highest channel frequencies individually.



5. 3.7 TEST RESULTS

802.11g OFDM MODULATION

EUT	ADSL Modem with Wireless Pre-N Router	MODEL	F5D8630-4
MODULATION TYPE	BPSK	TRANSFER RATE	36Mbps
INPUT POWER (SYSTEM)	120Vac, 60 Hz	ENVIRONMENTAL CONDITIONS	23deg. C, 64%RH, 991hPa
TESTED BY	Brad Wu		

CHANNEL	CHANNEL FREQUENCY (MHz)	6dB BANDWIDTH (MHz)		MINIMUM LIMIT (MHz)	PASS/FAIL
		CHAIN 0	CHAIN 1		
1	2412	15.68	15.68	0.5	PASS
6	2437	16.00	15.76	0.5	PASS
11	2462	16.24	16.16	0.5	PASS



FOR CHAIN 0:
CH1

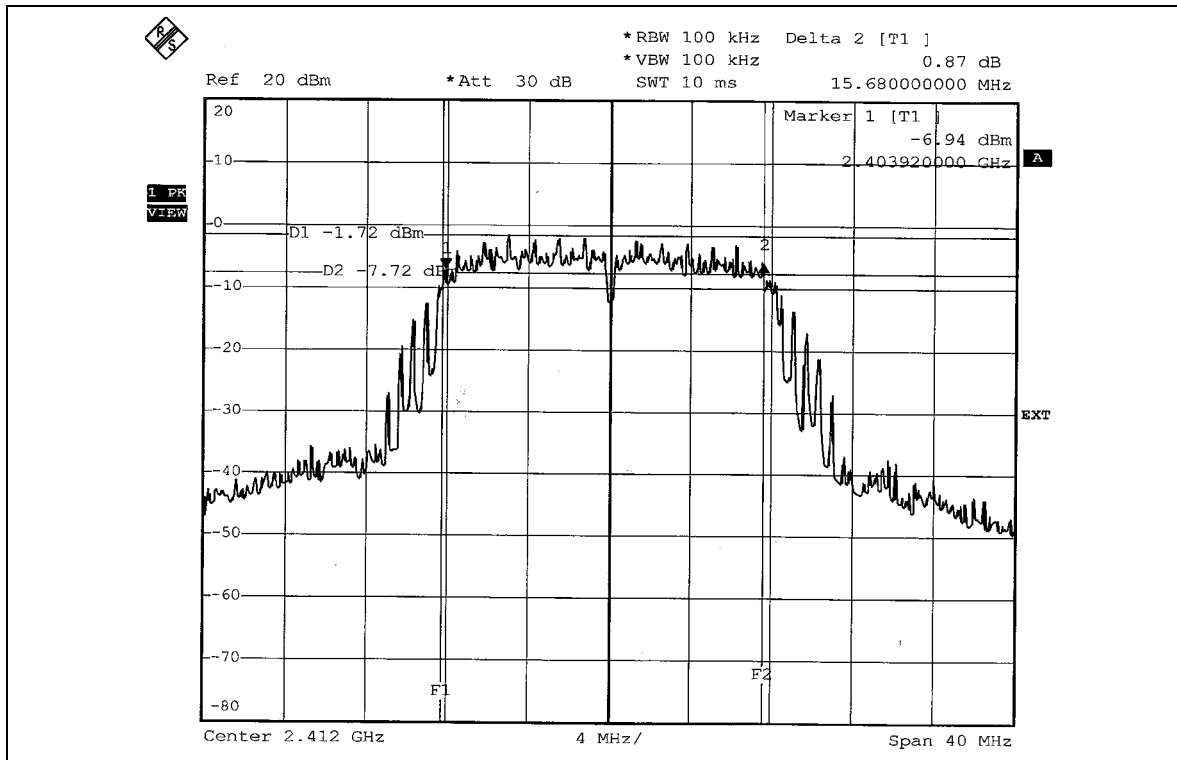

CH6

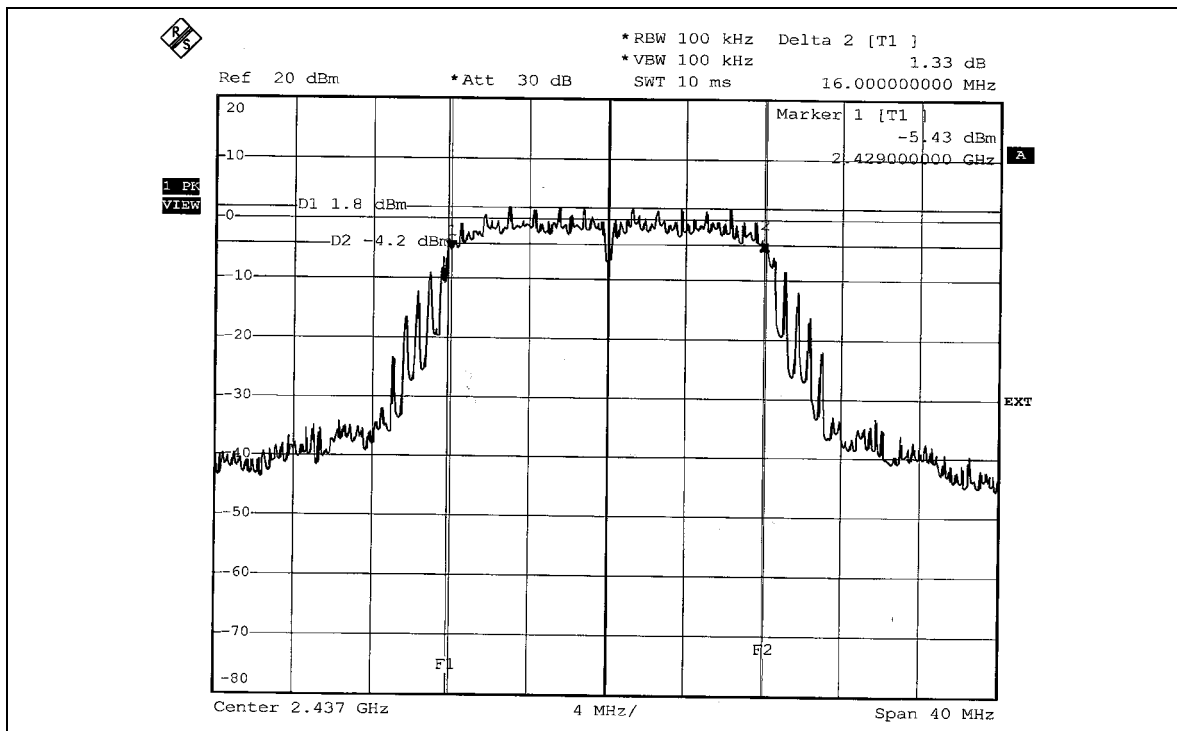



CH11

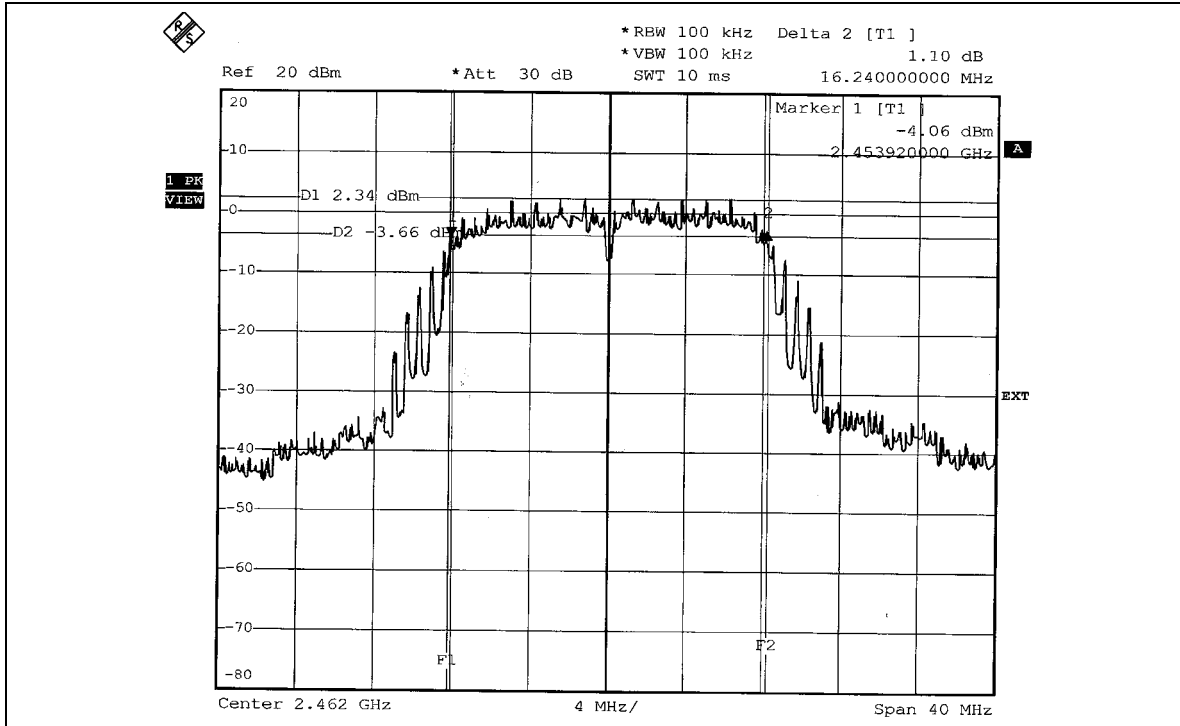

FOR CHAIN 1:

CH1

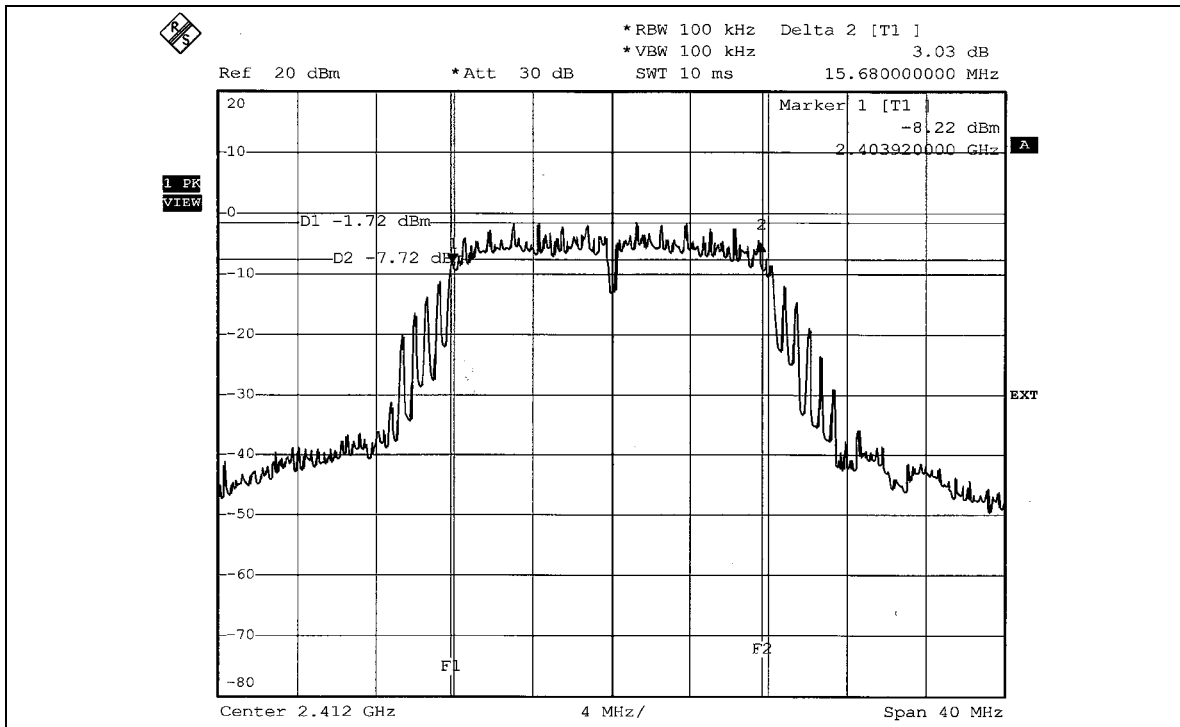



CH6

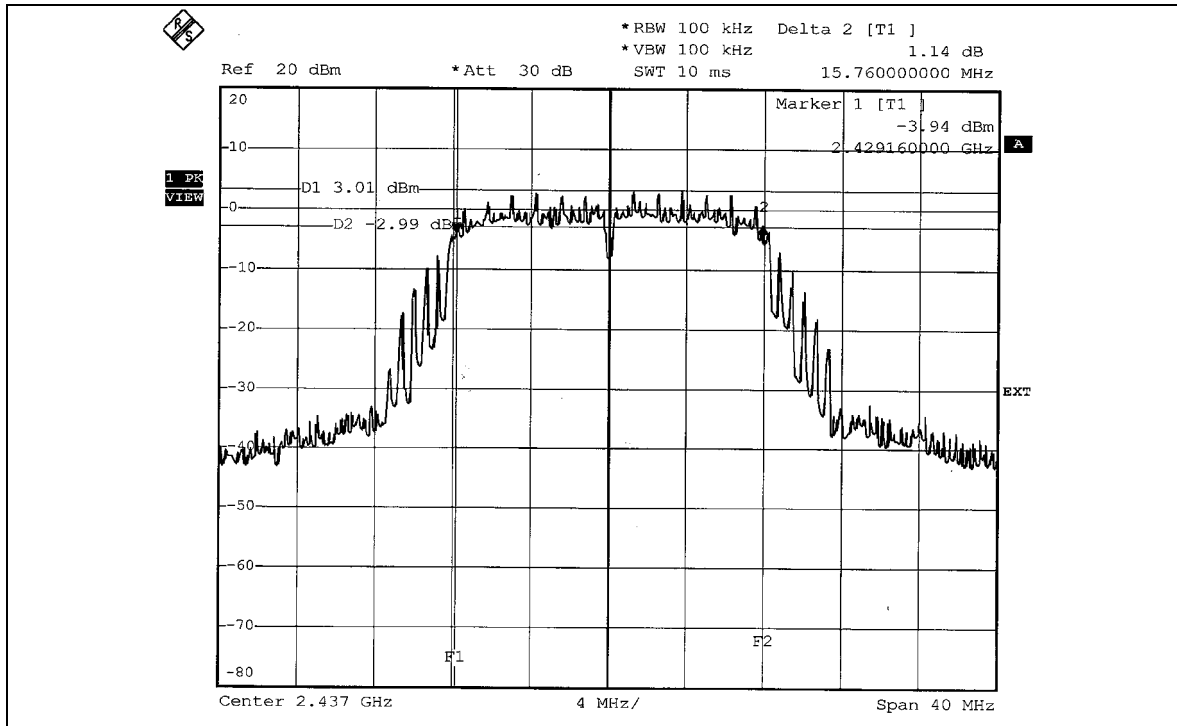

CH11

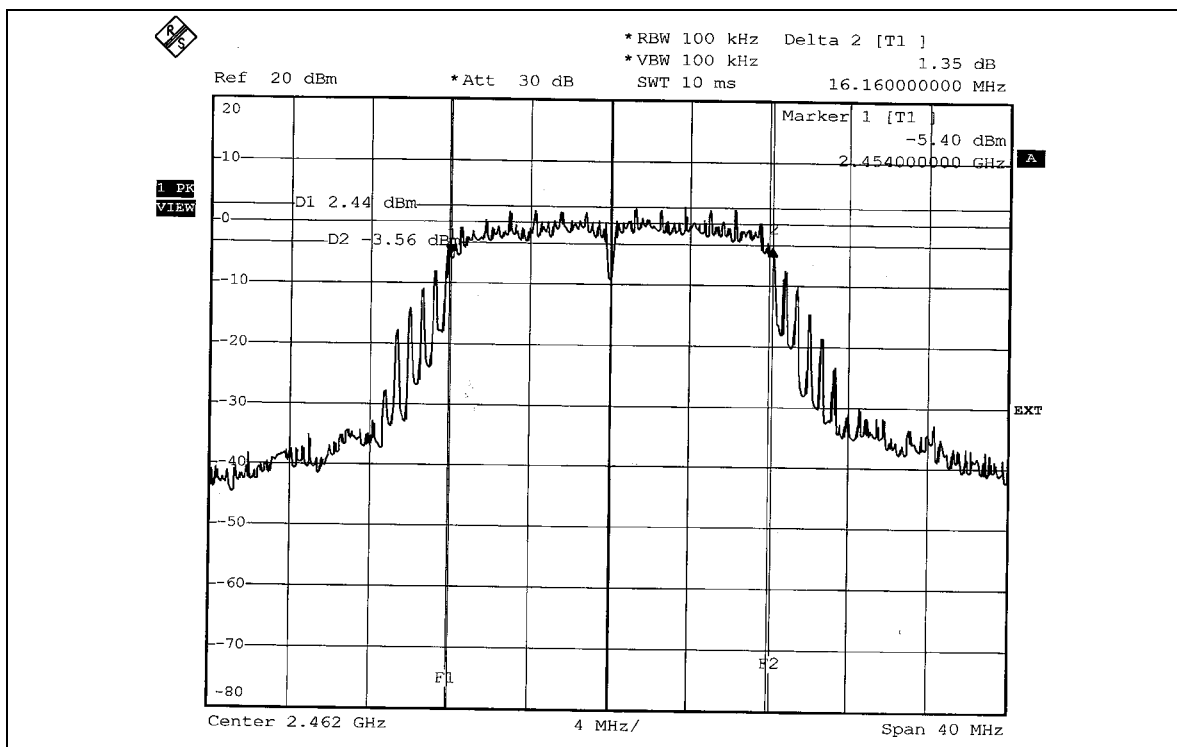



5.4 MAXIMUM PEAK OUTPUT POWER

5.4.1 LIMITS OF MAXIMUM PEAK OUTPUT POWER MEASUREMENT

The Maximum Peak Output Power Measurement is 30dBm.

5.4.2 TEST INSTRUMENTS

DESCRIPTION & MANUFACTURER	MODEL NO.	SERIAL NO.	CALIBRATED UNTIL
R&S SPECTRUM ANALYZER	FSEK30	100049	Aug. 14, 2006
AGILENT SIGNAL GENERATOR	E8257C	MY43320668	Dec. 06, 2005
DIGITAL RT OSCILLOSCOPE	TDS1012	C037299	Dec. 07, 2005
NARDA DETECTOR	4503A	FSCM99899	NA

NOTE: The calibration interval of the above test instruments is 12 months and the calibrations are traceable to NML/ROC and NIST/USA.



5.4.3 TEST PROCEDURES

1. A detector was used on the output port of the EUT. An oscilloscope was used to peak the response of the detector.
2. Replaced the EUT by the signal generator. The center frequency of the S.G was adjusted to the center frequency of the measured channel.
3. Adjusted the power to have the same peak reading on oscilloscope. Record the power level.

5.4.4 DEVIATION FROM TEST STANDARD

No deviation

5.4.5 TEST SETUP



5.4.6 EUT OPERATING CONDITIONS

Same as Item 5.3.6



5.4.7 TEST RESULTS

802.11g OFDM MODULATION

EUT	ADSL Modem with Wireless Pre-N Router	MODEL	F5D8630-4
MODULATION TYPE	BPSK	TRANSFER RATE	36Mbps
INPUT POWER (SYSTEM)	120Vac, 60 Hz	ENVIRONMENTAL CONDITIONS	23deg. C, 64%RH, 991hPa
TESTED BY	Brad Wu		

CHANNEL	CHANNEL FREQUENCY (MHz)	PEAK POWER OUTPUT (mW)		PEAK POWER OUTPUT (dBm)		TOTAL PEAK POWER (mW)	TOTAL PEAK POWER (dBm)	PEAK POWER LIMIT (dBm)	PASS/FAIL
		CHAIN 0	CHAIN 1	CHAIN 0	CHAIN 1				
1	2412	22.387	21.777	13.50	13.38	44.164	16.45	30	PASS
6	2437	32.063	31.261	15.06	14.95	63.324	18.02	30	PASS
11	2462	31.769	31.477	15.02	14.98	63.246	18.01	30	PASS



5.5 POWER SPECTRAL DENSITY MEASUREMENT

5.5.1 LIMITS OF POWER SPECTRAL DENSITY MEASUREMENT

The Maximum of Power Spectral Density Measurement is 8dBm.

5.5.2 TEST INSTRUMENTS

DESCRIPTION & MANUFACTURER	MODEL NO.	SERIAL NO.	CALIBRATED UNTIL
SPECTRUM ANALYZER	FSEK30	100049	Aug. 14, 2006

NOTE: The calibration interval of the above test instruments is 12 months and the calibrations are traceable to NML/ROC and NIST/USA.

5.5.3 TEST PROCEDURE

The transmitter output was connected to the spectrum analyzer through an attenuator, the bandwidth of the fundamental frequency was measured with the spectrum analyzer using 3kHz RBW and 30kHz VBW, set sweep time=span/3kHz. The power spectral density was measured and recorded.

The sweep time is allowed to be longer than span/3kHz for a full response of the mixer in the spectrum analyzer.

5.5.4 DEVIATION FROM TEST STANDARD

No deviation

5.5.5 TEST SETUP



5.5.6 EUT OPERATING CONDITIONS

Same as 4.3.6



5.5.7 TEST RESULTS

802.11g OFDM MODULATION

EUT	ADSL Modem with Wireless Pre-N Router	MODEL	F5D8630-4
MODULATION TYPE	BPSK	TRANSFER RATE	36Mbps
INPUT POWER (SYSTEM)	120Vac, 60 Hz	ENVIRONMENTAL CONDITIONS	23deg. C, 64%RH, 991hPa
TESTED BY	Brad Wu		

CHANNEL	CHANNEL FREQUENCY (MHz)	RF POWER LEVEL IN 3 kHz BW (dBm)		MAXIMUM LIMIT (dBm)	PASS/FAIL
		CHAIN 0	CHAIN 1		
1	2412	-15.78	-16.06	8	PASS
6	2437	-13.96	-14.13	8	PASS
11	2462	-13.53	-13.75	8	PASS



FOR CHAIN 0:
CH1

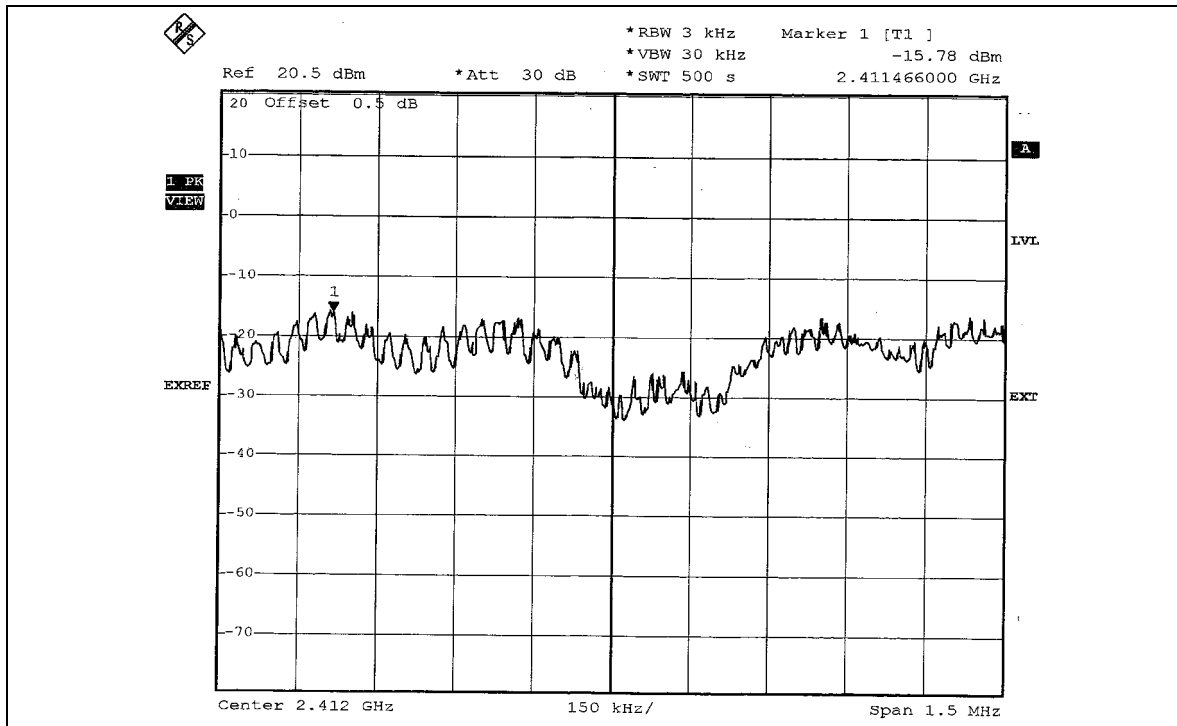

CH6

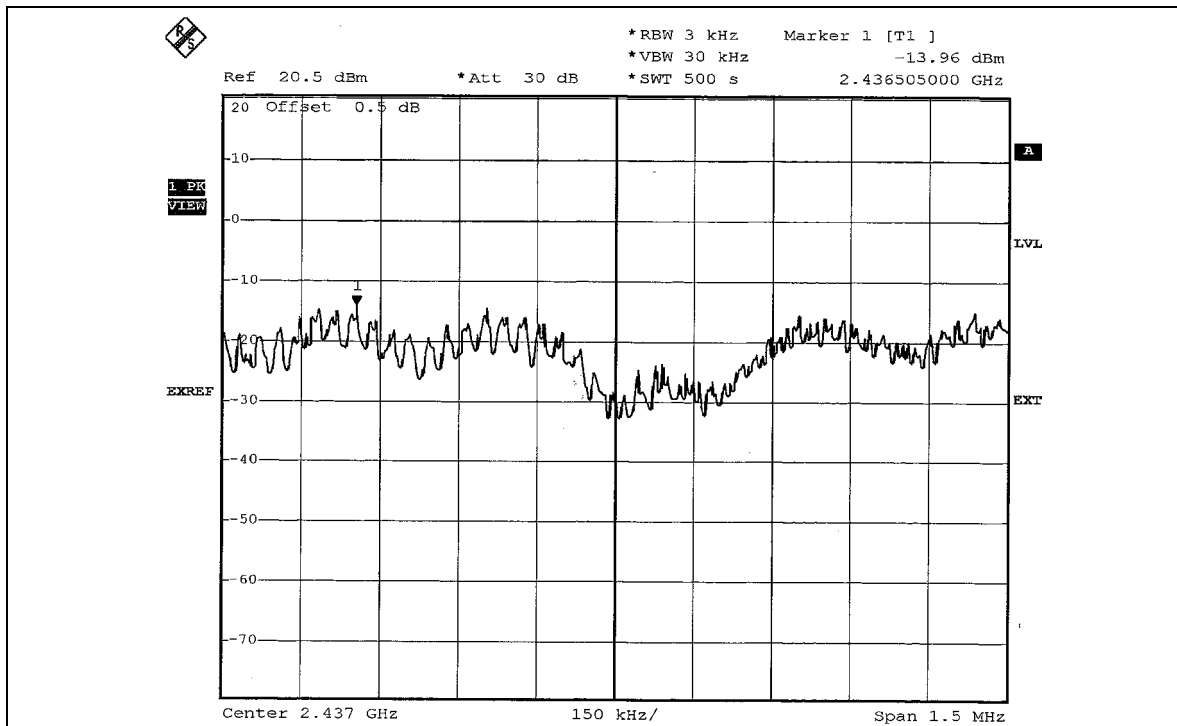



CH11

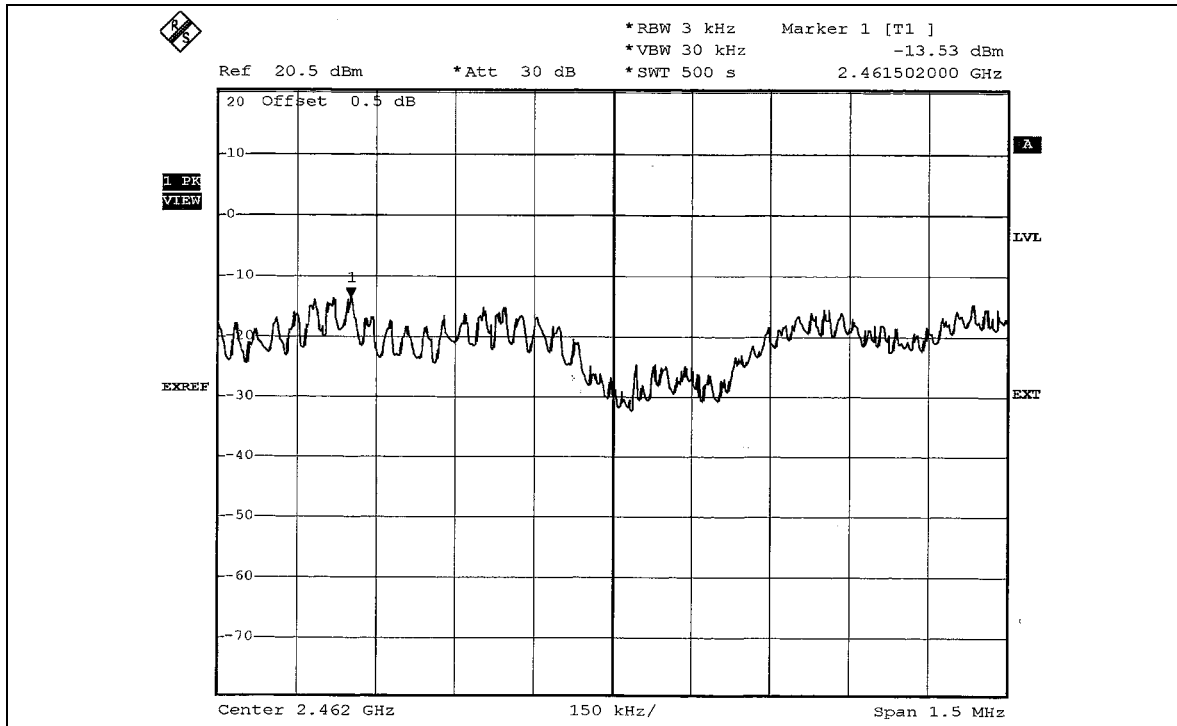

FOR CHAIN 1:

CH1

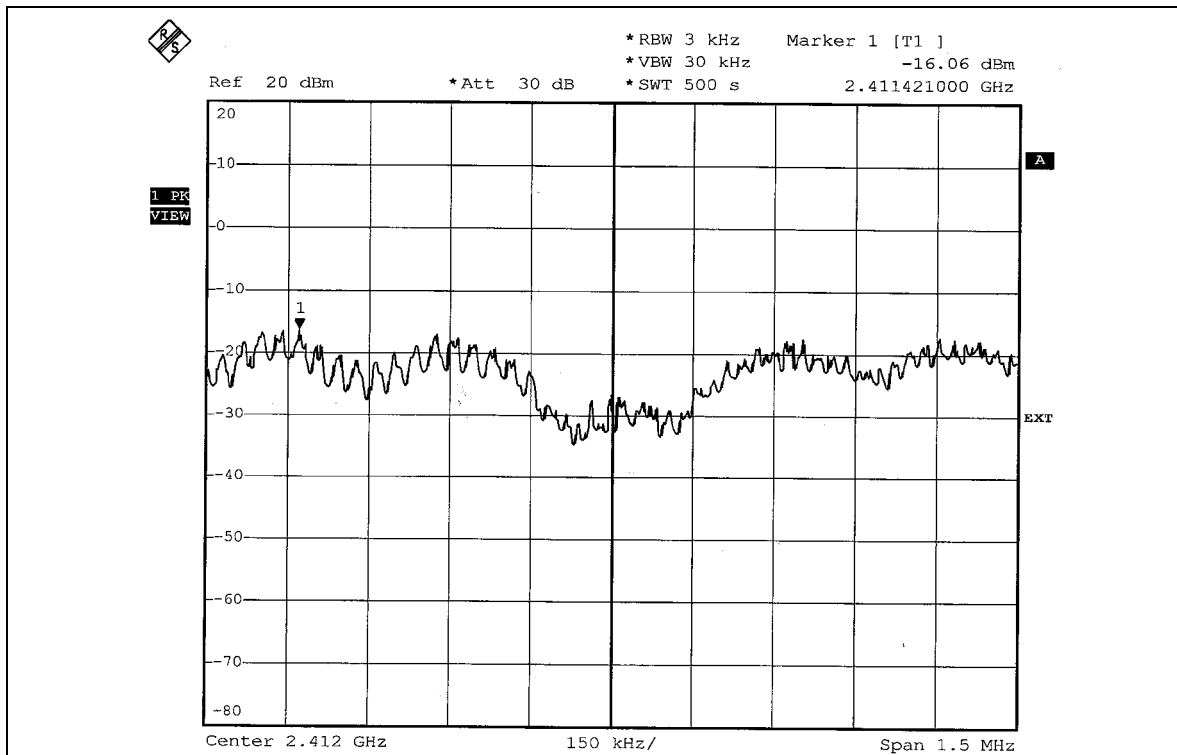



CH6

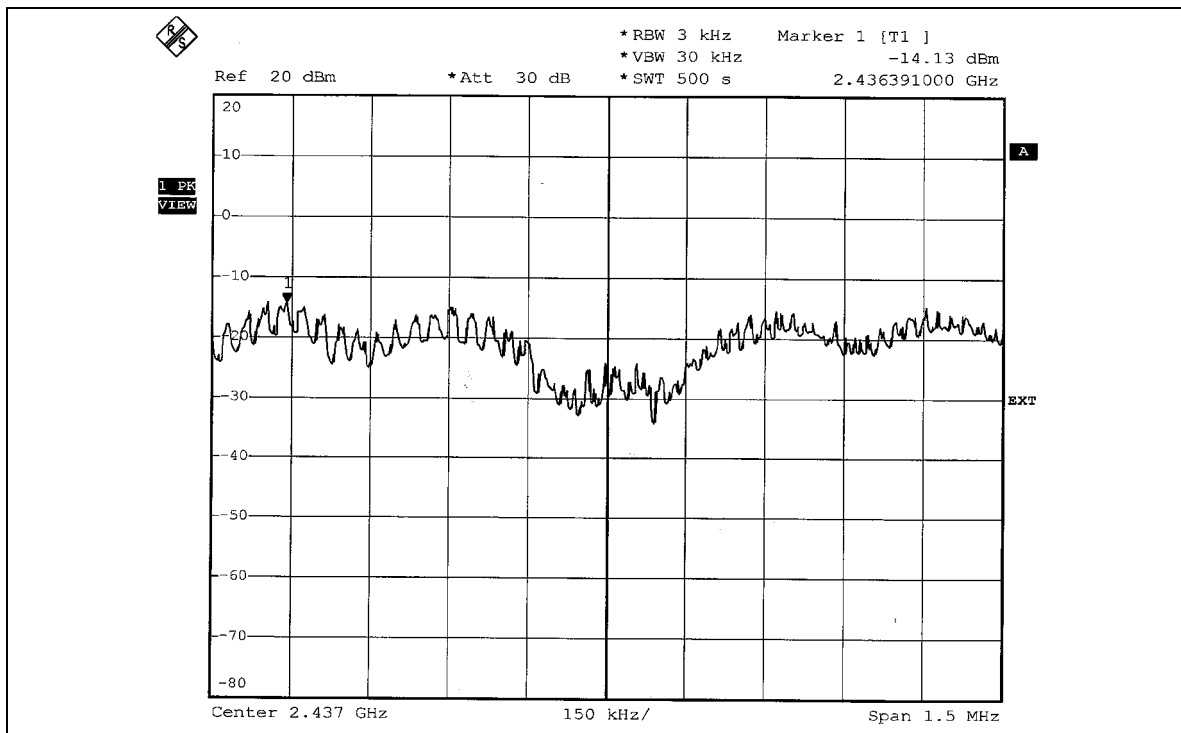

CH11

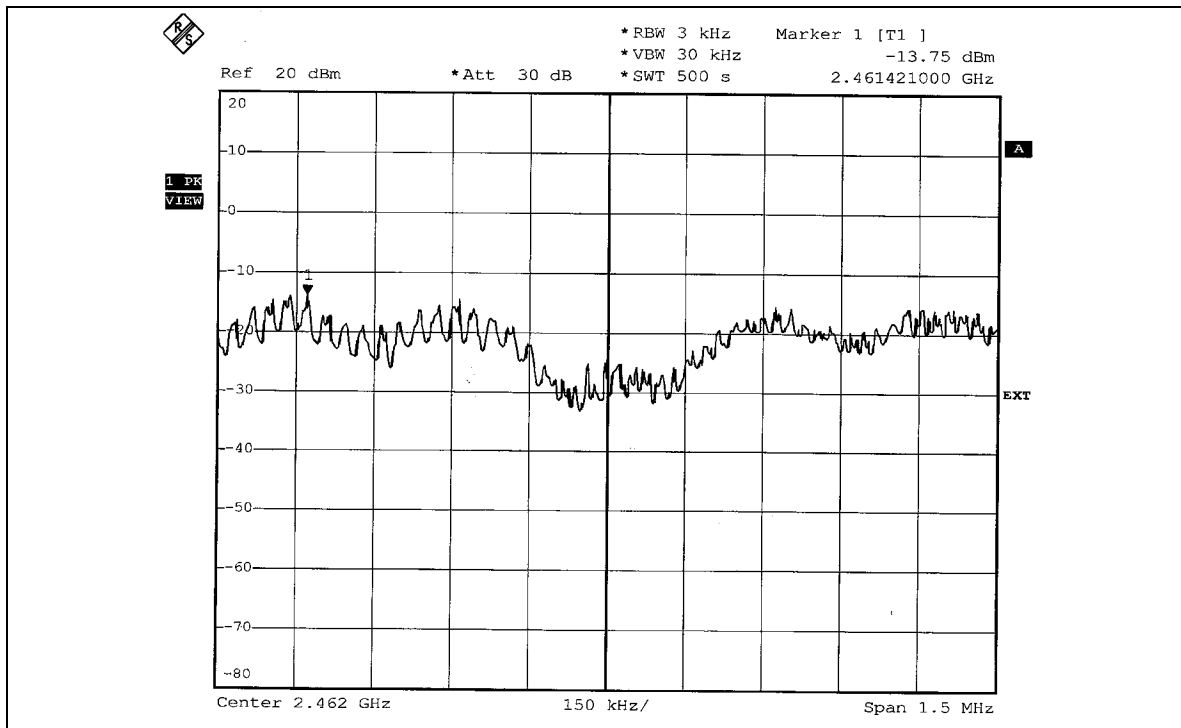



5.6 BAND EDGES MEASUREMENT

5.6.1 LIMITS OF BAND EDGES MEASUREMENT

Below -20dB of the highest emission level of operating band (in 100kHz Resolution Bandwidth).

5.6.2 TEST INSTRUMENTS

DESCRIPTION & MANUFACTURER	MODEL NO.	SERIAL NO.	CALIBRATED UNTIL
SPECTRUM ANALYZER	FSEK30	100049	Aug. 14, 2006

NOTE: The calibration interval of the above test instruments is 12 months and the calibrations are traceable to NML/ROC and NIST/USA.



5.6.3 TEST PROCEDURE

- a. The EUT was placed on the top of a rotating table 0.8 meters above the ground at a 3 meter semi-anechoic chamber. The table was rotated 360 degrees to determine the position of the highest radiation.
- b. The EUT was set 3 meters away from the interference-receiving antenna, which was mounted on the top of a variable-height antenna tower.
- c. The antenna is a broadband antenna, and its height is varied from one meter to four meters above the ground to determine the maximum value of the field strength. Both horizontal and vertical polarizations of the antenna are set to make the measurement.
- d. For each suspected emission, the EUT was arranged to its worst case and then the antenna was tuned to heights from 1 meter to 4 meters and the rotatable table was turned from 0 degrees to 360 degrees to find the maximum reading.
- e. Set both RBW and VBW of spectrum analyzer to 100kHz with suitable frequency span including 100MHz bandwidth from band edge. The band edges was measured and recorded.

The spectrum plots (Peak RBW = VBW = 100kHz; Average RBW = 1MHz, VBW = 1kHz)

NOTE: The resolution bandwidth of test receiver/spectrum analyzer is 1 MHz and the video bandwidth is 1kHz for Average detection (AV) at frequency above 1GHz.

5.6.4 DEVIATION FROM TEST STANDARD

No deviation

5.6.5 EUT OPERATING CONDITION

Same as Item 4.3.6



5.6.6 TEST RESULTS

The spectrum plots are attached on the following 18 images. D1 line indicates the highest level, and D2 line indicates the 20dB offset below D1. It shows compliance with the requirement in part 15.247(d).

802.11g OFDM MODULATION

NOTE 1: The band edge emission plot on page 97 shows 48.71dBc between carrier maximum power and local maximum emission in restrict band (2.3871GHz). The emission of carrier strength list in the test result of channel 1 at the item 5.2.7 is 107.43dBuV/m (Peak), so the maximum field strength in restrict band is $107.43 - 48.71 = 58.72$ dBuV/m, which is under 74dBuV/m limit.

The band edge emission plot on page 97 shows 47.48dBc between carrier maximum power and local maximum emission in restrict band (2.3900GHz). The emission of carrier strength list in the test result of channel 1 at the item 5.2.7 is 96.31dBuV/m (Average), so the maximum field strength in restrict band is $96.31 - 47.48 = 48.83$ dBuV/m, which is under 54dBuV/m limit.

NOTE 2: The band edge emission plot on page 98 shows 51.98dBc between carrier maximum power and local maximum emission in restrict band (2.5000GHz). The emission of carrier strength list in the test result of channel 11 at the item 5.2.7 is 111.97dBuV/m (Peak), so the maximum field strength in restrict band is $111.97 - 51.98 = 59.99$ dBuV/m, which is under 74dBuV/m limit.

The band edge emission plot on page 99 shows 49.90dBc between carrier maximum power and local maximum emission in restrict band (2.5000GHz). The emission of carrier strength list in the test result of channel 11 at the item 5.2.7 is 99.36dBuV/m (Average), so the maximum field strength in restrict band is $99.36 - 49.90 = 49.46$ dBuV/m, which is under 54dBuV/m limit.

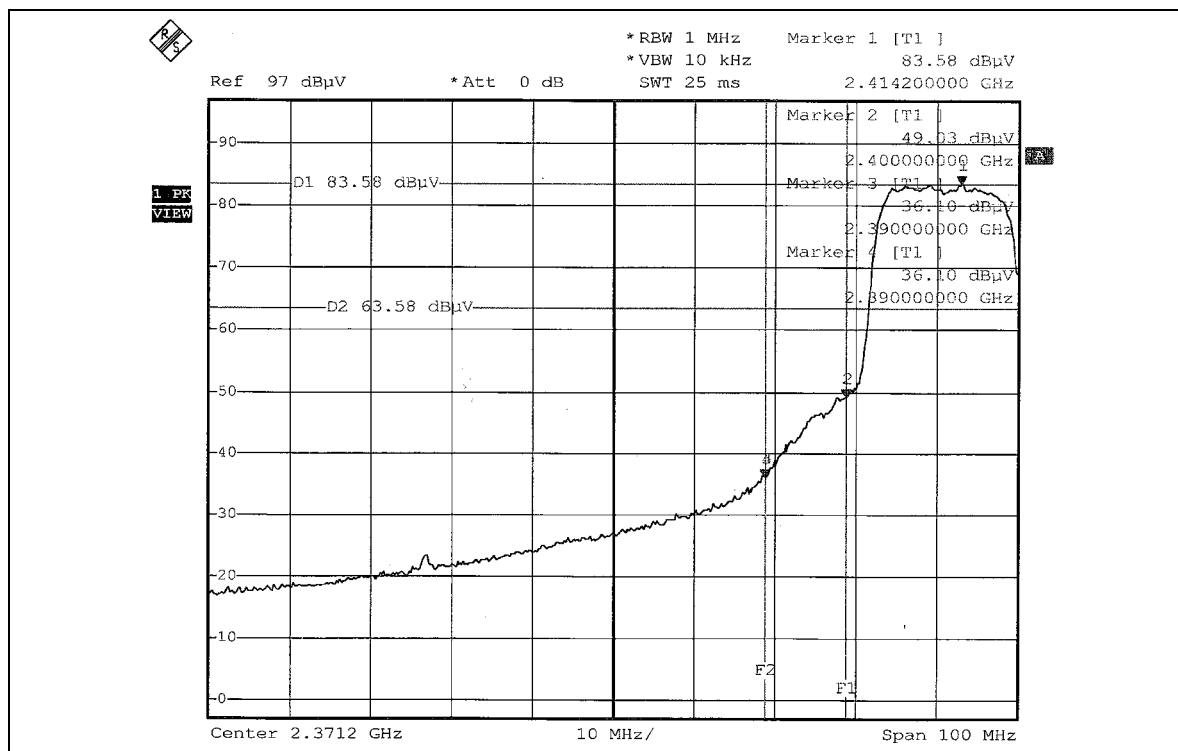
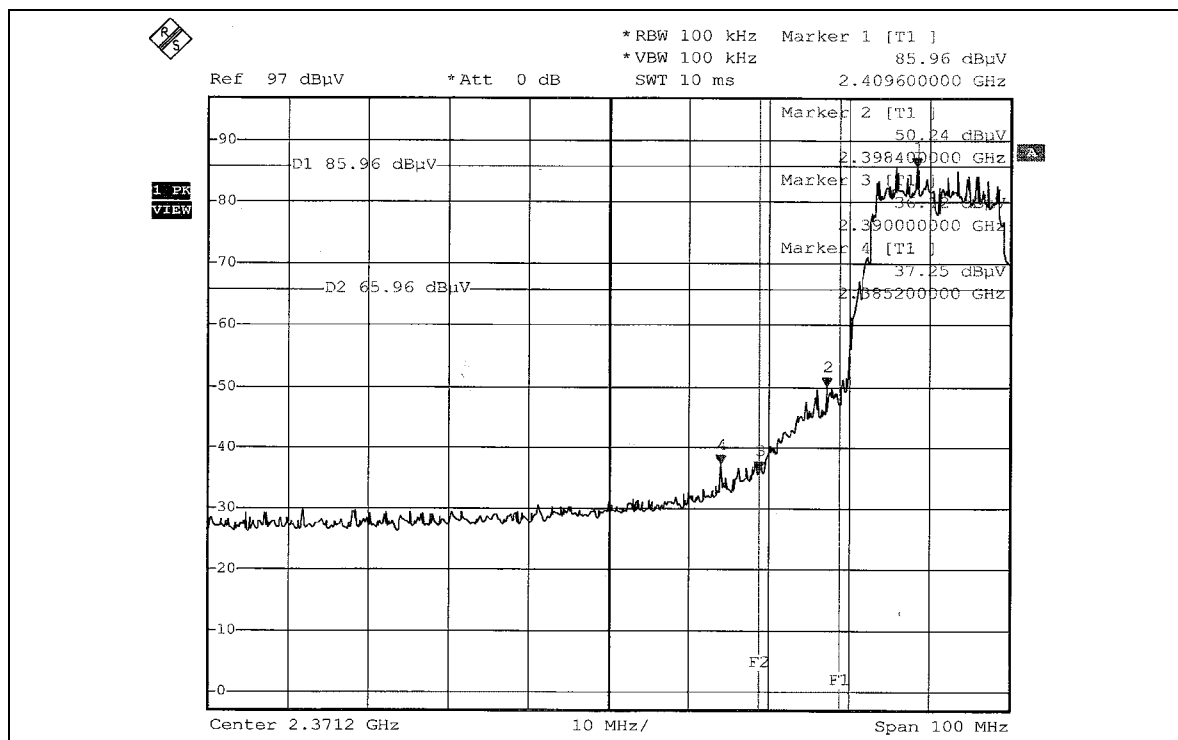

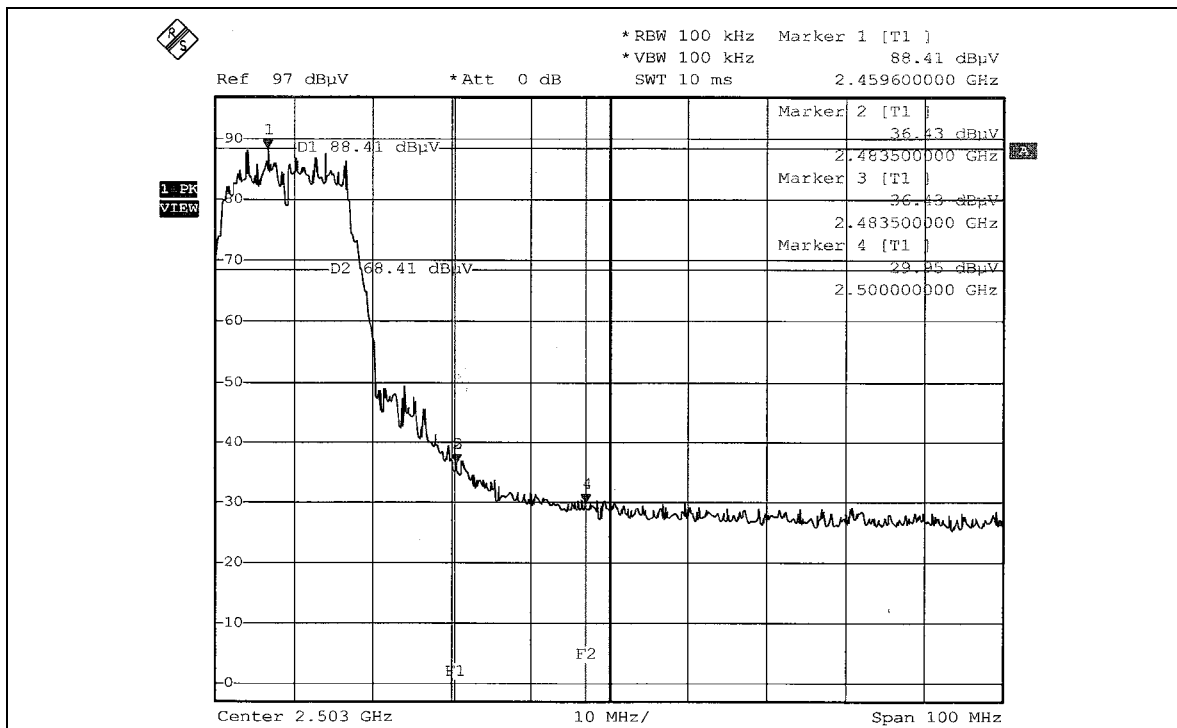
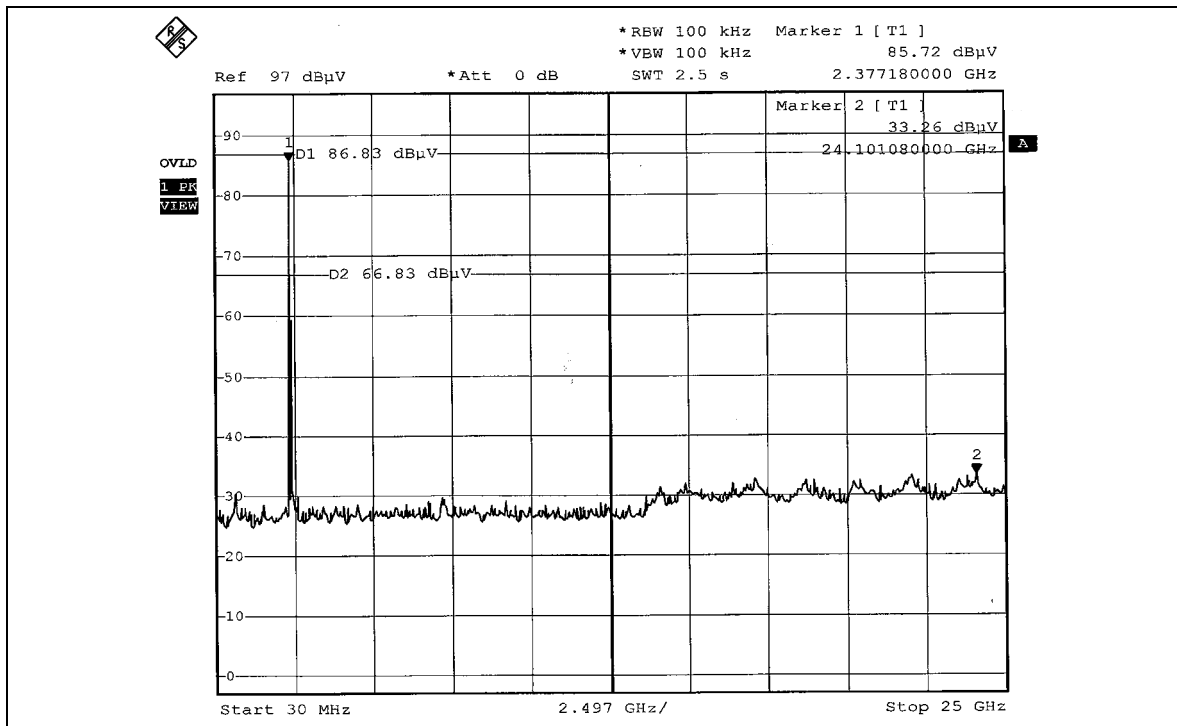

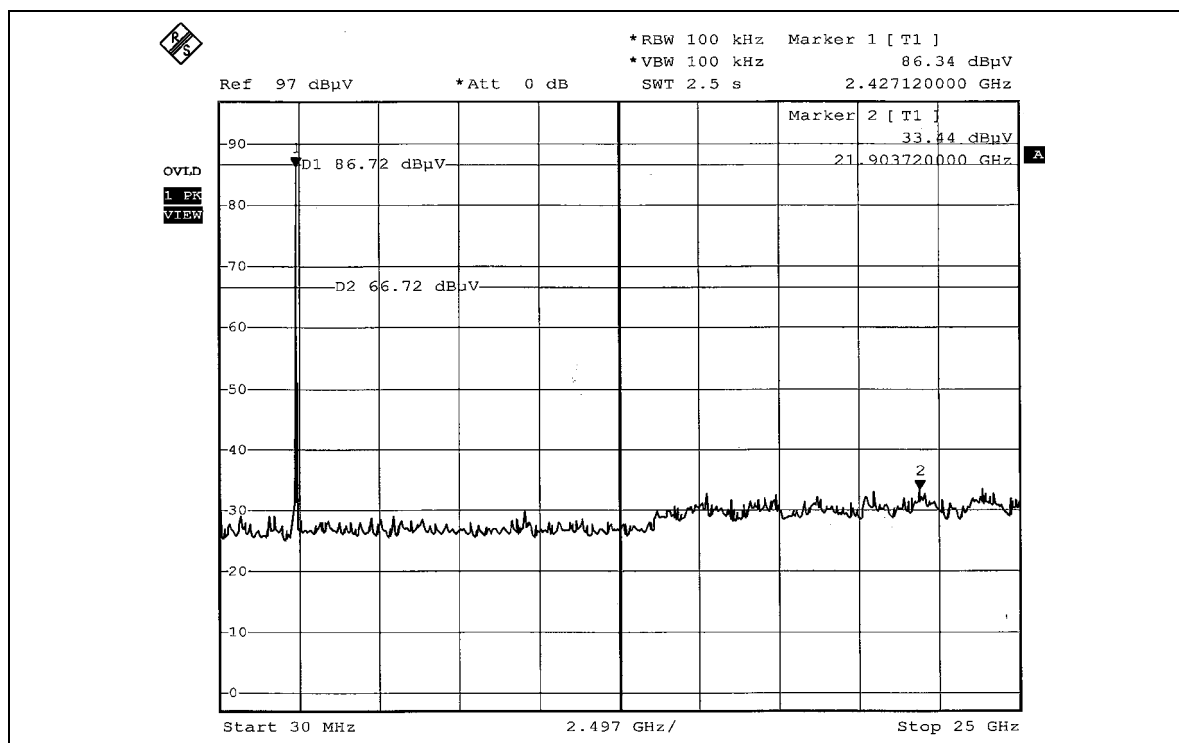
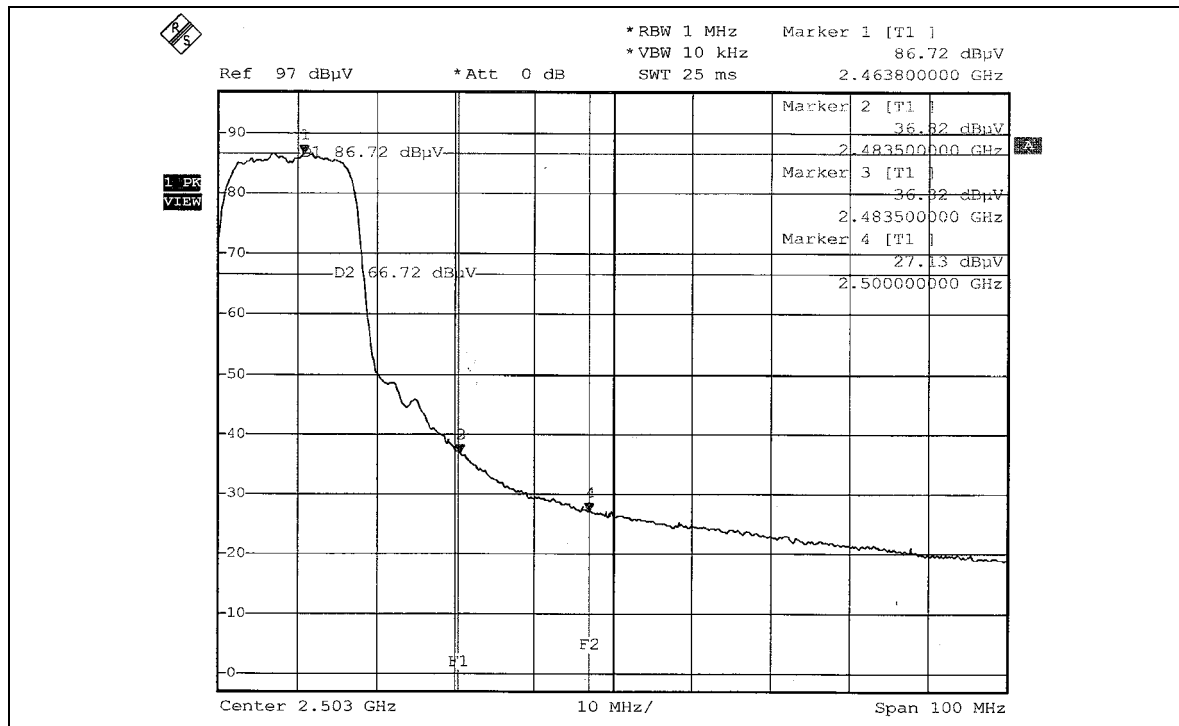



5.7 ANTENNA REQUIREMENT

5.7.1 STANDARD APPLICABLE

For intentional device, according to FCC 47 CFR Section 15.203, an intentional radiator shall be designed to ensure that no antenna other than that furnished by the responsible party shall be used with the device.

And according to FCC 47 CFR Section 15.247 (b), if transmitting antennas of directional gain greater than 6dBi are used, the power shall be reduced by the amount in dB that the directional gain of the antenna exceeds 6dBi.

5.7.2 ANTENNA CONNECTED CONSTRUCTION

The antenna type used in this product is Dipole antenna with UFL connector. The maximum Gain of this antenna is only 2dBi.

6. PHOTOGRAPHS OF THE TEST CONFIGURATION

CONDUCTED EMISSION TEST



RADIATED EMISSION TEST

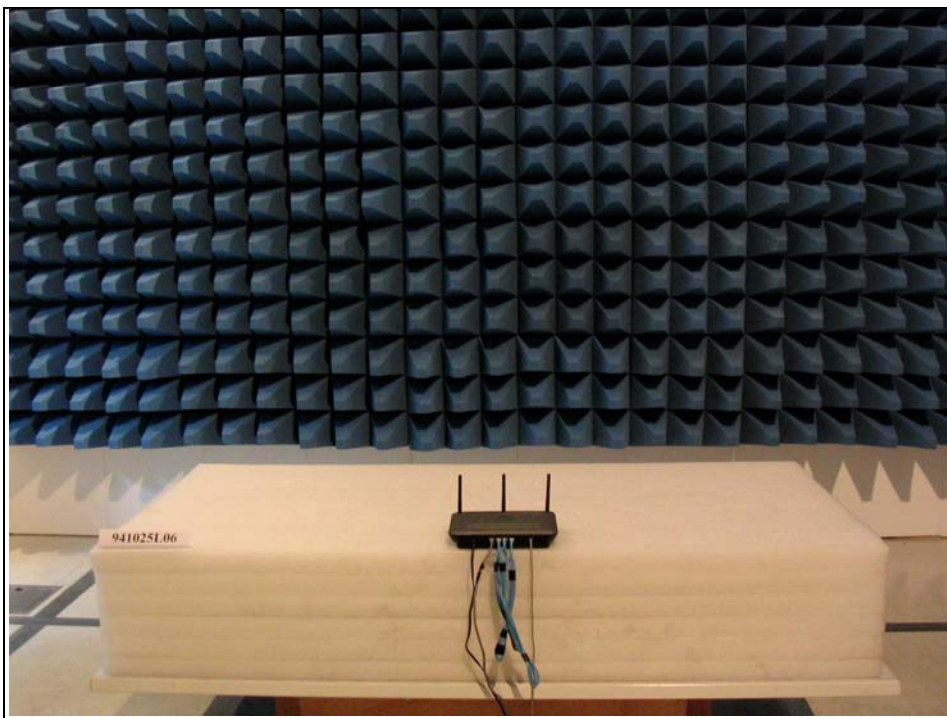



7. INFORMATION ON THE TESTING LABORATORIES

We, ADT Corp., were founded in 1988 to provide our best service in EMC, Radio, Telecom and Safety consultation. Our laboratories are accredited and approved by the following approval agencies according to ISO/IEC 17025.

USA	FCC, NVLAP, UL, A2LA
Germany	TUV Rheinland
Japan	VCCI
Norway	NEMKO
Canada	INDUSTRY CANADA , CSA
R.O.C.	CNLA, BSMI, DGT
Netherlands	Telefication
Singapore	PSB , GOST-ASIA(MOU)
Russia	CERTIS(MOU)

Copies of accreditation certificates of our laboratories obtained from approval agencies can be downloaded from our web site:

www.adt.com.tw/index.5/phtml. If you have any comments, please feel free to contact us at the following:

Linko EMC/RF Lab:

Tel: 886-2-26052180

Fax: 886-2-26052943

Hsin Chu EMC/RF Lab:

Tel: 886-3-5935343

Fax: 886-3-5935342

Hwa Ya EMC/RF/Safety/Telecom Lab: Linko RF Lab.

Tel: 886-3-3183232

Fax: 886-3-3185050

Tel: 886-3-3270910

Fax: 886-3-3270892

Web Site: www.adt.com.tw

The address and road map of all our labs can be found in our web site also.



APPENDIX-A

MODIFICATIONS RECORDERS FOR ENGINEERING CHANGES TO THE EUT BY THE LAB

No any modifications are made to the EUT by the lab during the test.