

**APPENDIX A: TEST DATA**  
**Liquid Level Photo**

**MSL 2450MHz D=151mm**



Test Laboratory: Advance Data Technology

## N800C-11b-Ch1-Mode 1

**DUT: N1 Wireless Notebook Card ; Type: F5D8011 v3000 ; Test Frequency: 2412 MHz**

Communication System: 802.11b ; Frequency: 2412 MHz ; Duty Cycle: 1:1 ; Modulation type: DBPSK  
 Medium: MSL2450 Medium parameters used:  $f = 2412$  MHz;  $\sigma = 1.93$  mho/m;  $\epsilon_r = 52.3$ ;  $\rho = 1000$  kg/m<sup>3</sup> ; Liquid level : 151 mm  
 Phantom section: Flat Section ; Separation distance : 11 mm (The bottom side of the EUT to the Phantom)  
 Antenna type : Printed Antenna ; Air temp. : 21.4 degrees ; Liquid temp. : 20.3 degrees

DASY4 Configuration:

- Probe: ET3DV6 - SN1790 ; ConvF(4.35, 4.35, 4.35) ; Calibrated: 2006/11/23
- Sensor-Surface: 4mm (Mechanical Surface Detection)
- Electronics: DAE3 Sn579 ; Calibrated: 2006/3/15
- Phantom: SAM 12 ; Type: SAM V4.0 ; Serial: TP 1202
- Measurement SW: DASY4, V4.7 Build 53 ; Postprocessing SW: SEMCAD, V1.8 Build 172

**Low Channel 1/Area Scan (7x10x1):** Measurement grid: dx=15mm, dy=15mm  
 Maximum value of SAR (measured) = 0.390 mW/g

**Low Channel 1/Zoom Scan (7x7x7) (7x7x7)/Cube 0:** Measurement grid: dx=5mm, dy=5mm, dz=5mm

Reference Value = 12.90 V/m

Peak SAR (extrapolated) = 0.891 W/kg

**SAR(1 g) = 0.405 mW/g; SAR(10 g) = 0.211 mW/g**

Maximum value of SAR (measured) = 0.426 mW/g

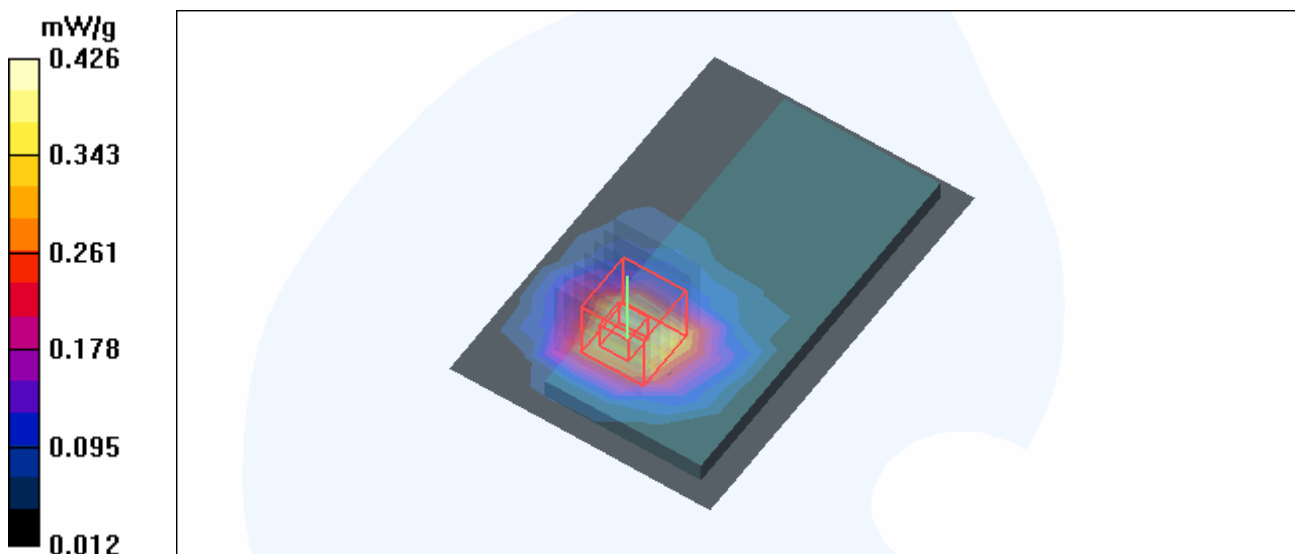

Test Laboratory: Advance Data Technology

## N800C-11b-Ch6-Mode 1

**DUT: N1 Wireless Notebook Card ; Type: F5D8011 v3000 ; Test Frequency: 2437 MHz**

Communication System: 802.11b ; Frequency: 2437 MHz ; Duty Cycle: 1:1 ; Modulation type: DBPSK  
Medium: MSL2450 Medium parameters used:  $f = 2437$  MHz;  $\sigma = 1.96$  mho/m;  $\epsilon_r = 52.2$ ;  $\rho = 1000$  kg/m<sup>3</sup> ; Liquid level : 151 mm  
Phantom section: Flat Section ; Separation distance : 11 mm (The bottom side of the EUT to the Phantom)  
Antenna type : Printed Antenna ; Air temp. : 21.4 degrees ; Liquid temp. : 20.3 degrees

DASY4 Configuration:

- Probe: ET3DV6 - SN1790 ; ConvF(4.35, 4.35, 4.35) ; Calibrated: 2006/11/23
- Sensor-Surface: 4mm (Mechanical Surface Detection)
- Electronics: DAE3 Sn579 ; Calibrated: 2006/3/15
- Phantom: SAM 12 ; Type: SAM V4.0 ; Serial: TP 1202
- Measurement SW: DASY4, V4.7 Build 53 ; Postprocessing SW: SEMCAD, V1.8 Build 172

**Mid Channel 6/Area Scan (7x10x1):** Measurement grid: dx=15mm, dy=15mm  
Maximum value of SAR (measured) = 0.367 mW/g

**Mid Channel 6/Zoom Scan (7x7x7) (7x7x7)/Cube 0:** Measurement grid: dx=5mm, dy=5mm, dz=5mm  
Reference Value = 12.10 V/m  
Peak SAR (extrapolated) = 0.905 W/kg  
**SAR(1 g) = 0.394 mW/g; SAR(10 g) = 0.201 mW/g**  
Maximum value of SAR (measured) = 0.419 mW/g

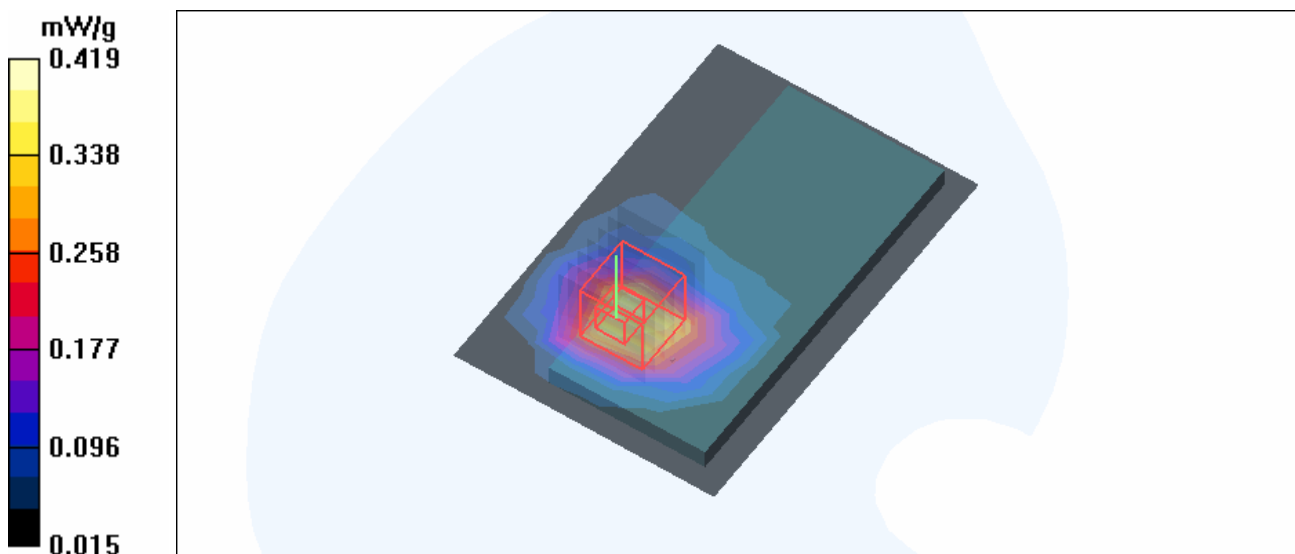

Test Laboratory: Advance Data Technology

## N800C-11b-Ch11-Mode 1

**DUT: N1 Wireless Notebook Card ; Type: F5D8011 v3000 ; Test Frequency: 2462 MHz**

Communication System: 802.11b ; Frequency: 2462 MHz ; Duty Cycle: 1:1 ; Modulation type: DBPSK  
 Medium: MSL2450 Medium parameters used:  $f = 2462$  MHz;  $\sigma = 2$  mho/m;  $\epsilon_r = 52.1$ ;  $\rho = 1000$  kg/m<sup>3</sup> ; Liquid level : 151 mm  
 Phantom section: Flat Section ; Separation distance : 11 mm (The bottom side of the EUT to the Phantom)  
 Antenna type : Printed Antenna ; Air temp. : 21.4 degrees ; Liquid temp. : 20.3 degrees

DASY4 Configuration:

- Probe: ET3DV6 - SN1790 ; ConvF(4.35, 4.35, 4.35) ; Calibrated: 2006/11/23
- Sensor-Surface: 4mm (Mechanical Surface Detection)
- Electronics: DAE3 Sn579 ; Calibrated: 2006/3/15
- Phantom: SAM 12 ; Type: SAM V4.0 ; Serial: TP 1202
- Measurement SW: DASY4, V4.7 Build 53 ; Postprocessing SW: SEMCAD, V1.8 Build 172

**High Channel 11/Area Scan (7x10x1):** Measurement grid: dx=15mm, dy=15mm  
 Maximum value of SAR (measured) = 0.390 mW/g

**High Channel 11/Zoom Scan (7x7x7) (7x7x7)/Cube 0:** Measurement grid: dx=5mm, dy=5mm, dz=5mm

Reference Value = 13.67 V/m

Peak SAR (extrapolated) = 0.969 W/kg

**SAR(1 g) = 0.417 mW/g; SAR(10 g) = 0.219 mW/g**

Maximum value of SAR (measured) = 0.442 mW/g

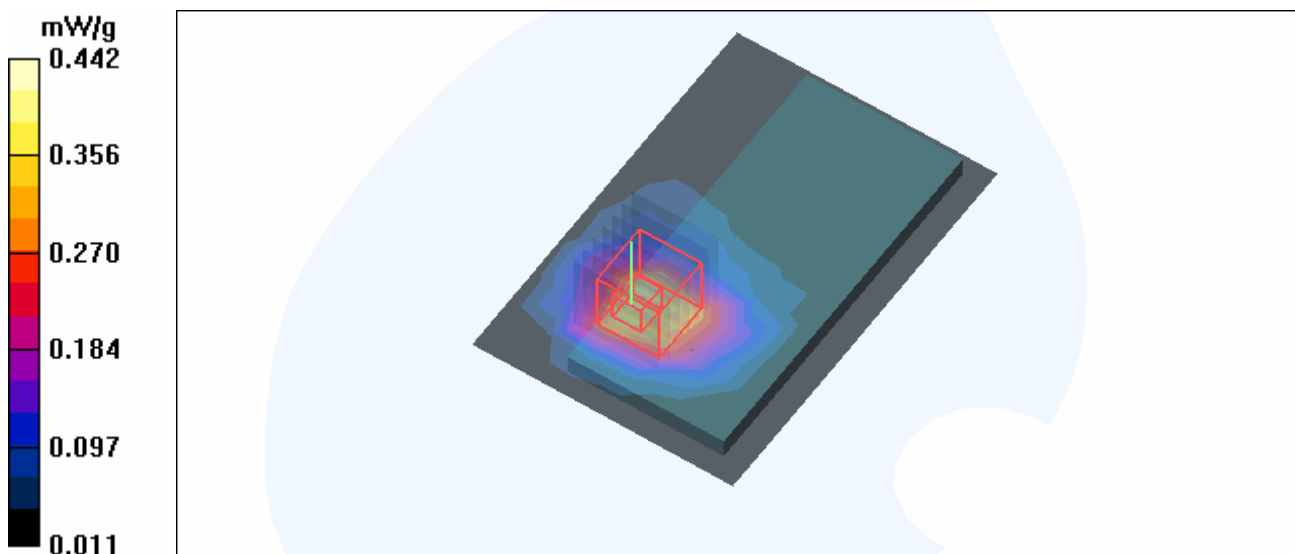

Test Laboratory: Advance Data Technology

## N800C-11g-Ch1-Mode 2

**DUT: N1 Wireless Notebook Card ; Type: F5D8011 v3000 ; Test Frequency: 2412 MHz**

Communication System: 802.11g ; Frequency: 2412 MHz ; Duty Cycle: 1:1 ; Modulation type: BPSK  
Medium: MSL2450 Medium parameters used:  $f = 2412$  MHz;  $\sigma = 1.93$  mho/m;  $\epsilon_r = 52.3$ ;  $\rho = 1000$  kg/m<sup>3</sup> ; Liquid level : 151 mm

Phantom section: Flat Section ; Separation distance : 11 mm (The bottom side of the EUT to the Phantom)  
Antenna type : Printed Antenna ; Air temp. : 21.4 degrees ; Liquid temp. : 20.3 degrees

DASY4 Configuration:

- Probe: ET3DV6 - SN1790 ; ConvF(4.35, 4.35, 4.35) ; Calibrated: 2006/11/23
- Sensor-Surface: 4mm (Mechanical Surface Detection)
- Electronics: DAE3 Sn579 ; Calibrated: 2006/3/15
- Phantom: SAM 12 ; Type: SAM V4.0 ; Serial: TP 1202
- Measurement SW: DASY4, V4.7 Build 53 ; Postprocessing SW: SEMCAD, V1.8 Build 172

**Low Channel 1/Area Scan (7x10x1):** Measurement grid: dx=15mm, dy=15mm  
Maximum value of SAR (measured) = 0.355 mW/g

**Low Channel 1/Zoom Scan (7x7x7) (7x7x7)/Cube 0:** Measurement grid: dx=5mm, dy=5mm, dz=5mm

Reference Value = 12.0 V/m

Peak SAR (extrapolated) = 0.847 W/kg

**SAR(1 g) = 0.382 mW/g; SAR(10 g) = 0.208 mW/g**

Maximum value of SAR (measured) = 0.402 mW/g

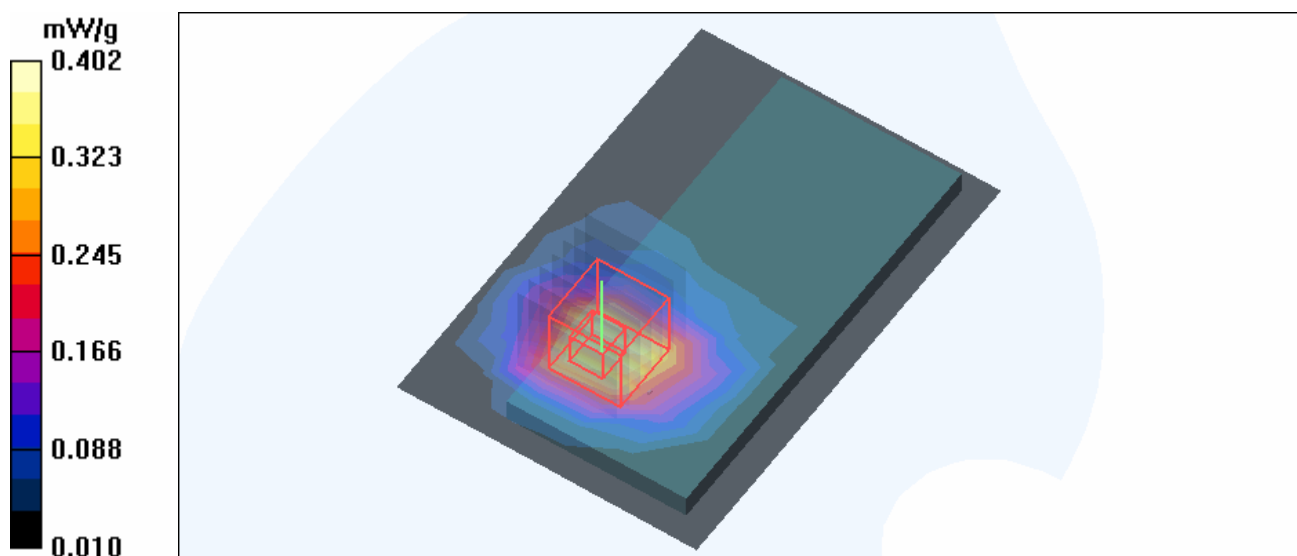

Test Laboratory: Advance Data Technology

## N800C-11g-Ch6-Mode 2

**DUT: N1 Wireless Notebook Card ; Type: F5D8011 v3000 ; Test Frequency: 2437 MHz**

Communication System: 802.11g ; Frequency: 2437 MHz ; Duty Cycle: 1:1 ; Modulation type: BPSK  
 Medium: MSL2450 Medium parameters used:  $f = 2437 \text{ MHz}$ ;  $\sigma = 1.96 \text{ mho/m}$ ;  $\epsilon_r = 52.2$ ;  $\rho = 1000 \text{ kg/m}^3$  ; Liquid level : 151 mm

Phantom section: Flat Section ; Separation distance : 11 mm (The bottom side of the EUT to the Phantom)  
 Antenna type : Printed Antenna ; Air temp. : 21.4 degrees ; Liquid temp. : 20.3 degrees

DASY4 Configuration:

- Probe: ET3DV6 - SN1790 ; ConvF(4.35, 4.35, 4.35) ; Calibrated: 2006/11/23
- Sensor-Surface: 4mm (Mechanical Surface Detection)
- Electronics: DAE3 Sn579 ; Calibrated: 2006/3/15
- Phantom: SAM 12 ; Type: SAM V4.0 ; Serial: TP 1202
- Measurement SW: DASY4, V4.7 Build 53 ; Postprocessing SW: SEMCAD, V1.8 Build 172

**Mid Channel 6/Area Scan (7x10x1):** Measurement grid:  $dx=15\text{mm}$ ,  $dy=15\text{mm}$

Maximum value of SAR (measured) = 0.347 mW/g

**Mid Channel 6/Zoom Scan (7x7x7) (7x7x7)/Cube 0:** Measurement grid:  $dx=5\text{mm}$ ,  $dy=5\text{mm}$ ,  $dz=5\text{mm}$

Reference Value = 11.91 V/m

Peak SAR (extrapolated) = 0.855 W/kg

**SAR(1 g) = 0.376 mW/g; SAR(10 g) = 0.202 mW/g**

Maximum value of SAR (measured) = 0.396 mW/g

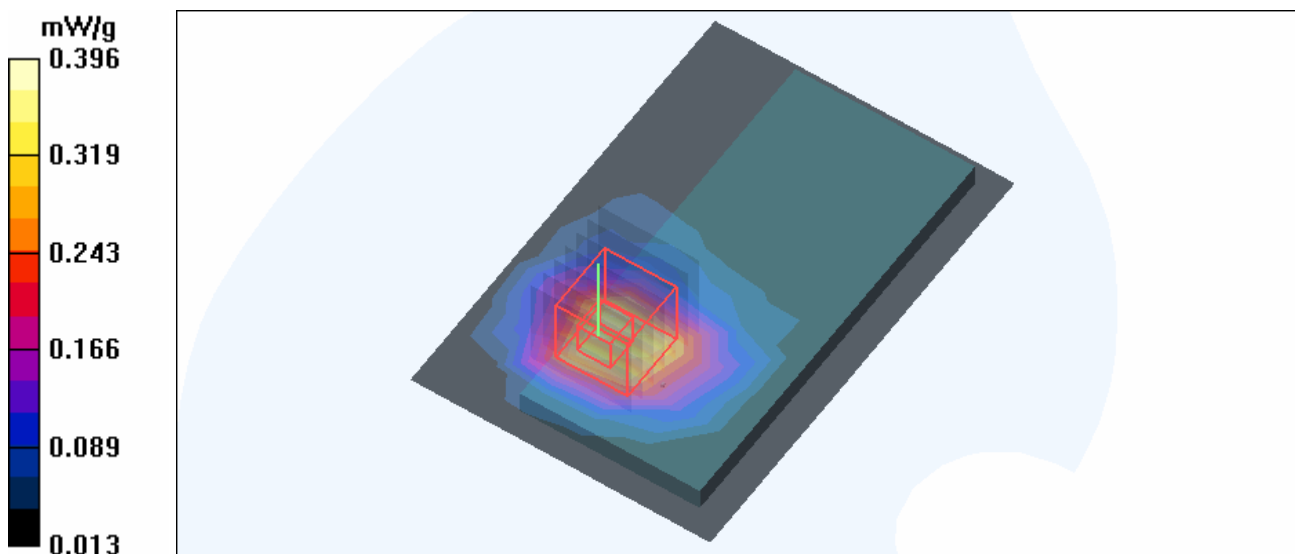

Test Laboratory: Advance Data Technology

## N800C-11g-Ch11-Mode 2

**DUT: N1 Wireless Notebook Card ; Type: F5D8011 v3000 ; Test Frequency: 2462 MHz**

Communication System: 802.11g ; Frequency: 2462 MHz ; Duty Cycle: 1:1 ; Modulation type: BPSK  
 Medium: MSL2450 Medium parameters used:  $f = 2462$  MHz;  $\sigma = 2$  mho/m;  $\epsilon_r = 52.1$ ;  $\rho = 1000$  kg/m<sup>3</sup> ; Liquid level : 151 mm

Phantom section: Flat Section ; Separation distance : 11 mm (The bottom side of the EUT to the Phantom)  
 Antenna type : Printed Antenna ; Air temp. : 21.4 degrees ; Liquid temp. : 20.3 degrees

DASY4 Configuration:

- Probe: ET3DV6 - SN1790 ; ConvF(4.35, 4.35, 4.35) ; Calibrated: 2006/11/23
- Sensor-Surface: 4mm (Mechanical Surface Detection)
- Electronics: DAE3 Sn579 ; Calibrated: 2006/3/15
- Phantom: SAM 12 ; Type: SAM V4.0 ; Serial: TP 1202
- Measurement SW: DASY4, V4.7 Build 53 ; Postprocessing SW: SEMCAD, V1.8 Build 172

**High Channel 11/Area Scan (7x10x1):** Measurement grid: dx=15mm, dy=15mm  
 Maximum value of SAR (measured) = 0.327 mW/g

**High Channel 11/Zoom Scan (7x7x7) (7x7x7)/Cube 0:** Measurement grid: dx=5mm, dy=5mm, dz=5mm

Reference Value = 11.04 V/m

Peak SAR (extrapolated) = 0.843 W/kg

**SAR(1 g) = 0.355 mW/g; SAR(10 g) = 0.186 mW/g**

Maximum value of SAR (measured) = 0.374 mW/g

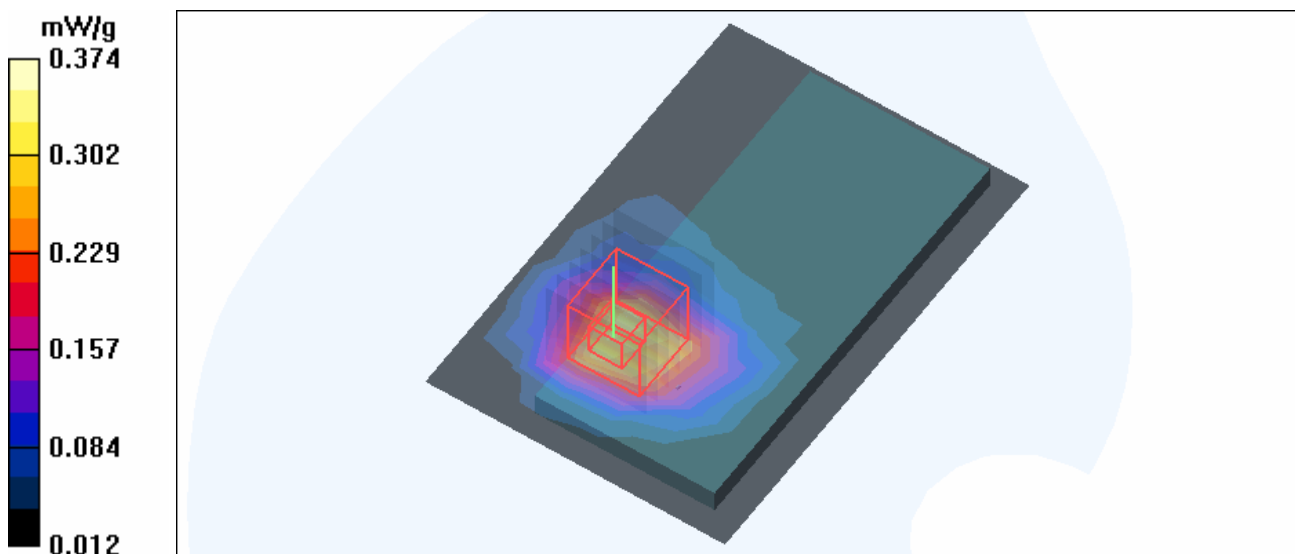

Test Laboratory: Advance Data Technology

### N800C-11n-20M-Ch1-Mode 3

**DUT: N1 Wireless Notebook Card ; Type: F5D8011 v3000 ; Test Frequency: 2412 MHz**

Communication System: 802.11n ; Frequency: 2412 MHz ; Duty Cycle: 1:1 ; Modulation type: BPSK  
 Medium: MSL2450 Medium parameters used:  $f = 2412$  MHz;  $\sigma = 1.93$  mho/m;  $\epsilon_r = 52.3$ ;  $\rho = 1000$  kg/m<sup>3</sup> ; Liquid level : 151 mm

Phantom section: Flat Section ; Separation distance : 11 mm (The bottom side of the EUT to the Phantom)  
 Antenna type : Printed Antenna ; Air temp. : 21.4 degrees ; Liquid temp. : 20.3 degrees

DASY4 Configuration:

- Probe: ET3DV6 - SN1790 ; ConvF(4.35, 4.35, 4.35) ; Calibrated: 2006/11/23
- Sensor-Surface: 4mm (Mechanical Surface Detection)
- Electronics: DAE3 Sn579 ; Calibrated: 2006/3/15
- Phantom: SAM 12 ; Type: SAM V4.0 ; Serial: TP 1202
- Measurement SW: DASY4, V4.7 Build 53 ; Postprocessing SW: SEMCAD, V1.8 Build 172

**Low Channel 1/Area Scan (7x10x1):** Measurement grid: dx=15mm, dy=15mm  
 Maximum value of SAR (measured) = 0.378 mW/g

**Low Channel 1/Zoom Scan (7x7x7) (7x7x7)/Cube 0:** Measurement grid: dx=5mm, dy=5mm, dz=5mm

Reference Value = 13.96 V/m

Peak SAR (extrapolated) = 0.876 W/kg

**SAR(1 g) = 0.415 mW/g; SAR(10 g) = 0.219 mW/g**

Maximum value of SAR (measured) = 0.442 mW/g

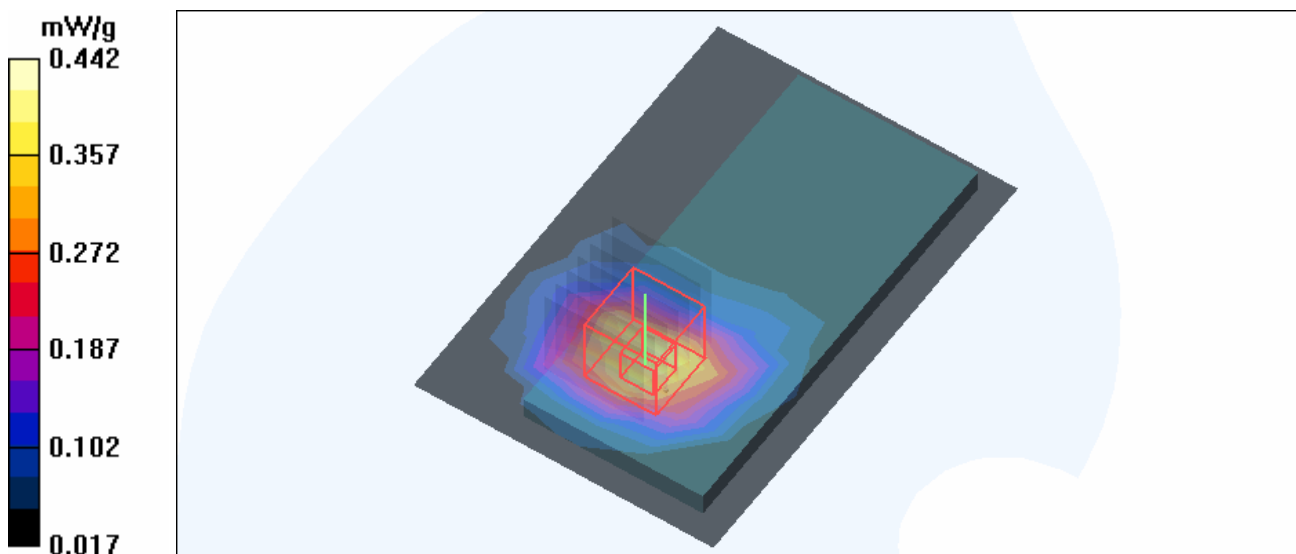



Test Laboratory: Advance Data Technology

### N800C-11n-20M-Ch6-Mode 3

**DUT: N1 Wireless Notebook Card ; Type: F5D8011 v3000 ; Test Frequency: 2437 MHz**

Communication System: 802.11n ; Frequency: 2437 MHz ; Duty Cycle: 1:1 ; Modulation type: BPSK  
 Medium: MSL2450 Medium parameters used:  $f = 2437 \text{ MHz}$ ;  $\sigma = 1.96 \text{ mho/m}$ ;  $\epsilon_r = 52.2$ ;  $\rho = 1000 \text{ kg/m}^3$  ; Liquid level : 151 mm

Phantom section: Flat Section ; Separation distance : 11 mm (The bottom side of the EUT to the Phantom)  
 Antenna type : Printed Antenna ; Air temp. : 21.4 degrees ; Liquid temp. : 20.3 degrees

DASY4 Configuration:

- Probe: ET3DV6 - SN1790 ; ConvF(4.35, 4.35, 4.35) ; Calibrated: 2006/11/23
- Sensor-Surface: 4mm (Mechanical Surface Detection)
- Electronics: DAE3 Sn579 ; Calibrated: 2006/3/15
- Phantom: SAM 12 ; Type: SAM V4.0 ; Serial: TP 1202
- Measurement SW: DASY4, V4.7 Build 53 ; Postprocessing SW: SEMCAD, V1.8 Build 172

**Mid Channel 6/Area Scan (7x10x1):** Measurement grid:  $dx=15\text{mm}$ ,  $dy=15\text{mm}$   
 Maximum value of SAR (measured) = 0.361 mW/g

**Mid Channel 6/Zoom Scan (7x7x7) (7x7x7)/Cube 0:** Measurement grid:  $dx=5\text{mm}$ ,  $dy=5\text{mm}$ ,  $dz=5\text{mm}$

Reference Value = 13.96 V/m

Peak SAR (extrapolated) = 0.893 W/kg

**SAR(1 g) = 0.406 mW/g; SAR(10 g) = 0.215 mW/g**

Maximum value of SAR (measured) = 0.427 mW/g

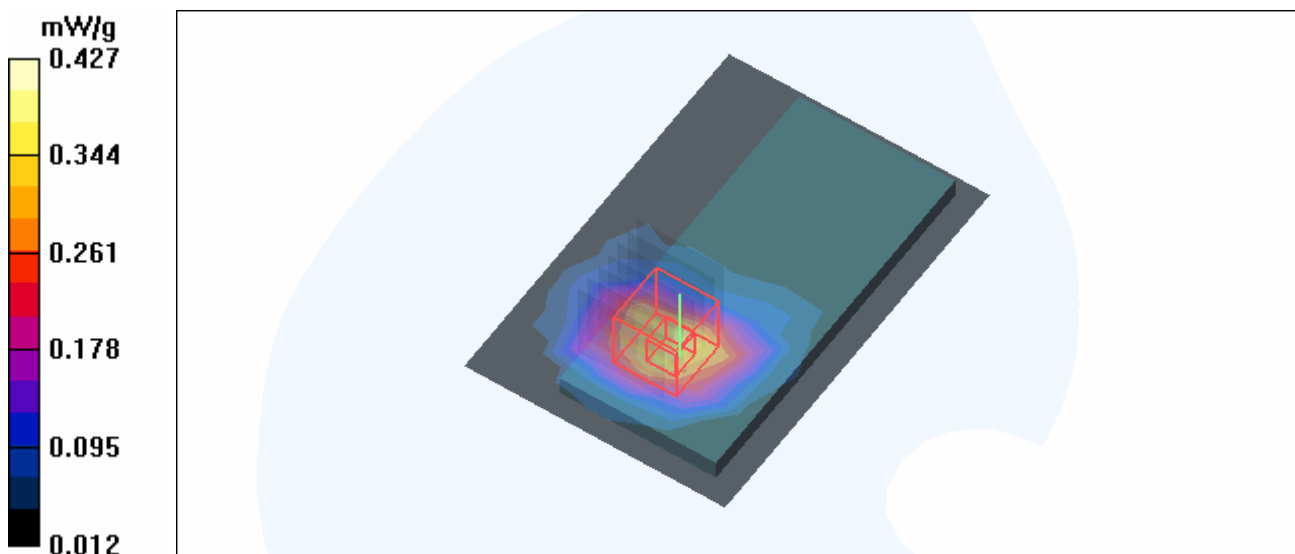

Test Laboratory: Advance Data Technology

### N800C-11n-20M-Ch11-Mode 3

**DUT: N1 Wireless Notebook Card ; Type: F5D8011 v3000 ; Test Frequency: 2462 MHz**

Communication System: 802.11n ; Frequency: 2462 MHz ; Duty Cycle: 1:1 ; Modulation type: BPSK  
 Medium: MSL2450 Medium parameters used:  $f = 2462$  MHz;  $\sigma = 2$  mho/m;  $\epsilon_r = 52.1$ ;  $\rho = 1000$  kg/m<sup>3</sup> ; Liquid level : 151 mm

Phantom section: Flat Section ; Separation distance : 11 mm (The bottom side of the EUT to the Phantom)  
 Antenna type : Printed Antenna ; Air temp. : 21.4 degrees ; Liquid temp. : 20.3 degrees

DASY4 Configuration:

- Probe: ET3DV6 - SN1790 ; ConvF(4.35, 4.35, 4.35) ; Calibrated: 2006/11/23
- Sensor-Surface: 4mm (Mechanical Surface Detection)
- Electronics: DAE3 Sn579 ; Calibrated: 2006/3/15
- Phantom: SAM 12 ; Type: SAM V4.0 ; Serial: TP 1202
- Measurement SW: DASY4, V4.7 Build 53 ; Postprocessing SW: SEMCAD, V1.8 Build 172

**High Channel 11/Area Scan (7x10x1):** Measurement grid: dx=15mm, dy=15mm  
 Maximum value of SAR (measured) = 0.373 mW/g

**High Channel 11/Zoom Scan (7x7x7) (7x7x7)/Cube 0:** Measurement grid: dx=5mm, dy=5mm, dz=5mm

Reference Value = 14.3 V/m

Peak SAR (extrapolated) = 0.944 W/kg

**SAR(1 g) = 0.425 mW/g; SAR(10 g) = 0.224 mW/g**

Maximum value of SAR (measured) = 0.449 mW/g

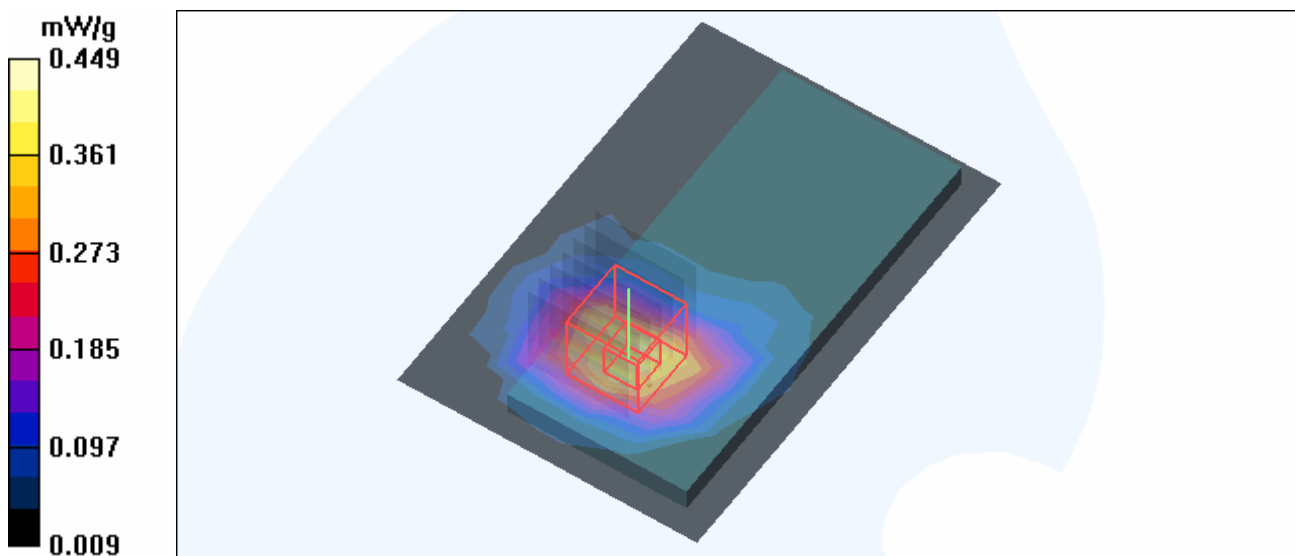

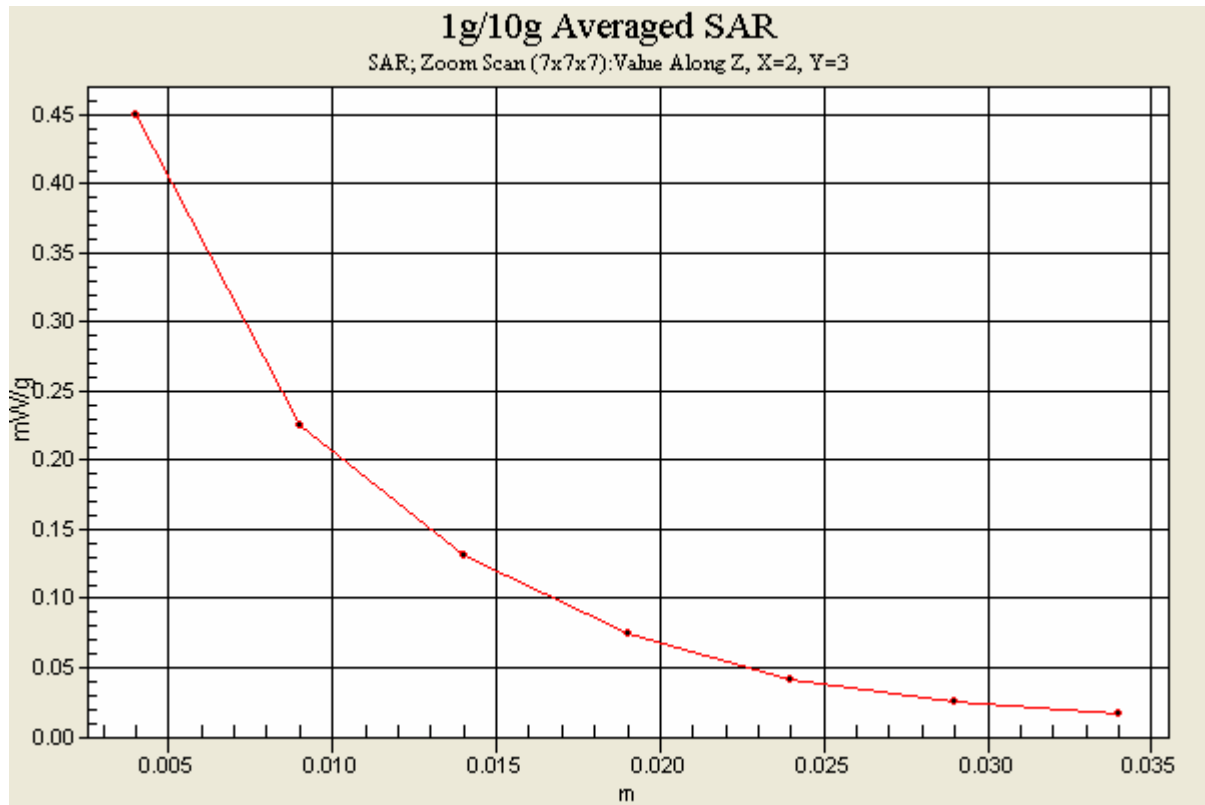

Test Laboratory: Advance Data Technology

## N800C-11n-40M-Ch1-Mode 4

**DUT: N1 Wireless Notebook Card ; Type: F5D8011 v3000 ; Test Frequency: 2422 MHz**

Communication System: 802.11n ; Frequency: 2422 MHz ; Duty Cycle: 1:1 ; Modulation type: BPSK  
 Medium: MSL2450 Medium parameters used :  $f = 2422$  MHz;  $\sigma = 1.94$  mho/m;  $\epsilon_r = 52.3$ ;  $\rho = 1000$  kg/m<sup>3</sup> ; Liquid level : 151 mm

Phantom section: Flat Section ; Separation distance : 11 mm (The bottom side of the EUT to the Phantom)  
 Antenna type : Printed Antenna ; Air temp. : 21.4 degrees ; Liquid temp. : 20.3 degrees

DASY4 Configuration:

- Probe: ET3DV6 - SN1790 ; ConvF(4.35, 4.35, 4.35) ; Calibrated: 2006/11/23
- Sensor-Surface: 4mm (Mechanical Surface Detection)
- Electronics: DAE3 Sn579 ; Calibrated: 2006/3/15
- Phantom: SAM 12 ; Type: SAM V4.0 ; Serial: TP 1202
- Measurement SW: DASY4, V4.7 Build 53 ; Postprocessing SW: SEMCAD, V1.8 Build 172

**Low Channel 1/Area Scan (7x10x1):** Measurement grid: dx=15mm, dy=15mm  
 Maximum value of SAR (measured) = 0.066 mW/g

**Low Channel 1/Zoom Scan (7x7x7) (7x7x7)/Cube 0:** Measurement grid: dx=5mm, dy=5mm, dz=5mm

Reference Value = 6.12 V/m

Peak SAR (extrapolated) = 0.152 W/kg

**SAR(1 g) = 0.072 mW/g; SAR(10 g) = 0.039 mW/g**

Maximum value of SAR (measured) = 0.076 mW/g

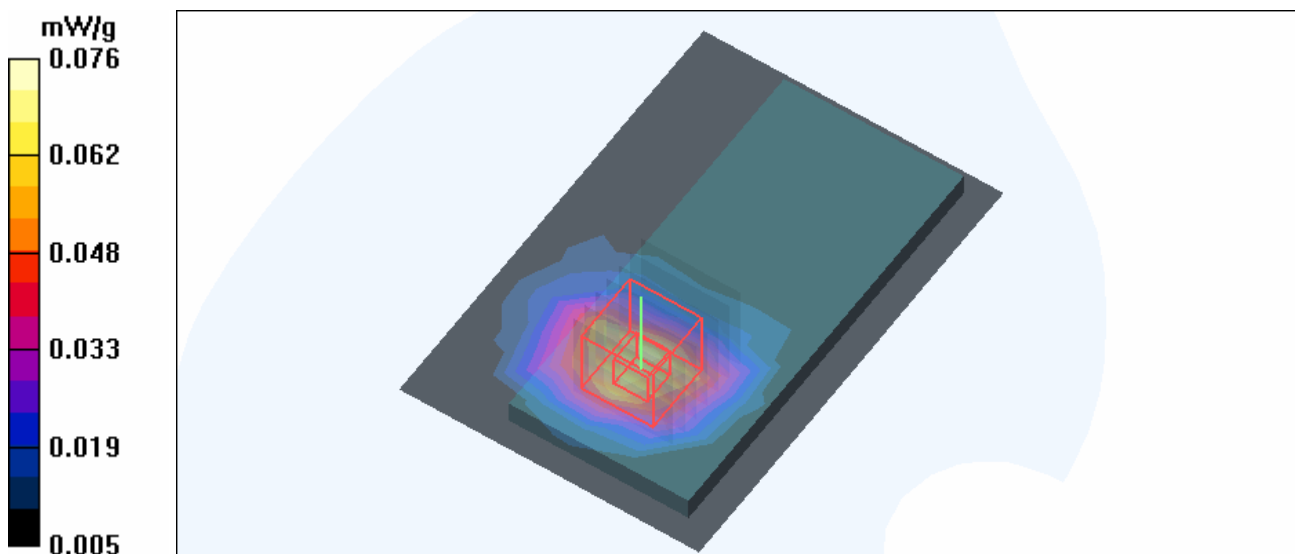

Test Laboratory: Advance Data Technology

## N800C-11n-40M-Ch4-Mode 4

**DUT: N1 Wireless Notebook Card ; Type: F5D8011 v3000 ; Test Frequency: 2437 MHz**

Communication System: 802.11n ; Frequency: 2437 MHz ; Duty Cycle: 1:1 ; Modulation type: BPSK  
 Medium: MSL2450 Medium parameters used:  $f = 2437$  MHz;  $\sigma = 1.96$  mho/m;  $\epsilon_r = 52.2$ ;  $\rho = 1000$  kg/m<sup>3</sup> ; Liquid level : 151 mm

Phantom section: Flat Section ; Separation distance : 11 mm (The bottom side of the EUT to the Phantom)  
 Antenna type : Printed Antenna ; Air temp. : 21.4 degrees ; Liquid temp. : 20.3 degrees

DASY4 Configuration:

- Probe: ET3DV6 - SN1790 ; ConvF(4.35, 4.35, 4.35) ; Calibrated: 2006/11/23
- Sensor-Surface: 4mm (Mechanical Surface Detection)
- Electronics: DAE3 Sn579 ; Calibrated: 2006/3/15
- Phantom: SAM 12 ; Type: SAM V4.0 ; Serial: TP 1202
- Measurement SW: DASY4, V4.7 Build 53 ; Postprocessing SW: SEMCAD, V1.8 Build 172

**Mid Channel 4/Area Scan (7x10x1):** Measurement grid: dx=15mm, dy=15mm  
 Maximum value of SAR (measured) = 0.057 mW/g

**Mid Channel 4/Zoom Scan (7x7x7) (7x7x7)/Cube 0:** Measurement grid: dx=5mm, dy=5mm, dz=5mm

Reference Value = 5.62 V/m

Peak SAR (extrapolated) = 0.144 W/kg

**SAR(1 g) = 0.064 mW/g; SAR(10 g) = 0.035 mW/g**

Maximum value of SAR (measured) = 0.067 mW/g

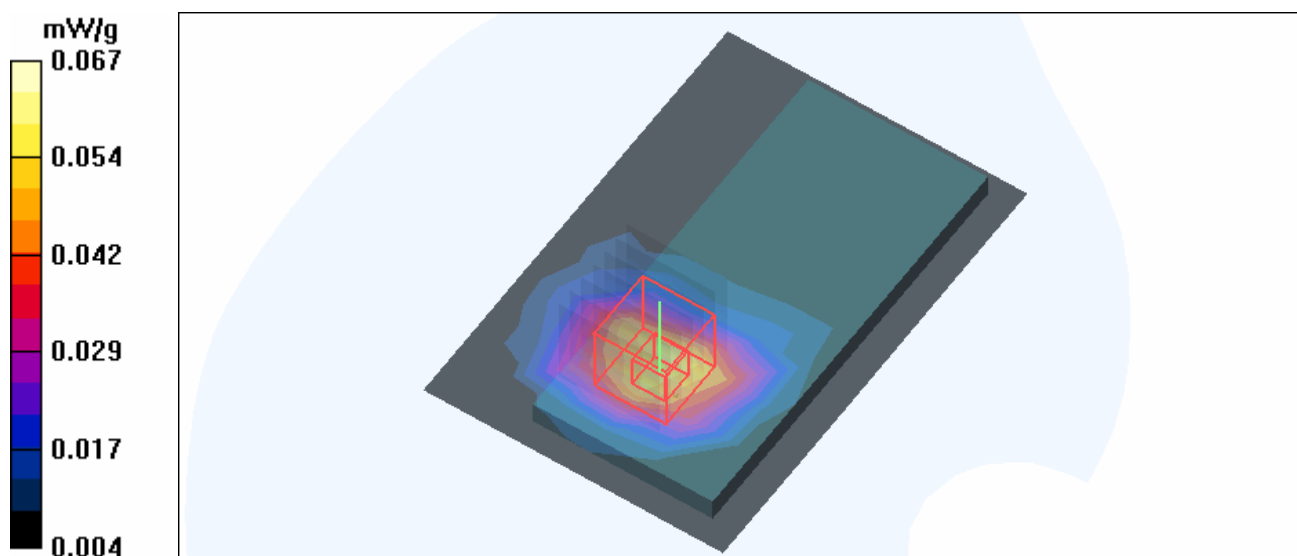

Test Laboratory: Advance Data Technology

## N800C-11n-40M-Ch7-Mode 4

**DUT: N1 Wireless Notebook Card ; Type: F5D8011 v3000 ; Test Frequency: 2452 MHz**

Communication System: 802.11n ; Frequency: 2452 MHz ; Duty Cycle: 1:1 ; Modulation type: BPSK  
Medium: MSL2450 Medium parameters used :  $f = 2452$  MHz;  $\sigma = 1.98$  mho/m;  $\epsilon_r = 52.1$ ;  $\rho = 1000$  kg/m<sup>3</sup> ; Liquid level : 151 mm

Phantom section: Flat Section ; Separation distance : 11 mm (The bottom side of the EUT to the Phantom)  
Antenna type : Printed Antenna ; Air temp. : 21.4 degrees ; Liquid temp. : 20.3 degrees

DASY4 Configuration:

- Probe: ET3DV6 - SN1790 ; ConvF(4.35, 4.35, 4.35) ; Calibrated: 2006/11/23
- Sensor-Surface: 4mm (Mechanical Surface Detection)
- Electronics: DAE3 Sn579 ; Calibrated: 2006/3/15
- Phantom: SAM 12 ; Type: SAM V4.0 ; Serial: TP 1202
- Measurement SW: DASY4, V4.7 Build 53 ; Postprocessing SW: SEMCAD, V1.8 Build 172

**High Channel 7/Area Scan (7x10x1):** Measurement grid: dx=15mm, dy=15mm  
Maximum value of SAR (measured) = 0.055 mW/g

**High Channel 7/Zoom Scan (7x7x7) (7x7x7)/Cube 0:** Measurement grid: dx=5mm, dy=5mm, dz=5mm

Reference Value = 5.49 V/m

Peak SAR (extrapolated) = 0.151 W/kg

**SAR(1 g) = 0.065 mW/g; SAR(10 g) = 0.036 mW/g**

Maximum value of SAR (measured) = 0.067 mW/g

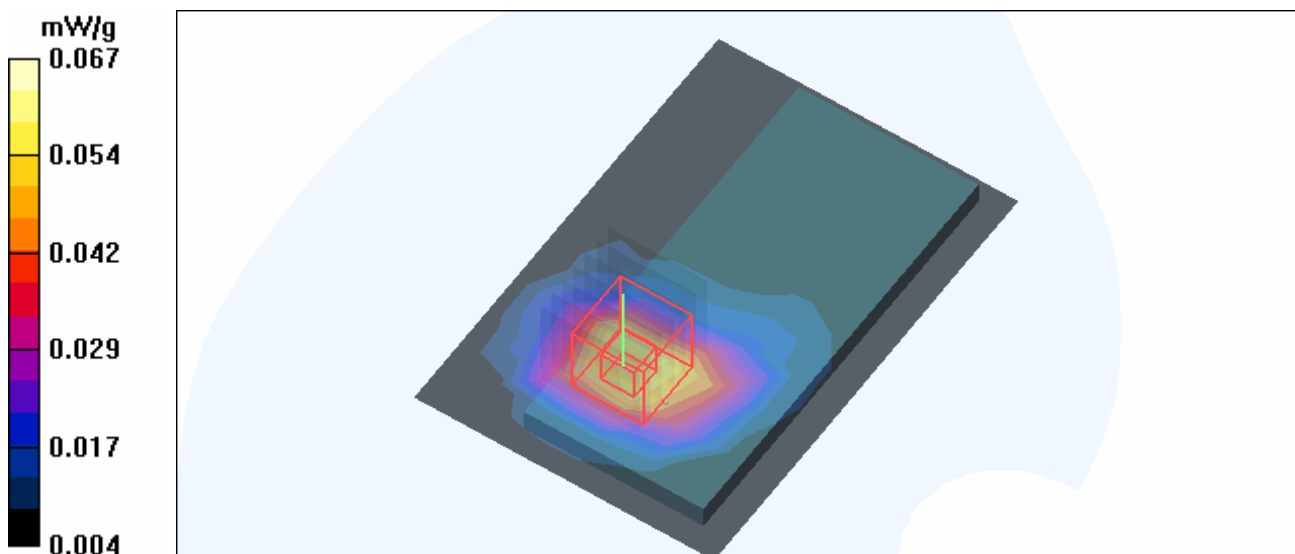

Test Laboratory: Advance Data Technology

**C600-11b-Ch11-Mode 5****DUT: N1 Wireless Notebook Card ; Type: F5D8011 v3000 ; Test Frequency: 2462 MHz**

Communication System: 802.11b ; Frequency: 2462 MHz ; Duty Cycle: 1:1 ; Modulation type: DBPSK  
Medium: MSL2450 Medium parameters used:  $f = 2462$  MHz;  $\sigma = 2$  mho/m;  $\epsilon_r = 52.1$ ;  $\rho = 1000$  kg/m<sup>3</sup> ; Liquid level : 151 mm  
Phantom section: Flat Section ; Separation distance : 12 mm (The bottom side of the EUT to the Phantom)  
Antenna type : Printed Antenna ; Air temp. : 21.4 degrees ; Liquid temp. : 20.3 degrees

DASY4 Configuration:

- Probe: ET3DV6 - SN1790 ; ConvF(4.35, 4.35, 4.35) ; Calibrated: 2006/11/23
- Sensor-Surface: 4mm (Mechanical Surface Detection)
- Electronics: DAE3 Sn579 ; Calibrated: 2006/3/15
- Phantom: SAM 12 ; Type: SAM V4.0 ; Serial: TP 1202
- Measurement SW: DASY4, V4.7 Build 53 ; Postprocessing SW: SEMCAD, V1.8 Build 172

**High Channel 11/Area Scan (7x10x1):** Measurement grid: dx=15mm, dy=15mm  
Maximum value of SAR (measured) = 0.378 mW/g

**High Channel 11/Zoom Scan (7x7x7) (7x7x7)/Cube 0:** Measurement grid: dx=5mm, dy=5mm, dz=5mm

Reference Value = 11.0 V/m

Peak SAR (extrapolated) = 0.800 W/kg

**SAR(1 g) = 0.365 mW/g; SAR(10 g) = 0.196 mW/g**

Maximum value of SAR (measured) = 0.384 mW/g

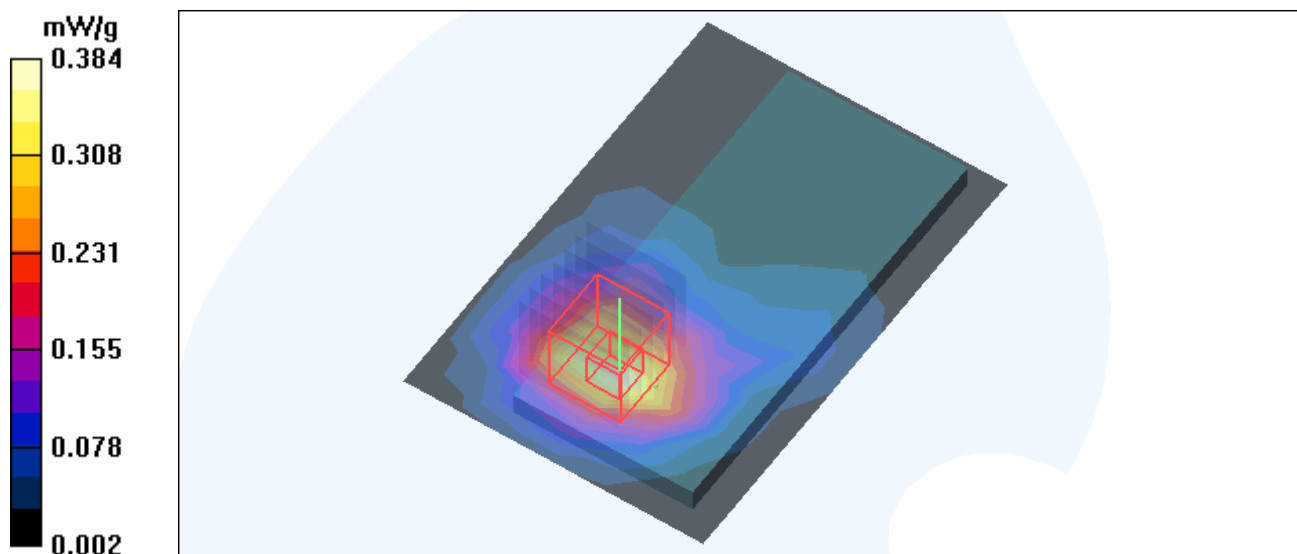

Test Laboratory: Advance Data Technology

## C600-11g-Ch1-Mode 6

**DUT: N1 Wireless Notebook Card ; Type: F5D8011 v3000 ; Test Frequency: 2412 MHz**

Communication System: 802.11g ; Frequency: 2412 MHz ; Duty Cycle: 1:1 ; Modulation type: BPSK  
 Medium: MSL2450 Medium parameters used:  $f = 2412$  MHz;  $\sigma = 1.93$  mho/m;  $\epsilon_r = 52.3$ ;  $\rho = 1000$  kg/m<sup>3</sup> ; Liquid level : 151 mm

Phantom section: Flat Section ; Separation distance : 12 mm (The bottom side of the EUT to the Phantom)  
 Antenna type : Printed Antenna ; Air temp. : 21.4 degrees ; Liquid temp. : 20.3 degrees

DASY4 Configuration:

- Probe: ET3DV6 - SN1790 ; ConvF(4.35, 4.35, 4.35) ; Calibrated: 2006/11/23
- Sensor-Surface: 4mm (Mechanical Surface Detection)
- Electronics: DAE3 Sn579 ; Calibrated: 2006/3/15
- Phantom: SAM 12 ; Type: SAM V4.0 ; Serial: TP 1202
- Measurement SW: DASY4, V4.7 Build 53 ; Postprocessing SW: SEMCAD, V1.8 Build 172

**Low Channel 1/Area Scan (7x10x1):** Measurement grid: dx=15mm, dy=15mm  
 Maximum value of SAR (measured) = 0.320 mW/g

**Low Channel 1/Zoom Scan (7x7x7) (7x7x7)/Cube 0:** Measurement grid: dx=5mm, dy=5mm, dz=5mm

Reference Value = 10.2 V/m

Peak SAR (extrapolated) = 0.718 W/kg

**SAR(1 g) = 0.341 mW/g; SAR(10 g) = 0.184 mW/g**

Maximum value of SAR (measured) = 0.359 mW/g

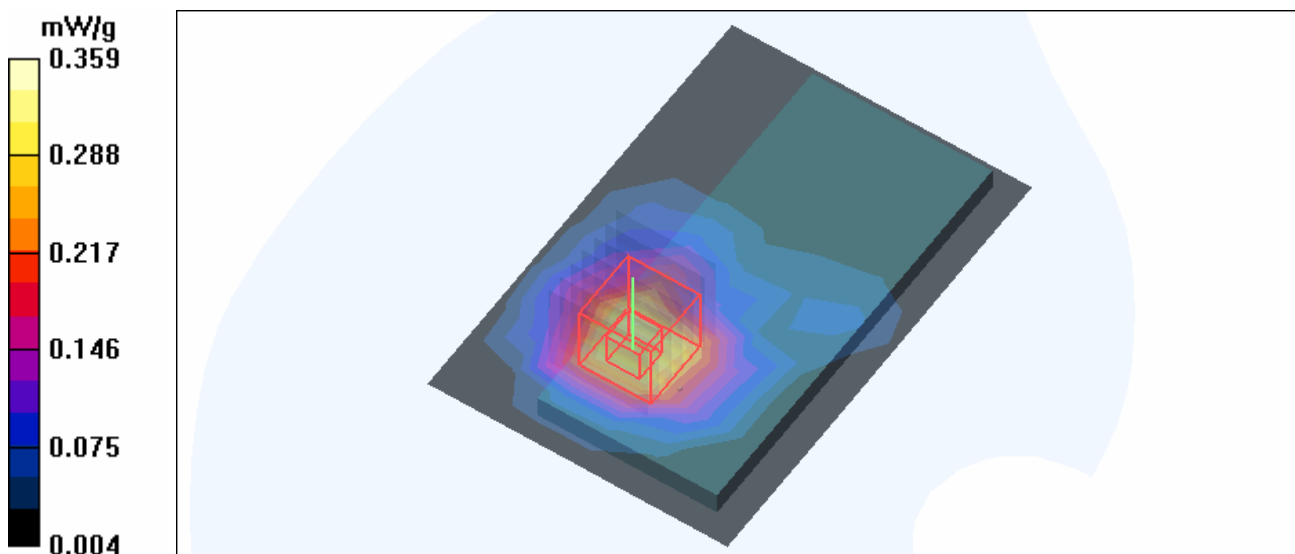



Test Laboratory: Advance Data Technology

### C600-11n-20M-Ch11-Mode 7

**DUT: N1 Wireless Notebook Card ; Type: F5D8011 v3000 ; Test Frequency: 2462 MHz**

Communication System: 802.11n ; Frequency: 2462 MHz ; Duty Cycle: 1:1 ; Modulation type: BPSK  
 Medium: MSL2450 Medium parameters used:  $f = 2462 \text{ MHz}$ ;  $\sigma = 2 \text{ mho/m}$ ;  $\epsilon_r = 52.1$ ;  $\rho = 1000 \text{ kg/m}^3$  ; Liquid level : 151 mm

Phantom section: Flat Section ; Separation distance : 12 mm (The bottom side of the EUT to the Phantom)

Antenna type : Printed Antenna ; Air temp. : 21.4 degrees ; Liquid temp. : 20.3 degrees

DASY4 Configuration:

- Probe: ET3DV6 - SN1790 ; ConvF(4.35, 4.35, 4.35) ; Calibrated: 2006/11/23
- Sensor-Surface: 4mm (Mechanical Surface Detection)
- Electronics: DAE3 Sn579 ; Calibrated: 2006/3/15
- Phantom: SAM 12 ; Type: SAM V4.0 ; Serial: TP 1202
- Measurement SW: DASY4, V4.7 Build 53 ; Postprocessing SW: SEMCAD, V1.8 Build 172

**High Channel 11/Area Scan (7x10x1):** Measurement grid:  $dx=15\text{mm}$ ,  $dy=15\text{mm}$

Maximum value of SAR (measured) = 0.380 mW/g

**High Channel 11/Zoom Scan (7x7x7) (7x7x7)/Cube 0:** Measurement grid:  $dx=5\text{mm}$ ,  $dy=5\text{mm}$ ,  $dz=5\text{mm}$

Reference Value = 11.4 V/m

Peak SAR (extrapolated) = 0.820 W/kg

**SAR(1 g) = 0.386 mW/g; SAR(10 g) = 0.208 mW/g**

Maximum value of SAR (measured) = 0.409 mW/g

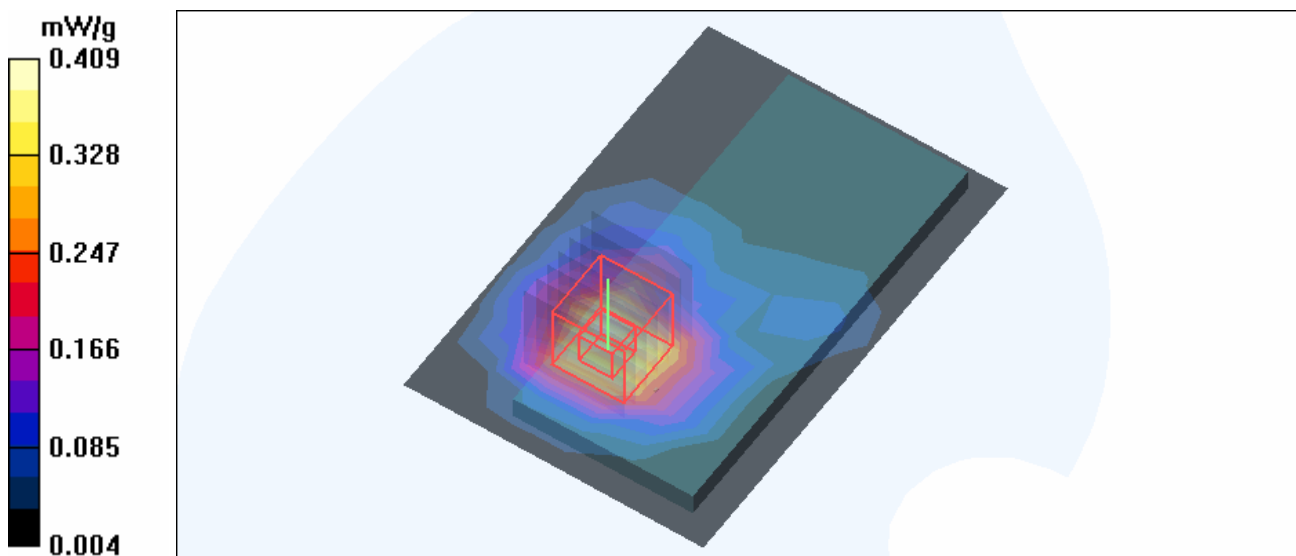

Test Laboratory: Advance Data Technology

### C600-11n-40M-Ch1-Mode 8

**DUT: N1 Wireless Notebook Card ; Type: F5D8011 v3000 ; Test Frequency: 2422 MHz**

Communication System: 802.11n ; Frequency: 2422 MHz ; Duty Cycle: 1:1 ; Modulation type: BPSK  
 Medium: MSL2450 Medium parameters used :  $f = 2422$  MHz;  $\sigma = 1.94$  mho/m;  $\epsilon_r = 52.3$ ;  $\rho = 1000$  kg/m<sup>3</sup> ; Liquid level : 151 mm

Phantom section: Flat Section ; Separation distance : 12 mm (The bottom side of the EUT to the Phantom)  
 Antenna type : Printed Antenna ; Air temp. : 21.4 degrees ; Liquid temp. : 20.3 degrees

DASY4 Configuration:

- Probe: ET3DV6 - SN1790 ; ConvF(4.35, 4.35, 4.35) ; Calibrated: 2006/11/23
- Sensor-Surface: 4mm (Mechanical Surface Detection)
- Electronics: DAE3 Sn579 ; Calibrated: 2006/3/15
- Phantom: SAM 12 ; Type: SAM V4.0 ; Serial: TP 1202
- Measurement SW: DASY4, V4.7 Build 53 ; Postprocessing SW: SEMCAD, V1.8 Build 172

**Low Channel 1/Area Scan (7x10x1):** Measurement grid: dx=15mm, dy=15mm  
 Maximum value of SAR (measured) = 0.064 mW/g

**Low Channel 1/Zoom Scan (7x7x7) (7x7x7)/Cube 0:** Measurement grid: dx=5mm, dy=5mm, dz=5mm

Reference Value = 5.40 V/m

Peak SAR (extrapolated) = 0.135 W/kg

**SAR(1 g) = 0.062 mW/g; SAR(10 g) = 0.033 mW/g**

Maximum value of SAR (measured) = 0.066 mW/g

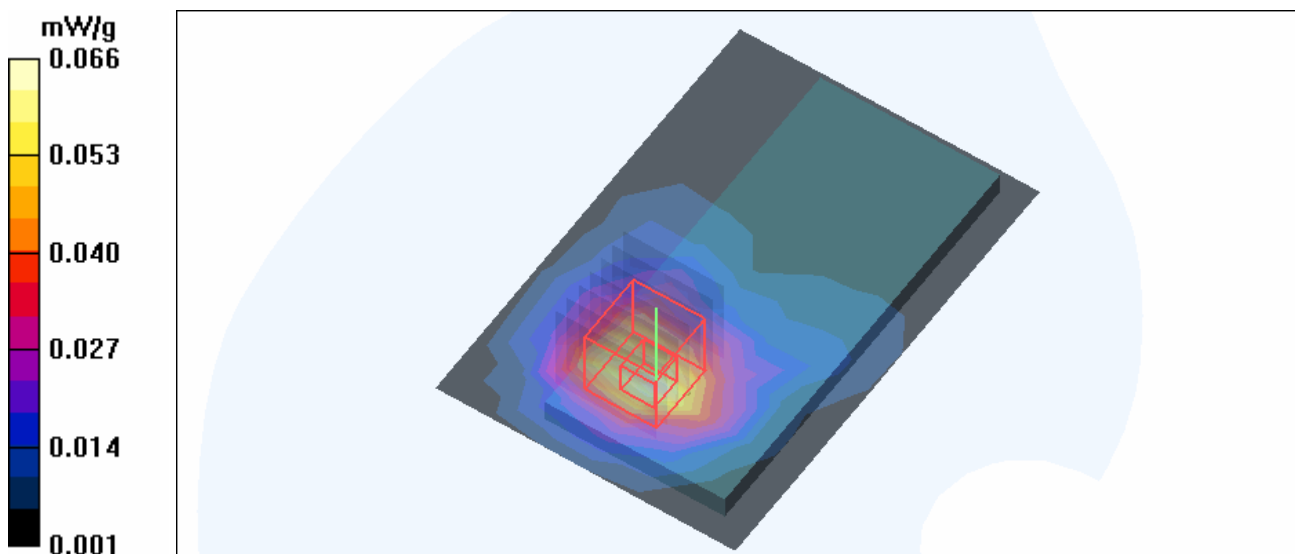

Test Laboratory: Advance Data Technology

## D600-11b-Ch11-Mode 9

**DUT: N1 Wireless Notebook Card ; Type: F5D8011 v3000 ; Test Frequency: 2462 MHz**

Communication System: 802.11b ; Frequency: 2462 MHz ; Duty Cycle: 1:1 ; Modulation type: DBPSK  
 Medium: MSL2450 Medium parameters used:  $f = 2462 \text{ MHz}$ ;  $\sigma = 2 \text{ mho/m}$ ;  $\epsilon_r = 52.1$ ;  $\rho = 1000 \text{ kg/m}^3$  ; Liquid level : 151 mm  
 Phantom section: Flat Section ; Separation distance : 16 mm (The bottom side of the EUT to the Phantom)  
 Antenna type : Printed Antenna ; Air temp. : 21.4 degrees ; Liquid temp. : 20.3 degrees

DASY4 Configuration:

- Probe: ET3DV6 - SN1790 ; ConvF(4.35, 4.35, 4.35) ; Calibrated: 2006/11/23
- Sensor-Surface: 4mm (Mechanical Surface Detection)
- Electronics: DAE3 Sn579 ; Calibrated: 2006/3/15
- Phantom: SAM 12 ; Type: SAM V4.0 ; Serial: TP 1202
- Measurement SW: DASY4, V4.7 Build 53 ; Postprocessing SW: SEMCAD, V1.8 Build 172

**High Channel 11/Area Scan (7x10x1):** Measurement grid:  $dx=15\text{mm}$ ,  $dy=15\text{mm}$   
 Maximum value of SAR (measured) = 0.264 mW/g

**High Channel 11/Zoom Scan (7x7x7) (7x7x7)/Cube 0:** Measurement grid:  $dx=5\text{mm}$ ,  $dy=5\text{mm}$ ,  $dz=5\text{mm}$

Reference Value = 8.35 V/m

Peak SAR (extrapolated) = 0.561 W/kg

**SAR(1 g) = 0.250 mW/g; SAR(10 g) = 0.133 mW/g**

Maximum value of SAR (measured) = 0.262 mW/g

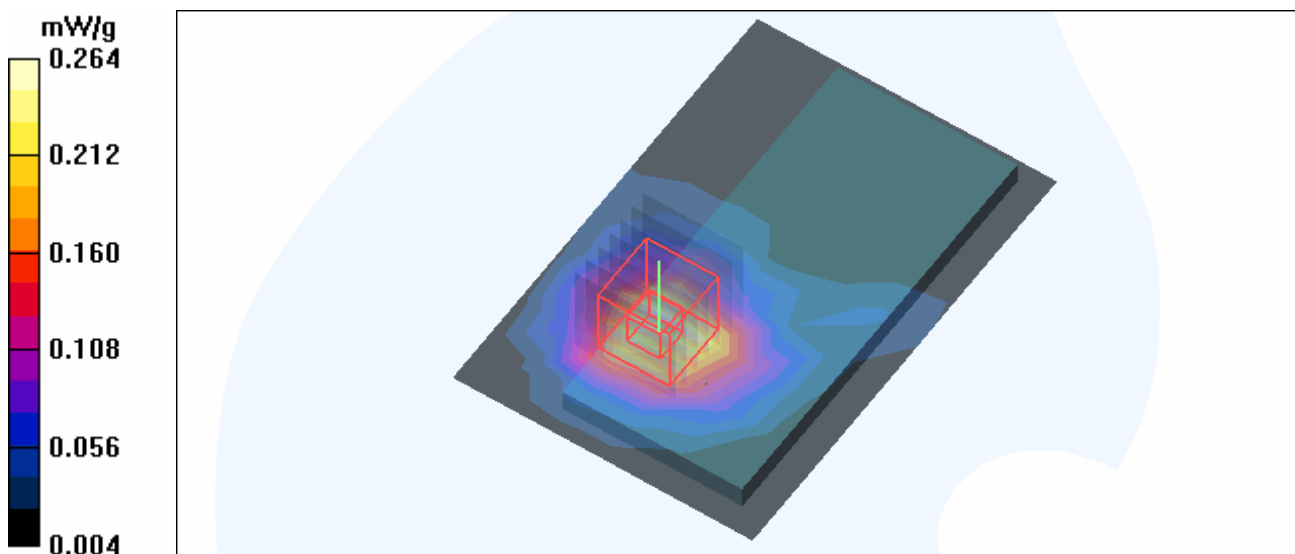

Test Laboratory: Advance Data Technology

## D600-11g-Ch1-Mode 10

**DUT: N1 Wireless Notebook Card ; Type: F5D8011 v3000 ; Test Frequency: 2412 MHz**

Communication System: 802.11g ; Frequency: 2412 MHz ; Duty Cycle: 1:1 ; Modulation type: BPSK  
 Medium: MSL2450 Medium parameters used:  $f = 2412 \text{ MHz}$ ;  $\sigma = 1.93 \text{ mho/m}$ ;  $\epsilon_r = 52.3$ ;  $\rho = 1000 \text{ kg/m}^3$  ; Liquid level : 151 mm

Phantom section: Flat Section ; Separation distance : 16 mm (The bottom side of the EUT to the Phantom)  
 Antenna type : Printed Antenna ; Air temp. : 21.4 degrees ; Liquid temp. : 20.3 degrees

DASY4 Configuration:

- Probe: ET3DV6 - SN1790 ; ConvF(4.35, 4.35, 4.35) ; Calibrated: 2006/11/23
- Sensor-Surface: 4mm (Mechanical Surface Detection)
- Electronics: DAE3 Sn579 ; Calibrated: 2006/3/15
- Phantom: SAM 12 ; Type: SAM V4.0 ; Serial: TP 1202
- Measurement SW: DASY4, V4.7 Build 53 ; Postprocessing SW: SEMCAD, V1.8 Build 172

**Low Channel 1/Area Scan (7x10x1):** Measurement grid:  $dx=15\text{mm}$ ,  $dy=15\text{mm}$   
 Maximum value of SAR (measured) = 0.205 mW/g

**Low Channel 1/Zoom Scan (7x7x7) (7x7x7)/Cube 0:** Measurement grid:  $dx=5\text{mm}$ ,  $dy=5\text{mm}$ ,  $dz=5\text{mm}$

Reference Value = 8.1 V/m

Peak SAR (extrapolated) = 0.472 W/kg

**SAR(1 g) = 0.224 mW/g; SAR(10 g) = 0.122 mW/g**

Maximum value of SAR (measured) = 0.236 mW/g

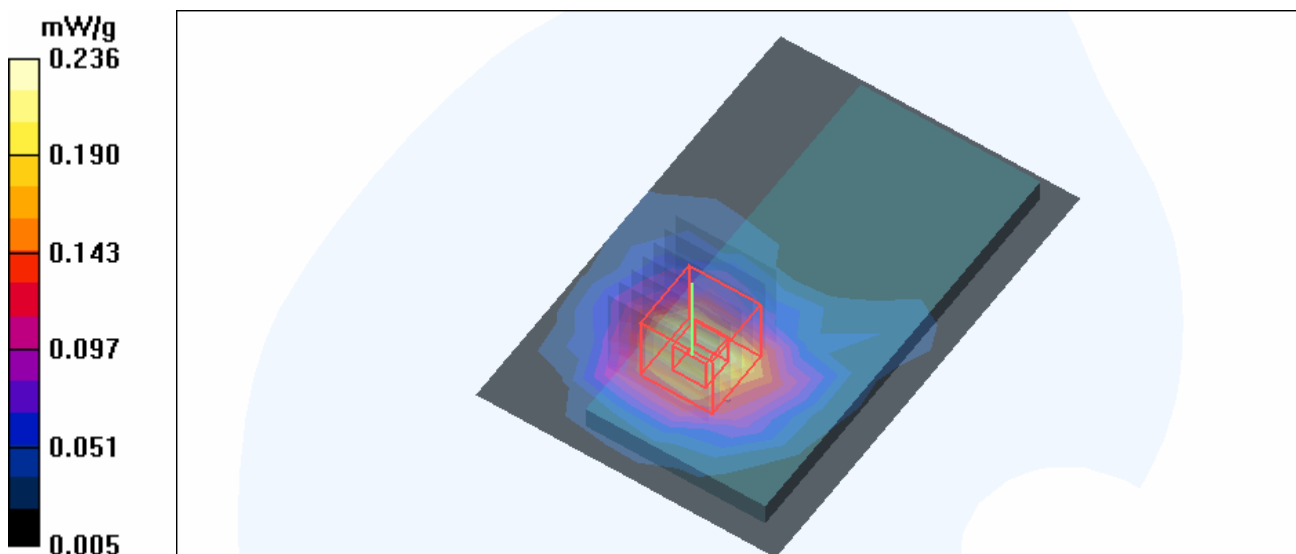

Test Laboratory: Advance Data Technology

## D600-11n-20M-Ch11-Mode 11

**DUT: N1 Wireless Notebook Card ; Type: F5D8011 v3000 ; Test Frequency: 2462 MHz**

Communication System: 802.11n ; Frequency: 2462 MHz ; Duty Cycle: 1:1 ; Modulation type: BPSK  
 Medium: MSL2450 Medium parameters used:  $f = 2462$  MHz;  $\sigma = 2$  mho/m;  $\epsilon_r = 52.1$ ;  $\rho = 1000$  kg/m<sup>3</sup> ; Liquid level : 151 mm

Phantom section: Flat Section ; Separation distance : 16 mm (The bottom side of the EUT to the Phantom)  
 Antenna type : Printed Antenna ; Air temp. : 21.4 degrees ; Liquid temp. : 20.3 degrees

DASY4 Configuration:

- Probe: ET3DV6 - SN1790 ; ConvF(4.35, 4.35, 4.35) ; Calibrated: 2006/11/23
- Sensor-Surface: 4mm (Mechanical Surface Detection)
- Electronics: DAE3 Sn579 ; Calibrated: 2006/3/15
- Phantom: SAM 12 ; Type: SAM V4.0 ; Serial: TP 1202
- Measurement SW: DASY4, V4.7 Build 53 ; Postprocessing SW: SEMCAD, V1.8 Build 172

**High Channel 11/Area Scan (7x10x1):** Measurement grid: dx=15mm, dy=15mm  
 Maximum value of SAR (measured) = 0.278 mW/g

**High Channel 11/Zoom Scan (7x7x7) (7x7x7)/Cube 0:** Measurement grid: dx=5mm, dy=5mm, dz=5mm

Reference Value = 8.6 V/m

Peak SAR (extrapolated) = 0.608 W/kg

**SAR(1 g) = 0.274 mW/g; SAR(10 g) = 0.147 mW/g**

Maximum value of SAR (measured) = 0.289 mW/g

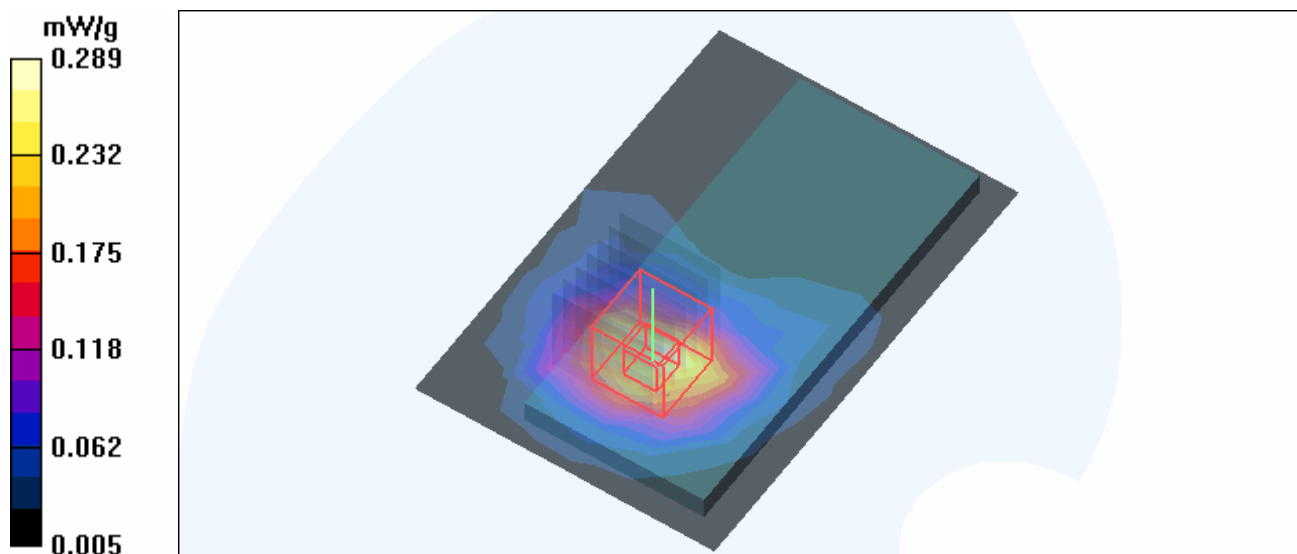

Test Laboratory: Advance Data Technology

## D600-11n-40M-Ch1-Mode 12

**DUT: N1 Wireless Notebook Card ; Type: F5D8011 v3000 ; Test Frequency: 2422 MHz**

Communication System: 802.11n ; Frequency: 2422 MHz ; Duty Cycle: 1:1 ; Modulation type: BPSK  
 Medium: MSL2450 Medium parameters used :  $f = 2422 \text{ MHz}$ ;  $\sigma = 1.94 \text{ mho/m}$ ;  $\epsilon_r = 52.3$ ;  $\rho = 1000 \text{ kg/m}^3$  ; Liquid level : 151 mm

Phantom section: Flat Section ; Separation distance : 16 mm (The bottom side of the EUT to the Phantom)  
 Antenna type : Printed Antenna ; Air temp. : 21.4 degrees ; Liquid temp. : 20.3 degrees

DASY4 Configuration:

- Probe: ET3DV6 - SN1790 ; ConvF(4.35, 4.35, 4.35) ; Calibrated: 2006/11/23
- Sensor-Surface: 4mm (Mechanical Surface Detection)
- Electronics: DAE3 Sn579 ; Calibrated: 2006/3/15
- Phantom: SAM 12 ; Type: SAM V4.0 ; Serial: TP 1202
- Measurement SW: DASY4, V4.7 Build 53 ; Postprocessing SW: SEMCAD, V1.8 Build 172

**Low Channel 1/Area Scan (7x10x1):** Measurement grid:  $dx=15\text{mm}$ ,  $dy=15\text{mm}$   
 Maximum value of SAR (measured) = 0.051 mW/g

**Low Channel 1/Zoom Scan (7x7x7) (7x7x7)/Cube 0:** Measurement grid:  $dx=5\text{mm}$ ,  $dy=5\text{mm}$ ,  $dz=5\text{mm}$

Reference Value = 4.44 V/m

Peak SAR (extrapolated) = 0.116 W/kg

**SAR(1 g) = 0.051 mW/g; SAR(10 g) = 0.028 mW/g**

Maximum value of SAR (measured) = 0.054 mW/g

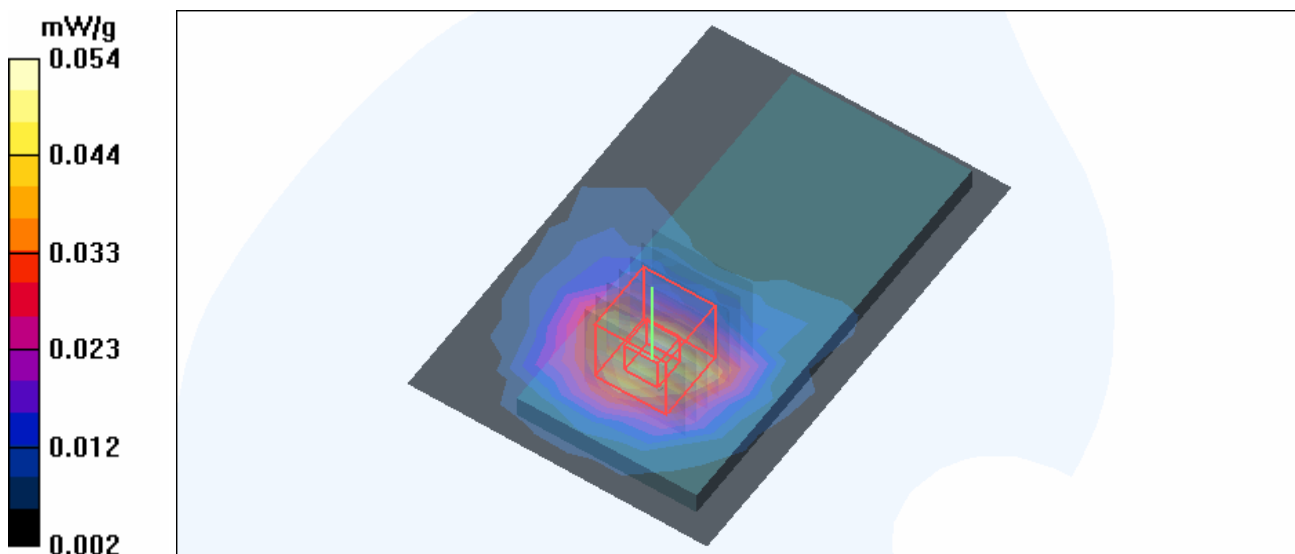

Test Laboratory: Advance Data Technology

## System Validation Check-MSL 2450MHz

**DUT: Dipole 2450 MHz ; Type: D2450V2 ; Serial: 737 ; Test Frequency: 2450 MHz**

Communication System: CW ; Frequency: 2450 MHz; Duty Cycle: 1:1; Modulation type: CW  
 Medium: MSL2450; Medium parameters used:  $f = 2450$  MHz;  $\sigma = 1.98$  mho/m;  $\epsilon_r = 52.1$ ;  $\rho = 1000$  kg/m<sup>3</sup> ; Liquid level : 151 mm  
 Phantom section: Flat Section ; Separation distance : 10 mm (The feetpoint of the dipole to the Phantom) Air temp. : 21.4 degrees ; Liquid temp. : 20.3 degrees

DASY4 Configuration:

- Probe: ET3DV6 - SN1790 ; ConvF(4.35, 4.35, 4.35) ; Calibrated: 2006/11/23
- Sensor-Surface: 4mm (Mechanical Surface Detection)
- Electronics: DAE3 Sn579; Calibrated: 2006/3/15
- Phantom: SAM 12; Type: SAM V4.0; Serial: TP 1202
- Measurement SW: DASY4, V4.7 Build 53; Postprocessing SW: SEMCAD, V1.8 Build 172

**d=10mm, Pin=250mW/Area Scan (5x7x1):** Measurement grid: dx=15mm, dy=15mm  
 Maximum value of SAR (measured) = 16.0 mW/g

**d=10mm, Pin=250mW/Zoom Scan (7x7x7)/Cube 0:** Measurement grid: dx=5mm, dy=5mm, dz=5mm

Reference Value = 93.6 V/m; Power Drift = -0.192 dB

Peak SAR (extrapolated) = 33.6 W/kg

**SAR(1 g) = 14.1 mW/g; SAR(10 g) = 6.35 mW/g**

Maximum value of SAR (measured) = 15.7 mW/g

