



# FCC TEST REPORT

**REPORT NO.:** RF931005L09  
**MODEL NO.:** F5D7633-4  
**RECEIVED:** Oct. 05, 2004  
**TESTED:** Oct. 05 ~ Dec. 09, 2004  
**ISSUED:** Dec. 15, 2004

**APPLICANT:** Belkin Corporation

**ADDRESS:** 501 West Walnut Avenue, Compton, CA 90220,  
U.S.A

**ISSUED BY:** Advance Data Technology Corporation

**LAB ADDRESS:** No. 47, 14th Ling, Chia Pau Tsuen, Lin Kou  
Hsiang 244, Taipei Hsien, Taiwan, R.O.C.

**TEST LOCATION:** No. 19, Hwa Ya 2<sup>nd</sup> Rd., Wen Hwa Tsuen, Kwei  
Shan Hsiang, Taoyuan Hsien 333, Taiwan,  
R.O.C.

This test report consists of 78 pages in total. It may be duplicated completely for legal use with the approval of the applicant. It should not be reproduced except in full, without the written approval of our laboratory. The client should not use it to claim product endorsement by CNLA, A2LA or any government agencies. The test results in the report only apply to the tested sample.





## Table of Contents

1	CERTIFICATION .....	4
2	SUMMARY OF TEST RESULTS .....	5
2.1	GENERAL DESCRIPTION OF EUT .....	6
3	GENERAL INFORMATION .....	7
3.1	GENERAL DESCRIPTION OF EUT .....	7
3.2	DESCRIPTION OF TEST MODES.....	8
3.3	GENERAL DESCRIPTION OF APPLIED STANDARDS.....	8
3.4	DESCRIPTION OF SUPPORT UNITS .....	9
3.5	CONFIGURATION OF SYSTEM UNDER TEST .....	10
4	TEST TYPES AND RESULTS .....	11
4.1	CONDUCTED EMISSION MEASUREMENT .....	11
4.1.1	LIMITS OF CONDUCTED EMISSION MEASUREMENT .....	11
4.1.2	TEST INSTRUMENTS .....	11
4.1.3	TEST PROCEDURES .....	12
4.1.4	DEVIATION FROM TEST STANDARD .....	12
4.1.5	TEST SETUP .....	13
4.1.6	EUT OPERATING CONDITIONS .....	14
4.1.7	TEST RESULTS.....	15
4.2	RADIATED EMISSION MEASUREMENT .....	27
4.2.1	LIMITS OF RADIATED EMISSION MEASUREMENT .....	27
4.2.2	TEST INSTRUMENTS .....	28
4.2.3	TEST PROCEDURES .....	28
4.2.4	DEVIATION FROM TEST STANDARD .....	29
4.2.5	TEST SETUP .....	30
4.2.6	EUT OPERATING CONDITIONS .....	30
4.2.7	TEST RESULTS.....	31
4.2.8	TEST RESULTS (A) .....	35
4.2.9	TEST RESULTS (B).....	38
4.3	6dB BANDWIDTH MEASUREMENT .....	41
4.3.1	LIMITS OF 6dB BANDWIDTH MEASUREMENT .....	41
4.3.2	TEST INSTRUMENTS .....	41
4.3.3	TEST PROCEDURE .....	42
4.3.4	DEVIATION FROM TEST STANDARD .....	42
4.3.5	TEST SETUP .....	42
4.3.6	EUT OPERATING CONDITIONS .....	42
4.3.7	TEST RESULTS (A) .....	43
4.3.8	TEST RESULTS (B).....	47
4.4	MAXIMUM PEAK OUTPUT POWER .....	51
4.4.1	LIMITS OF MAXIMUM PEAK OUTPUT POWER MEASUREMENT .....	51



4.4.2	TEST INSTRUMENTS .....	51
4.4.3	TEST PROCEDURES .....	52
4.4.4	DEVIATION FROM TEST STANDARD .....	52
4.4.5	TEST SETUP .....	52
4.4.6	EUT OPERATING CONDITIONS .....	52
4.4.7	TEST RESULTS (A) .....	53
4.4.8	TEST RESULTS (B).....	54
4.5	POWER SPECTRAL DENSITY MEASUREMENT.....	55
4.5.1	LIMITS OF POWER SPECTRAL DENSITY MEASUREMENT.....	55
4.5.2	TEST INSTRUMENTS .....	55
4.5.3	TEST PROCEDURE.....	56
4.5.4	DEVIATION FROM TEST STANDARD .....	56
4.5.5	TEST SETUP .....	56
4.5.6	EUT OPERATING CONDITIONS .....	56
4.5.7	TEST RESULTS (A) .....	57
4.5.8	TEST RESULTS (B).....	61
4.6	BAND EDGES MEASUREMENT.....	65
4.6.1	LIMITS OF BAND EDGES MEASUREMENT.....	65
4.6.2	TEST INSTRUMENTS .....	65
4.6.3	TEST PROCEDURE.....	65
4.6.4	DEVIATION FROM TEST STANDARD .....	65
4.6.5	EUT OPERATING CONDITION.....	65
4.6.6	TEST RESULTS.....	66
4.6.7	TEST RESULTS (A) .....	66
4.6.8	TEST RESULTS (B).....	66
4.7	ANTENNA REQUIREMENT.....	75
4.7.1	STANDARD APPLICABLE.....	75
4.7.2	ANTENNA CONNECTED CONSTRUCTION.....	75
5	PHOTOGRAPHS OF THE TEST CONFIGURATION .....	76
6	INFORMATION ON THE TESTING LABORATORIES.....	78



## 1 CERTIFICATION

**PRODUCT :** ADSL Modem with High-Speed Mode Wireless-G Router

**MODEL NO. :** F5D7633-4

**BRAND NAME :** Belkin

**APPLICANT :** Belkin Corporation

**TESTED :** Oct. 05 ~ Dec. 09, 2004

**TEST SAMPLE :** ENGINEERING SAMPLE

**STANDARDS :** FCC Part 15, Subpart C (Section 15.247),  
ANSI C63.4-2003

The above equipment has been tested by **Advance Data Technology Corporation**, and found compliance with the requirement of the above standards. The test record, data evaluation & Equipment Under Test (EUT) configurations represented herein are true and accurate accounts of the measurements of the sample's EMC characteristics under the conditions specified in this report.

**PREPARED BY :** Candice Chen , **DATE:** Dec. 15, 2004  
( Candice Chen )

**TECHNICAL**  
**ACCEPTANCE :** Gary Chang , **DATE:** Dec. 15, 2004  
Responsible for RF ( Gary Chang )

**APPROVED BY :** Cody Chang , **DATE:** Dec. 15, 2004  
( Cody Chang,  
Deputy Manager )



## 2 SUMMARY OF TEST RESULTS

The EUT has been tested according to the following specifications:

<b>APPLIED STANDARD: FCC Part 15, Subpart C</b>			
<b>Standard Section</b>	<b>Test Type and Limit</b>	<b>Result</b>	<b>REMARK</b>
15.207	AC Power Conducted Emission	PASS	Meet the requirement of limit. Minimum passing margin is -9.49dB at 1.250MHz
15.247(a)(2)	Spectrum Bandwidth of a Direct Sequence Spread Spectrum System Limit: min. 500kHz	PASS	Meet the requirement of limit.
15.247(b)	Maximum Peak Output Power Limit: max. 30dBm	PASS	Meet the requirement of limit.
15.247(d)	Transmitter Radiated Emissions Limit: Table 15.209	PASS	Meet the requirement of limit. Minimum passing margin is -1.17dB at 2390.00MHz
15.247(e)	Power Spectral Density Limit: max. 8dBm	PASS	Meet the requirement of limit.
15.247(d)	Band Edge Measurement Limit: 20 dB less than the peak value of fundamental frequency	PASS	Meet the requirement of limit.

## 2.1 GENERAL DESCRIPTION OF EUT

Where relevant, the following measurement uncertainty levels have been estimated for tests performed on the EUT as specified in CISPR 16-4:

MEASUREMENT	FREQUENCY	UNCERTAINTY
Conducted emissions	9kHz~30MHz	2.44 dB
Radiated emissions	30MHz ~ 200MHz	3.73 dB
	200MHz ~1000MHz	3.74 dB
	1GHz ~ 18GHz	2.20 dB
	18GHz ~ 40GHz	1.88 dB



### 3 GENERAL INFORMATION

#### 3.1 GENERAL DESCRIPTION OF EUT

<b>PRODUCT</b>	ADSL Modem with High-Speed Mode Wireless-G Router
<b>MODEL NO.</b>	F5D7633-4
<b>POWER SUPPLY</b>	15.0Vdc from AC adapter
<b>MODULATION TYPE</b>	CCK, DQPSK, DBPSK for DSSS 64QAM, 16QAM, QPSK, BPSK for OFDM
<b>RADIO TECHNOLOGY</b>	DSSS, OFDM
<b>TRANSFER RATE</b>	802.11b: 11/5.5/2/1Mbps 802.11g: 54/48/36/24/18/12/9/6Mbps
<b>FREQUENCY RANGE</b>	2412MHz ~ 2462MHz
<b>NUMBER OF CHANNEL</b>	11
<b>OUTPUT POWER</b>	33.11mW
<b>ANTENNA TYPE</b>	Dipole antenna with 2dBi gain
<b>DATA CABLE</b>	NA
<b>I/O PORTS</b>	RJ45, RJ11
<b>ASSOCIATED DEVICES</b>	NA

**NOTE:**

1. The EUT was tested with the following adapters:

<b>BRAND:</b>	LEADER ELECTRONICS INC.
<b>MODEL :</b>	MU15-150100-A1
<b>INPUT :</b>	100-240Vac, 50-60Hz, 0.5A
<b>OUTPUT :</b>	15.0Vdc, 1.0A
<b>POWER LINE</b>	1.8m noshielded cable without core ( AC 2pin )

<b>BRAND:</b>	DVE
<b>MODEL :</b>	DVS-120A15AUS
<b>INPUT :</b>	100-120Vac, 50-60Hz, 0.7A
<b>OUTPUT :</b>	15.0Vdc, 1.0A, 1.8 m, without core
<b>POWER LINE</b>	1.8m noshielded cable without core ( AC 2pin )

- The EUT operates in the 2.4GHz frequency spectrum with throughput of up to 54Mbps.
- The EUT complies with IEEE 802.11g standards and backwards compatible with IEEE 802.11b products.
- The above EUT information was declared by manufacturer and for more detailed features description, please refer to the manufacturer's specifications or User's Manual.



### 3.2 DESCRIPTION OF TEST MODES

Eleven channels are provided to this EUT.

Channel	Frequency	Channel	Frequency
1	2412 MHz	7	2442 MHz
2	2417 MHz	8	2447 MHz
3	2422 MHz	9	2452 MHz
4	2427 MHz	10	2457 MHz
5	2432 MHz	11	2462 MHz
6	2437 MHz		

**NOTE:**

1. Below 1GHz, the channel 1, 6, and 11 were pre-tested in chamber. The channel 11 with OFDM technique, the worst case, was chosen for final test.
2. Above 1GHz, the channel 1, 6, and 11 were tested individually.
3. From our experience and technical viewpoint, we have chosen data rates 11Mbps for CCK technique and 6Mbps for OFDM technique, as the worst cases for the test among other data rates.
4. Two test results were presented in the following sections. The test result A was for CCK technique and the test result B was for OFDM technique.
5. For Conducted emission and Radiated emission below 1GHz test, two test modes were presented in following sections, the test mode 1 is for adapter model MU15-150100-A1, the test mode 2 is for adapter model DVS-120A15AUS.

### 3.3 GENERAL DESCRIPTION OF APPLIED STANDARDS

The EUT is a ADSL Modem with High-Speed Mode Wireless-G Router. According to the specifications of the manufacturer, it must complies with the requirements of the following standards:

**FCC Part 15, Subpart C. (15.247)**

**ANSI C63.4: 2003**

All test items have been performed and recorded as per the above standards.

**NOTE:** The EUT is also considered as a kind of computer peripheral, because the connection to computer is necessary for typical use. It has been verified to comply with the requirements of FCC Part 15, Subpart B, Class B (DoC). The test report has been issued separately.





### 3.4 DESCRIPTION OF SUPPORT UNITS

The EUT has been tested as an independent unit together with other necessary accessories or support units. The following support units or accessories were used to form a representative test configuration during the tests.

NO.	PRODUCT	BRAND	MODEL NO.	SERIAL NO.	FCC ID
1	NOTEBOOK COMPUTER	DELL	PP05L	12130898320	E2K24CLNS
2	PRINTER	EPSON	LQ-300+	DCGY054147	FCC DoC Approved
3	MODEM	ACEEX	1414V/3	0401008269	IFAXDM1414
4	NOTEBOOK COMPUTER	DELL	PP05L	16484462992	E2K24CLNS
5	ADSL Co- Router	AC5 Evaluation Module	Texas	NA	NA

NO.	SIGNAL CABLE DESCRIPTION OF THE ABOVE SUPPORT UNITS
1	NA
2	1.2m shielded cable without core.
3	1.2m shielded cable without core.
4	NA
5	NA

**NOTE:**

1. All power cords of the above support units are non shielded (1.8m).
2. Item 4-5 act as a communication partner to transfer data.



### 3.5 CONFIGURATION OF SYSTEM UNDER TEST

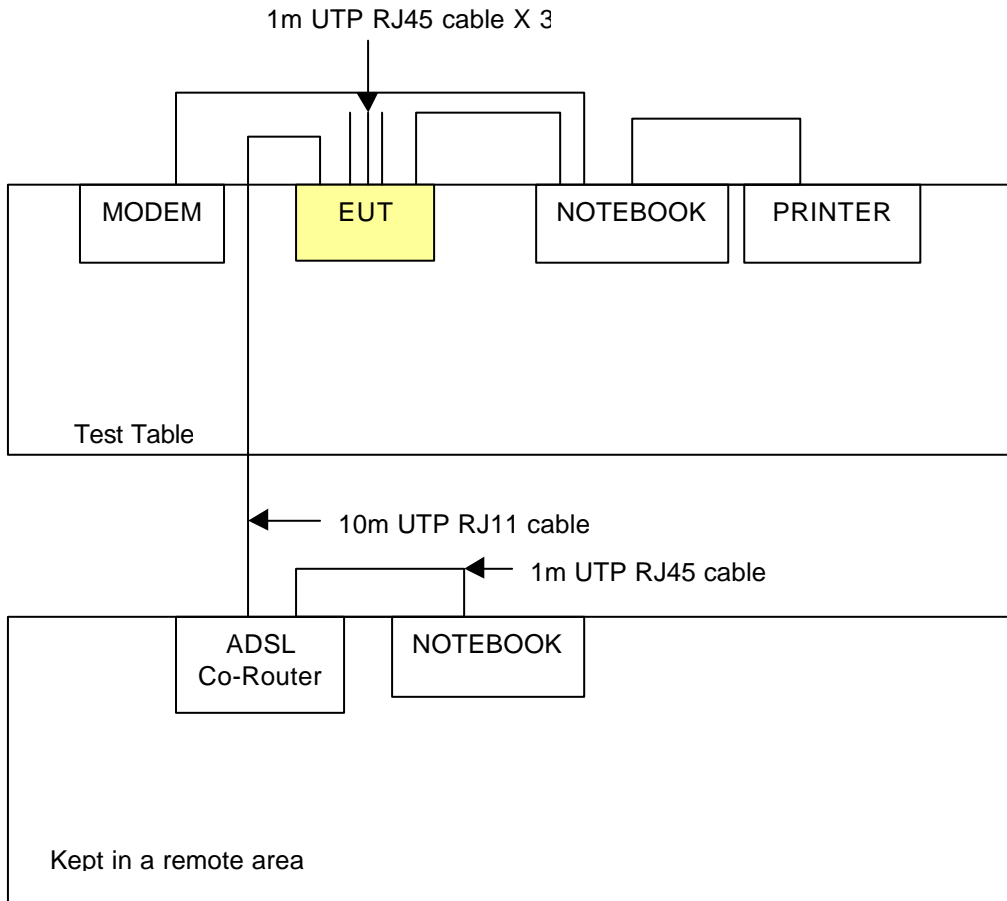



## 4 TEST TYPES AND RESULTS

### 4.1 CONDUCTED EMISSION MEASUREMENT

#### 4.1.1 LIMITS OF CONDUCTED EMISSION MEASUREMENT

FREQUENCY OF EMISSION (MHz)	CONDUCTED LIMIT (dB $\mu$ V)	
	Quasi-peak	Average
0.15-0.5	66 to 56	56 to 46
0.5-5	56	46
5-30	60	50

- NOTE:**
1. The lower limit shall apply at the transition frequencies.
  2. The limit decreases in line with the logarithm of the frequency in the range of 0.15 to 0.50 MHz.
  3. All emanations from a class A/B digital device or system, including any network of conductors and apparatus connected thereto, shall not exceed the level of field strengths specified above.

#### 4.1.2 TEST INSTRUMENTS

DESCRIPTION & MANUFACTURER	MODEL NO.	SERIAL NO.	CALIBRATED UNTIL
Test Receiver ROHDE & SCHWARZ	ESCS30	100291	Nov. 16, 2005
RF signal cable Woken	5D-FB	Cable-HYC01-01	Mar. 02, 2005
LISN ROHDE & SCHWARZ	ESH3-Z5	100312	Mar. 03, 2005
LISN ROHDE & SCHWARZ	ESH2-Z5	100104	Mar. 02, 2005
Software ADT	ADT_Cond_V3	NA	NA

- NOTE:**
1. The calibration interval of the above test instruments is 12 months and the calibrations are traceable to NML/ROC and NIST/USA.
  2. The test was performed in HwaYa Shielded Room 1.
  3. The VCCI Site Registration No. is C-2040.



#### 4.1.3 TEST PROCEDURES

- a. The EUT was placed 0.4 meters from the conducting wall of the shielded room with EUT being connected to the power mains through a line impedance stabilization network (LISN). Other support units were connected to the power mains through another LISN. The two LISNs provide 50 ohm/ 50uH of coupling impedance for the measuring instrument.
- b. Both lines of the power mains connected to the EUT were checked for maximum conducted interference.
- c. The frequency range from 150 kHz to 30 MHz was searched. Emission levels (Limit -20dB) was not recorded.

#### 4.1.4 DEVIATION FROM TEST STANDARD

No deviation

## 4.1.5 TEST SETUP

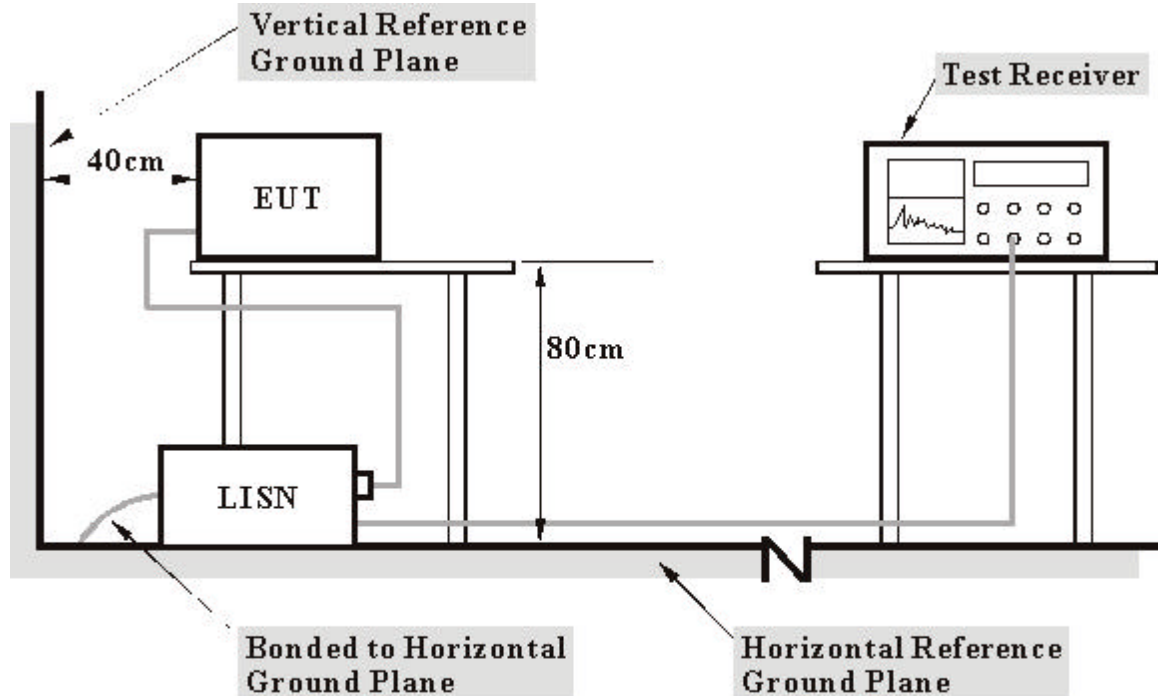

- Note:**
1. Support units were connected to second LISN.
  2. Both of LISNs (AMN) 80 cm from EUT and at the least 80 cm from other units and other metal planes support units.

For the actual test configuration, please refer to the related item – Photographs of the Test Configuration.



#### 4.1.6 EUT OPERATING CONDITIONS

- a. Placed the EUT on the testing table.
- b. Prepared another Notebook system and ADSL modem to act as a communication partner and placed it outside of testing area.
- c. The communication partner run a test program (provided by manufacturer) to enable EUT under transmission/receiving condition continuously at specific channel frequency via an RJ45 cable.
- d. The communication partner sent data to EUT by command "PING".



4.1.7 TEST RESULTS

<b>EUT</b>	ADSL Modem with High-Speed Mode Wireless-G Router	<b>MODEL</b>	F5D7633-4
<b>CHANNEL</b>	1	<b>6dB BANDWIDTH</b>	9 kHz
<b>INPUT POWER (SYSTEM)</b>	120 Vac, 60 Hz	<b>PHASE</b>	Line (L)
<b>ENVIRONMENTAL CONDITIONS</b>	24 deg. C, 64% RH, 991 hPa	<b>TEST MODE</b>	1
<b>TESTED BY</b>	Leo Hung		

No	Freq. [MHz]	Corr. Factor (dB)	Reading Value [dB (uV)]		Emission Level [dB (uV)]		Limit [dB (uV)]		Margin (dB)	
			Q.P.	AV.	Q.P.	AV.	Q.P.	AV.	Q.P.	AV.
1	0.209	0.12	33.94	-	34.06	-	63.26	53.26	-29.20	-
2	0.677	0.13	38.62	-	38.75	-	56.00	46.00	-17.25	-
3	0.888	0.14	41.21	-	41.35	-	56.00	46.00	-14.65	-
4	1.324	0.15	42.11	-	42.26	-	56.00	46.00	-13.74	-
5	2.309	0.17	40.20	-	40.37	-	56.00	46.00	-15.63	-
6	3.855	0.20	44.54	-	44.74	-	56.00	46.00	-11.26	-

- REMARKS:**
1. Q.P. and AV. are abbreviations of quasi-peak and average individually.
  2. "-": The Quasi-peak reading value also meets average limit and measurement with the average detector is unnecessary.
  3. The emission levels of other frequencies were very low against the limit.
  4. Margin value = Emission level - Limit value
  5. Correction factor = Insertion loss + Cable loss
  6. Emission Level = Correction Factor + Reading Value.

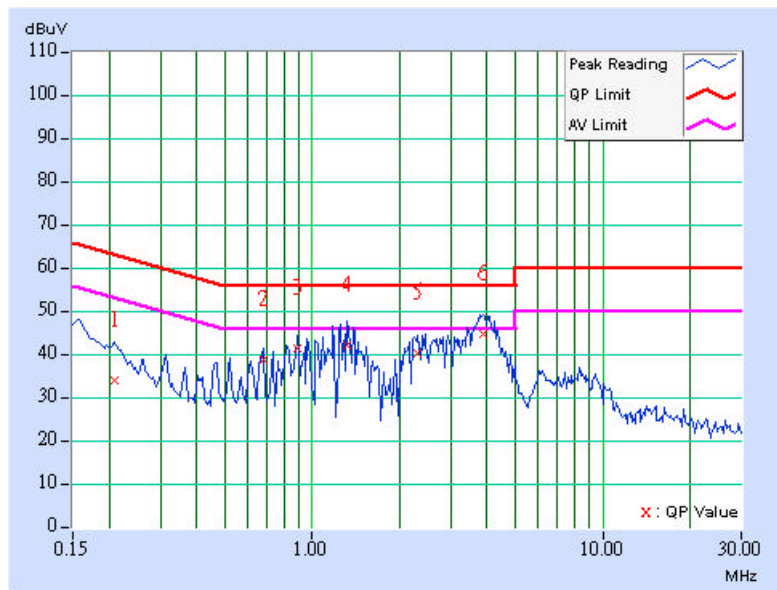



<b>EUT</b>	ADSL Modem with High-Speed Mode Wireless-G Router	<b>MODEL</b>	F5D7633-4
<b>CHANNEL</b>	1	<b>6dB BANDWIDTH</b>	9 kHz
<b>INPUT POWER (SYSTEM)</b>	120 Vac, 60 Hz	<b>PHASE</b>	Neutral (N)
<b>ENVIRONMENTAL CONDITIONS</b>	24 deg. C, 64% RH, 991 hPa	<b>TEST MODE</b>	1
<b>TESTED BY</b>	Leo Hung		

No	Freq. [MHz]	Corr. Factor (dB)	Reading Value [dB (uV)]		Emission Level [dB (uV)]		Limit [dB (uV)]		Margin (dB)	
			Q.P.	AV.	Q.P.	AV.	Q.P.	AV.	Q.P.	AV.
			1	0.213	0.11	33.10	-	33.21	-	63.11
2	0.888	0.14	40.51	-	40.65	-	56.00	46.00	-15.35	-
<b>3</b>	<b>1.250</b>	<b>0.15</b>	<b>46.36</b>	<b>32.66</b>	<b>46.51</b>	<b>32.81</b>	<b>56.00</b>	<b>46.00</b>	<b>-9.49</b>	<b>-13.19</b>
4	1.461	0.15	43.90	-	44.05	-	56.00	46.00	-11.95	-
5	2.809	0.18	40.98	-	41.16	-	56.00	46.00	-14.84	-
6	4.023	0.20	45.22	-	45.42	-	56.00	46.00	-10.58	-

- REMARKS:**
1. Q.P. and AV. are abbreviations of quasi-peak and average individually.
  2. "-": The Quasi-peak reading value also meets average limit and measurement with the average detector is unnecessary.
  3. The emission levels of other frequencies were very low against the limit.
  4. Margin value = Emission level - Limit value
  5. Correction factor = Insertion loss + Cable loss
  6. Emission Level = Correction Factor + Reading Value.

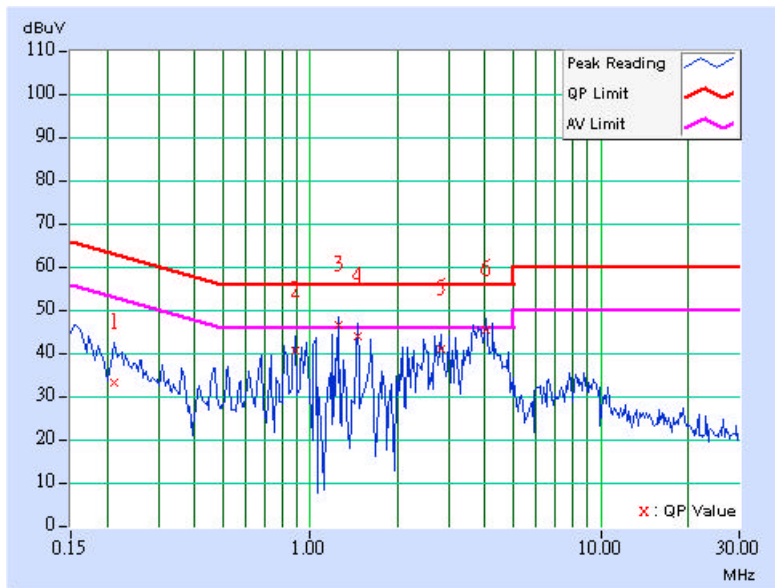





<b>EUT</b>	ADSL Modem with High-Speed Mode Wireless-G Router	<b>MODEL</b>	F5D7633-4
<b>CHANNEL</b>	6	<b>6dB BANDWIDTH</b>	9 kHz
<b>INPUT POWER (SYSTEM)</b>	120 Vac, 60 Hz	<b>PHASE</b>	Line (L)
<b>ENVIRONMENTAL CONDITIONS</b>	24 deg. C, 64% RH, 991 hPa	<b>TEST MODE</b>	1
<b>TESTED BY</b>	Leo Hung		

No	Freq. [MHz]	Corr. Factor (dB)	Reading Value [dB (uV)]		Emission Level [dB (uV)]		Limit [dB (uV)]		Margin (dB)	
			Q.P.	AV.	Q.P.	AV.	Q.P.	AV.	Q.P.	AV.
			1	0.205	0.12	34.31	-	34.43	-	63.42
2	0.474	0.13	31.74	-	31.87	-	56.44	46.44	-24.57	-
3	0.888	0.14	40.99	-	41.13	-	56.00	46.00	-14.87	-
4	1.445	0.15	39.05	-	39.20	-	56.00	46.00	-16.80	-
5	2.441	0.17	38.86	-	39.03	-	56.00	46.00	-16.97	-
6	3.953	0.21	44.35	-	44.56	-	56.00	46.00	-11.44	-

- REMARKS:**
1. Q.P. and AV. are abbreviations of quasi-peak and average individually.
  2. "-": The Quasi-peak reading value also meets average limit and measurement with the average detector is unnecessary.
  3. The emission levels of other frequencies were very low against the limit.
  4. Margin value = Emission level - Limit value
  5. Correction factor = Insertion loss + Cable loss
  6. Emission Level = Correction Factor + Reading Value.

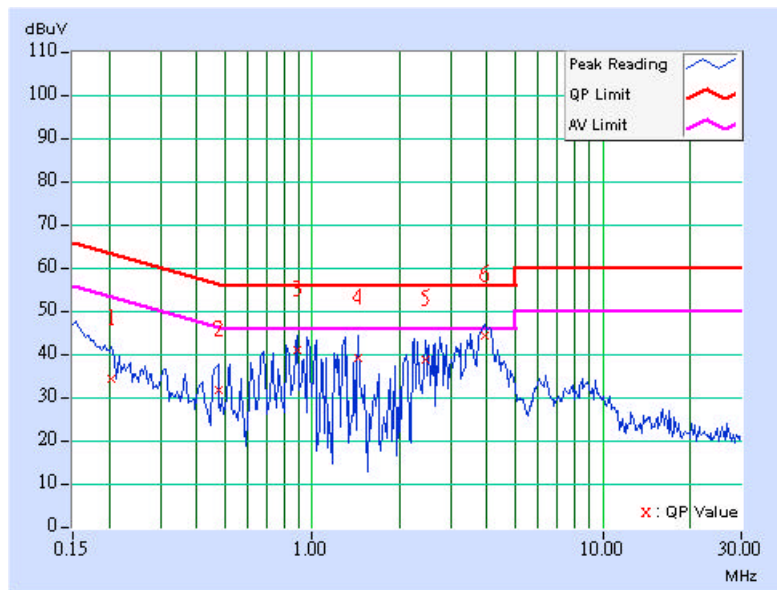



<b>EUT</b>	ADSL Modem with High-Speed Mode Wireless-G Router	<b>MODEL</b>	F5D7633-4
<b>CHANNEL</b>	6	<b>6dB BANDWIDTH</b>	9 kHz
<b>INPUT POWER (SYSTEM)</b>	120 Vac, 60 Hz	<b>PHASE</b>	Neutral (N)
<b>ENVIRONMENTAL CONDITIONS</b>	24 deg. C, 64% RH, 991 hPa	<b>TEST MODE</b>	1
<b>TESTED BY</b>	Leo Hung		

No	Freq. [MHz]	Corr. Factor (dB)	Reading Value [dB (uV)]		Emission Level [dB (uV)]		Limit [dB (uV)]		Margin (dB)	
			Q.P.	AV.	Q.P.	AV.	Q.P.	AV.	Q.P.	AV.
1	0.158	0.10	40.77	-	40.87	-	65.58	55.58	-24.71	-
2	0.220	0.11	32.21	-	32.32	-	62.81	52.81	-30.49	-
3	0.963	0.15	30.61	-	30.76	-	56.00	46.00	-25.24	-
4	1.332	0.15	45.36	-	45.51	-	56.00	46.00	-10.49	-
5	2.957	0.18	41.35	-	41.53	-	56.00	46.00	-14.47	-
6	4.090	0.20	44.27	-	44.47	-	56.00	46.00	-11.53	-

- REMARKS:**
1. Q.P. and AV. are abbreviations of quasi-peak and average individually.
  2. "-": The Quasi-peak reading value also meets average limit and measurement with the average detector is unnecessary.
  3. The emission levels of other frequencies were very low against the limit.
  4. Margin value = Emission level - Limit value
  5. Correction factor = Insertion loss + Cable loss
  6. Emission Level = Correction Factor + Reading Value.

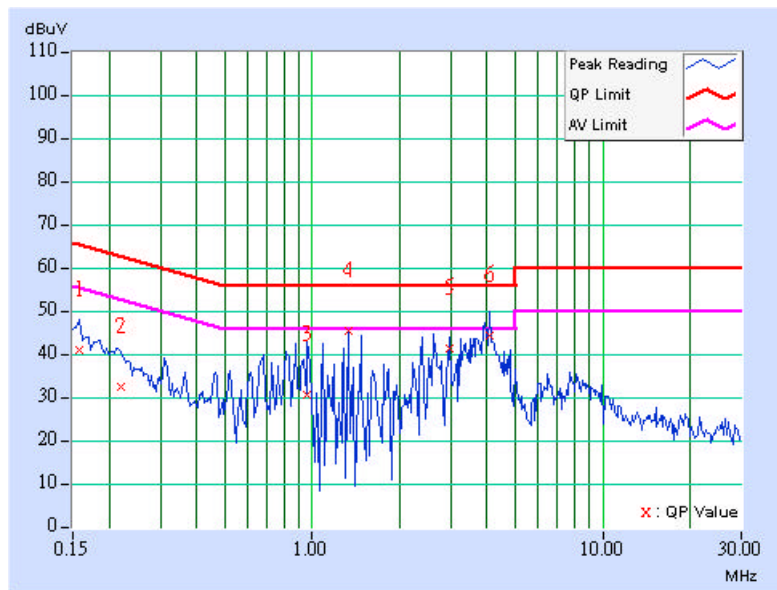



<b>EUT</b>	ADSL Modem with High-Speed Mode Wireless-G Router	<b>MODEL</b>	F5D7633-4
<b>CHANNEL</b>	11	<b>6dB BANDWIDTH</b>	9 kHz
<b>INPUT POWER (SYSTEM)</b>	120 Vac, 60 Hz	<b>PHASE</b>	Line (L)
<b>ENVIRONMENTAL CONDITIONS</b>	24 deg. C, 64% RH, 991 hPa	<b>TEST MODE</b>	1
<b>TESTED BY</b>	Leo Hung		

No	Freq. [MHz]	Corr. Factor [dB]	Reading Value [dB (uV)]		Emission Level [dB (uV)]		Limit [dB (uV)]		Margin (dB)	
			Q.P.	AV.	Q.P.	AV.	Q.P.	AV.	Q.P.	AV.
			1	0.162	0.11	37.97	-	38.08	-	65.38
2	0.814	0.14	38.45	-	38.59	-	56.00	46.00	-17.41	-
3	1.168	0.15	37.93	-	38.08	-	56.00	46.00	-17.92	-
4	1.391	0.15	42.90	-	43.05	-	56.00	46.00	-12.95	-
5	2.457	0.17	41.00	-	41.17	-	56.00	46.00	-14.83	-
6	4.012	0.21	45.42	-	45.63	-	56.00	46.00	-10.37	-

- REMARKS:**
1. Q.P. and AV. are abbreviations of quasi-peak and average individually.
  2. "-": The Quasi-peak reading value also meets average limit and measurement with the average detector is unnecessary.
  3. The emission levels of other frequencies were very low against the limit.
  4. Margin value = Emission level - Limit value
  5. Correction factor = Insertion loss + Cable loss
  6. Emission Level = Correction Factor + Reading Value.

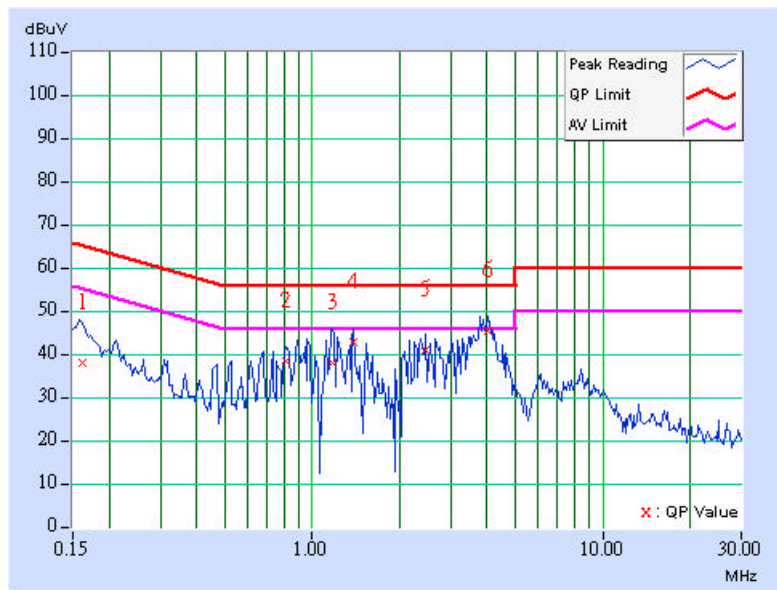



<b>EUT</b>	ADSL Modem with High-Speed Mode Wireless-G Router	<b>MODEL</b>	F5D7633-4
<b>CHANNEL</b>	11	<b>6dB BANDWIDTH</b>	9 kHz
<b>INPUT POWER (SYSTEM)</b>	120 Vac, 60 Hz	<b>PHASE</b>	Netural (N)
<b>ENVIRONMENTAL CONDITIONS</b>	24 deg. C, 64% RH, 991 hPa	<b>TEST MODE</b>	1
<b>TESTED BY</b>	Leo Hung		

No	Freq. [MHz]	Corr. Factor [dB]	Reading Value [dB (uV)]		Emission Level [dB (uV)]		Limit [dB (uV)]		Margin (dB)	
			Q.P.	AV.	Q.P.	AV.	Q.P.	AV.	Q.P.	AV.
			1	0.162	0.10	37.97	-	38.07	-	65.38
2	0.209	0.11	34.10	-	34.21	-	63.26	53.26	-29.05	-
3	0.884	0.14	40.39	-	40.53	-	56.00	46.00	-15.47	-
4	1.391	0.15	45.30	-	45.45	-	56.00	46.00	-10.55	-
5	2.535	0.17	38.90	-	39.07	-	56.00	46.00	-16.93	-
6	3.863	0.20	45.57	-	45.77	-	56.00	46.00	-10.23	-

- REMARKS:**
1. Q.P. and AV. are abbreviations of quasi-peak and average individually.
  2. "-": The Quasi-peak reading value also meets average limit and measurement with the average detector is unnecessary.
  3. The emission levels of other frequencies were very low against the limit.
  4. Margin value = Emission level - Limit value
  5. Correction factor = Insertion loss + Cable loss
  6. Emission Level = Correction Factor + Reading Value.

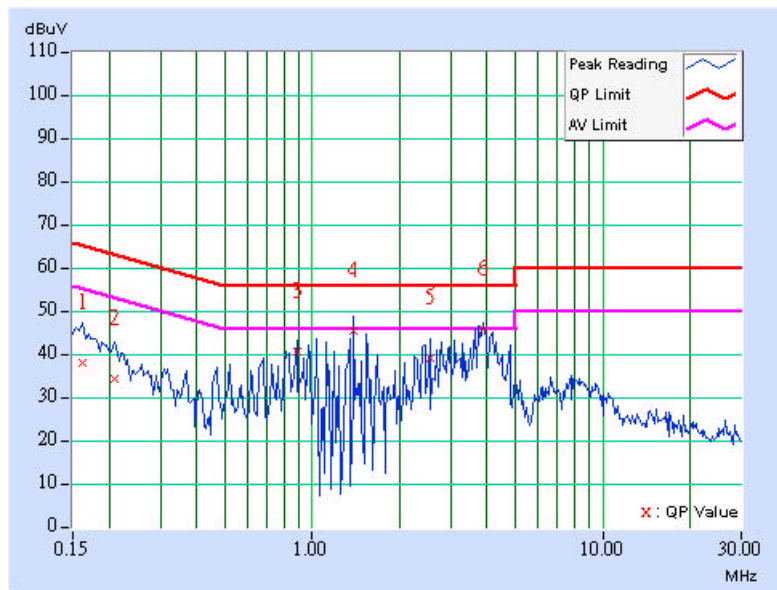



<b>EUT</b>	ADSL Modem with High-Speed Mode Wireless-G Router	<b>MODEL</b>	F5D7633-4
<b>CHANNEL</b>	1	<b>6dB BANDWIDTH</b>	9 kHz
<b>INPUT POWER (SYSTEM)</b>	120 Vac, 60 Hz	<b>PHASE</b>	Line (L)
<b>ENVIRONMENTAL CONDITIONS</b>	23 deg. C, 69% RH, 991 hPa	<b>TEST MODE</b>	2
<b>TESTED BY</b>	Steven Lu		

No	Freq. [MHz]	Corr. Factor [dB]	Reading Value [dB (uV)]		Emission Level [dB (uV)]		Limit [dB (uV)]		Margin (dB)	
			Q.P.	AV.	Q.P.	AV.	Q.P.	AV.	Q.P.	AV.
			1	0.185	0.12	28.63	-	28.75	-	64.25
2	0.400	0.13	36.99	-	37.12	-	57.85	47.85	-20.74	-
3	0.568	0.13	36.79	-	36.92	-	56.00	46.00	-19.08	-
4	0.849	0.14	23.99	-	24.13	-	56.00	46.00	-31.87	-
5	1.539	0.16	34.45	-	34.61	-	56.00	46.00	-21.39	-
6	5.129	0.24	21.48	-	21.72	-	60.00	50.00	-38.28	-

- REMARKS:**
1. Q.P. and AV. are abbreviations of quasi-peak and average individually.
  2. "-": The Quasi-peak reading value also meets average limit and measurement with the average detector is unnecessary.
  3. The emission levels of other frequencies were very low against the limit.
  4. Margin value = Emission level - Limit value
  5. Correction factor = Insertion loss + Cable loss
  6. Emission Level = Correction Factor + Reading Value.

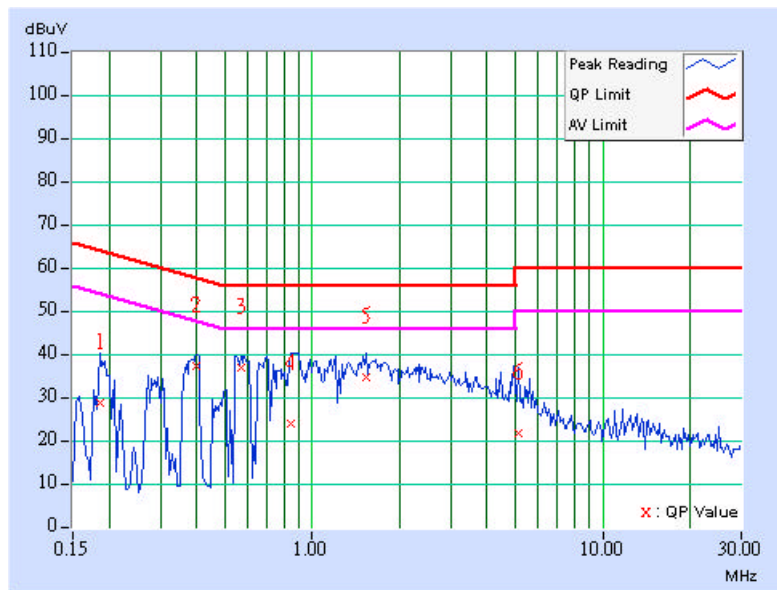



<b>EUT</b>	ADSL Modem with High-Speed Mode Wireless-G Router	<b>MODEL</b>	F5D7633-4
<b>CHANNEL</b>	1	<b>6dB BANDWIDTH</b>	9 kHz
<b>INPUT POWER (SYSTEM)</b>	120 Vac, 60 Hz	<b>PHASE</b>	Netural (N)
<b>ENVIRONMENTAL CONDITIONS</b>	23 deg. C, 69% RH, 991 hPa	<b>TEST MODE</b>	2
<b>TESTED BY</b>	Steven Lu		

No	Freq. [MHz]	Corr. Factor (dB)	Reading Value [dB (uV)]		Emission Level [dB (uV)]		Limit [dB (uV)]		Margin (dB)	
			Q.P.	AV.	Q.P.	AV.	Q.P.	AV.	Q.P.	AV.
			1	0.193	0.11	40.57	-	40.68	-	63.91
2	0.373	0.12	36.79	-	36.91	-	58.44	48.44	-21.54	-
3	0.568	0.12	37.70	-	37.82	-	56.00	46.00	-18.18	-
4	0.865	0.14	35.34	-	35.48	-	56.00	46.00	-20.52	-
5	1.289	0.15	36.04	-	36.19	-	56.00	46.00	-19.81	-
6	2.852	0.18	31.03	-	31.21	-	56.00	46.00	-24.79	-

- REMARKS:**
1. Q.P. and AV. are abbreviations of quasi-peak and average individually.
  2. "-": The Quasi-peak reading value also meets average limit and measurement with the average detector is unnecessary.
  3. The emission levels of other frequencies were very low against the limit.
  4. Margin value = Emission level - Limit value
  5. Correction factor = Insertion loss + Cable loss
  6. Emission Level = Correction Factor + Reading Value.

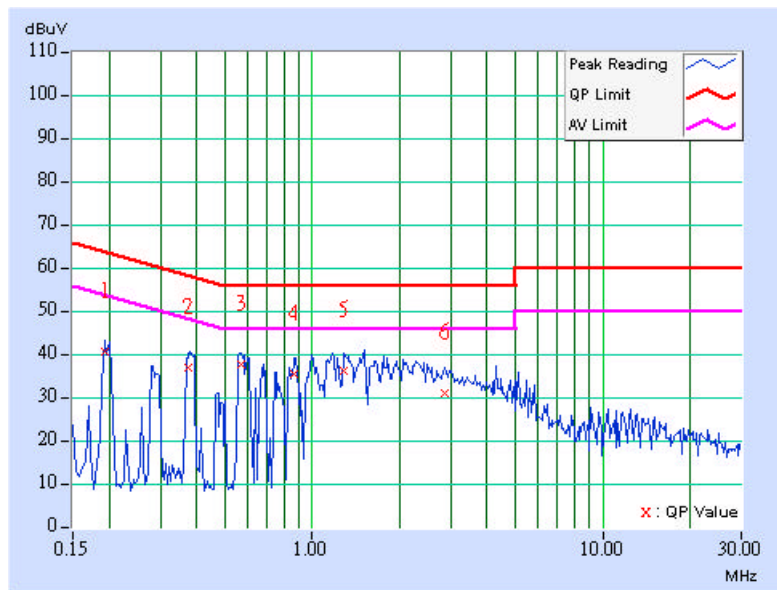



<b>EUT</b>	ADSL Modem with High-Speed Mode Wireless-G Router	<b>MODEL</b>	F5D7633-4
<b>CHANNEL</b>	6	<b>6dB BANDWIDTH</b>	9 kHz
<b>INPUT POWER (SYSTEM)</b>	120 Vac, 60 Hz	<b>PHASE</b>	Line (L)
<b>ENVIRONMENTAL CONDITIONS</b>	23 deg. C, 69% RH, 991 hPa	<b>TEST MODE</b>	2
<b>TESTED BY</b>	Steven Lu		

No	Freq. [MHz]	Corr. Factor (dB)	Reading Value [dB (uV)]		Emission Level [dB (uV)]		Limit [dB (uV)]		Margin (dB)	
			Q.P.	AV.	Q.P.	AV.	Q.P.	AV.	Q.P.	AV.
1	0.193	0.12	35.46	-	35.58	-	63.91	53.91	-28.33	-
2	0.392	0.13	37.18	-	37.31	-	58.02	48.02	-20.71	-
3	0.568	0.13	37.52	-	37.65	-	56.00	46.00	-18.35	-
4	0.916	0.15	36.06	-	36.21	-	56.00	46.00	-19.79	-
5	1.516	0.16	33.90	-	34.06	-	56.00	46.00	-21.94	-
6	4.441	0.22	27.15	-	27.37	-	56.00	46.00	-28.63	-

- REMARKS:**
1. Q.P. and AV. are abbreviations of quasi-peak and average individually.
  2. "-": The Quasi-peak reading value also meets average limit and measurement with the average detector is unnecessary.
  3. The emission levels of other frequencies were very low against the limit.
  4. Margin value = Emission level - Limit value
  5. Correction factor = Insertion loss + Cable loss
  6. Emission Level = Correction Factor + Reading Value.

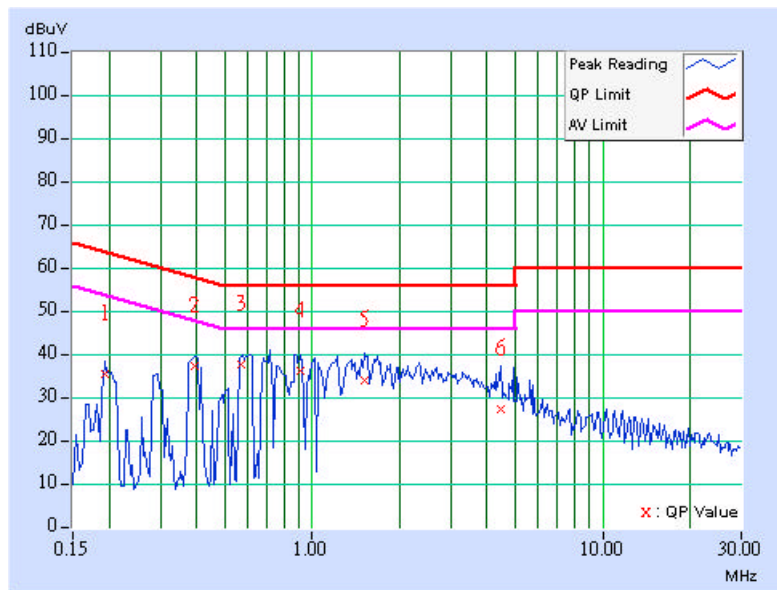



<b>EUT</b>	ADSL Modem with High-Speed Mode Wireless-G Router	<b>MODEL</b>	F5D7633-4
<b>CHANNEL</b>	6	<b>6dB BANDWIDTH</b>	9 kHz
<b>INPUT POWER (SYSTEM)</b>	120 Vac, 60 Hz	<b>PHASE</b>	Netural (N)
<b>ENVIRONMENTAL CONDITIONS</b>	23 deg. C, 69% RH, 991 hPa	<b>TEST MODE</b>	2
<b>TESTED BY</b>	Steven Lu		

No	Freq. [MHz]	Corr. Factor (dB)	Reading Value [dB (uV)]		Emission Level [dB (uV)]		Limit [dB (uV)]		Margin (dB)	
			Q.P.	AV.	Q.P.	AV.	Q.P.	AV.	Q.P.	AV.
			1	0.193	0.11	39.77	-	39.88	-	63.91
2	0.408	0.12	38.77	-	38.89	-	57.69	47.69	-18.81	-
3	0.591	0.12	37.22	-	37.34	-	56.00	46.00	-18.66	-
4	1.160	0.15	35.94	-	36.09	-	56.00	46.00	-19.91	-
5	1.543	0.16	36.65	-	36.81	-	56.00	46.00	-19.19	-
6	4.930	0.22	34.78	-	35.00	-	56.00	46.00	-21.00	-

- REMARKS:**
1. Q.P. and AV. are abbreviations of quasi-peak and average individually.
  2. "-": The Quasi-peak reading value also meets average limit and measurement with the average detector is unnecessary.
  3. The emission levels of other frequencies were very low against the limit.
  4. Margin value = Emission level - Limit value
  5. Correction factor = Insertion loss + Cable loss
  6. Emission Level = Correction Factor + Reading Value.

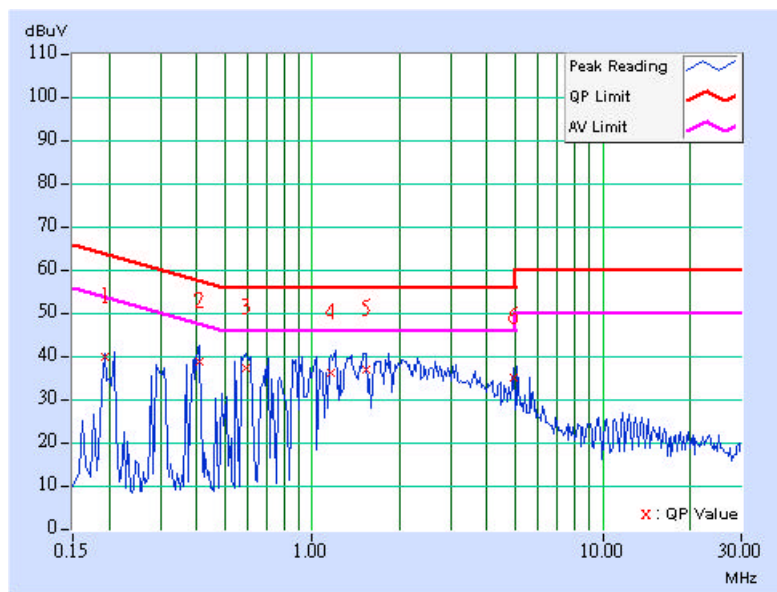





<b>EUT</b>	ADSL Modem with High-Speed Mode Wireless-G Router	<b>MODEL</b>	F5D7633-4
<b>CHANNEL</b>	11	<b>6dB BANDWIDTH</b>	9 kHz
<b>INPUT POWER (SYSTEM)</b>	120 Vac, 60 Hz	<b>PHASE</b>	Line (L)
<b>ENVIRONMENTAL CONDITIONS</b>	23 deg. C, 69% RH, 991 hPa	<b>TEST MODE</b>	2
<b>TESTED BY</b>	Steven Lu		

No	Freq. [MHz]	Corr. Factor [dB]	Reading Value [dB (uV)]		Emission Level [dB (uV)]		Limit [dB (uV)]		Margin (dB)	
			Q.P.	AV.	Q.P.	AV.	Q.P.	AV.	Q.P.	AV.
			1	0.185	0.12	33.63	-	33.75	-	64.25
2	0.400	0.13	37.11	-	37.24	-	57.85	47.85	-20.62	-
3	0.584	0.13	36.64	-	36.77	-	56.00	46.00	-19.23	-
4	0.873	0.14	36.52	-	36.66	-	56.00	46.00	-19.34	-
5	1.496	0.15	33.86	-	34.01	-	56.00	46.00	-21.99	-
6	4.906	0.23	33.51	-	33.74	-	56.00	46.00	-22.26	-

- REMARKS:**
1. Q.P. and AV. are abbreviations of quasi-peak and average individually.
  2. "-": The Quasi-peak reading value also meets average limit and measurement with the average detector is unnecessary.
  3. The emission levels of other frequencies were very low against the limit.
  4. Margin value = Emission level - Limit value
  5. Correction factor = Insertion loss + Cable loss
  6. Emission Level = Correction Factor + Reading Value.

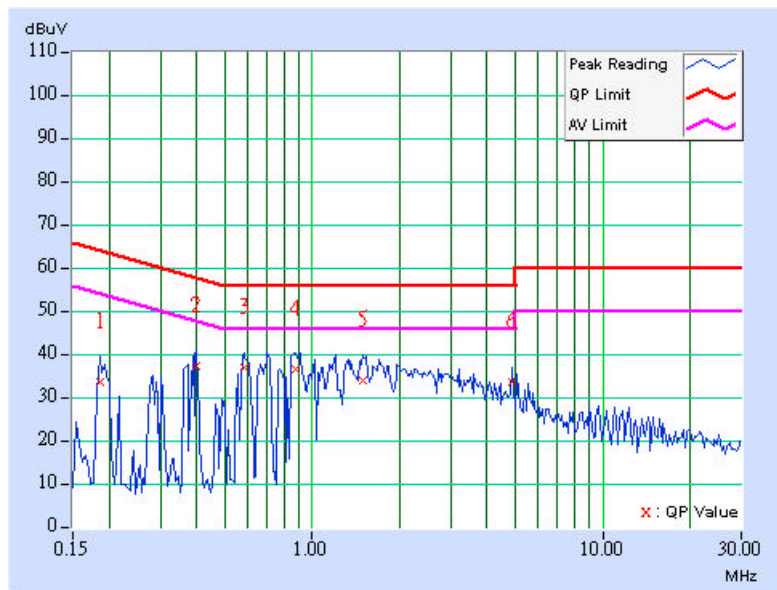



<b>EUT</b>	ADSL Modem with High-Speed Mode Wireless-G Router	<b>MODEL</b>	F5D7633-4
<b>CHANNEL</b>	11	<b>6dB BANDWIDTH</b>	9 kHz
<b>INPUT POWER (SYSTEM)</b>	120 Vac, 60 Hz	<b>PHASE</b>	Netural (N)
<b>ENVIRONMENTAL CONDITIONS</b>	23 deg. C, 69% RH, 991 hPa	<b>TEST MODE</b>	2
<b>TESTED BY</b>	Steven Lu		

No	Freq. [MHz]	Corr. Factor [dB]	Reading Value [dB (uV)]		Emission Level [dB (uV)]		Limit [dB (uV)]		Margin (dB)	
			Q.P.	AV.	Q.P.	AV.	Q.P.	AV.	Q.P.	AV.
			1	0.193	0.11	39.71	-	39.82	-	63.91
2	0.408	0.12	38.99	-	39.11	-	57.69	47.69	-18.59	-
3	0.603	0.12	36.90	-	37.02	-	56.00	46.00	-18.98	-
4	1.156	0.15	35.91	-	36.06	-	56.00	46.00	-19.94	-
5	1.504	0.16	35.85	-	36.01	-	56.00	46.00	-19.99	-
6	5.090	0.22	33.77	-	33.99	-	60.00	50.00	-26.01	-

- REMARKS:**
1. Q.P. and AV. are abbreviations of quasi-peak and average individually.
  2. "-": The Quasi-peak reading value also meets average limit and measurement with the average detector is unnecessary.
  3. The emission levels of other frequencies were very low against the limit.
  4. Margin value = Emission level - Limit value
  5. Correction factor = Insertion loss + Cable loss
  6. Emission Level = Correction Factor + Reading Value.

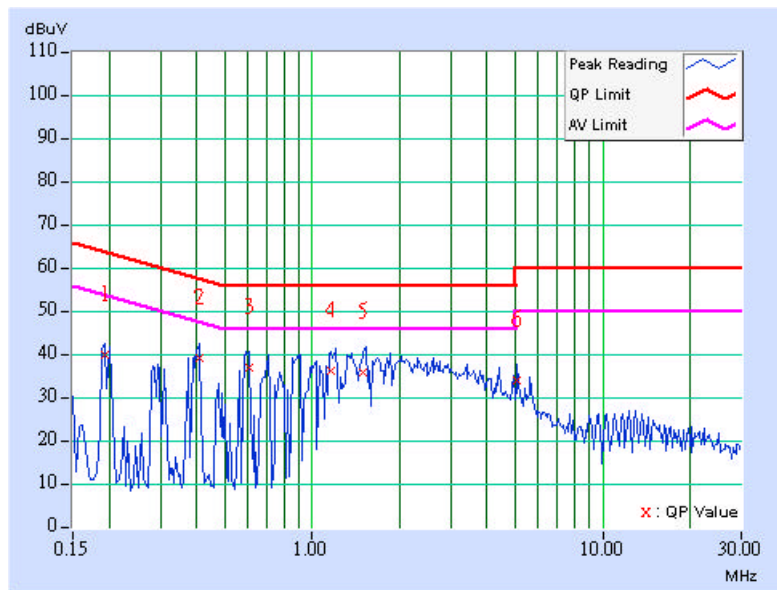



## 4.2 RADIATED EMISSION MEASUREMENT

### 4.2.1 LIMITS OF RADIATED EMISSION MEASUREMENT

Emissions radiated outside of the specified bands, shall be according to the general radiated limits in 15.209 as following:

Frequencies (MHz)	Field strength (microvolts/meter)	Measurement distance (meters)
0.009-0.490	2400/F(kHz)	300
0.490-1.705	24000/F(kHz)	30
1.705-30.0	30	30
30-88	100	3
88-216	150	3
216-960	200	3
Above 960	500	3

**NOTE:**

1. The lower limit shall apply at the transition frequencies.
2. Emission level (dBuV/m) = 20 log Emission level (uV/m).
3. As shown in 15.35(b), for frequencies above 1000MHz, the field strength limits are based on average detector, however, the peak field strength of any emission shall not exceed the maximum permitted average limits, specified above by more than 20dB under any condition of modulation.



## 4.2.2 TEST INSTRUMENTS

DESCRIPTION & MANUFACTURER	MODEL NO.	SERIAL NO.	CALIBRATED UNTIL
Test Receiver ROHDE & SCHWARZ	ESIB7	100188	Jan. 13, 2005
Spectrum Analyzer ROHDE & SCHWARZ	FSP40	100039	Nov. 21, 2005
BILOG Antenna SCHWARZBECK	VULB9168	9168-157	Feb. 03, 2005
HORN Antenna SCHWARZBECK	BBHA 9120 D	9120D-407	Feb. 03, 2005
HORN Antenna SCHWARZBECK	BBHA 9170	BBHA 9170241	Feb. 23, 2005
Preamplifier Agilent	8449B	3008A01961	Nov. 09, 2005
Preamplifier Agilent	8447D	2944A10629	Nov. 09, 2005
RF signal cable HUBER+SUHNER	SUCOFLEX 104	218182/4	Mar. 04, 2005
RF signal cable HUBER+SUHNER	SUCOFLEX 104	218194/4	Mar. 04, 2005
Software ADT.	ADT_Radiated_V5.14	NA	NA
Antenna Tower ADT.	AT100	AT93021702	NA
Turn Table ADT.	TT100.	TT93021702	NA
Controller ADT.	SC100.	SC93021702	NA

- NOTE:**
1. The calibration interval of the above test instruments is 12 months and the calibrations are traceable to NML/ROC and NIST/USA.
  2. The test was performed in HwaYa Chamber 1.
  3. The horn antenna and HP preamplifier (model: 8449B) are used only for the measurement of emission frequency above 1GHz if tested.
  4. The IC Site Registration No. is IC4924-2.



#### 4.2.3 TEST PROCEDURES

- a. The EUT was placed on the top of a rotating table 0.8 meters above the ground at a 3 meter semi-anechoic chamber. The table was rotated 360 degrees to determine the position of the highest radiation.
- b. The EUT was set 3 meters away from the interference-receiving antenna, which was mounted on the top of a variable-height antenna tower.
- c. The antenna is a broadband antenna, and its height is varied from one meter to four meters above the ground to determine the maximum value of the field strength. Both horizontal and vertical polarizations of the antenna are set to make the measurement.
- d. For each suspected emission, the EUT was arranged to its worst case and then the antenna was tuned to heights from 1 meter to 4 meters and the rotatable table was turned from 0 degrees to 360 degrees to find the maximum reading.
- e. The test-receiver system was set to Peak Detect Function and Specified Bandwidth with Maximum Hold Mode.
- f. If the emission level of the EUT in peak mode was 10 dB lower than the limit specified, then testing could be stopped and the peak values of the EUT would be reported. Otherwise the emissions that did not have 10 dB margin would be re-tested one by one using peak, quasi-peak or average method as specified and then reported in a data sheet.

**NOTE:**

1. The resolution bandwidth and video bandwidth of test receiver/spectrum analyzer is 120kHz for Peak detection (PK) and Quasi-peak detection (QP) at frequency below 1GHz.
2. The resolution bandwidth and video bandwidth of test receiver/spectrum analyzer is 1 MHz for Peak detection at frequency above 1GHz.
3. The resolution bandwidth of test receiver/spectrum analyzer is 1 MHz and the video bandwidth is 10 Hz for Average detection (AV) at frequency above 1GHz.

#### 4.2.4 DEVIATION FROM TEST STANDARD

No deviation

#### 4.2.5 TEST SETUP

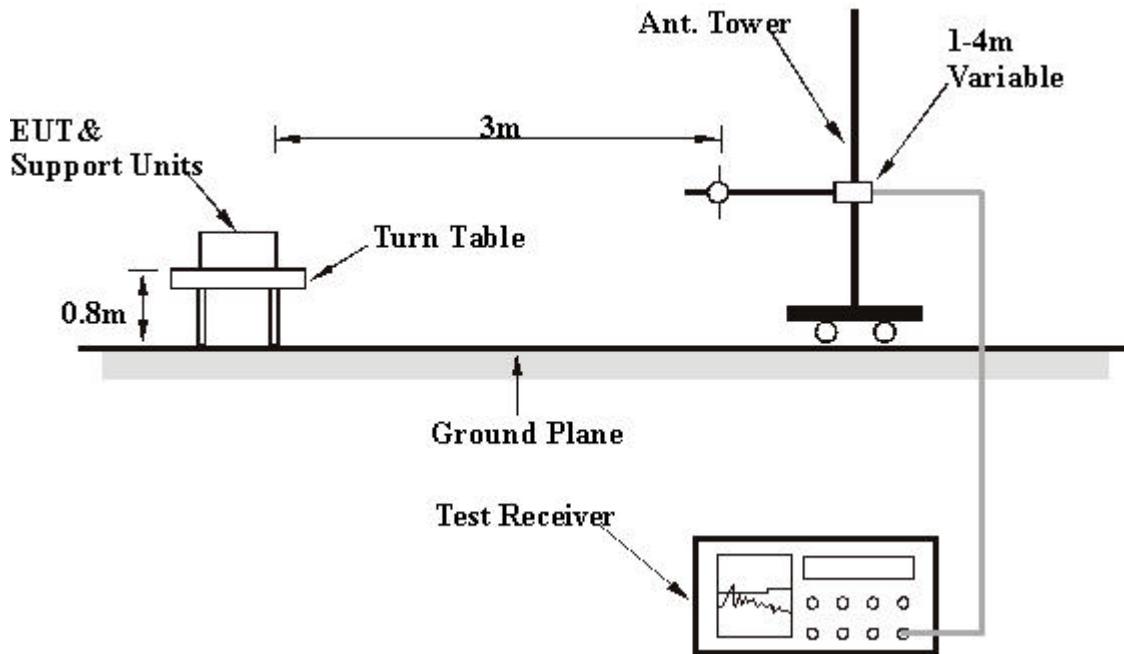

For the actual test configuration, please refer to the related item – Photographs of the Test Configuration.

#### 4.2.6 EUT OPERATING CONDITIONS

Same as 4.1.6



## 4.2.7 TEST RESULTS

<b>EUT</b>	ADSL Modem with High-Speed Mode Wireless-G Router	<b>MODEL</b>	F5D7633-4
<b>CHANNEL</b>	11	<b>FREQUENCY RANGE</b>	Below 1000 MHz
<b>INPUT POWER (SYSTEM)</b>	120 Vac, 60Hz	<b>DETECTOR FUNCTION</b>	Quasi-Peak
<b>ENVIRONMENTAL CONDITIONS</b>	25 deg. C, 60% RH, 991 hPa	<b>TEST MODE</b>	1
<b>TESTED BY</b>	Match Tsui		

**ANTENNA POLARITY & TEST DISTANCE: HORIZONTAL AT 3 M**

No.	Freq. (MHz)	Emission Level (dBuV/m)	Limit (dBuV/m)	Margin (dB)	Antenna Height (m)	Table Angle (Degree)	Raw Value (dBuV)	Correction Factor (dB/m)
1	92.20	34.06 QP	43.50	-9.44	1.75 H	283	23.69	10.37
2	127.19	41.40 QP	43.50	-2.10	1.50 H	97	27.87	13.53
3	232.16	34.27 QP	46.00	-11.73	1.00 H	46	21.68	12.59
4	249.66	39.72 QP	46.00	-6.28	1.00 H	49	26.50	13.22
5	300.20	38.52 QP	46.00	-7.48	1.25 H	232	24.02	14.50
6	374.07	38.28 QP	46.00	-7.72	1.00 H	214	22.11	16.18
7	399.34	37.73 QP	46.00	-8.27	1.00 H	229	21.00	16.74
8	500.42	41.41 QP	46.00	-4.59	1.75 H	58	22.67	18.74
9	512.08	38.01 QP	46.00	-7.99	1.50 H	214	19.05	18.96
10	599.56	40.77 QP	46.00	-5.23	1.25 H	193	19.77	21.00
11	624.83	37.00 QP	46.00	-9.00	1.00 H	118	15.65	21.34
12	640.38	44.80 QP	46.00	-1.20	1.25 H	328	23.24	21.55
13	700.64	35.56 QP	46.00	-10.44	1.00 H	187	13.24	22.32
14	768.68	42.96 QP	46.00	-3.04	1.00 H	136	19.33	23.64
15	799.78	37.17 QP	46.00	-8.83	1.00 H	196	13.36	23.82
16	896.97	38.56 QP	46.00	-7.44	1.50 H	178	13.50	25.05

- REMARKS:**
1. Emission level(dBuV/m)=Raw Value(dBuV) + Correction Factor(dB/m)
  2. Correction Factor(dB/m) = Antenna Factor (dB/m) + Cable Factor (dB)
  3. The other emission levels were very low against the limit.
  4. Margin value = Emission level – Limit value.



<b>EUT</b>	ADSL Modem with High-Speed Mode Wireless-G Router	<b>MODEL</b>	F5D7633-4
<b>CHANNEL</b>	11	<b>FREQUENCY RANGE</b>	Below 1000 MHz
<b>INPUT POWER (SYSTEM)</b>	120 Vac, 60Hz	<b>DETECTOR FUNCTION</b>	Quasi-Peak
<b>ENVIRONMENTAL CONDITIONS</b>	25 deg. C, 60% RH, 991 hPa	<b>TEST MODE</b>	1
<b>TESTED BY</b>	Match Tsui		

#### ANTENNA POLARITY & TEST DISTANCE: VERTICAL AT 3 M

No.	Freq. (MHz)	Emission Level (dBuV/m)	Limit (dBuV/m)	Margin (dB)	Antenna Height (m)	Table Angle (Degree)	Raw Value (dBuV)	Correction Factor (dB/m)
1	57.26	38.50 QP	40.00	-1.50	1.06 V	68	24.52	13.98
2	98.04	40.63 QP	43.50	-2.87	1.50 V	256	29.80	10.83
3	111.64	39.87 QP	43.50	-3.63	1.00 V	295	27.70	12.17
4	131.08	35.99 QP	43.50	-7.51	1.00 V	238	22.19	13.80
5	232.16	32.06 QP	46.00	-13.94	1.00 V	76	19.47	12.59
6	383.79	36.19 QP	46.00	-9.81	1.25 V	91	19.80	16.39
7	399.34	33.45 QP	46.00	-12.55	1.25 V	244	16.72	16.74
8	512.08	33.69 QP	46.00	-12.31	1.00 V	247	14.73	18.96
9	599.56	32.89 QP	46.00	-13.11	1.00 V	211	11.89	21.00
10	640.38	40.94 QP	46.00	-5.06	1.00 V	274	19.39	21.55
11	768.68	39.85 QP	46.00	-6.15	1.50 V	235	16.22	23.64
12	799.78	36.67 QP	46.00	-9.33	1.25 V	109	12.85	23.82
13	896.97	36.04 QP	46.00	-9.96	1.50 V	166	10.98	25.05

- REMARKS:**
1. Emission level(dBuV/m)=Raw Value(dBuV) + Correction Factor(dB/m)
  2. Correction Factor(dB/m) = Antenna Factor (dB/m) + Cable Factor (dB)
  3. The other emission levels were very low against the limit.
  4. Margin value = Emission level – Limit value.





<b>EUT</b>	ADSL Modem with High-Speed Mode Wireless-G Router	<b>MODEL</b>	F5D7633-4
<b>CHANNEL</b>	11	<b>FREQUENCY RANGE</b>	Below 1000 MHz
<b>INPUT POWER (SYSTEM)</b>	120 Vac, 60Hz	<b>DETECTOR FUNCTION</b>	Quasi-Peak
<b>ENVIRONMENTAL CONDITIONS</b>	22 deg. C, 60% RH, 991 hPa	<b>TEST MODE</b>	2
<b>TESTED BY</b>	Match Tsui		

#### ANTENNA POLARITY & TEST DISTANCE: HORIZONTAL AT 3 M

No.	Freq. (MHz)	Emission Level (dBuV/m)	Limit (dBuV/m)	Margin (dB)	Antenna Height (m)	Table Angle (Degree)	Raw Value (dBuV)	Correction Factor (dB/m)
1	59.16	27.21 QP	40.00	-12.79	1.00 H	358	13.42	13.79
2	105.81	26.40 QP	43.50	-17.10	1.50 H	67	14.82	11.58
3	160.24	30.90 QP	43.50	-12.60	1.50 H	28	16.03	14.87
4	232.16	32.81 QP	46.00	-13.19	1.00 H	130	20.22	12.59
5	267.15	30.18 QP	46.00	-15.82	1.00 H	238	16.53	13.66
6	300.20	33.65 QP	46.00	-12.35	1.00 H	358	19.15	14.50
7	333.25	28.94 QP	46.00	-17.06	1.00 H	136	13.68	15.26
8	374.07	36.77 QP	46.00	-9.23	1.00 H	4	20.59	16.18
9	500.42	34.98 QP	46.00	-11.02	1.50 H	358	16.24	18.74
10	599.56	33.09 QP	46.00	-12.91	1.50 H	325	12.09	21.00
11	640.38	39.91 QP	46.00	-6.09	1.00 H	346	18.36	21.55
12	700.64	36.15 QP	46.00	-9.85	1.00 H	7	13.83	22.32
13	768.68	36.98 QP	46.00	-9.02	1.00 H	358	13.34	23.64
14	799.78	33.46 QP	46.00	-12.54	1.00 H	337	9.65	23.82
15	896.97	33.82 QP	46.00	-12.18	1.00 H	265	8.76	25.05

- REMARKS:**
1. Emission level(dBuV/m)=Raw Value(dBuV) + Correction Factor(dB/m)
  2. Correction Factor(dB/m) = Antenna Factor (dB/m) + Cable Factor (dB)
  3. The other emission levels were very low against the limit.
  4. Margin value = Emission level – Limit value.



<b>EUT</b>	ADSL Modem with High-Speed Mode Wireless-G Router	<b>MODEL</b>	F5D7633-4
<b>CHANNEL</b>	11	<b>FREQUENCY RANGE</b>	Below 1000 MHz
<b>INPUT POWER (SYSTEM)</b>	120 Vac, 60Hz	<b>DETECTOR FUNCTION</b>	Quasi-Peak
<b>ENVIRONMENTAL CONDITIONS</b>	22 deg. C, 60% RH, 991 hPa	<b>TEST MODE</b>	2
<b>TESTED BY</b>	Match Tsui		

#### ANTENNA POLARITY & TEST DISTANCE: VERTICAL AT 3 M

No.	Freq. (MHz)	Emission Level (dBuV/m)	Limit (dBuV/m)	Margin (dB)	Antenna Height (m)	Table Angle (Degree)	Raw Value (dBuV)	Correction Factor (dB/m)
1	59.16	38.56 QP	40.00	-1.44	1.00 V	223	24.77	13.79
2	105.81	33.08 QP	43.50	-10.42	1.00 V	70	21.50	11.58
3	146.63	35.07 QP	43.50	-8.43	1.00 V	61	20.49	14.58
4	166.07	34.29 QP	43.50	-9.21	1.00 V	265	19.98	14.30
5	232.16	30.77 QP	46.00	-15.23	1.00 V	4	18.18	12.59
6	300.20	34.49 QP	46.00	-11.51	1.50 V	298	19.99	14.50
7	374.07	34.52 QP	46.00	-11.48	1.50 V	334	18.34	16.18
8	399.34	31.86 QP	46.00	-14.14	1.50 V	331	15.13	16.74
9	500.42	34.96 QP	46.00	-11.04	1.00 V	16	16.22	18.74
10	599.56	31.06 QP	46.00	-14.94	1.00 V	262	10.06	21.00
11	640.38	36.58 QP	46.00	-9.42	1.00 V	265	15.03	21.55
12	768.68	34.87 QP	46.00	-11.13	1.50 V	64	11.23	23.64
13	799.78	30.01 QP	46.00	-15.99	1.50 V	256	6.19	23.82
14	896.97	31.44 QP	46.00	-14.56	1.50 V	172	6.39	25.05

- REMARKS:**
1. Emission level(dBuV/m)=Raw Value(dBuV) + Correction Factor(dB/m)
  2. Correction Factor(dB/m) = Antenna Factor (dB/m) + Cable Factor (dB)
  3. The other emission levels were very low against the limit.
  4. Margin value = Emission level – Limit value.



## 4.2.8 TEST RESULTS (A)

<b>EUT</b>	ADSL Modem with High-Speed Mode Wireless-G Router	<b>MODEL</b>	F5D7633-4
<b>CHANNEL</b>	1	<b>FREQUENCY RANGE</b>	1~25 GHz
<b>INPUT POWER (SYSTEM)</b>	120 Vac, 60 Hz	<b>DETECTOR FUNCTION</b>	Peak (PK) Average (AV)
<b>ENVIRONMENTAL CONDITIONS</b>	25 deg. C, 60% RH, 991 hPa	<b>TESTED BY</b>	Match Tsui

**ANTENNA POLARITY & TEST DISTANCE: HORIZONTAL AT 3 M**

No.	Freq. (MHz)	Emission Level (dBuV/m)	Limit (dBuV/m)	Margin (dB)	Antenna Height (m)	Table Angle (Degree)	Raw Value (dBuV)	Correction Factor (dB/m)
1	1608.00	44.38 PK	74.00	-29.62	1.14 H	71	15.71	28.67
1	1608.00	39.48 AV	54.00	-14.52	1.14 H	71	10.81	28.67
2	1792.00	45.93 PK	74.00	-28.07	1.07 H	277	16.30	29.62
2	1792.00	43.40 AV	54.00	-10.60	1.07 H	277	13.77	29.62
3	2390.00	50.43 PK	74.00	-23.57	1.25 H	20	18.63	31.80
3	2390.00	44.06 AV	54.00	-9.94	1.25 H	20	12.26	31.80
4	*2412.00	104.80 PK			1.25 H	20	72.93	31.87
4	*2412.00	98.43 AV			1.25 H	20	66.56	31.87
5	4824.00	48.52 PK	74.00	-25.48	1.07 H	220	10.41	38.11
5	4824.00	36.67 AV	54.00	-17.33	1.07 H	220	-1.44	38.11

**ANTENNA POLARITY & TEST DISTANCE: VERTICAL AT 3 M**

No.	Freq. (MHz)	Emission Level (dBuV/m)	Limit (dBuV/m)	Margin (dB)	Antenna Height (m)	Table Angle (Degree)	Raw Value (dBuV)	Correction Factor (dB/m)
1	1608.00	50.19 PK	74.00	-23.81	1.00 V	104	21.52	28.67
1	1608.00	46.03 AV	54.00	-7.97	1.00 V	104	17.36	28.67
2	1792.00	49.35 PK	74.00	-24.65	1.00 V	353	19.72	29.62
3	2390.00	57.42 PK	74.00	-16.58	1.29 V	58	25.62	31.80
3	2390.00	50.38 AV	54.00	-3.62	1.29 V	58	18.58	31.80
4	*2412.00	111.79 PK			1.29 V	58	79.92	31.87
4	*2412.00	104.75 AV			1.29 V	58	72.88	31.87
5	4824.00	52.41 PK	74.00	-21.59	1.12 V	205	14.30	38.11
5	4824.00	47.05 AV	54.00	-6.95	1.12 V	205	8.94	38.11
6	9648.00	53.16 PK	74.00	-20.84	1.07 V	93	10.88	42.28
6	9648.00	46.12 AV	54.00	-7.88	1.07 V	93	3.84	42.28

**REMARKS:**

1. Emission level(dBuV/m)=Raw Value(dBuV) + Correction Factor(dB)
2. Correction Factor(dB/m) = Antenna Factor (dB/m) + Cable Factor (dB)
3. The other emission levels were very low against the limit.
4. Margin value = Emission level – Limit value.
5. “ \* “ : Fundamental frequency



<b>EUT</b>	ADSL Modem with High-Speed Mode Wireless-G Router	<b>MODEL</b>	F5D7633-4
<b>CHANNEL</b>	6	<b>FREQUENCY RANGE</b>	1~25 GHz
<b>INPUT POWER (SYSTEM)</b>	120 Vac, 60 Hz	<b>DETECTOR FUNCTION</b>	Peak (PK) Average (AV)
<b>ENVIRONMENTAL CONDITIONS</b>	25 deg. C, 60% RH, 991 hPa	<b>TESTED BY</b>	Match Tsui

#### ANTENNA POLARITY & TEST DISTANCE: HORIZONTAL AT 3 M

No.	Freq. (MHz)	Emission Level (dBuV/m)	Limit (dBuV/m)	Margin (dB)	Antenna Height (m)	Table Angle (Degree)	Raw Value (dBuV)	Correction Factor (dB/m)
1	1624.00	45.36 PK	74.00	-28.64	1.15 H	212	16.60	28.76
1	1624.00	40.31 AV	54.00	-13.69	1.15 H	212	11.55	28.76
2	1792.00	47.46 PK	74.00	-26.54	1.11 H	301	17.83	29.62
2	1792.00	43.77 AV	54.00	-10.23	1.11 H	301	14.14	29.62
3	*2437.00	103.04 PK			1.00 H	357	71.09	31.95
3	*2437.00	96.59 AV			1.00 H	357	64.64	31.95
4	4874.00	48.65 PK	74.00	-25.35	1.00 H	60	10.37	38.28
4	4874.00	36.16 AV	54.00	-17.84	1.00 H	60	-2.12	38.28

#### ANTENNA POLARITY & TEST DISTANCE: VERTICAL AT 3 M

No.	Freq. (MHz)	Emission Level (dBuV/m)	Limit (dBuV/m)	Margin (dB)	Antenna Height (m)	Table Angle (Degree)	Raw Value (dBuV)	Correction Factor (dB/m)
1	1624.00	48.68 PK	74.00	-25.32	1.00 V	93	19.92	28.76
1	1624.00	46.29 AV	54.00	-7.71	1.00 V	93	17.53	28.76
2	1792.00	48.86 PK	74.00	-25.14	1.34 V	5	19.23	29.62
2	1792.00	45.82 AV	54.00	-8.18	1.34 V	5	16.19	29.62
3	*2437.00	111.40 PK			1.24 V	58	79.45	31.95
3	*2437.00	104.99 AV			1.24 V	58	73.04	31.95
4	4874.00	54.12 PK	74.00	-19.88	1.20 V	204	15.84	38.28
4	4874.00	49.06 AV	54.00	-4.94	1.20 V	204	10.78	38.28
5	9748.00	50.37 PK	74.00	-23.63	1.41 V	55	11.86	38.51
5	9748.00	40.92 AV	54.00	-13.08	1.41 V	55	2.41	38.51

#### REMARKS:

1. Emission level(dBuV/m)=Raw Value(dBuV) + Correction Factor(dB)
2. Correction Factor(dB/m) = Antenna Factor (dB/m) + Cable Factor (dB)
3. The other emission levels were very low against the limit.
4. Margin value = Emission level – Limit value.
5. “ \* “ : Fundamental frequency



<b>EUT</b>	ADSL Modem with High-Speed Mode Wireless-G Router	<b>MODEL</b>	F5D7633-4
<b>CHANNEL</b>	11	<b>FREQUENCY RANGE</b>	1~25 GHz
<b>INPUT POWER (SYSTEM)</b>	120 Vac, 60 Hz	<b>DETECTOR FUNCTION</b>	Peak (PK) Average (AV)
<b>ENVIRONMENTAL CONDITIONS</b>	25 deg. C, 60% RH, 991 hPa	<b>TESTED BY</b>	Match Tsui

### ANTENNA POLARITY & TEST DISTANCE: HORIZONTAL AT 3 M

No.	Freq. (MHz)	Emission Level (dBuV/m)	Limit (dBuV/m)	Margin (dB)	Antenna Height (m)	Table Angle (Degree)	Raw Value (dBuV)	Correction Factor (dB/m)
1	1641.00	44.46 PK	74.00	-29.54	1.39 H	120	15.61	28.85
1	1641.00	39.16 AV	54.00	-14.84	1.39 H	120	10.31	28.85
2	1792.00	47.37 PK	74.00	-26.63	1.09 H	302	17.74	29.62
2	1792.00	43.79 AV	54.00	-10.21	1.09 H	302	14.16	29.62
3	*2462.00	103.68 PK			1.00 H	318	71.66	32.02
3	*2462.00	96.79 AV			1.00 H	318	64.77	32.02
4	2483.50	49.28 PK	74.00	-24.72	1.00 H	318	17.19	32.09
4	2483.50	42.39 AV	54.00	-11.61	1.00 H	318	10.30	32.09
5	4924.00	48.92 PK	74.00	-25.08	1.17 H	1	10.43	38.49
5	4924.00	35.97 AV	54.00	-18.03	1.17 H	1	-2.52	38.49

### ANTENNA POLARITY & TEST DISTANCE: VERTICAL AT 3 M

No.	Freq. (MHz)	Emission Level (dBuV/m)	Limit (dBuV/m)	Margin (dB)	Antenna Height (m)	Table Angle (Degree)	Raw Value (dBuV)	Correction Factor (dB/m)
1	1641.00	50.57 PK	74.00	-23.43	1.00 V	94	21.72	28.85
1	1641.00	47.16 AV	54.00	-6.84	1.00 V	94	18.31	28.85
2	1792.00	47.75 PK	74.00	-26.25	1.34 V	5	18.12	29.62
2	1792.00	46.03 AV	54.00	-7.97	1.34 V	5	16.40	29.62
3	*2462.00	112.66 PK			1.07 V	360	80.64	32.02
3	*2462.00	105.65 AV			1.07 V	360	73.63	32.02
4	2483.50	58.26 PK	74.00	-15.74	1.07 V	360	26.17	32.09
4	2483.50	51.25 AV	54.00	-2.75	1.07 V	360	19.16	32.09
5	4924.00	53.28 PK	74.00	-20.72	1.12 V	137	14.79	38.49
5	4924.00	47.24 AV	54.00	-6.76	1.12 V	137	8.75	38.49
6	9848.00	47.04 PK	74.00	-26.96	1.02 V	343	11.71	35.33
6	9848.00	43.51 AV	54.00	-10.49	1.02 V	343	8.18	35.33

#### REMARKS:

1. Emission level(dBuV/m)=Raw Value(dBuV) + Correction Factor(dB)
2. Correction Factor(dB/m) = Antenna Factor (dB/m) + Cable Factor (dB)
3. The other emission levels were very low against the limit.
4. Margin value = Emission level – Limit value.
5. “ \* “ : Fundamental frequency



## 4.2.9 TEST RESULTS (B)

<b>EUT</b>	ADSL Modem with High-Speed Mode Wireless-G Router	<b>MODEL</b>	F5D7633-4
<b>CHANNEL</b>	1	<b>FREQUENCY RANGE</b>	1~25 GHz
<b>INPUT POWER (SYSTEM)</b>	120 Vac, 60 Hz	<b>DETECTOR FUNCTION</b>	Peak (PK) Average (AV)
<b>ENVIRONMENTAL CONDITIONS</b>	25 deg. C, 60% RH, 991 hPa	<b>TESTED BY</b>	Match Tsui

**ANTENNA POLARITY & TEST DISTANCE: HORIZONTAL AT 3 M**

No.	Freq. (MHz)	Emission Level (dBuV/m)	Limit (dBuV/m)	Margin (dB)	Antenna Height (m)	Table Angle (Degree)	Raw Value (dBuV)	Correction Factor (dB/m)
1	1608.00	45.45 PK	74.00	-28.55	1.23 H	214	16.78	28.67
1	1608.00	40.45 AV	54.00	-13.55	1.23 H	214	11.78	28.67
2	1792.00	45.96 PK	74.00	-28.04	1.17 H	87	16.33	29.62
2	1792.00	41.97 AV	54.00	-12.03	1.17 H	87	12.34	28.62
3	2390.00	51.06 PK	74.00	-22.94	1.25 H	20	19.26	31.80
3	2390.00	44.43 AV	54.00	-9.57	1.25 H	20	12.63	31.80
4	*2412.00	102.30 PK			1.25 H	20	70.43	31.87
4	*2412.00	95.67 AV			1.25 H	20	63.80	31.87
5	4824.00	49.45 PK	74.00	-24.55	1.17 H	172	11.34	38.11
5	4824.00	36.87 AV	54.00	-17.13	1.17 H	172	-1.24	38.11

**ANTENNA POLARITY & TEST DISTANCE: VERTICAL AT 3 M**

No.	Freq. (MHz)	Emission Level (dBuV/m)	Limit (dBuV/m)	Margin (dB)	Antenna Height (m)	Table Angle (Degree)	Raw Value (dBuV)	Correction Factor (dB/m)
1	1608.00	50.17 PK	74.00	-23.83	1.00 V	101	21.50	28.67
1	1608.00	46.10 AV	54.00	-7.90	1.00 V	101	17.43	28.67
2	1792.00	48.82 PK	74.00	-25.18	1.00 V	327	19.19	29.62
2	1792.00	45.77 AV	54.00	-8.23	1.00 V	327	16.14	29.62
3	2390.00	58.37 PK	74.00	-15.63	1.10 V	360	26.57	31.80
<b>3</b>	<b>2390.00</b>	<b>52.83 AV</b>	<b>54.00</b>	<b>-1.17</b>	<b>1.10 V</b>	<b>360</b>	<b>21.03</b>	<b>31.80</b>
4	*2412.00	109.61 PK			1.10 V	360	77.74	31.87
4	*2412.00	104.07 AV			1.10 V	360	72.20	31.87
5	4824.00	49.96 PK	74.00	-24.04	1.00 V	32	11.85	38.11
5	4824.00	41.89 AV	54.00	-12.11	1.00 V	32	3.78	38.11

**REMARKS:**

1. Emission level(dBuV/m)=Raw Value(dBuV) + Correction Factor(dB)
2. Correction Factor(dB/m) = Antenna Factor (dB/m) + Cable Factor (dB)
3. The other emission levels were very low against the limit.
4. Margin value = Emission level – Limit value.
5. “ \* ” : Fundamental frequency



<b>EUT</b>	ADSL Modem with High-Speed Mode Wireless-G Router	<b>MODEL</b>	F5D7633-4
<b>CHANNEL</b>	6	<b>FREQUENCY RANGE</b>	1~25 GHz
<b>INPUT POWER (SYSTEM)</b>	120 Vac, 60 Hz	<b>DETECTOR FUNCTION</b>	Peak (PK) Average (AV)
<b>ENVIRONMENTAL CONDITIONS</b>	25 deg. C, 60% RH, 991 hPa	<b>TESTED BY</b>	Match Tsui

#### ANTENNA POLARITY & TEST DISTANCE: HORIZONTAL AT 3 M

No.	Freq. (MHz)	Emission Level (dBuV/m)	Limit (dBuV/m)	Margin (dB)	Antenna Height (m)	Table Angle (Degree)	Raw Value (dBuV)	Correction Factor (dB/m)
1	1624.00	46.96 PK	74.00	-27.04	1.16 H	47	18.20	28.76
1	1624.00	41.45 AV	54.00	-12.55	1.16 H	47	12.69	28.76
2	1792.00	45.97 PK	74.00	-28.03	1.11 H	276	16.34	29.62
2	1792.00	42.14 AV	54.00	-11.86	1.11 H	276	12.51	29.62
3	*2437.00	102.46 PK			1.00 H	357	70.51	31.95
3	*2437.00	95.22 AV			1.00 H	357	63.27	31.95
4	4874.00	49.27 PK	74.00	-24.73	1.00 H	77	10.99	38.28
4	4874.00	35.83 AV	54.00	-18.17	1.00 H	77	-2.45	38.28

#### ANTENNA POLARITY & TEST DISTANCE: VERTICAL AT 3 M

No.	Freq. (MHz)	Emission Level (dBuV/m)	Limit (dBuV/m)	Margin (dB)	Antenna Height (m)	Table Angle (Degree)	Raw Value (dBuV)	Correction Factor (dB/m)
1	1624.00	49.44 PK	74.00	-24.56	1.00 V	94	20.68	28.76
1	1624.00	45.83 AV	54.00	-8.17	1.00 V	94	17.07	28.76
2	1792.00	47.91 PK	74.00	-26.09	1.26 V	360	18.28	29.62
2	1792.00	45.33 AV	54.00	-8.67	1.26 V	360	15.70	29.62
3	*2437.00	108.09 PK			1.07 V	90	76.14	31.95
3	*2437.00	102.18 AV			1.07 V	90	70.23	31.95
4	4874.00	49.33 PK	74.00	-24.67	1.13 V	185	11.05	38.28
4	4874.00	44.03 AV	54.00	-9.97	1.13 V	185	5.75	38.28

#### REMARKS:

1. Emission level(dBuV/m)=Raw Value(dBuV) + Correction Factor(dB)
2. Correction Factor(dB/m) = Antenna Factor (dB/m) + Cable Factor (dB)
3. The other emission levels were very low against the limit.
4. Margin value = Emission level – Limit value.
5. " \* " : Fundamental frequency



<b>EUT</b>	ADSL Modem with High-Speed Mode Wireless-G Router	<b>MODEL</b>	F5D7633-4
<b>CHANNEL</b>	11	<b>FREQUENCY RANGE</b>	1~25 GHz
<b>INPUT POWER (SYSTEM)</b>	120 Vac, 60 Hz	<b>DETECTOR FUNCTION</b>	Peak (PK) Average (AV)
<b>ENVIRONMENTAL CONDITIONS</b>	25 deg. C, 60% RH, 991 hPa	<b>TESTED BY</b>	Match Tsui

### ANTENNA POLARITY & TEST DISTANCE: HORIZONTAL AT 3 M

No.	Freq. (MHz)	Emission Level (dBuV/m)	Limit (dBuV/m)	Margin (dB)	Antenna Height (m)	Table Angle (Degree)	Raw Value (dBuV)	Correction Factor (dB/m)
1	1641.00	45.14 PK	74.00	-28.86	1.20 H	211	16.29	28.85
1	1641.00	40.47 AV	54.00	-13.53	1.20 H	211	11.62	28.85
2	1792.00	47.33 PK	74.00	-26.67	1.11 H	302	17.70	29.62
2	1792.00	44.34 AV	54.00	-9.66	1.11 H	302	14.71	29.62
3	*2462.00	101.58 PK			1.23 H	21	69.56	32.02
3	*2462.00	95.36 AV			1.23 H	21	63.34	32.02
4	2483.50	51.61 PK	74.00	-22.39	1.23 H	21	19.52	32.09
4	2483.50	45.39 AV	54.00	-8.61	1.23 H	21	13.30	32.09
5	4924.00	49.47 PK	74.00	-24.53	1.00 H	324	10.98	38.49
5	4924.00	36.29 AV	54.00	-17.71	1.00 H	324	-2.20	38.49

### ANTENNA POLARITY & TEST DISTANCE: VERTICAL AT 3 M

No.	Freq. (MHz)	Emission Level (dBuV/m)	Limit (dBuV/m)	Margin (dB)	Antenna Height (m)	Table Angle (Degree)	Raw Value (dBuV)	Correction Factor (dB/m)
1	1641.00	51.14 PK	74.00	-22.86	1.00 V	96	22.29	28.85
1	1641.00	48.19 AV	54.00	-5.81	1.00 V	96	19.34	28.85
2	1792.00	49.08 PK	74.00	-24.92	1.34 V	6	19.45	29.62
2	1792.00	46.00 AV	54.00	-8.00	1.34 V	6	16.37	29.62
3	*2462.00	108.50 PK			1.00 V	49	76.48	32.02
3	*2462.00	102.48 AV			1.00 V	49	70.46	32.02
4	2483.50	58.53 PK	74.00	-15.47	1.34 V	6	26.44	32.09
4	2483.50	52.51 AV	54.00	-1.49	1.34 V	6	20.42	32.09
5	4924.00	49.68 PK	74.00	-24.32	1.12 V	113	11.19	38.49
5	4924.00	41.38 AV	54.00	-12.62	1.12 V	113	2.89	38.49

#### REMARKS:

1. Emission level(dBuV/m)=Raw Value(dBuV) + Correction Factor(dB)
2. Correction Factor(dB/m) = Antenna Factor (dB/m) + Cable Factor (dB)
3. The other emission levels were very low against the limit.
4. Margin value = Emission level – Limit value.
5. “ \* “ : Fundamental frequency





### 4.3 6dB BANDWIDTH MEASUREMENT

#### 4.3.1 LIMITS OF 6dB BANDWIDTH MEASUREMENT

The minimum of 6dB Bandwidth Measurement is 0.5MHz.

#### 4.3.2 TEST INSTRUMENTS

Description & Manufacturer	Model No.	Serial No.	Calibrated Until
SPECTRUM ANALYZER	FSEK30	100049	Aug. 12, 2005

**NOTE:**

The calibration interval of the above test instruments is 12 months and the calibrations are traceable to NML/ROC and NIST/USA.

#### 4.3.3 TEST PROCEDURE

The transmitter output was connected to the spectrum analyzer through an attenuator. The bandwidth of the fundamental frequency was measured by spectrum analyzer with 100kHz RBW and 100kHz VBW. The 6dB bandwidth is defined as the total spectrum the power of which is higher than peak power minus 6dB.

#### 4.3.4 DEVIATION FROM TEST STANDARD

No deviation

#### 4.3.5 TEST SETUP

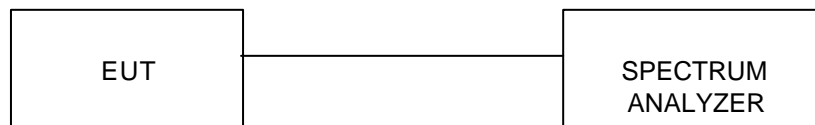

For the actual test configuration, please refer to the related Item – Photographs of the Test Configuration.

#### 4.3.6 EUT OPERATING CONDITIONS

The software provided by client to enable the EUT under transmission condition continuously at lowest, middle and highest channel frequencies individually.



## 4.3.7 TEST RESULTS (A)

<b>EUT</b>	ADSL Modem with High-Speed Mode Wireless-G Router	<b>MODEL</b>	F5D7633-4
<b>INPUT POWER (SYSTEM)</b>	120 Vac, 60 Hz	<b>ENVIRONMENTAL CONDITIONS</b>	24 deg. C, 64% RH, 991 hPa
<b>TESTED BY</b>	Leo Hung		

<b>CHANNEL</b>	<b>CHANNEL FREQUENCY (MHz)</b>	<b>6dB BANDWIDTH (MHz)</b>	<b>MINIMUM LIMIT (MHz)</b>	<b>PASS/FAIL</b>
1	2412	10.70	0.5	PASS
6	2437	10.58	0.5	PASS
11	2462	10.54	0.5	PASS



CH1

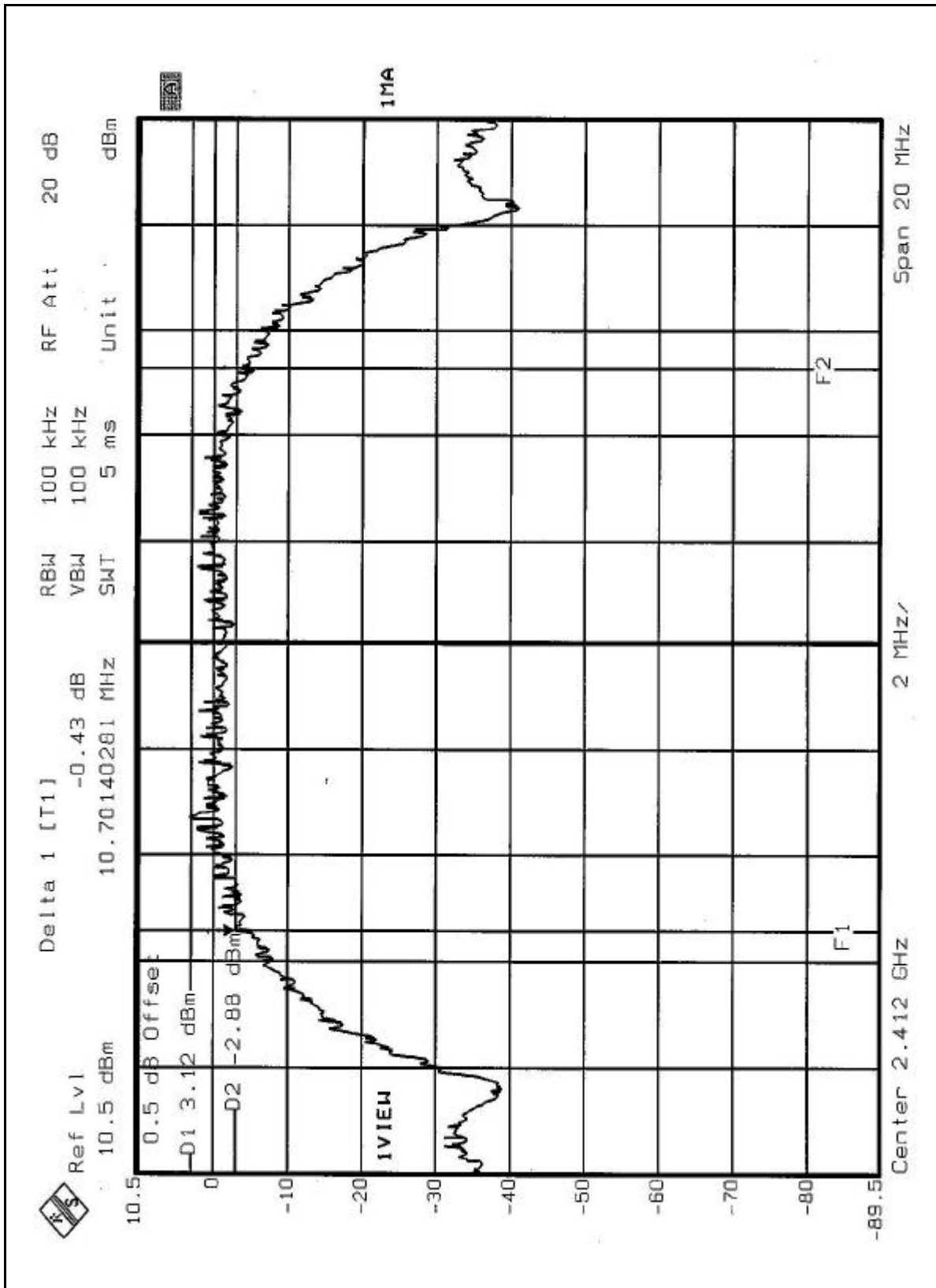



CH6

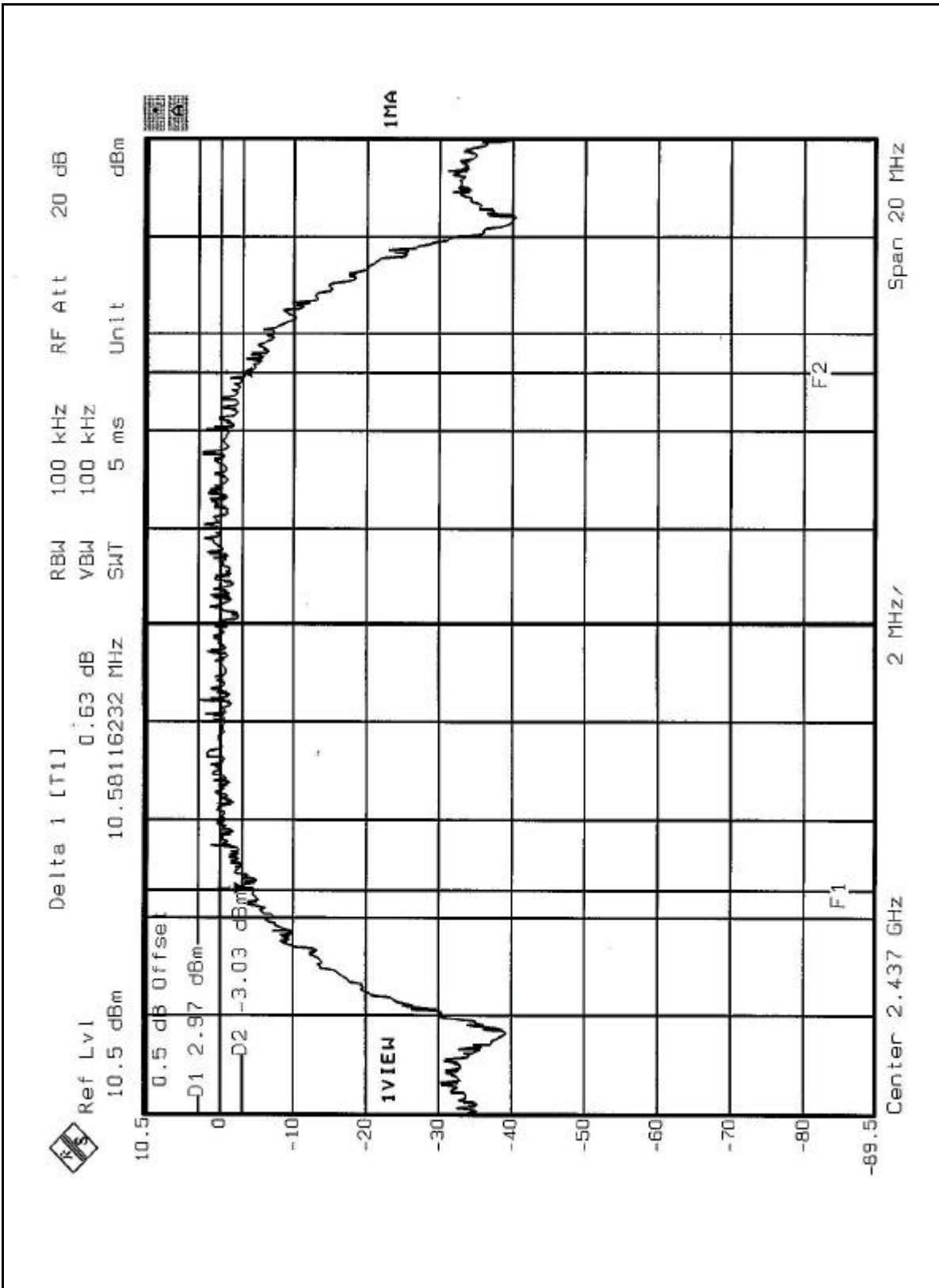



CH11

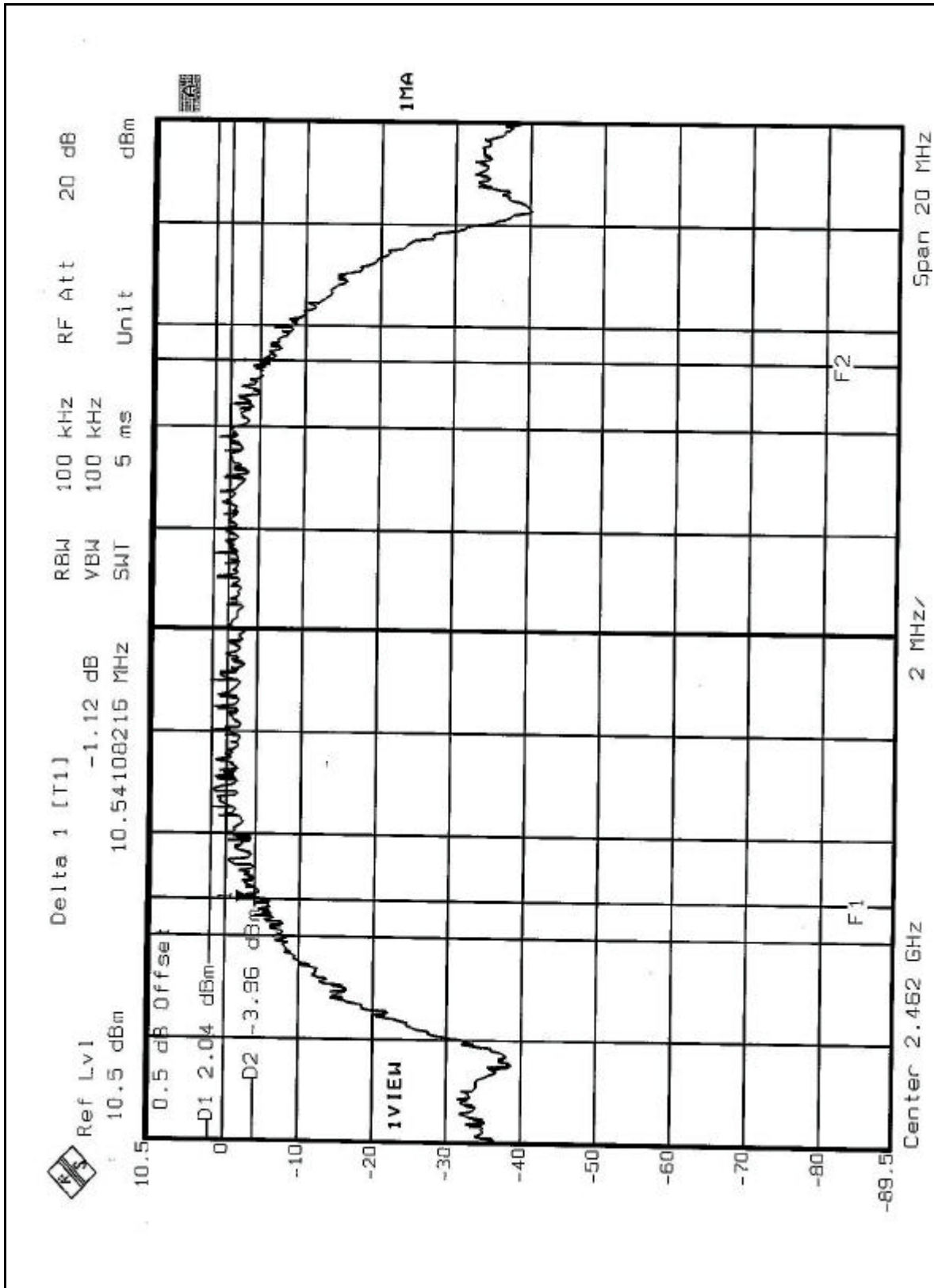



4.3.8 TEST RESULTS (B)

<b>EUT</b>	ADSL Modem with High-Speed Mode Wireless-G Router	<b>MODEL</b>	F5D7633-4
<b>INPUT POWER (SYSTEM)</b>	120 Vac, 60 Hz	<b>ENVIRONMENTAL CONDITIONS</b>	24 deg. C, 64% RH, 991 hPa
<b>TESTED BY</b>	Leo Hung		

<b>CHANNEL</b>	<b>CHANNEL FREQUENCY (MHz)</b>	<b>6 dB BANDWIDTH (MHz)</b>	<b>MINIMUM LIMIT (MHz)</b>	<b>PASS/FAIL</b>
1	2412	16.43	0.5	PASS
6	2437	16.39	0.5	PASS
11	2462	16.47	0.5	PASS



CH1

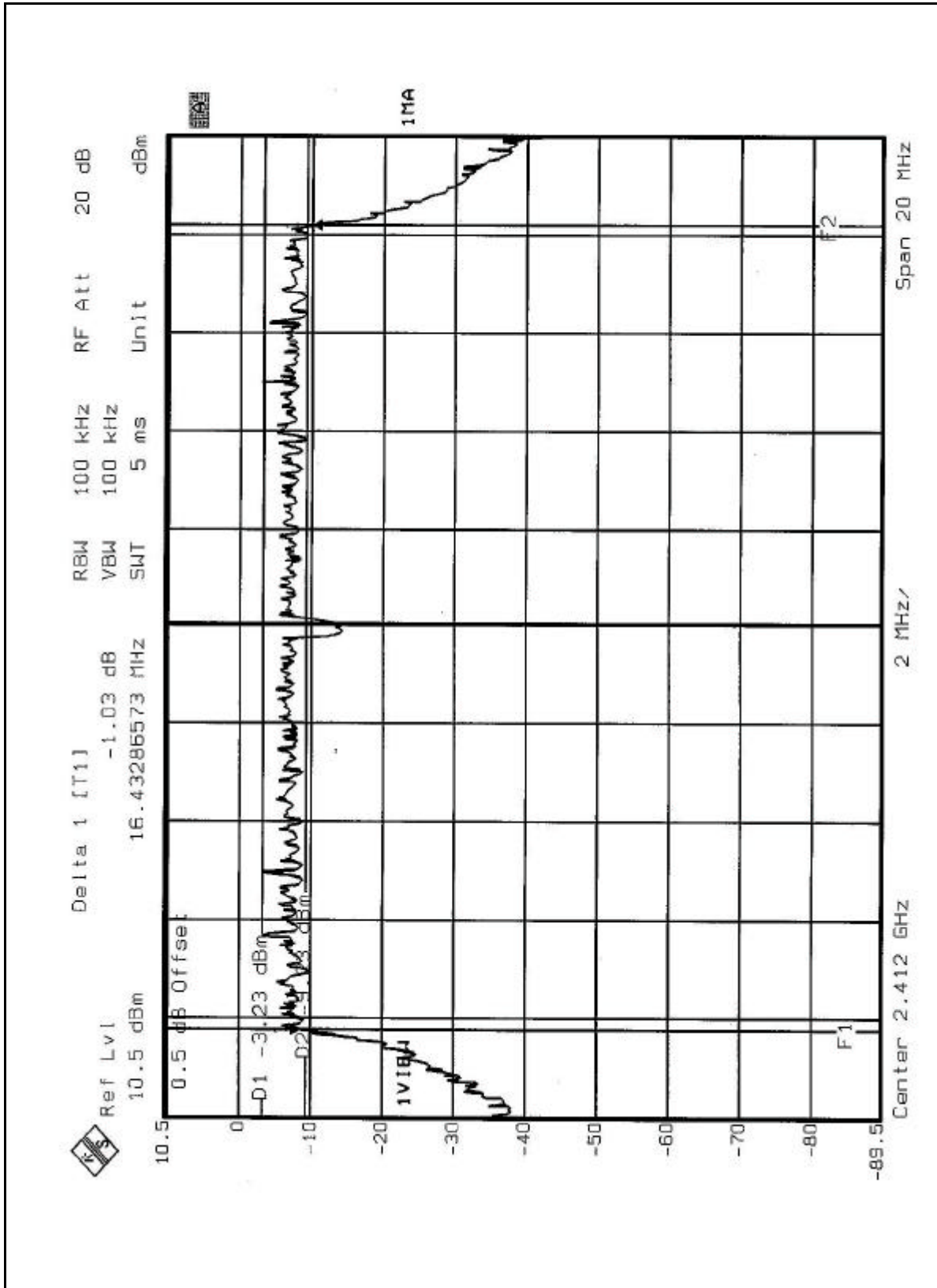





CH6

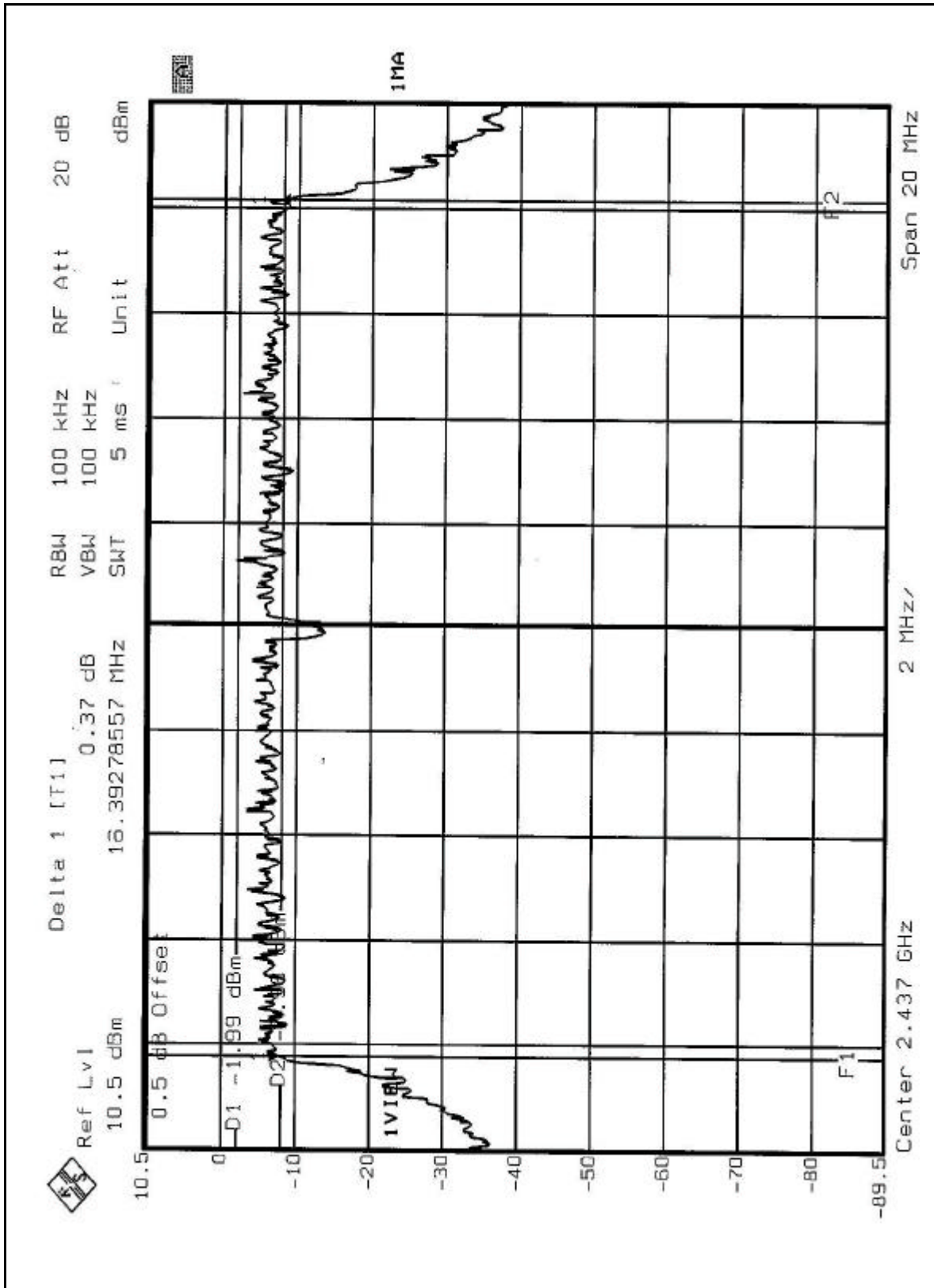



CH11

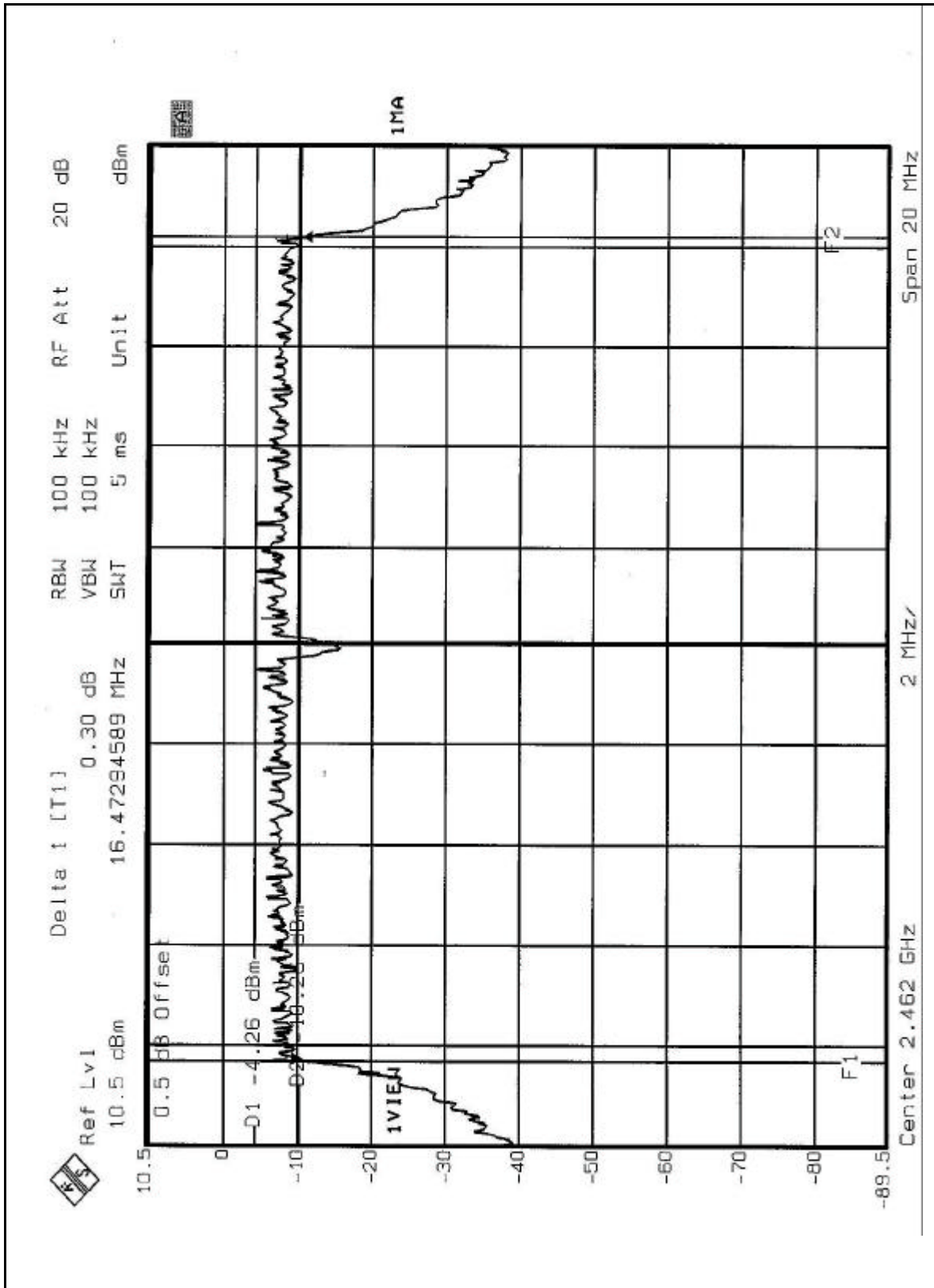



#### 4.4 MAXIMUM PEAK OUTPUT POWER

##### 4.4.1 LIMITS OF MAXIMUM PEAK OUTPUT POWER MEASUREMENT

The Maximum Peak Output Power Measurement is 30dBm.

##### 4.4.2 TEST INSTRUMENTS

Description & Manufacturer	Model No.	Serial No.	Calibrated Until
R&S SPECTRUM ANALYZER	FSEK30	100049	Aug. 12, 2005
AGILENT SIGNAL GENERATOR	E8257C	MY43320668	Dec. 31, 2004
TEKTRONIX OSCILLOSCOPE	TDS 220	C019167	Feb. 01, 2005
NARDA DETECTOR	4503A	FSCM99899	NA

**NOTE:**

The calibration interval of the above test instruments is 12 months and the calibrations are traceable to NML/ROC and NIST/USA.



#### 4.4.3 TEST PROCEDURES

1. A detector was used on the output port of the EUT. An oscilloscope was used to read the response of the detector.
2. Replaced the EUT by the signal generator. The center frequency of the S.G. was adjusted to the center frequency of the measured channel.
3. Adjusted the power to have the same reading on oscilloscope. Record the power level.

#### 4.4.4 DEVIATION FROM TEST STANDARD

No deviation

#### 4.4.5 TEST SETUP

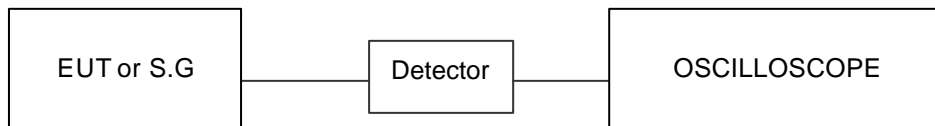

#### 4.4.6 EUT OPERATING CONDITIONS

Same as Item 4.3.6



4.4.7 TEST RESULTS (A)

<b>EUT</b>	ADSL Modem with High-Speed Mode Wireless-G Router	<b>MODEL</b>	F5D7633-4
<b>INPUT POWER (SYSTEM)</b>	120 Vac, 60 Hz	<b>ENVIRONMENTAL CONDITIONS</b>	24 deg. C, 64% RH, 991 hPa
<b>TESTED BY</b>	Leo Hung		

<b>CHANNEL</b>	<b>CHANNEL FREQUENCY (MHz)</b>	<b>PEAK POWER OUTPUT (mW)</b>	<b>PEAK POWER OUTPUT (dBm)</b>	<b>PEAK POWER LIMIT (dBm)</b>	<b>PASS/FAIL</b>
1	2412	32.36	15.10	30	PASS
6	2437	33.11	15.20	30	PASS
11	2462	31.62	15.00	30	PASS



## 4.4.8 TEST RESULTS (B)

<b>EUT</b>	ADSL Modem with High-Speed Mode Wireless-G Router	<b>MODEL</b>	F5D7633-4
<b>INPUT POWER (SYSTEM)</b>	120 Vac, 60 Hz	<b>ENVIRONMENTAL CONDITIONS</b>	24 deg. C, 64% RH, 991 hPa
<b>TESTED BY</b>	Leo Hung		

<b>CHANNEL</b>	<b>CHANNEL FREQUENCY (MHz)</b>	<b>PEAK POWER OUTPUT (mW)</b>	<b>PEAK POWER OUTPUT (dBm)</b>	<b>PEAK POWER LIMIT (dBm)</b>	<b>PASS/FAIL</b>
1	2412	31.62	15.00	30	PASS
6	2437	32.36	15.10	30	PASS
11	2462	33.11	15.20	30	PASS