

## FCC Test Report

**Report No.:** RFBGMK-WTW-P21030811

**FCC ID:** K7SAUF001V2

**Test Model:** AUF001 V2

**Received Date:** Mar. 23, 2021

**Test Date:** Apr. 19 to May 8, 2021

**Issued Date:** May 25, 2021

**Applicant:** Belkin International., Inc

**Address:** 12045 East Waterfront Drive, Playa Vista, CA 90094, USA

**Issued By:** Bureau Veritas Consumer Products Services (H.K.) Ltd., Taoyuan Branch  
Lin Kou Laboratories

**Lab Address:** No. 47-2, 14th Ling, Chia Pau Vil., Lin Kou Dist., New Taipei City, Taiwan

**FCC Registration /  
Designation Number:** 198487 / TW2021



This report is for your exclusive use. Any copying or replication of this report to or for any other person or entity, or use of our name or trademark, is permitted only with our prior written permission. This report sets forth our findings solely with respect to the test samples identified herein. The results set forth in this report are not indicative or representative of the quality or characteristics of the lot from which a test sample was taken or any similar or identical product unless specifically and expressly noted. Our report includes all of the tests requested by you and the results thereof based upon the information that you provided to us. You have 60 days from date of issuance of this report to notify us of any material error or omission caused by our negligence, provided, however, that such notice shall be in writing and shall specifically address the issue you wish to raise. A failure to raise such issue within the prescribed time shall constitute your unqualified acceptance of the completeness of this report, the tests conducted and the correctness of the report contents. Unless specific mention, the uncertainty of measurement has been explicitly taken into account to declare the compliance or non-compliance to the specification.

## Table of Contents

<b>Report Issue History Record .....</b>	<b>3</b>
<b>Release Control Record .....</b>	<b>3</b>
<b>1 Certificate of Conformity .....</b>	<b>4</b>
<b>2 Summary of Test Results .....</b>	<b>5</b>
2.1 Measurement Uncertainty .....	5
2.2 Modification Record .....	5
<b>3 General Information .....</b>	<b>6</b>
3.1 General Description of EUT .....	6
3.2 Description of Test Modes .....	6
3.2.1 Test Mode Applicability and Tested Channel Detail .....	7
3.3 Description of Support Units .....	8
3.3.1 Configuration of System under Test .....	8
3.4 General Description of Applied Standards .....	8
<b>4 Test Types and Results .....</b>	<b>9</b>
4.1 Radiated Emission and Bandedge Measurement .....	9
4.1.1 Limits of Radiated Emission and Bandedge Measurement .....	9
4.1.2 Test Instruments .....	10
4.1.3 Test Procedures .....	11
4.1.4 Deviation from Test Standard .....	11
4.1.5 Test Set Up .....	12
4.1.6 EUT Operating Conditions .....	12
4.1.7 Test Results .....	13
4.2 Conducted Emission Measurement .....	23
4.2.1 Limits of Conducted Emission Measurement .....	23
4.2.2 Test Instruments .....	23
4.2.3 Test Procedures .....	24
4.2.4 Deviation from Test Standard .....	24
4.2.5 Test Setup .....	24
4.2.6 EUT Operating Conditions .....	24
4.2.7 Test Results .....	25
<b>5 Pictures of Test Arrangements .....</b>	<b>29</b>
<b>Appendix – Information of the Testing Laboratories .....</b>	<b>30</b>

### Report Issue History Record

Issue No.	Description	Date Issued
RFBGMK-WTW-P21030811	Original release.	May 25, 2021

### Release Control Record

Issue No.	Description	Date Issued
RFBGMK-WTW-P21030811	Original release.	May 25, 2021

## 1 Certificate of Conformity

**Product:** SOUNDFORM™ Charge Bluetooth Speaker + Wireless Charger

**Brand:** belkin

**Test Model:** AUF001 V2

**Sample Status:** Engineering sample

**Applicant:** Belkin International., Inc

**Test Date:** Apr. 19 to May 8, 2021

**Standards:** 47 CFR FCC Part 15, Subpart C (Section 15.209)  
ANSI C63.10:2013

The above equipment has been tested by **Bureau Veritas Consumer Products Services (H.K.) Ltd., Taoyuan Branch**, and found compliance with the requirement of the above standards. The test record, data evaluation & Equipment Under Test (EUT) configurations represented herein are true and accurate accounts of the measurements of the sample's RF characteristics under the conditions specified in this report.

**Prepared by :**

*Annie Chang*

**Date:**

May 25, 2021

Annie Chang / Senior Specialist

**Approved by :**

*Rex Lai*

**Date:**

May 25, 2021

Rex Lai / Associate Technical Manager

## 2 Summary of Test Results

47 CFR FCC Part 15, Subpart C (Section 15.209)			
FCC Clause	Test Item	Result	Remarks
15.207	AC Power Conducted Emission	Pass	Meet the requirement of limit. Minimum passing margin is -13.17dB at 0.39943MHz
15.209	Radiated Emission Test	Pass	Meet the requirement of limit. Minimum passing margin is -2.52dB at 308.2780MHz

Note: Determining compliance based on the results of the compliance measurement, not taking into account measurement instrumentation uncertainty.

### 2.1 Measurement Uncertainty

Where relevant, the following measurement uncertainty levels have been estimated for tests performed on the EUT as specified in CISPR 16-4-2:

Measurement	Frequency	Expanded Uncertainty (k=2) ( $\pm$ )
Conducted Emissions at mains ports	150kHz ~ 30MHz	3.00 dB
Radiated Emissions up to 1 GHz	9kHz ~ 30MHz	2.61 dB
	30MHz ~ 1000MHz	5.43 dB

### 2.2 Modification Record

There were no modifications required for compliance.

### 3 General Information

#### 3.1 General Description of EUT

Product	SOUNDFORM™ Charge Bluetooth Speaker + Wireless Charger
Brand	belkin
Test Model	AUF001 V2
Sample Status	Engineering sample
Power Supply Rating	I/P rating: 12Vdc, 1.5A O/P rating: 10W
Modulation Type	FSK
Operating Frequency	127.8 kHz
Antenna Type	Coil antenna
Field Strength	9.76dBuV/m (@300m) (AV)
Dimensions	18.76cm <sup>2</sup> (Length = 47.5mm, Width = 39.5mm)
Accessory Device	Wall charger
Data Cable Supplied	N/A
Maximum Power Output from the Charging Coil	10W

Note:

1. The EUT is a SOUNDFORM™ Charge Bluetooth Speaker + Wireless Charger with Qi charging function.
2. The EUT uses following Wall charger.

Wall charger	1	2
Brand	belkin	belkin
Model	DSA-18PFR-12 FEU	DSA-18PFR-12 FUS
Plug Type	EU	US
Input Power	100-240Vac, 50/60Hz, 0.6A	100-240Vac, 50/60Hz, 0.6A
Output Power	+12.0Vdc, 1.5A, 18W	+12.0Vdc, 1.5A, 18W
Power Line	AC 2 Pin, Non-shielded DC (1.5m) attached on Wall charger	AC 2 Pin, Non-shielded DC (1.5m) attached on Wall charger

The two wall chargers are identical with each other except for their plug type difference.

During the test, **Wall charger 2** was selected as the representative one for the test.

3. The emission of the simultaneous operation (BT and Qi) has been evaluated and no non-compliance was found.
4. The above Antenna information is declared by manufacturer and for more detailed features description, please refer to the manufacturer's specifications, the laboratory shall not be held responsible.
5. The above EUT information is declared by manufacturer and for more detailed features description, please refer to the manufacturer's specifications or user's manual.

#### 3.2 Description of Test Modes

The following test frequency is provided to this EUT:

Operating Frequency (kHz)	Test Mode
127.8	Charging Mode with max Load
127.8	Standby Mode

### 3.2.1 Test Mode Applicability and Tested Channel Detail

EUT Configure Mode	Applicable To		Description
	RE<1G	PLC	
A	√	√	Charging Mode with max Load
B	√	√	Standby Mode

Where **RE<1G**: Radiated Emission below 1GHz **PLC**: Power Line Conducted Emission

#### Radiated Emission Test (Below 1GHz):

- Pre-Scan has been conducted to determine the worst-case mode from all possible combinations between available modulations, data rates and antenna ports (if EUT with antenna diversity architecture).
- Following channel(s) was (were) selected for the final test as listed below.

EUT Configure Mode	Operating Frequency (kHz)	Tested Frequency (kHz)
A	127.8	127.8
B	127.8	127.8

#### Power Line Conducted Emission Test:

- Pre-Scan has been conducted to determine the worst-case mode from all possible combinations between available modulations, data rates and antenna ports (if EUT with antenna diversity architecture).
- Following channel(s) was (were) selected for the final test as listed below.

EUT Configure Mode	Operating Frequency (kHz)	Tested Frequency (kHz)
A	127.8	127.8
B	127.8	127.8

#### Test Condition:

Applicable To	Environmental Conditions	Input Power	Tested by
<b>RE&lt;1G</b>	21 deg. C, 63% RH	120Vac, 60Hz	Jed Wu
<b>PLC</b>	25 deg. C, 75% RH	120Vac, 60Hz	Jed Wu

### 3.3 Description of Support Units

The EUT has been tested as an independent unit together with other necessary accessories or support units. The following support units or accessories were used to form a representative test configuration during the tests.

ID	Product	Brand	Model No.	Serial No.	FCC ID	Remarks
A.	Mechanical tool	N/A	N/A	N/A	N/A	Supplied by client
B.	Load	N/A	N/A	N/A	N/A	Supplied by client (10W max load)

ID	Cable Descriptions	Qty.	Length (m)	Shielding (Yes/No)	Cores (Qty.)	Remarks
1.	DC cable	1	0.1	N	0	Supplied by client
2.	DC cable	1	1.5	N	0	Supplied by client

Note: The core(s) is(are) originally attached to the cable(s).

#### 3.3.1 Configuration of System under Test

Charging Mode:

Test Mode A

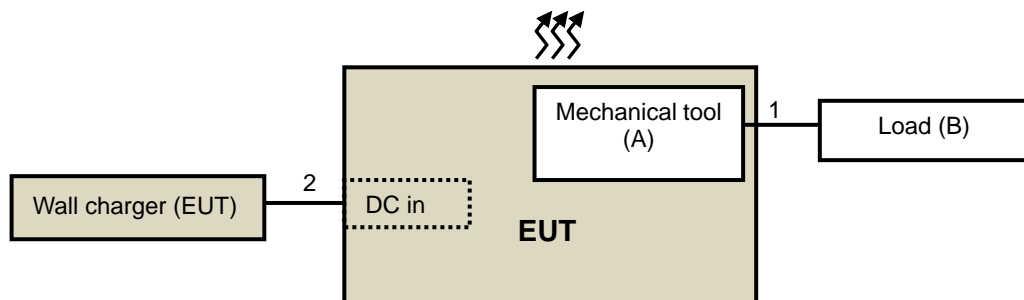

Standby Mode:

Test Mode B

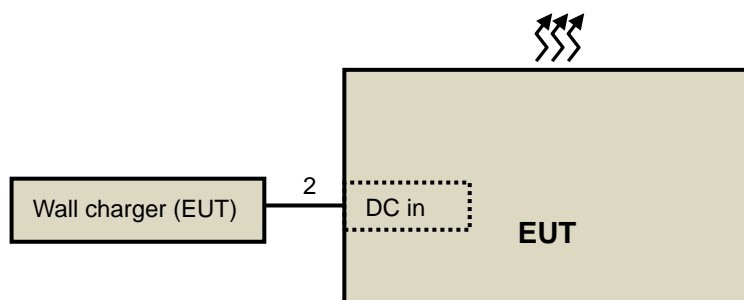

### 3.4 General Description of Applied Standards

The EUT is a RF Product. According to the specifications of the manufacturer, it must comply with the requirements of the following standards:

**47 CFR FCC Part 15, Subpart C (Section 15.209)**

ANSI C63.10-2013

All test items have been performed and recorded as per the above standards.



## 4 Test Types and Results

### 4.1 Radiated Emission and Bandedge Measurement

#### 4.1.1 Limits of Radiated Emission and Bandedge Measurement

##### For Frequency Below 30MHz

Frequency (MHz)	Field Strength (dBuV/m)		Measurement Distance (meters)
	uV/m	dBuV/m	
0.009 – 0.490	2400 / F (kHz)	48.52-13.80	300
0.490 – 1.705	24000 / F (kHz)	33.80-22.97	30
1.705 – 30.0	30	29.54	30

##### For Frequency Between 30-1000MHz

Frequency (MHz)	Field Strength (dBuV/m)		Measurement Distance (meters)
	uV/m	dBuV/m	
30-88	100	40.0	3
88-216	150	43.5	3
216-960	200	46.0	3
Above 960	500	54.0	3

#### 4.1.2 Test Instruments

DESCRIPTION & MANUFACTURER	MODEL NO.	SERIAL NO.	CALIBRATED DATE	CALIBRATED UNTIL
HP Preamplifier	8447D	2432A03504	Feb. 18, 2021	Feb. 17, 2022
MITEQ Preamplifier	AMF-6F-260400-33-8P	892164	Feb. 18, 2021	Feb. 17, 2022
Agilent TEST RECEIVER	N9038A	MY51210129	Mar. 12, 2021	Mar. 11, 2022
Schwarzbeck Antenna	VULB 9168	139	Nov. 6, 2020	Nov. 5, 2021
Schwarzbeck Antenna	VHBA 9123	480	Jun. 3, 2019	Jun. 2, 2021
ADT. Turn Table	TT100	0306	NA	NA
ADT. Tower	AT100	0306	NA	NA
Software	Radiated_V7.6.15.9.5	NA	NA	NA
SUHNER RF cable With 4dB PAD	SF102	Cable-CH6-01	Jul. 9, 2020	Jul. 8, 2021
E MEC RF cable With 3/4dB PAD	EM102-KMKM	01	Aug. 21, 2020	Aug. 20, 2021
KEYSIGHT Spectrum Analyzer	N9030A	MY54490260	Jul. 22, 2020	Jul. 21, 2021
Loop Antenna EMCI	LPA600	270	Aug. 23, 2019	Aug. 22, 2021
ROHDE & SCHWARZ Spectrum Analyzer	FSV40	101042	Sep. 8, 2020	Sep. 7, 2021

- NOTE:** 1. The calibration interval of the above test instruments is 12/24 months. And the calibrations are traceable to NML/ROC and NIST/USA.  
 2. The test was performed in Chamber No. 6.

### 4.1.3 Test Procedures

#### For Radiated emission below 30MHz

- a. The EUT was placed on the top of a rotating table 0.8 meters above the ground at a 3 meter chamber room. The table was rotated 360 degrees to determine the position of the highest radiation.
- b. The EUT was set 3 meters away from the interference-receiving antenna, which was mounted on the top of a variable-height antenna tower.
- c. Parallel, perpendicular, and ground-parallel orientations of the antenna are set to make the measurement.
- d. For each suspected emission, the EUT was arranged to its worst case and the rotatable table was turned from 0 degrees to 360 degrees to find the maximum reading.
- e. The test-receiver system was set to Quasi-Peak Detect Function and Specified Bandwidth with Maximum Hold Mode, except for the frequency band (9kHz-90kHz, 110kHz-490kHz) set to average detect function and peak detect function.

Note:

1. The resolution bandwidth and video bandwidth of test receiver/spectrum analyzer is 200Hz at frequency range 9kHz to 150kHz.
2. The resolution bandwidth and video bandwidth of test receiver/spectrum analyzer is 9kHz at frequency range 150kHz to 30MHz.

#### For Radiated emission above 30MHz

- a. The EUT was placed on the top of a rotating table 0.8 meters (for below 1GHz) above the ground at 3 meter chamber room for test. The table was rotated 360 degrees to determine the position of the highest radiation.
- b. The EUT was set 3 meters away from the interference-receiving antenna, which was mounted on the top of a variable-height antenna tower.
- c. The height of antenna is varied from one meter to four meters above the ground to determine the maximum value of the field strength. Both horizontal and vertical polarizations of the antenna are set to make the measurement.
- d. For each suspected emission, the EUT was arranged to its worst case and then the antenna was tuned to heights from 1 meter to 4 meters and the rotatable table was turned from 0 degrees to 360 degrees to find the maximum reading.
- e. The test-receiver system was set to quasi-peak detect function and specified bandwidth with maximum hold mode when the test frequency is below 1 GHz.

Note:

1. The resolution bandwidth and video bandwidth of test receiver/spectrum analyzer is 120kHz for Quasi-peak detection (QP) at frequency below 1GHz.
2. All modes of operation were investigated and the worst-case emissions are reported.

### 4.1.4 Deviation from Test Standard

No deviation.

#### 4.1.5 Test Set Up

##### For Radiated emission below 30MHz

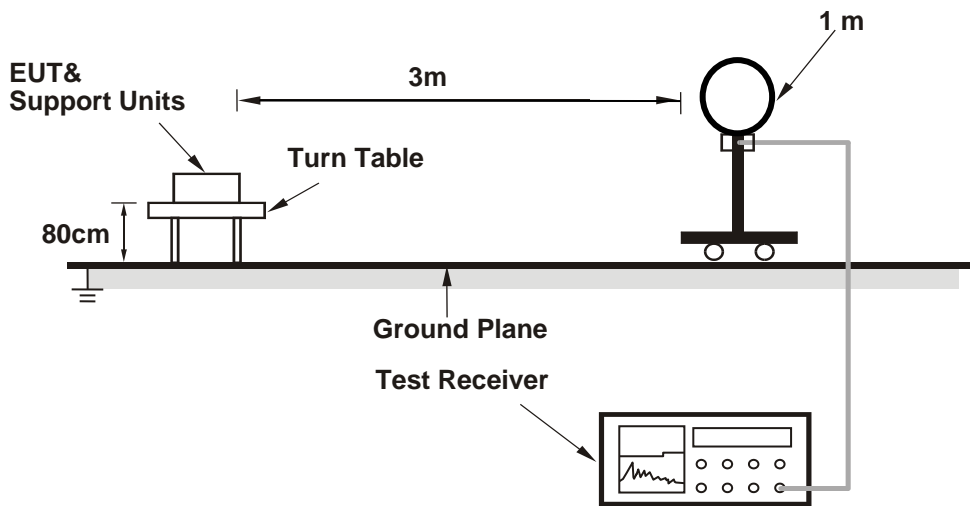

##### For Radiated emission 30MHz to 1GHz

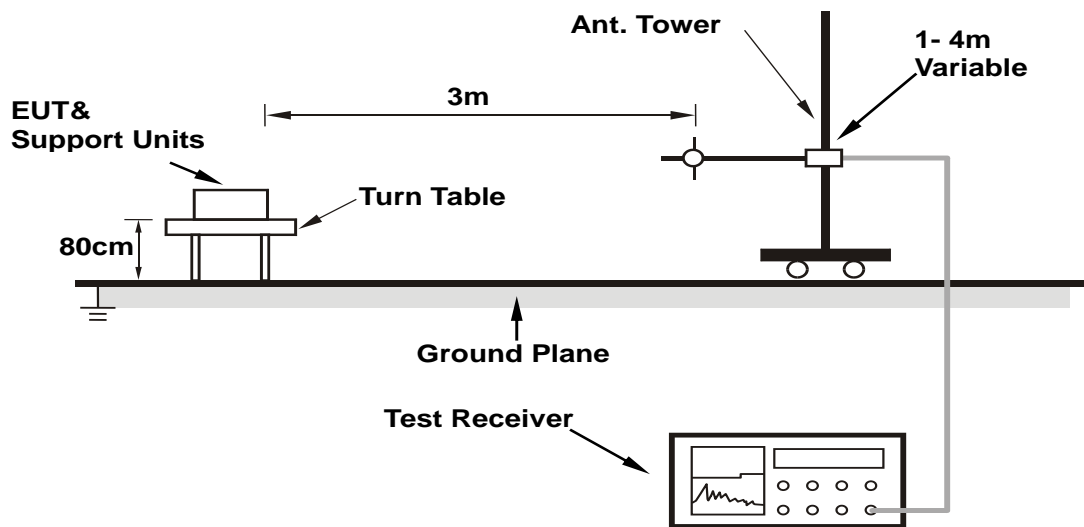

For the actual test configuration, please refer to the attached file (Test Setup Photo).

#### 4.1.6 EUT Operating Conditions

Set the EUT under transmission condition continuously at specific channel frequency.

#### 4.1.7 Test Results

Below 30MHz Data:

Charging Mode

Test Frequency	127.8kHz	Detector Function	Peak (PK)
Frequency Range	9kHz ~ 30MHz		Average (AV)
Test Mode	A		

Antenna Polarity : Parallel								
No	Frequency (MHz)	Emission Level (dBuV/m)	Limit (dBuV/m)	Margin (dB)	Antenna Height (m)	Table Angle (Degree)	Raw Value (dBuV)	Correction Factor (dB/m)
1	*0.1278	10.03 PK	45.47	-35.44	1.00	196	70.71	-60.68
2	*0.1278	9.76 AV	25.47	-15.71	1.00	196	70.44	-60.68
3	0.2556	-26.53 PK	39.45	-65.98	1.00	6	39.31	-65.84
4	0.2556	-26.86 AV	19.45	-46.31	1.00	6	38.98	-65.84
5	0.3834	-14.32 PK	35.93	-50.25	1.00	0	54.78	-69.10
6	0.3834	-14.71 AV	15.93	-30.64	1.00	0	54.39	-69.10

**Remarks:**

1. Emission Level(dBuV/m) = Raw Value(dBuV) + Correction Factor(dB/m)
2. Correction Factor(dB/m) = Antenna Factor(dB/m) + Cable Factor(dB) – Pre-Amplifier Factor(dB) + Distance Factor(dB)
3. Margin value = Emission Level – Limit value
4. The other emission levels were very low against the limit.
5. " \* ": Fundamental frequency.
6. The test distance for below 0.49MHz is 3m, extrapolate the measured field strength to a distance of 300 meters.  
Distance factor@3m =  $40 \cdot \log(3/300) = -80\text{dB}$

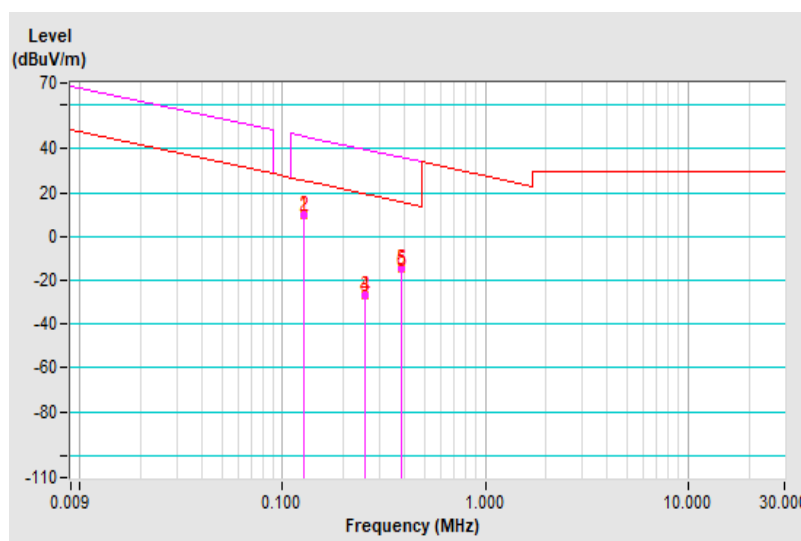

Test Frequency	127.8kHz	Detector Function	Peak (PK) Average (AV)
Frequency Range	9kHz ~ 30MHz		
Test Mode	A		

Antenna Polarity : Perpendicular								
No	Frequency (MHz)	Emission Level (dBuV/m)	Limit (dBuV/m)	Margin (dB)	Antenna Height (m)	Table Angle (Degree)	Raw Value (dBuV)	Correction Factor (dB/m)
1	*0.1278	2.22 PK	45.47	-43.25	1.00	263	62.90	-60.68
2	*0.1278	1.93 AV	25.47	-23.54	1.00	263	62.61	-60.68
3	0.2556	-42.93 PK	39.45	-82.38	1.00	27	22.91	-65.84
4	0.2556	-43.12 AV	19.45	-62.57	1.00	27	22.72	-65.84
5	0.3834	-20.66 PK	35.93	-56.59	1.00	51	48.44	-69.10
6	0.3834	-21.03 AV	15.93	-36.96	1.00	51	48.07	-69.10

**Remarks:**

- Emission Level(dBuV/m) = Raw Value(dBuV) + Correction Factor(dB/m)
- Correction Factor(dB/m) = Antenna Factor(dB/m) + Cable Factor(dB) – Pre-Amplifier Factor(dB) + Distance Factor(dB)
- Margin value = Emission Level – Limit value
- The other emission levels were very low against the limit.
- " \* ": Fundamental frequency.
- The test distance for below 0.49MHz is 3m, extrapolate the measured field strength to a distance of 300 meters.  
Distance factor@3m =  $40 \cdot \log(3/300) = -80\text{dB}$

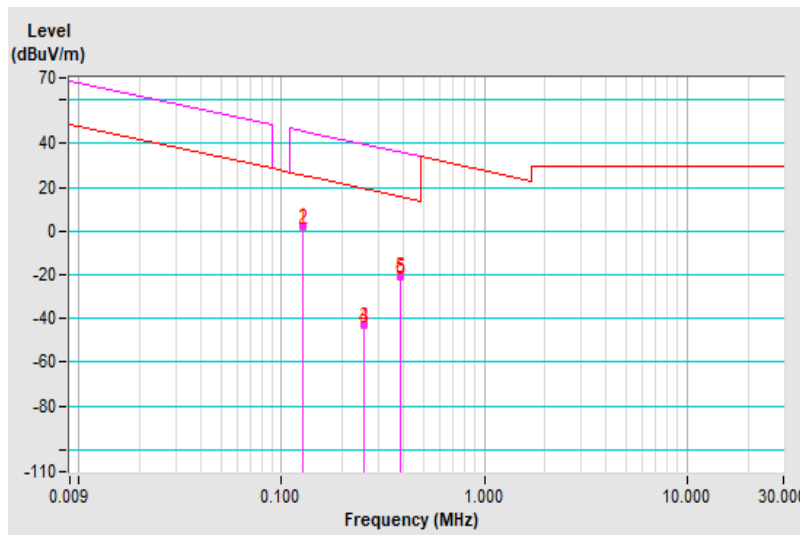

Test Frequency	127.8kHz	Detector Function	Peak (PK)
Frequency Range	9kHz ~ 30MHz		Average (AV)
Test Mode	A		

Antenna Polarity : Ground-parallel								
No	Frequency (MHz)	Emission Level (dBuV/m)	Limit (dBuV/m)	Margin (dB)	Antenna Height (m)	Table Angle (Degree)	Raw Value (dBuV)	Correction Factor (dB/m)
1	*0.1278	2.12 PK	45.47	-43.35	1.00	324	62.80	-60.68
2	*0.1278	1.88 AV	25.47	-23.59	1.00	324	62.56	-60.68
3	0.2556	-26.83 PK	39.45	-66.28	1.00	245	39.01	-65.84
4	0.2556	-27.19 AV	19.45	-46.64	1.00	245	38.65	-65.84
5	0.3834	-20.15 PK	35.93	-56.08	1.00	168	48.95	-69.10
6	0.3834	-20.57 AV	15.93	-36.50	1.00	168	48.53	-69.10

**Remarks:**

- Emission Level(dBuV/m) = Raw Value(dBuV) + Correction Factor(dB/m)
- Correction Factor(dB/m) = Antenna Factor(dB/m) + Cable Factor(dB) – Pre-Amplifier Factor(dB) + Distance Factor(dB)
- Margin value = Emission Level – Limit value
- The other emission levels were very low against the limit.
- " \* ": Fundamental frequency.
- The test distance for below 0.49MHz is 3m, extrapolate the measured field strength to a distance of 300 meters.  
Distance factor@3m =  $40 \cdot \log(3/300) = -80\text{dB}$

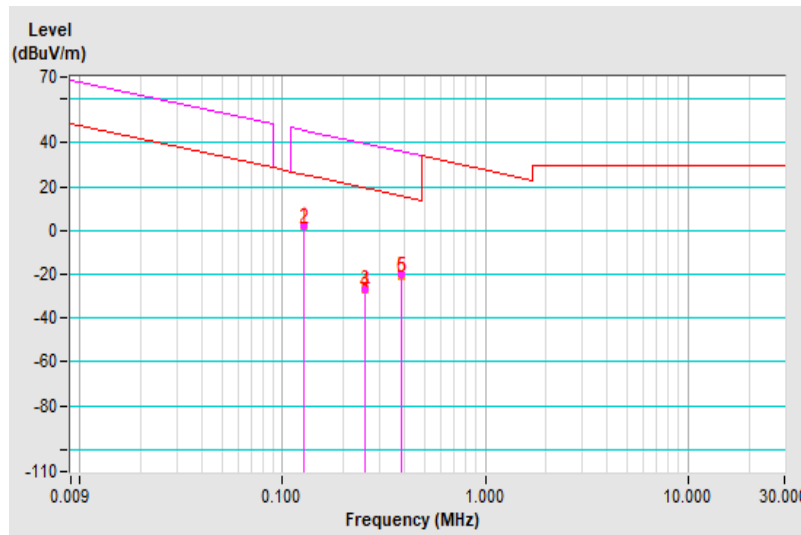

Standby Mode

Test Frequency	127.8kHz	Detector Function	Peak (PK)
Frequency Range	9kHz ~ 30MHz		Average (AV)
Test Mode	B		

Antenna Polarity : Parallel								
No	Frequency (MHz)	Emission Level (dBuV/m)	Limit (dBuV/m)	Margin (dB)	Antenna Height (m)	Table Angle (Degree)	Raw Value (dBuV)	Correction Factor (dB/m)
1	*0.1278	6.09 PK	45.47	-39.38	1.00	248	66.77	-60.68
2	*0.1278	5.79 AV	25.47	-19.68	1.00	248	66.47	-60.68
3	0.2555	-27.15 PK	39.46	-66.61	1.00	206	38.69	-65.84
4	0.2555	-27.63 AV	19.45	-47.08	1.00	206	38.21	-65.84
5	0.3833	-17.98 PK	35.93	-53.91	1.00	124	51.12	-69.10
6	0.3833	-18.32 AV	15.93	-34.25	1.00	124	50.78	-69.10

Remarks:

1. Emission Level(dBuV/m) = Raw Value(dBuV) + Correction Factor(dB/m)
2. Correction Factor(dB/m) = Antenna Factor(dB/m) + Cable Factor(dB) – Pre-Amplifier Factor(dB) + Distance Factor(dB)
3. Margin value = Emission Level – Limit value
4. The other emission levels were very low against the limit.
5. " \* ": Fundamental frequency.
6. The test distance for below 0.49MHz is 3m, extrapolate the measured field strength to a distance of 300 meters.  
Distance factor@3m =  $40 \cdot \log(3/300) = -80\text{dB}$

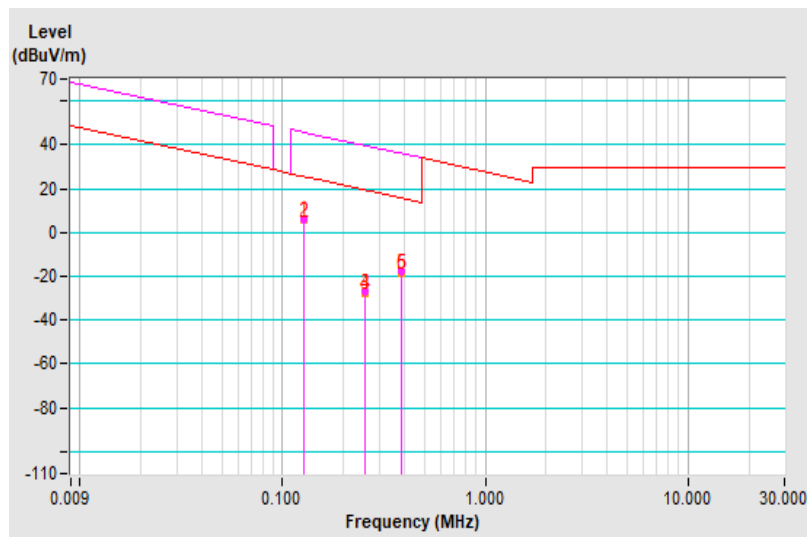



Test Frequency	127.8kHz	Detector Function	Peak (PK) Average (AV)
Frequency Range	9kHz ~ 30MHz		
Test Mode	B		

Antenna Polarity : Perpendicular								
No	Frequency (MHz)	Emission Level (dBuV/m)	Limit (dBuV/m)	Margin (dB)	Antenna Height (m)	Table Angle (Degree)	Raw Value (dBuV)	Correction Factor (dB/m)
1	*0.1278	2.05 PK	45.47	-43.42	1.00	247	62.73	-60.68
2	*0.1278	1.76 AV	25.47	-23.71	1.00	247	62.44	-60.68
3	0.2555	-25.42 PK	19.45	-44.87	1.00	238	40.42	-65.84
4	0.2555	-25.01 AV	39.45	-64.46	1.00	238	40.83	-65.84
5	0.3833	-23.14 PK	35.93	-59.07	1.00	289	45.96	-69.10
6	0.3833	-23.63 AV	15.93	-39.56	1.00	289	45.47	-69.10

**Remarks:**

1. Emission Level(dBuV/m) = Raw Value(dBuV) + Correction Factor(dB/m)
2. Correction Factor(dB/m) = Antenna Factor(dB/m) + Cable Factor(dB) – Pre-Amplifier Factor(dB) + Distance Factor(dB)
3. Margin value = Emission Level – Limit value
4. The other emission levels were very low against the limit.
5. " \* ": Fundamental frequency.
6. The test distance for below 0.49MHz is 3m, extrapolate the measured field strength to a distance of 300 meters.  
Distance factor@3m =  $40 \cdot \log(3/300) = -80\text{dB}$

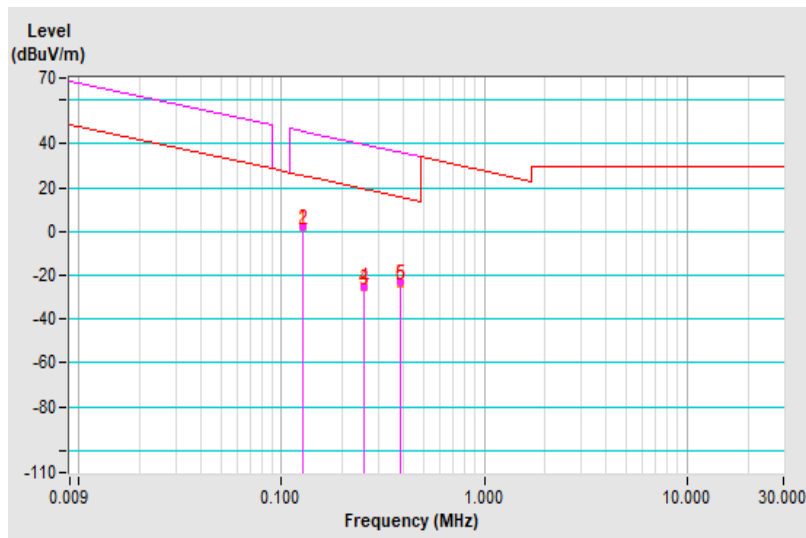

Test Frequency	127.8kHz	Detector Function	Peak (PK) Average (AV)
Frequency Range	9kHz ~ 30MHz		
Test Mode	B		

Antenna Polarity : Ground-parallel								
No	Frequency (MHz)	Emission Level (dBuV/m)	Limit (dBuV/m)	Margin (dB)	Antenna Height (m)	Table Angle (Degree)	Raw Value (dBuV)	Correction Factor (dB/m)
1	*0.1278	2.09 PK	45.47	-43.38	1.00	316	62.77	-60.68
2	*0.1278	1.86 AV	25.47	-23.61	1.00	316	62.54	-60.68
3	0.2555	-43.93 PK	39.45	-83.38	1.00	184	21.91	-65.84
4	0.2555	-43.95 AV	19.45	-63.40	1.00	184	21.89	-65.84
5	0.3833	-25.17 PK	35.93	-61.10	1.00	265	43.93	-69.10
6	0.3833	-24.85 AV	15.93	-40.78	1.00	265	44.25	-69.10

**Remarks:**

- Emission Level(dBuV/m) = Raw Value(dBuV) + Correction Factor(dB/m)
- Correction Factor(dB/m) = Antenna Factor(dB/m) + Cable Factor(dB) – Pre-Amplifier Factor(dB) + Distance Factor(dB)
- Margin value = Emission Level – Limit value
- The other emission levels were very low against the limit.
- " \* ": Fundamental frequency.
- The test distance for below 0.49MHz is 3m, extrapolate the measured field strength to a distance of 300 meters.  
Distance factor@3m =  $40 \cdot \log(3/300) = -80\text{dB}$

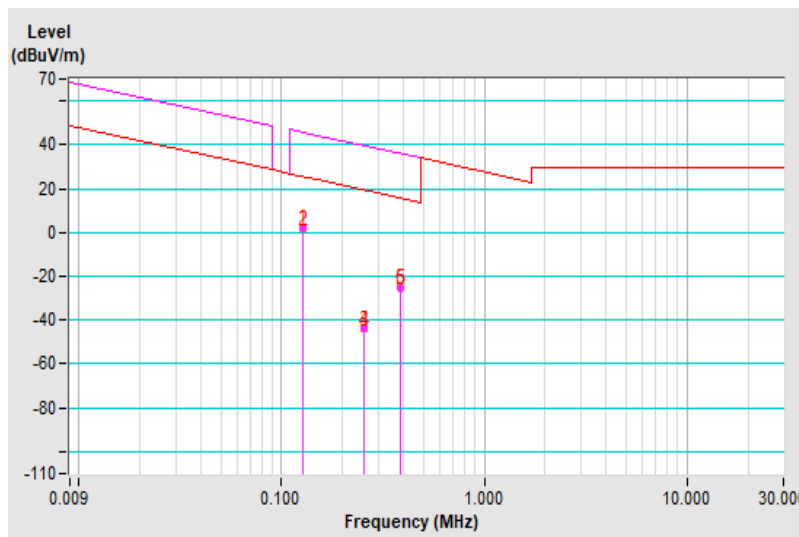

Above 30MHz Data:

Charging Mode

<b>Test Frequency</b>	127.8kHz	<b>Detector Function</b>	Quasi-Peak (QP)
<b>Frequency Range</b>	30MHz ~ 1GHz		
<b>Test Mode</b>	A		

**Antenna Polarity & Test Distance : Horizontal at 3 m**

No	Frequency (MHz)	Emission Level (dBuV/m)	Limit (dBuV/m)	Margin (dB)	Antenna Height (m)	Table Angle (Degree)	Raw Value (dBuV)	Correction Factor (dB/m)
1	69.4790	24.56 QP	40.00	-15.44	1.48 H	107	33.50	-8.94
2	146.2060	29.46 QP	43.50	-14.04	1.63 H	83	36.07	-6.61
3	209.4985	33.51 QP	43.50	-9.99	2.46 H	336	42.25	-8.74
<b>4</b>	<b>308.2780</b>	<b>43.48 QP</b>	<b>46.00</b>	<b>-2.52</b>	<b>1.02 H</b>	<b>122</b>	<b>47.51</b>	<b>-4.03</b>
5	444.2385	32.42 QP	46.00	-13.58	2.79 H	137	33.26	-0.84
6	493.2720	31.04 QP	46.00	-14.96	1.00 H	16	31.02	0.02

**Remarks:**

1. Emission Level(dBuV/m) = Raw Value(dBuV) + Correction Factor(dB/m)
2. Correction Factor(dB/m) = Antenna Factor(dB/m) + Cable Factor(dB) – Pre-Amplifier Factor(dB)
3. Margin value = Emission Level – Limit value
4. The other emission levels were very low against the limit of frequency range 30MHz~1000MHz.

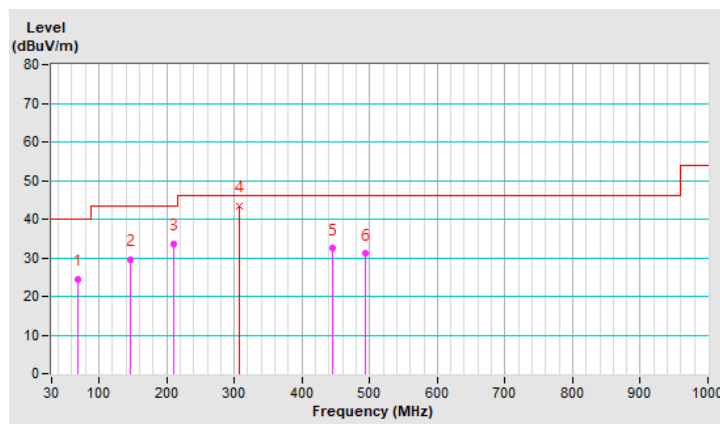

Test Frequency	127.8kHz	Detector Function	Quasi-Peak (QP)
Frequency Range	30MHz ~ 1GHz		
Test Mode	A		

Antenna Polarity & Test Distance : Vertical at 3 m								
No	Frequency (MHz)	Emission Level (dBuV/m)	Limit (dBuV/m)	Margin (dB)	Antenna Height (m)	Table Angle (Degree)	Raw Value (dBuV)	Correction Factor (dB/m)
1	41.6400	34.65 QP	40.00	-5.35	1.59 V	98	42.08	-7.43
2	63.7560	33.32 QP	40.00	-6.68	1.28 V	150	41.45	-8.13
3	150.5710	30.12 QP	43.50	-13.38	2.41 V	103	36.60	-6.48
4	208.3345	27.18 QP	43.50	-16.32	2.16 V	250	35.97	-8.79
5	308.1475	42.26 QP	46.00	-3.74	2.37 V	160	46.29	-4.03
6	476.8305	33.39 QP	46.00	-12.61	2.68 V	179	33.60	-0.21

**Remarks:**

1. Emission Level(dBuV/m) = Raw Value(dBuV) + Correction Factor(dB/m)
2. Correction Factor(dB/m) = Antenna Factor(dB/m) + Cable Factor(dB) – Pre-Amplifier Factor(dB)
3. Margin value = Emission Level – Limit value
4. The other emission levels were very low against the limit of frequency range 30MHz~1000MHz.

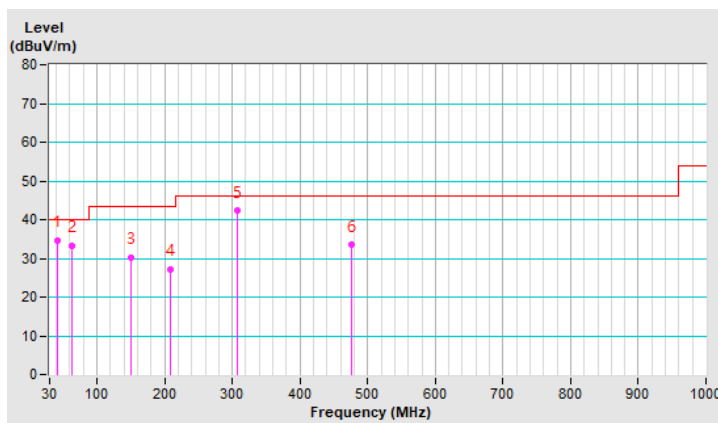

Standby Mode

Test Frequency	127.8kHz	Detector Function	Quasi-Peak (QP)
Frequency Range	30MHz ~ 1GHz		
Test Mode	B		

Antenna Polarity & Test Distance : Horizontal at 3 m								
No	Frequency (MHz)	Emission Level (dBuV/m)	Limit (dBuV/m)	Margin (dB)	Antenna Height (m)	Table Angle (Degree)	Raw Value (dBuV)	Correction Factor (dB/m)
1	52.8000	27.44 QP	40.00	-12.56	1.67 H	48	34.43	-6.99
2	65.2600	26.19 QP	40.00	-13.81	2.34 H	247	34.53	-8.34
3	160.3200	23.33 QP	43.50	-20.17	1.33 H	60	29.64	-6.31
4	275.2200	33.78 QP	46.00	-12.22	1.57 H	217	38.83	-5.05
5	309.5500	35.64 QP	46.00	-10.36	2.41 H	197	39.63	-3.99
6	380.6100	30.89 QP	46.00	-15.11	2.19 H	33	33.26	-2.37

Remarks:

1. Emission Level(dBuV/m) = Raw Value(dBuV) + Correction Factor(dB/m)
2. Correction Factor(dB/m) = Antenna Factor(dB/m) + Cable Factor(dB) – Pre-Amplifier Factor(dB)
3. Margin value = Emission Level – Limit value
4. The other emission levels were very low against the limit of frequency range 30MHz~1000MHz.

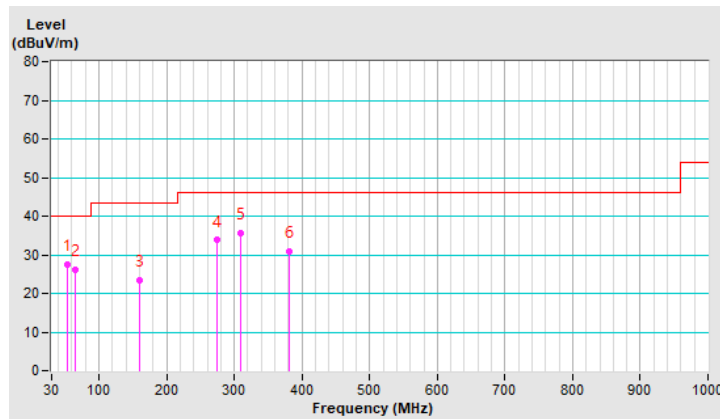

Test Frequency	127.8kHz	Detector Function	Quasi-Peak (QP)
Frequency Range	30MHz ~ 1GHz		
Test Mode	B		

Antenna Polarity & Test Distance : Vertical at 3 m								
No	Frequency (MHz)	Emission Level (dBuV/m)	Limit (dBuV/m)	Margin (dB)	Antenna Height (m)	Table Angle (Degree)	Raw Value (dBuV)	Correction Factor (dB/m)
1	49.4970	25.26 QP	40.00	-14.74	1.62 V	8	32.23	-6.97
2	64.3865	27.21 QP	40.00	-12.79	1.58 V	189	35.49	-8.28
3	156.1000	24.66 QP	43.50	-18.84	1.24 V	121	31.07	-6.41
4	271.5300	35.38 QP	46.00	-10.62	1.07 V	182	40.65	-5.27
5	309.2145	36.92 QP	46.00	-9.08	2.09 V	167	40.93	-4.01
6	389.5790	31.28 QP	46.00	-14.72	2.11 V	11	33.53	-2.25

**Remarks:**

1. Emission Level(dBuV/m) = Raw Value(dBuV) + Correction Factor(dB/m)
2. Correction Factor(dB/m) = Antenna Factor(dB/m) + Cable Factor(dB) – Pre-Amplifier Factor(dB)
3. Margin value = Emission Level – Limit value
4. The other emission levels were very low against the limit of frequency range 30MHz~1000MHz.

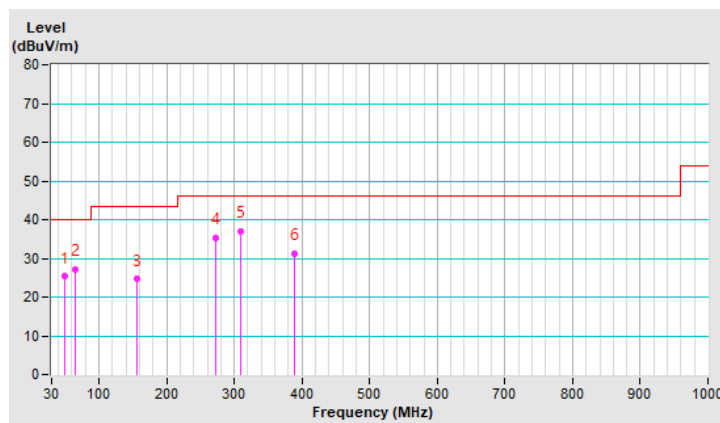

## 4.2 Conducted Emission Measurement

### 4.2.1 Limits of Conducted Emission Measurement

Frequency (MHz)	Conducted Limit (dBuV)	
	Quasi-peak	Average
0.15 - 0.5	66 - 56	56 - 46
0.50 - 5.0	56	46
5.0 - 30.0	60	50

Note: 1. The lower limit shall apply at the transition frequencies.

2. The limit decreases in line with the logarithm of the frequency in the range of 0.15 to 0.50MHz.

### 4.2.2 Test Instruments

Description & Manufacturer	Model No.	Serial No.	Cal. Date	Cal. Due
ROHDE & SCHWARZ TEST RECEIVER	ESR3	102412	Jan. 29, 2021	Jan. 28, 2022
SCHWARZBECK Artificial Mains Network (for EUT)	NSLK 8128	8128-244	Nov. 19, 2020	Nov. 18, 2021
LISN With Adapter (for EUT)	AD10	C05Ada-001	Nov. 19, 2020	Nov. 18, 2021
R&S Artificial Mains Network (for peripheral)	ESH3-Z5	100220	Dec. 1, 2020	Nov. 30, 2021
Software	Cond_V7.3.7.4	NA	NA	NA
RF cable (JYEBAO) With 10dB PAD	5D-FB	Cable-C05.01	Jan. 29, 2021	Jan. 28, 2022
LYNICS Terminator (For R&S LISN)	0900510	E1-01-305	Feb. 17, 2021	Feb. 16, 2022

Note: 1. The calibration interval of the above test instruments is 12 months and the calibrations are traceable to NML/ROC and NIST/USA.

2. The test was performed in Shielded Room No. 5. (Conduction 5)

3. The VCCI Site Registration No. C-11093.

#### 4.2.3 Test Procedures

- The EUT was placed 0.4 meters from the conducting wall of the shielded room with EUT being connected to the power mains through a line impedance stabilization network (LISN). Other support units were connected to the power mains through another LISN. The two LISNs provide 50 ohm/ 50uH of coupling impedance for the measuring instrument.
- Both lines of the power mains connected to the EUT were checked for maximum conducted interference.
- The frequency range from 150kHz to 30MHz was searched. Emission levels under (Limit - 20dB) were not recorded.

Note: The resolution bandwidth and video bandwidth of test receiver is 9kHz for quasi-peak detection (QP) and average detection (AV) at frequency 0.15MHz-30MHz.

#### 4.2.4 Deviation from Test Standard

No deviation.

#### 4.2.5 Test Setup

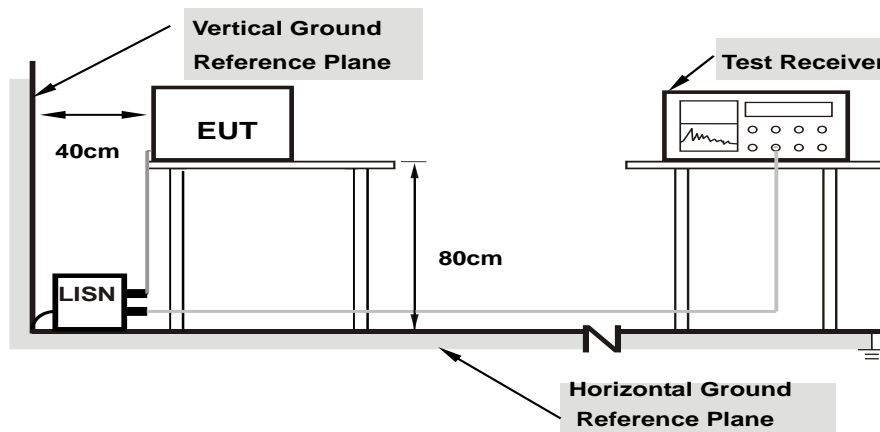

Note: Support units were connected to second LISN.

For the actual test configuration, please refer to the attached file (Test Setup Photo).

#### 4.2.6 EUT Operating Conditions

Same as item 4.1.6.



#### 4.2.7 Test Results

Frequency Range	150kHz ~ 30MHz	Detector Function & Resolution Bandwidth	Quasi-Peak (QP) / Average (AV), 9kHz
Test Mode	A		

Phase Of Power : Line (L)										
No	Frequency (MHz)	Correction Factor (dB)	Reading Value (dBuV)		Emission Level (dBuV)		Limit (dBuV)		Margin (dB)	
			Q.P.	AV.	Q.P.	AV.	Q.P.	AV.	Q.P.	AV.
1	0.18187	10.01	36.60	24.19	46.61	34.20	64.40	54.40	-17.79	-20.20
2	0.25017	10.01	35.93	22.98	45.94	32.99	61.75	51.75	-15.81	-18.76
3	0.57735	10.04	25.49	14.93	35.53	24.97	56.00	46.00	-20.47	-21.03
4	4.00498	10.29	22.52	16.38	32.81	26.67	56.00	46.00	-23.19	-19.33
5	9.45478	10.61	20.44	14.92	31.05	25.53	60.00	50.00	-28.95	-24.47
6	16.35986	11.00	25.16	19.97	36.16	30.97	60.00	50.00	-23.84	-19.03

**Remarks:**

1. Q.P. and AV. are abbreviations of quasi-peak and average individually.
2. The emission levels of other frequencies were very low against the limit.
3. Margin value = Emission level – Limit value
4. Correction factor = Insertion loss + Cable loss
5. Emission Level = Correction Factor + Reading Value

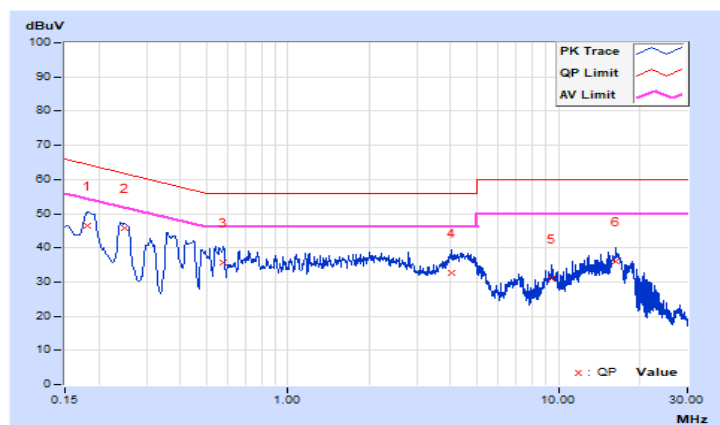

<b>Frequency Range</b>	150kHz ~ 30MHz	<b>Detector Function &amp; Resolution Bandwidth</b>	Quasi-Peak (QP) / Average (AV), 9kHz
<b>Test Mode</b>	A		

Phase Of Power : Neutral (N)										
No	Frequency (MHz)	Correction Factor (dB)	Reading Value (dBuV)		Emission Level (dBuV)		Limit (dBuV)		Margin (dB)	
			Q.P.	AV.	Q.P.	AV.	Q.P.	AV.	Q.P.	AV.
1	0.18542	9.94	33.90	29.19	43.84	39.13	64.24	54.24	-20.40	-15.11
2	0.23924	9.94	32.86	19.16	42.80	29.10	62.12	52.12	-19.32	-23.02
3	0.53900	9.97	26.05	14.30	36.02	24.27	56.00	46.00	-19.98	-21.73
4	2.80598	10.11	23.52	17.90	33.63	28.01	56.00	46.00	-22.37	-17.99
5	9.71175	10.54	21.14	16.13	31.68	26.67	60.00	50.00	-28.32	-23.33
6	13.54786	10.80	22.93	18.86	33.73	29.66	60.00	50.00	-26.27	-20.34

**Remarks:**

1. Q.P. and AV. are abbreviations of quasi-peak and average individually.
2. The emission levels of other frequencies were very low against the limit.
3. Margin value = Emission level – Limit value
4. Correction factor = Insertion loss + Cable loss
5. Emission Level = Correction Factor + Reading Value

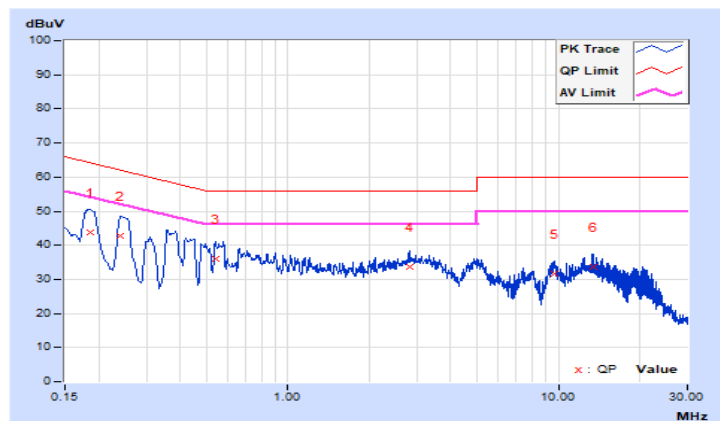

<b>Frequency Range</b>	150kHz ~ 30MHz	<b>Detector Function &amp; Resolution Bandwidth</b>	Quasi-Peak (QP) / Average (AV), 9kHz
<b>Test Mode</b>	B		

Phase Of Power : Line (L)										
No	Frequency (MHz)	Correction Factor (dB)	Reading Value (dBuV)		Emission Level (dBuV)		Limit (dBuV)		Margin (dB)	
			Q.P.	AV.	Q.P.	AV.	Q.P.	AV.	Q.P.	AV.
1	0.16265	10.01	34.42	31.23	44.43	41.24	65.33	55.33	-20.90	-14.09
2	0.40079	10.02	33.04	24.24	43.06	34.26	57.84	47.84	-14.78	-13.58
3	1.06593	10.10	18.34	14.15	28.44	24.25	56.00	46.00	-27.56	-21.75
4	2.80935	10.20	20.53	15.50	30.73	25.70	56.00	46.00	-25.27	-20.30
5	5.35809	10.37	13.73	8.48	24.10	18.85	60.00	50.00	-35.90	-31.15
6	9.59283	10.62	8.01	3.66	18.63	14.28	60.00	50.00	-41.37	-35.72

**Remarks:**

1. Q.P. and AV. are abbreviations of quasi-peak and average individually.
2. The emission levels of other frequencies were very low against the limit.
3. Margin value = Emission level – Limit value
4. Correction factor = Insertion loss + Cable loss
5. Emission Level = Correction Factor + Reading Value

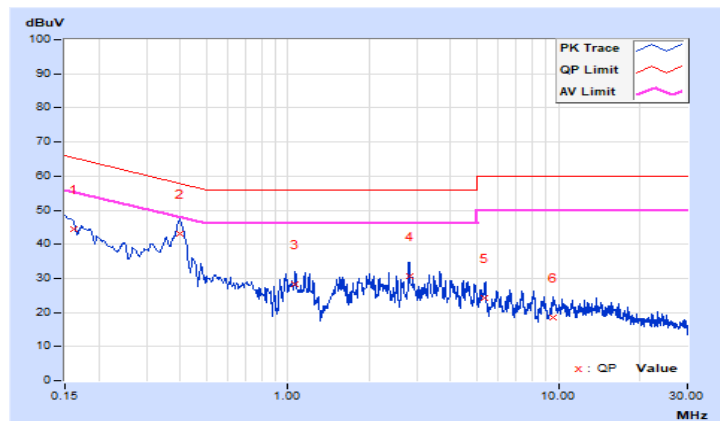

<b>Frequency Range</b>	150kHz ~ 30MHz	<b>Detector Function &amp; Resolution Bandwidth</b>	Quasi-Peak (QP) / Average (AV), 9kHz
<b>Test Mode</b>	B		

Phase Of Power : Neutral (N)										
No	Frequency (MHz)	Correction Factor (dB)	Reading Value (dBuV)		Emission Level (dBuV)		Limit (dBuV)		Margin (dB)	
			Q.P.	AV.	Q.P.	AV.	Q.P.	AV.	Q.P.	AV.
1	0.17496	9.93	32.64	29.78	42.57	39.71	64.72	54.72	-22.15	-15.01
<b>2</b>	<b>0.39943</b>	<b>9.96</b>	<b>33.36</b>	<b>24.74</b>	<b>43.32</b>	<b>34.70</b>	<b>57.87</b>	<b>47.87</b>	<b>-14.55</b>	<b>-13.17</b>
3	0.97876	10.01	18.73	14.69	28.74	24.70	56.00	46.00	-27.26	-21.30
4	2.80644	10.11	20.89	15.92	31.00	26.03	56.00	46.00	-25.00	-19.97
5	5.36327	10.27	12.20	7.13	22.47	17.40	60.00	50.00	-37.53	-32.60
6	7.32251	10.39	9.97	4.74	20.36	15.13	60.00	50.00	-39.64	-34.87

**Remarks:**

1. Q.P. and AV. are abbreviations of quasi-peak and average individually.
2. The emission levels of other frequencies were very low against the limit.
3. Margin value = Emission level – Limit value
4. Correction factor = Insertion loss + Cable loss
5. Emission Level = Correction Factor + Reading Value

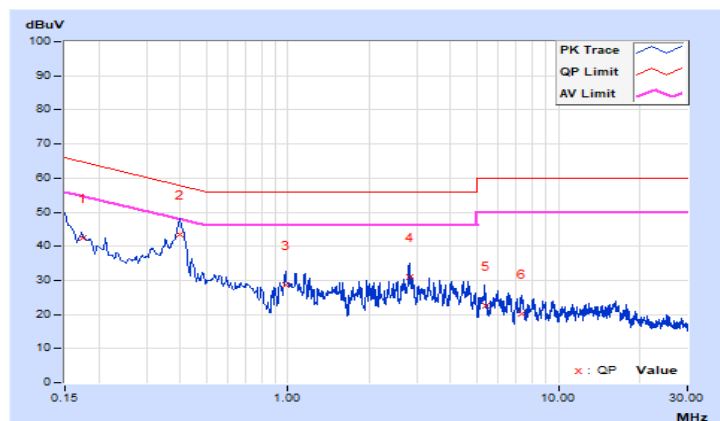

## 5 Pictures of Test Arrangements

Please refer to the attached file (Test Setup Photo).

## Appendix – Information of the Testing Laboratories

We, Bureau Veritas Consumer Products Services (H.K.) Ltd., Taoyuan Branch, were founded in 1988 to provide our best service in EMC, Radio, Telecom and Safety consultation. Our laboratories are FCC recognized accredited test firms and accredited and approved according to ISO/IEC 17025.

If you have any comments, please feel free to contact us at the following:

### Lin Kou EMC/RF Lab

Tel: 886-2-26052180

Fax: 886-2-26051924

### Hsin Chu EMC/RF/Telecom Lab

Tel: 886-3-6668565

Fax: 886-3-6668323

### Hwa Ya EMC/RF/Safety Lab

Tel: 886-3-3183232

Fax: 886-3-3270892

**Email:** [service.adt@tw.bureauveritas.com](mailto:service.adt@tw.bureauveritas.com)

**Web Site:** [www.bureauveritas-adt.com](http://www.bureauveritas-adt.com)

The address and road map of all our labs can be found in our web site also.

--- END ---