

Giant Electronics Ltd.

Application
For
Class II Permissive Change

Two Way Radio with GMRS and FRS

(FCC ID: K7GT5500)

0519822
TL/ Ann Choy
December 15, 2005

- The test results reported in this report shall refer only to the sample actually tested and shall not refer or be deemed a refer to bulk from which such a sample may be said to have been obtained.
- This report shall not be reproduced except in full without prior authorization from Intertek Testing Services Hong Kong Limited
- For Terms And Conditions of the services, it can be provided upon request.
- The evaluation data of the report will be kept for 3 years from the date of issuance.

Intertek Testing Services Hong Kong Ltd.

2/F., Garment Centre, 576 Castle Peak Road, Kowloon, Hong Kong.

Tel: (852) 2173 8888 Fax: (852) 2371 0521 Website: www.hk.intertek-etlsemko.com

INTERTEK TESTING SERVICES

SUMMARY OF CONTENTS

LIST OF EXHIBITS

<i>EXHIBIT 1:</i>	General Description
<i>EXHIBIT 2:</i>	System Test Configuration
<i>EXHIBIT 3:</i>	Modulation Characteristics
<i>EXHIBIT 4:</i>	Occupied Bandwidth
<i>EXHIBIT 5:</i>	Spurious Emission
<i>EXHIBIT 6:</i>	Frequency Stability
<i>EXHIBIT 7:</i>	Technical Specifications
<i>EXHIBIT 8:</i>	Product Labelling
<i>EXHIBIT 9:</i>	Photographs
<i>EXHIBIT 10:</i>	Instruction Manual
<i>EXHIBIT 11:</i>	Tune Up Procedure
<i>EXHIBIT 12:</i>	Part List
<i>EXHIBIT 13:</i>	Input Current
<i>EXHIBIT 14:</i>	RF Exposure Info
<i>EXHIBIT 15:</i>	Confidentiality Request

INTERTEK TESTING SERVICES

MEASUREMENT/TECHNICAL REPORT

Application : Giant Electronics Ltd.
Trade Name/Model No : Motorola T5570
Date : December 15, 2005

This report concerns (check one:) Original Grant _____ Class II Change X

Equipment Type: FRF – Part 95 Family Radio Face Held Transmitter

Deferred grant requested per 47 CFR 0.457(d)(1)(ii)? Yes _____ No X

If yes, defer until: _____
date

Company Name agrees to notify the Commission by: _____
date

of the intended date of announcement of the product so that the grant can be issued on that date.

Report prepared by: Tommy Leung
Intertek Testing Services Hong Kong Ltd.
2/F., Garment Centre,
576 Castle Peak Road,
Kowloon, Hong Kong.
Phone: 852-2173-8538
Fax: 852-2741-1693

INTERTEK TESTING SERVICES

Table of Contents

1.0 <u>General Description</u>	2
1.1 Product Description	2
1.2 Purpose of Application	3
1.3 Test Methodology.....	3
1.4 Test Facility	3
2.0 <u>System Test Configuration</u>	5
2.1 Justification	5
2.2 EUT Exercising Software	6
2.3 Special Accessories	6
2.4 Measurement Uncertainty.....	6
2.5 Equipment Modification	6
2.6 Support Equipment.....	6
3.0 <u>Modulation Characteristics (Section 95.637(a))</u>	8
3.1 Modulation Frequency Response	9
3.2 Modulation Limiting Characteristic	11
3.3 Audio Low Pass Filter Response	13
4.0 <u>Occupied Bandwidth (Section 95.633(c))</u>	15
5.0 <u>Spurious Emission (Section 95.635(b))</u>	17
5.1 Field Strength of Spurious Radiation.....	18
6.0 <u>Frequency Stability (Section 95.627)</u>	24
6.1 Frequency Tolerance	25
6.2 Temperature Extreme Condition	27
6.3 Voltage Extreme Condition	30
7.0 <u>Technical Specifications</u>	33
8.0 <u>Product Labelling</u>	37
9.0 <u>Equipment Photographs</u>	40
10.0 <u>Instruction Manual</u>	42
11.0 <u>Tune Up Procedure</u>	44
12.0 <u>Part List</u>	46
13.0 <u>Input Current</u>	48
14.0 <u>RF Exposure Info</u>	50
15.0 <u>Confidentiality Request</u>	52

INTERTEK TESTING SERVICES

List of attached file

Exhibit type	File Description	Filename
Cover Page	Purpose of Application	product change.pdf
Operation Description	Technical Description	descri.pdf
Test Report	Bandwidth Plot	bw.pdf
Test Report	Modulation Frequency Response	mfr.pdf
Test Report	Modulation Limit Characteristic	mlc.pdf
Test Report	Spurious Emission	spurious.pdf
Block Diagram	Block Diagram	block.pdf
Schematics	Circuit Diagram	circuit.pdf
ID Label/Location	Label Artwork and Location	label.pdf
User Manual	User Manual	manual.pdf
Test Report	Test Report	report.pdf
Test Setup Photo	Radiated Emission	config photos.doc
Internal Photo	Internal Photo	internal photos.doc
External Photo	External Photo	external photos.doc
Test Report	Audio Low Pass Filter Response	lpf.pdf
Test Report	Tune Up Procedure	tuneup.pdf
Test Report	Part List	partlist.pdf
Cover Letter	Confidentiality Request	request.pdf
RF Exposure Info	SAR Test Report	SAR report.pdf

INTERTEK TESTING SERVICES

EXHIBIT 1

GENERAL DESCRIPTION

INTERTEK TESTING SERVICES

1.0 General Description

1.1 Product Description

The Equipment Under Test (EUT) is a Two Way Radio with GMRS and FRS operating between 462.5500MHz and 467.7125MHz. The EUT is powered by 3.6V (1 x 3.6V "Ni-MH" type rechargeable battery) or 4.5V (3 x "AA" size 1.5V alkaline batteries). According to the user manual instructions, the EUT is turned off while in charging tray.

Transmitter Portion

- (i) Type of Emission : GMRS: 10K5F3E; FRS: 10K4F3E
- (ii) Frequency Range : GMRS 15 Channels from 462.5500MHz to 462.7250MHz
FRS 7 Channels from 467.5625MHz to 467.7125MHz
- (iii) Maximum Power Rating : GMRS: 0.275W ERP; FRS: 0.265W ERP
- (iv) Antenna Type : Integral

The brief circuit description is saved with filename: descri.pdf

INTERTEK TESTING SERVICES

1.2 Purpose of Application

The purpose of application is saved with filename: product change.pdf.

As the RF module remains unchanged and the base band circuit is changed, the following test results are included in this report.

1. Modulation Characteristics
2. Occupied Bandwidth
3. Spurious Emission
4. Frequency Stability

1.3 Test Methodology

Radiated emission measurements were performed according to the procedures in ANSI C63.4 (2003) and ANSI/TIA-603-B-2002. All measurement were performed in Open Area Test Sites. Preliminary scans were performed in the Open Area Test Sites only to determine worst case modes. For each scan, the procedure of maximizing emissions in Appendices D and E were followed. All Radiated tests were performed at an antenna the EUT distance of 3 meters, unless stated otherwise in the “**Justification Section**” of this Application.

1.4 Test Facility

The open area test site and conducted measurement facility used to collect the emission data is located at Garment Centre, 576 Castle Peak Road, Kowloon, Hong Kong. The test facility and site measurement data have been fully placed on file with the FCC.

INTERTEK TESTING SERVICES

EXHIBIT 2

SYSTEM TEST CONFIGURATION

INTERTEK TESTING SERVICES

2.0 System Test Configuration

2.1 Justification

The device was configured for testing in a typical fashion (as a customer would normally use it). The device was placed on a turntable, which enabled the engineer to maximize emissions through its placement in the three orthogonal axes. When the radiated emissions are measured.

The device was powered by 3 new "AA" size 1.5V alkaline batteries.

The frequency range from 30 MHz to 4.69 GHz was searched for spurious emissions from the device. Only those emissions reported were detected. All other emissions were at least 20 dB below the applicable limits.

INTERTEK TESTING SERVICES

2.2 EUT Exercising Software

There was no special software to exercise the device. Once the unit is powered on, a signal is transmitted.

2.3 Special Accessories

No special accessory is needed for compliance of this device.

2.4 Measurement Uncertainty

When determining of the test conclusion, the Measurement Uncertainty of test has been considered.

2.5 Equipment Modification

Any modification installed previous to testing by Giant Electronics Ltd. will be incorporated in each production model sold/leased in the United States.

No modification were installed by Intertek Testing Services Hong Kong Ltd.

2.6 Support Equipment

A headset with 1.2m unshielded cable. (Supplied by Client)

Confirmed by:

*Tommy Leung
Assistant Manager
Intertek Testing Services
Agent for Giant Electronics Ltd.*



_____ Signature

_____ December 15, 2005 _____ Date

INTERTEK TESTING SERVICES

EXHIBIT 3

MODULATION CHARACTERISTICS

INTERTEK TESTING SERVICES

3.0 Modulation Characteristics

In order to satisfy the 95.637(a) requirement, Modulation Frequency Response and Modulation Limit Characteristics are attached in Exhibit 4.1 & 4.2.

Plots for each tests are saved with filename: mfr.pdf and mlc.pdf

INTERTEK TESTING SERVICES

3.1 Modulation Frequency Response

A. Test Equipment

Equipment	Brand Name	Model No.
Audio Signal Generator	HP	HP8904A
AC Millivoltmeter	Leader	LMV-182A
20 dB RF Attenuator	Bird	8304-200-N
Communication Service Monitor	Marconi	2945

B. Testing Procedure

- 1) Set-up the test equipment in the following configuration:

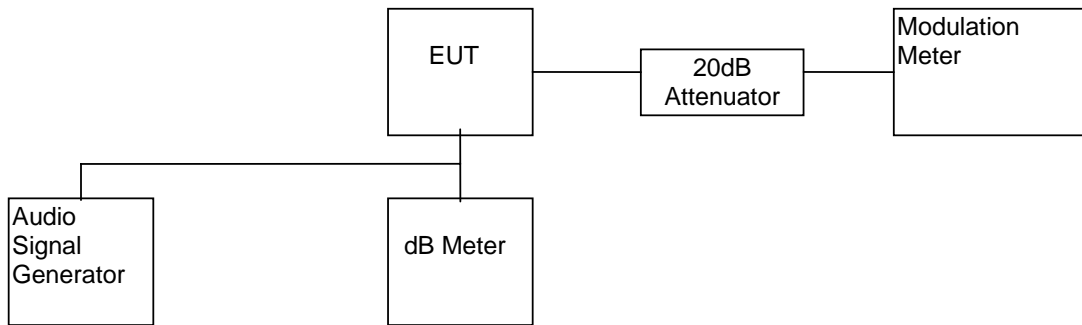

- 2) Set the audio signal generator frequency to the sound pressure level 102dB SPL at the microphone of the EUT.
- 3) The frequency of the audio signal generator is changed from 300Hz to 5kHz.
- 4) Record the frequency deviation.

INTERTEK TESTING SERVICES

C. Test Result

Table 1

**Giant Electronics Ltd.
Motorola T5570**

Modulation Frequency Response

Test Channel : 4
Input level = 102dBSPL

Modulation Frequency (Hz)	Modulation index (%)
300	0.42
400	1.36
500	1.34
600	1.77
700	1.96
800	2.15
900	1.94
1000	1.85
1250	1.62
1500	1.39
1750	1.25
2000	0.97
2250	0.75
2500	0.50
2750	0.49
3000	0.57
3125	0.54
3250	0.50
3500	0.40
4000	0.25
5000	0.11

Test Engineer: Kenneth C. C. Lam Date of Test: September 21-December 5, 2005

INTERTEK TESTING SERVICES

3.2 Modulation Limiting Characteristics (Section 2.1047(b))

A. Test Equipment

Equipment	Brand Name	Model No.
Audio Signal Generator	HP	HP8904A
20 dB RF Attenuator	Bird	8304-200-N
Communication Service Monitor	Marconi	2945

B. Testing Procedure

- 1) Set-up the test equipment in the following configuration:

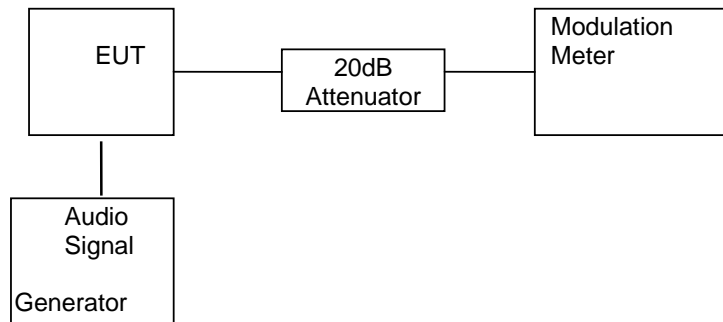

- 2) Set the frequency of the audio signal generator to 500Hz and adjust the level from 47dBSPL to 137dBSPL.
- 3) Record the maximum value of plus or minus peak frequency deviation.
- 4) Repeat the above procedure with frequency 1000Hz, 2500Hz & 3125Hz.

INTERTEK TESTING SERVICES

C. Test Result

Table 2

**Giant Electronics Ltd.
Motorola T5570**

Modulation Limiting Characteristics

Test Channel : 4

Modulation Input (dB SPL)	Peak Frequency Deviation (kHz) at 500Hz	Peak Frequency Deviation (kHz) at 1000Hz	Peak Frequency Deviation (kHz) at 2500Hz	Peak Frequency Deviation (kHz) at 3125Hz
47	0.042	0.042	0.042	0.042
57	0.042	0.043	0.043	0.043
67	0.043	0.055	0.044	0.050
77	0.048	0.102	0.063	0.098
87	0.085	0.542	0.154	0.514
97	0.451	1.553	0.774	1.518
107	1.116	2.035	1.918	1.704
117	1.948	2.058	1.951	1.612
127	2.028	2.088	1.951	1.562
137	2.044	2.145	1.984	1.542

Test Engineer: Kenneth C. C. Lam

Date of Test: September 21-December 5, 2005

INTERTEK TESTING SERVICES

3.3 Audio Low Pass Filter Response (Section 95.637(b))

A. Test Equipment

Equipment	Brand Name	Model No.
Audio Signal Generator	HP	HP8904A
AC Millivoltmeter	Leader	LMV-182A

B. Testing Procedure

- 1) Connect the audio signal generator to the input of the post limiter low pass filter and the dB meter to the output of the post limiter low pass filter.
- 2) Apply a 1000 Hz tone from the audio signal generator and adjust the level per manufacturer's specifications. Record the dB level of the 1000 Hz tone as LEV_{REF} .
- 3) Set the audio signal generator to the desired test frequency between 3000 Hz and the upper low pass filter limit. Record the dB level at the test frequency as LEV_{FREQ} .
- 4) Calculate the audio frequency response at the test frequency as:

$$\text{low pass filter response} = LEV_{FREQ} - LEV_{REF}$$

- 1) Repeat the above procedure for all the desired test frequencies.

C. Test Result

For electronic filing, the audio low pass frequency response is saved with filename: lpf.pdf.

INTERTEK TESTING SERVICES

EXHIBIT 4

OCCUPIED BANDWIDTH

INTERTEK TESTING SERVICES

4.0 Occupied Bandwidth (Section 95.633(c))

A. Test Equipment

Equipment	Brand Name	Model No.
Audio Signal Generator	HP	HP8904A
AC Millivoltmeter	Leader	LMV-182A
20 dB RF Attenuator	Bird	8304-200-N
Spectrum Analyzer	HP	8951EM

B. Testing Procedure

- 1) Set-up the test equipment in the following configuration:

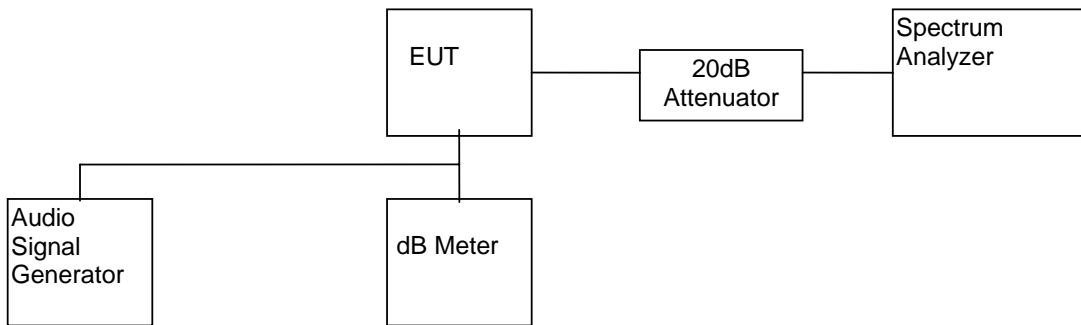

- 2) Set the level of audio signal generator to obtain 16 dB greater than required for 50% modulation.
- 3) The occupied bandwidth is measured with the spectrum analyzer set at 2kHz/div scan and 10dB/div.

C. Test Result

The occupied Bandwidth is measured to be 10.45 kHz for GMRS and 10.35kHz for FRS.

For the electronic filing, the bandwidth plot is saved with filename: bw.pdf

Test Engineer: Kenneth C. C. Lam

Date of Test: September 21-December 5, 2005

INTERTEK TESTING SERVICES

EXHIBIT 5

SPURIOUS EMISSION

INTERTEK TESTING SERVICES

5.0 **Spurious Emission (Section 95.635)**

In order to satisfy the 95.635 requirement, the spurious emission from the EUT are measured and shown in the Exhibit 6.1.

INTERTEK TESTING SERVICES

5.1 Field Strength of Spurious Radiation (Section 95.635)

A. Test Equipment

Equipment	Brand Name	Model No.
Antenna	EMCO	A100, 3148, 3104C, 3115
Spectrum Analyzer	ADVANTEST	R3271
Test receiver	Rohde & Schwarz	ESVS30
RF Filter	Trilithic	3VF500/1000-5-50-CC

B. Testing Procedure

Radiated emission measurements were performed according to the procedures in ANSI C63.4(2003). All measurements were performed in Open Area Test Sites located at Roof Top of Garment Centre, 576 Castle Peak Road, Kowloon, Hong Kong.

INTERTEK TESTING SERVICES

C. Radiated Emission Configuration Photograph

Worst Case Radiated Emission

For electronic filing, the radiated emission configurations photograph is saved with filename: config photos.doc

INTERTEK TESTING SERVICES

C. Test Result

**Giant Electronics Ltd.
Motorola T5570**

Table 3(a)

1) Unwanted emission from CARRIER $\pm 6.25\text{kHz}$ to CARRIER $\pm 31.25\text{kHz}$

(Refer to the plots which is saved with filename: spurious.pdf)

Region	Unwanted emission	
	Channel 4	Channel 11
CARRIER $\pm 6.25\text{kHz}$ to $\pm 12.5\text{kHz}$	<25dB	<25dB
CARRIER $\pm 12.5\text{kHz}$ to $\pm 31.25\text{kHz}$	<35dB	<35dB

INTERTEK TESTING SERVICES

Table 3(b): Channel 4

Frequency (MHz)	Effective Radiated Power (dBm)	Transmission Power (dBm)	Attenuation (dBc)	Limit (dB)	Margin (dB)
231.318	-61.4	24.4	85.8	37.4	-48.4
693.955	-49.8	24.4	74.2	37.4	-36.8
925.274	-20.6	24.4	45.0	37.4	-7.6
1387.913	-32.6	24.4	57.0	37.4	-19.6
1850.550	-32.8	24.4	57.2	37.4	-19.8
2313.185	-28.8	24.4	53.2	37.4	-15.8
2775.822	-33.9	24.4	58.3	37.4	-20.9
3238.460	-34.9	24.4	59.3	37.4	-21.9
3701.097	-35.4	24.4	59.8	37.4	-22.4
4163.735	-39.4	24.4	63.8	37.4	-26.4

- Remark: 1. Transmission power is 24.4 dBm or -5.6 dB(W).
2. According to Section 95.635(b7), the unwanted emission should be attenuated below TP by at least $43 + 10 \log_{10} (TP)$ dB or 37.4 dB.
3. The test is performed according to ANSI/TIA-603-B-2002.

Test Engineer: Kenneth C. C. Lam

Date of Test: September 21-December 5, 2005

INTERTEK TESTING SERVICES

Table 3(b): Channel 11

Frequency (MHz)	Effective Radiated Power (dBm)	Transmission Power (dBm)	Attenuation (dBc)	Limit (dB)	Margin (dB)
233.818	-45.6	24.2	69.8	37.2	-32.6
701.456	-47.9	24.2	72.1	37.2	-34.9
935.275	-25.9	24.2	50.1	37.2	-12.9
1402.914	-33.5	24.2	57.7	37.2	-20.5
1870.555	-36.8	24.2	61.0	37.2	-23.8
2338.188	-36.9	24.2	61.1	37.2	-23.9
2805.824	-34.9	24.2	59.1	37.2	-21.9
3273.462	-36.4	24.2	60.6	37.2	-23.4
3741.099	-35.8	24.2	60.0	37.2	-22.8
4208.732	-38.9	24.2	63.1	37.2	-25.9

- Remark: 1. Transmission power is 24.2 dBm or -5.8 dB(W).
2. According to Section 95.635(b7), the unwanted emission should be attenuated below TP by at least $43 + 10 \log_{10} (TP)$ dB or 37.2 dB.
3. The test is performed according to ANSI/TIA-603-B-2002.

Test Engineer: Kenneth C. C. Lam

Date of Test: September 21-December 5, 2005

INTERTEK TESTING SERVICES

EXHIBIT 6

FREQUENCY STABILITY

INTERTEK TESTING SERVICES

6.0 Frequency Stability

The frequency tolerance was tested in normal condition & over extreme ambient conditions with respect to voltage and temperature variation.

INTERTEK TESTING SERVICES

6.1 Frequency Tolerance (Section 95.627)

A. Test Equipment

Equipment	Brand Name	Model No.
20 dB RF Attenuator	Bird	8304-200-N
Frequency Counter	Phillips	PM6668

B. Testing Procedure

- 1) Set-up the test equipment in the following configuration:

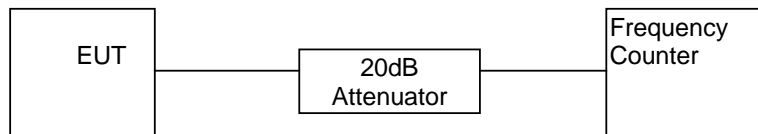

- 2) Measure all transmit channel frequencies in MHz.

INTERTEK TESTING SERVICES

C. Test Result

Table 4

**Giant Electronics Ltd.
Motorola T5570**

Frequency Tolerance

Channel	Frequency (MHz)	Measured Frequency (MHz)	Tolerance (%)
1	462.5625	462.56308	0.000125
2	462.5875	462.58808	0.000125
3	462.6125	462.61308	0.000125
4	462.6375	462.63807	0.000123
5	462.6625	462.66308	0.000125
6	462.6875	462.68808	0.000125
7	462.7125	462.71307	0.000123
8	467.5625	467.56308	0.000124
9	467.5875	467.58808	0.000124
10	467.6125	467.61308	0.000124
11	467.6375	467.63808	0.000124
12	467.6625	467.66307	0.000122
13	467.6875	467.68807	0.000122
14	467.7125	467.71308	0.000124
15	462.5500	462.55058	0.000125
16	462.5750	462.57558	0.000125
17	462.6000	462.60058	0.000125
18	462.6250	462.62557	0.000123
19	462.6500	462.65058	0.000125
20	462.6750	462.67558	0.000125
21	462.7000	462.70058	0.000125
22	462.7250	462.72558	0.000125

INTERTEK TESTING SERVICES

6.2 Frequency Stability - Temperature (Section 2.1055)

A. Test Equipment

Equipment	Brand Name	Model No.
20 dB RF Attenuator	Bird	8304-200-N
Frequency Counter	Phillips	PM6668

B. Testing Procedure

- 1) Set-up the test equipment in the following configuration:

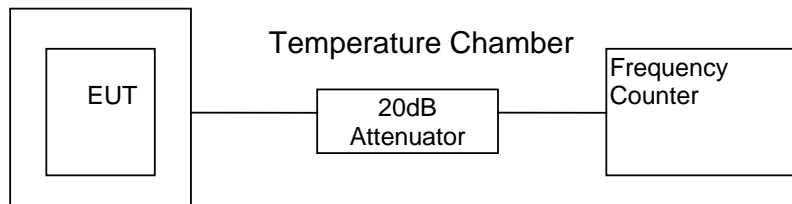

- 2) Set the Temperature Chamber to 20°C and stabilize the EUT temperature for one hour. Set transmitter ON for two minutes.
- 3) Measure the channel frequency of channel 4, 11 in MHz.
- 4) Turn the EUT OFF.
- 5) Repeat the above procedure from -20°C to 50°C with 10°C increment.

INTERTEK TESTING SERVICES

C. Test Result

Table 5(a)

**Giant Electronics Ltd.
Motorola T5570**

Frequency Deviation with Temperature Variation

Channel : 4

Temperature (°C)	Assigned Frequency (MHz)	Measured Frequency (MHz)	Deviation (%)	*Frequency Tolerance with reference to its value at +20°C (ppm)
-20	462.6375	462.63732	-0.000039	-1.6
-10	462.6375	462.63785	0.000076	-0.5
0	462.6375	462.63802	0.000112	-0.1
10	462.6375	462.63814	0.000138	0.2
20	462.6375	462.63807	0.000123	0.0
30	462.6375	462.63781	0.000067	-0.6
40	462.6375	462.63760	0.000022	-1.0
50	462.6375	462.63808	0.000125	0.0

*Remark: This column is presentable for Industry Canada Certification only.

Test Engineer: Kenneth C. C. Lam Date of Test: September 21-December 5, 2005

INTERTEK TESTING SERVICES

C. Test Result

Table 5(b)

**Giant Electronics Ltd.
Motorola T5570**

Frequency Deviation with Temperature Variation

Channel : 11

Temperature (°C)	Assigned Frequency (MHz)	Measured Frequency (MHz)	Deviation (%)	*Frequency Tolerance with reference to its value at +20°C (ppm)
-20	467.6375	467.63730	-0.000043	-1.7
-10	467.6375	467.63787	0.000079	-0.4
0	467.6375	467.63802	0.000111	-0.1
10	467.6375	467.63810	0.000128	0.0
20	467.6375	467.63808	0.000124	0.0
30	467.6375	467.63781	0.000066	-0.6
40	467.6375	467.63760	0.000021	-1.0
50	467.6375	467.63807	0.000122	0.0

*Remark: This column is presentable for Industry Canada Certification only.

Test Engineer: Kenneth C. C. Lam Date of Test: September 21-December 5, 2005

INTERTEK TESTING SERVICES

6.3 Frequency Stability - Voltage (Section 2.995)

A. Test Equipment

Equipment	Brand Name	Model No.
Regulated Power Supply	PAD	30-35L
20 dB RF Attenuator	Bird	8304-200-N
Voltage meter	Fluke	87
Frequency Counter	Phillips	PM6668

B. Testing Procedure

- 1) Set-up the test equipment in the following configuration:

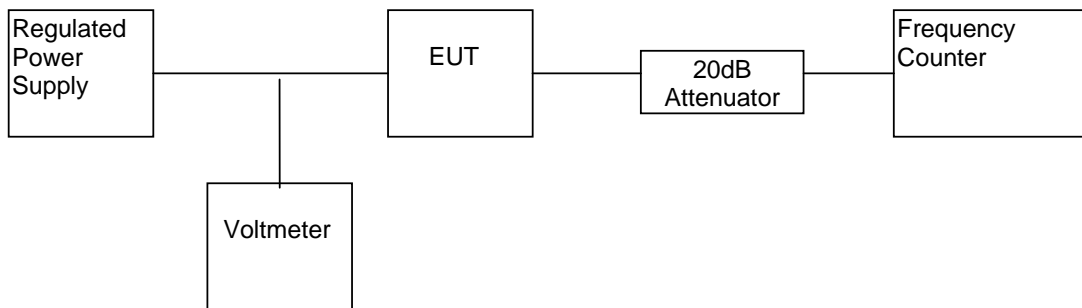

- 2) Vary the level of regulated power supply to the manufacturer specified battery end point of the EUT.
- 3) Measure the channel frequency of channel 4 and 11 in MHz.

INTERTEK TESTING SERVICES

C. Test Result

Table 6

**Giant Electronics Ltd.
Motorola T5570**

Frequency Deviation with Voltage Variation

The manufacturer specified battery end point 3.2V

Channel	Frequency (MHz)	Measured Frequency (MHz)	Tolerance (%)
4	462.63750	462.63796	0.000099
11	467.63750	467.63796	0.000098

INTERTEK TESTING SERVICES

EXHIBIT 7

TECHNICAL SPECIFICATIONS

INTERTEK TESTING SERVICES

7.0 Technical Specifications

INTERTEK TESTING SERVICES

7.1 Block Diagram

For electronic filing, the block diagram of the transceiver is saved with filename:
block.pdf

Figure 7.1 Block Diagram

INTERTEK TESTING SERVICES

7.2 Schematic Diagram

For electronic filing, the schematic diagram of the transceiver is saved with filename: circuit.pdf

Figure 7.2 Schematic Diagram

INTERTEK TESTING SERVICES

EXHIBIT 8

PRODUCT LABELLING

INTERTEK TESTING SERVICES

8.0 Product Labelling

INTERTEK TESTING SERVICES

8.1 Label Artwork & Location

Figure 8.1 Label Artwork & Location

An engineering drawing of the label which will be permanently affixed to the unit.
For electronic filing, the label artwork & location are saved with filename: label.pdf

INTERTEK TESTING SERVICES

EXHIBIT 9
PHOTOGRAPHS

INTERTEK TESTING SERVICES

9.0 Equipment Photographs

For electronic filing, photographs of the tested EUT are saved with filename: external photos.doc and internal photos.doc

INTERTEK TESTING SERVICES

EXHIBIT 10
INSTRUCTION MANUAL

INTERTEK TESTING SERVICES

10.0 Instruction Manual

This manual will be provided to the end-user with each unit sold/leased in the United States.

For electronic filing, a preliminary copy of the Instruction Manual is saved with filename: manual.pdf

INTERTEK TESTING SERVICES

EXHIBIT 11

TUNE UP PROCEDURE

INTERTEK TESTING SERVICES

11.0 Tune Up Procedure

For electronic filing, a preliminary copy of the Tune Up Procedure is saved with filename: tuneup.pdf

INTERTEK TESTING SERVICES

EXHIBIT 12

PART LIST

INTERTEK TESTING SERVICES

12.0 Part List

For electronic filing, a preliminary copy of the Part List is saved with filename:
partlist.pdf

EXHIBIT 13
INPUT CURRENT

13.0 **Input Current**

The input current to final r.f. stage at 4.5VDC is 0.59A.

INTERTEK TESTING SERVICES

EXHIBIT 14

RF EXPOSURE INFO

INTERTEK TESTING SERVICES

14.0 RF Exposure Info

The RF Safety Information is shown on P.1 of User Manual.

For electronic filing, a SAR test is saved with filename: SAR report.pdf

INTERTEK TESTING SERVICES

EXHIBIT 15

CONFIDENTIALITY REQUEST

INTERTEK TESTING SERVICES

15.0 Confidentiality Request

For electronic filing, a confidentiality request is saved with filename: request.pdf