

February 12, 2004

Giant Electronics Ltd.
Elite Industrial Building,
135-137 Hoi Bun Road, Kwun Tong,
Kowloon, Hong Kong.

Dear Mr. Y. K. Ling:

Enclosed you will find your file copy of a Part 95 Certification (FCC ID: K7GT5500).

For your reference, TCB will normally take another 15-20 days for reviewing the report. Approval will then be granted when no query is sorted.

Please contact me if you have any questions regarding the enclosed material.

Sincerely,



Wilson Loke
Manager

Enclosure

Giant Electronics Ltd.

Application
For
Certification
(FCC ID: K7GT5500)

February 12, 2004

0320112
WL/ Ann Choy
February 12, 2004

- The test results reported in this report shall refer only to the sample actually tested and shall not refer or be deemed a refer to bulk from which such a sample may be said to have been obtained.
- This report shall not be reproduced except in full without prior authorization from Intertek Testing Services Hong Kong Limited
- For Terms And Conditions of the services, it can be provided upon request.
- The evaluation data of the report will be kept for 3 years from the date of issuance.

Intertek Testing Services Hong Kong Ltd.

2/F., Garment Centre, 576 Castle Peak Road, Kowloon, Hong Kong.
Tel: (852) 2173 8888 Fax: (852) 2371 0521 Website: www.hk.intertek-etlsemko.com

INTERTEK TESTING SERVICES

SUMMARY OF CONTENTS

LIST OF EXHIBITS

<i>EXHIBIT 1:</i>	General Description
<i>EXHIBIT 2:</i>	System Test Configuration
<i>EXHIBIT 3:</i>	RF Power Output
<i>EXHIBIT 4:</i>	Modulation Characteristics
<i>EXHIBIT 5:</i>	Occupied Bandwidth
<i>EXHIBIT 6:</i>	Spurious Emission
<i>EXHIBIT 7:</i>	Frequency Stability
<i>EXHIBIT 8:</i>	Technical Specifications
<i>EXHIBIT 9:</i>	Product Labelling
<i>EXHIBIT 10:</i>	Photographs
<i>EXHIBIT 11:</i>	Instruction Manual
<i>EXHIBIT 12:</i>	Tune Up Procedure
<i>EXHIBIT 13:</i>	Part List
<i>EXHIBIT 14:</i>	Input Current
<i>EXHIBIT 15:</i>	RF Exposure Info
<i>EXHIBIT 16:</i>	Confidentiality Request

INTERTEK TESTING SERVICES

MEASUREMENT/TECHNICAL REPORT

Application : **Giant Electronics Ltd.**
Trade Name/Model No : **Giant T5500**
 Giant T5510
 Giant T5520
 Giant T5550
Date : **February 12, 2004**

This report concerns (check one:) Original Grant Class II Change _____

Equipment Type: GMRS + FRS

Deferred grant requested per 47 CFR 0.457(d)(1)(ii)? Yes _____ No

If yes, defer until: _____
date

Company Name agrees to notify the Commission by: _____
date

of the intended date of announcement of the product so that the grant can be issued on that date.

Report prepared by:

Wilson Loke
Intertek Testing Services
2/F., Garment Centre,
576 Castle Peak Road,
Kowloon, Hong Kong.
Phone: 852-2173-8575
Fax: 852-2371-0521

INTERTEK TESTING SERVICES

Table of Contents

1.0 <u>General Description</u>	2
1.1 Product Description	2
1.2 Related Submittal(s) Grants	3
1.3 Test Methodology	3
1.4 Test Facility	3
2.0 <u>System Test Configuration</u>	5
2.1 Justification	5
2.2 EUT Exercising Software	6
2.3 Special Accessories	6
2.4 Measurement Uncertainty	6
2.5 Equipment Modification	6
3.0 <u>RF Output Power (Section 95.639(d))</u>	8
4.0 <u>Modulation Characteristics (Section 95.637(a))</u>	12
4.1 Modulation Frequency Response	13
4.2 Modulation Limiting Characteristic	15
4.3 Audio Low Pass Filter Response	17
5.0 <u>Occupied Bandwidth (Section 95.633(c))</u>	19
6.0 <u>Spurious Emission (Section 95.635(b))</u>	21
6.1 Field Strength of Spurious Radiation	22
7.0 <u>Frequency Stability (Section 95.627)</u>	28
7.1 Frequency Tolerance	29
7.2 Temperature Extreme Condition	31
7.3 Voltage Extreme Condition	34
8.0 <u>Technical Specifications</u>	37
9.0 <u>Product Labelling</u>	41
10.0 <u>Equipment Photographs</u>	44
11.0 <u>Instruction Manual</u>	46
12.0 <u>Tune Up Procedure</u>	48
13.0 <u>Part List</u>	50
14.0 <u>Input Current</u>	52
15.0 <u>RF Exposure Info</u>	54
16.0 <u>Confidentiality Request</u>	56

INTERTEK TESTING SERVICES

List of attached file

Exhibit type	File Description	Filename
Operation Description	Technical Description	descri.pdf
Test Report	Bandwidth Plot	bw.pdf
Test Report	Modulation Frequency Response	mfr.pdf
Test Report	Modulation Limit Characteristic	mlc.pdf
Test Report	Spurious Emission	spurious.pdf
Block Diagram	Block Diagram	block.pdf
Schematics	Circuit Diagram	circuit.pdf
ID Label/Location	Label Artwork and Location	label.pdf
User Manual	User Manual	manual.pdf
Test Report	Test Report	report.pdf
Test Setup Photo	Radiated Emission	radiated photos.doc
Internal Photo	Internal Photo	internal photos.doc
External Photo	External Photo	external photos.doc
Test Report	Tune Up Procedure	tuneup.pdf
Test Report	Part List	partlist.pdf
Test Report	Audio Low Pass Filter Response	lpf.pdf
Cover Letter	Confidentiality Request	request.pdf

INTERTEK TESTING SERVICES

EXHIBIT 1

GENERAL DESCRIPTION

INTERTEK TESTING SERVICES

1.0 General Description

1.1 Product Description

The Equipment Under Test (EUT) is a Two Way Radio with FRS and GMRS operating at 462.5500 and 467.7125MHz. The EUT is powered by 4.5V d.c. (3 x 1.5V "AA" size alkaline batteries).

Transmitter Portion

- i) Type of Emission : 10k2F3E
- ii) Frequency Range : FRS 7 Channels from 467.5625 to 467.7125MHz
GMRS 15 Channels from 462.5500 to 462.7250MHz
- iii) Maximum Power Rating : FRS - 0.265W ERP, GMRS - 0.275W ERP
- iv) Antenna Type : Integral

The Model: Giant T5510, Giant T5520 and Giant T5550 are the same as the Model: Giant T5500 in hardware aspect except that Giant T5510 has no 22 RF Channel Scan function and Giant T5520 has 5 call tone only and no VOX function.

For electronic filing, the brief circuit description is saved with filename: descri.pdf

INTERTEK TESTING SERVICES

1.2 Related Submittal(s) Grants

This is an Application for Certification of the transmitter portion of a GMRS + FRS Transceiver. The receiver section of this Transceiver is subject to verification process.

1.3 Test Methodology

Radiated emission measurements were performed according to the procedures in ANSI C63.4 (1992) and ANSI/TIA/EIA-603-1992. All measurement were performed in Open Area Test Sites. Preliminary scans were performed in the Open Area Test Sites only to determine worst case modes. For each scan, the procedure of maximizing emissions in Appendices D and E were followed. All Radiated tests were performed at an antenna the EUT distance of 3 meters, unless stated otherwise in the “**Justification Section**” of this Application.

1.4 Test Facility

The open area test site and conducted measurement facility used to collect the emission data is located at Garment Centre, 576 Castle Peak Road, Kowloon, Hong Kong. The test facility and site measurement data have been fully placed on file with the FCC.

INTERTEK TESTING SERVICES

EXHIBIT 2

SYSTEM TEST CONFIGURATION

INTERTEK TESTING SERVICES

2.0 System Test Configuration

2.1 Justification

The device was configured for testing in a typical fashion (as a customer would normally use it). The device was placed on a turntable, which enabled the engineer to maximize emissions through its placement in the three orthogonal axes. When the radiated emissions are measured.

The device was powered by 3 fully charged 1.5V "AA" alkaline batteries.

The frequency range from 30 MHz to 4.69 GHz was searched for spurious emissions from the device. Only those emissions reported were detected. All other emissions were at least 20 dB below the applicable limits.

INTERTEK TESTING SERVICES

2.2 EUT Exercising Software

There was no special software to exercise the device. Once the unit is powered on, a signal is transmitted.

2.3 Special Accessories

No special accessory is needed for compliance of this device.

A supplied headset is used during the test.

2.4 Measurement Uncertainty

When determining of the test conclusion, the Measurement Uncertainty of test has been considered.

2.5 Equipment Modification

Any modification installed previous to testing by Giant Electronics Ltd. will be incorporated in each production model sold/leased in the United States.

No modification were installed by Intertek Testing Services.

Confirmed by:

*Wilson Loke
Manager
Intertek Testing Services
Agent for Giant Electronics Ltd.*



Signature

February 12, 2004 Date

INTERTEK TESTING SERVICES

EXHIBIT 3

RF POWER OUTPUT

INTERTEK TESTING SERVICES

3.0 **RF Power Output (Section 2.1046(a))**

A. Equipment Used

Equipment	Brand Name	Model No.
Biconical Antenna	CDI	B300
Test receiver	Rohde & Schwarz	ESVS30
RF Filter	Tailithic	3VF
Tuned Dipole Antenna	CDI	Robert Antenna 4
Signal Generator	Maconi	2024

B. Testing Procedure

1. On a test site, the EUT shall be placed at 1.5m height on a turn table, and in the position closest to normal use as declared by the applicant.
2. The test antenna shall be oriented initially for vertical polarisation located 3m from EUT to correspond to the frequency of the transmitter.
3. The output of the test antenna shall be connected to the measuring receiver and the quasi-peak detector is used for the measurement.
4. The transmitter shall be switched on, if possible, without modulation and the measuring receiver shall be tuned to the frequency of the transmitter under test.
5. The test antenna shall be raised and lowered through the specified range of height until a maximum signal level is detected by the measuring receiver.

INTERTEK TESTING SERVICES

6. The transmitter shall then be rotated through 360° in the horizontal plane, until the maximum signal level is detected by the measuring receiver.
7. The test antenna shall be raised and lowered again through the specified range of height until a maximum signal level is detected by the measuring receiver.
8. The maximum signal level detected by the measuring receiver shall be noted.
9. The transmitter shall be replaced by a tuned dipole (substitution antenna).
10. The substitution antenna shall be orientated for vertical polarisation and the length of the substitution antenna shall be adjusted to correspond to the frequency of the transmitter.
11. The substitution antenna shall be connected to a calibrated signal generator.
12. If necessary, the input attenuator setting of the measuring receiver shall be adjusted in order to increase the sensitivity of the measuring receiver.
13. The test antenna shall be raised and lowered through the specified range of height to ensure that the maximum signal is received.
14. The input signal to the substitution antenna shall be adjusted to the level that produces a level detected by the measuring receiver, that is equal to the level noted while the transmitter radiated power was measured, corrected for the change of input attenuator setting of the measuring receiver.
15. The input level to the substitution antenna shall be recorded as power level in dBm, corrected for any change of input attenuator setting of the measuring receiver.
16. The measurement shall be repeated with the test antenna and the substitution antenna orientated for horizontal polarisation.
17. The measure of the effective radiated power is the larger of the two levels recorded, at the input to the substitution antenna, corrected for gain of the substitution antenna if necessary.

INTERTEK TESTING SERVICES

Table 1

**Giant Electronics Ltd.
Giant T5500**

Transmission Power

Channel	Frequency (MHz)	Effective Radiated Power		Limit (W)	Margin (W)
		(dBm)	(W)		
1	462.5625	24.8	0.275	2.0	-1.725
2	462.5875	24.8	0.275	2.0	-1.725
3	462.6125	24.8	0.275	2.0	-1.725
4	462.6375	24.8	0.275	2.0	-1.725
5	462.6625	24.8	0.275	2.0	-1.725
6	462.6875	24.8	0.275	2.0	-1.725
7	462.7125	24.8	0.275	2.0	-1.725
8	467.5625	24.6	0.265	0.5	-0.235
9	467.5875	24.6	0.265	0.5	-0.235
10	467.6125	24.6	0.265	0.5	-0.235
11	467.6375	24.6	0.265	0.5	-0.235
12	467.6625	24.6	0.265	0.5	-0.235
13	467.6875	24.6	0.265	0.5	-0.235
14	467.7125	24.6	0.265	0.5	-0.235
15	462.5500	24.8	0.275	2.0	-1.725
16	462.5750	24.8	0.275	2.0	-1.725
17	462.6000	24.8	0.275	2.0	-1.725
18	462.6250	24.8	0.275	2.0	-1.725
19	462.6500	24.8	0.275	2.0	-1.725
20	462.6750	24.8	0.275	2.0	-1.725
21	462.7000	24.8	0.275	2.0	-1.725
22	462.7250	24.8	0.275	2.0	-1.725

Notes: Negative sign in the margin column shows the value below limits.

Test Engineer: Ben W. K. Ho

Date of Test: February 4, 2004

INTERTEK TESTING SERVICES

EXHIBIT 4

MODULATION CHARACTERISTICS

INTERTEK TESTING SERVICES

4.0 Modulation Characteristics

In order to satisfy the 95.637(a) requirement, Modulation Frequency Response and Modulation Limit Characteristics are attached in Exhibit 4.1 & 4.2.

Plots for each tests are saved with filename: mfr.pdf and mlc.pdf

INTERTEK TESTING SERVICES

4.1 Modulation Frequency Response

A. Test Equipment

Equipment	Brand Name	Model No.
Audio Signal Generator	Leader	LFG-1300S
dB meter	Leader	LMV-182A
20 dB RF Load	Bird	8304-200-N
Modulation Meter	Marconi Instrument	2945

B. Testing Procedure

- 1) Set-up the test equipment in the following configuration:

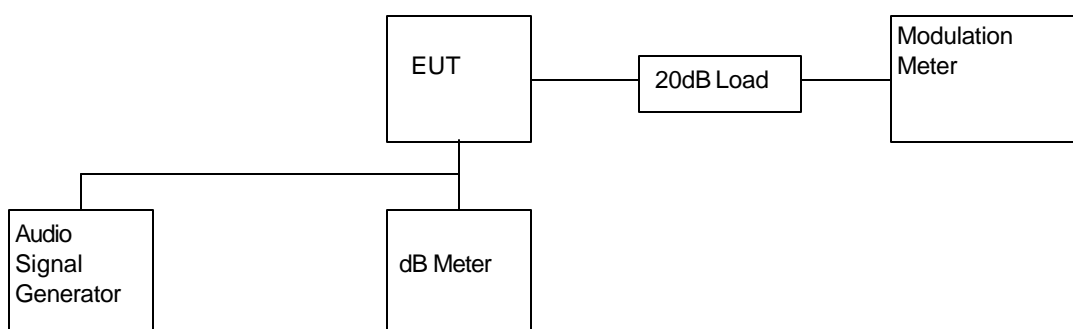

- 2) Set the audio signal generator frequency to the sound pressure level 107 dB SPL at the microphone of the EUT.
- 3) The frequency of the audio signal generator is changed from 300Hz to 5kHz.
- 4) Record the frequency deviation.

INTERTEK TESTING SERVICES

C. Test Result

Table 2

**Giant Electronics Ltd.
Giant T5500**

Modulation Frequency Response

Test Channel : 4
Input level = 107dB SPL

Modulation Frequency (Hz)	Modulation index (%)
300	0.74
400	0.73
500	0.71
600	0.83
700	0.95
800	1.04
900	0.95
1000	1.00
1250	0.89
1500	0.45
1750	0.44
2000	0.46
2250	0.47
2500	0.50
2750	0.45
3000	0.40
3125	0.39
3250	0.37
3500	0.28
4000	0.20
5000	0.08

Test Engineer: Ben W. K. Ho

Date of Test: February 4, 2004

INTERTEK TESTING SERVICES

4.2 Modulation Limiting Characteristics (Section 2.1047(b))

A. Test Equipment

Equipment	Brand Name	Model No.
Audio Signal Generator	Leader	LFG-1300S
20 dB RF Load	Bird	8304-200-N
Modulation Meter	Marconi	2950

B. Testing Procedure

- 1) Set-up the test equipment in the following configuration:

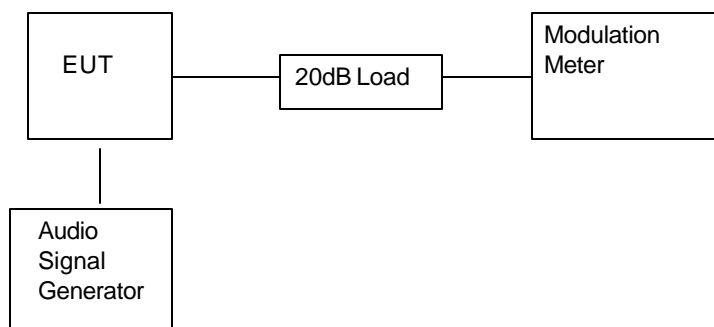

- 2) Set the frequency of the audio signal generator to 500Hz and adjust the level from 47dBSPL to 137dBSPL.
- 3) Record the maximum value of plus or minus peak frequency deviation.
- 4) Repeat the above procedure with frequency 1000Hz, 2500Hz & 3125Hz.

INTERTEK TESTING SERVICES

C. Test Result

Table 3

**Giant Electronics Ltd.
Giant T5500**

Modulation Limiting Characteristics

Test Channel : 4

Modulation Input (dB SPL)	Peak Frequency Deviation (kHz) at 500Hz	Peak Frequency Deviation (kHz) at 1000Hz	Peak Frequency Deviation (kHz) at 2500Hz	Peak Frequency Deviation (kHz) at 3125Hz
47	0.14	0.18	0.19	0.19
57	0.14	0.18	0.20	0.21
67	0.15	0.19	0.21	0.22
77	0.16	0.20	0.23	0.22
87	0.16	0.23	0.32	0.30
97	0.20	0.35	0.57	0.53
107	0.36	0.74	1.24	1.26
117	0.87	1.53	1.52	1.45
127	1.89	1.59	1.56	1.45
137	1.90	1.67	1.71	1.50

Test Engineer: Ben W. K. Ho

Date of Test: February 4, 2004

INTERTEK TESTING SERVICES

4.3 Audio Low Pass Filter Response (Section 95.637(b))

A. Test Equipment

Equipment	Brand Name	Model No.
Audio Signal Generator	Leader	LFG-1300S
dB meter	Leader	LMV-182A

B. Testing Procedure

- 1) Connect the audio signal generator to the input of the post limiter low pass filter and the dB meter to the output of the post limiter low pass filter.
- 2) Apply a 1000 Hz tone from the audio signal generator and adjust the level per manufacturer's specifications. Record the dB level of the 1000 Hz tone as LEV_{REF} .
- 3) Set the audio signal generator to the desired test frequency between 3000 Hz and the upper low pass filter limit. Record the dB level at the test frequency as LEV_{FREQ} .
- 4) Calculate the audio frequency response at the test frequency as:

$$\text{low pass filter response} = LEV_{FREQ} - LEV_{REF}$$

- 5) Repeat the above procedure for all the desired test frequencies.

C. Test Result

For electronic filing, the audio low pass frequency response is saved with filename: lpf.pdf.

INTERTEK TESTING SERVICES

EXHIBIT 5

OCCUPIED BANDWIDTH

INTERTEK TESTING SERVICES

5.0 Occupied Bandwidth (Section 95.633(c))

A. Test Equipment

Equipment	Brand Name	Model No.
Audio Signal Generator	Leader	LFG-1300S
dB meter	Leader	LMV-182A
20 dB RF Load	Bird	8304-200-N
Spectrum Analyzer	Hewlett Packard	8951EM

B. Testing Procedure

- 1) Set-up the test equipment in the following configuration:

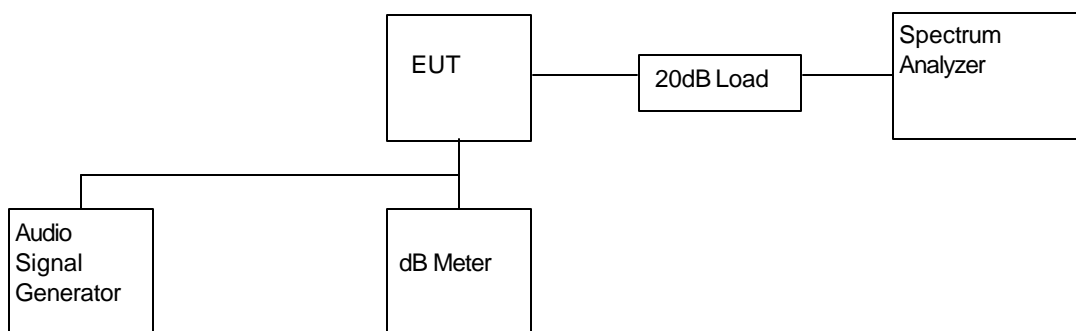

- 2) Set the level of audio signal generator to obtain 16 dB greater than required for 50% modulation.
- 3) The occupied bandwidth is measured with the spectrum analyzer set at 5kHz/div scan and 10dB/div.

C. Test Result

The occupied Bandwidth is measured to be 10.5 kHz.

For the electronic filing, the bandwidth plot is saved with filename: bw.pdf

Test Engineer: Ben W. K. Ho

Date of Test: February 4, 2004

INTERTEK TESTING SERVICES

EXHIBIT 6

SPURIOUS EMISSION

INTERTEK TESTING SERVICES

6.0 **Spurious Emission (Section 95.635)**

In order to satisfy the 95.635 requirement, the spurious emission from the EUT are measured and shown in the Exhibit 6.1.

INTERTEK TESTING SERVICES

6.1 Field Strength of Spurious Radiation (Section 95.635)

A. Test Equipment

Equipment	Brand Name	Model No.
Antenna	CDI	B100,B200,B300, Horn
Test receiver	Rohde & Schwarz	ESVS30
RF Filter	Tailithic	3VF

B. Testing Procedure

Radiated emission measurements were performed according to the procedures in ANSI C63.4(1992). All measurements were performed in Open Area Test Sites located at Roof Top of Garment Centre, 576 Castle Peak Road, Kowloon, Hong Kong.

INTERTEK TESTING SERVICES

C. Radiated Emission Configuration Photograph

Worst Case Radiated Emission

For electronic filing, the radiated emission configurations photograph is saved with filename: radiated photos.doc

INTERTEK TESTING SERVICES

C. Test Result

**Giant Electronics Ltd.
Giant T5500**

Table 4(a)

1. Unwanted emission from CARRIER $\pm 6.25\text{kHz}$ to CARRIER $\pm 31.25\text{kHz}$

(Refer to the plots which is saved with filename: spurious.pdf)

Region	Unwanted emission	
	Channel 4	Channel 11
CARRIER $\pm 6.25\text{kHz}$ to $\pm 12.5\text{kHz}$	$<25\text{dB}$	$<25\text{dB}$
CARRIER $\pm 12.5\text{kHz}$ to $\pm 31.25\text{kHz}$	$<35\text{dB}$	$<35\text{dB}$

INTERTEK TESTING SERVICES

Table 4(b): Channel 4

Frequency (MHz)	Effective Radiated Power (dBm)	Transmission Power (dBm)	Attenuation (dB)	Limit (dB)	Margin (dB)
925.258	-24.2	24.8	49.0	37.8	11.2
1387.890	-35.2	24.8	60.0	37.8	22.2
1850.520	-38.5	24.8	63.3	37.8	25.5
2313.140	-35.1	24.8	59.9	37.8	22.1
2775.770	-36.4	24.8	61.2	37.8	23.4
3238.400	-48.1	24.8	72.9	37.8	35.1
3701.030	-51.6	24.8	76.4	37.8	38.6
4163.660	-49.6	24.8	74.4	37.8	36.6
4626.290	-52.7	24.8	77.5	37.8	39.7

- Remark: 1. Transmission power is 24.8 dBm or -5.2 dB(W).
2. According to Section 95.635(b7), the unwanted emission should be attenuated below TP by at least $43 + 10 \log_{10}(TP)$ dB or 37.8 dB.
3. The test is performed according to ANSI/TIA/EIA -603-1992.

Test Engineer: Ben W. K. Ho

Date of Test: February 4, 2004

INTERTEK TESTING SERVICES

Table 4(b): Channel 11

Frequency (MHz)	Effective Radiated Power (dBm)	Transmission Power (dBm)	Attenuation (dB)	Limit (dB)	Margin (dB)
935.377	-31.2	24.6	55.8	37.6	18.2
1402.890	-34.3	24.6	58.9	37.6	21.3
1870.520	-40.1	24.6	64.7	37.6	27.1
2338.150	-36.6	24.6	61.2	37.6	23.6
2805.790	-36.0	24.6	60.6	37.6	23.0
3273.420	-48.3	24.6	72.9	37.6	35.3
3741.050	-54.2	24.6	78.8	37.6	41.2
4208.680	-49.1	24.6	73.7	37.6	36.1
4676.310	-53.3	24.6	77.9	37.6	40.3

- Remark:
1. Transmission power is 24.6 dBm or -5.4 dB(W).
 2. According to Section 95.635(b7), the unwanted emission should be attenuated below TP by at least $43 + 10 \log_{10}(TP)$ dB or 37.6 dB.
 3. The test is performed according to ANSI/TIA/EIA -603-1992.

Test Engineer: Ben W. K. Ho

Date of Test: February 4, 2004

INTERTEK TESTING SERVICES

EXHIBIT 7

FREQUENCY STABILITY

INTERTEK TESTING SERVICES

7.0 Frequency Stability

The frequency tolerance was tested in normal condition & over extreme ambient conditions with respect to voltage and temperature variation.

INTERTEK TESTING SERVICES

7.1 Frequency Tolerance (Section 95.627)

A. Test Equipment

Equipment	Brand Name	Model No.
Regulated Power Supply	PAD	30-35L
20 dB RF Load	Bird	8304-200-N
Frequency Counter	Phillips	PM6668

B. Testing Procedure

- 1) Set-up the test equipment in the following configuration:

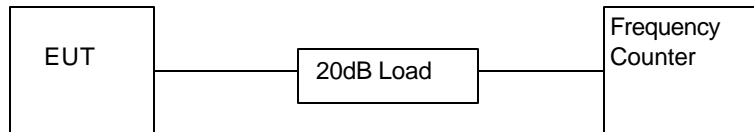

- 2) Measure all transmit channel frequencies in MHz.

INTERTEK TESTING SERVICES

C. Test Result

Table 5

**Giant Electronics Ltd.
Giant T5500**

Frequency Tolerance

Channel	Frequency (MHz)	Measured Frequency (MHz)	Tolerance (%)
1	462.5625	462.56150	-0.000216
2	462.5875	462.58650	-0.000216
3	462.6125	462.61150	-0.000216
4	462.6375	462.63650	-0.000216
5	462.6625	462.66150	-0.000216
6	462.6875	462.68650	-0.000216
7	462.7125	462.71150	-0.000216
8	467.5625	467.56150	-0.000214
9	467.5875	467.58650	-0.000214
10	467.6125	467.61150	-0.000214
11	467.6375	467.63650	-0.000214
12	467.6625	467.66150	-0.000214
13	467.6875	467.68650	-0.000214
14	467.7125	467.71150	-0.000214
15	462.5500	462.54900	-0.000216
16	462.5750	462.57400	-0.000216
17	462.6000	462.59900	-0.000216
18	462.6250	462.62400	-0.000216
19	462.6500	462.64900	-0.000216
20	462.6750	462.67400	-0.000216
21	462.7000	462.69900	-0.000216
22	462.7250	462.72400	-0.000216

INTERTEK TESTING SERVICES

7.2 Frequency Stability - Temperature (Section 2.1055)

A. Test Equipment

Equipment	Brand Name	Model No.
20 dB RF Load	Bird	8304-200-N
Frequency Counter	Phillips	PM6668

B. Testing Procedure

- 1) Set-up the test equipment in the following configuration:

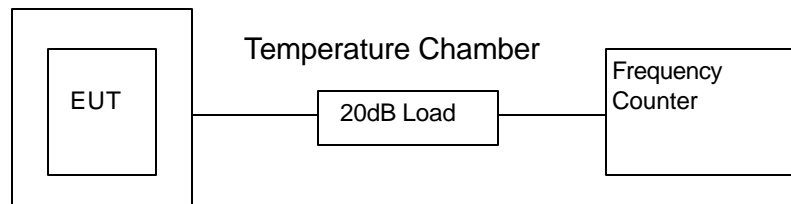

- 2) Set the Temperature Chamber to -20°C and stabilize the EUT temperature for one hour. Set transmitter ON for two minutes.
- 3) Measure the channel frequency of channel 4, 11 in MHz.
- 4) Turn the EUT OFF
- 5) Repeat the above procedure from -20°C to 50°C with 10°C increment.

INTERTEK TESTING SERVICES

C. Test Result

Table 6(a)

**Giant Electronics Ltd.
Giant T5500**

Frequency Deviation with Temperature Variation

Channel : 4

Temperature (°C)	Assigned Frequency (MHz)	Measured Frequency (MHz)	% Deviation
-20	462.6375	462.63825	0.000162
-10	462.6375	462.63850	0.000216
0	462.6375	462.63838	0.000190
10	462.6375	462.63813	0.000136
20	462.6375	462.63650	-0.000216
30	462.6375	462.63675	-0.000162
40	462.6375	462.63688	-0.000134
50	462.6375	462.63763	0.000028

Test Engineer: Ben W. K. Ho

Date of Test: February 4, 2004

INTERTEK TESTING SERVICES

C. Test Result

Table 6(b)

**Giant Electronics Ltd.
Giant T5500**

Frequency Deviation with Temperature Variation

Channel : 11

Temperature (°C)	Assigned Frequency (MHz)	Measured Frequency (MHz)	% Deviation
-20	467.6375	467.63800	0.000107
-10	467.6375	467.63850	0.000214
0	467.6375	467.63838	0.000188
10	467.6375	467.63838	0.000188
20	467.6375	467.63650	-0.000214
30	467.6375	467.63688	-0.000133
40	467.6375	467.63675	-0.000160
50	467.6375	467.63713	-0.000079

Test Engineer: Ben W. K. Ho

Date of Test: February 4, 2004

INTERTEK TESTING SERVICES

7.3 Frequency Stability - Voltage (Section 2.995)

A. Test Equipment

Equipment	Brand Name	Model No.
Regulated Power Supply	PAD	30-35L
20 dB RF Load	Bird	8304-200-N
Voltage meter	Fluke	87
Frequency Counter	Phillips	PM6668

B. Testing Procedure

- 1) Set-up the test equipment in the following configuration:

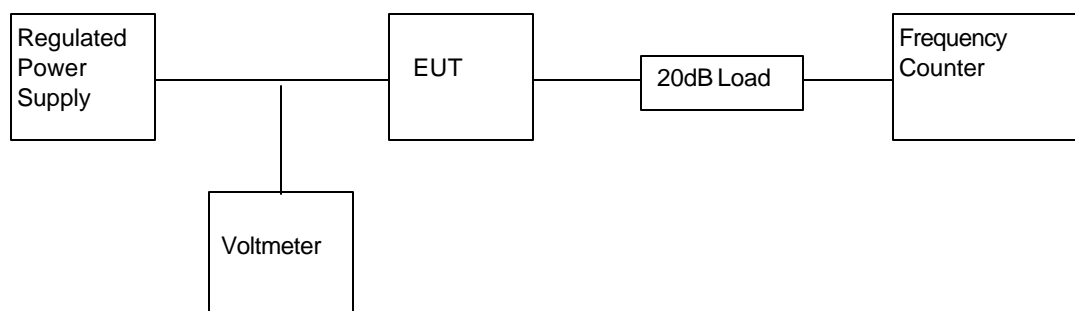

- 2) Vary the level of regulated power supply to the manufacturer specified battery end point of the EUT.
- 3) Measure the channel frequency of channel 4 and 11 in MHz.

INTERTEK TESTING SERVICES

C. Test Result

Table 7

**Giant Electronics Ltd.
Giant T5500**

Frequency Deviation with Voltage Variation

The manufacturer specified battery end point 3.50V

Channel	Frequency (MHz)	Measured Frequency (MHz)	Tolerance (%)
4	462.6375	462.63638	-0.000242
11	467.6375	467.63638	-0.000240

INTERTEK TESTING SERVICES

EXHIBIT 8

TECHNICAL SPECIFICATIONS

INTERTEK TESTING SERVICES

8.0 Technical Specifications

INTERTEK TESTING SERVICES

8.1 Block Diagram

For electronic filing, the block diagram of the FRS is saved with filename: block.pdf

Figure 8.1 Block Diagram

INTERTEK TESTING SERVICES

8.2 Schematic Diagram

For electronic filing, the schematic diagram of the FRS is saved with filename: circuit.pdf

Figure 8.2 SchematicDiagram

INTERTEK TESTING SERVICES

EXHIBIT 9

PRODUCT LABELLING

INTERTEK TESTING SERVICES

9.0 Product Labelling

INTERTEK TESTING SERVICES

9.1 Label Artwork & Location

Figure 9.1 Label Artwork & Location

An engineering drawing of the label which will be permanently affixed to the unit.
For electronic filing, the label artwork & location are saved with filename: label.pdf

INTERTEK TESTING SERVICES

EXHIBIT 10

PHOTOGRAPHS

INTERTEK TESTING SERVICES

10.0 Equipment Photographs

For electronic filing, photographs of the tested EUT are saved with filename: external photos.doc and internal photos.doc

INTERTEK TESTING SERVICES

EXHIBIT 11

INSTRUCTION MANUAL

INTERTEK TESTING SERVICES

11.0 Instruction Manual

This manual will be provided to the end-user with each unit sold/leased in the United States.

For electronic filing, a preliminary copy of the Instruction Manual is saved with filename: manual.pdf

INTERTEK TESTING SERVICES

EXHIBIT 12

TUNE UP PROCEDURE

INTERTEK TESTING SERVICES

12.0 Tune Up Procedure

For electronic filing, a preliminary copy of the Tune Up Procedure is saved with filename: tuneup.pdf

INTERTEK TESTING SERVICES

EXHIBIT 13

PART LIST

INTERTEK TESTING SERVICES

13.0 Part List

For electronic filing, a preliminary copy of the Part List is saved with filename:
partlist.pdf

INTERTEK TESTING SERVICES

EXHIBIT 14
INPUT CURRENT

INTERTEK TESTING SERVICES

14.0 Input Current

The input current to final r.f. stage at 4.5V is 0.6A.

INTERTEK TESTING SERVICES

EXHIBIT 15

RF EXPOSURE INFO

INTERTEK TESTING SERVICES

15.0 RF Exposure Info

The RF Safety Information is shown on P.3 - P. 10 of User Manual.

INTERTEK TESTING SERVICES

EXHIBIT 16

CONFIDENTIALITY REQUEST

INTERTEK TESTING SERVICES

16.0 Confidentiality Request

The applicant would like to have confidential protection of the following documents:

- Schematic
- Block Diagram
- Operation Description

For electronic filing, the request letter is saved with filename: request.pdf.