

**Giant Electronics Ltd.**

Application  
For  
Certification

Two Way Radio with GMRS, FRS, and Weather Band Receiver

**(FCC ID: K7GMHBCJ)**

HK08110551-1  
TL/ ac  
January 16, 2009

- The test report only allows to be revised the retention period issued date unless further standard or the requirement was noticed.
- This report is for the exclusive use of Intertek's Client and is provided pursuant to the agreement between Intertek and its Client. Intertek's responsibility and liability are limited to the terms and conditions of the agreement. Intertek assumes no liability to any party, other than to the Client in accordance with the agreement, for any loss, expense or damage occasioned by the use of this report. Only the Client is authorized to permit copying or distribution of this report and then only in its entirety. Any use of the Intertek name or one of its marks for the sale or advertisement of the tested material, product or service must first be approved in writing by Intertek. The observations and test results in this report are relevant only to the sample tested. This report by itself does not imply that the material, product, or service is or has ever been under an Intertek certification program.

**Intertek Testing Services Hong Kong Ltd.**

2/F., Garment Centre, 576 Castle Peak Road, Kowloon, Hong Kong.  
Tel: (852) 2173 8888 Fax: (852) 2785 5487 Website: [www.hk.intertek-etlsemko.com](http://www.hk.intertek-etlsemko.com)

---

# INTERTEK TESTING SERVICES

---

## SUMMARY OF CONTENTS

### LIST OF EXHIBITS

<i>EXHIBIT 1:</i>	General Description
<i>EXHIBIT 2:</i>	System Test Configuration
<i>EXHIBIT 3:</i>	RF Power Output
<i>EXHIBIT 4:</i>	Modulation Characteristics
<i>EXHIBIT 5:</i>	Occupied Bandwidth
<i>EXHIBIT 6:</i>	Spurious Emission
<i>EXHIBIT 7:</i>	Frequency Stability

# INTERTEK TESTING SERVICES

---

## MEASUREMENT/TECHNICAL REPORT

**Applicant** : Giant Electronics Ltd.  
**Trade Name/Model No** : Motorola MH230  
**Date** : January 16, 2009

This report concerns (check one:) Original Grant  Class II Change

Equipment Type: FRF – Part 95 Family Radio Face Held Transmitter  
CXX - Communications Rcvr for use w/ licensed Tx and CBs

Deferred grant requested per 47 CFR 0.457(d)(1)(ii)? Yes  No   
If yes, defer until: \_\_\_\_\_  
date

Company Name agrees to notify the Commission by: \_\_\_\_\_  
date

of the intended date of announcement of the product so that the grant can be issued on that date.

---

Report prepared by: Leung Wai Leung, Tommy  
Intertek Testing Services Hong Kong Ltd.  
2/F., Garment Centre,  
576 Castle Peak Road,  
Kowloon, Hong Kong.  
Phone: 852-2173-8538  
Fax: 852-2741-1693

---

# INTERTEK TESTING SERVICES

---

## Table of Contents

<b>1.0 General Description</b> .....	5
1.1 Product Description .....	5
1.2 Related Submittal(s) Grants.....	6
1.3 Test Methodology.....	6
1.4 Test Facility .....	6
<b>2.0 System Test Configuration</b> .....	8
2.1 Justification .....	8
2.2 EUT Exercising Software.....	9
2.3 Special Accessories .....	9
2.4 Measurement Uncertainty.....	9
2.5 Equipment Modification .....	9
2.6 Support Equipment.....	10
<b>3.0 RF Power Output (Section 2.1046(a), 95.639(d))</b> .....	12
<b>4.0 Modulation Characteristics (Section 2.1047(a)(b), 95.637(a))</b> .....	16
4.1 Modulation Frequency Response .....	17
4.2 Modulation Limiting Characteristics .....	19
4.3 Audio Low Pass Filter Response.....	21
<b>5.0 Occupied Bandwidth (Section 95.633(c))</b> .....	24
<b>6.0 Spurious Emission</b> .....	27
6.1 Field Strength of Spurious Radiation (Section 2.1053, 95.635(b)).....	28
6.2 Field Strength of Radiation Emission and AC line Conducted Emission (Section 15.109 & 15.107) – Weather Band Receiver .....	35
<b>7.0 Frequency Stability (Section 2.1055(a)(b)(d), 95.627(b))</b> .....	44
7.1 Frequency Tolerance.....	45
7.2 Temperature Extreme Condition.....	47
7.3 Voltage Extreme Condition .....	50
<b>Appendix - Exhibits of Application for Certification</b>	

# **INTERTEK TESTING SERVICES**

---

## **EXHIBIT 1**

### **GENERAL DESCRIPTION**

## **INTERTEK TESTING SERVICES**

---

### **1.0 General Description**

#### **1.1 Product Description**

The Equipment Under Test (EUT) is a Two Way Radio with GMRS, FRS, and Weather Band Receiver. GMRS and FRS radio operating between 462.5500MHz and 467.7125MHz. Weather band receiver operating between 161.650MHz and 162.550MHz. The EUT is powered by 3.6V (1 x 3.6V "Ni-MH" type rechargeable battery) or 4.5V (3 x "AAA" size 1.5V alkaline batteries). Power adaptor, USB port from computer and charging cradle can be alternative power sources.

##### Transmitter Portion

- (i) Type of Emission : GMRS: 5K60F3E; FRS: 5K60F3E
- (ii) Frequency Range : GMRS 15 Channels from 462.5500MHz to 462.7250MHz  
FRS 7 Channels from 467.5625MHz to 467.7125MHz
- (iii) Maximum Power Rating : GMRS: 1.05W ERP; FRS: 0.35W ERP
- (iv) Antenna Type : Integral

The brief circuit description is saved with filename: descri.pdf

## INTERTEK TESTING SERVICES

---

### 1.2 Related Submittal(s) Grants

This is an Application for Certification of the transmitter portion of a GMRS + FRS Transceiver and Weather Band Receiver respectively. The receiver section of this Transceiver is subject to verification process.

### 1.3 Test Methodology

Radiated emission measurements were performed according to the procedures in ANSI C63.4 (2003) and ANSI/TIA-603-C-2004. All measurement were performed in Open Area Test Sites. Preliminary scans were performed in the Open Area Test Sites only to determine worst case modes. All Radiated tests were performed at an antenna the EUT distance of 3 meters, unless stated otherwise in the “**Justification Section**” of this Application.

### 1.4 Test Facility

The open area test site used to collect the emission data is located at Garment Centre, 576 Castle Peak Road, Kowloon, Hong Kong. The test facility and site measurement data have been fully placed on file with the FCC.

**INTERTEK TESTING SERVICES**

---

**EXHIBIT 2**

**SYSTEM TEST CONFIGURATION**



## INTERTEK TESTING SERVICES

---

### 2.0 **System Test Configuration**

#### 2.1 Justification

The device was configured for testing in a typical fashion (as a customer would normally use it). The device was placed on a turntable, which enabled the engineer to maximize emissions through its placement in the three orthogonal axes. The device has been tested with headset and without headset when the radiated emissions are measured.

The frequency range from 30MHz to 10<sup>th</sup> harmonics was searched for spurious emissions from the device. Only those emissions reported were detected. All other emissions were at least 20 dB below the applicable limits.

The device supported several power-up methods (powered by rechargeable battery pack, alkaline batteries, charging cradle, adaptor and DC source from computer's USB port). All power-up methods were tested and the worst-case data was reported.

## INTERTEK TESTING SERVICES

---

### 2.2 EUT Exercising Software

There was no special software to exercise the device. Once the PTT button was pushed, a signal was transmitted.

### 2.3 Special Accessories

No special accessory is needed for compliance of this device.

### 2.4 Measurement Uncertainty

When determining of the test conclusion, the Measurement Uncertainty of test has been considered.

Uncertainty and Compliance - Unless the standard specifically states that measured values are to be extended by the measurement uncertainty in determining compliance, all compliance determinations are based on the actual measured value.

### 2.5 Equipment Modification

Any modification installed previous to testing by Giant Electronics Ltd. will be incorporated in each production model sold/leased in the United States.

No modification were installed by Intertek Testing Services Hong Kong Ltd.

## INTERTEK TESTING SERVICES

---

### 2.6 Support Equipment

1. A headset with 1.2 m unshielded cable. (Supplied by Intertek)
2. 1 x USB cable with 1 meter long (Supplied by Client)
3. An ac adaptor for charging tray: 120VAC, 60Hz, 4W to 9VAC, 200mA, Model no: DV-0920ACS (Supplied by Client)
4. An ac adaptor with USB jack: 100-240VAC, 50/60Hz, 0.2A to 5.0VDC, 200mA, Model No: SSA-5W-05 US 050020F (Supplied by Client)
5. Notebook, Brand: Lenovo, Model: T61, S/N: L3-CF468 (Supplied by Intertek)
6. External 1394 HDD, Brand: Smart-drive, Model: HD3-SU2FW, S/N: 0800261 (HDD: Seagate 120GB, Model: ST912017AS, S/N: 5RE031DT) (Supplied by Intertek)
7. HP Notebook, Model: NX6320, S/N: CNU6370FWN, DoC Product (Supplied by Intertek)
8. HP Printer, Model: C6431D, S/N: CN23B 680ZP, DoC Product (Supplied by Intertek)
9. Genius Modem, Model: GM56EX, S/N: ZT5505000355, DoC Product (Supplied by Intertek)

*Confirmed by:*

*Leung Wai Leung, Tommy  
Senior Manager  
Intertek Testing Services Hong Kong Ltd.  
Agent for Giant Electronics Ltd.*



\_\_\_\_\_  
Signature

\_\_\_\_\_  
January 16, 2009 Date

**INTERTEK TESTING SERVICES**

---

**EXHIBIT 3**

**RF POWER OUTPUT**

---

## INTERTEK TESTING SERVICES

---

### 3.0 **RF Power Output (Section 2.1046(a), 95.639(d))**

#### A. Equipment Used

<b>Equipment</b>	<b>Brand Name</b>	<b>Model No.</b>
Log Periodic Antenna	EMCO	3148
Test receiver	Rohde & Schwarz	ESVS30
Tuned Dipole Antenna	CDI	A100
Signal Generator	IFR	2023B

#### B. Testing Procedure

1. On a test site, the EUT shall be placed at 1.5m height on a wooden turntable, and in the position closest to normal use as declared by the applicant.
2. The test antenna shall be oriented initially for vertical polarisation located 3m from EUT to correspond to the frequency of the transmitter.
3. The output of the test antenna shall be connected to the measuring receiver and the peak detector is used for the measurement.
4. The transmitter shall be switched on, if possible, without modulation and the measuring receiver shall be tuned to the frequency of the transmitter under test.
5. The test antenna shall be raised and lowered through the specified range of height until a maximum signal level is detected by the measuring receiver.

## **INTERTEK TESTING SERVICES**

---

6. The transmitter shall then be rotated through 360° in the horizontal plane, until the maximum signal level is detected by the measuring receiver.
7. The test antenna shall be raised and lowered again through the specified range of height until a maximum signal level is detected by the measuring receiver.
8. The maximum signal level detected by the measuring receiver shall be noted.
9. The transmitter shall be replaced by a tuned dipole (substitution antenna).
10. The substitution antenna shall be orientated for vertical polarisation and the length of the substitution antenna shall be adjusted to correspond to the frequency of the transmitter.
11. The substitution antenna shall be connected to a calibrated signal generator.
12. If necessary, the input attenuator setting of the measuring receiver shall be adjusted in order to increase the sensitivity of the measuring receiver.
13. The test antenna shall be raised and lowered through the specified range of height to ensure that the maximum signal is received.
14. The input signal to the substitution antenna shall be adjusted to the level that produces a level detected by the measuring receiver, that is equal to the level noted while the transmitter radiated power was measured, corrected for the change of input attenuator setting of the measuring receiver.
15. The input level to the substitution antenna shall be recorded as power level in dBm, corrected for any change of input attenuator setting of the measuring receiver.
16. The measurement shall be repeated with the test antenna and the substitution antenna orientated for horizontal polarisation.
17. The measure of the effective radiated power is the larger of the two levels recorded, at the input to the substitution antenna, corrected for gain of the substitution antenna if necessary.

---

---

## INTERTEK TESTING SERVICES

---

---

**Table 1**

**Giant Electronics Ltd.  
MH230**

**Transmission Power**

Channel	Frequency (MHz)	Effective Radiated Power		FCC 95.639 Limit (W)	Margin (W)	RSS-210 Limit (W)	Margin (W)
		(dBm)	(W)				
1	462.5625	30.2	1.05	5.0	-3.95	2.0	-0.95
2	462.5875	30.2	1.05	5.0	-3.95	2.0	-0.95
3	462.6125	30.2	1.05	5.0	-3.95	2.0	-0.95
4	462.6375	30.2	1.05	5.0	-3.95	2.0	-0.95
5	462.6625	30.2	1.05	5.0	-3.95	2.0	-0.95
6	462.6875	30.2	1.05	5.0	-3.95	2.0	-0.95
7	462.7125	30.2	1.05	5.0	-3.95	2.0	-0.95
8	467.5625	25.4	0.35	0.5	-0.15	0.5	-0.15
9	467.5875	25.4	0.35	0.5	-0.15	0.5	-0.15
10	467.6125	25.4	0.35	0.5	-0.15	0.5	-0.15
11	467.6375	25.4	0.35	0.5	-0.15	0.5	-0.15
12	467.6625	25.4	0.35	0.5	-0.15	0.5	-0.15
13	467.6875	25.4	0.35	0.5	-0.15	0.5	-0.15
14	467.7125	25.4	0.35	0.5	-0.15	0.5	-0.15
15	462.5500	30.2	1.05	5.0	-3.95	2.0	-0.95
16	462.5750	30.2	1.05	5.0	-3.95	2.0	-0.95
17	462.6000	30.2	1.05	5.0	-3.95	2.0	-0.95
18	462.6250	30.2	1.05	5.0	-3.95	2.0	-0.95
19	462.6500	30.2	1.05	5.0	-3.95	2.0	-0.95
20	462.6750	30.2	1.05	5.0	-3.95	2.0	-0.95
21	462.7000	30.2	1.05	5.0	-3.95	2.0	-0.95
22	462.7250	30.2	1.05	5.0	-3.95	2.0	-0.95

Notes: Negative sign in the margin column shows the value below limits.

Verdict: Passed

Test Engineer: Ken Sit

Date of Test: December 15-28, 2008

**INTERTEK TESTING SERVICES**

---

**EXHIBIT 4**

**MODULATION CHARACTERISTICS**



## **INTERTEK TESTING SERVICES**

---

### **4.0 Modulation Characteristics (Section 2.1047(a)(b), 95.637(a))**

In order to satisfy the 95.637(a) and 2.1047(b) requirements, Modulation Frequency Response and Modulation Limiting Characteristics are attached in Exhibit 4.1 & 4.2.

In order to satisfy the 2.1047(a) requirement, Audio Low Pass Filter Response is attached in Exhibit 4.3.

For electronic filing, the modulation frequency response curve and modulation limiting characteristic curve are saved with filename: mfr.pdf and mlc.pdf respectively.

For electronic filing, the audio low pass frequency response curve is saved with filename: lpf.pdf.

## INTERTEK TESTING SERVICES

---

### 4.1 Modulation Frequency Response (Section 2.1047(a), 95.637(a))

#### A. Test Equipment

Equipment	Brand Name	Model No.
Audio Signal Generator	HP	HP8904A
AC Millivoltmeter	Leader	LMV-182A
20 dB RF Attenuator	Bird	8304-200-N
Radiocommunication Service Monitor	R&S	CMS54

#### B. Testing Procedure

- 1) Set-up the test equipment in the following configuration:

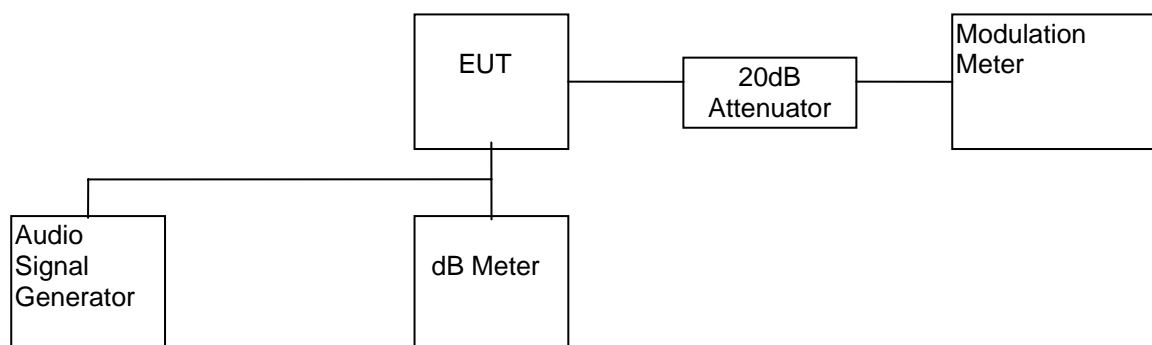

- 2) Set the audio signal generator frequency to the sound pressure level 107dB SPL at the microphone of the EUT.
- 3) The frequency of the audio signal generator is changed from 100Hz to 5kHz.
- 4) Record the frequency deviation.
- 5) The peak frequency deviation must not exceed:

GMRS + FRS :  $\pm 2.5$  kHz

---

---

## INTERTEK TESTING SERVICES

---

---

### C. Test Result

Table 2

**Giant Electronics Ltd.  
MH230**

### Modulation Frequency Response

Test Channel : 4  
Input level = 107dBSPL

Modulation Frequency (Hz)	Modulation index
100	1.28
200	2.16
300	0.43
400	1.08
500	1.11
600	1.34
700	1.55
800	1.50
900	1.76
1000	2.02
1250	1.63
1500	1.35
1750	1.14
2000	0.94
2250	0.74
2500	0.48
2750	0.35
3000	0.30
3125	0.30
3250	0.27
3500	0.22
4000	0.13
5000	0.03

Verdict: Passed

Test Engineer: Ken Sit

Date of Test: December 15-28, 2008

---

## INTERTEK TESTING SERVICES

---

### 4.2 Modulation Limiting Characteristics (Section 2.1047(b), 95.637(a))

#### A. Test Equipment

Equipment	Brand Name	Model No.
Audio Signal Generator	HP	HP8904A
20 dB RF Attenuator	Bird	8304-200-N
Radiocommunication Service Monitor	R&S	CMS54

#### B. Testing Procedure

- 1) Set-up the test equipment in the following configuration:

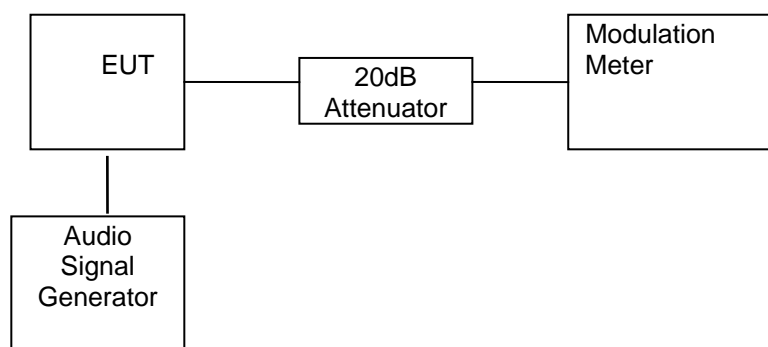

- 2) Set the frequency of the audio signal generator to 500Hz and adjust the level from 47dB SPL to 137dB SPL.
- 3) Record the maximum value of plus or minus peak frequency deviation.
- 4) Repeat the above procedure with frequency 1000Hz, 2500Hz & 3125Hz.
- 5) The peak frequency deviation must not exceed:

GMRS + FRS :  $\pm 2.5\text{kHz}$

---

---

## INTERTEK TESTING SERVICES

---

---

### C. Test Result

**Table 3**

**Giant Electronics Ltd.  
MH230**

### Modulation Limiting Characteristics

Test Channel : 4

<b>Modulation Input (dB SPL)</b>	<b>Peak Frequency Deviation (kHz) at 500Hz</b>	<b>Peak Frequency Deviation (kHz) at 1000Hz</b>	<b>Peak Frequency Deviation (kHz) at 2500Hz</b>	<b>Peak Frequency Deviation (kHz) at 3125Hz</b>
47	0.028	0.030	0.030	0.029
57	0.028	0.033	0.030	0.030
67	0.028	0.033	0.031	0.030
77	0.030	0.056	0.039	0.037
87	0.046	0.151	0.087	0.078
97	0.113	0.730	0.456	0.396
107	0.557	2.017	1.203	0.932
117	1.631	1.967	1.502	0.976
127	2.144	1.960	1.527	0.991
137	2.147	1.973	1.524	1.007

Verdict: Passed

Test Engineer: Ken Sit

Date of Test: December 15-28, 2008

---

## INTERTEK TESTING SERVICES

---

### 4.3 Audio Low Pass Filter Response (Section 2.1047(a))

#### A. Test Equipment

Equipment	Brand Name	Model No.
Audio Signal Generator	HP	HP8904A
AC Millivoltmeter	Leader	LMV-182A

#### B. Testing Procedure

- 1) Connect the audio signal generator to the input of the post limiter low pass filter and the dB meter to the output of the post limiter low pass filter.
- 2) Apply a 1000 Hz tone from the audio signal generator and adjust the level per manufacturer's specifications. Record the dB level of the 1000 Hz tone as  $LEV_{REF}$ .
- 3) Set the audio signal generator to the desired test frequency between 3000 Hz and the upper low pass filter limit. Record the dB level at the test frequency as  $LEV_{FREQ}$ .
- 4) Calculate the audio frequency response at the test frequency as:

$$\text{low pass filter response} = LEV_{FREQ} - LEV_{REF}$$

- 5) Repeat the above procedure for all the desired test frequencies.

---

---

## INTERTEK TESTING SERVICES

---

---

### C. Test Result

**Table 4**

**Giant Electronics Ltd.  
MH230**

#### Low-Pass Filter Response

Test Channel : 4

Audio Input Strength = 400mVrms

Frequency (kHz)	dB relative to 1 kHz	TIA/EIA-603C
1	0.0	0.0
3	-8.5	0.0
4	-15.0	-7.5
5	-20.0	-13.3
6	-24.0	-18.1
8	-31.0	-25.6
10	-36.0	-31.4
15	-46.0	-41.9
20	-52.5	-50.0
30	-56.0	-50.0
40	-56.0	-50.0
50	-56.0	-50.0
60	-56.0	-50.0
70	-56.0	-50.0
80	-56.0	-50.0
90	-56.0	-50.0
100	-56.0	-50.0

Audio Output at 1kHz: -7.0dBV

Verdict: Passed

Test Engineer: Ken Sit

Date of Test: December 15-28, 2008

**INTERTEK TESTING SERVICES**

---

**EXHIBIT 5**

**OCCUPIED BANDWIDTH**



---

## INTERTEK TESTING SERVICES

---

### 5.0 Occupied Bandwidth (Section 95.633(c))

#### A. Test Equipment

Equipment	Brand Name	Model No.
Audio Signal Generator	HP	HP8904A
AC Millivoltmeter	Leader	LMV-182A
20 dB RF Attenuator	Bird	8304-200-N
Spectrum Analyzer	HP	8951EM

#### B. Testing Procedure

- 1) Set-up the test equipment in the following configuration:

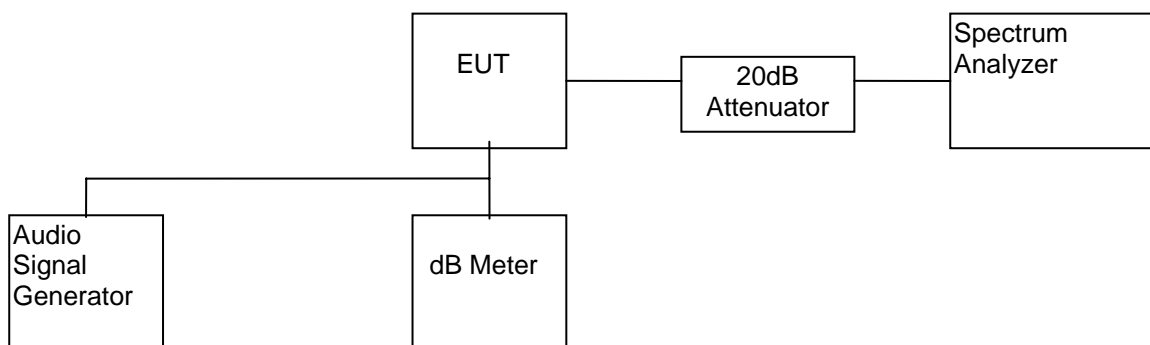

- 2) Set the level of audio signal generator to obtain 16 dB greater than required for 50% modulation.
- 3) The occupied bandwidth is measured with the spectrum analyzer set at 2kHz/div scan and 10dB/div.

---

---

**INTERTEK TESTING SERVICES**

---

---

**C. Test Result**

**Table 5**

**Giant Electronics Ltd.  
MH230**

<b>System</b>	<b>Channel</b>	<b>Measured Bandwidth (kHz)</b>	<b>Limit (kHz)</b>
GMRS	4	5.60	≤20
FRS	11	5.60	≤12.5

Verdict: Passed

For the electronic filing, the bandwidth plot is saved with filename: bw.pdf

Test Engineer: Ken Sit

Date of Test: December 15-28, 2008

**INTERTEK TESTING SERVICES**

---

**EXHIBIT 6**

**SPURIOUS EMISSION**

## INTERTEK TESTING SERVICES

---

### 6.0 **Spurious Emission)**

In order to satisfy the 95.635(b) requirement, the spurious emission from the EUT are measured and shown in the Exhibit 6.1.

---

## INTERTEK TESTING SERVICES

---

### 6.1 Field Strength of Spurious Radiation (Section 2.1053, 95.635(b))

#### A. Test Equipment

<b>Equipment</b>	<b>Brand Name</b>	<b>Model No.</b>
Antenna	EMCO	A100, 3148, 3104C, 3115
Spectrum Analyzer	ADVANTEST	U3661
Test receiver	Rohde & Schwarz	ESVS30
RF Filter	Trilithic	3VF500/1000-5-50-CC
Signal Generator	IFR	2023B

#### B. Testing Procedure

Radiated emission measurements were performed according to the procedures in ANSI C63.4(2003). All measurements were performed in Open Area Test Sites located at Roof Top of Garment Centre, 576 Castle Peak Road, Kowloon, Hong Kong.

## INTERTEK TESTING SERVICES

---

### C. Radiated Emission Configuration Photograph

#### Worst Case Radiated Emission

For electronic filing, the radiated emission configurations photograph is saved with filename: config photos.pdf

---

## INTERTEK TESTING SERVICES

---

### C. Test Result

**Giant Electronics Ltd.  
MH230**

**Table 6(a)**

- 1) Unwanted emission from CARRIER  $\pm 6.25\text{kHz}$  to CARRIER  $\pm 31.25\text{kHz}$   
(Refer to the plots which is saved with filename: spurious.pdf)

Region	Unwanted emission	
	Channel 4	Channel 11
CARRIER $\pm 6.25\text{kHz}$ to $\pm 12.5\text{kHz}$	<25dB	<25dB
CARRIER $\pm 12.5\text{kHz}$ to $\pm 31.25\text{kHz}$	<35dB	<35dB

## INTERTEK TESTING SERVICES

---

**Table 6(b): Channel 4 – Mode: Transmitter without Headset**

Frequency (MHz)	Effective Radiated Power (dBm)	Transmission Power (dBm)	Attenuation (dBc)	Limit (dBc)	Margin (dB)
231.319	-47.5	30.2	77.7	43.2	-34.5
693.956	-45.0	30.2	75.2	43.2	-32.0
925.274	-38.8	30.2	69.0	43.2	-25.8
1156.593	-41.5	30.2	71.7	43.2	-28.5
1387.911	-34.5	30.2	64.7	43.2	-21.5
1619.230	-37.8	30.2	68.0	43.2	-24.8
1850.548	-27.8	30.2	58.0	43.2	-14.8
2081.867	-39.2	30.2	69.4	43.2	-26.2
2313.185	-34.0	30.2	64.2	43.2	-21.0
2544.504	-39.0	30.2	69.2	43.2	-26.0
2775.822	-33.8	30.2	64.0	43.2	-20.8
3007.141	-37.8	30.2	68.0	43.2	-24.8
3238.459	-33.5	30.2	63.7	43.2	-20.5
3469.778	-37.2	30.2	67.4	43.2	-24.2
3701.096	-37.0	30.2	67.2	43.2	-24.0
3932.415	-35.6	30.2	65.8	43.2	-22.6
4163.733	-35.3	30.2	65.5	43.2	-22.3
4395.052	-37.8	30.2	68.0	43.2	-24.8
4626.370	-40.2	30.2	70.4	43.2	-27.2

- Remark: 1. Transmission power is 30.2 dBm or 0.2 dB(W).
2. According to Section 95.635(b7), the unwanted emission should be attenuated below TP by at least  $43 + 10 \log_{10} (TP)$  dB or 43.2 dB.
3. The test is performed according to ANSI/TIA-603-C-2004.

Verdict: Passed

Test Engineer: Ken Sit

Date of Test: December 15-28, 2008



## INTERTEK TESTING SERVICES

---

**Table 6(c): Channel 4 – Mode: Transmitter with USB Adaptor**

Frequency (MHz)	Effective Radiated Power (dBm)	Transmission Power (dBm)	Attenuation (dBc)	Limit (dBc)	Margin (dB)
231.319	-42.2	27.4	69.6	40.4	-29.2
693.956	-37.8	27.4	65.2	40.4	-24.8
925.274	-28.0	27.4	55.4	40.4	-15.0
1156.593	-37.2	27.4	64.6	40.4	-24.2
1387.911	-29.8	27.4	57.2	40.4	-16.8
1619.230	-38.0	27.4	65.4	40.4	-25.0
1850.548	-21.8	27.4	49.2	40.4	-8.8
2081.867	-37.2	27.4	64.6	40.4	-24.2
2313.185	-27.8	27.4	55.2	40.4	-14.8
2544.504	-37.4	27.4	64.8	40.4	-24.4
2775.822	-34.0	27.4	61.4	40.4	-21.0
3007.141	-37.8	27.4	65.2	40.4	-24.8
3238.459	-38.2	27.4	65.6	40.4	-25.2
3469.778	-39.0	27.4	66.4	40.4	-26.0
3701.096	-41.2	27.4	68.6	40.4	-28.2
3932.415	-39.6	27.4	67.0	40.4	-26.6
4163.733	-37.8	27.4	65.2	40.4	-24.8
4395.052	-39.2	27.4	66.6	40.4	-26.2
4626.370	-42.0	27.4	69.4	40.4	-29.0

- Remark: 1. Transmission power is 27.4 dBm or -2.6 dB(W).
2. According to Section 95.635(b7), the unwanted emission should be attenuated below TP by at least  $43 + 10 \log_{10} (TP)$  dB or 40.4 dB.
3. The test is performed according to ANSI/TIA-603-C-2004.

Verdict: Passed

Test Engineer: Ken Sit

Date of Test: December 15-28, 2008

---

---

## INTERTEK TESTING SERVICES

---

---

**Table 6(d): Channel 4**

**Mode: Transmitter with Charing using USB cable via Computer**

<b>Frequency (MHz)</b>	<b>Effective Radiated Power (dBm)</b>	<b>Transmission Power (dBm)</b>	<b>Attenuation (dBc)</b>	<b>Limit (dBc)</b>	<b>Margin (dB)</b>
231.319	-42.8	27.4	70.2	40.4	-29.8
693.596	-38.0	27.4	65.4	40.4	-25.0
925.274	-28.2	27.4	55.6	40.4	-15.2
1156.593	-37.3	27.4	64.7	40.4	-24.3
1387.911	-30.0	27.4	57.4	40.4	-17.0
1619.230	-38.0	27.4	65.4	40.4	-25.0
1850.548	-22.2	27.4	49.6	40.4	-9.2
2081.867	-36.8	27.4	64.2	40.4	-23.8
2313.185	-27.8	27.4	55.2	40.4	-14.8
2544.504	-37.4	27.4	64.8	40.4	-24.4
2775.822	-33.9	27.4	61.3	40.4	-20.9
3007.141	-37.2	27.4	64.6	40.4	-24.2
3238.459	-37.8	27.4	65.2	40.4	-24.8
3469.778	-38.0	27.4	65.4	40.4	-25.0
3701.096	-40.6	27.4	68.0	40.4	-27.6
3932.415	-39.8	27.4	67.2	40.4	-26.8
4163.733	-38.0	27.4	65.4	40.4	-25.0
4395.052	-38.8	27.4	66.2	40.4	-25.8
4626.370	-42.2	27.4	69.6	40.4	-29.2

- Remark: 1. Transmission power is 27.4 dBm or -2.6 dB(W).
2. According to Section 95.635(b7), the unwanted emission should be attenuated below TP by at least  $43 + 10 \log_{10}(TP)$  dB or 40.4 dB.
3. The test is performed according to ANSI/TIA-603-C-2004.

Verdict: Passed

Test Engineer: Ken Sit

Date of Test: December 15-28, 2008

---

---

## INTERTEK TESTING SERVICES

---

---

**Table 6(e): Channel 11 - Mode: Transmitter with Extra Charger**

<b>Frequency (MHz)</b>	<b>Effective Radiated Power (dBm)</b>	<b>Transmission Power (dBm)</b>	<b>Attenuation (dBc)</b>	<b>Limit (dBc)</b>	<b>Margin (dB)</b>
233.819	-47.8	20.5	68.3	33.5	-34.8
701.456	-42.0	20.5	62.5	33.5	-29.0
935.274	-17.8	20.5	38.3	33.5	-4.8
1169.093	-42.0	20.5	62.5	33.5	-29.0
1402.911	-13.4	20.5	33.9	33.5	-0.4
1636.730	-40.5	20.5	61.0	33.5	-27.5
1870.548	-33.5	20.5	54.0	33.5	-20.5
2104.367	-41.5	20.5	62.0	33.5	-28.5
2338.185	-34.8	20.5	55.3	33.5	-21.8
2572.004	-38.8	20.5	59.3	33.5	-25.8
2805.822	-36.5	20.5	57.0	33.5	-23.5
3039.641	-38.2	20.5	58.7	33.5	-25.2
3273.459	-37.0	20.5	57.5	33.5	-24.0
3507.278	-42.0	20.5	62.5	33.5	-29.0
3741.096	-40.5	20.5	61.0	33.5	-27.5
3974.915	-41.2	20.5	61.7	33.5	-28.2
4208.733	-41.5	20.5	62.0	33.5	-28.5
4442.552	-39.0	20.5	59.5	33.5	-26.0
4676.370	-37.2	20.5	57.7	33.5	-24.2

- Remark: 1. Transmission power is 20.5 dBm or -9.5 dB(W).
2. According to Section 95.635(b7), the unwanted emission should be attenuated below TP by at least  $43 + 10 \log_{10} (TP)$  dB or 33.5 dB
3. The test is performed according to ANSI/TIA-603-C-2004.

Verdict: Passed

Test Engineer: Ken Sit

Date of Test: December 15-28, 2008

## INTERTEK TESTING SERVICES

---

### 6.2 Field Strength of Radiated Emission and AC line Conducted Emission (Section 15.109 & 15.107) - Weather Band Receiver

Data is included worst case configuration (the configuration which resulted in the highest emission levels). A sample calculation, configuration photographs and data tables of the emissions are included.

## INTERTEK TESTING SERVICES

---

### A. Field Strength Calculation

The field strength is calculated by adding the reading on the Spectrum Analyzer to the factors associated with preamplifiers (if any), antennas, cables, pulse desensitization and average factors (when specified limit is in average and measurements are made with peak detectors). A sample calculation is included below.

$$FS = RA + AF + CF - AG + PD + AV$$

where

- FS = Field Strength in dB $\mu$ V/m
- RA = Receiver Amplitude (including preamplifier) in dB $\mu$ V
- CF = Cable Attenuation Factor in dB
- AF = Antenna Factor in dB
- AG = Amplifier Gain in dB
- PD = Pulse Desensitization in dB
- AV = Average Factor in -dB

In the radiated emission table which follows, the reading shown on the data table may reflect the preamplifier gain. An example of the calculations, where the reading does not reflect the preamplifier gain, follows:

$$FS = RA + AF + CF - AG + PD + AV$$

## INTERTEK TESTING SERVICES

---

### A. Field Strength Calculation (cont'd)

#### Example

Assume a receiver reading of 62.0 dB $\mu$ V is obtained. The antenna factor of 7.4 dB and cable factor of 1.6 dB is added. The amplifier gain of 29 dB is subtracted. The pulse desensitization factor of the spectrum analyzer was 0 dB, and the resultant average factor was -10 dB. The net field strength for comparison to the appropriate emission limit is 32 dB $\mu$ V/m. This value in dB $\mu$ V/m was converted to its corresponding level in  $\mu$ V/m.

$$RA = 62.0 \text{ dB}\mu\text{V}$$

$$AF = 7.4 \text{ dB}$$

$$CF = 1.6 \text{ dB}$$

$$AG = 29.0 \text{ dB}$$

$$PD = 0 \text{ dB}$$

$$AV = -10 \text{ dB}$$

$$FS = 62 + 7.4 + 1.6 - 29 + 0 + (-10) = 32 \text{ dB}\mu\text{V/m}$$

$$\text{Level in } \mu\text{V/m} = \text{Common Antilogarithm} [(32 \text{ dB}\mu\text{V/m})/20] = 39.8 \mu\text{V/m}$$

## INTERTEK TESTING SERVICES

---

### **B. Radiated Emission Configuration Photograph - Weather Band Receiver**

Worst Case Radiated Emission  
at  
562.400 MHz

For electronic filing, the worst case radiated emission configuration photograph is saved with filename: config photos.pdf

## INTERTEK TESTING SERVICES

---

### C. Radiated Emission Data - Weather Band Receiver

The data on the following page lists the significant emission frequencies, the limit and the margin of compliance. Numbers with a minus sign are below the limit.

Judgement: Passed by 12.0 dB margin

#### **TEST PERSONNEL:**



---

*Signature*

Ken Sit, Assistant Manager

*Typed/Printed Name*

January 16, 2009

*Date*



---

## INTERTEK TESTING SERVICES

---

Company: Giant Electronics Ltd.  
Model: MH230  
Mode: Weather Band Receiver

Date of Test: December 15-28, 2008

Table 4(f)

### Radiated Emissions

Polarization	Frequency (MHz)	Reading (dB $\mu$ V)	Pre-amp (dB)	Antenna Factor (dB)	Net at 3m (dB $\mu$ V/m)	Limit at 3m (dB $\mu$ V/m)	Margin (dB)
H	140.600	33.4	16	14.0	31.4	43.5	-12.1
H	281.200	24.0	16	22.0	30.0	46.0	-16.0
H	421.800	24.3	16	25.0	33.3	46.0	-12.7
H	562.400	22.0	16	28.0	34.0	46.0	-12.0
H	703.000	18.8	16	30.0	32.8	46.0	-13.2

- NOTES: 1. Peak detector is used for the emission measurement.
2. All measurements were made at 3 meters.
3. Negative value in the margin column shows emission below limit.

Test Engineer: Ken Sit

## INTERTEK TESTING SERVICES

---

### D. Conducted Emission Configuration Photograph

Worst Case Conducted Emission

For electronic filing, the conducted emission configurations photograph is saved with filename: config photos.pdf

## INTERTEK TESTING SERVICES

---

### D. Test Result

**Giant Electronics Ltd.  
MH230**

**Conducted Emission**

For electronic filing, the conducted emission test result is saved with filename:  
conduct.pdf

**INTERTEK TESTING SERVICES**

---

**EXHIBIT 7**

**FREQUENCY STABILITY**

## INTERTEK TESTING SERVICES

---

### 7.0 Frequency Stability (Section 2.1055(a)(b)(d), 95.627(b))

The frequency tolerance was tested in normal condition & over extreme ambient conditions with respect to voltage and temperature variation.

---

## INTERTEK TESTING SERVICES

---

### 7.1 Frequency Tolerance (Section 95.627(b))

#### A. Test Equipment

Equipment	Brand Name	Model No.
20 dB RF Attenuator	Bird	8304-200-N
Frequency Counter	OPTOELECTRONICS	3000A

#### B. Testing Procedure

- 1) Set-up the test equipment in the following configuration:

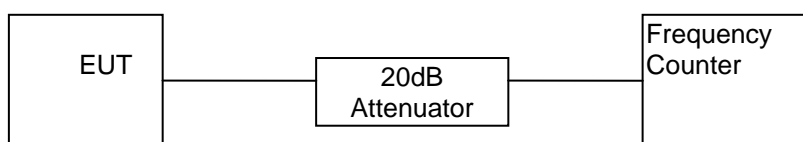

- 2) Measure all transmit channel frequencies in MHz.

---

---

**INTERTEK TESTING SERVICES**

---

---

**C. Test Result**

**Table 7**

**Giant Electronics Ltd.  
MH230**

**Frequency Tolerance**

Channel	Frequency (MHz)	Measured Frequency (MHz)	Tolerance (%)
1	462.5625	462.56275	0.000054
2	462.5875	462.58775	0.000054
3	462.6125	462.61275	0.000054
4	462.6375	462.63775	0.000054
5	462.6625	462.66275	0.000054
6	462.6875	462.68775	0.000054
7	462.7125	462.71275	0.000054
8	467.5625	467.56275	0.000053
9	467.5875	467.58775	0.000053
10	467.6125	467.61275	0.000053
11	467.6375	467.63775	0.000053
12	467.6625	467.66275	0.000053
13	467.6875	467.68775	0.000053
14	467.7125	467.71275	0.000053
15	462.5500	462.55025	0.000054
16	462.5750	462.57525	0.000054
17	462.6000	462.60025	0.000054
18	462.6250	462.62525	0.000054
19	462.6500	462.65025	0.000054
20	462.6750	462.67525	0.000054
21	462.7000	462.70025	0.000054
22	462.7250	462.72525	0.000054

FCC Limit for FRS (95.627(b)):  $\leq \pm 0.00025\%$

RSS-210 Limit for GMRS and FRS (A6.2.6, A6.1.6):  $< \pm 5\text{ppm}$

Verdict: Passed

Test Engineer: Ken Sit

Date of Test: December 15-28, 2008

---

## INTERTEK TESTING SERVICES

---

### 7.2 Frequency Stability - Temperature (Section 2.1055(a)(b), 95.627(b))

#### A. Test Equipment

Equipment	Brand Name	Model No.
20 dB RF Attenuator	Bird	8304-200-N
Frequency Counter	OPTOELECTRONICS	3000A

#### B. Testing Procedure

- 1) Set-up the test equipment in the following configuration:

Temperature Chamber

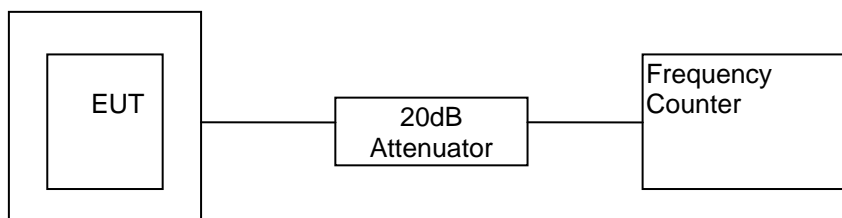

- 2) Set the Temperature Chamber to 20°C and stabilize the EUT temperature for one hour. Set transmitter ON for two minutes.
- 3) Measure the channel frequency of channel 4, 11 in MHz.
- 4) Turn the EUT OFF.
- 5) Repeat the above procedure from -30°C to 50°C with 10°C increment for GMRS.
- 6) Repeat the above procedure from -20°C to 50°C with 10°C increment for FRS.



---

---

## INTERTEK TESTING SERVICES

---

---

### C. Test Result

**Table 8(a)**

**Giant Electronics Ltd.  
MH230**

### Frequency Deviation with Temperature Variation

Channel : 4

Temperature (°C)	Assigned Frequency (MHz)	Measured Frequency (MHz)	Deviation (%)	*Frequency Tolerance with reference to its value at +20°C (ppm)
-30	462.63750	462.63618	-0.000285	-3.4
-20	462.63750	462.63698	-0.000112	-1.7
-10	462.63750	462.63763	0.000028	-0.3
0	462.63750	462.63804	0.000117	-0.6
10	462.63750	462.63802	0.000112	0.6
20	462.63750	462.63775	0.000054	0.0
30	462.63750	462.63769	0.000041	-0.1
40	462.63750	462.63762	0.000026	-0.3
50	462.63750	462.63815	0.000140	-0.9

Remark: 1) For GMRS, frequency tolerance must be maintained within a frequency tolerance of 0.0005%.

2) \*This column is presentable for Industry Canada Certification only.

Verdict: Passed

Test Engineer: Ken Sit

Date of Test: December 15-28, 2008

---

---

**INTERTEK TESTING SERVICES**

---

---

**C. Test Result**

**Table 8(b)**

**Giant Electronics Ltd.  
MH230**

**Frequency Deviation with Temperature Variation**

Channel : 11

Temperature (°C)	Assigned Frequency (MHz)	Measured Frequency (MHz)	Deviation (%)	*Frequency Tolerance with reference to its value at +20°C (ppm)
-20	467.63750	467.63699	-0.000109	-1.6
-10	467.63750	467.63764	0.000030	-0.2
0	467.63750	467.63803	0.000113	0.6
10	467.63750	467.63801	0.000109	0.6
20	467.63750	467.63775	0.000053	0.0
30	467.63750	467.63768	0.000038	-0.1
40	467.63750	467.63761	0.000024	-0.3
50	467.63750	467.63814	0.000137	0.8

Remark: 1) For GMRS, frequency tolerance must be maintained within a frequency tolerance of 0.0005%.

2) \*This column is presentable for Industry Canada Certification only.

Verdict: Passed

Test Engineer: Ken Sit

Date of Test: December 15-28, 2008

---

## INTERTEK TESTING SERVICES

---

### 7.3 Frequency Stability - Voltage (Section 2.1055(d), 95.627(b))

#### A. Test Equipment

Equipment	Brand Name	Model No.
Regulated Power Supply	PAD	30-35L
20 dB RF Attenuator	Bird	8304-200-N
Voltage meter	Fluke	87
Frequency Counter	OPTOELECTRONICS	3000A

#### B. Testing Procedure

- 1) Set-up the test equipment in the following configuration:

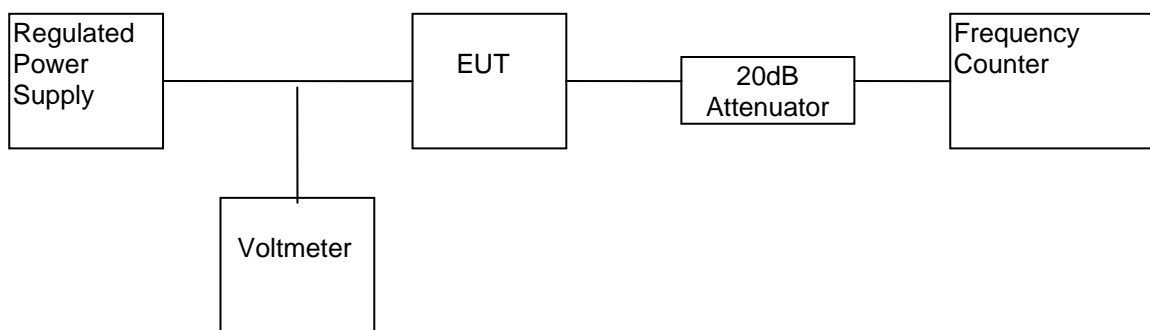

- 2) Vary the level of regulated power supply to the manufacturer specified battery end point of the EUT.
- 3) Measure the channel frequency of channel 4 and 11 in MHz.

---

---

## INTERTEK TESTING SERVICES

---

---

### C. Test Result

**Table 9**

**Giant Electronics Ltd.  
MH230**

#### Frequency Deviation with Voltage Variation

The manufacturer specified battery end point 3.6V

Channel	Frequency (MHz)	Measured Frequency (MHz)	Tolerance (%)
4	462.63750	462.63748	-0.000004
11	467.63750	467.63755	0.000011

- Remark: 1) For FRS, frequency tolerance must be maintained within a frequency tolerance of 0.00025%.  
2) For GMRS, frequency tolerance must be maintained within a frequency tolerance of 0.0005%.  
3) The test voltage is from primary supply voltage to 3.6V

Test Engineer: Ken Sit

Date of Test: December 15-28, 2008