



TEST REPORT



BNetzA-CAB-02/21-102

Test report no.: 1-5421_22-01-24_TR1-R1

Testing laboratory

cetecom advanced GmbH
 Untertuerkheimer Strasse 6 – 10
 66117 Saarbruecken / Germany
 Phone: + 49 681 5 98 - 0
 Fax: + 49 681 5 98 - 9075
 Internet: <https://cetecomadvanced.com>
 e-mail: mail@cetecomadvanced.com

Accredited Testing Laboratory:

The testing laboratory (area of testing) is accredited according to DIN EN ISO/IEC 17025 (2018-03) by the Deutsche Akkreditierungsstelle GmbH (DAkkS).
 The accreditation is valid for the scope of testing procedures as stated in the accreditation certificate with the registration number: D-PL-12047-01-00.
 ISED Testing Laboratory Recognized Listing Number: DE0001
 FCC designation number: DE0002

Applicant

EMS Technologies Canada, Ltd.
 400 Maple Grove Road
 K2V 1B8 Ottawa / Canada
 Phone: -/
 Contact: Subhadeep Pal
 e-mail: Subhadeep.Pal@honeywell.com

Manufacturer

HONEYWELL, SPOL. S R.O. Honeywell Aerospace
 Turanka 100/1387
 62700 Brno / CZECH REPUBLIC

Test standard/s

FCC - Title 47 CFR Part 15 FCC - Title 47 of the Code of Federal Regulations; Chapter I; Part 15 - Radio frequency devices

For further applied test standards please refer to section 3 of this test report.

Test Item

Kind of test item: **GEN6 small Satcom indoor unit**
Model name: **GEN6 small Satcom indoor unit**
FCC ID: K6KSATCOM5G
ISED certification number: 1275B-SATCOM5G
Frequency: 5150 MHz – 5350 MHz; 5470 MHz – 5725 MHz; 5725 MHz – 5850 MHz
Technology tested: WLAN
Antenna: Integrated antenna
Power supply: 27.0 V to 30.0 V DC by power supply
Temperature range: -20°C to +55°C

This test report is electronically signed and valid without handwritten signature. For verification of the electronic signatures, the public keys can be requested at the testing laboratory.

Test report authorized:

Marco Bertolino
 Supervisor Radio Services
 Radio Labs

Test performed:

René Oelmann
 Lab Manager
 Radio Labs

1 Table of contents

1	Table of contents.....	2
2	General information	3
2.1	Notes and disclaimer.....	3
2.2	Application details.....	3
2.3	Test laboratories sub-contracted	3
3	Test standard/s, references and accreditations	4
4	Reporting statements of conformity – decision rule	5
5	Test environment.....	6
6	Test item	6
6.1	General description	6
6.2	Additional information.....	6
7	Description of the test setup	7
7.1	Shielded semi anechoic chamber.....	8
7.2	Shielded fully anechoic chamber	9
7.3	Radiated measurements > 18 GHz	10
8	Sequence of testing.....	11
8.1	Sequence of testing radiated spurious 9 kHz to 30 MHz.....	11
8.2	Sequence of testing radiated spurious 30 MHz to 1 GHz	12
8.3	Sequence of testing radiated spurious 1 GHz to 18 GHz	13
8.4	Sequence of testing radiated spurious above 18 GHz	14
9	Measurement uncertainty	15
10	Summary of measurement results	16
11	Additional comments	17
12	Measurement results.....	23
12.1	Band edge compliance radiated.....	23
12.2	Spurious emissions radiated 1 GHz to 40 GHz	26
13	Glossary.....	45
14	Document history	46

2 General information

2.1 Notes and disclaimer

The test results of this test report relate exclusively to the test item specified in this test report. cetecom advanced GmbH does not assume responsibility for any conclusions and generalizations drawn from the test results with regard to other specimens or samples of the type of the equipment represented by the test item.

The test report may only be reproduced or published in full. Reproduction or publication of extracts from the report requires the prior written approval of cetecom advanced GmbH.

The testing service provided by cetecom advanced GmbH has been rendered under the current "General Terms and Conditions for cetecom advanced GmbH".

cetecom advanced GmbH will not be liable for any loss or damage resulting from false, inaccurate, inappropriate or incomplete product information provided by the customer.

Under no circumstances does the cetecom advanced GmbH test report include any endorsement or warranty regarding the functionality, quality or performance of any other product or service provided.

Under no circumstances does the cetecom advanced GmbH test report include or imply any product or service warranties from cetecom advanced GmbH, including, without limitation, any implied warranties of merchantability, fitness for purpose, or non-infringement, all of which are expressly disclaimed by cetecom advanced GmbH.

All rights and remedies regarding vendor's products and services for which cetecom advanced GmbH has prepared this test report shall be provided by the party offering such products or services and not by cetecom advanced GmbH.

In no case this test report can be considered as a Letter of Approval.

This test report is electronically signed and valid without handwritten signature. For verification of the electronic signatures, the public keys can be requested at the testing laboratory.

2.2 Application details

Date of receipt of order: 2023-07-17

Date of receipt of test item: 2023-11-20

Start of test:* 2023-11-20

End of test:* 2024-01-19

Person(s) present during the test: -/-

*Date of each measurement, if not shown in the plot, can be requested. Dates are stored in the measurement software.

2.3 Test laboratories sub-contracted

None

3 Test standard/s, references and accreditations

Test standard	Date	Description
FCC - Title 47 CFR Part 15	-/-	FCC - Title 47 of the Code of Federal Regulations; Chapter I; Part 15 - Radio frequency devices
RSS - 247 Issue 3	August 2023	Digital Transmission Systems (DTSS), Frequency Hopping Systems (FHSs) and Licence - Exempt Local Area Network (LE-LAN) Devices
Guidance	Version	Description
KDB 789033 D02	v02r01	Guidelines for Compliance Testing of Unlicensed National Information Infrastructure (U-NII) Devices - Part 15, Subpart E
ANSI C63.4-2014	-/-	American National Standard for Methods of Measurement of Radio-Noise Emissions from Low-Voltage Electrical and Electronic Equipment in the Range of 9 kHz to 40 GHz
ANSI C63.10-2013	-/-	American National Standard of Procedures for Compliance Testing of Unlicensed Wireless Devices
KDB 996369 D04	v02	MODULAR TRANSMITTER INTEGRATION GUIDE GUIDANCE FOR HOST PRODUCT MANUFACTURERS

4 Reporting statements of conformity – decision rule

Only the measured values related to their corresponding limits will be used to decide whether the equipment under test meets the requirements of the test standards listed in chapter 3. The measurement uncertainty is mentioned in this test report, see chapter 9, but is not taken into account - neither to the limits nor to the measurement results. Measurement results with a smaller margin to the corresponding limits than the measurement uncertainty have a potential risk of more than 5% that the decision might be wrong."

measured value, measurement uncertainty, verdict



5 Test environment

Temperature	:	T_{nom} +22 °C during room temperature tests T_{max} +55 °C during high temperature tests T_{min} -20 °C during low temperature tests
Relative humidity content	:	42 %
Barometric pressure	:	1018 hpa
Power supply	:	V_{nom} 28.0 V DC by power supply V_{max} 30.0 V V_{min} 27.0 V

6 Test item

6.1 General description

Kind of test item	:	GEN6 small Satcom indoor unit
Model name	:	GEN6 small Satcom indoor unit
HMN	:	-/-
PMN	:	Satcom 5G
HVIN	:	Satcom 5G
FVIN	:	-/-
S/N serial number	:	SN15
Hardware status	:	90600736 REV A
Software status	:	90600929 REV A
Firmware status	:	-/-
Frequency band	:	5150 MHz – 5350 MHz; 5470 MHz – 5725 MHz; 5725 MHz – 5850 MHz
Type of radio transmission	:	OFDM
Use of frequency spectrum	:	
Type of modulation	:	(D)BPSK, (D)QPSK, 16 – QAM, 64 – QAM
Number of channels	:	24
Antenna	:	External antenna
Power supply	:	27.0 V to 30.0 V DC by power supply
Temperature range	:	-20°C to +55°C

6.2 Additional information

The content of the following annexes is defined in the QA. It may be that not all of the listed annexes are necessary for this report, thus some values in between may be missing.

Test setup and EUT photos are included in test report:

- 1-5421_22-01-01_AnnexA
- 1-5421_22-01-01_AnnexB
- 1-5421_22-01-01_AnnexC

7 Description of the test setup

Typically, the calibrations of the test apparatus are commissioned to and performed by an accredited calibration laboratory. The calibration intervals are determined in accordance with the DIN EN ISO/IEC 17025. In addition to the external calibrations, the laboratory executes comparison measurements with other calibrated test systems or effective verifications. Weekly chamber inspections and range calibrations are performed. Where possible, RF generating and signaling equipment as well as measuring receivers and analyzers are connected to an external high-precision 10 MHz reference (GPS-based or rubidium frequency standard).

In order to simplify the identification of the equipment used at some special tests, some items of test equipment and ancillaries can be provided with an identifier or number in the equipment list below (Lab/Item).

Each block diagram listed can contain several test setup configurations. All devices belonging to a test setup are identified with the same letter syntax. For example: Column Setup and all devices with an A.

Agenda: Kind of Calibration

k	calibration / calibrated	EK	limited calibration
ne	not required (k, ev, izw, zw not required)	zw	cyclical maintenance (external cyclical maintenance)
ev	periodic self verification	izw	internal cyclical maintenance
Ve	long-term stability recognized	g	blocked for accredited testing
vlk!	Attention: extended calibration interval		
NK!	Attention: not calibrated	*)	next calibration ordered / currently in progress

7.1 Shielded semi anechoic chamber

The radiated measurements are performed in vertical and horizontal plane in the frequency range from 30 MHz to 1 GHz in semi-anechoic chambers. The EUT is positioned on a non-conductive support with a height of 0.80 m above a conductive ground plane that covers the whole chamber. The receiving antennas are conform to specifications ANSI C63. These antennas can be moved over the height range between 1.0 m and 4.0 m in order to search for maximum field strength emitted from EUT. The measurement distances between EUT and receiving antennas are indicated in the test setups for the various frequency ranges. For each measurement, the EUT is rotated in all three axes until the maximum field strength is received. The wanted and unwanted emissions are received by spectrum analyzers where the detector modes and resolution bandwidths over various frequency ranges are set according to requirement ANSI C63.

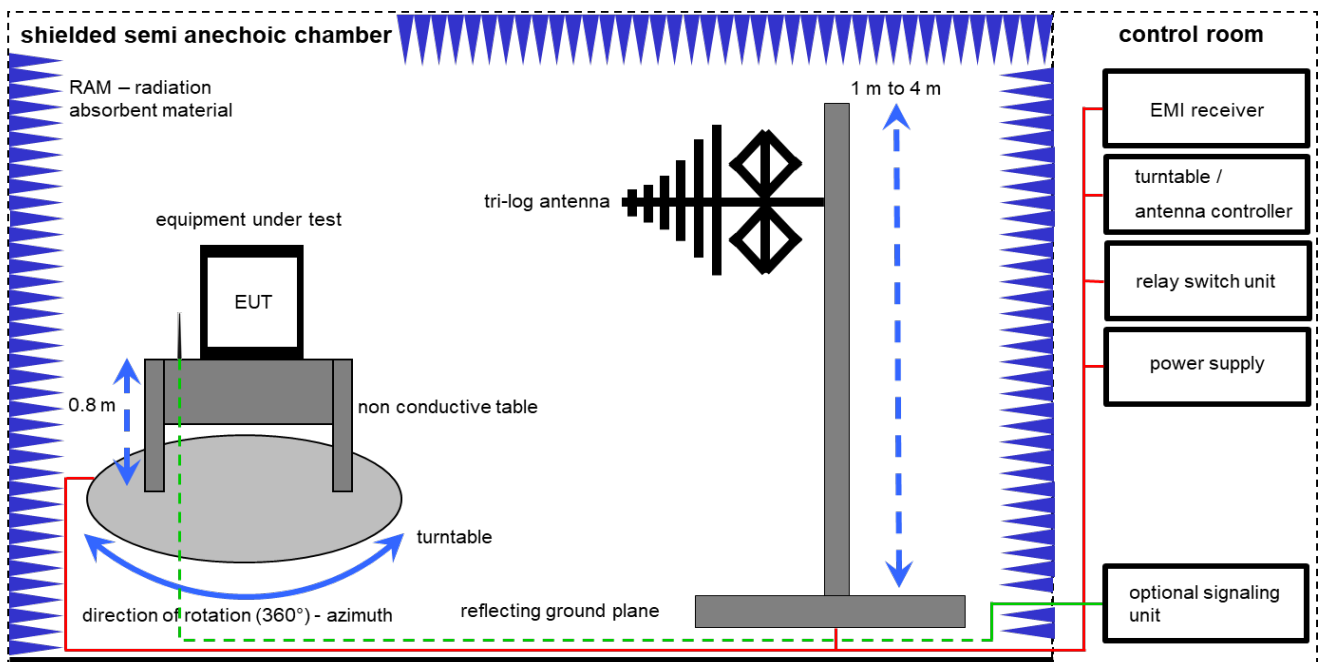

Measurement distance: tri-log antenna 10 meter; EMC32 software version: 10.59.00

$$FS = UR + CL + AF$$

(FS-field strength; UR-voltage at the receiver; CL-loss of the cable; AF-antenna factor)

Example calculation:

$$FS [dB\mu V/m] = 12.35 [dB\mu V/m] + 1.90 [dB] + 16.80 [dB/m] = 31.05 [dB\mu V/m] (35.69 \mu V/m)$$

Equipment table:

No.	Setup	Equipment	Type	Manufacturer	Serial No.	INV. No.	Kind of Calibration	Last Calibration	Next Calibration
1	A	Switch-Unit	3488A	HP	2719A14505	300000368	ev	-/-	-/-
2	A	Semi anechoic chamber	3000023	MWB AG	-/-	300000551	ne	-/-	-/-
3	A	Antenna Tower	Model 2175	ETS-Lindgren	64762	300003745	izw	-/-	-/-
4	A	Positioning Controller	Model 2090	ETS-Lindgren	64672	300003746	izw	-/-	-/-
5	A	Turntable Interface-Box	Model 105637	ETS-Lindgren	44583	300003747	izw	-/-	-/-
6	A	TRILOG Broadband Test-Antenna 30 MHz - 3 GHz	VULB9163	Schwarzbeck Mess - Elektronik	295	300003787	vIK!	23.05.2023	31.05.2025
7	A	Turntable	2089-4.0	EMCO	-/-	300004394	ne	-/-	-/-
8	A	PC	TecLine	F+W	-/-	300004388	ne	-/-	-/-
9	A	EMI Test Receiver	ESR3	Rohde & Schwarz	102587	300005771	k	06.12.2023	31.12.2024

7.2 Shielded fully anechoic chamber

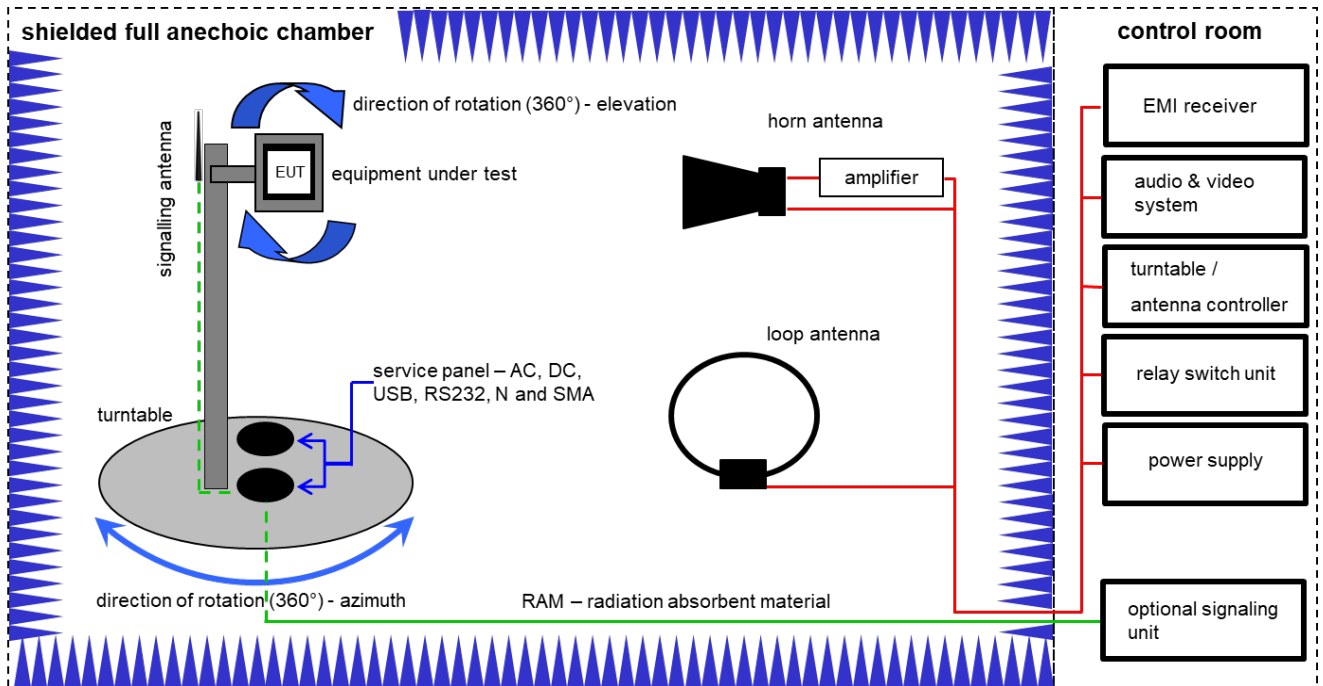

Measurement distance: horn antenna 3 meter; loop antenna 3 meter / 1 meter

FS = UR + CA + AF

(FS-field strength; UR-voltage at the receiver; CA-loss of the signal path; AF-antenna factor)

Example calculation:

FS [dB μ V/m] = 40.0 [dB μ V/m] + (-35.8) [dB] + 32.9 [dB/m] = 37.1 [dB μ V/m] (71.61 μ V/m)

Equipment table:

No.	Setup	Equipment	Type	Manufacturer	Serial No.	INV. No.	Kind of Calibration	Last Calibration	Next Calibration
1	A	Double-Ridged Waveguide Horn Antenna 1-18.0GHz	3115	EMCO	8812-3088	300001032	vKI!	10.10.2023	31.10.2025
2	A	DC power supply, 60Vdc, 50A, 1200 W	6032A	HP	2920A04590	300001041	vKI!	09.12.2020	08.12.2023
3	A	Highpass Filter	WHKX7.0/18G-8SS	Wainwright	18	300003789	ne	-/-	-/-
4	A	Band Reject Filter	WRCG2400/2483-2375/2505-50/10SS	Wainwright	26	300003792	ne	-/-	-/-
5	A	TRILOG Broadband Test-Antenna 30 MHz - 3 GHz	VULB9163	Schwarzbeck Mess-Elektronik	295	300003787	vKI!	23.05.2023	31.05.2025
6	A	Broadband Amplifier 0.5-18 GHz	CBLU5184540	CERNEX	22051	300004483	ev	-/-	-/-
7	A	4U RF Switch Platform	L4491A	Agilent Technologies	MY50000032	300004510	ne	-/-	-/-
8	A	EMI Test Receiver 9kHz-26,5GHz	ESR26	Rohde & Schwarz	101376	300005063	k	13.12.2022	31.12.2023
9	A	Double-Ridged Waveguide Horn Antenna 1-18.0GHz	3115	EMCO	9107-3696	300001604	vKI!	20.03.2023	19.03.2025

7.3 Radiated measurements > 18 GHz

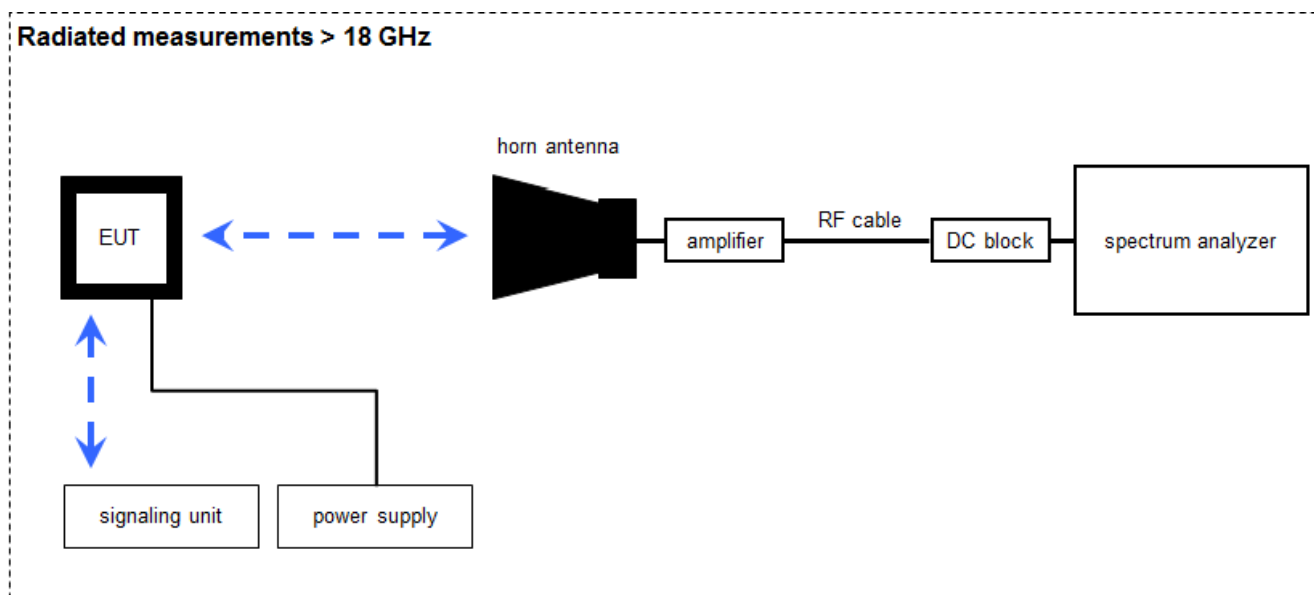

Measurement distance: horn antenna 50 cm

$$FS = UR + CA + AF$$

(FS-field strength; UR-voltage at the receiver; CA-loss signal path & distance correction; AF-antenna factor)

Example calculation:

$$FS [dB\mu V/m] = 40.0 [dB\mu V/m] + (-60.1) [dB] + 36.74 [dB/m] = 16.64 [dB\mu V/m] (6.79 \mu V/m)$$

Equipment table:

No.	Setup	Equipment	Type	Manufacturer	Serial No.	INV. No.	Kind of Calibration	Last Calibration	Next Calibration
1	A	Std. Gain Horn Antenna 26.5-40.0 GHz	V637	Narda	8216	300000510	vKI!	17.01.2022	31.01.2024
2	A	Std. Gain Horn Antenna 18.0-26.5 GHz	638	Narda	01096	300000486	vKI!	17.01.2022	31.01.2024
3	A	Broadband LNA 18-50 GHz	CBL18503070PN	CERNEX	25240	300004948	ev	09.03.2022	08.03.2024
4	A	Signal analyzer	FSV40	Rohde&Schwarz	101042	300004517	k	06.12.2023	31.12.2024
5	A	DC-Blocker 0.1-40 GHz	8141A	Inmet	-/-	400001185	ev	-/-	-/-
6	A	DC Power Supply	HMP2020	Rohde & Schwarz	102850 / 101699	300005517	vKI!	07.12.2023	31.12.2025

8 Sequence of testing

8.1 Sequence of testing radiated spurious 9 kHz to 30 MHz

Setup

- The equipment is set up to simulate normal operation mode as described in the user manual or defined by the manufacturer.
- If the EUT is a tabletop system, it is placed on a table with 0.8 m height.
- If the EUT is a floor standing device, it is placed directly on the turn table.
- Auxiliary equipment and cables are positioned to simulate normal operation conditions as described in ANSI C 63.4.
- The AC power port of the EUT (if available) is connected to a power outlet below the turntable.
- Measurement distance is 3 m (see ANSI C 63.4) – see test details.
- EUT is set into operation.

Premeasurement*

- The turntable rotates from 0° to 315° using 45° steps.
- The antenna height is 1 m.
- At each turntable position the analyzer sweeps with positive-peak detector to find the maximum of all emissions.

Final measurement

- Identified emissions during the pre-measurement are maximized by the software by rotating the turntable from 0° to 360°.
- Loop antenna is rotated about its vertical axis for maximum response at each azimuth about the EUT. (For certain applications, the loop antenna plane may also need to be positioned horizontally at the specified distance from the EUT)
- The final measurement is done in the position (turntable and elevation) causing the highest emissions with quasi-peak (as described in ANSI C 63.4).
- Final levels, frequency, measuring time, bandwidth, turntable position, correction factor, margin to the limit and limit will be recorded. A plot with the graph of the premeasurement and the limit is stored.

*Note: The sequence will be repeated three times with different EUT orientations.

8.2 Sequence of testing radiated spurious 30 MHz to 1 GHz

Setup

- The equipment is set up to simulate normal operation mode as described in the user manual or defined by the manufacturer.
- If the EUT is a tabletop system, a table with 0.8 m height is used, which is placed on the ground plane.
- If the EUT is a floor standing device, it is placed on the ground plane with insulation between both.
- Auxiliary equipment and cables are positioned to simulate normal operation conditions as described in ANSI C 63.4.
- The AC power port of the EUT (if available) is connected to a power outlet below the turntable.
- Measurement distance is 10 m or 3 m (see ANSI C 63.4) – see test details.
- EUT is set into operation.

Premeasurement

- The turntable rotates from 0° to 315° using 45° steps.
- The antenna is polarized vertical and horizontal.
- The antenna height changes from 1 m to 3 m.
- At each turntable position, antenna polarization and height the analyzer sweeps three times in peak to find the maximum of all emissions.

Final measurement

- The final measurement is performed for at least six highest peaks according to the requirements of the ANSI C63.4.
- Based on antenna and turntable positions at which the peak values are measured the software maximize the peaks by changing turntable position $\pm 45^\circ$ and antenna height between 1 and 4 m.
- The final measurement is done with quasi-peak detector (as described in ANSI C 63.4).
- Final levels, frequency, measuring time, bandwidth, antenna height, antenna polarization, turntable angle, correction factor, margin to the limit and limit are recorded. A plot with the graph of the premeasurement with marked maximum final results and the limit is stored.

8.3 Sequence of testing radiated spurious 1 GHz to 18 GHz

Setup

- The equipment is set up to simulate normal operation mode as described in the user manual or defined by the manufacturer.
- If the EUT is a tabletop system, a 2-axis positioner with 1.5 m height is used.
- If the EUT is a floor standing device, it is placed directly on the turn table.
- Auxiliary equipment and cables are positioned to simulate normal operation conditions as described in ANSI C 63.4.
- The AC power port of the EUT (if available) is connected to a power outlet below the turntable.
- Measurement distance is 3 m (see ANSI C 63.4) – see test details.
- EUT is set into operation.

Premeasurement

- The turntable rotates from 0° to 315° using 45° steps.
- The antenna is polarized vertical and horizontal.
- The antenna height is 1.5 m.
- At each turntable position and antenna polarization the analyzer sweeps with positive peak detector to find the maximum of all emissions.

Final measurement

- The final measurement is performed for at least six highest peaks according to the requirements of the ANSI C63.4.
- Based on antenna and turntable positions at which the peak values are measured the software maximizes the peaks by rotating the turntable from 0° to 360°. This measurement is repeated for different EUT-table positions (0° to 150° in 30°-steps) and for both antenna polarizations.
- The final measurement is done in the position (turntable, EUT-table and antenna polarization) causing the highest emissions with Peak and RMS detector (as described in ANSI C 63.4).
- Final levels, frequency, measuring time, bandwidth, turntable position, EUT-table position, antenna polarization, correction factor, margin to the limit and limit are recorded. A plot with the graph of the premeasurement with marked maximum final results and the limit is stored.

8.4 Sequence of testing radiated spurious above 18 GHz

Setup

- The equipment is set up to simulate normal operation mode as described in the user manual or defined by the manufacturer.
- Auxiliary equipment and cables are positioned to simulate normal operation conditions as described in ANSI C 63.4.
- The AC power port of the EUT (if available) is connected to a power outlet.
- The measurement distance is as appropriate (e.g. 0.5 m).
- The EUT is set into operation.

Premeasurement

- The test antenna is handheld and moved carefully over the EUT to cover the EUT's whole sphere and different polarizations of the antenna.

Final measurement

- The final measurement is performed at the position and antenna orientation causing the highest emissions with Peak and RMS detector (as described in ANSI C 63.4).
- Final levels, frequency, measuring time, bandwidth, correction factor, margin to the limit and limit are recorded. A plot with the graph of the premeasurement and the limit is stored.

9 Measurement uncertainty

Measurement uncertainty		
Test case	Uncertainty	
Antenna gain	± 3 dB	
Power spectral density	± 1.56 dB	
DTS bandwidth	± 100 kHz (depends on the used RBW)	
Occupied bandwidth	± 100 kHz (depends on the used RBW)	
Maximum output power conducted	± 1.56 dB	
Detailed spurious emissions @ the band edge - conducted	± 1.56 dB	
Band edge compliance radiated	± 3 dB	
Spurious emissions conducted	> 3.6 GHz	± 1.56 dB
	> 7 GHz	± 1.56 dB
	> 18 GHz	± 2.31 dB
	≥ 40 GHz	± 2.97 dB
Spurious emissions radiated below 30 MHz	± 3 dB	
Spurious emissions radiated 30 MHz to 1 GHz	± 3 dB	
Spurious emissions radiated 1 GHz to 12.75 GHz	± 3.7 dB	
Spurious emissions radiated above 12.75 GHz	± 4.5 dB	
Spurious emissions conducted below 30 MHz (AC conducted)	± 2.6 dB	

10 Summary of measurement results

<input type="checkbox"/>	No deviations from the technical specifications were ascertained
<input type="checkbox"/>	There were deviations from the technical specifications ascertained
<input checked="" type="checkbox"/>	This test report is only a partial test report. The content and verdict of the performed test cases are listed below.

TC Identifier	Description	Verdict	Date	Remark
RF-Testing	CFR Title 47 Part 15 RSS 247, Issue 3	See table	2024-02-06	Tests according customer demand.

Test specification clause	Test case	C	NC	NA	NP	Remark
-/-	Output power verification (cond.)	-/-				Declared
-/-	Antenna gain	-/-				Declared
U-NII Part 15	Duty cycle	-/-				-/-
§15.407(a) RSS - 247 (6.2.x.1)	Maximum output power (conducted & radiated)	<input type="checkbox"/>	<input type="checkbox"/>	<input type="checkbox"/>	<input checked="" type="checkbox"/>	-/-
§15.407(a) RSS - 247 (6.2.x.1)	Power spectral density	<input type="checkbox"/>	<input type="checkbox"/>	<input type="checkbox"/>	<input checked="" type="checkbox"/>	-/-
RSS - 247 (6.2.4.1)	Spectrum bandwidth 6dB bandwidth	<input type="checkbox"/>	<input type="checkbox"/>	<input type="checkbox"/>	<input checked="" type="checkbox"/>	-/-
§15.407(a) RSS - 247 (6.2.x.2)	Spectrum bandwidth 26dB bandwidth	<input type="checkbox"/>	<input type="checkbox"/>	<input type="checkbox"/>	<input checked="" type="checkbox"/>	-/-
RSS Gen clause 6.6	Spectrum bandwidth 99% bandwidth	-/-				-/-
§15.205 RSS - 247 (6.2.x.2)	Band edge compliance radiated	<input checked="" type="checkbox"/>	<input type="checkbox"/>	<input type="checkbox"/>	<input type="checkbox"/>	-/-
§15.407(b) RSS - 247 (6.2.x.2)	TX spurious emissions radiated	<input checked="" type="checkbox"/>	<input type="checkbox"/>	<input type="checkbox"/>	<input type="checkbox"/>	-/-
§15.109 RSS-Gen	RX spurious emissions radiated	<input type="checkbox"/>	<input type="checkbox"/>	<input type="checkbox"/>	<input checked="" type="checkbox"/>	-/-
§15.209(a) RSS-Gen	Spurious emissions radiated < 30 MHz	<input type="checkbox"/>	<input type="checkbox"/>	<input type="checkbox"/>	<input checked="" type="checkbox"/>	-/-
§15.107(a) §15.207	Spurious emissions conducted emissions< 30 MHz	<input type="checkbox"/>	<input type="checkbox"/>	<input type="checkbox"/>	<input checked="" type="checkbox"/>	-/-
§15.407 RSS - 247 (6.3)	DFS	-/-				

Notes:

C:	Compliant	NC:	Not compliant	NA:	Not applicable	NP:	Not performed
----	-----------	-----	---------------	-----	----------------	-----	---------------

11 Additional comments

Reference documents: None

Special test descriptions: None

Configuration descriptions: None

- EUT selection:
- Only one device available
 - Devices selected by the customer
 - Devices selected by the laboratory (Randomly)

Provided channels:

Channels with 20 MHz channel bandwidth:

U-NII-1 & U-NII-2A (5150 MHz to 5250 MHz & 5250 MHz to 5350 MHz) channel number & center frequency								
channel	36	40	44	48	52	56	60	64
f _c / MHz	5180	5200	5220	5240	5260	5280	5300	5320

U-NII-2C (5470 MHz to 5725 MHz) channel number & center frequency											
channel	100	104	108	112	116	120	124	128	132	136	140
f _c / MHz	5500	5520	5540	5560	5580	5600	5620	5640	5660	5680	5700

U-NII-3 (5725 MHz to 5850 MHz) channel number & center frequency					
channel	149	153	157	161	165
f _c / MHz	5745	5765	5785	5805	5825

U-NII-5 (5925 MHz to 6425 MHz) channel number & center frequency								
channel	1	5	9	13	17	21	25	29
f _c / MHz	5955	5975	5995	6015	6035	6055	6075	6095
channel	33	37	41	45	49	53	57	61
f _c / MHz	6115	6135	6155	6175	6195	6215	6235	6255
channel	65	69	73	77	81	85	89	93
f _c / MHz	6275	6295	6315	6335	6355	6375	6395	6415

U-NII-6 (6425 MHz to 6525 MHz) channel number & center frequency					
channel	97	101	105	109	113
f _c / MHz	6435	6455	6475	6495	6515

U-NII-7 (6525 MHz to 6875 MHz) channel number & center frequency								
channel	117	121	125	129	133	137	141	145
f _c / MHz	6535	6555	6575	6595	6615	6635	6655	6675
channel	149	153	157	161	165	169	173	177
f _c / MHz	6695	6715	6735	6755	6775	6795	6815	6835
channel	181	185						
f _c / MHz	6855	6875						

U-NII-8 (6875 MHz to 7125 MHz)						
channel	189	193	197	201	205	209
f _c / MHz	6895	6915	6935	6955	6975	6995
channel	213	217	221	225	229	233
f _c / MHz	7015	7035	7055	7075	7095	7115

Channels with 40 MHz channel bandwidth:

U-NII-1 & U-NII-2A (5150 MHz to 5250 MHz & 5250 MHz to 5350 MHz) channel number & center frequency				
channel	38	46	54	62
f _c / MHz	5190	5230	5270	5310

U-NII-2C (5470 MHz to 5725 MHz) channel number & center frequency					
channel	102	110	118	126	134
f _c / MHz	5510	5550	5590	5630	5670

U-NII-3 (5725 MHz to 5850 MHz) channel number & center frequency		
channel	151	159
f _c / MHz	5755	5795

U-NII-5 (5925 MHz to 6425 MHz) channel number & center frequency						
channel	3	11	19	27	35	43
f _c / MHz	5965					
	51	59	67	75	83	91
	6205					6405

U-NII-6 (6425 MHz to 6525 MHz) channel number & center frequency			
channel	99	107	115
f _c / MHz	6445	6485	

U-NII-7 (6525 MHz to 6875 MHz) channel number & center frequency								
channel	123	131	139	147	155	163	171	179
f _c / MHz	6565			6685				6845

U-NII-8 (6875 MHz to 7125 MHz)						
channel	187	195	203	211	219	227
f _c / MHz		6925		7005		7085

Channels with 80 MHz channel bandwidth:

U-NII-1 & U-NII-2A (5150 MHz to 5250 MHz & 5250 MHz to 5350 MHz) channel number & center frequency		
channel	42	58
f _c / MHz	5210	5290

U-NII-2C (5470 MHz to 5725 MHz) channel number & center frequency		
channel	106	122
f _c / MHz	5530	5610

U-NII-3 (5725 MHz to 5850 MHz) channel number & center frequency		
channel	155	
f _c / MHz	5775	

U-NII-5 (5925 MHz to 6425 MHz)						
channel	7	23	39	55	71	87
f _c / MHz	5985			6225		6385

U-NII-6 (6425 MHz to 6525 MHz) channel number & center frequency		
channel	103	119
f _c / MHz		6545

U-NII-7 (6525 MHz to 6875 MHz) channel number & center frequency				
channel	135	151	167	183
f _c / MHz	6625	6705	6785	

U-NII-8 (6875 MHz to 7125 MHz) channel number & center frequency		
channel	199	215
f _c / MHz	6945	7025

Channels with 160 MHz channel bandwidth:

U-NII-1 & U-NII-2A (5150 MHz to 5250 MHz & 5250 MHz to 5350 MHz) channel number & center frequency	
channel	50
f _c / MHz	5250

U-NII-2C (5470 MHz to 5725 MHz) channel number & center frequency	
channel	114
f _c / MHz	5570

U-NII-5 (5925 MHz to 6425 MHz)			
channel	15	47	79
f _c / MHz	6025	6185	6345

U-NII-6 (6425 MHz to 6525 MHz) channel number & center frequency	
channel	111
f _c / MHz	6505

U-NII-7 (6525 MHz to 6875 MHz) channel number & center frequency		
channel	143	175
f _c / MHz	6665	

U-NII-8 (6875 MHz to 7125 MHz) channel number & center frequency	
channel	207
f _c / MHz	6985

Note: The channels used for the tests were marked in bold in the list.

Test mode:

- No test mode available.
Iperf is used to transmit data to a companion device
- Special software is used.
EUT is transmitting pseudo random data by itself

Antennas and transmit operating modes:

- Operating mode 1 (single antenna)
 - Equipment with 1 antenna,
 - Equipment with 2 diversity antennas operating in switched diversity mode by which at any moment in time only 1 antenna is used,
 - Smart antenna system with 2 or more transmit/receive chains, but operating in a mode where only 1 transmit/receive chain is used)
- Operating mode 2 (multiple antennas, no beamforming)
 - Equipment operating in this mode contains a smart antenna system using two or more transmit/receive chains simultaneously but without beamforming.
- Operating mode 3 (multiple antennas, with beamforming)
 - Equipment operating in this mode contains a smart antenna system using two or more transmit/receive chains simultaneously with beamforming.
In addition to the antenna assembly gain (G), the beamforming gain (Y) may have to be taken into account when performing the measurements.

12 Measurement results

12.1 Band edge compliance radiated

Description:

Measurement of the radiated band edge compliance. The EUT is turned in the position that results in the maximum level at the band edge. Then a sweep over the corresponding restricted band is performed. The EUT is set to the lowest channel for the lower restricted band and to the highest channel for the upper restricted band. Measurement distance is 3m.

Measurement:

Measurement parameter	
Detector:	Peak / RMS
Sweep time:	Auto
Resolution bandwidth:	1 MHz
Video bandwidth:	$\geq 3 \times \text{RBW}$
Span:	See plots!
Trace mode:	Max Hold
Test setup:	See sub clause 7.2 – A
Measurement uncertainty:	See chapter 9

Limits:

Band Edge Compliance Radiated
In any 100 kHz bandwidth outside the frequency band in which the spread spectrum or digitally modulated intentional radiator is operating, the radio frequency power that is produced by the intentional radiator shall be at least 20 dB below that in the 100 kHz bandwidth within the band that contains the highest level of the desired power, based on either an RF conducted or a radiated measurement. Attenuation below the general limits specified in Section 15.209(a) is not required. In addition, radiated emissions which fall in the restricted bands, as defined in Section 15.205(a), must also comply with the radiated emission limits specified in Section 15.209(a) (see Section 5.205(c)).
74 dB μ V/m (peak) 54 dB μ V/m (average)

Result:

Scenario	Band Edge Compliance Radiated [dB μ V/m]
band edge	< 74 dB μ V/m (peak) < 54 dB μ V/m (average)

Plots:

Plot 1: lower band edge; U-NII-1; lowest channel; a-mode

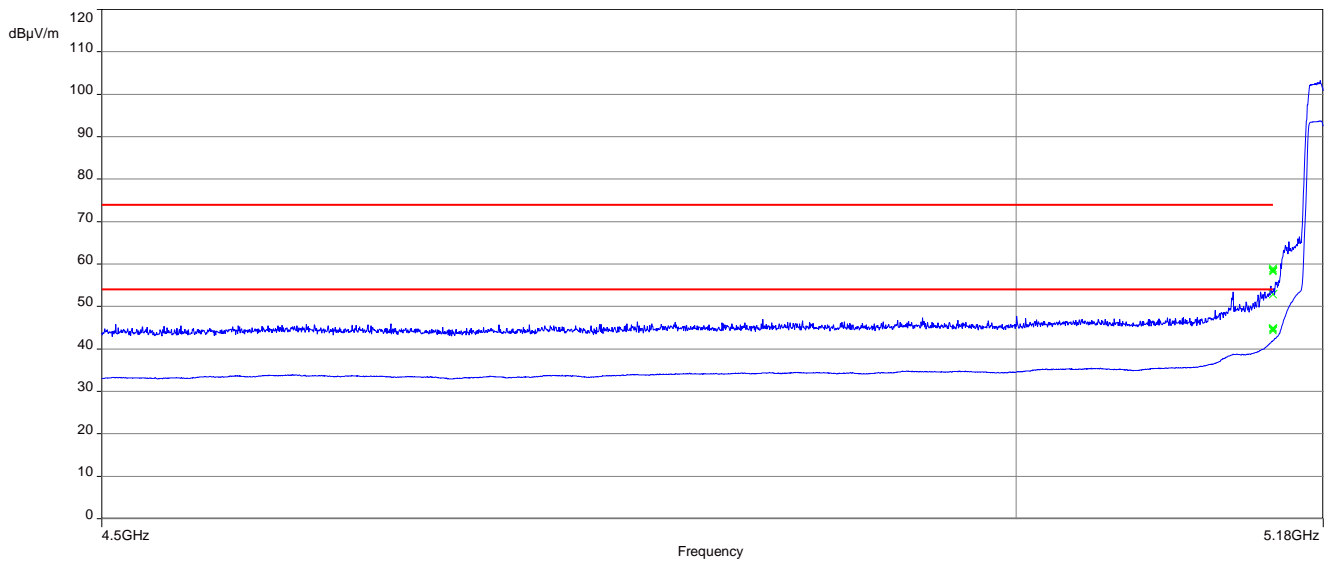

Plot 2: lower band edge; U-NII-1; lowest channel; n40-mode

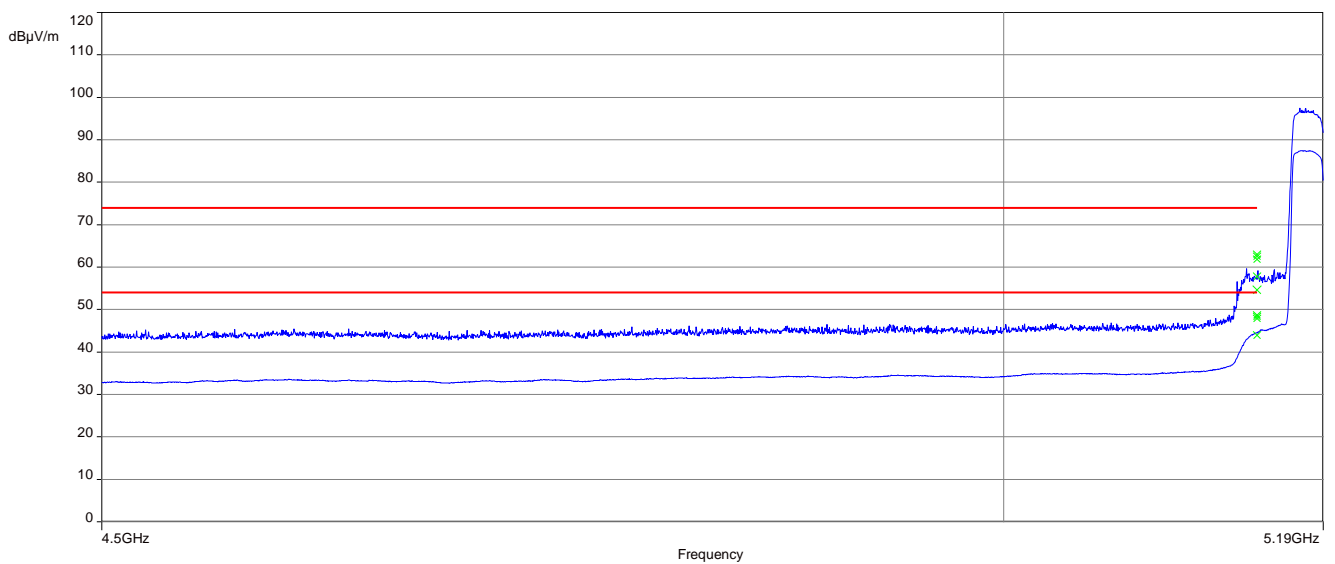

Plot 3: lower band edge; U-NII-1; middle channel; ac80-mode

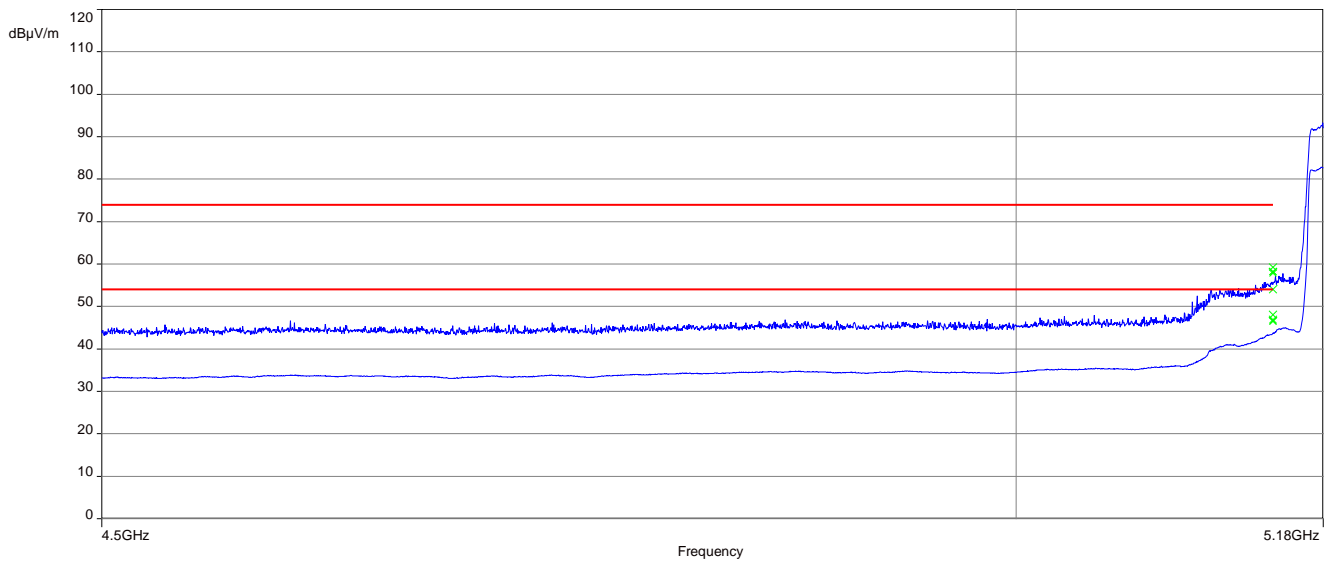

12.2 Spurious emissions radiated 1 GHz to 40 GHz

Description:

Measurement of the radiated spurious emissions and cabinet radiations from 1 GHz to 40 GHz.

Measurement:

Measurement parameter	
Detector:	Peak / RMS
Sweep time:	Auto
Resolution bandwidth:	1 MHz
Video bandwidth:	3 MHz
Span:	1 GHz to 40 GHz
Test setup:	See sub clause 7.1 – A See sub clause 7.2 – A See sub clause 7.3 – A
Measurement uncertainty:	See chapter 9

Limits:

TX Spurious Emissions Radiated		
§15.209 / RSS-247		
Frequency (MHz)	Field Strength (dBµV/m)	Measurement distance
Above 960	54.0	3
§15.407		
Outside the restricted bands!	-27 dBm / MHz	

Results: 20 MHz channel bandwidth

TX Spurious Emissions Radiated [dB μ V/m] / dBm								
U-NII-1 (5150 MHz to 5250 MHz)								
Lowest channel			Middle channel			Highest channel		
F [MHz]	Detector	Level [dB μ V/m]	F [MHz]	Detector	Level [dB μ V/m]	F [MHz]	Detector	Level [dB μ V/m]
	Peak			Peak			Peak	
	AVG			AVG			AVG	
	Peak			Peak			Peak	
	AVG			AVG			AVG	
For emissions above 18 GHz please take look at the plots.			For emissions above 18 GHz please take look at the plots.			For emissions above 18 GHz please take look at the plots.		

TX Spurious Emissions Radiated [dB μ V/m] / dBm								
U-NII-2A (5250 MHz to 5350 MHz)								
Lowest channel			Middle channel			Highest channel		
F [MHz]	Detector	Level [dB μ V/m]	F [MHz]	Detector	Level [dB μ V/m]	F [MHz]	Detector	Level [dB μ V/m]
	Peak			Peak			Peak	
	AVG			AVG			AVG	
	Peak			Peak			Peak	
	AVG			AVG			AVG	
For emissions above 18 GHz please take look at the plots.			For emissions above 18 GHz please take look at the plots.			For emissions above 18 GHz please take look at the plots.		

TX Spurious Emissions Radiated [dB μ V/m] / dBm								
U-NII-2C (5470 MHz to 5725 MHz)								
Lowest channel			Middle channel			Highest channel		
F [MHz]	Detector	Level [dB μ V/m]	F [MHz]	Detector	Level [dB μ V/m]	F [MHz]	Detector	Level [dB μ V/m]
	Peak			Peak			Peak	
	AVG			AVG			AVG	
	Peak			Peak			Peak	
	AVG			AVG			AVG	
For emissions above 18 GHz please take look at the plots.			For emissions above 18 GHz please take look at the plots.			For emissions above 18 GHz please take look at the plots.		

TX Spurious Emissions Radiated [dBµV/m] / dBm								
U-NII-3 (5725 MHz to 5850 MHz)								
Lowest channel			Middle channel			Highest channel		
F [MHz]	Detector	Level [dBµV/m]	F [MHz]	Detector	Level [dBµV/m]	F [MHz]	Detector	Level [dBµV/m]
	Peak			Peak			Peak	
	AVG			AVG			AVG	
	Peak			Peak			Peak	
	AVG			AVG			AVG	
For emissions above 18 GHz please take look at the plots.			For emissions above 18 GHz please take look at the plots.			For emissions above 18 GHz please take look at the plots.		

Results: 40 MHz channel bandwidth

TX Spurious Emissions Radiated [dBµV/m] / dBm								
U-NII-1 (5150 MHz to 5250 MHz)								
Lowest channel			Middle channel			Highest channel		
F [MHz]	Detector	Level [dBµV/m]	F [MHz]	Detector	Level [dBµV/m]	F [MHz]	Detector	Level [dBµV/m]
	Peak			Peak			Peak	
	AVG			AVG			AVG	
	Peak			Peak			Peak	
	AVG			AVG			AVG	
For emissions above 18 GHz please take look at the plots.			For emissions above 18 GHz please take look at the plots.			For emissions above 18 GHz please take look at the plots.		

TX Spurious Emissions Radiated [dBµV/m] / dBm								
U-NII-2A (5250 MHz to 5350 MHz)								
Lowest channel			Middle channel			Highest channel		
F [MHz]	Detector	Level [dBµV/m]	F [MHz]	Detector	Level [dBµV/m]	F [MHz]	Detector	Level [dBµV/m]
	Peak			Peak			Peak	
	AVG			AVG			AVG	
	Peak			Peak			Peak	
	AVG			AVG			AVG	
For emissions above 18 GHz please take look at the plots.			For emissions above 18 GHz please take look at the plots.			For emissions above 18 GHz please take look at the plots.		

TX Spurious Emissions Radiated [dBµV/m] / dBm								
U-NII-2C (5470 MHz to 5725 MHz)								
Lowest channel			Middle channel			Highest channel		
F [MHz]	Detector	Level [dBµV/m]	F [MHz]	Detector	Level [dBµV/m]	F [MHz]	Detector	Level [dBµV/m]
	Peak			Peak			Peak	
	AVG			AVG			AVG	
	Peak			Peak			Peak	
	AVG			AVG			AVG	
For emissions above 18 GHz please take look at the plots.			For emissions above 18 GHz please take look at the plots.			For emissions above 18 GHz please take look at the plots.		

TX Spurious Emissions Radiated [dB μ V/m] / dBm								
U-NII-3 (5725 MHz to 5850 MHz)								
Lowest channel			Middle channel			Highest channel		
F [MHz]	Detector	Level [dB μ V/m]	F [MHz]	Detector	Level [dB μ V/m]	F [MHz]	Detector	Level [dB μ V/m]
	Peak			Peak			Peak	
	AVG			AVG			AVG	
	Peak			Peak			Peak	
	AVG			AVG			AVG	
For emissions above 18 GHz please take look at the plots.			For emissions above 18 GHz please take look at the plots.			For emissions above 18 GHz please take look at the plots.		

Results: 80 MHz channel bandwidth

TX Spurious Emissions Radiated [dB μ V/m] / dBm		
U-NII-1 (5150 MHz to 5250 MHz)		
Middle channel		
F [MHz]	Detector	Level [dB μ V/m]
	Peak	
	AVG	
	Peak	
	AVG	
For emissions above 18 GHz please take look at the plots.		

TX Spurious Emissions Radiated [dB μ V/m] / dBm		
U-NII-2A (5250 MHz to 5350 MHz)		
Middle channel		
F [MHz]	Detector	Level [dB μ V/m]
	Peak	
	AVG	
	Peak	
	AVG	
For emissions above 18 GHz please take look at the plots.		

TX Spurious Emissions Radiated [dB μ V/m] / dBm					
U-NII-2C (5470 MHz to 5725 MHz)					
Lowest channel			Highest channel		
	Peak			Peak	
	AVG			AVG	
	Peak			Peak	
	AVG			AVG	
For emissions above 18 GHz please take look at the plots.			For emissions above 18 GHz please take look at the plots.		

TX Spurious Emissions Radiated [dB μ V/m] / dBm		
U-NII-3 (5725 MHz to 5850 MHz)		
Middle channel		
F [MHz]	Detector	Level [dB μ V/m]
	Peak	
	AVG	
	Peak	
	AVG	
For emissions above 18 GHz please take look at the plots.		

Plots: 20 MHz channel bandwidth

Plot 1: 1 GHz to 18 GHz; vertical & horizontal polarization; U-NII-1; lowest channel

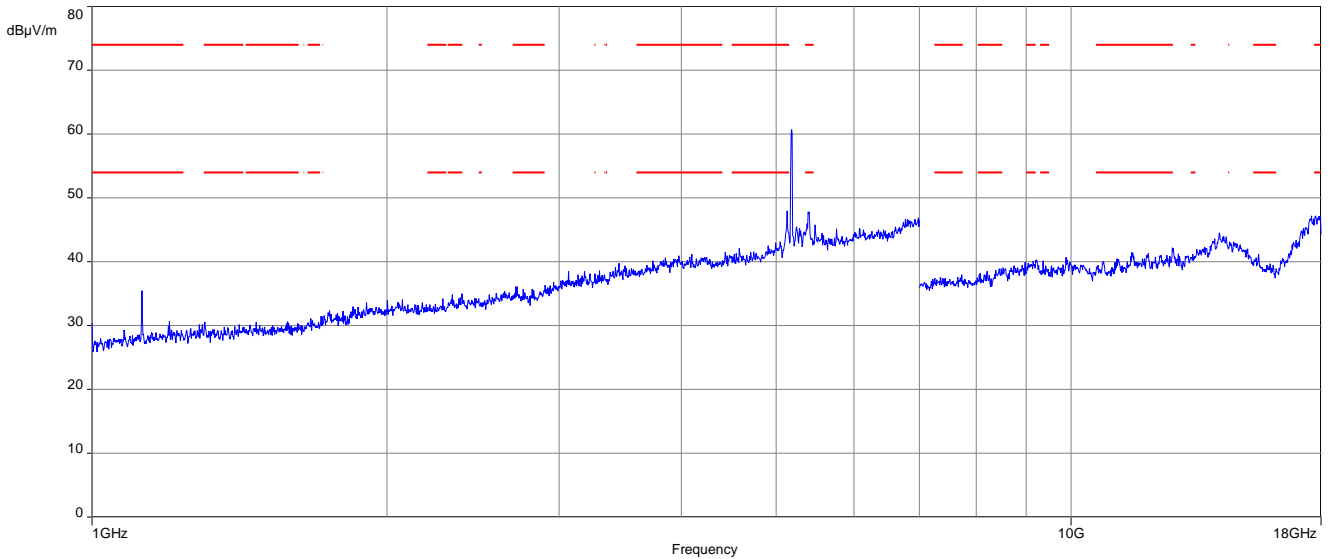

Plot 2: 18 GHz to 26 GHz; vertical & horizontal polarization; U-NII-1; lowest channel

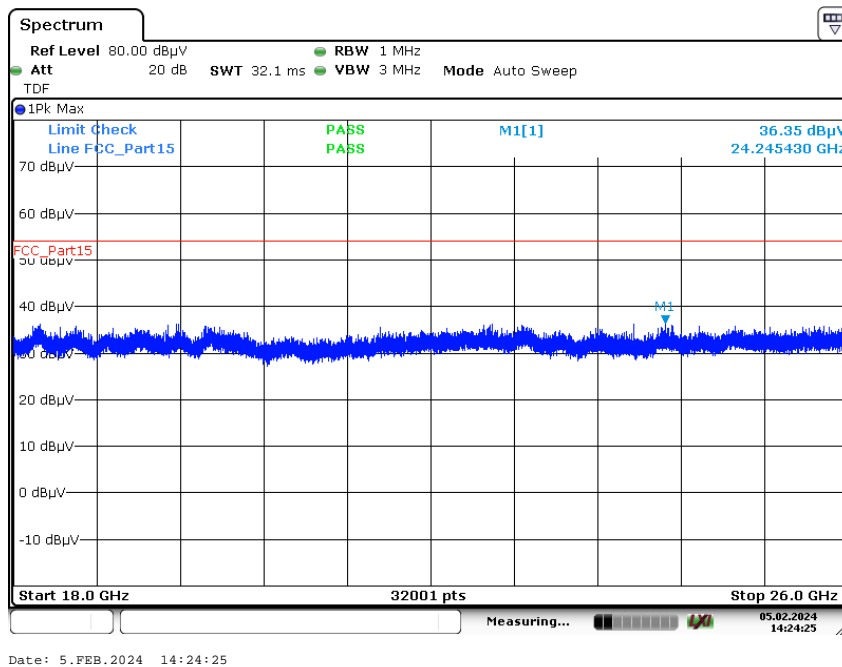

Plot 3: 26 GHz to 40 GHz; vertical & horizontal polarization; U-NII-1; lowest channel

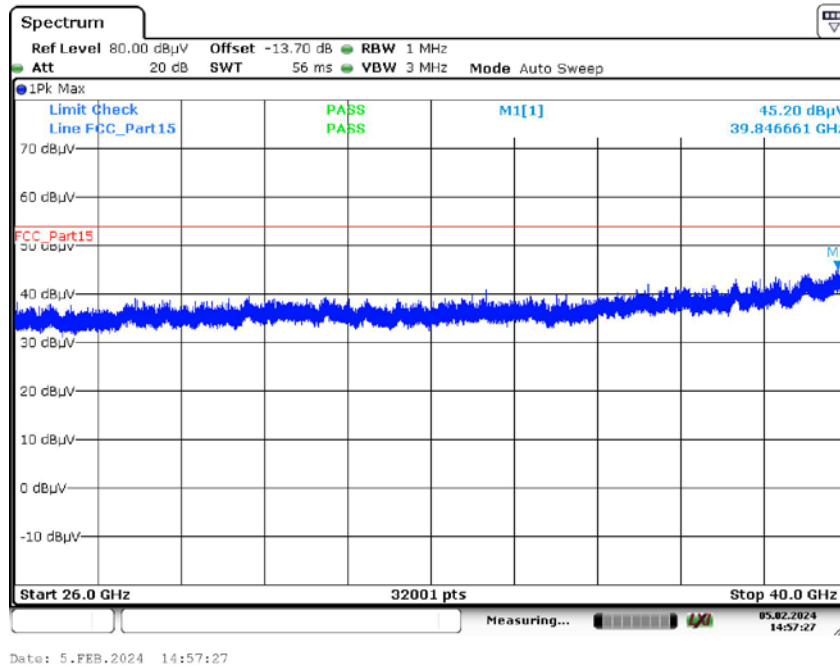

Plot 4: 1 GHz to 18 GHz; vertical & horizontal polarization; U-NII-1; middle channel

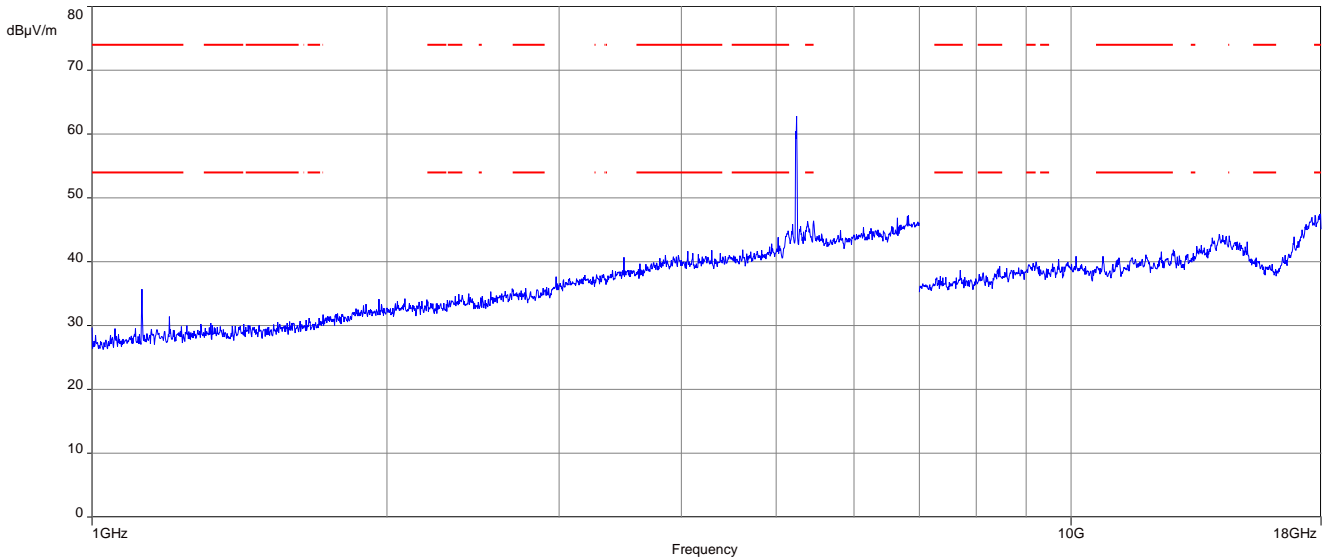

Plot 5: 18 GHz to 26 GHz; vertical & horizontal polarization; U-NII-1; middle channel

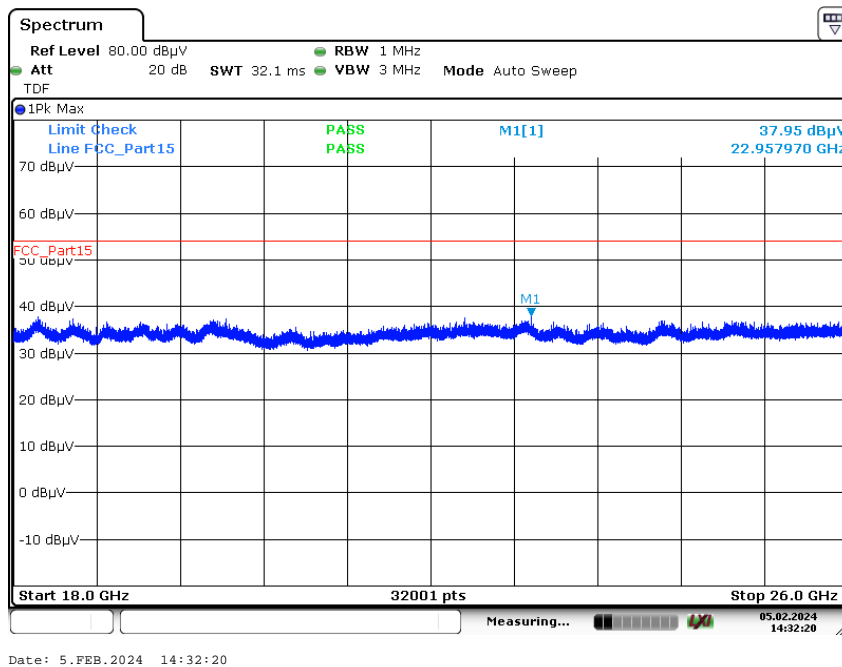

Plot 6: 26 GHz to 40 GHz; vertical & horizontal polarization; U-NII-1; middle channel

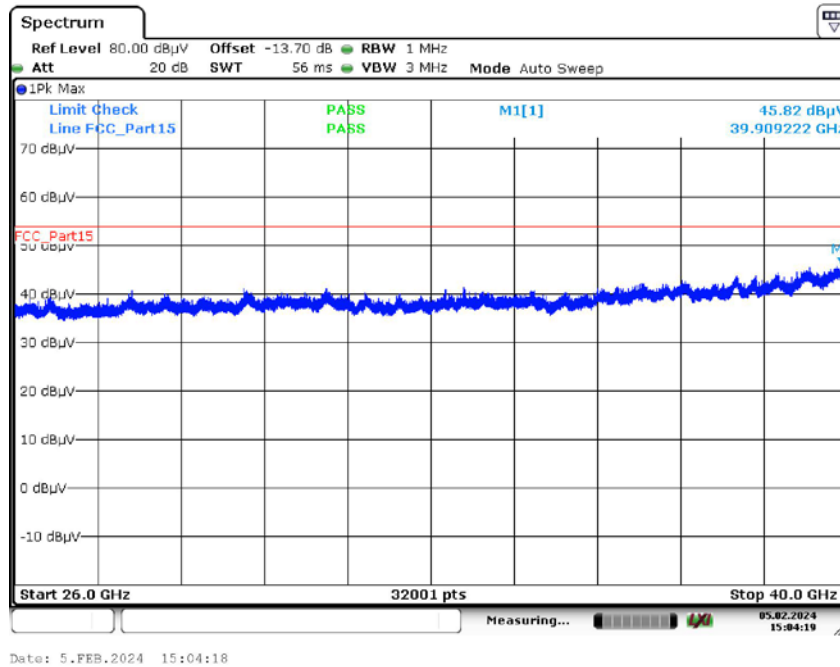

Plot 7: 1 GHz to 18 GHz; vertical & horizontal polarization; U-NII-3; highest channel

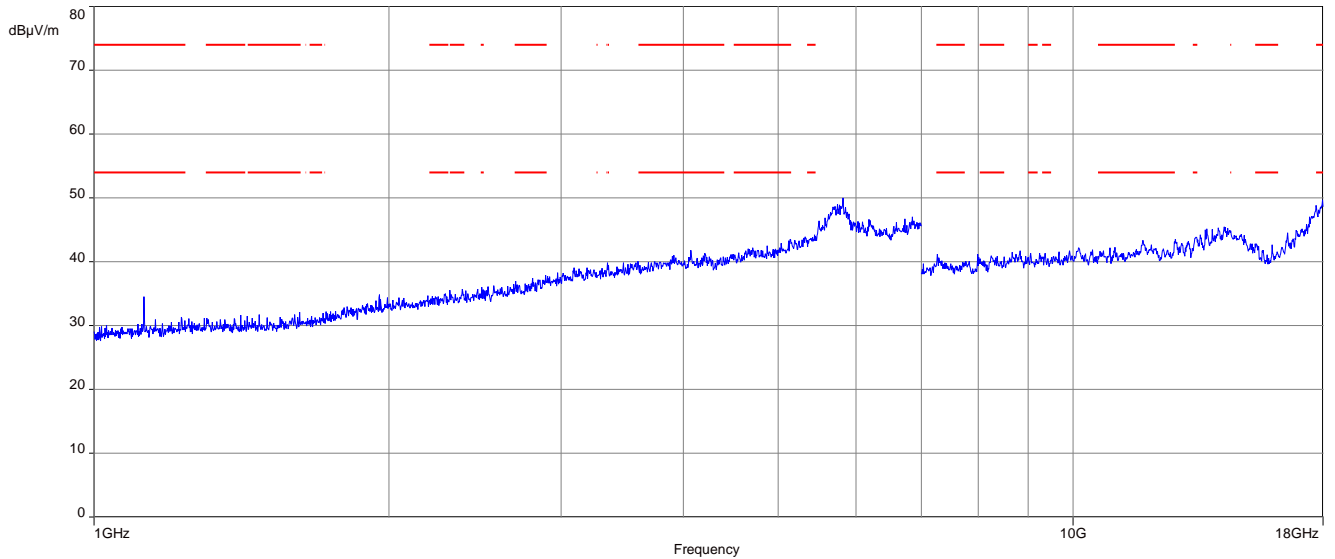

Plot 8: 18 GHz to 26 GHz; vertical & horizontal polarization; U-NII-3; highest channel

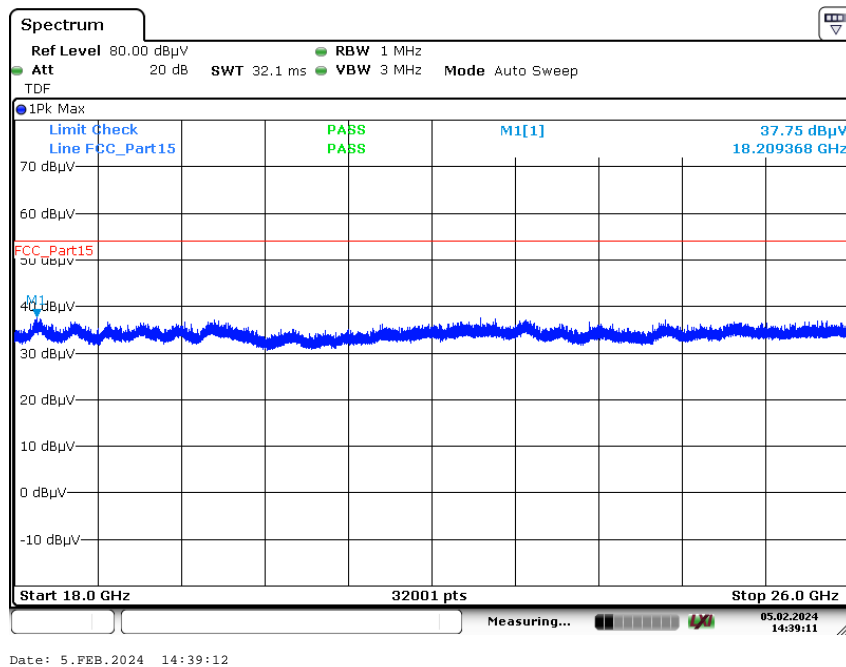

Plot 9: 26 GHz to 40 GHz; vertical & horizontal polarization; U-NII-3; highest channel

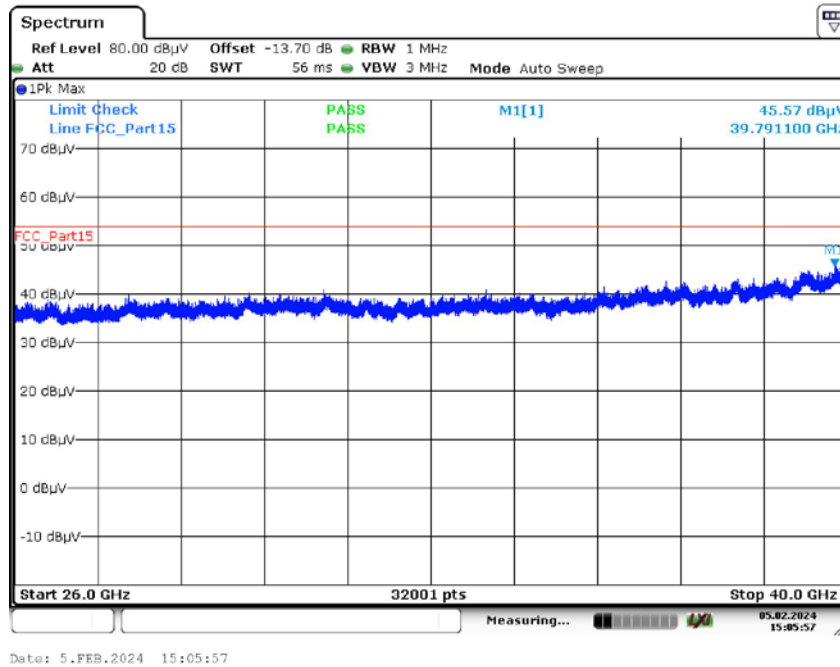

Plots: 40 MHz channel bandwidth

Plot 1: 1 GHz to 18 GHz; vertical & horizontal polarization; U-NII-1; lowest channel

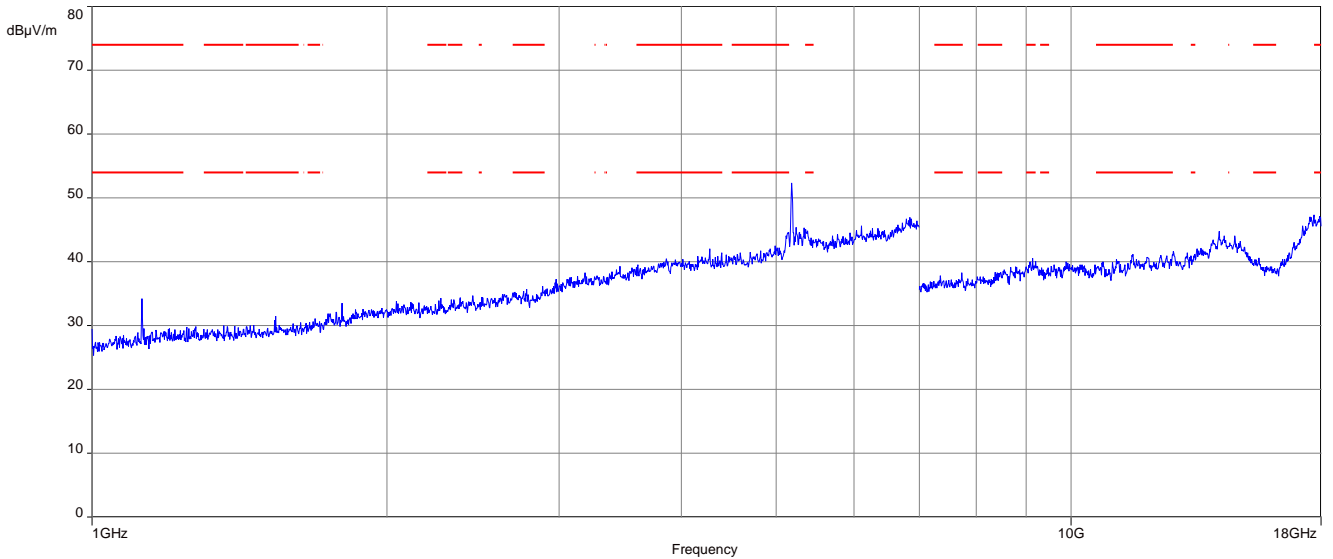

Plot 2: 18 GHz to 26 GHz; vertical & horizontal polarization; U-NII-1; lowest channel

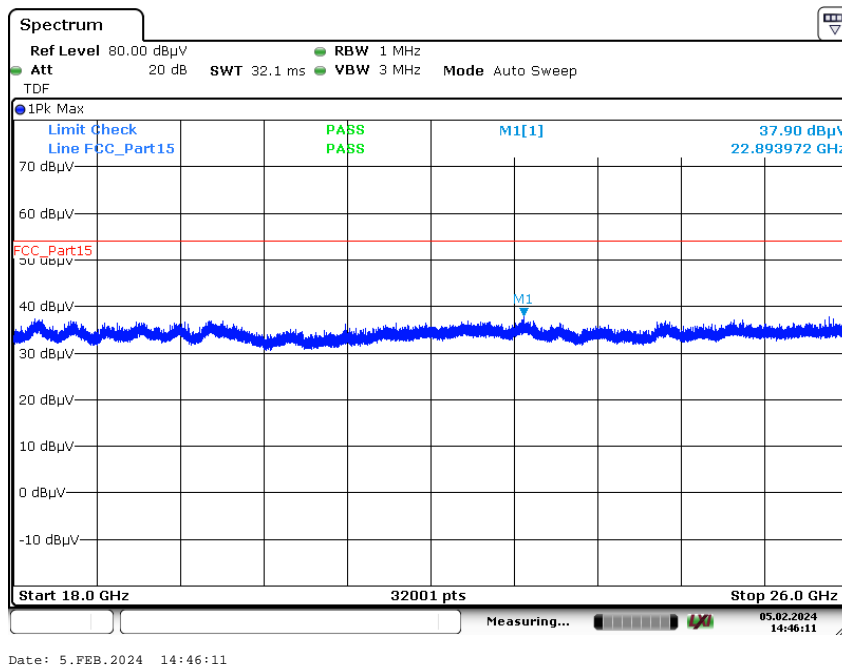

Plot 3: 26 GHz to 40 GHz; vertical & horizontal polarization; U-NII-1; lowest channel

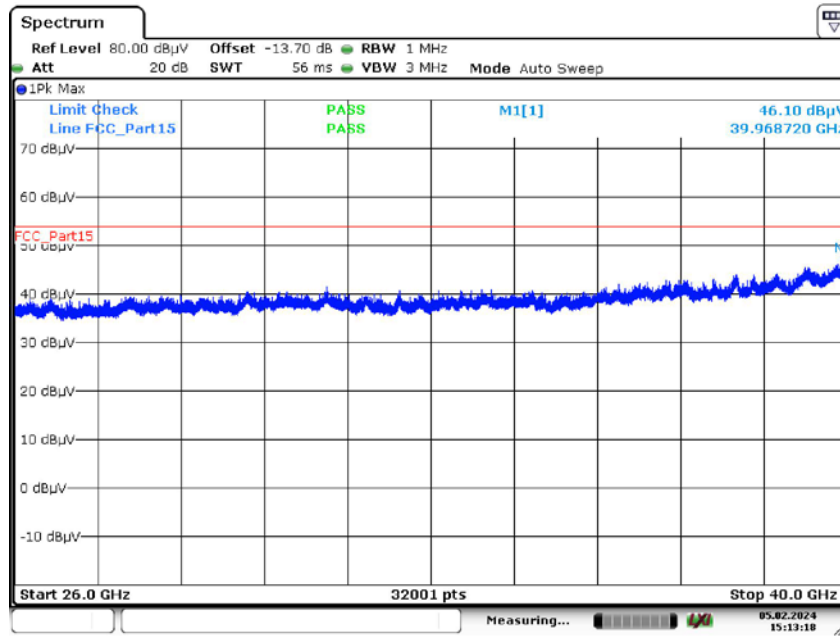

Plots: 80 MHz channel bandwidth

Plot 1: 1 GHz to 18 GHz; vertical & horizontal polarization; U-NII-1; middle channel

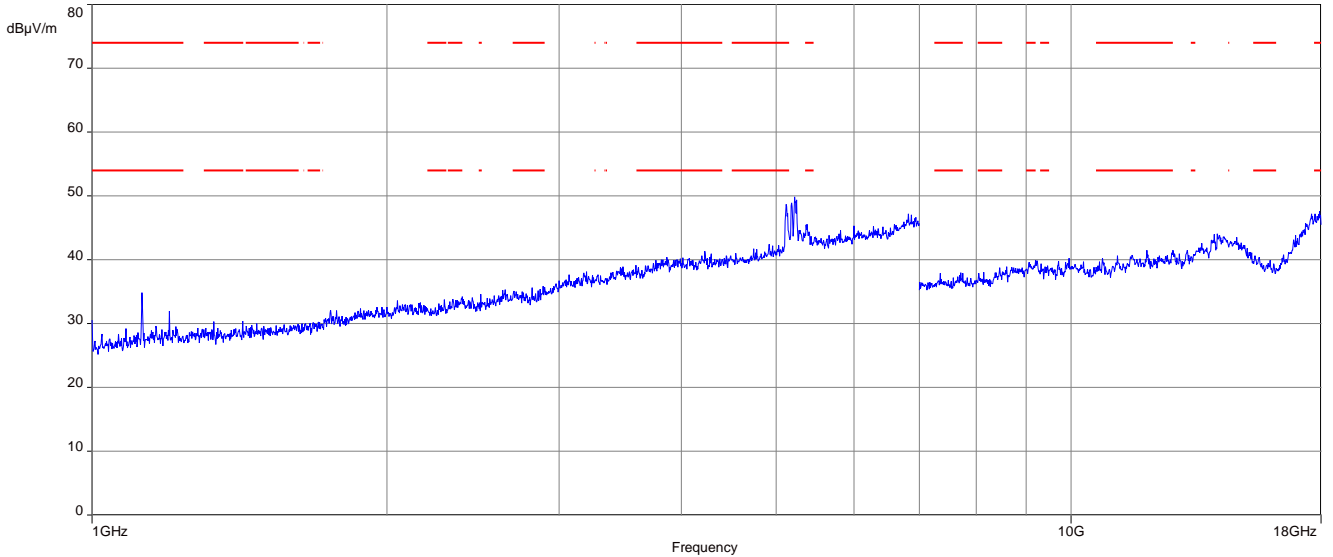

Plot 2: 18 GHz to 26 GHz; vertical & horizontal polarization; U-NII-1; middle channel

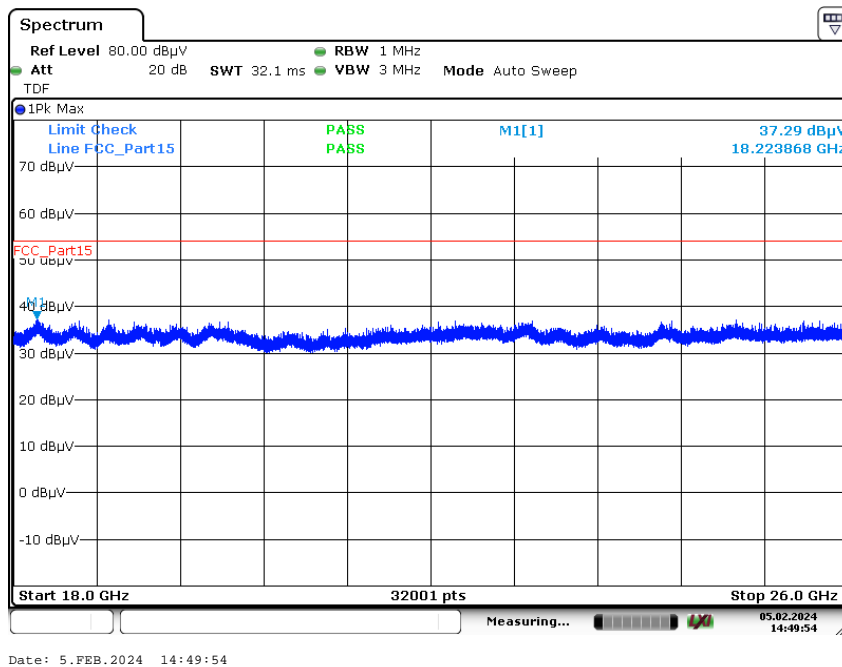

Plot 3: 26 GHz to 40 GHz; vertical & horizontal polarization; U-NII-1; middle channel

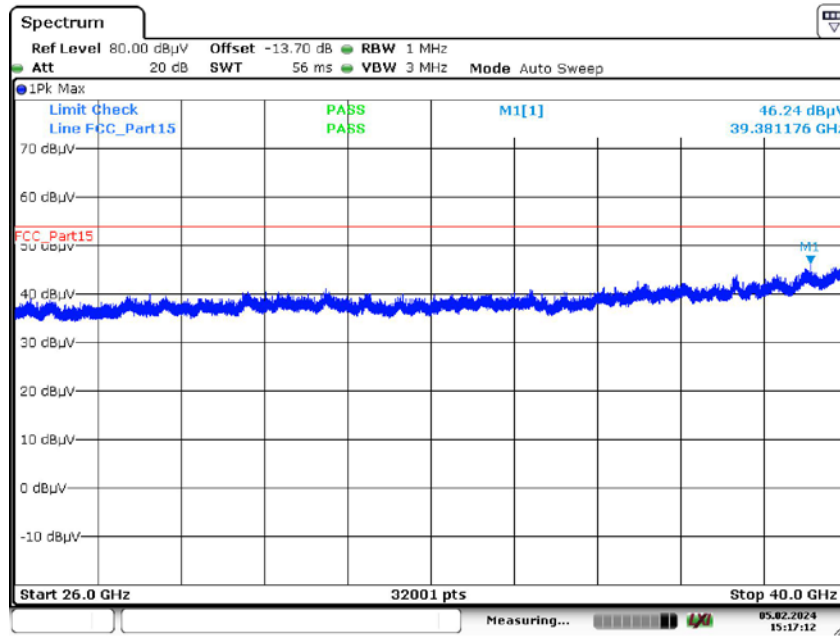

Date: 5.FEB.2024 15:17:13

Plot 4: 1 GHz to 18 GHz; vertical & horizontal polarization; U-NII-3; middle channel

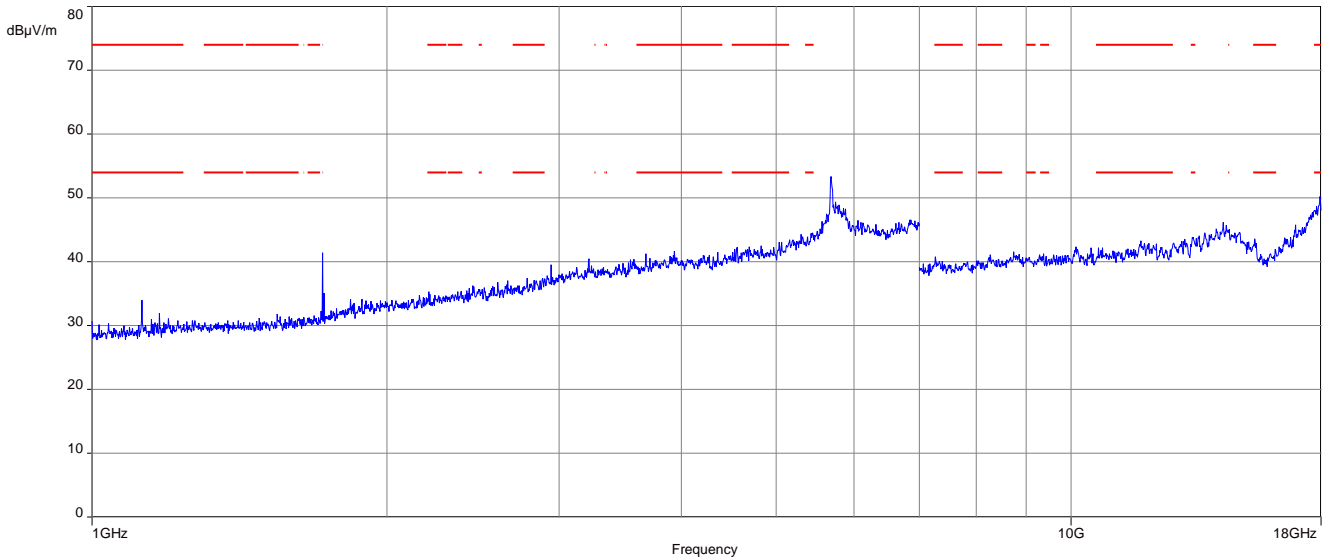

Plot 5: 18 GHz to 26 GHz; vertical & horizontal polarization; U-NII-3; middle channel

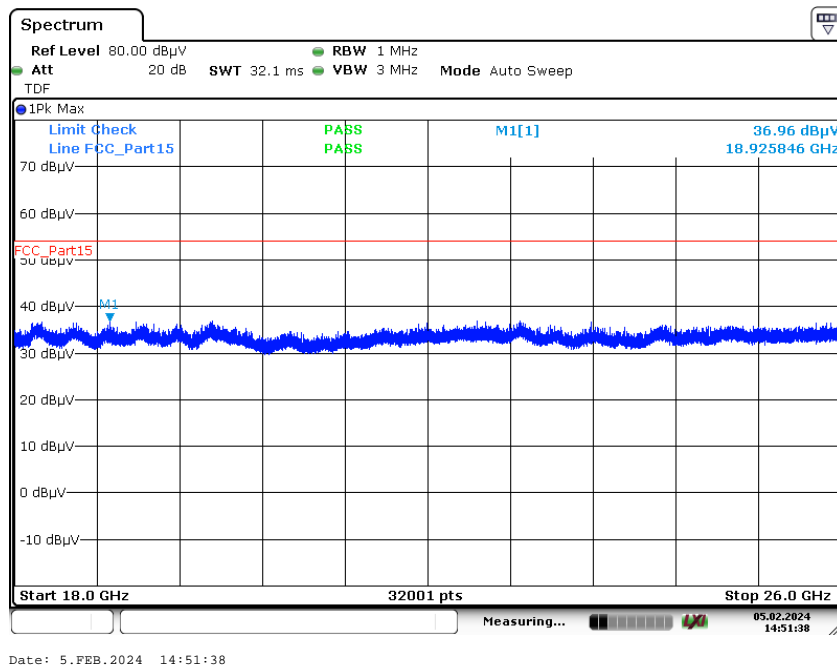

Plot 6: 26 GHz to 40 GHz; vertical & horizontal polarization; U-NII-3; middle channel

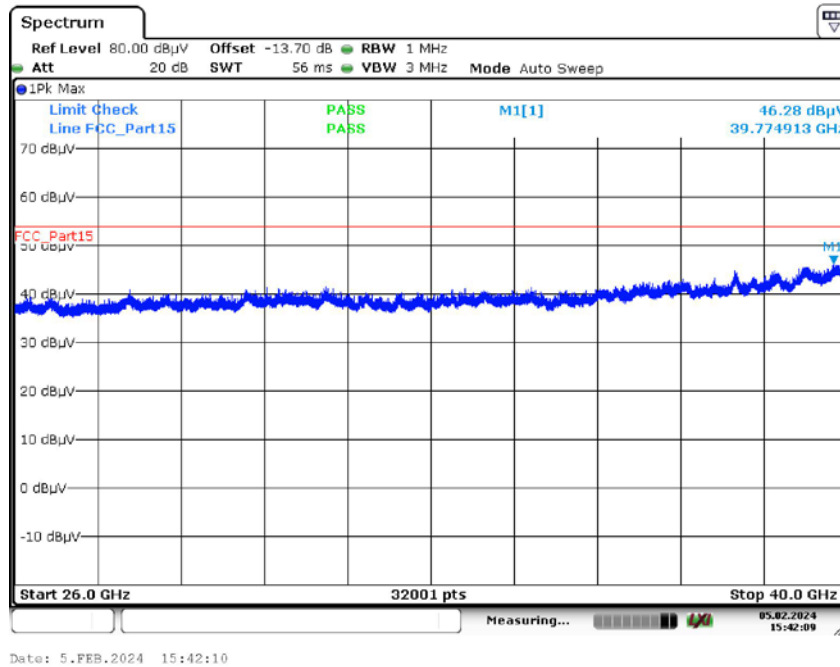

13 Glossary

AVG	Average
C	Compliant
C/N₀	Carrier to noise-density ratio, expressed in dB-Hz
CAC	Channel availability check
CW	Clean wave
DC	Duty cycle
DFS	Dynamic frequency selection
DSSS	Dynamic sequence spread spectrum
DUT	Device under test
EN	European Standard
ETSI	European Telecommunications Standards Institute
EMC	Electromagnetic Compatibility
EUT	Equipment under test
FCC	Federal Communications Commission
FCC ID	Company Identifier at FCC
FHSS	Frequency hopping spread spectrum
FVIN	Firmware version identification number
GNSS	Global Navigation Satellite System
GUE	GNSS User Equipment
HMN	Host marketing name
HVIN	Hardware version identification number
HW	Hardware
IC	Industry Canada
Inv. No.	Inventory number
MC	Modulated carrier
NA	Not applicable
NC	Not compliant
NOP	Non occupancy period
NP	Not performed
OBW	Occupied bandwidth
OC	Operating channel
OCW	Operating channel bandwidth
OFDM	Orthogonal frequency division multiplexing
OOB	Out of band
OP	Occupancy period
PER	Packet error rate
PMN	Product marketing name
PP	Positive peak
QP	Quasi peak
RLAN	Radio local area network
S/N or SN	Serial number
SW	Software
UUT	Unit under test
WLAN	Wireless local area network

14 Document history

Version	Applied changes	Date of release
-/-	Initial release	2024-02-06

END OF TEST REPORT