

NOTES: UNLESS OTHERWISE SPECIFIED

- 1. INTERPRET DRAWING IN ACCORDANCE WITH ASME Y14.5M-2009.
- 2. THIS ASSEMBLY SHALL MEET THE WORKMANSHIP REQUIREMENTS OF IPC-A-610, CLASS 2.
- 3. CAUTION: THIS ASSEMBLY CONTAINS DEVICES SUSCEPTIBLE TO DAMAGE BY ELECTROSTATIC DISCHARGE. HANDLE PER ESD PROCEDURES OF IPC-A-610 AND ANSI/ESD S20.20.
- 4. TORQUE HARDWARE PER TABLE 1. TORQUE FASTENER PER PS-6025.

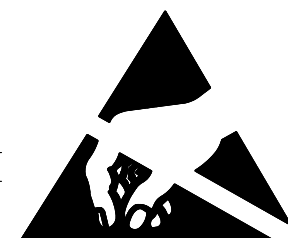

- 5. PRIOR TO INSTALLATION OF SCREWS APPLY PRIMER (FIND NO. 81) AND THREADLOCKER (FIND NO. 80) TO SCREW THREADS PER PS-7091, TYPE 2 CLASS A.
- 6. APPLY LABELS IN APPROXIMATE LOCATIONS SHOWN. TEXT IN LABELS FOR ORIENTATION PURPOSES ONLY.
- 7. MARK SW LABEL (FIND NO. 25) USING QR CODE AS PER ISO/IEC 18004:2015 VERSION 5, ENCODING ISO-8859-1, ERROR CORRECTION M OF MINIMUM SIZE OF .45 X .45 FOR THE MODULE (S/N, P/N, USER PW, RESET PW) USING THE FORMAT: ("sn":"123456","pn":"90600736", "up":"u3ERpSwd","rp":"R3stPSwD")
- 8. MARK CHASSIS QR LABEL (FIND NO. 28) QR CODE AS PER ISO/IEC 18004:2015 VERSION 5, ENCODING ISO-8859-1, ERROR CORRECTION M OF MINIMUM SIZE OF .45 X .45 FOR THE MODULE (S/N, P/N) USING THE FORMAT: ("sn":"123456","pn":"90600736")
- 9. MARK ID LABEL (FIND NO. 24) WITH DATA BELOW. MARKED CHARACTERS SHALL BE HONEYWELL SANS MEDIUM, .06 HIGH MINIMUM. MARK ID LABEL WITH: DESCRIPTION: HONEYWELL SATCOM 5G P/N: 90600736 REV: X CAGE CODE: 38473 DATE: MMM.YY NOMINAL WEIGHT: .59 kg 1.30 lb

- 10. MARK SOFTWARE LABEL (FIND NO. 25) WITH DATA BELOW. MARKED CHARACTERS SHALL BE HONEYWELL SANS MEDIUM, .06 HIGH MINIMUM.

S/N: XXXXXX

USER ACCOUNT
PASSWORD (UNIQUE 8 CHARACTERS, RANDOMLY GENERATED WITH UPPER CASE, LOWER CASE AND NUMBERS), EXCLUDING "L","I","1","l","4","o","0".

RESET ACCOUNT
PASSWORD (UNIQUE 8 CHARACTERS, RANDOMLY GENERATED WITH UPPER CASE, LOWER CASE AND NUMBERS), EXCLUDING "L","I","1","l","4","o","0".

- 11. ENSURE CABLES (FIND NO. 29) ARE NOT PINCHED WHEN BRM (FIND NO. 40) IS FASTENED TO CHASSIS (FIND NO. 1).
- 12. ROUTE CABLES (FIND NO. 29) THROUGH HOLES ON DIGITAL CARD (FIND NO. 45) AND RF CARD (FIND NO. 44). CONNECT CABLES TO RF CARD.
- 13. ENSURE CABLES (FIND NO. 30) ARE ROUTED THROUGH THE CABLE CLIPS (PART OF AP CARD FIND NO. 43). TWO CABLES PER CLIP.

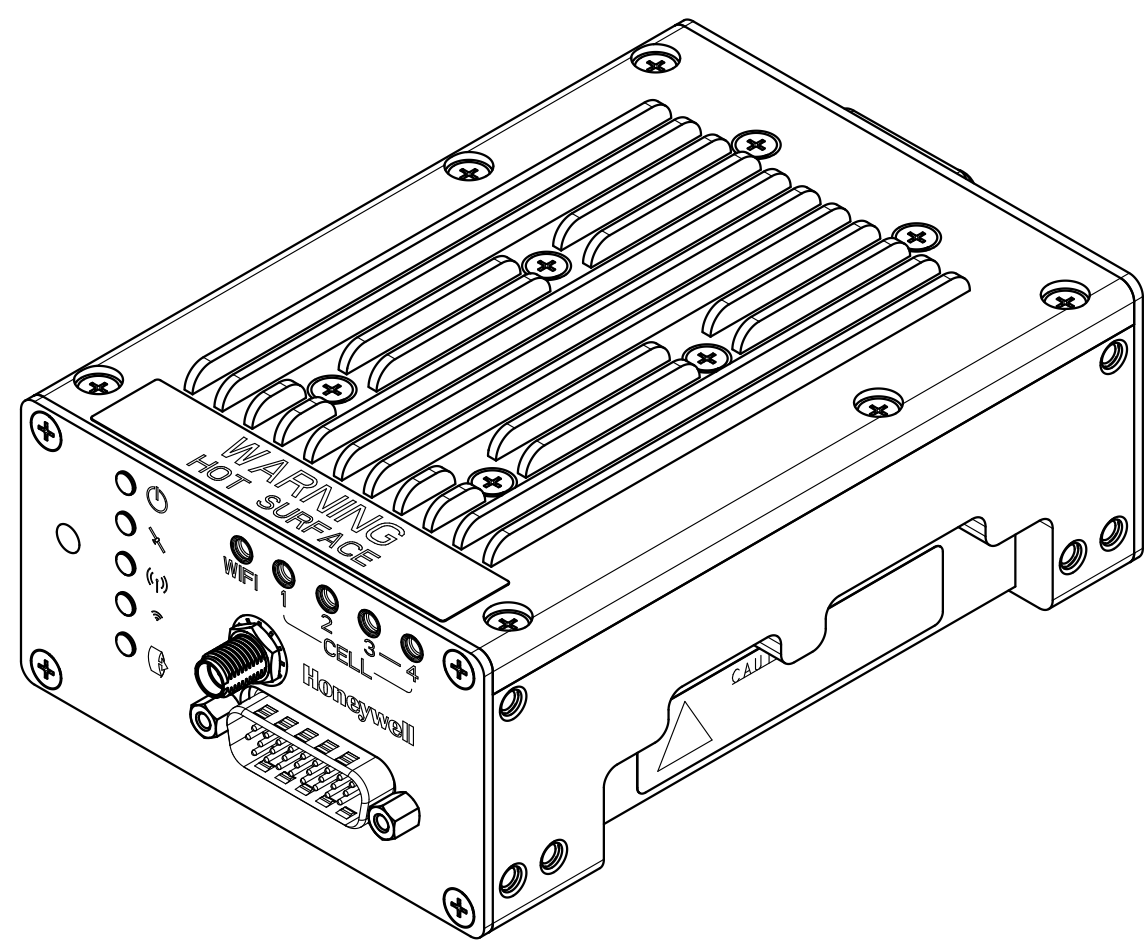

DATUM	XX																	LAST LTR USED	XX
LOCATION	XX-XX																	ALSO USED	XX

CAD MAINTAINED. CHANGES SHALL BE INCORPORATED BY THE CURRENT DESIGN ACTIVITY				
REVISION HISTORY - ALL SHEETS ARE THE SAME REVISION				
ZONE	REV	DESCRIPTION	DATE	APPROVED
	A	PRODUCTION RELEASE PER ECN-8207532	SEE ECN	SEE ECN
	B	REVISED PER ECN-8208643	SEE ECN	SEE ECN

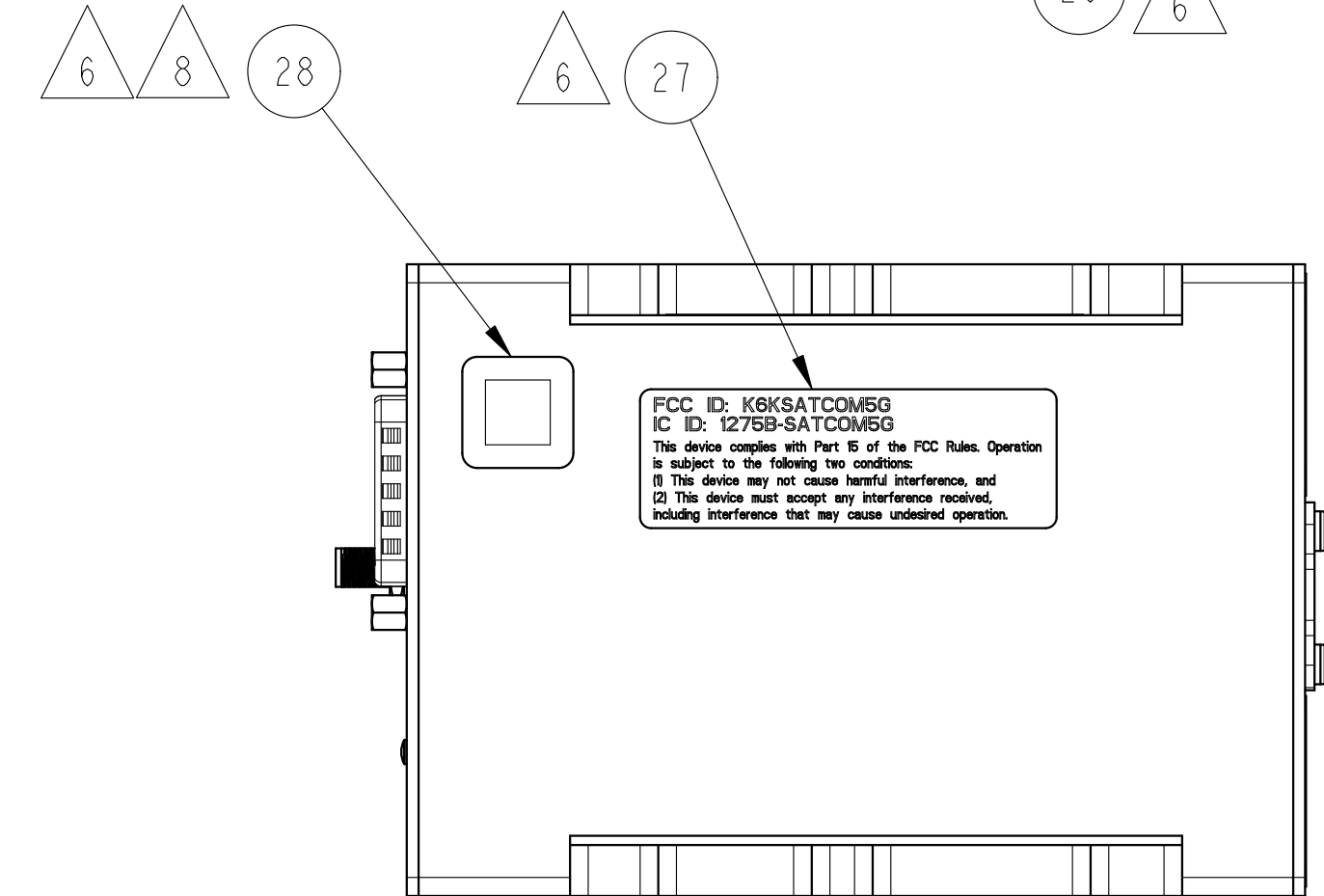
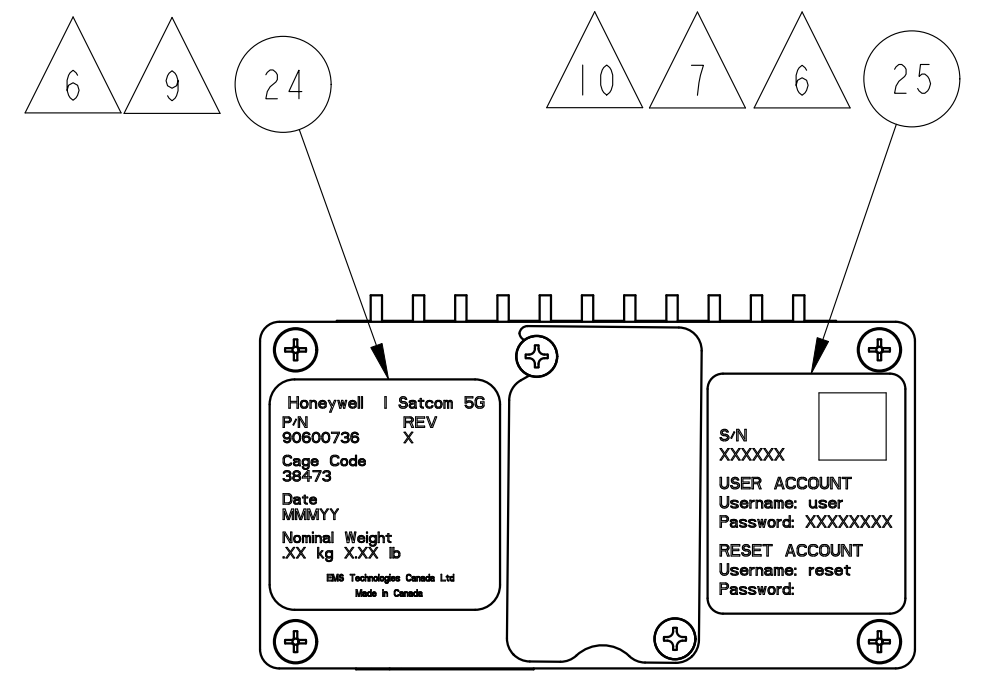
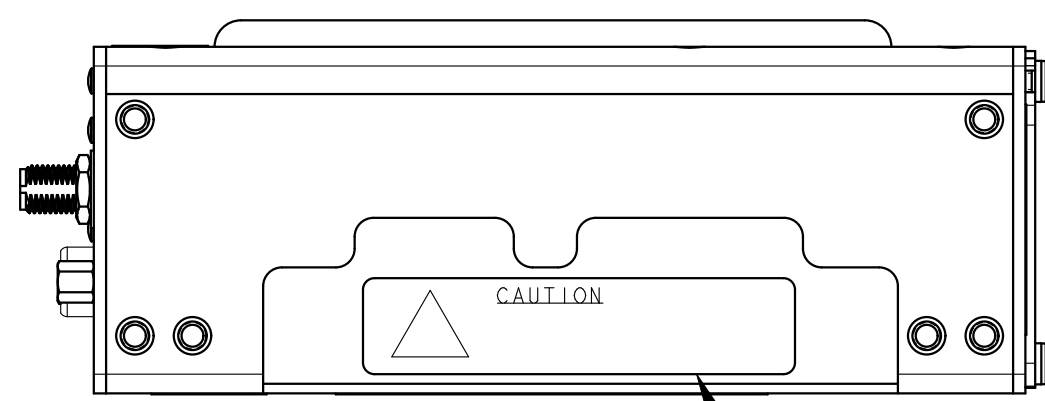
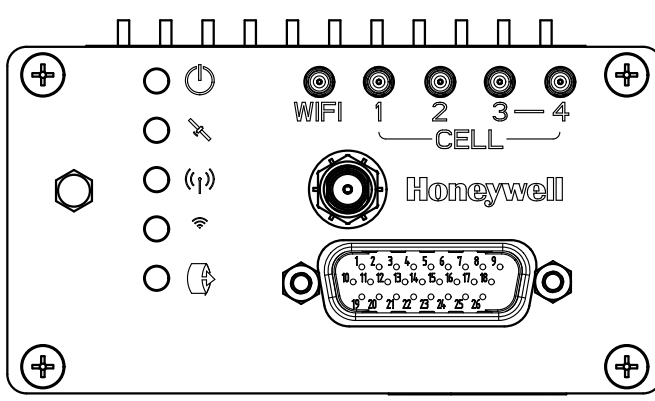
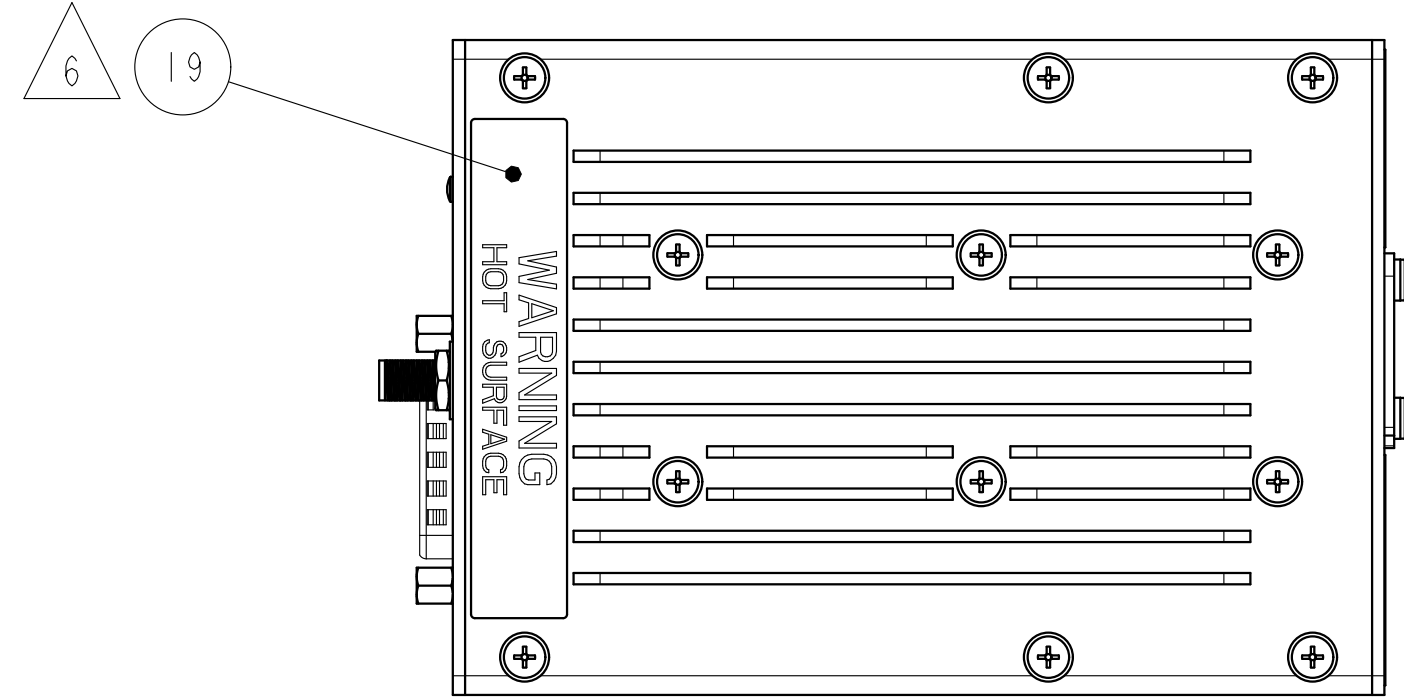

TABLE 1

FIND NO.	THREAD SIZE	TORQUE INCLUDES PREVAILING TORQUE VALUE ±.50 IN/LB
54	M2	2-3
36, 53, 55, 56, 57, 58	#4-40 UNC	5-6

SEE SEPARATE PARTS LIST

US GOVERNMENT DATA RIGHTS NONE		SIMILAR PART NO NA	DRAWING START DATE 2023-04-09	Green Lane, Ashchurch Tewkesbury, Glos GL20 8HD, UK	EMS SATCOM
EMS DATA RIGHTS HONEYWELL STANDARD PROPRIETARY		PROGRAM SMALL SATCOM	DESIGN N BOWYER 2023-04-09		
HONEYWELL PROPRIETARY- COPYWRITE 2023 BY EMS SATCOM UK, LTD (d/b/a HONEYWELL). ALL RIGHTS RESERVED. NO REPRODUCTION OR USE OF THIS MATERIAL MAY BE MADE WITHOUT HONEYWELL'S PRIOR WRITTEN PERMISSION.		MA WORK ORD/EWO/NETWORK ACTIVITY NO NA	CHECKER C LAM 2023-04-18	TITLE ASSEMBLY SMALL SATCOM, GEN6, INDOOR UNIT	
		SALES ORDER NUMBER NA	PROJECT SEE PDM		
	90411330-001		QUALITY SEE PDM		
	90411330-002	THIRD ANGLE PROJECTION	ANALYST NA		
	90412570-001		ELECTRONIC APPROVALS		
NEXT ASSY USED ON			INITIAL RELEASE: ECN-8207532 ALL APPROVALS CONTROLLED BY THE PRODUCT DATA MANAGEMENT SYSTEM CONTRACT NUMBER	SCALE: 2/1	WT: 1.30 LB MEAS
INITIAL APPLICATION			NA	SIZE D	CAGE CODE KF586
				DWG NO 90600736	REV B
				SHEET 1 OF 3	

PRODUCTION - Released - 05-Dec-2023 15:57:05 UTC

Downloaded By: Hisham, Stephen, 05 Dec 2023 15:57:05 UTC. The report classification (H/E/C/T/E/C) in this watermark supersedes any other classification. Document is restricted per applicable export laws.