

2595MHz

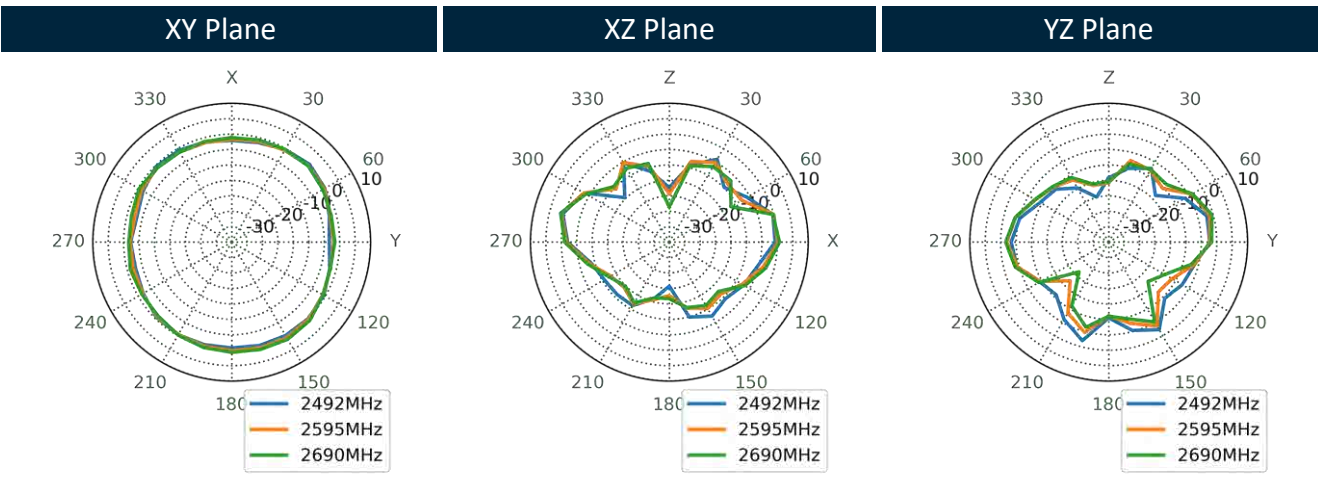

3550MHz

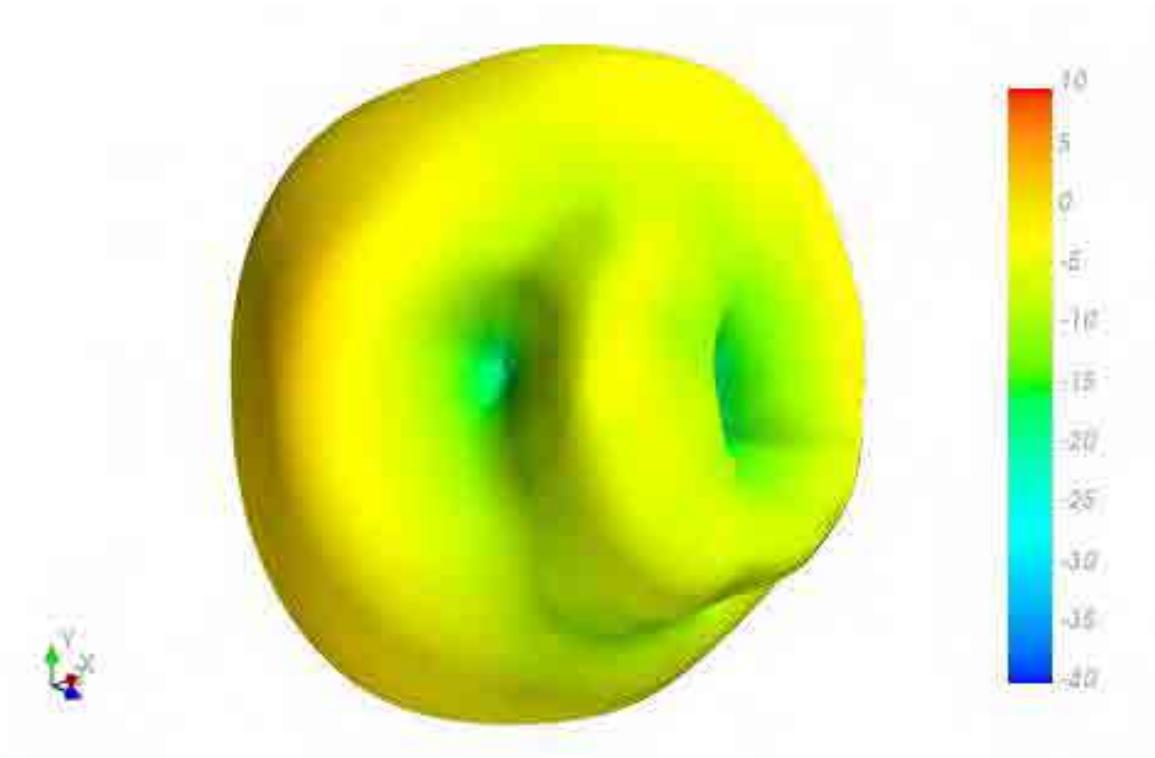
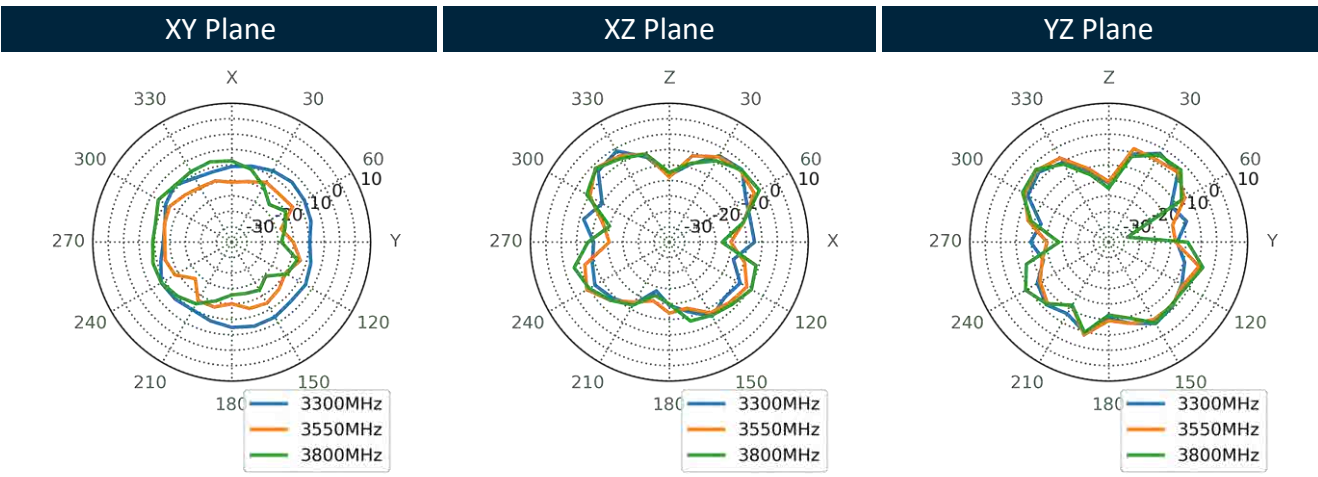
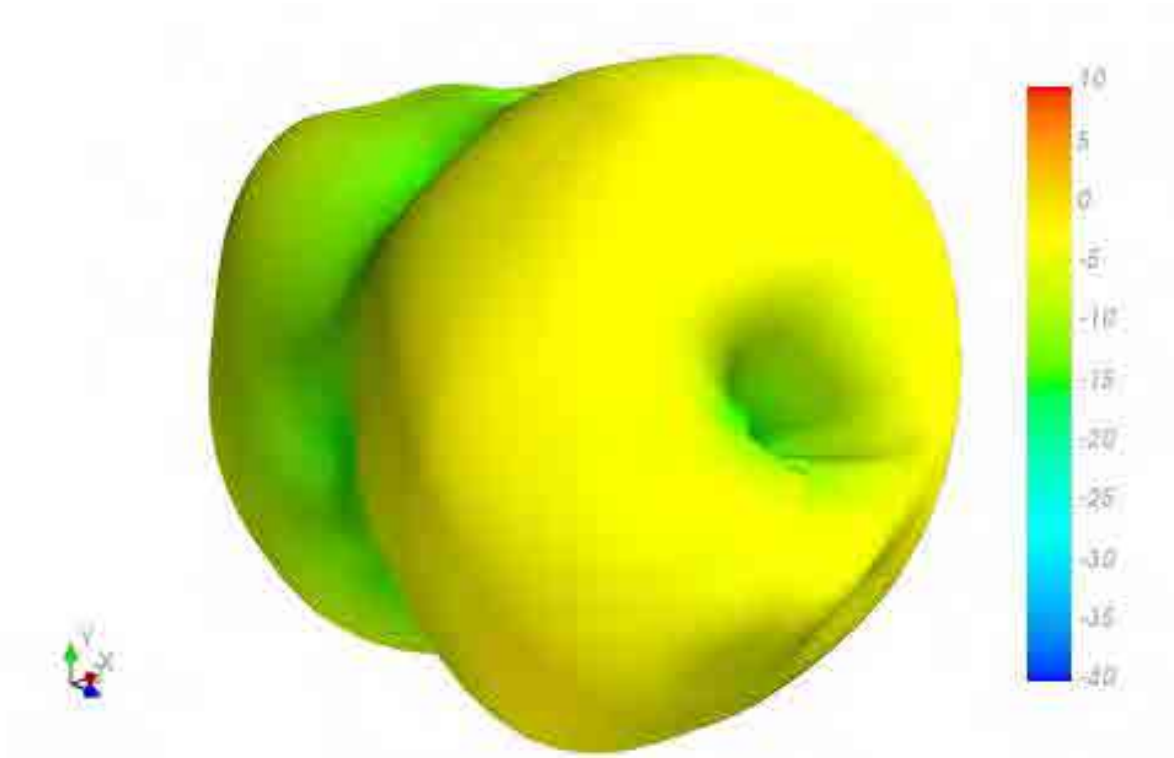

5530MHz

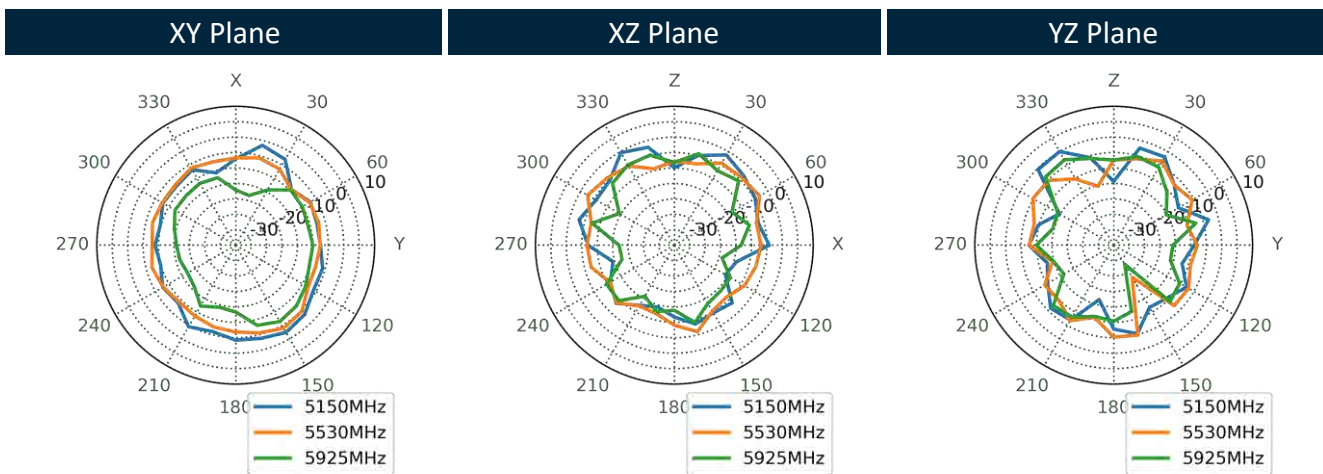
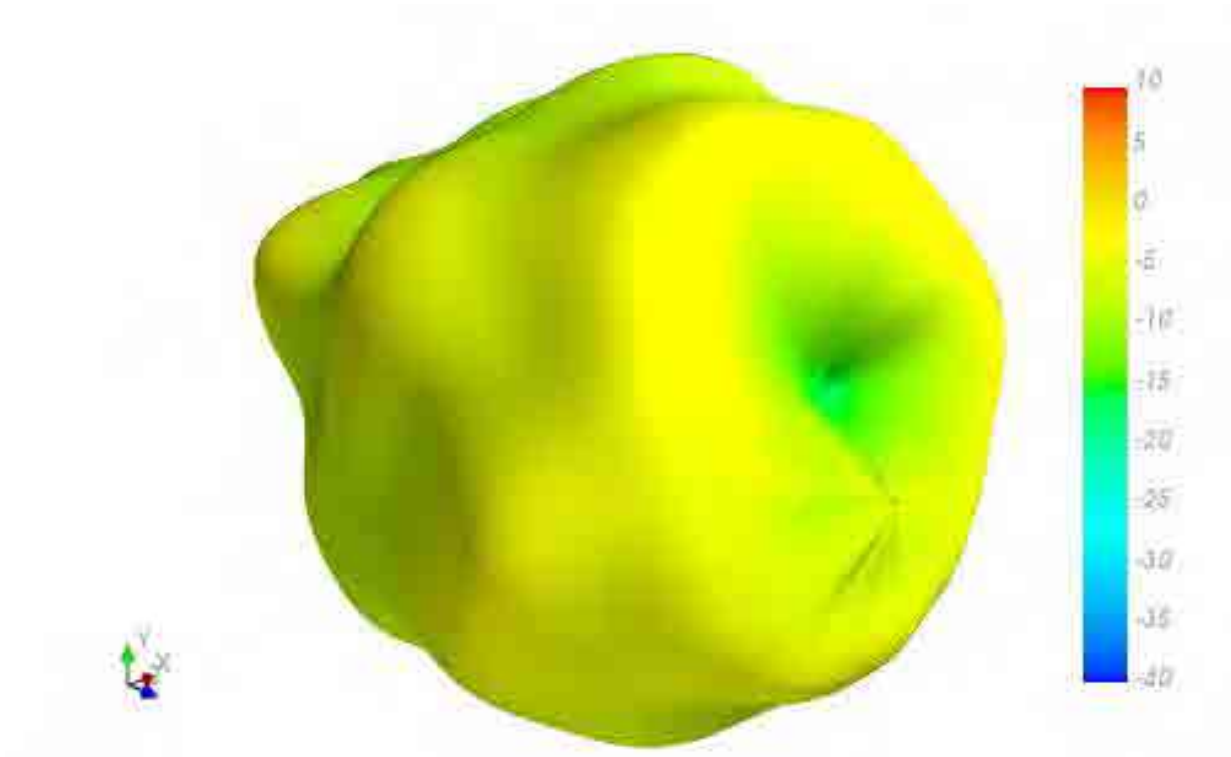

4.7 Test Setup

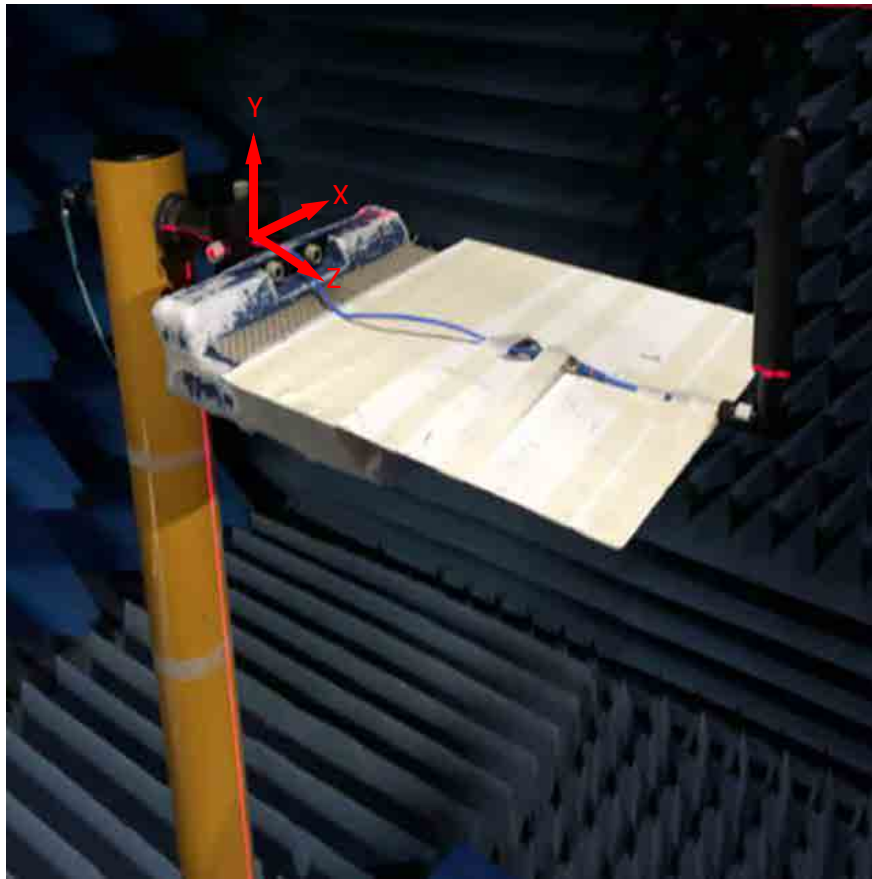

Bent 30x30cm Ground Plane Edge

4.8 Bent 30x30cm Ground Plane Edge 2D & 3D Radiation Patterns

652MHz

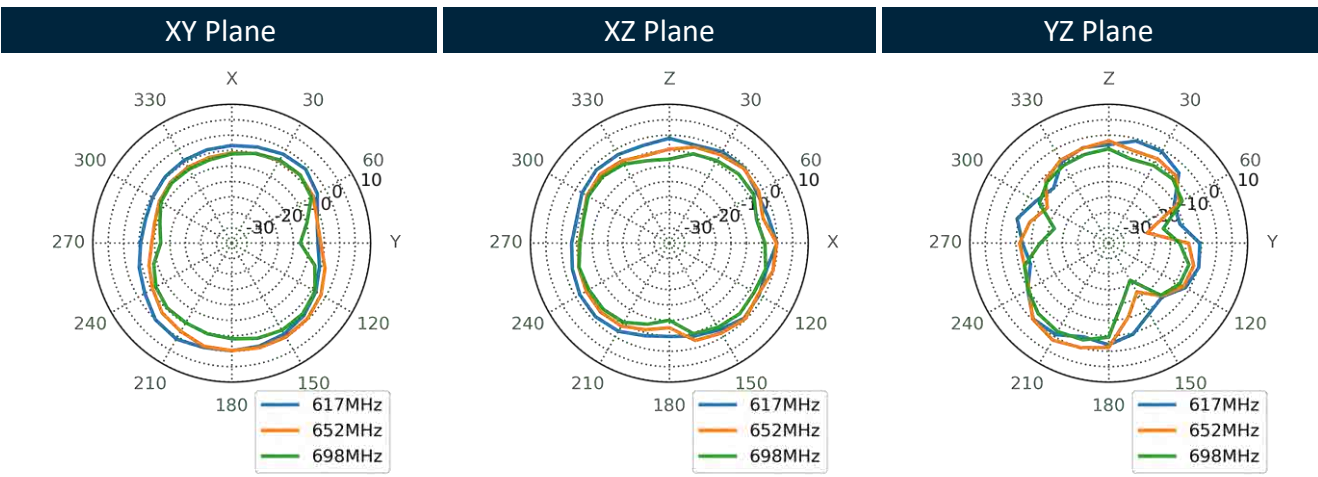
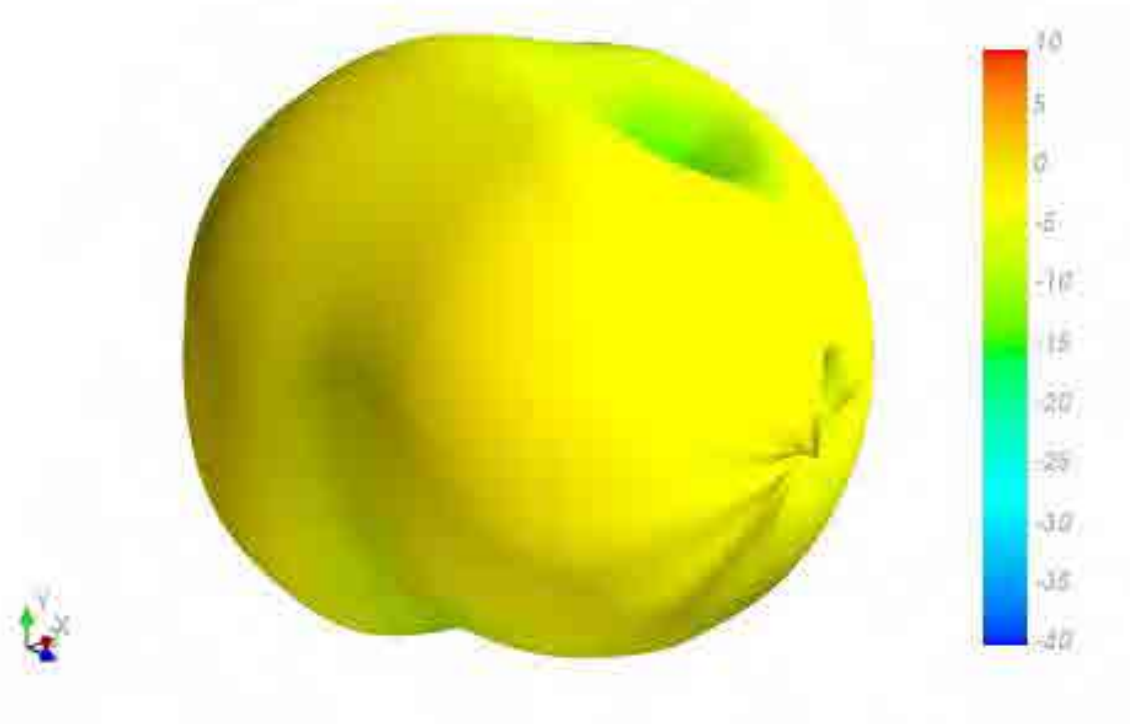

751MHz



XY Plane

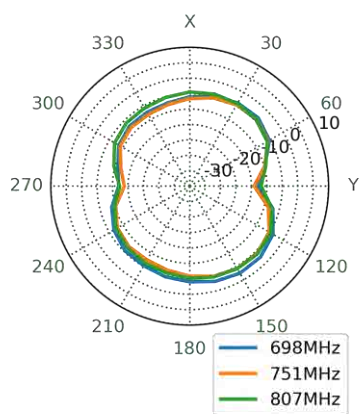

XZ Plane

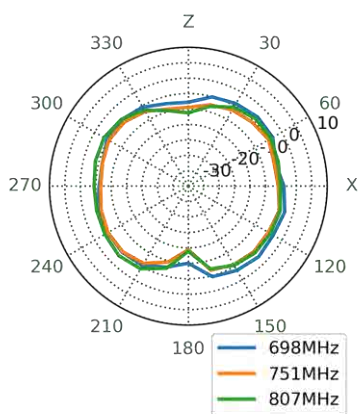

YZ Plane

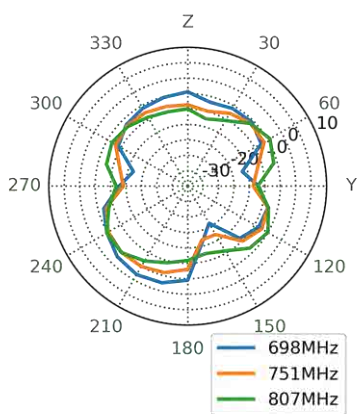

890MHz

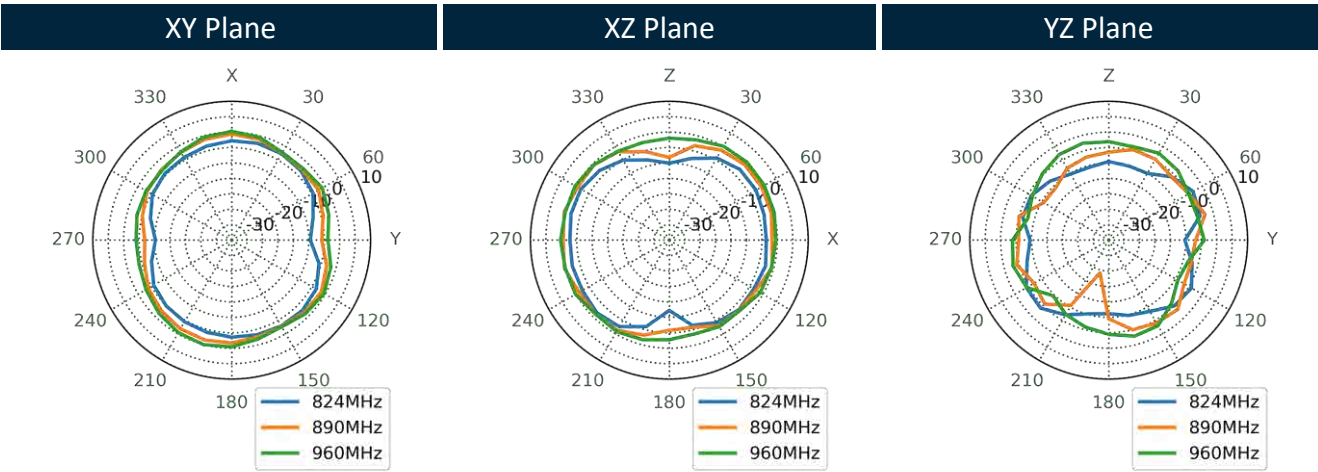
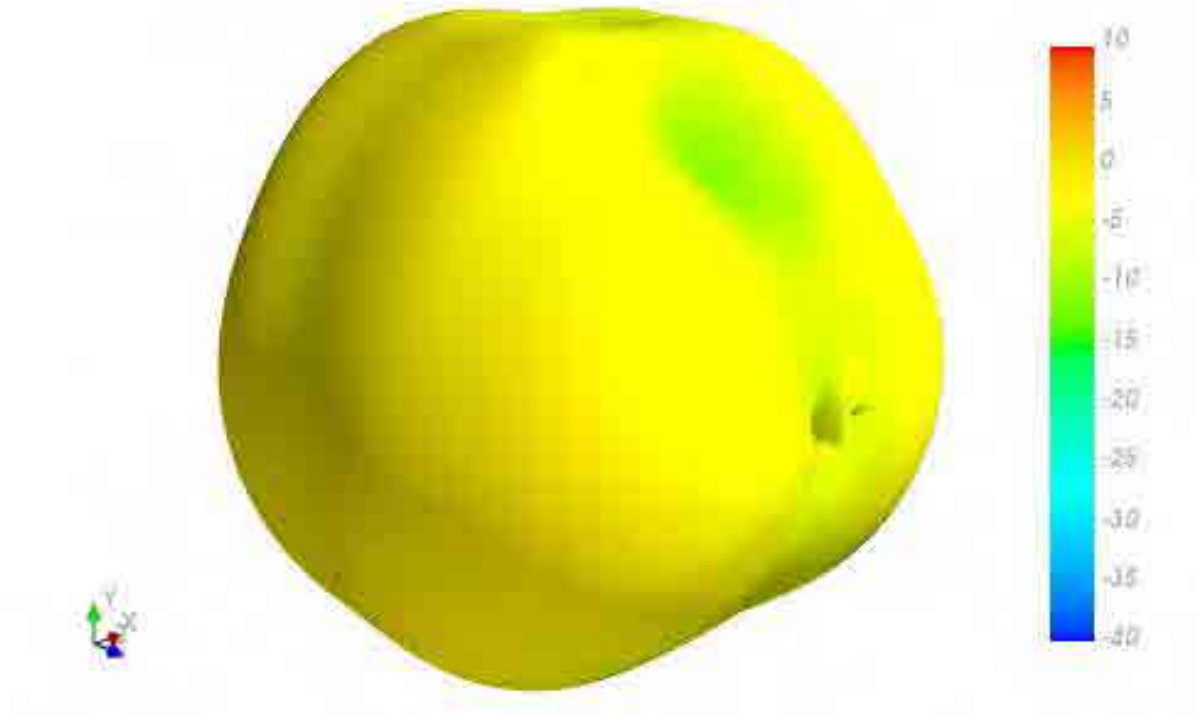



1470MHz

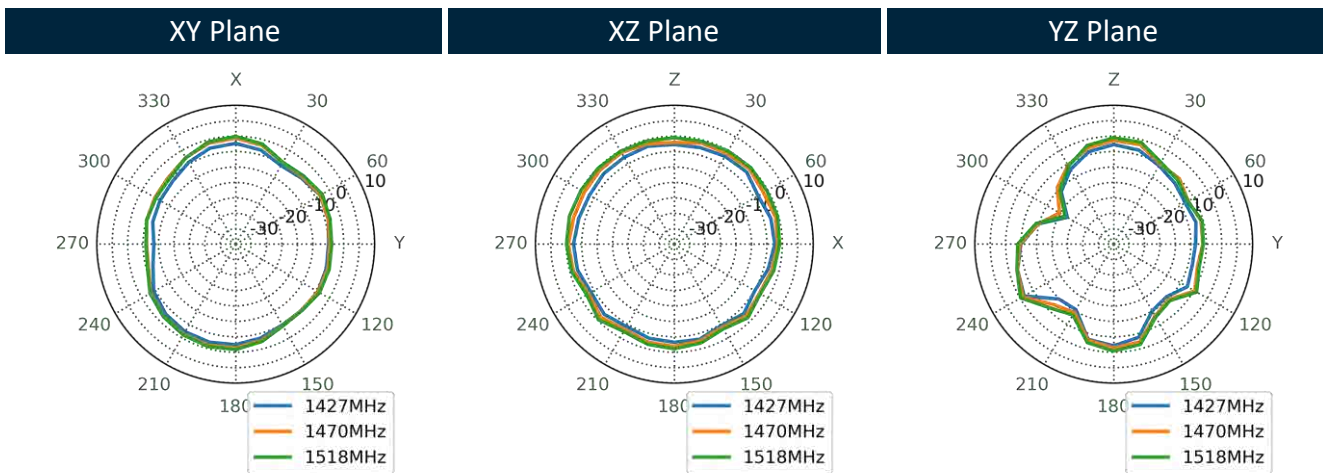
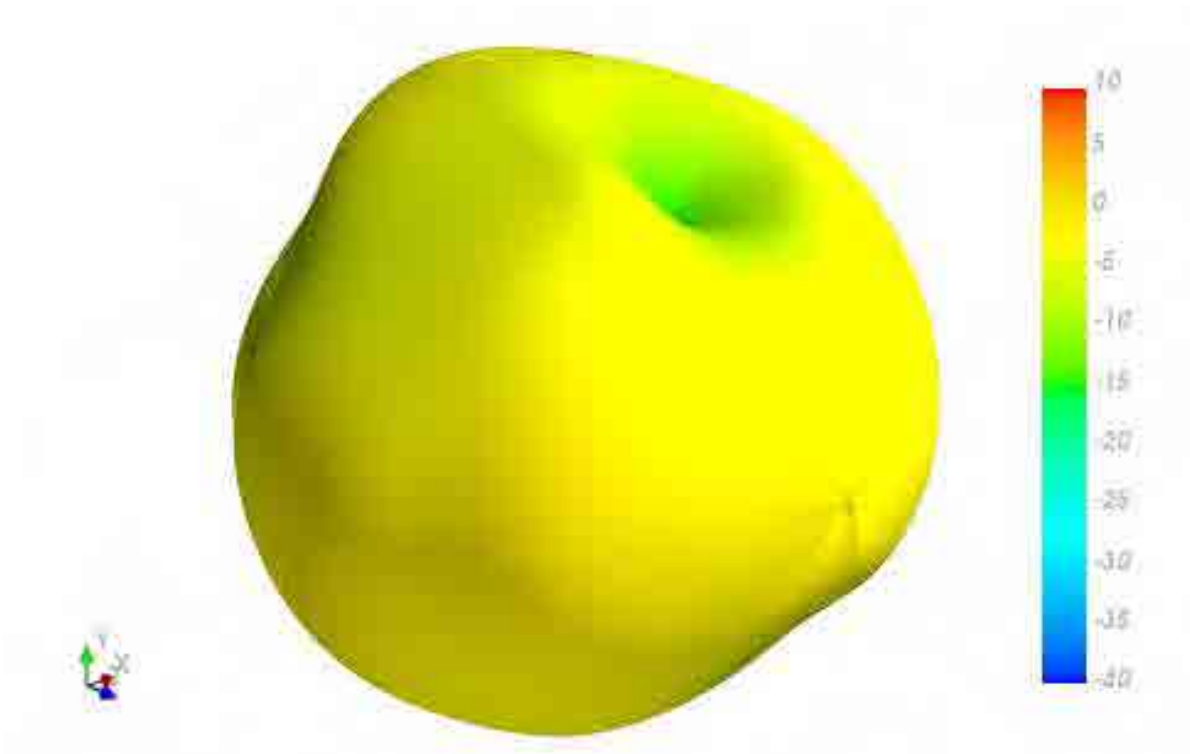



1805MHz

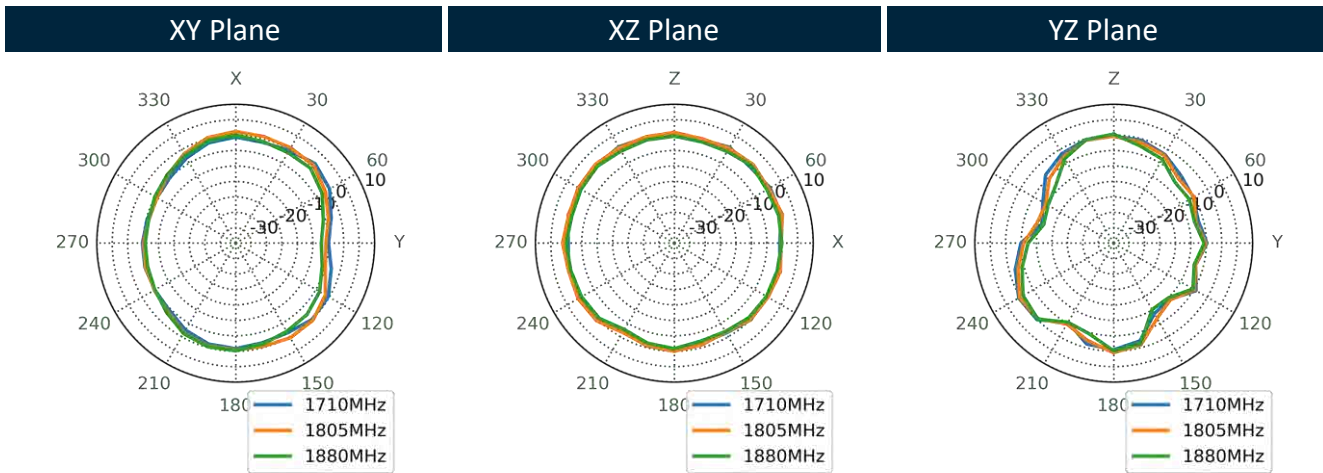
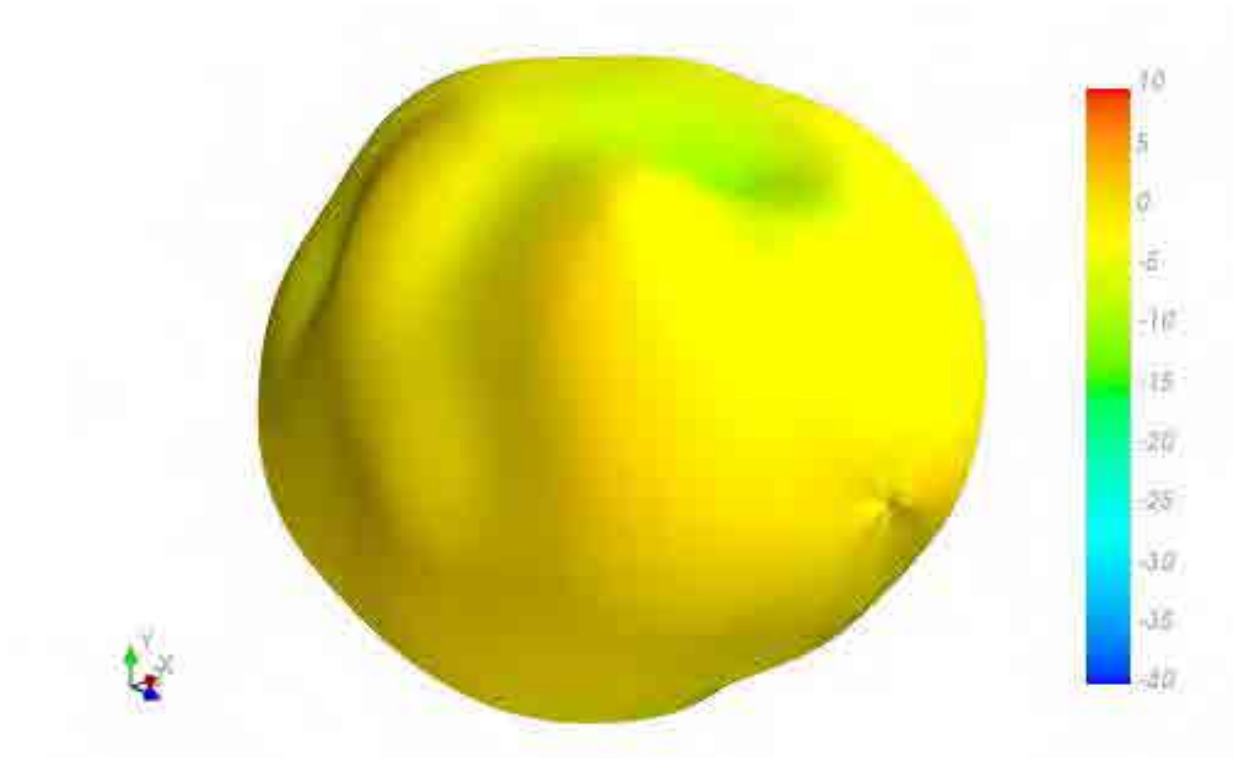

1920MHz

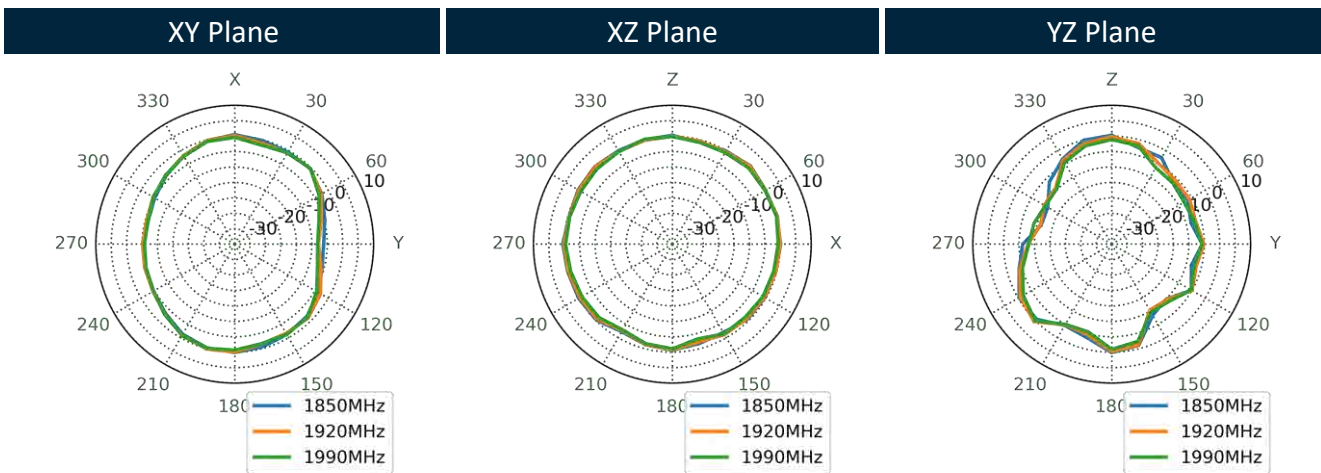
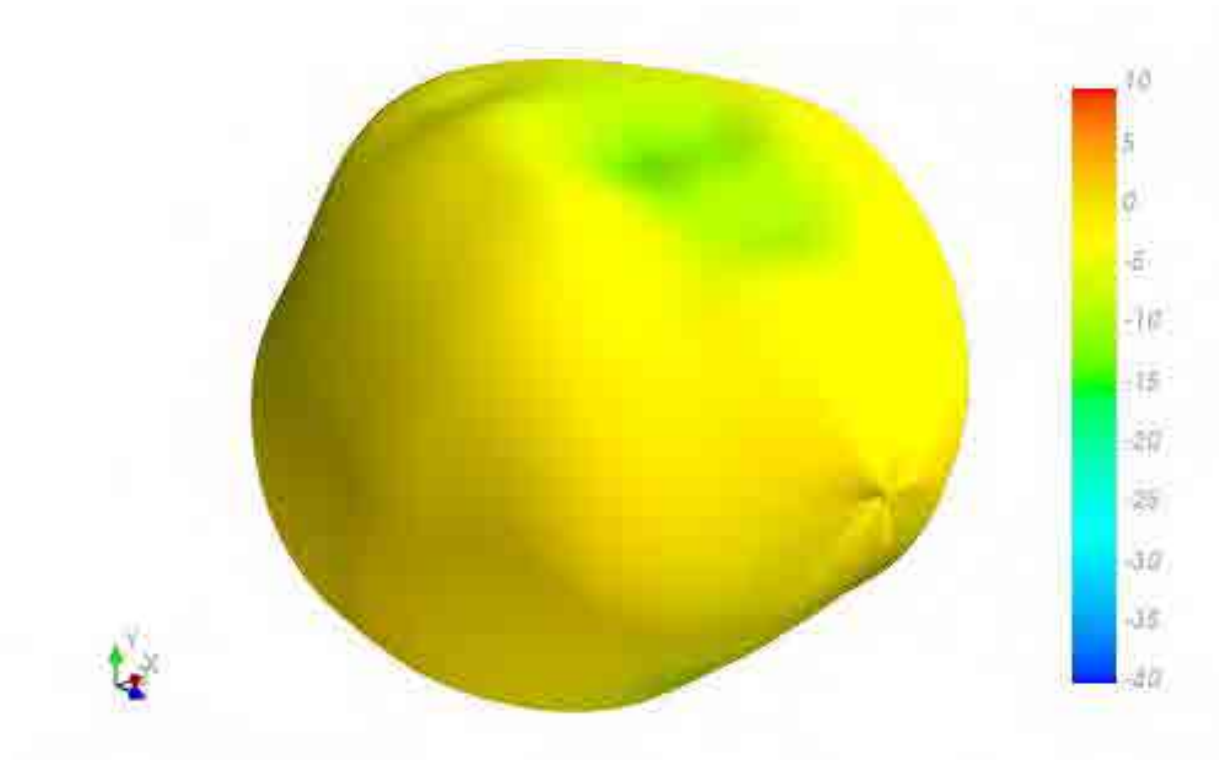

1990MHz

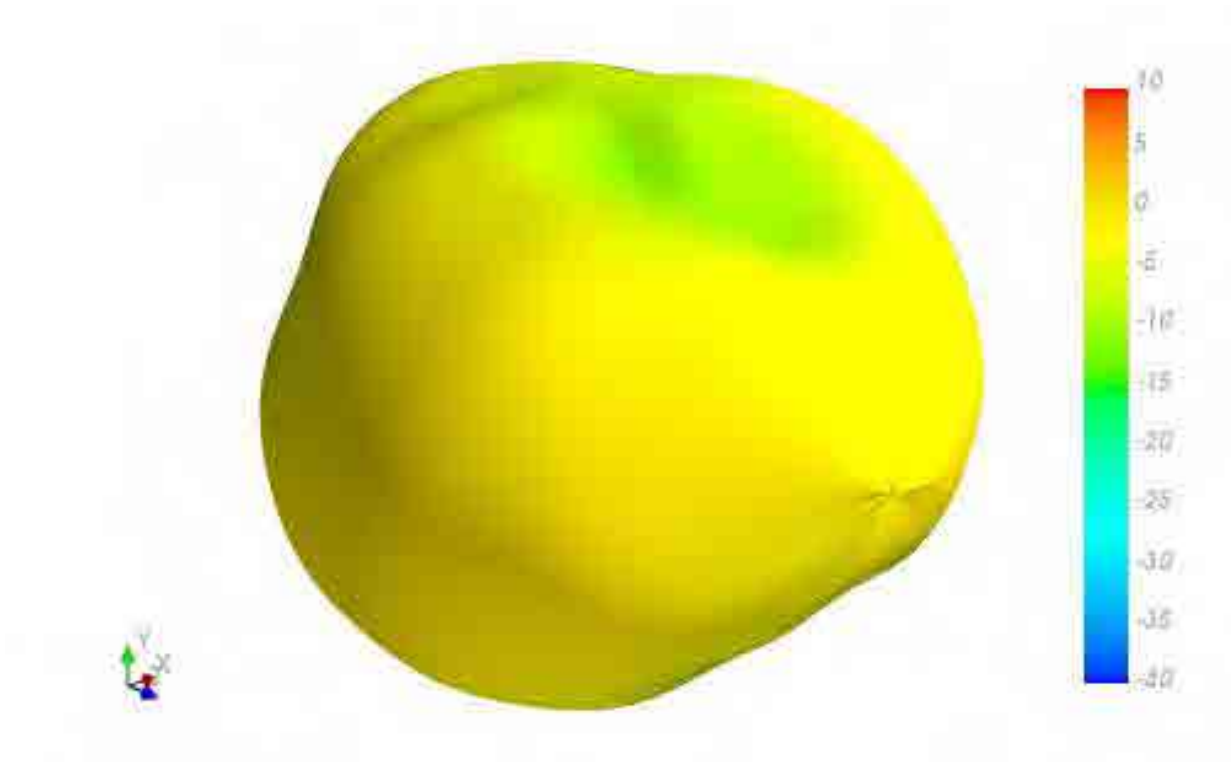

XY Plane      XZ Plane      YZ Plane

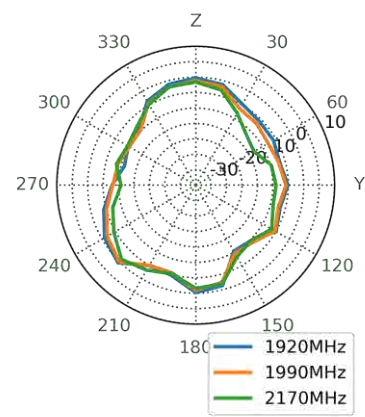
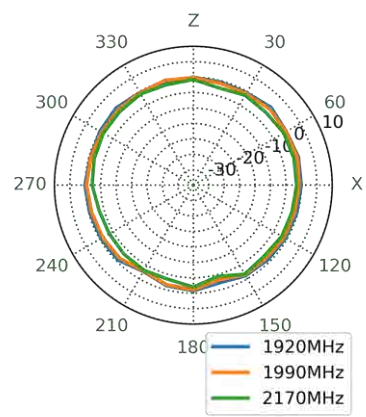
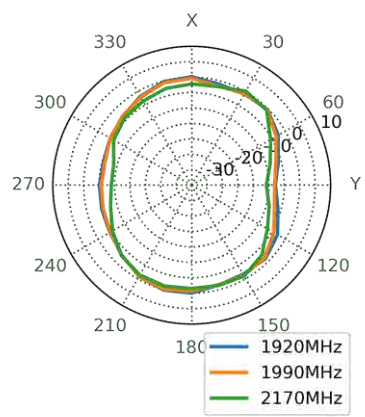

2595MHz

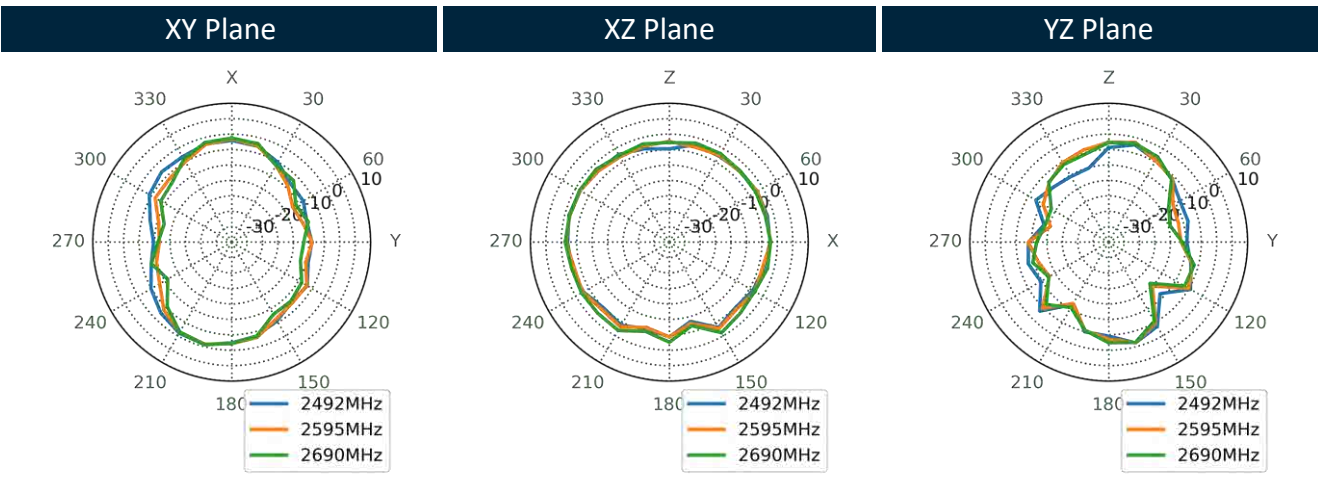
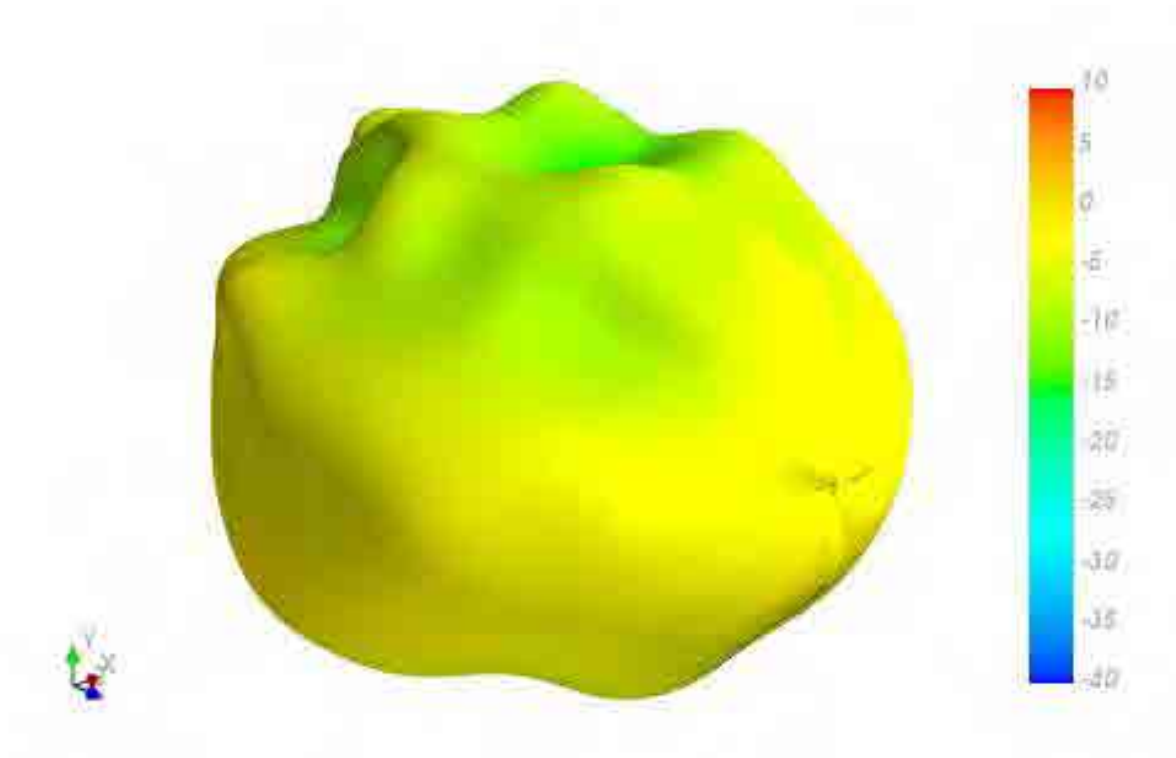

3550MHz

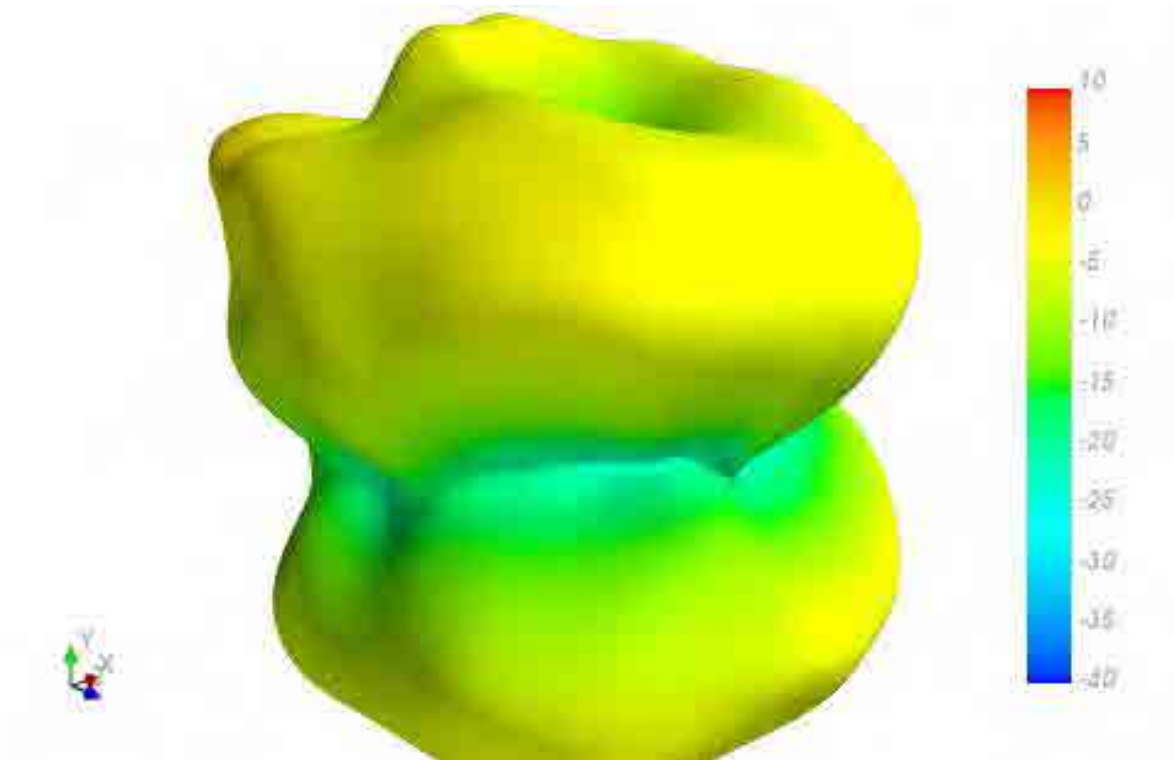

XY Plane

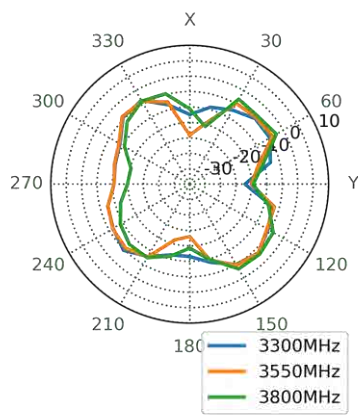

XZ Plane

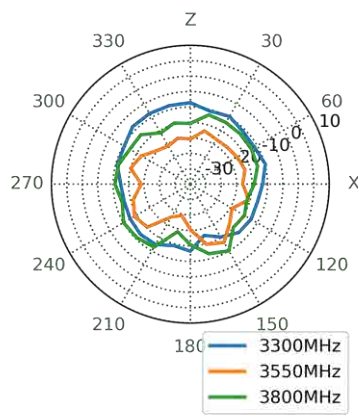

YZ Plane

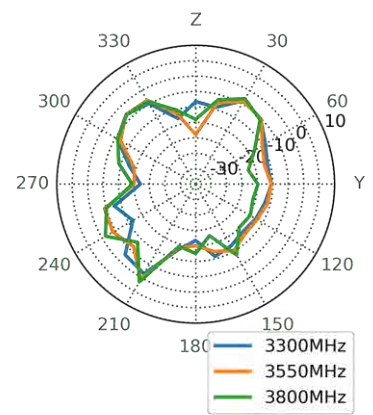

5530MHz

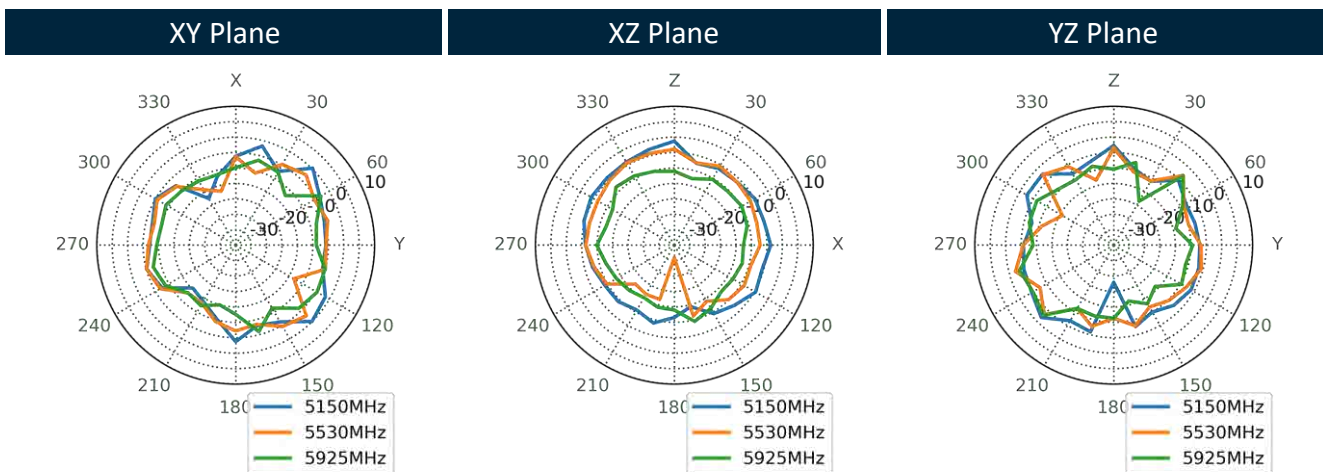
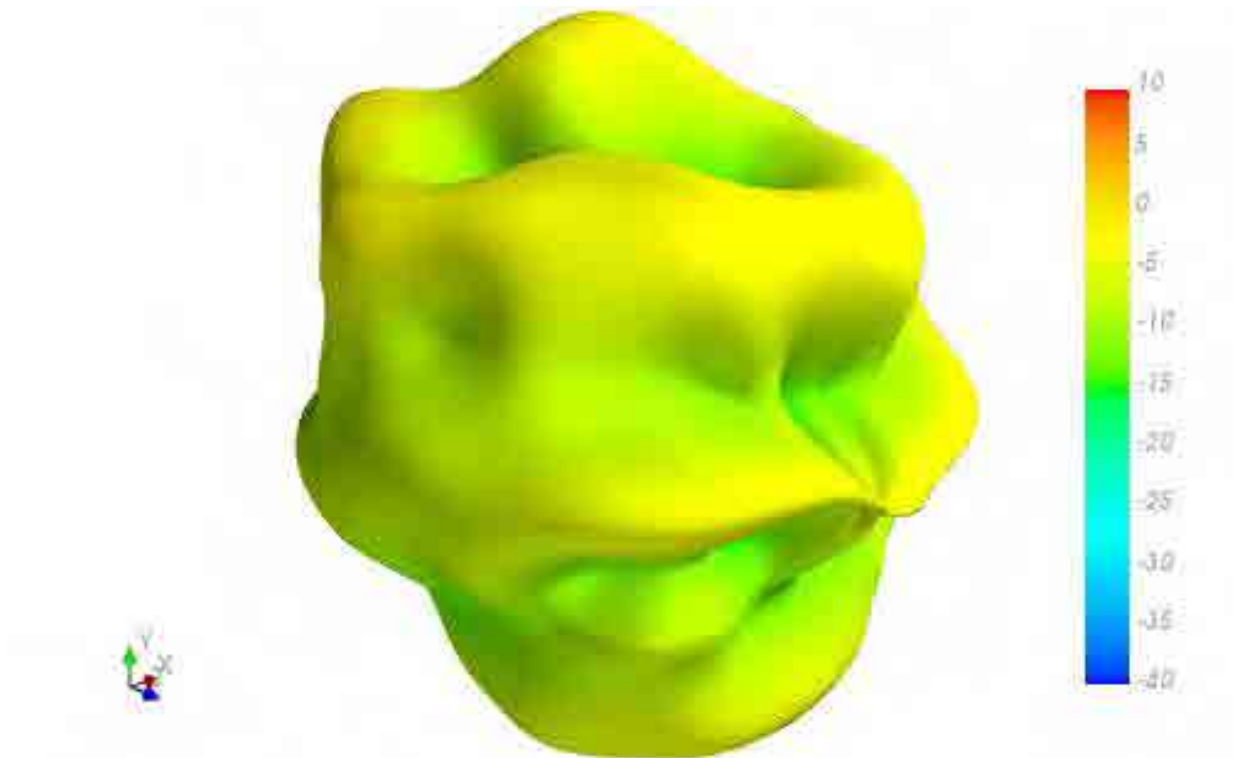

4.9 Test Setup

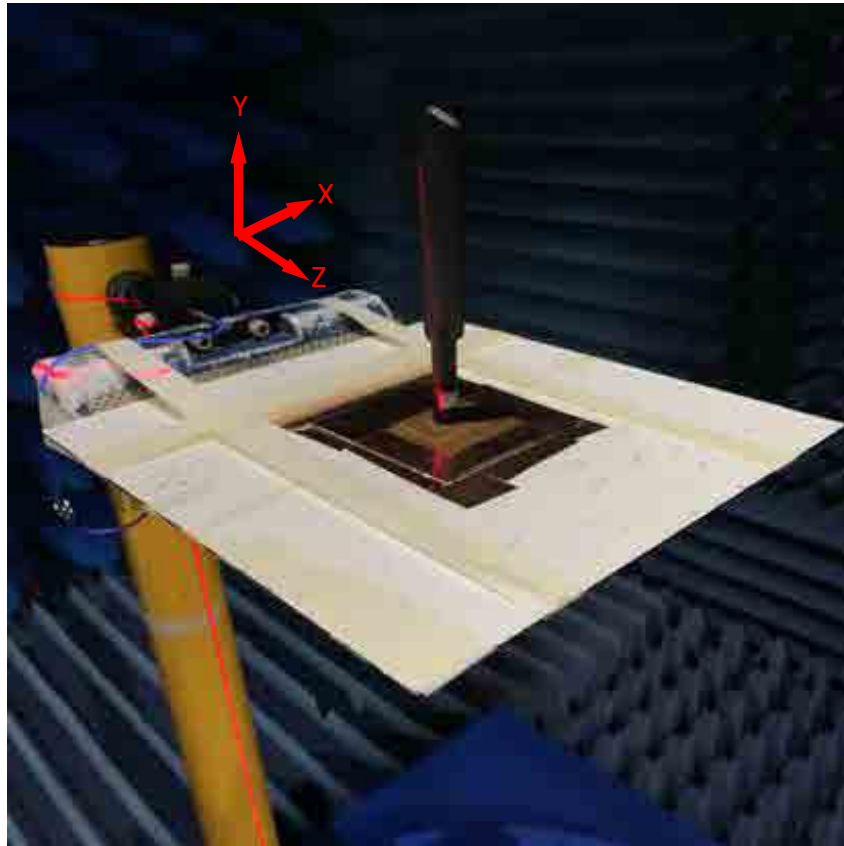

Straight 30x30cm Ground Plane Centre



## 4.10 Straight 30x30cm Ground Plane Centre 2D & 3D Radiation Patterns

652MHz

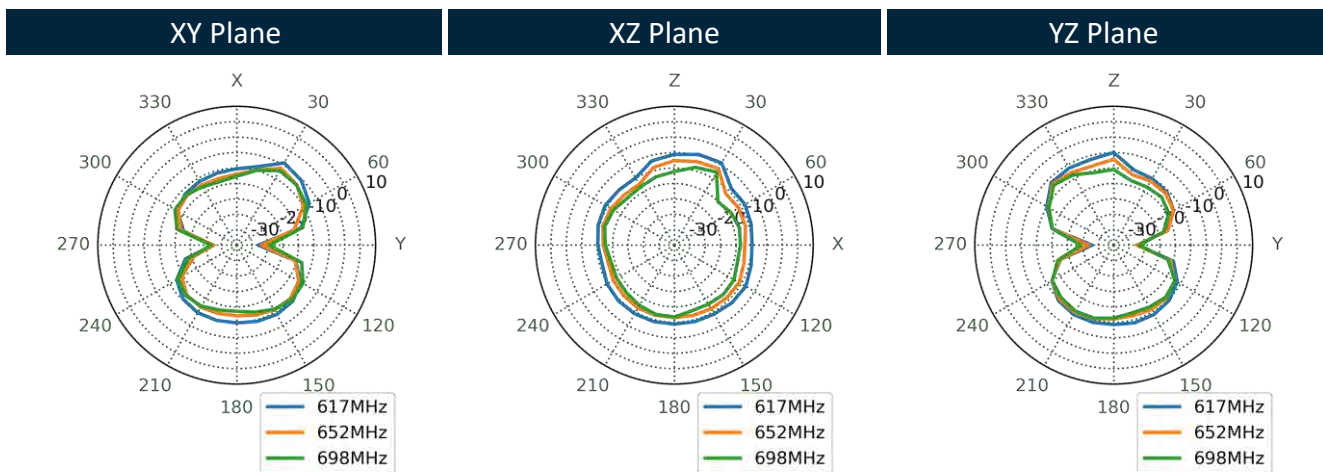

751MHz

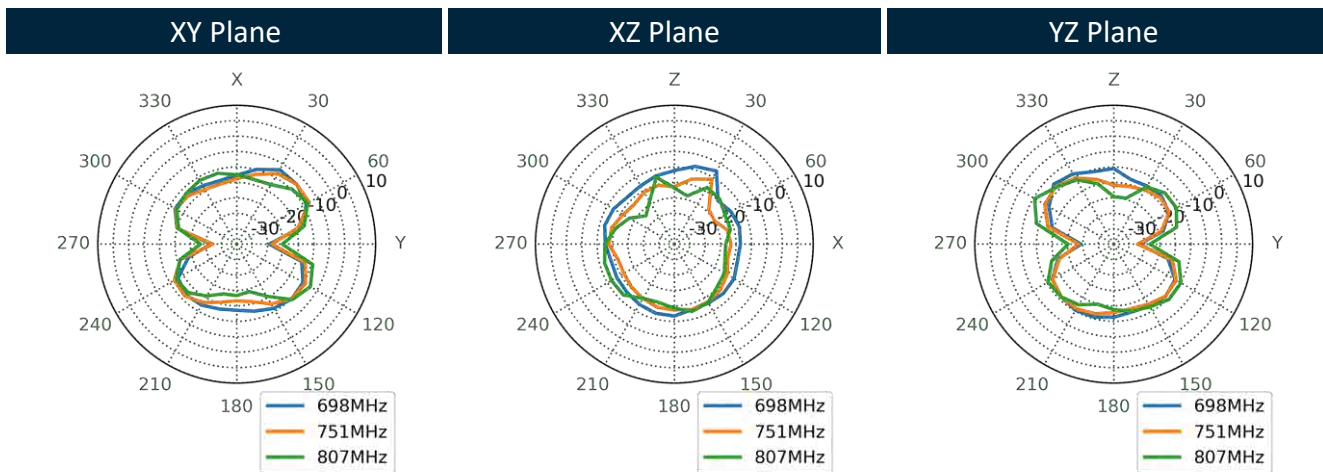
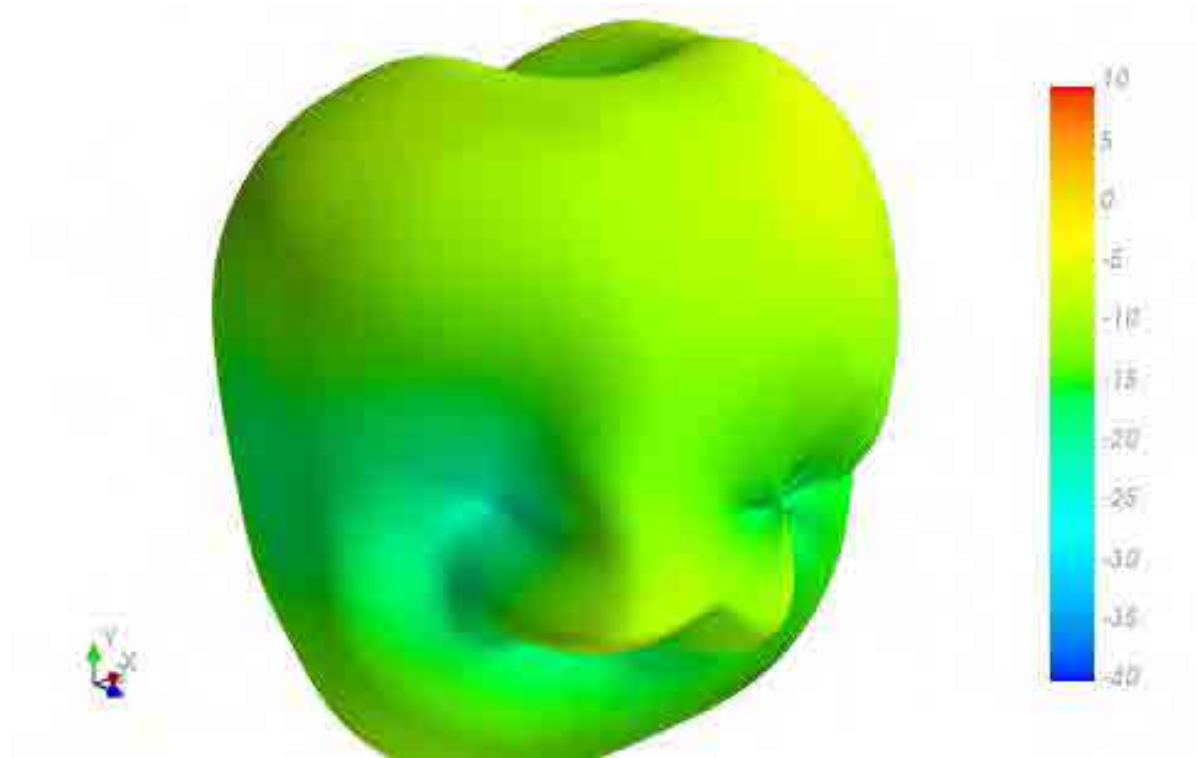

890MHz

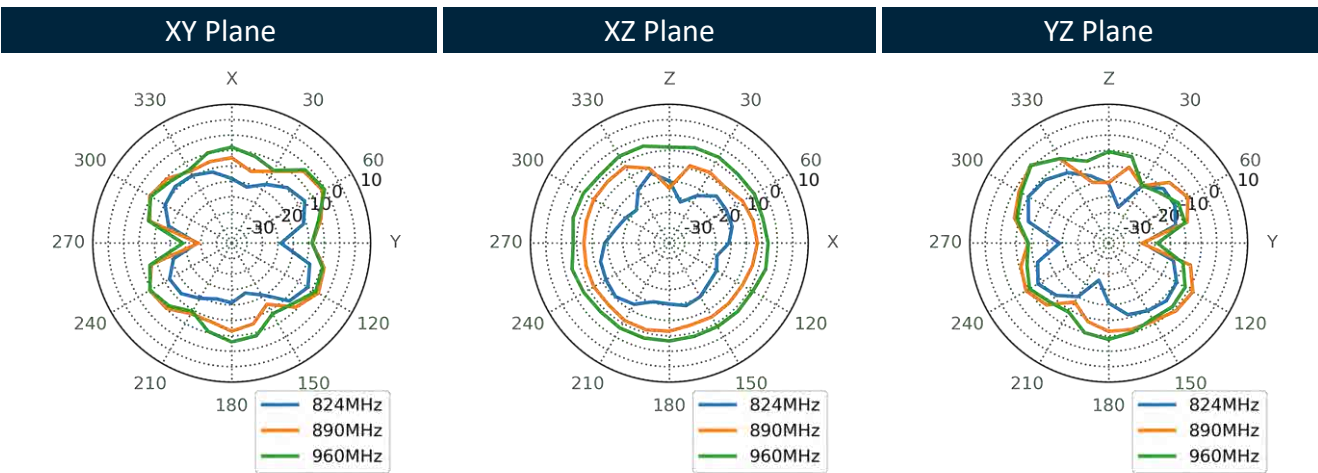
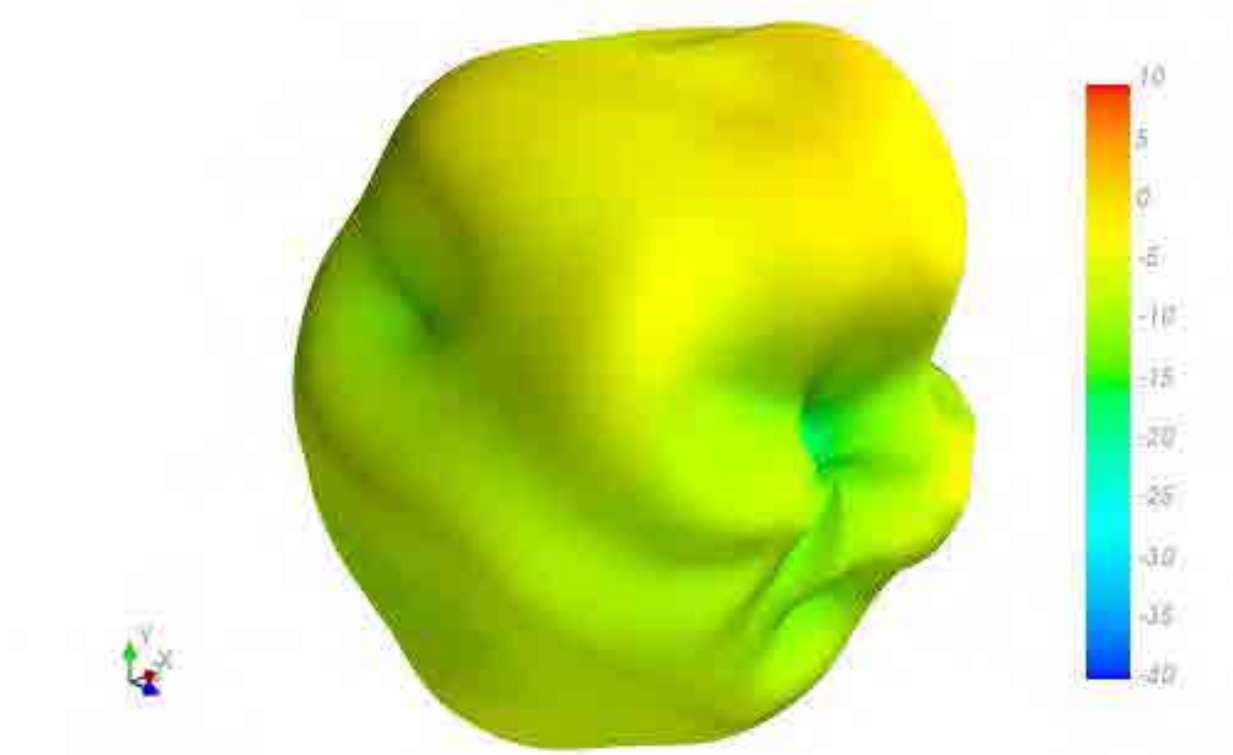

1470MHz

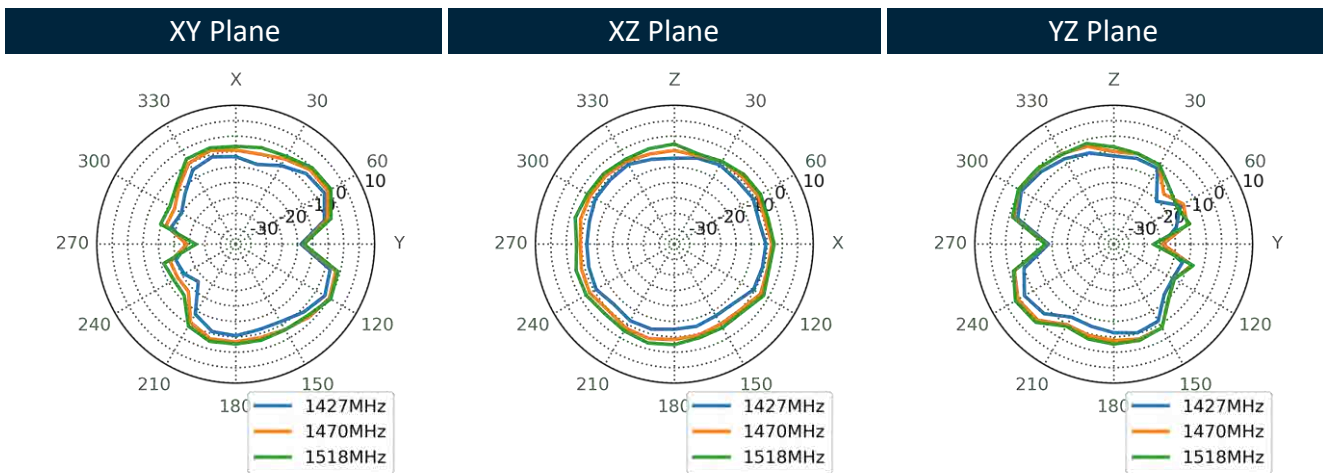
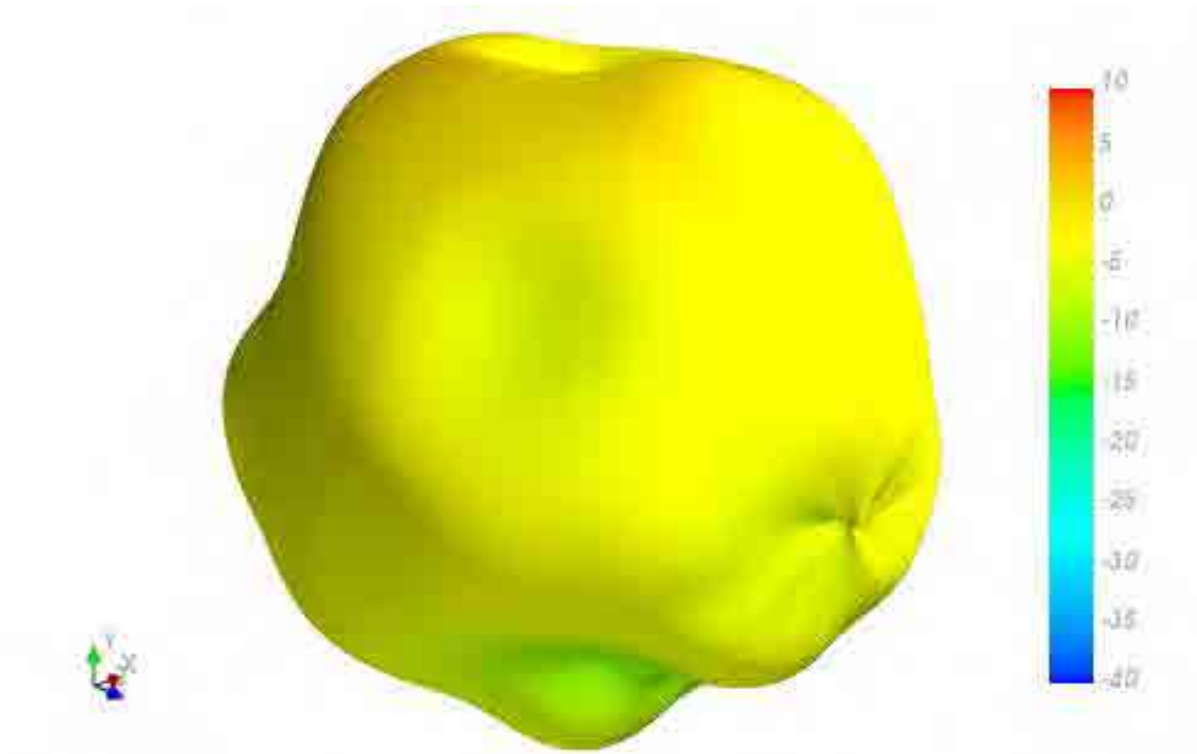

1805MHz

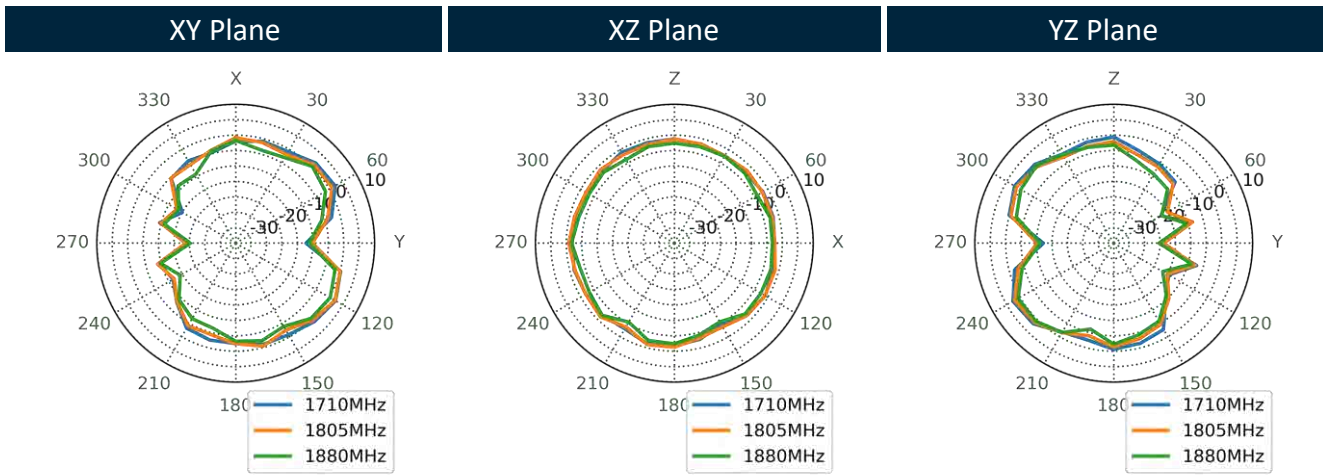
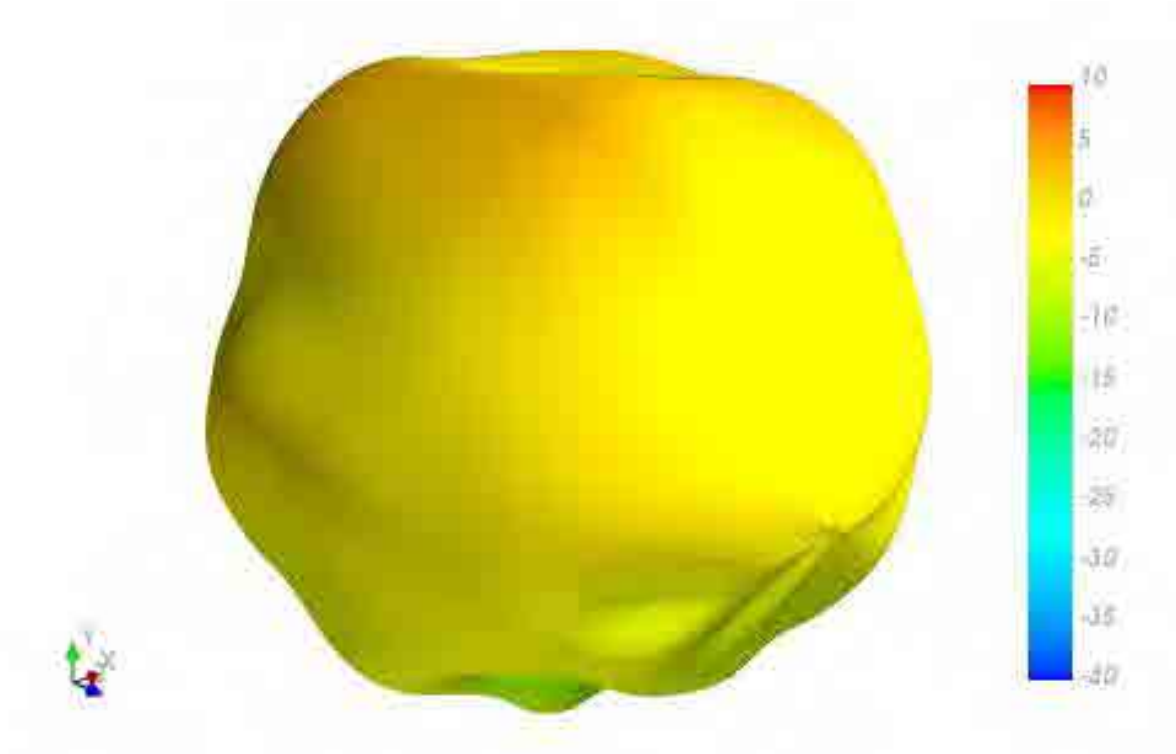

1920MHz

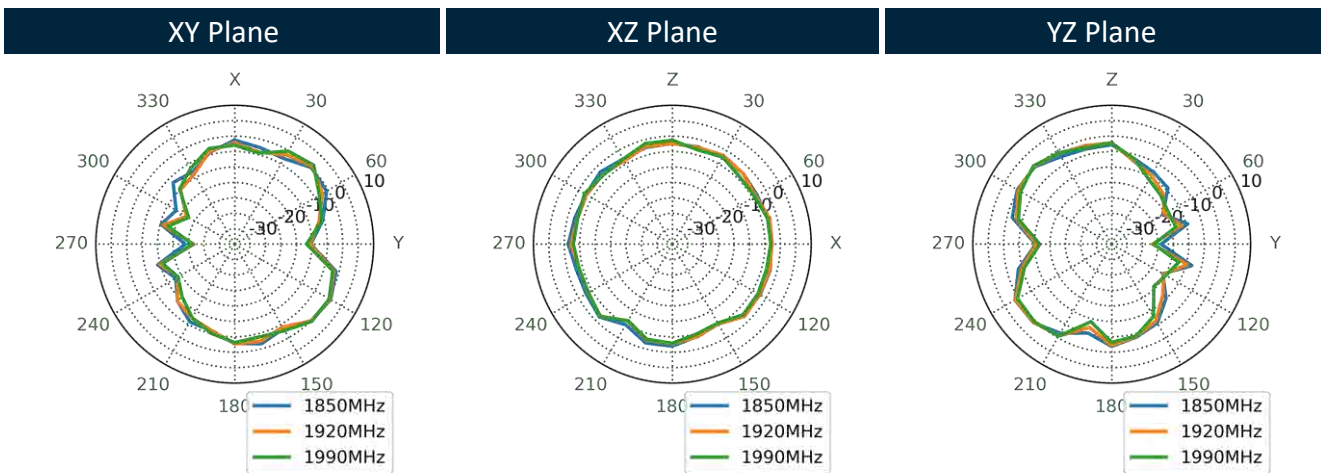
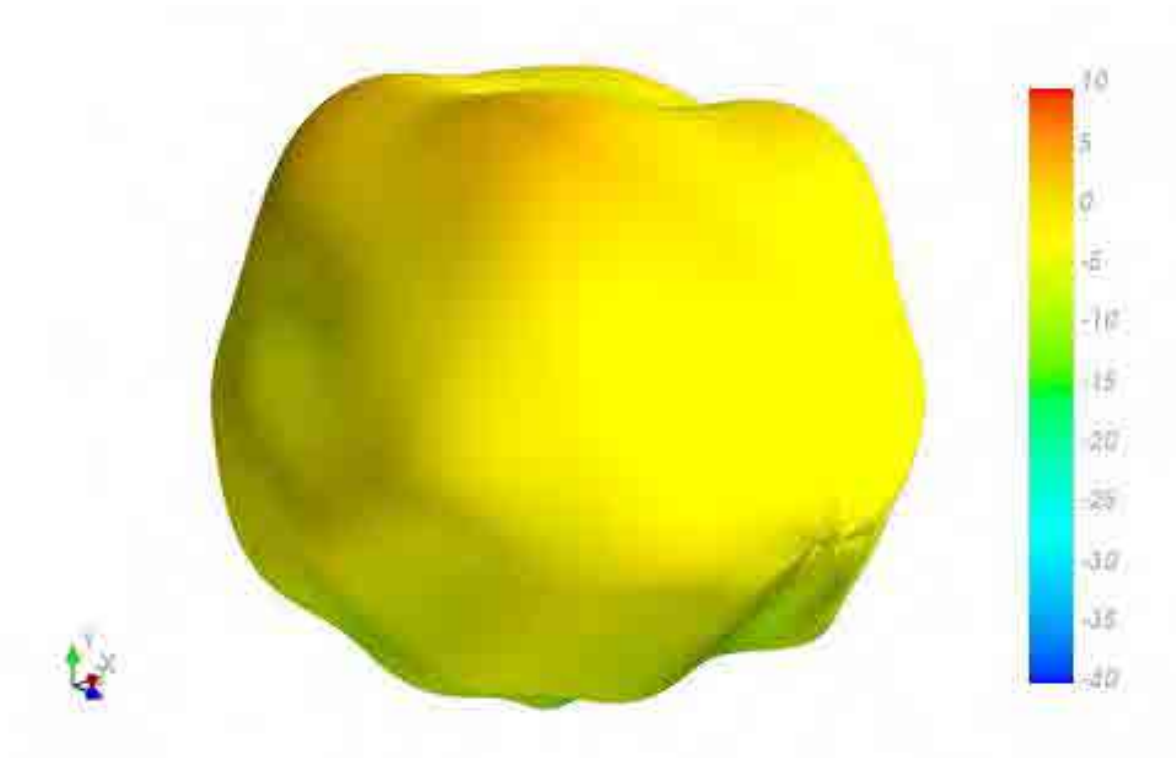

1990MHz

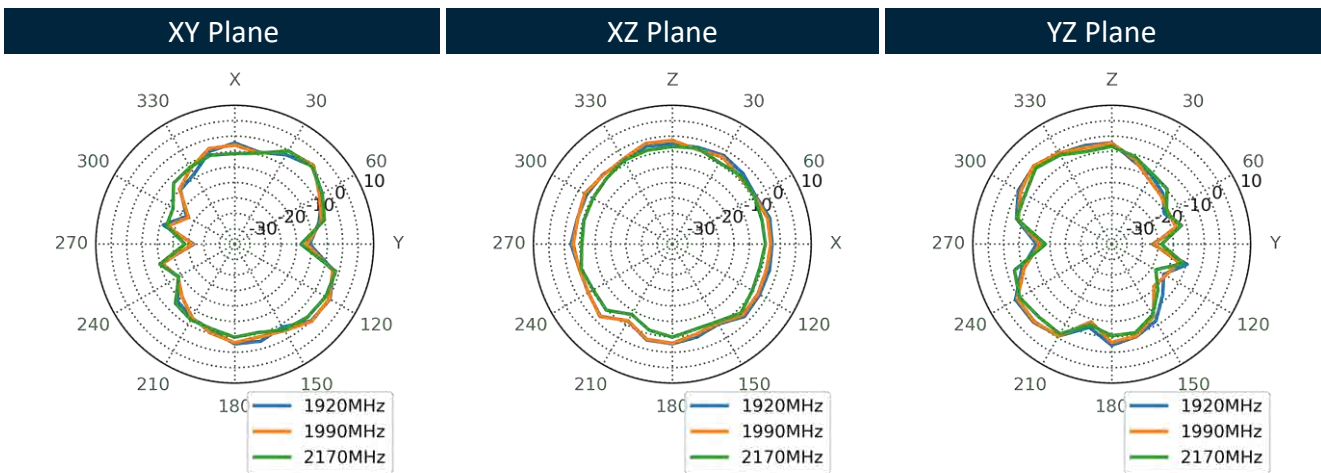
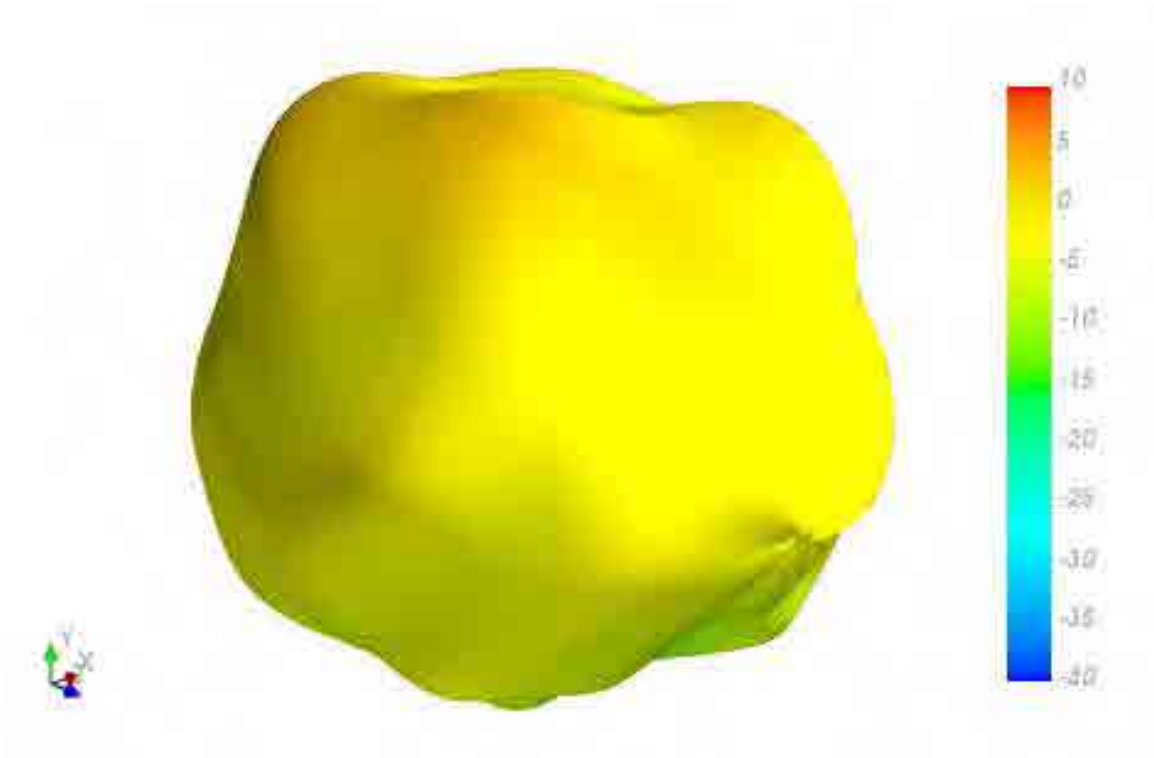



2595MHz

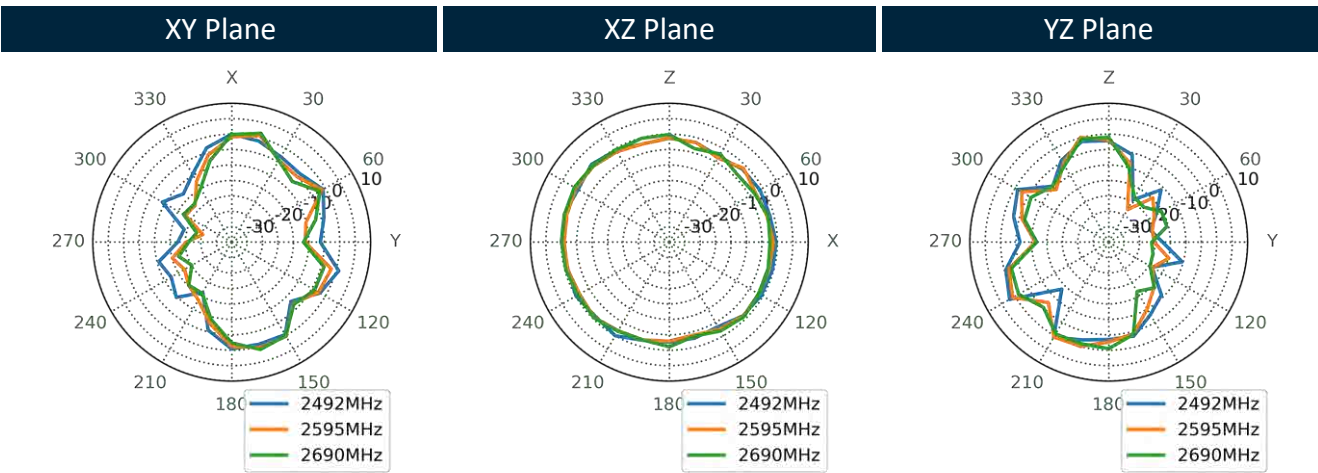
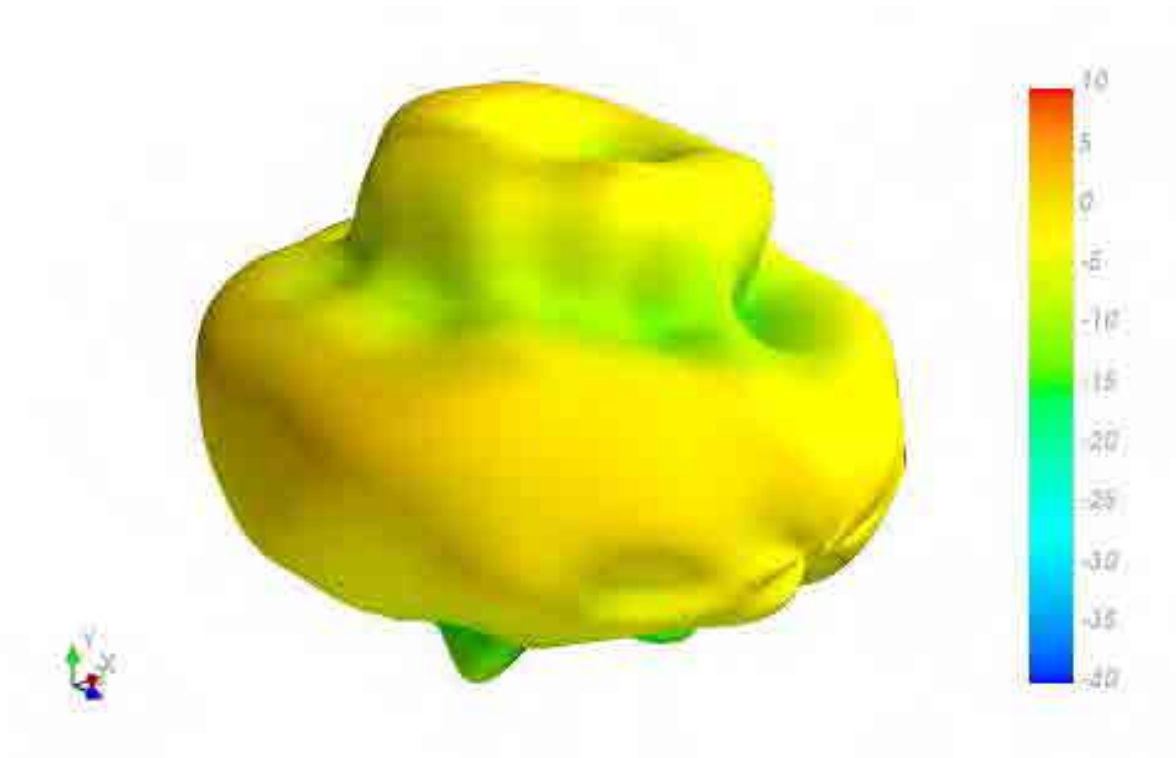

3550MHz

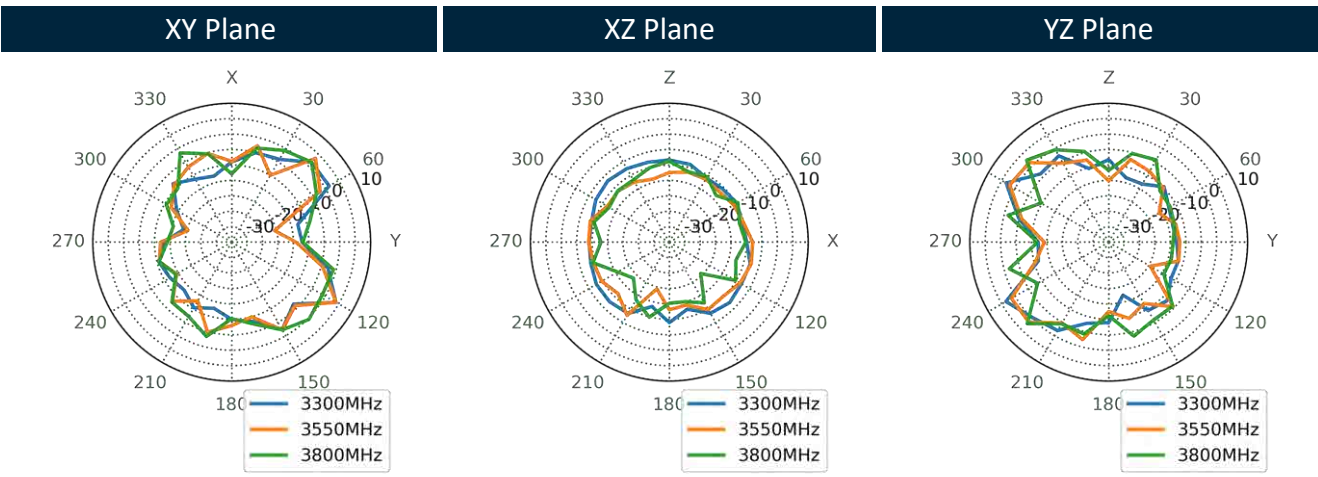
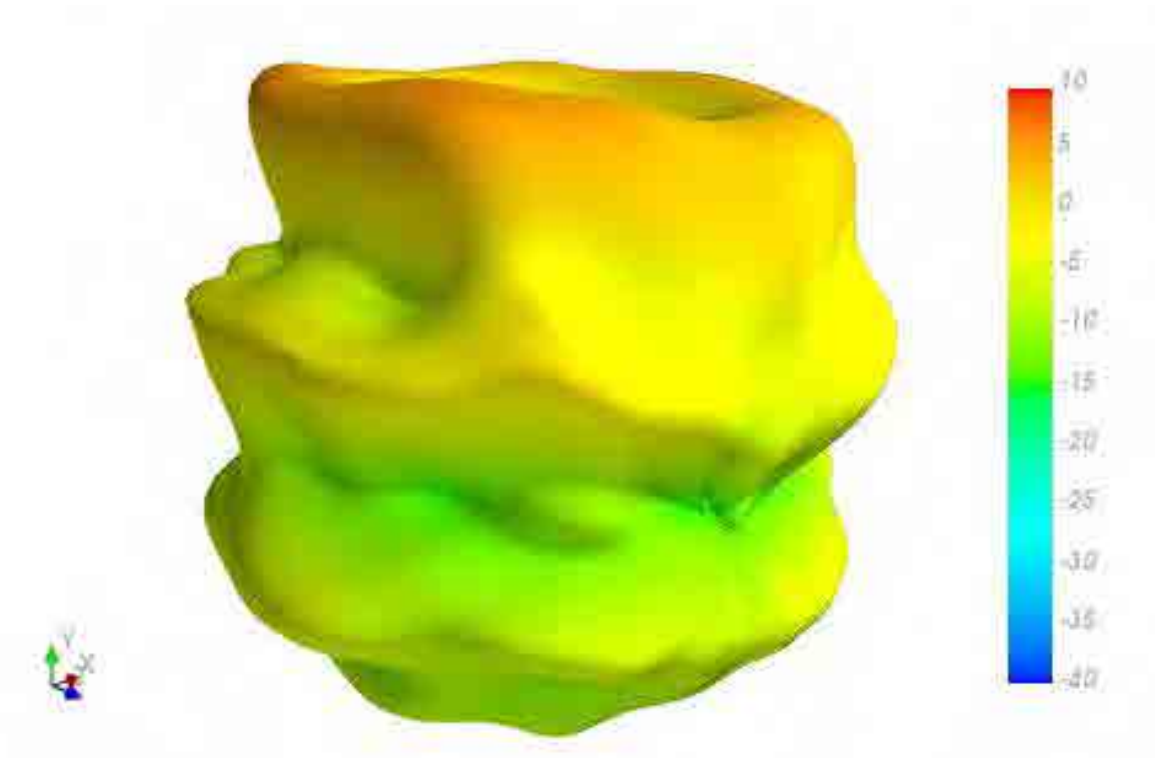

5530MHz

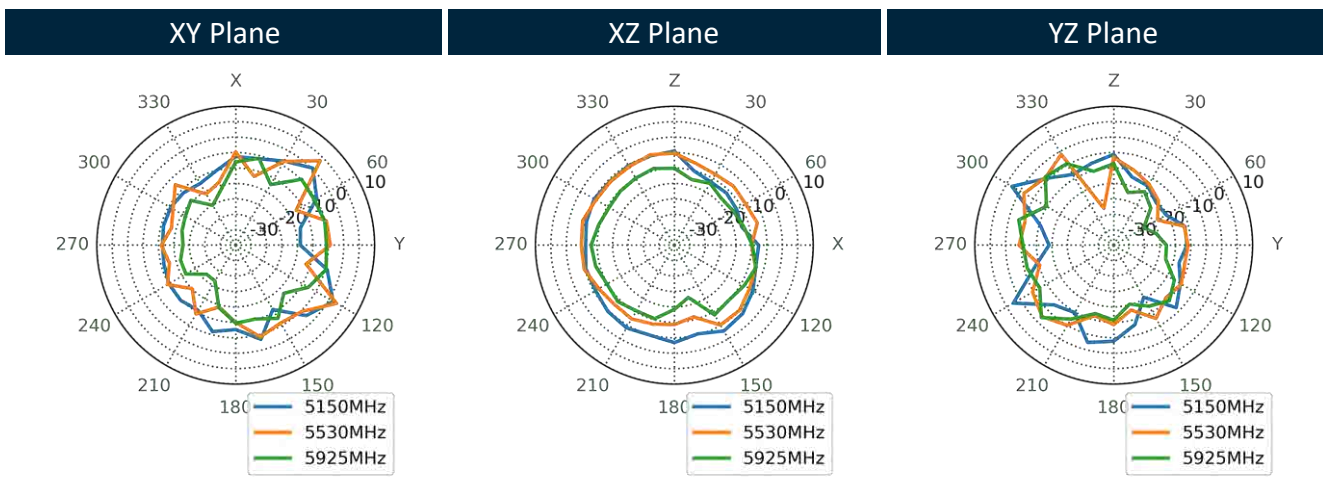
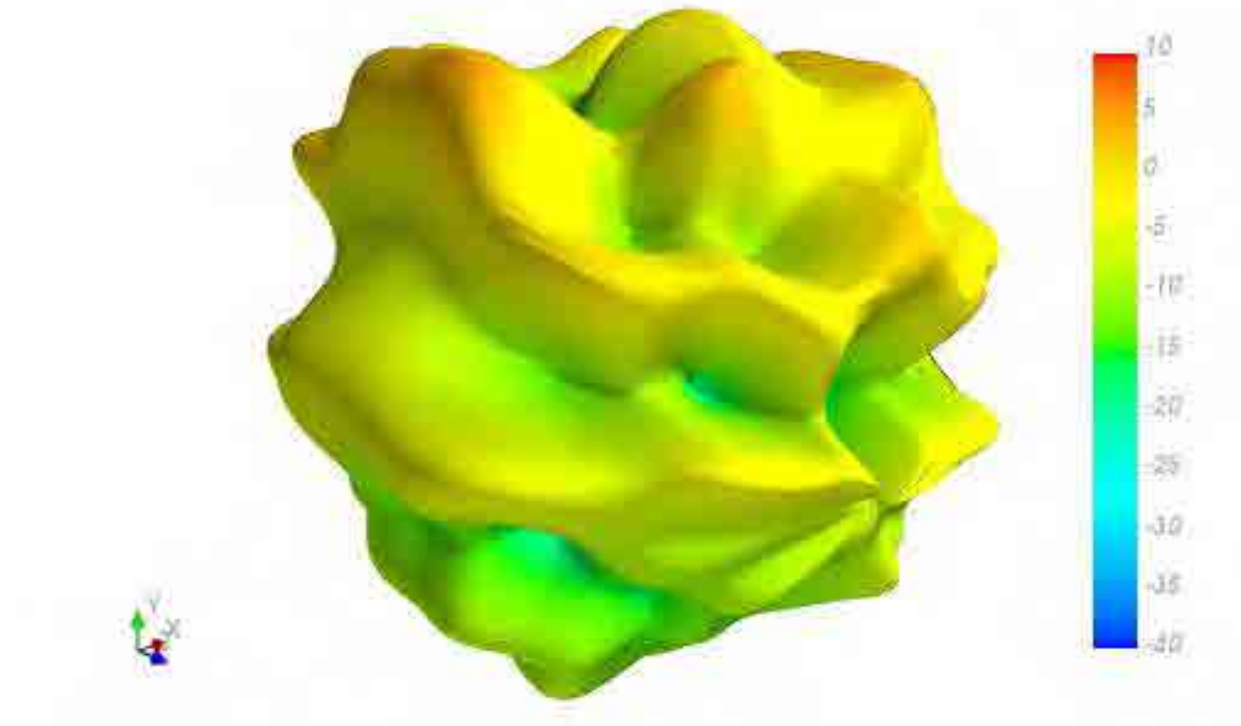

4.11 Test Setup

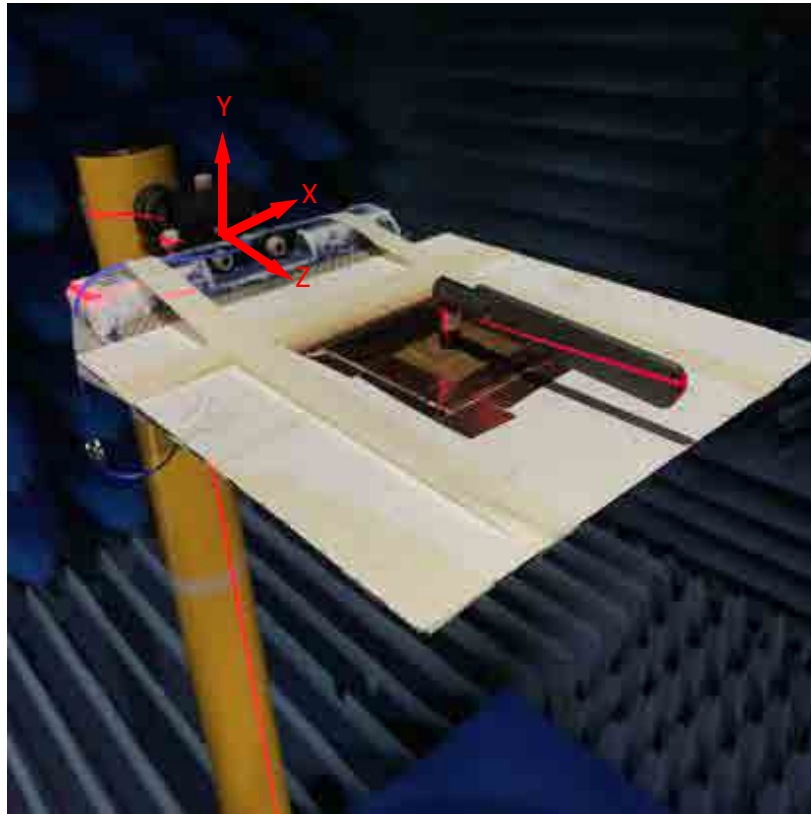

Bent 30x30cm Ground Plane Centre

## 4.12 Bent 30x30cm Ground Plane Centre 2D & 3D Radiation Patterns

652MHz

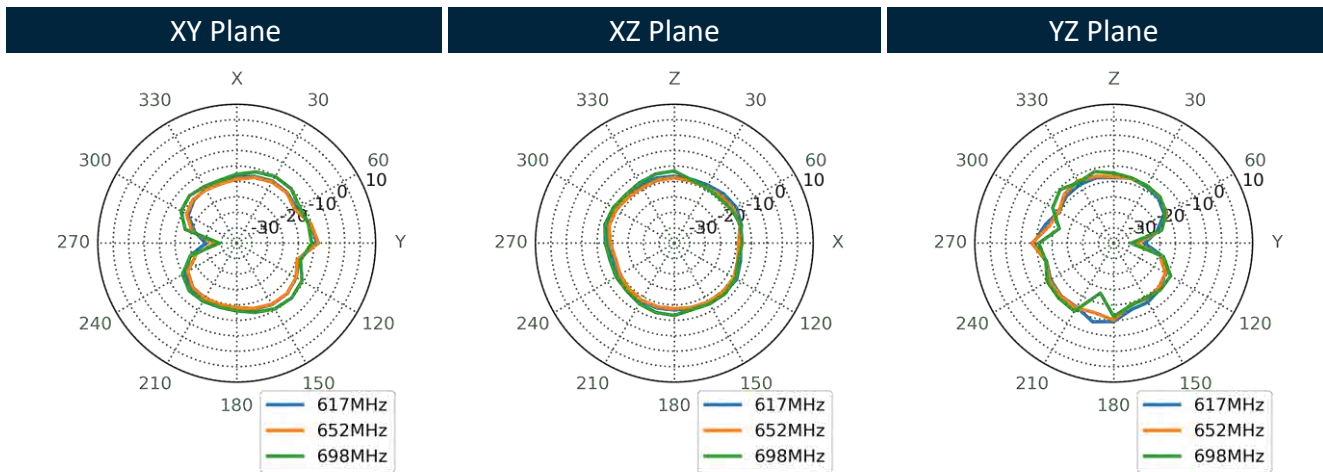

751MHz



XY Plane      XZ Plane      YZ Plane

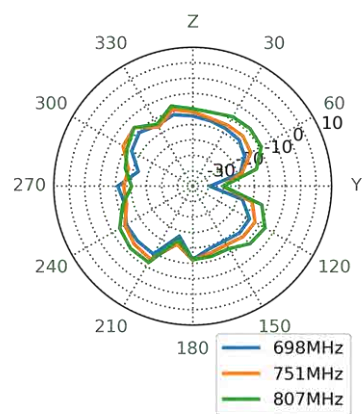
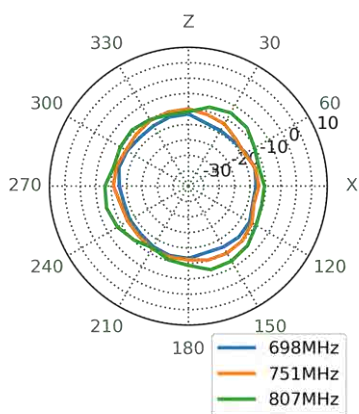
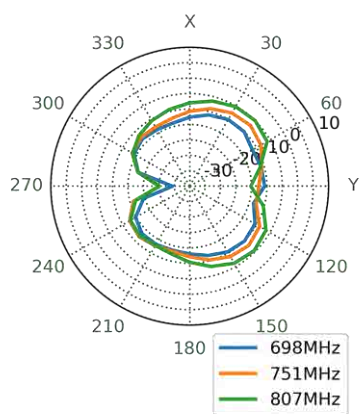

890MHz

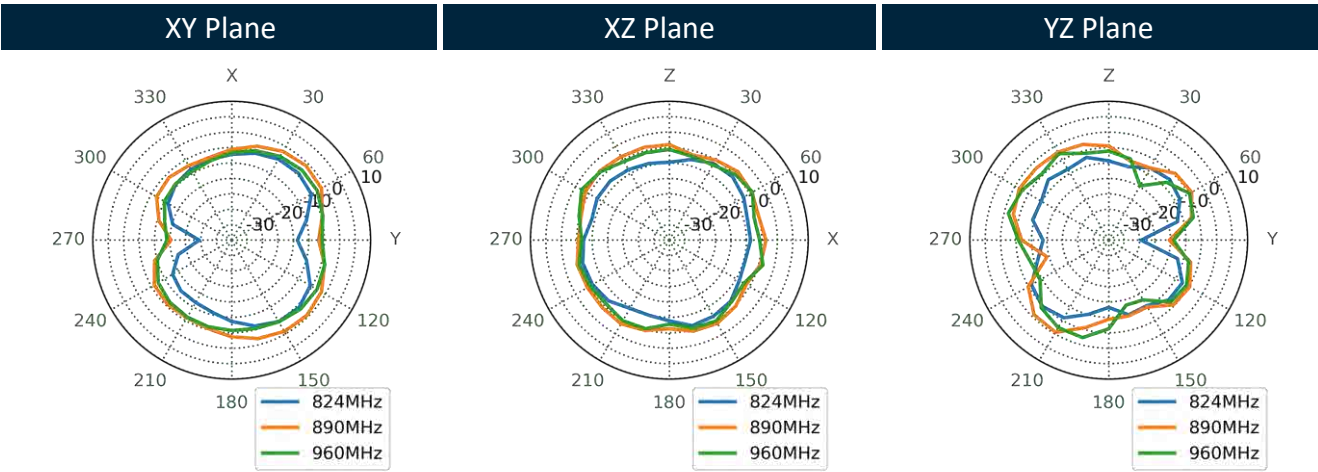



1470MHz

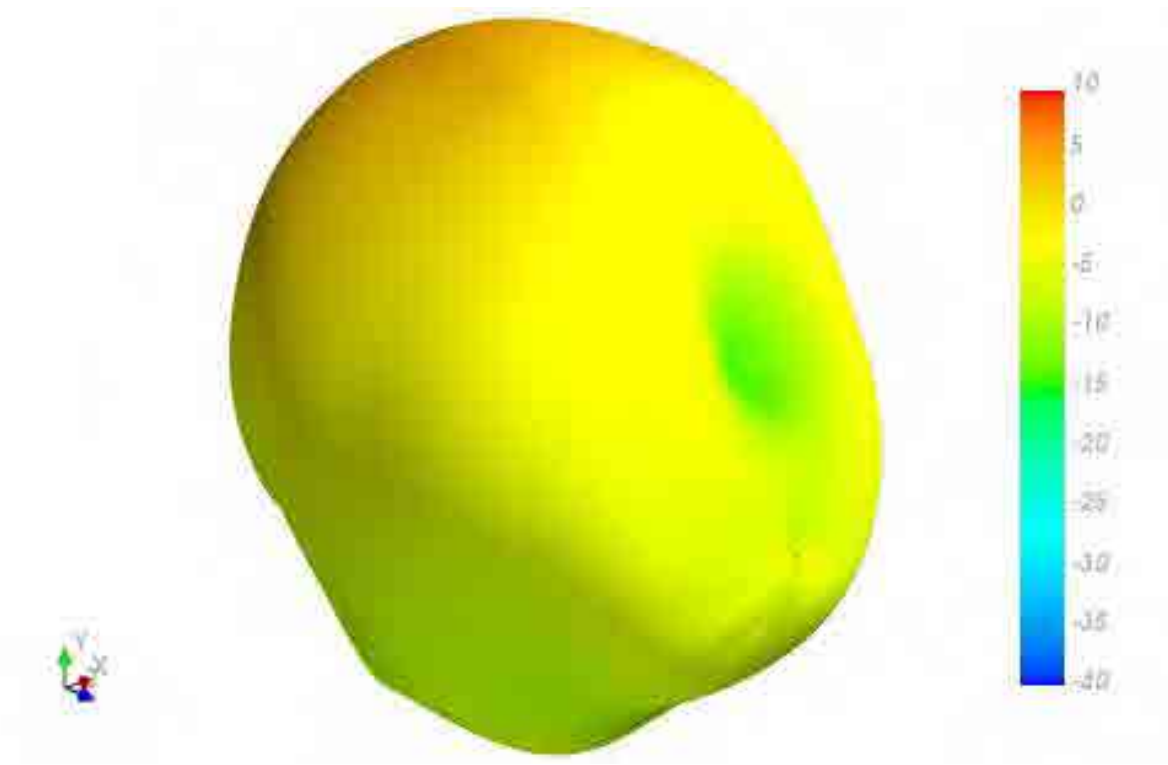

XY Plane

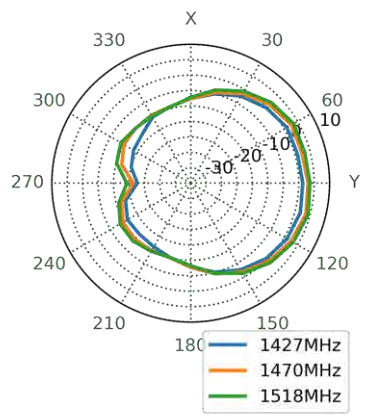

XZ Plane

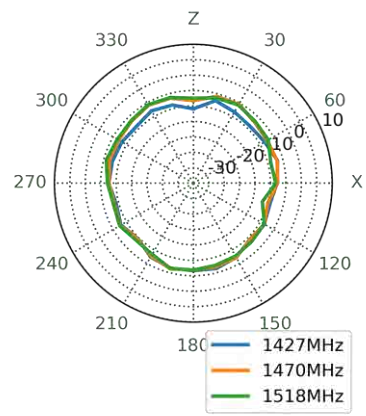

YZ Plane

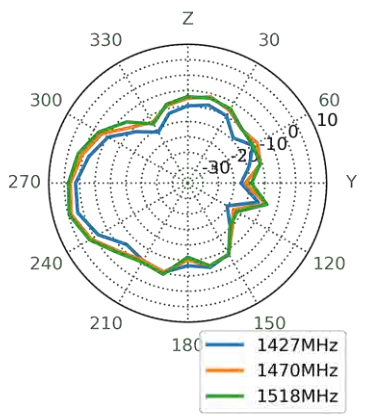

1805MHz

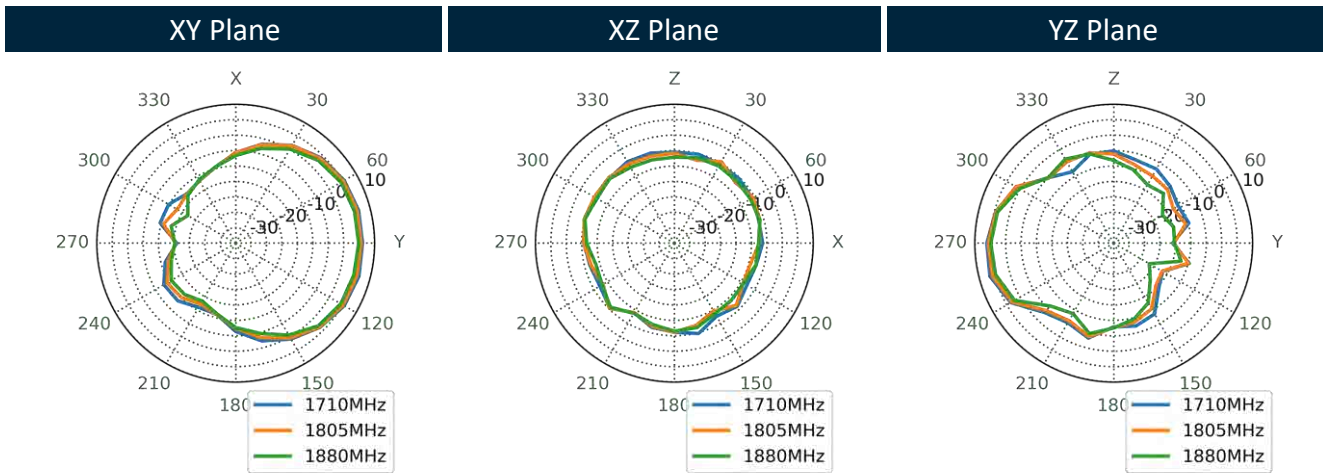
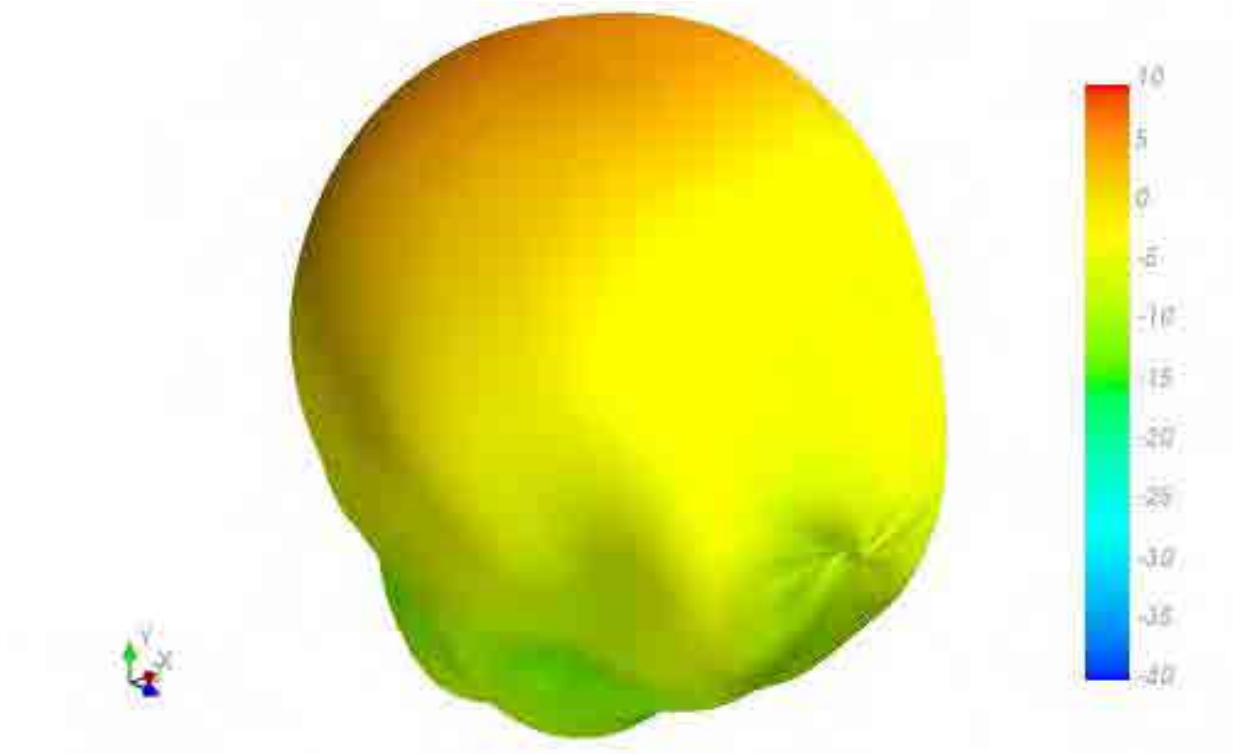

1920MHz

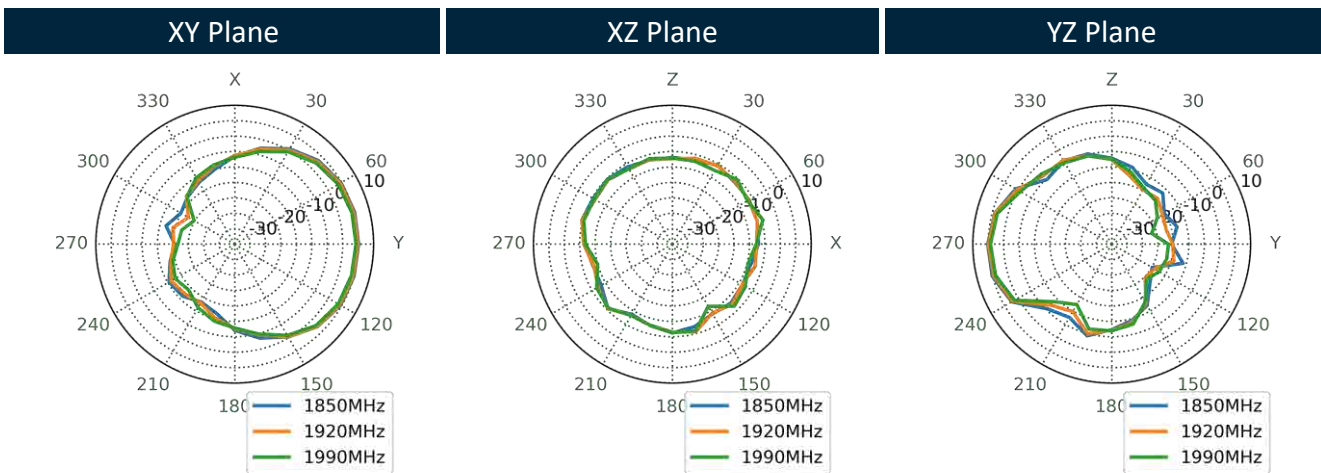
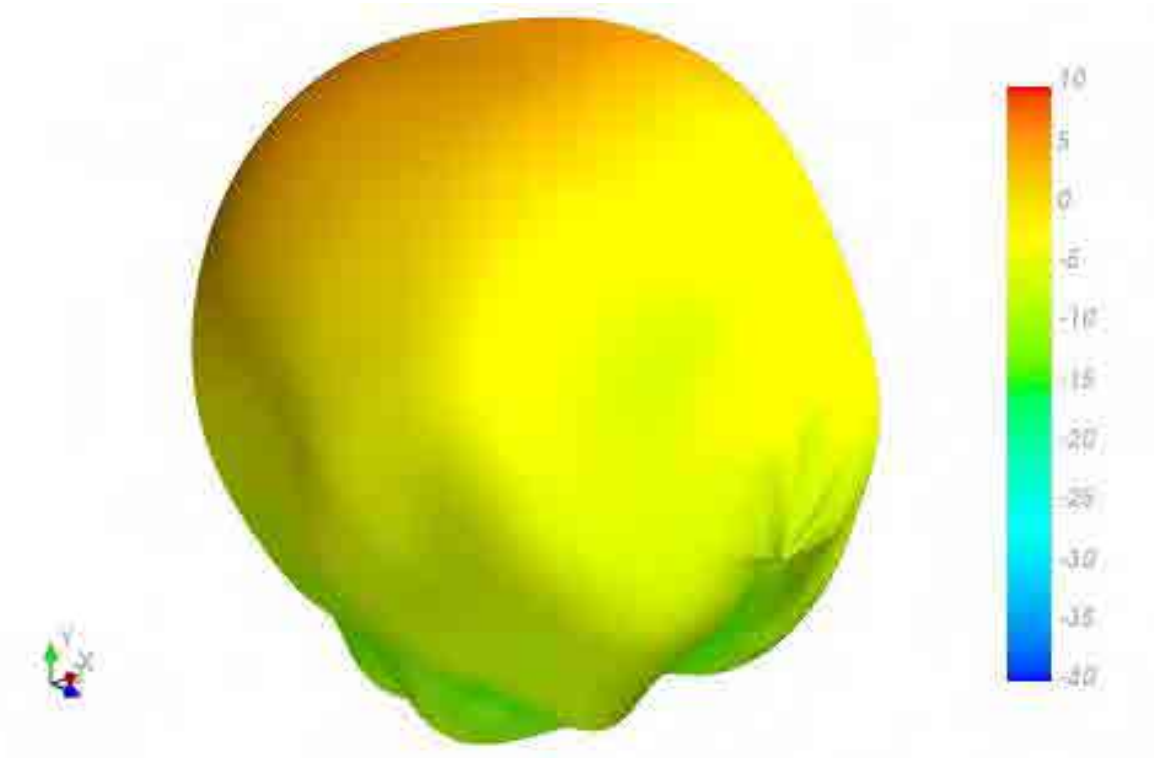

1990MHz

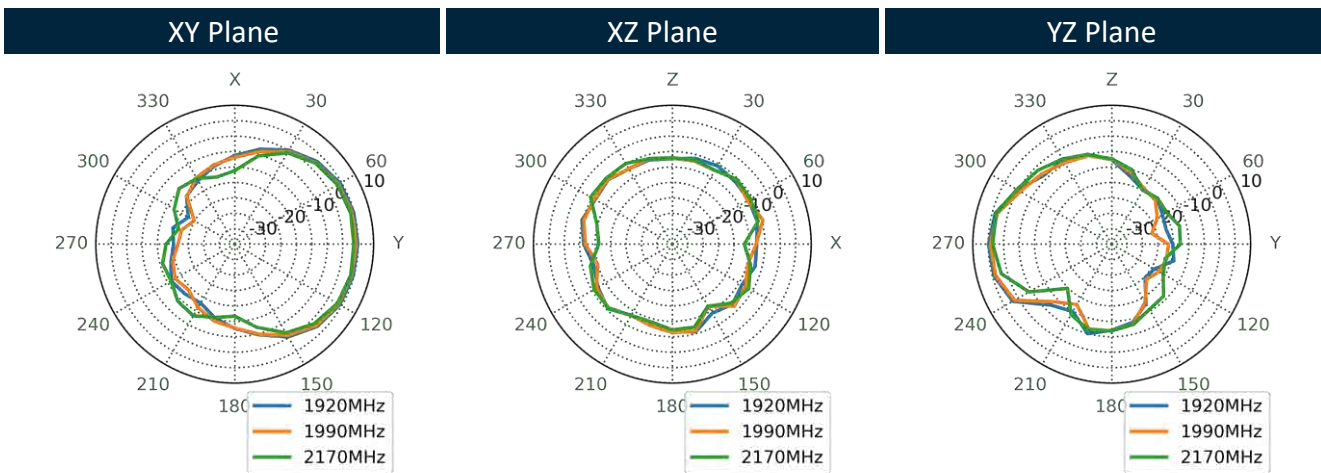

2595MHz

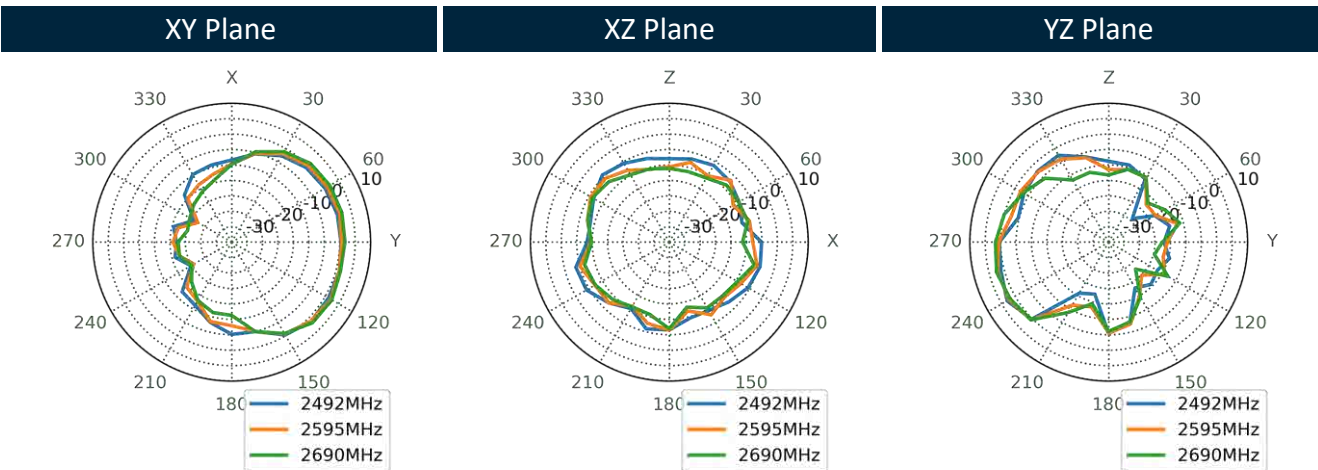
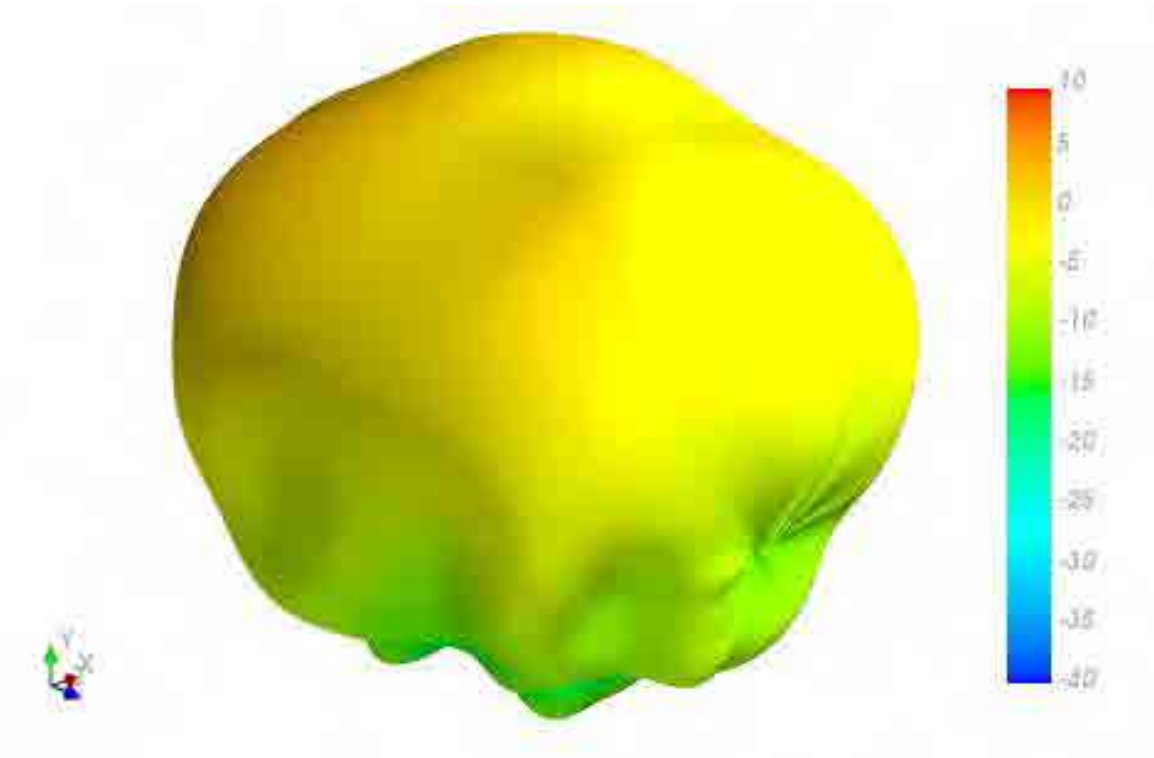

3550MHz

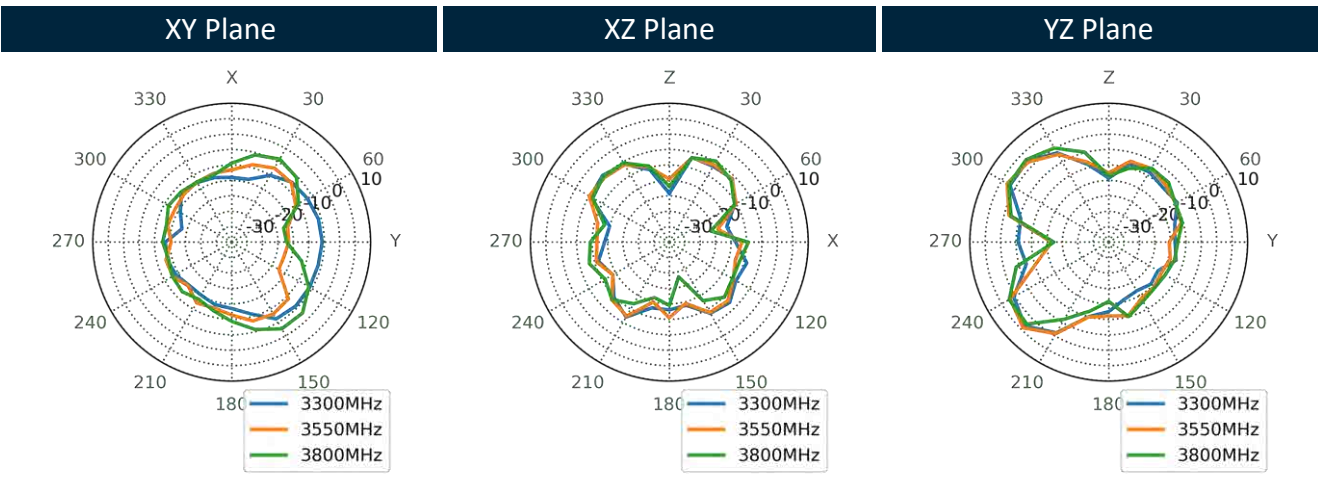
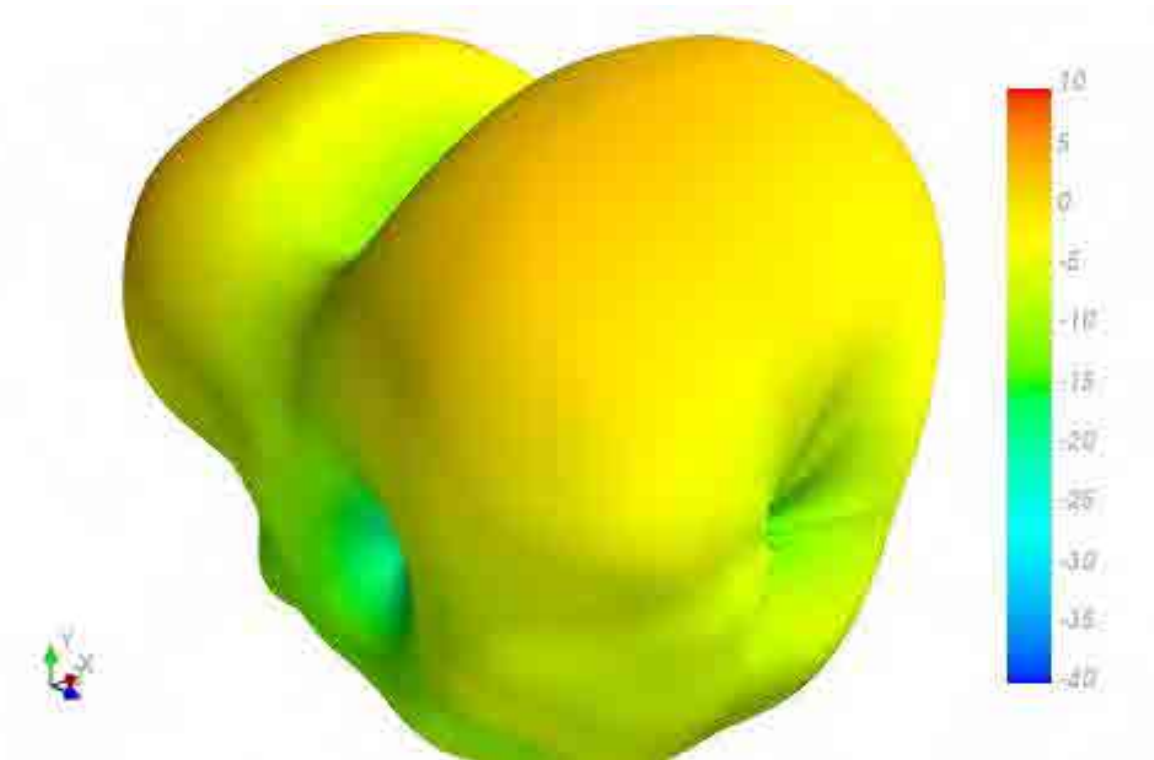

5530MHz

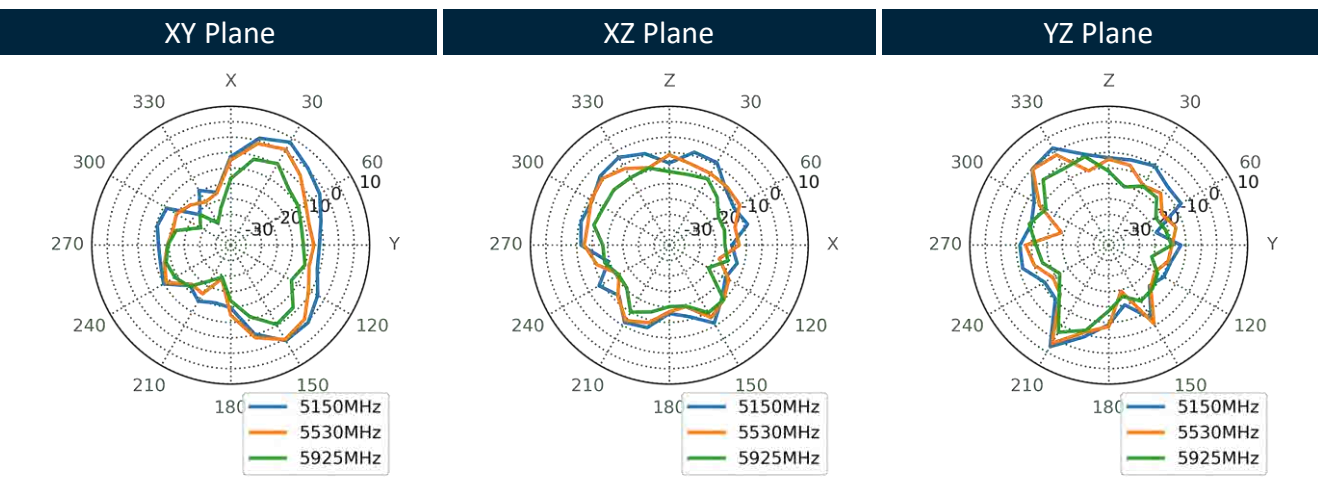
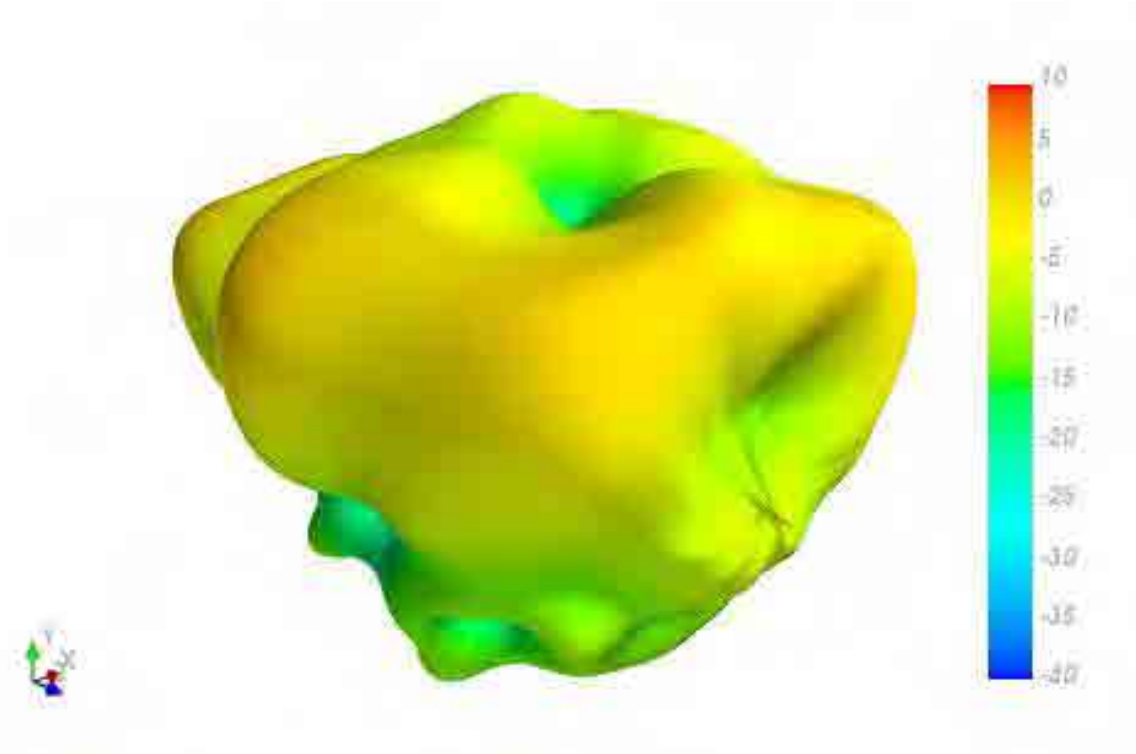



# 5. Mechanical Drawing (Units: mm)

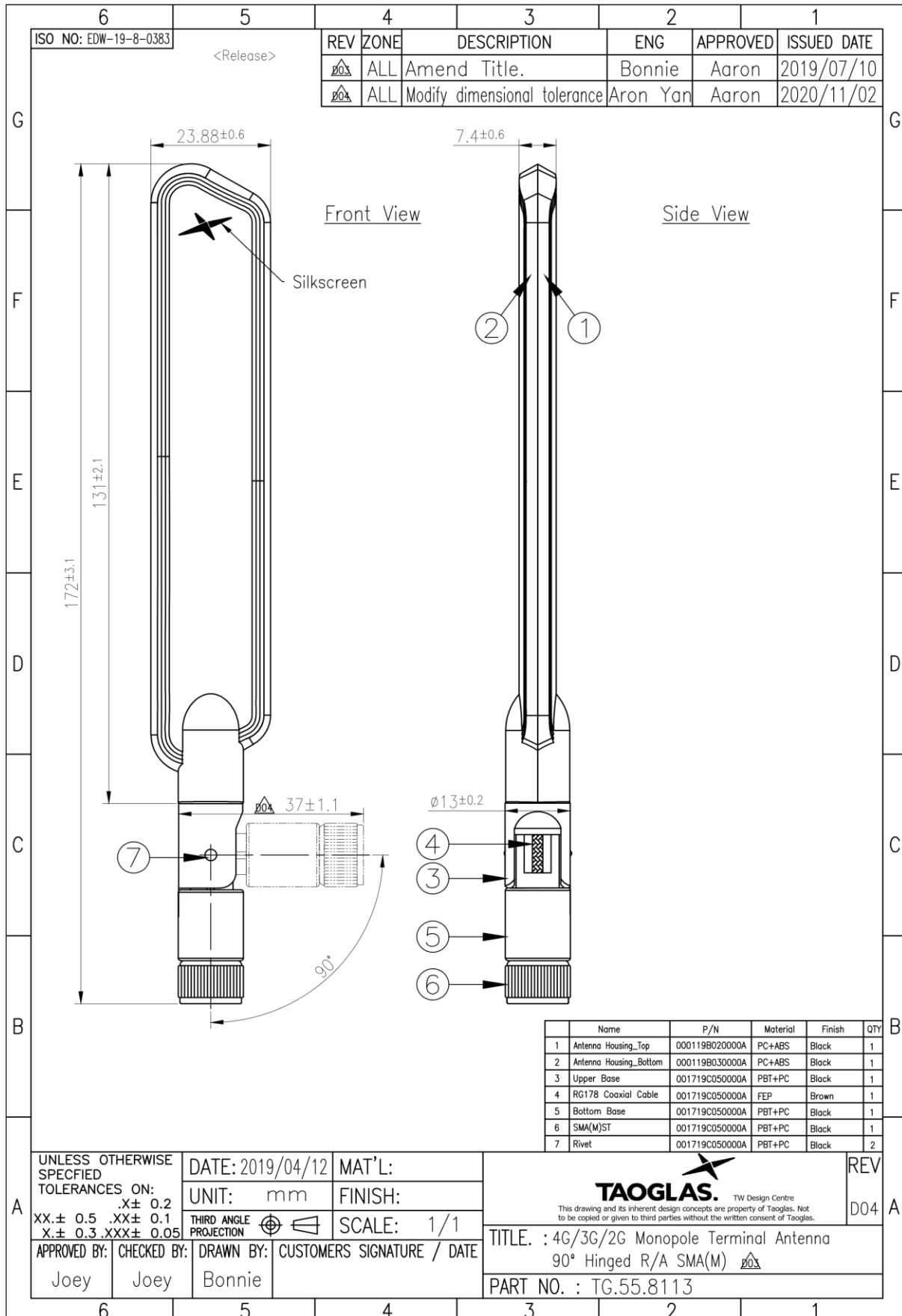

## 6. Packaging

1pc TG.55.8113 per Small PE Bag  
 Dimensions: 30\*210mm  
 Weight: 31g

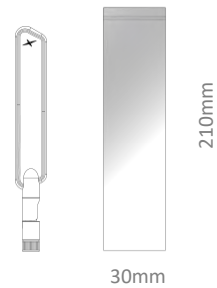

20pcs per Large PE Bag  
 Dimensions: 180\*265mm  
 Weight: 620g

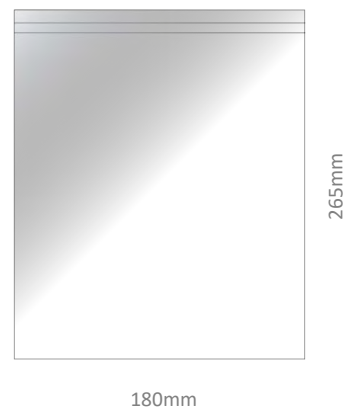

400pcs TG.55.8113 per Carton  
 Carton Dimensions: 320\*250\*230mm  
 Weight: 13Kg

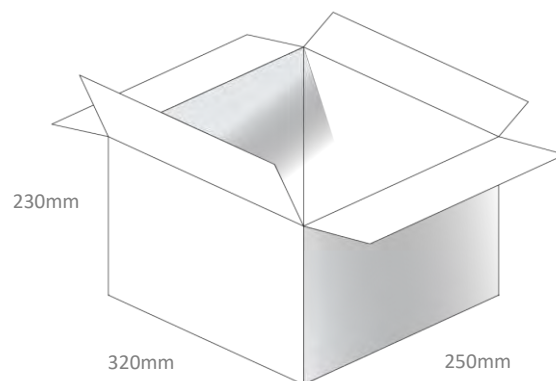

Pallet Dimensions:  
 1200\*1000\*1350mm  
 60 Cartons per Pallet  
 12 Cartons per layer, 5 Layers

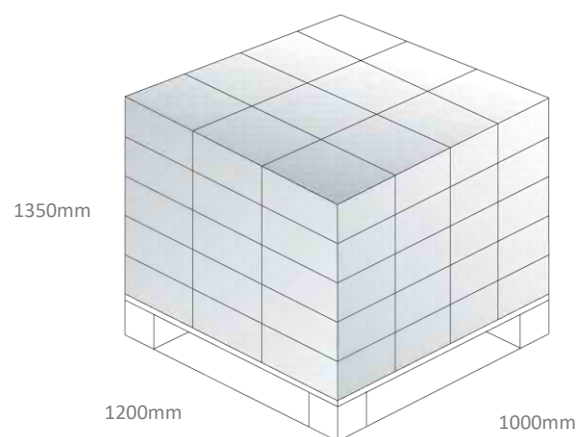

## 7. Application Note

### 3.1 Return Loss

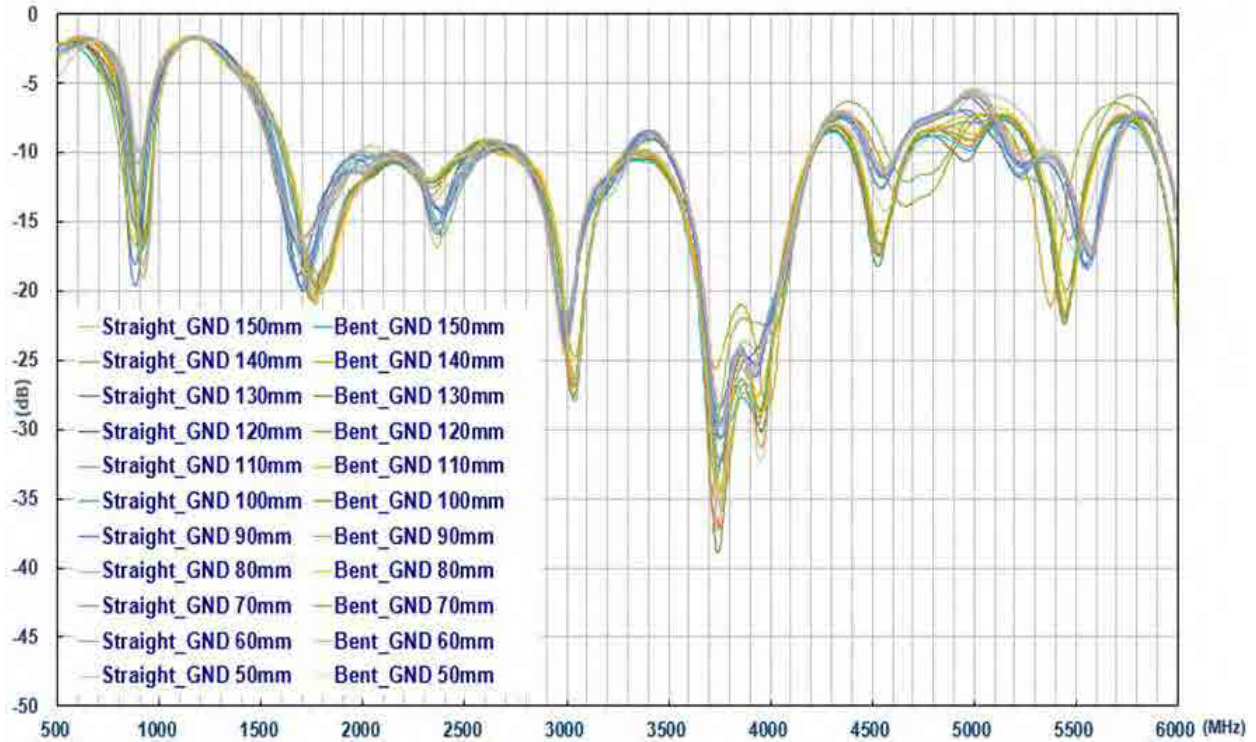

### 3.2 Efficiency

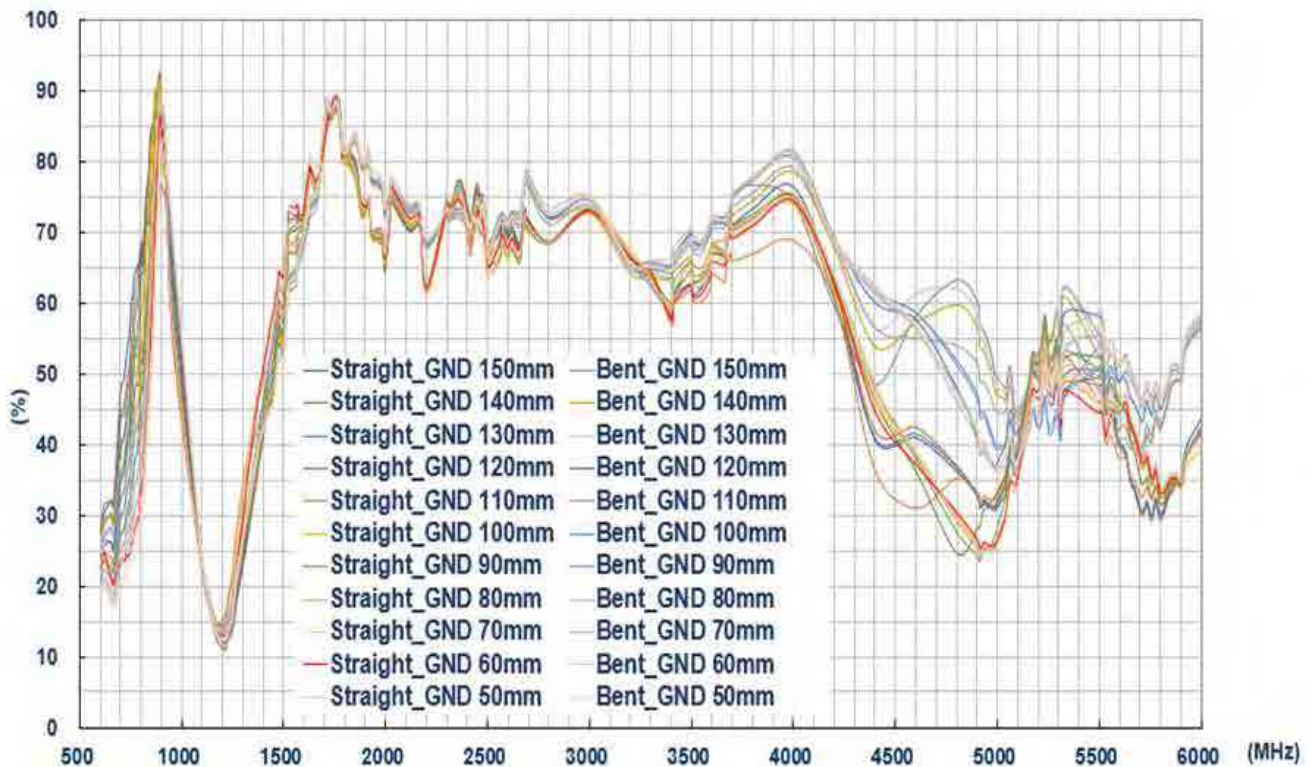

### 3.3 Average Gain



### 3.4 Peak Gain

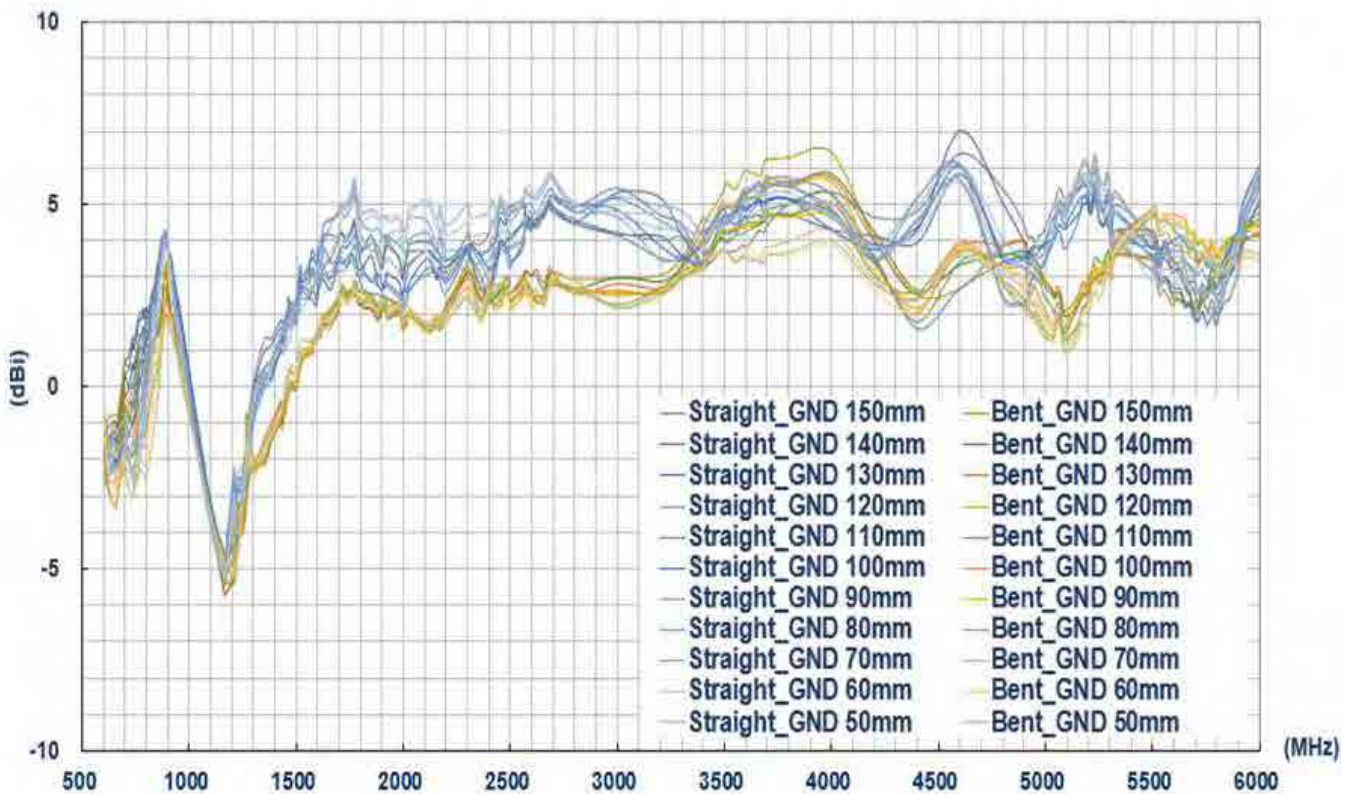



Changelog for the datasheet

**SPE-19-8-061 – TG.55.8113**

**Revision: E (Current Version)**

Date:	2022-07-05
Changes:	Updatd drawing
Changes Made by:	Jack Conroy

**Previous Revisions**

**Revision: D**

Date:	2020-11-10
Changes:	Updated drawing
Changes Made by:	Jack Conroy

**Revision: C**

Date:	2019-10-16
Changes:	Updated data to include new ground planes
Changes Made by:	Jack Conroy

**Revision: B**

Date:	2019-08-29
Changes:	Updated description
Changes Made by:	David Connolly

**Revision: A (Initial Launch)**

Date:	2019-05-22
Changes:	Initial Specification Release
Changes Made by:	Jack Conroy



**TAOGLAS®**

[www.taoglas.com](http://www.taoglas.com)



# Mouser Electronics

Authorized Distributor

Click to View Pricing, Inventory, Delivery & Lifecycle Information:

[Taoglas:](#)

[TG.55.8113](#)