

TABLE 1: GXA FMA PART NUMBER

PART NUMBER	DESCRIPTION
90000380-1	GXA FMA ASSEMBLY

TABLE 2: FMA EXTERNAL CONNECTORS IDENTIFICATION

REF. DES.	PART NUMBER	MATES WITH	FUNCTION	REMARKS
P1	PART NUMBER D38999/26FC4PN AMPHENOL CAGE CODE: 02660	PART NUMBER D38999/20FC4SN AMPHENOL CAGE CODE: 02660 SEE NOTE 17	POWER INPUT	4 PIN
P2	PART NUMBER D38999/26FB35PN AMPHENOL CAGE CODE: 02660	PART NUMBER D38999/20FB35SN AMPHENOL CAGE CODE: 02660 SEE NOTE 17	SIGNAL INTERFACE	13 PIN
P3	PART NUMBER D38999/26FB35PA AMPHENOL CAGE CODE: 02660	PART NUMBER D38999/20FB35SA AMPHENOL CAGE CODE: 02660 SEE NOTE 17	TX MUTE / IMU	13 PIN
J4	2.92mm FEMALE PART NUMBER SF1115-6045 SV MICROWAVE, INC CAGE CODE: 95077	2.92mm MALE SEE DETAIL F SHEET 8 MATING COAX DIMENSIONS	RF RX INTERFACE	NA
J5	90000804-001	SEE DETAIL E SHEET 8 MATING WAVEGUIDE DIMENSIONS	RF TX INTERFACE (WR34)	NA

TABLE 6: FMA ENVIRONMENTAL QUALIFICATION CHARACTERISTICS

ENVIRONMENTAL CONDITIONS	LIMITS	RTCA DO-160G SPECIFICATION
GROUND SURVIVAL LOW TEMPERATURE	-55°C	SECTION 4.5.1, CAT F2
OPERATING LOW TEMPERATURE	-55°C	SECTION 4.5.2, CAT F2
GROUND SURVIVAL HIGH TEMPERATURE	+90°C	SECTION 4.5.3, CAT F2
OPERATING HIGH TEMPERATURE	+70°C	SECTION 4.5.4, CAT F2
IN-FLIGHT LOSS OF COOLING	NOT APPLICABLE	NOT APPLICABLE
ALTITUDE	55,000 FT	SECTION 4.6.1, CAT F2
DECOMPRESSION	NOT APPLICABLE	NOT APPLICABLE
OVER PRESSURE	NOT APPLICABLE	NOT APPLICABLE
TEMPERATURE VARIATION	10°C / MIN.	SECTION 5, CAT A
HUMIDITY	85% RH AT 38°C 95% RH AT 65°C	SECTION 6, CAT B
OPERATIONAL SHOCK	3 SHOCKS OF 6G/11MS IN 6 DIRECTIONS 3 SHOCKS OF 6G/20MS IN 6 DIRECTIONS	SECTION 7, CAT B & E
CRASH SAFETY IMPULSE	1 SHOCK OF 20G/11MS IN 6 DIRECTIONS 1 SHOCK OF 20G/20MS IN 6 DIRECTIONS	SECTION 7, CAT B & E
CRASH SAFETY SUSTAINED	10G UP 8G DOWN 18G FORWARD 4G AFT 6G SIDE	SECTION 7, CAT B & E
VIBRATION	RANDOM CURVE C AND C1	SECTION 8, CAT S & R
EXPLOSIVE ATMOSPHERE	AIRCRAFT ZONE III (HEPTANE INSTEAD OF HEXANE)	SECTION 9, CAT E
WATER PROOFNESS	CONDENSING AND DRIP	SECTION 10, CAT Y & W
FLUIDS SUSCEPTIBILITY	DE-ICING FLUID (SPRAY TEST ONLY)	SECTION 11, CAT F
SAND AND DUST	DUST ONLY	SECTION 12, CAT D
FUNGUS RESISTANCE	BY ANALYSIS	SECTION 13, CAT F
SALT FOG	CAT S	SECTION 14, CAT S
ICING	CAT B	SECTION 24, CAT B

TABLE 3: P1 POWER CONNECTOR CONTACT ASSIGNMENT

PIN	SIGNAL
A	38VDC_POWER
B	38VDC_POWER_RETURN
C	FMA CHASSIS GROUND
D	SPARE

TABLE 5: P3 TX MUTE / IMU CONNECTOR CONTACT ASSIGNMENT

PIN	SIGNAL
1	IMU_TO_KANDU_422_DATA_HI
2	IMU_TO_KANDU_422_DATA_LO
3	KANDU_TO_IMU_422_DATA_HI
4	KANDU_TO_IMU_422_DATA_LO
5	IMU 24 V POWER
6	IMU 24 V POWER RETURN
7	TX TAIL_SECTOR_MUTE_SWITCH
8	TX TAIL_SECTOR_MUTE_SWITCH_RETURN
9	SPARE
10	SPARE
11	SPARE
12	SPARE
13	SPARE

TABLE 4: P2 SIGNAL CONNECTOR CONTACT ASSIGNMENT

PIN	SIGNAL
1	MAINTENANCE_ETHERNET_TX+
2	MAINTENANCE_ETHERNET_TX-
3	MAINTENANCE_ETHERNET_RX+
4	MAINTENANCE_ETHERNET_RX-
5	CMD_STATUS_422_RX_HI
6	CMD_STATUS_422_RX_LO
7	CMD_STATUS_422_TX_HI
8	CMD_STATUS_422_TX_LO
9	CMD_STATUS_422_REFERENCE GROUND
10	SPARE
11	SPARE
12	SPARE
13	SPARE

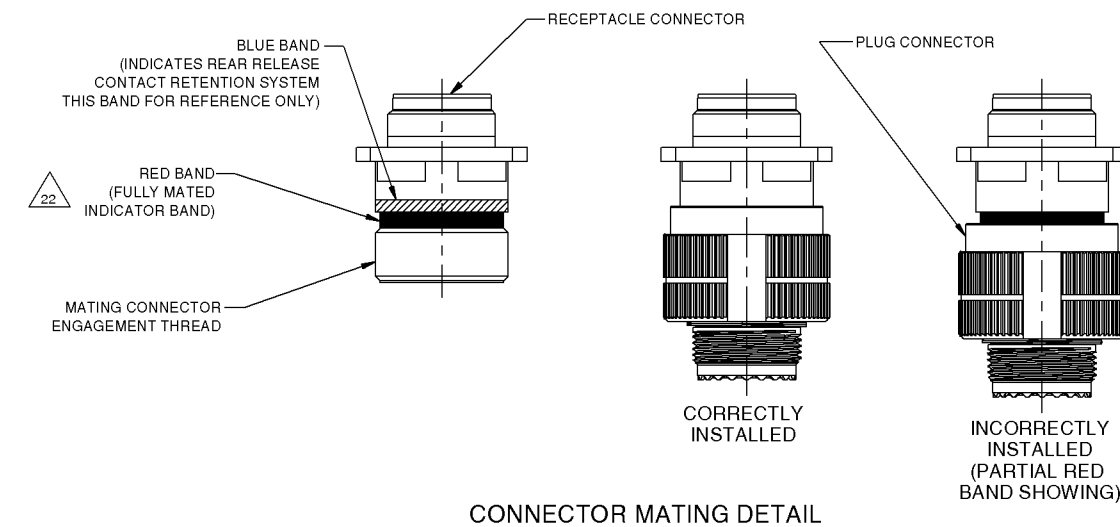

Figure 4-31. (Sheet 2 of 14) FMA Outline and Installation Drawing (90000380ICD, REV L)

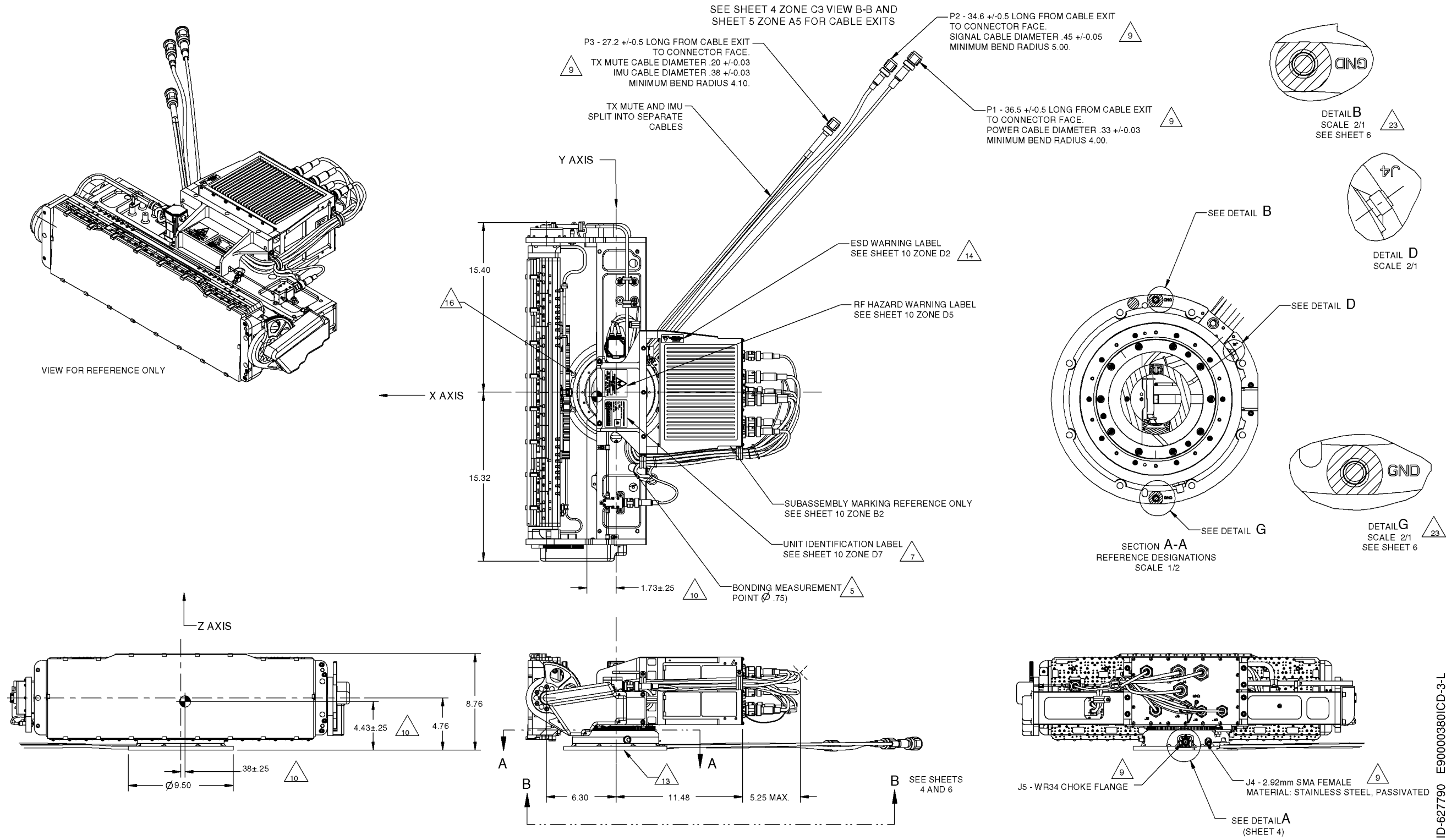
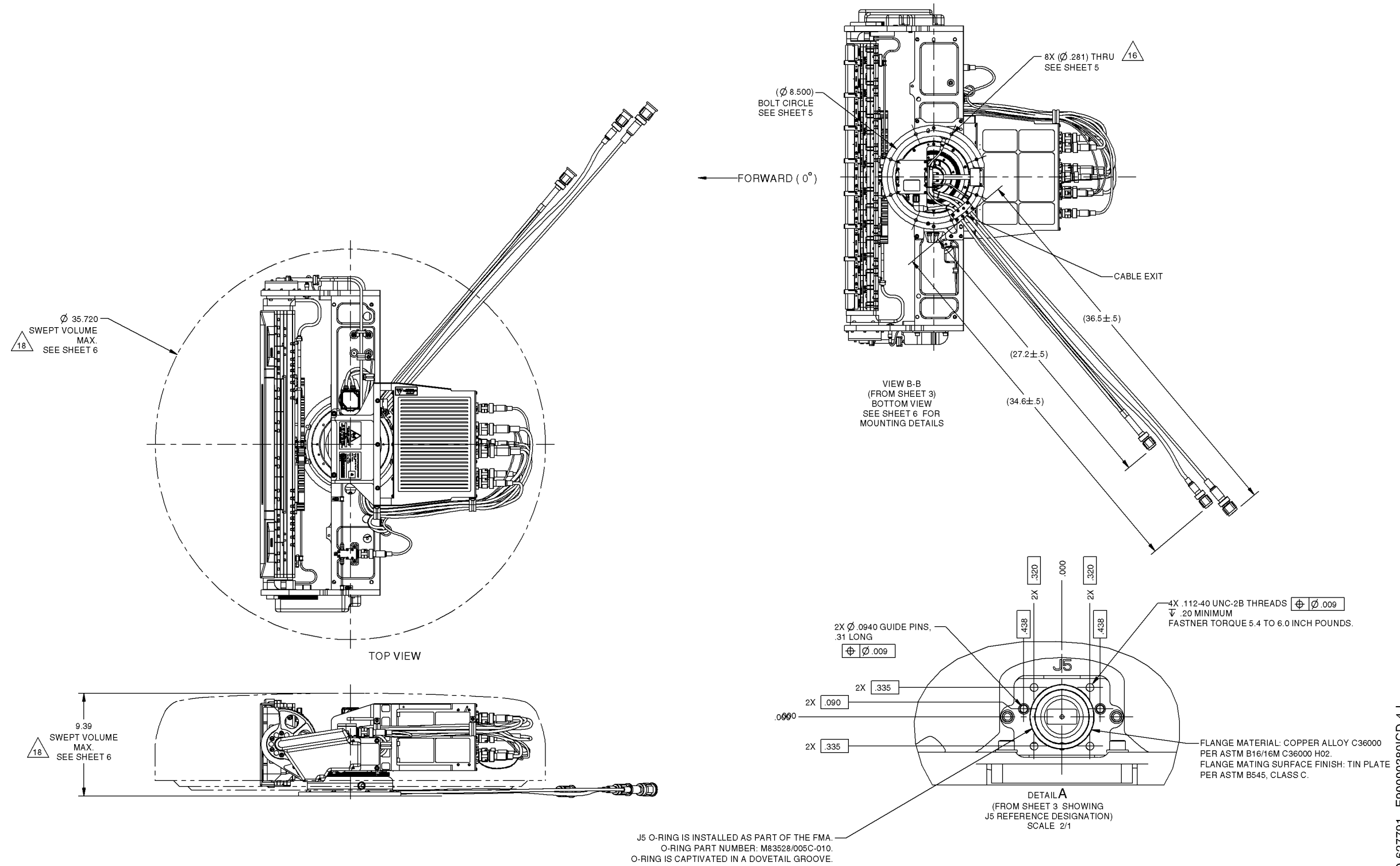

Figure 4-31. (Sheet 3 of 14) FMA Outline and Installation Drawing (90000380ICD, REV L)



ID-627791 E90000380ICD-4-L

Figure 4-31. (Sheet 4 of 14) FMA Outline and Installation Drawing (90000380ICD, REV L)

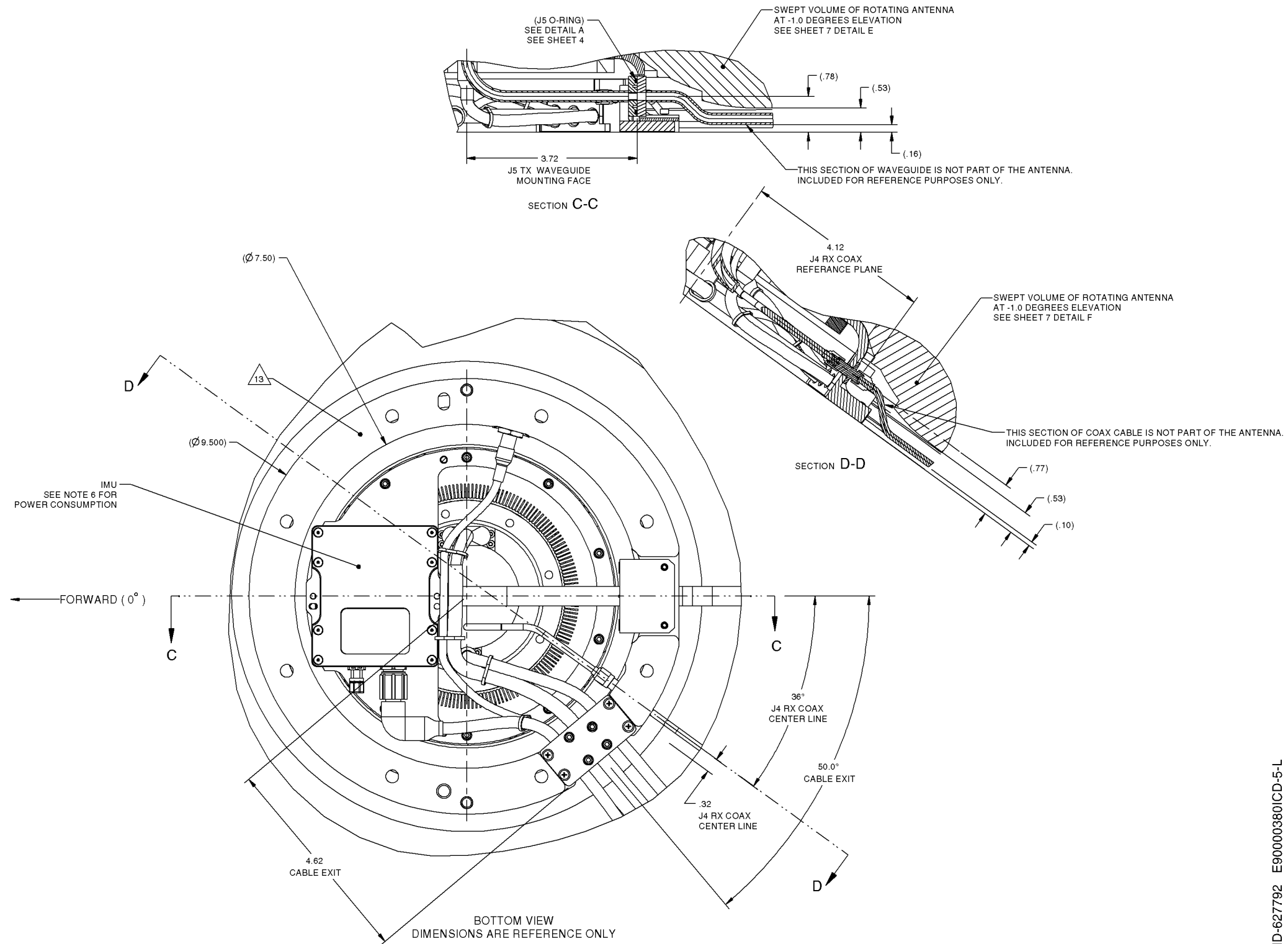
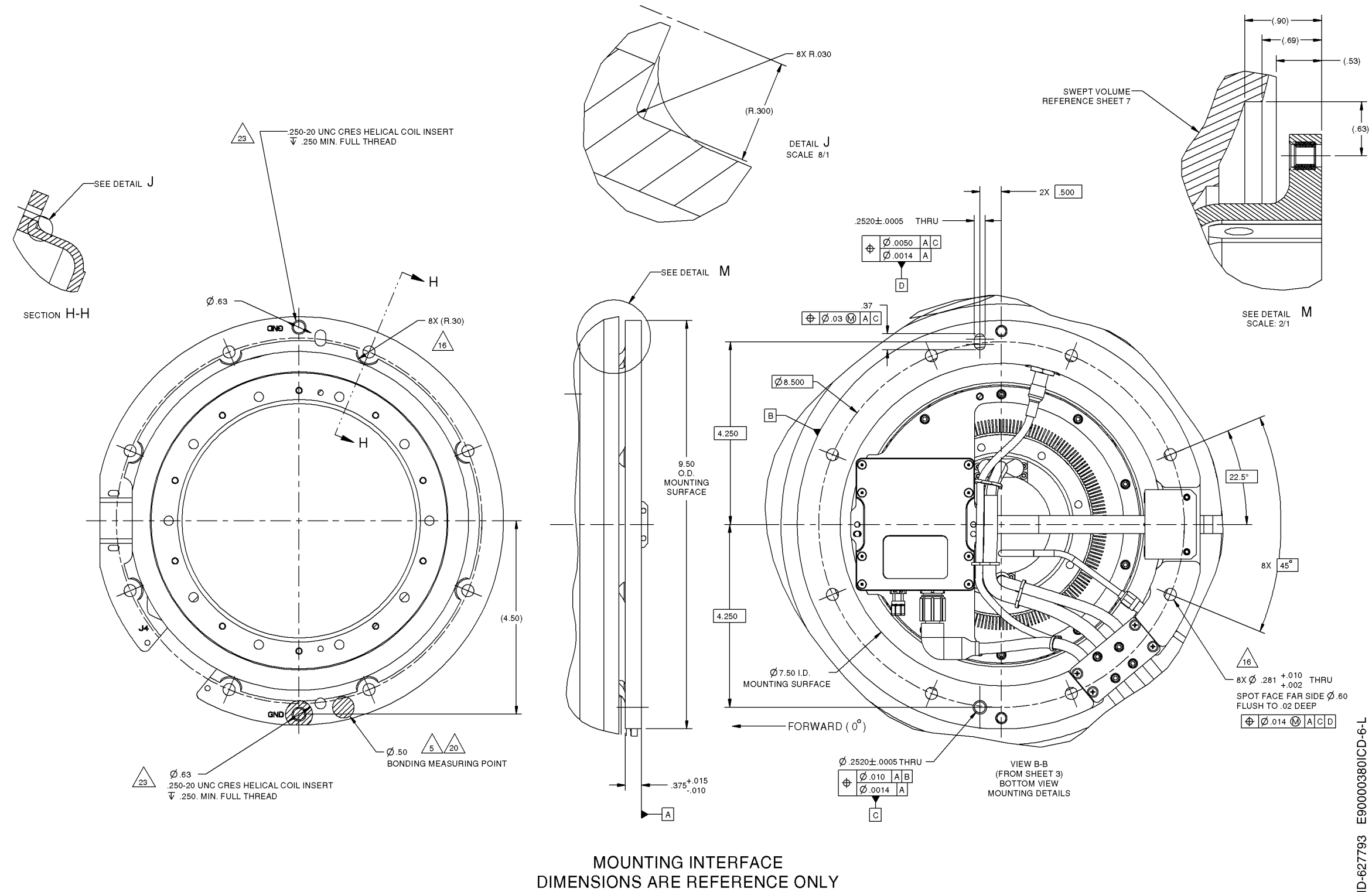

Figure 4-31. (Sheet 5 of 14) FMA Outline and Installation Drawing (90000380ICD, REV L)



ID-627793 E90000380ICD-6-L

Figure 4-31. (Sheet 6 of 14) FMA Outline and Installation Drawing (90000380ICD, REV L)

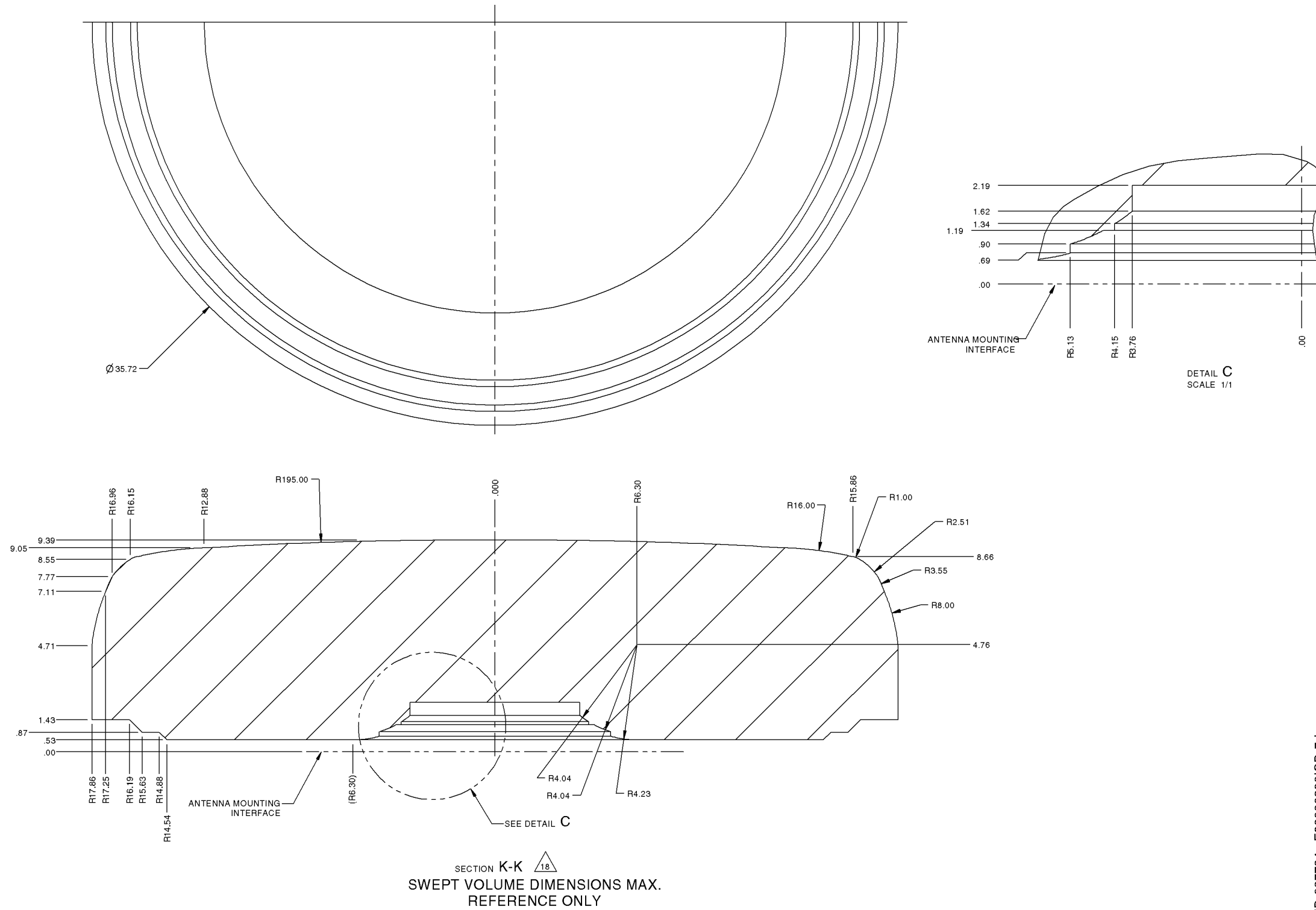

Figure 4-31. (Sheet 7 of 14) FMA Outline and Installation Drawing (90000380ICD, REV L)

INFORMATION CONTAINED ON THIS SHEET IS NOT PART OF THE ANTENNA. INCLUDED FOR REFERENCE PURPOSES ONLY.

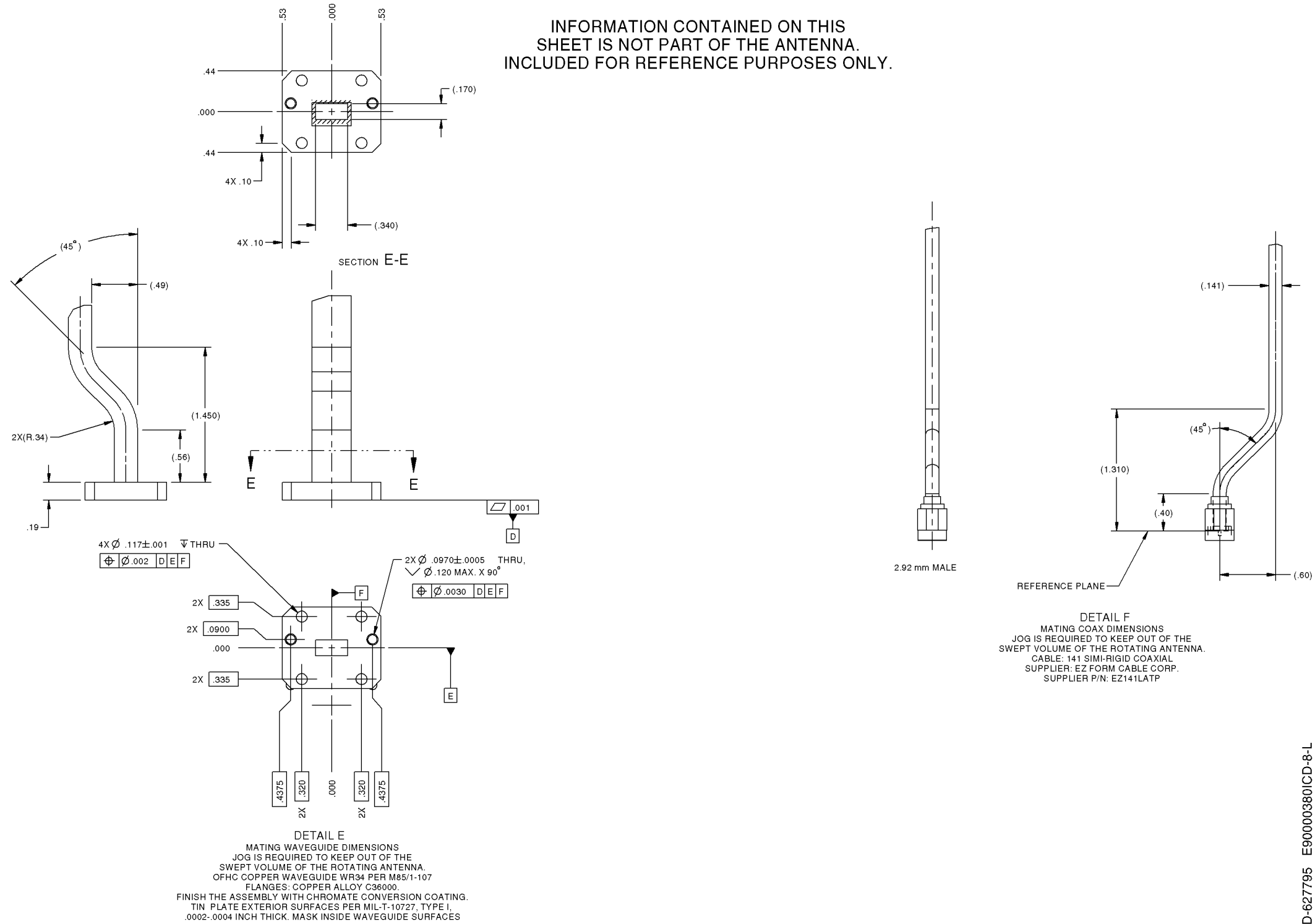

Figure 4-31. (Sheet 8 of 14) FMA Outline and Installation Drawing (90000380ICD, REV L)

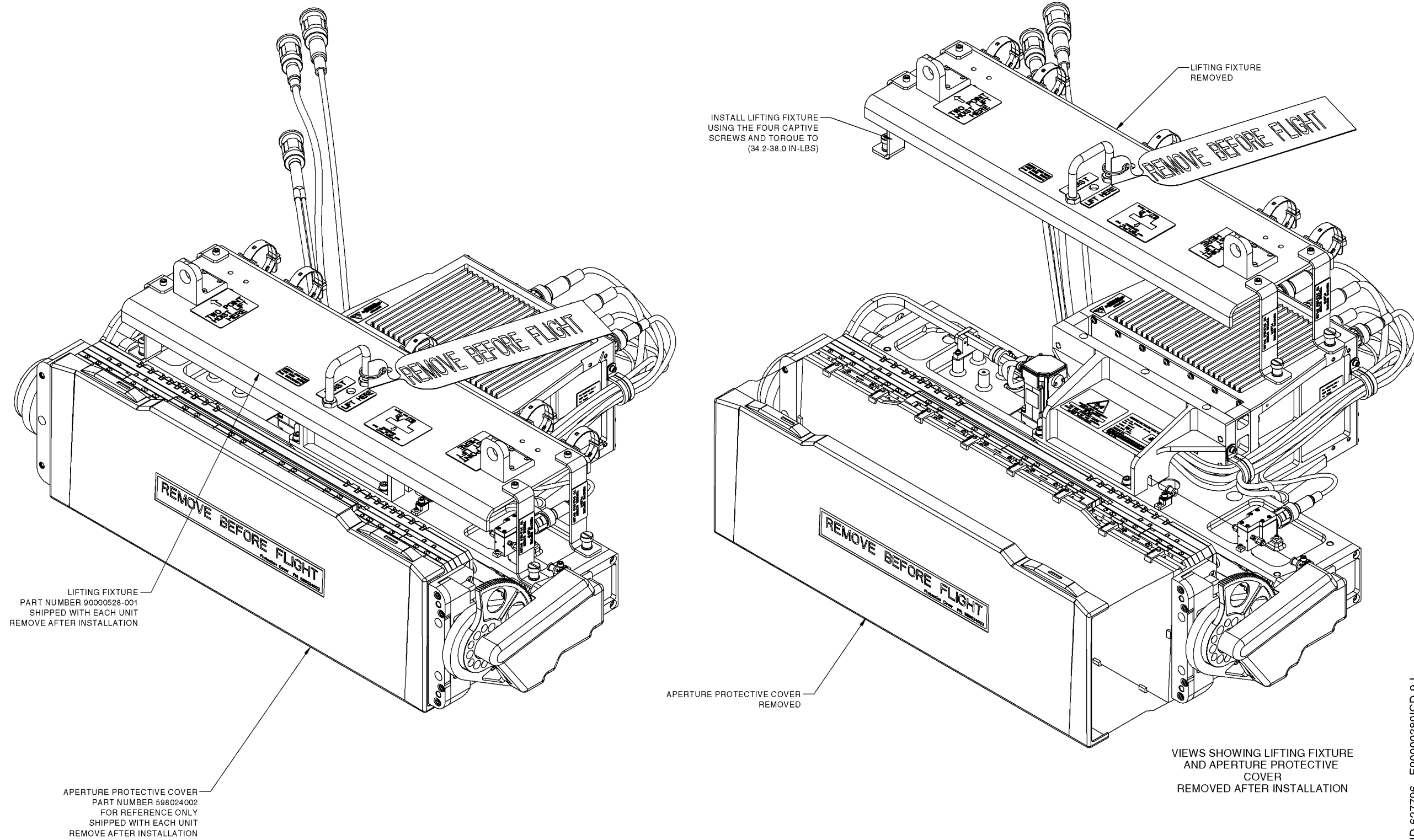

Figure 4-31. (Sheet 9 of 14) FMA Outline and Installation Drawing (90000380ICD, REV L)

Honeywell

DESCRIPTION GXA FUSELAGE MOUNT ANTENNA

H/W P/N 90000380-1 REV XXX
S/N XXXXX

DATE MM,YYYY

WEIGHT 83.00 lb
37.64 kg

CAGE CODE 5VWN5

QR
CODE
HERE

HARDWARE MOD

1	2	3	4	5	6	7	8	9	10	11	12	13	14	15
16	17	18	19	20	21	22	23	24	25	26	27	28	29	30

MADE IN USA

UNIT IDENTIFICATION LABEL
SCALE 4/1

CAUTION HIGH FREQUENCY
RADIATION HAZARD

30 GHz

DO NOT APPROACH WITHIN
66.6ft (20.3M) OF THE ANTENNA
DURING TRANSMISSION

RF HAZARD WARNING LABEL
SCALE 2/1

TRIANGLE IS YELLOW
WITH BLACK BORDER
AND SYMBOL

CAUTION

CONTAINS PARTS AND
ASSEMBLIES SUSCEPTIBLE TO
DAMAGE BY ELECTROSTATIC
DISCHARGE (ESD)

ESD WARNING LABEL
SCALE 4/1

LABEL BACKGROUND IS YELLOW
WITH BLACK TEXT, SYMBOL
AND OUTLINE

P/N 90000452-1 REV X

CAGE CODE 5VWN5

S/N XXXXX

SUBASSEMBLY MARKING REFERENCE ONLY
SCALE 4/1

ID-627797 E90000380ICD-10-L

Figure 4-31. (Sheet 10 of 14) FMA Outline and Installation Drawing (90000380ICD, REV L)

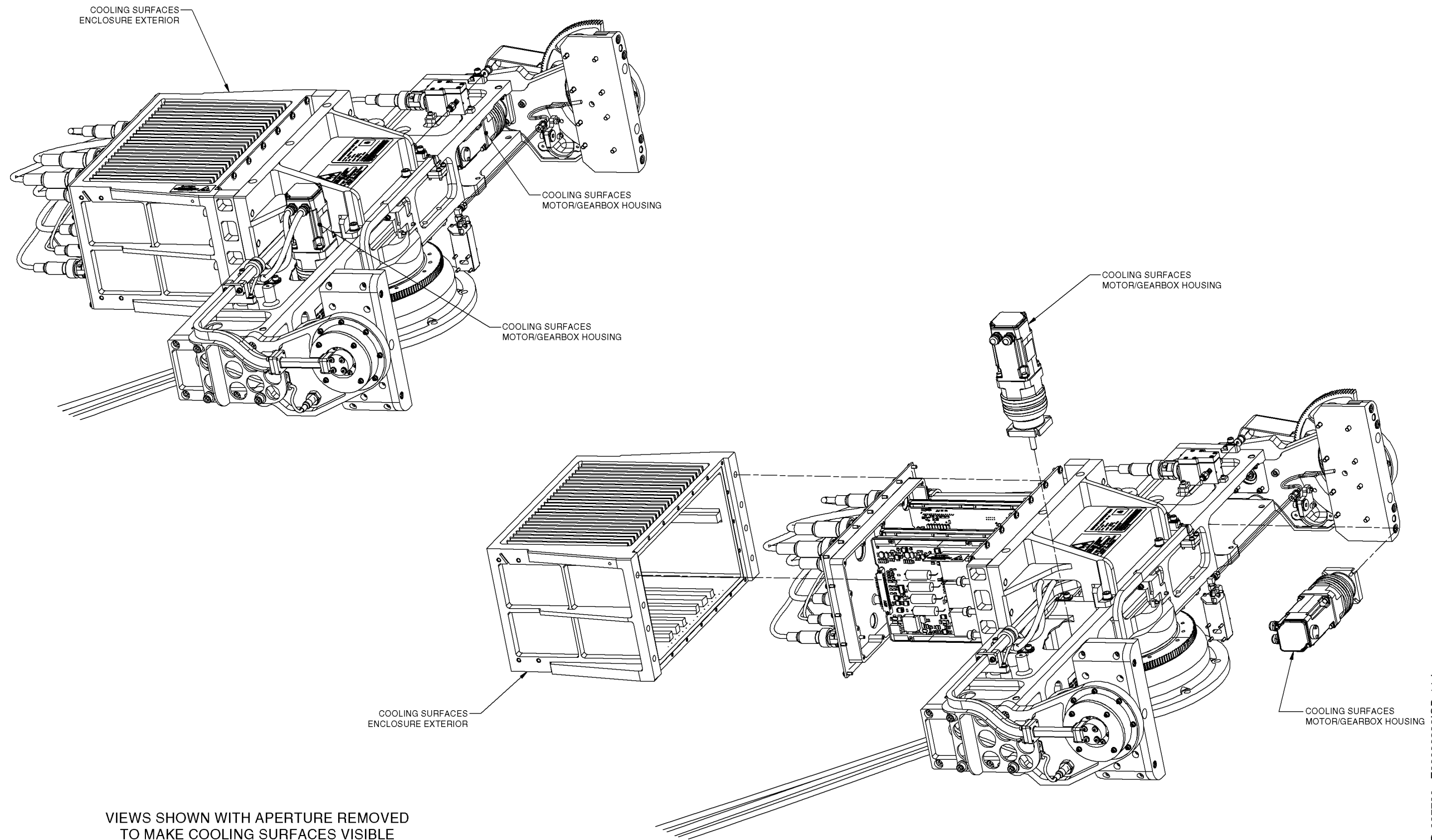

VIEWS SHOWN WITH APERTURE REMOVED
TO MAKE COOLING SURFACES VISIBLE

Figure 4-31. (Sheet 11 of 14) FMA Outline and Installation Drawing (90000380ICD, REV L)

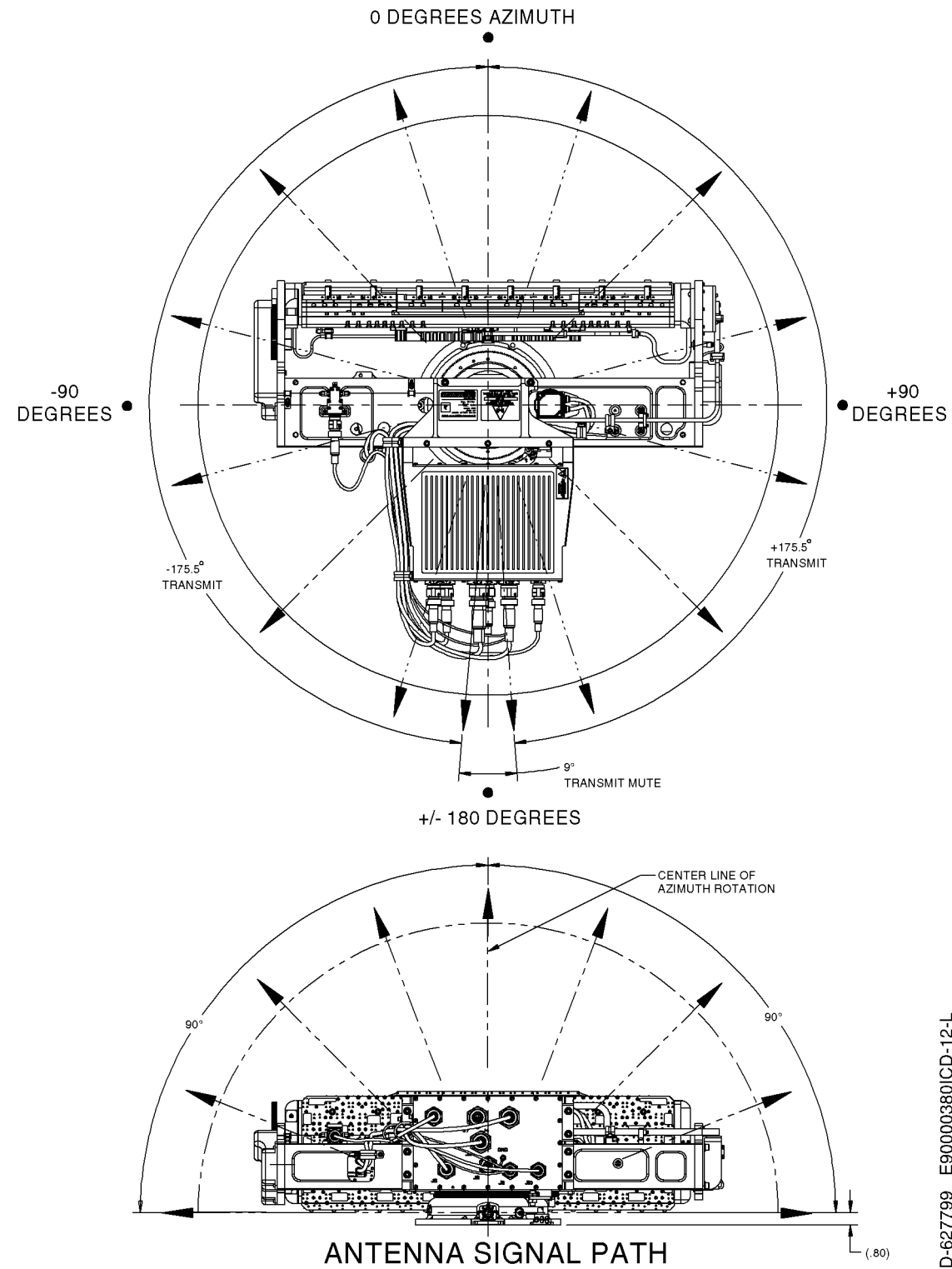

ID-627799 E90000380ICD-12-L

Figure 4-31. (Sheet 12 of 14) FMA Outline and Installation Drawing (90000380ICD, REV L)

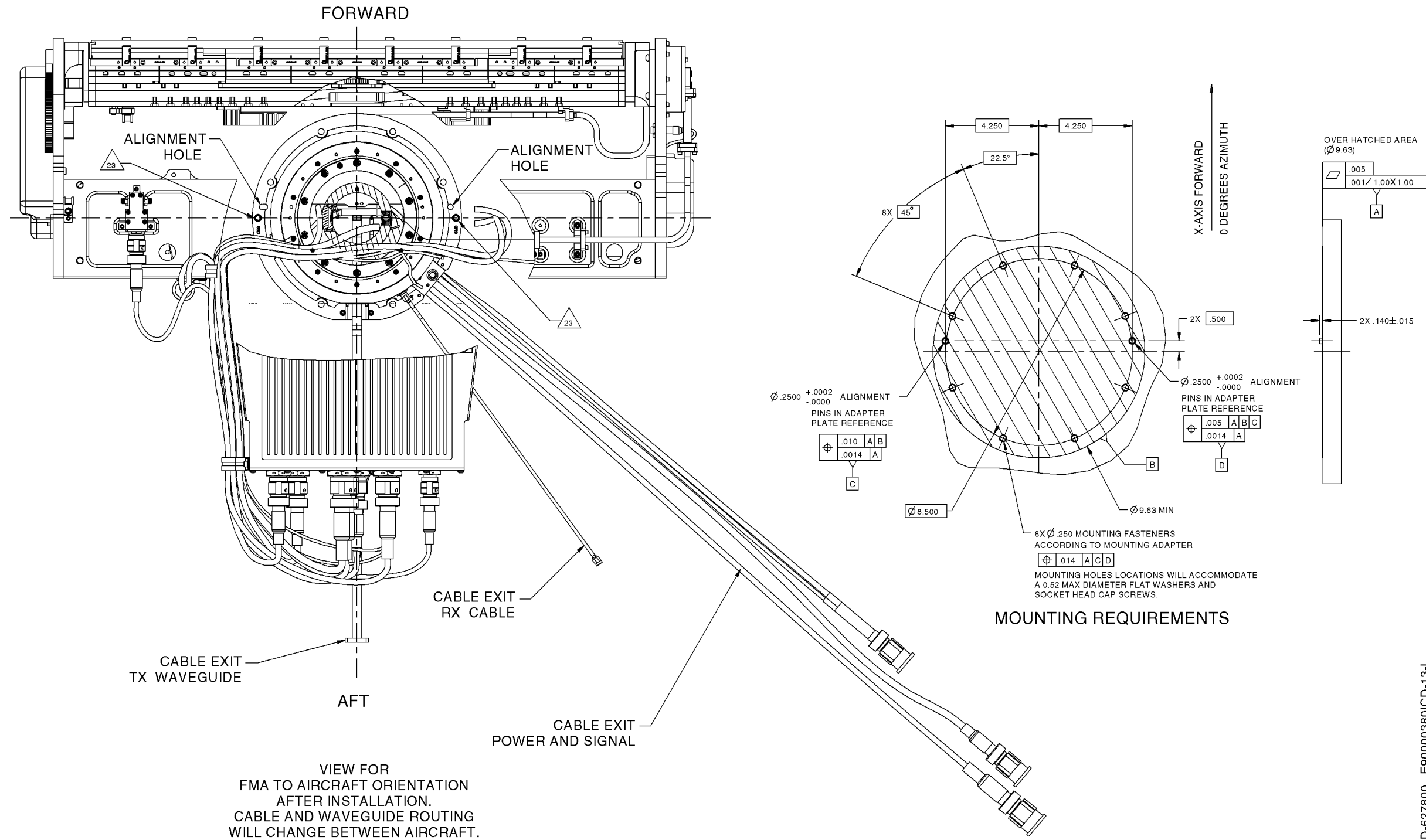

Figure 4-31. (Sheet 13 of 14) FMA Outline and Installation Drawing (9000380ICD, REV L)

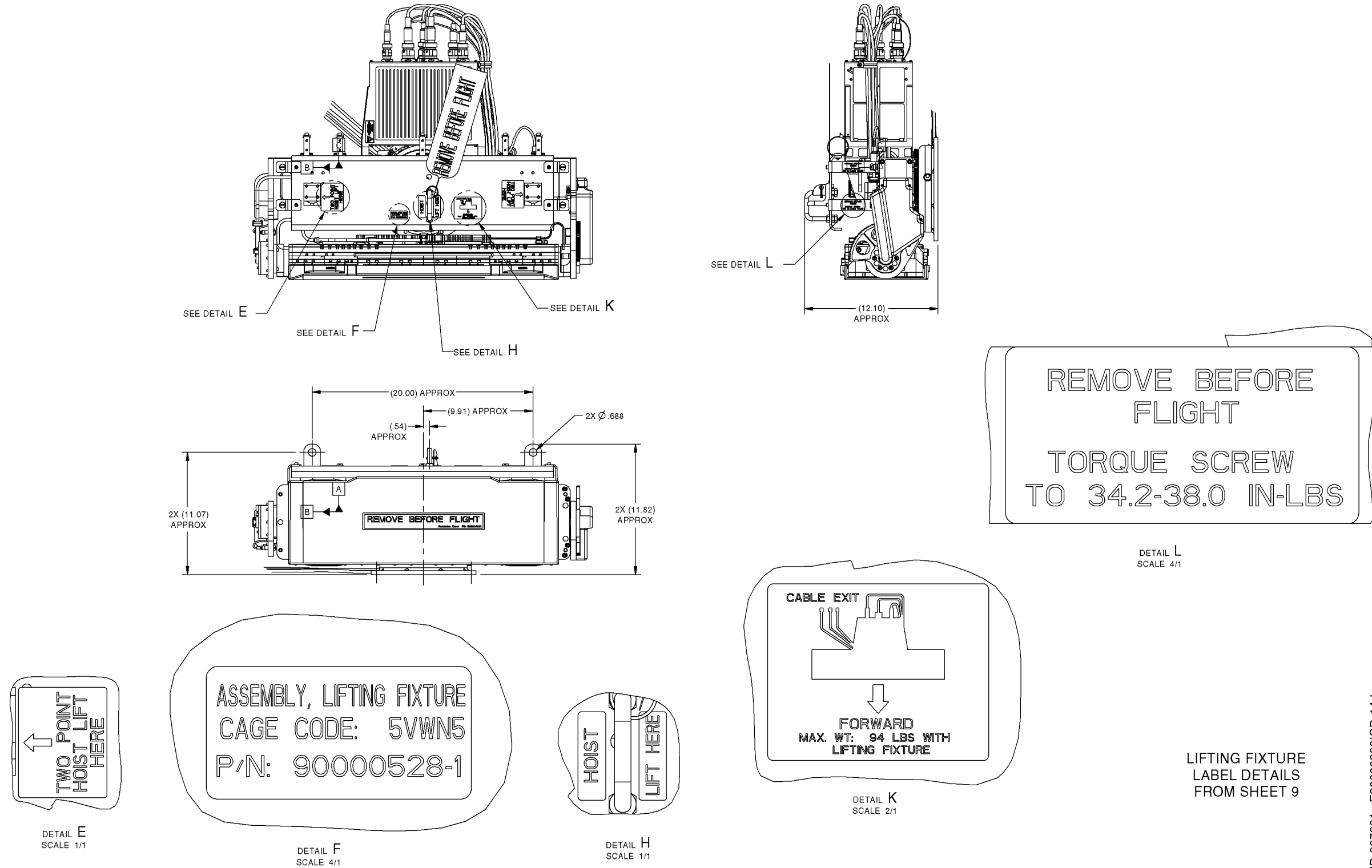
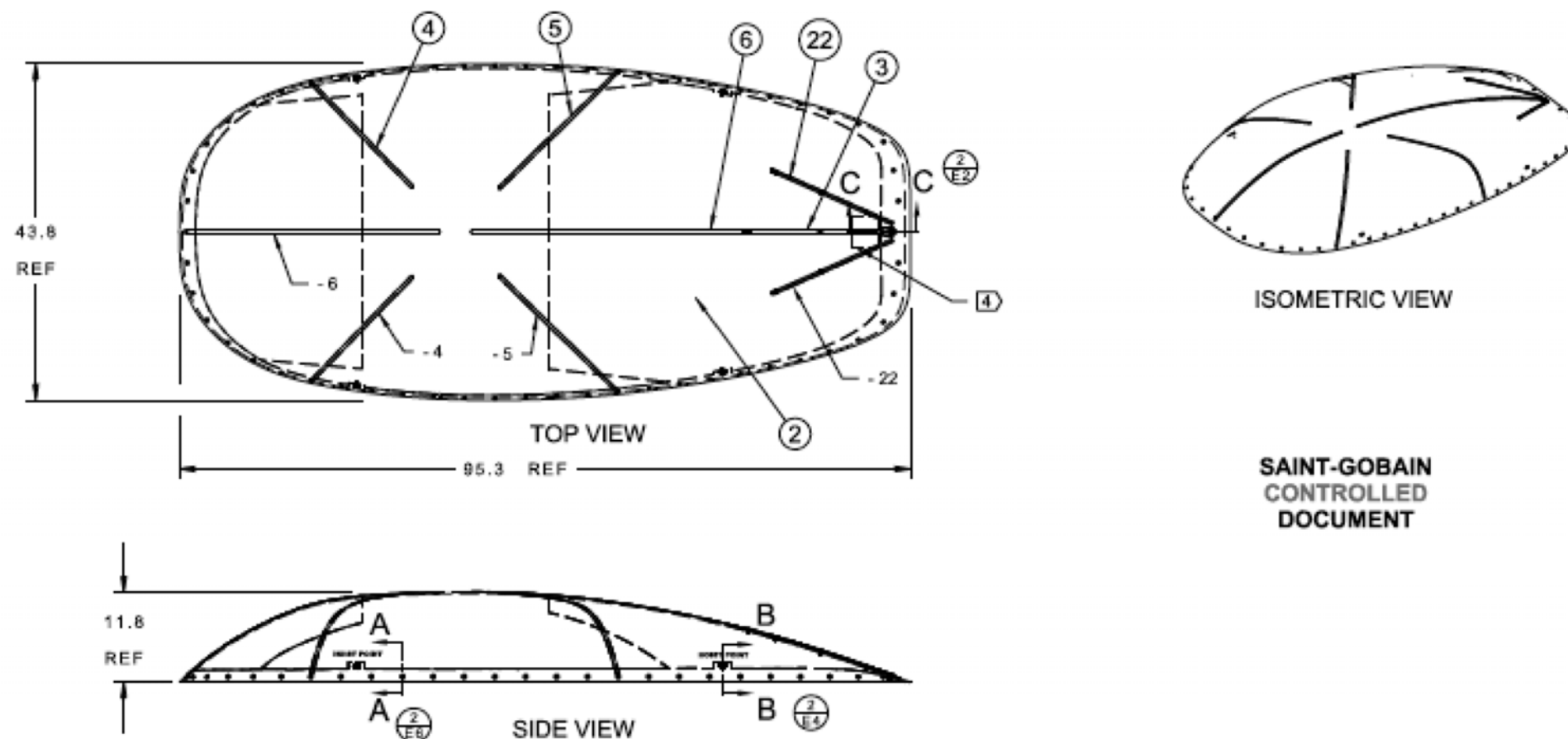

Figure 4-31. (Sheet 14 of 14) FMA Outline and Installation Drawing (90000380ICD, REV L)



ISOMETRIC VIEW

SAINT-GOBAIN
CONTROLLED
DOCUMENT

5249-200 - DORSAL RADOME ASSEMBLY

SAINT-GOBAIN PN	HONEYWELL PN	FINAL TOPCOAT COLOR
5249-200-V1	SCD-90401395-01	BAC7067 GLOSS WHITE

NOTES:

1. PART TRIM REQUIREMENTS ARE DEFINED ON DRAWING 5249-002.
2. ATTACHMENT HOLES PER CNC MACHINING OR FIXTURE J-9348.
3. INSTALL DIVERTERS PER SOP-304.
4. ATTACH I.D. LABEL ON INSIDE SURFACE APPROXIMATELY AS SHOWN.
5. APPLY FILLERS, PRIMERS AND PAINTS, ITEMS 17 THRU 21, PER SOP-200 AND SHEET 4 OF THIS DRAWING.
6. BRUSH PAINT RED THE HEAD OF SCREW ITEM -12 AND WASHER ITEM -13 AND NUT ITEM -14 AT THE END OF AFT DIVERTER HOLE. THIS HARDWARE IS FOR SHIPPING ONLY AND IS TO BE REMOVED AND DISCARDED BY THE INSTALLER.

7. IT IS PERMISSIBLE TO USE LONGER OR SHORTER LENGTHS OF THE SPECIFIED ASSEMBLY FASTENERS TO ACCOMMODATE VARIATION OF LAMINATE MATERIAL THICKNESS. SCREWS TO HAVE A MIN OF 2, MAX OF 8, EXPOSED THREADS.
8. IT IS PERMISSIBLE TO USE TWO WASHERS ON THE NUT SIDE OF THE SCREW IF NEEDED FOR VARIATION IN SCREW SHANK LENGTH.
9. IT IS PERMISSIBLE TO USE BMS 10-21 TY 2 (B0011428) AS AN ALTERNATE ANTI-STATIC PAINT.
10. WEIGHT TO BE 53.5 LBS MAX.
11. ALTERNATE COLOR SEGMENTED LIGHTNING DIVERTERS ACCEPTABLE. ALL SEGMENTED DIVERTERS MUST BE COMMON COLOR ON RADOME ASS'Y.

ITEM	ALT. PART NO.	COLOR
-4	B0015654	WHITE
-5	B0015695	WHITE
-6	B0015555	WHITE

ID-627805 E90401395-1-D

Figure 4-32. (Sheet 1 of 6) Fuselage Mount Radome Outline and Installation Drawing (90401395, REV D)

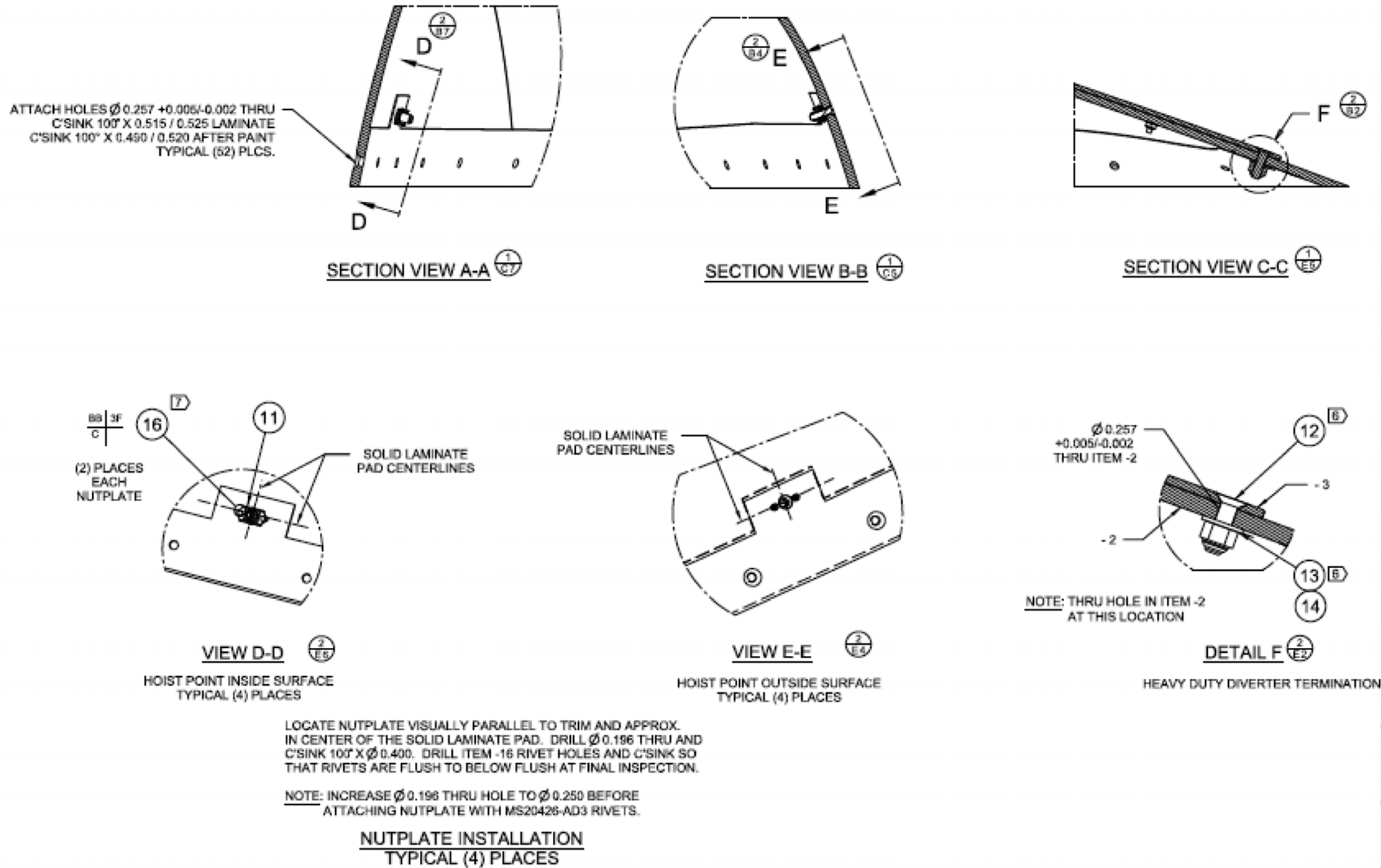

Figure 4-32. (Sheet 2 of 6) Fuselage Mount Radome Outline and Installation Drawing (90401395, REV D)

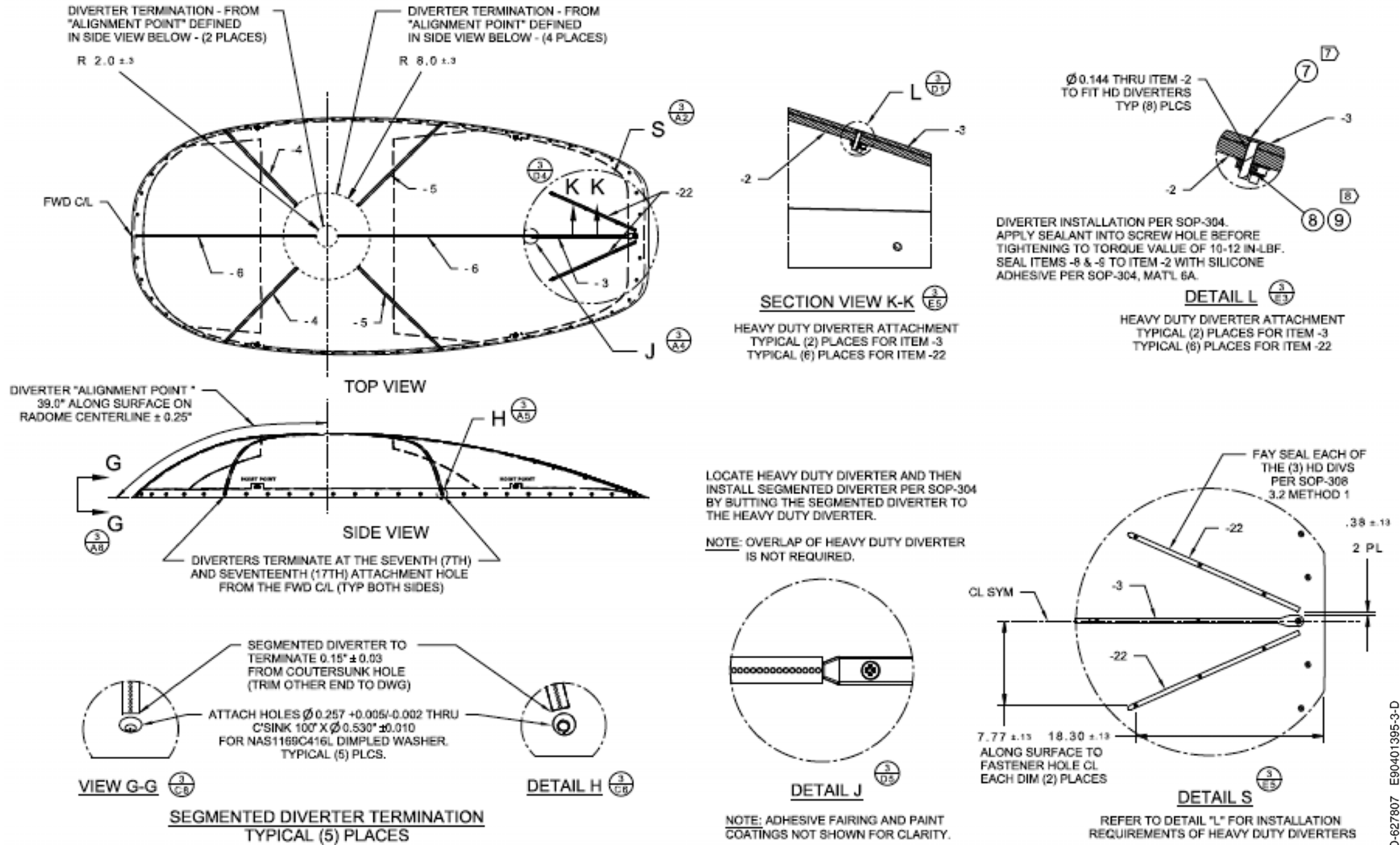

Figure 4-32. (Sheet 3 of 6) Fuselage Mount Radome Outline and Installation Drawing (90401395, REV D)

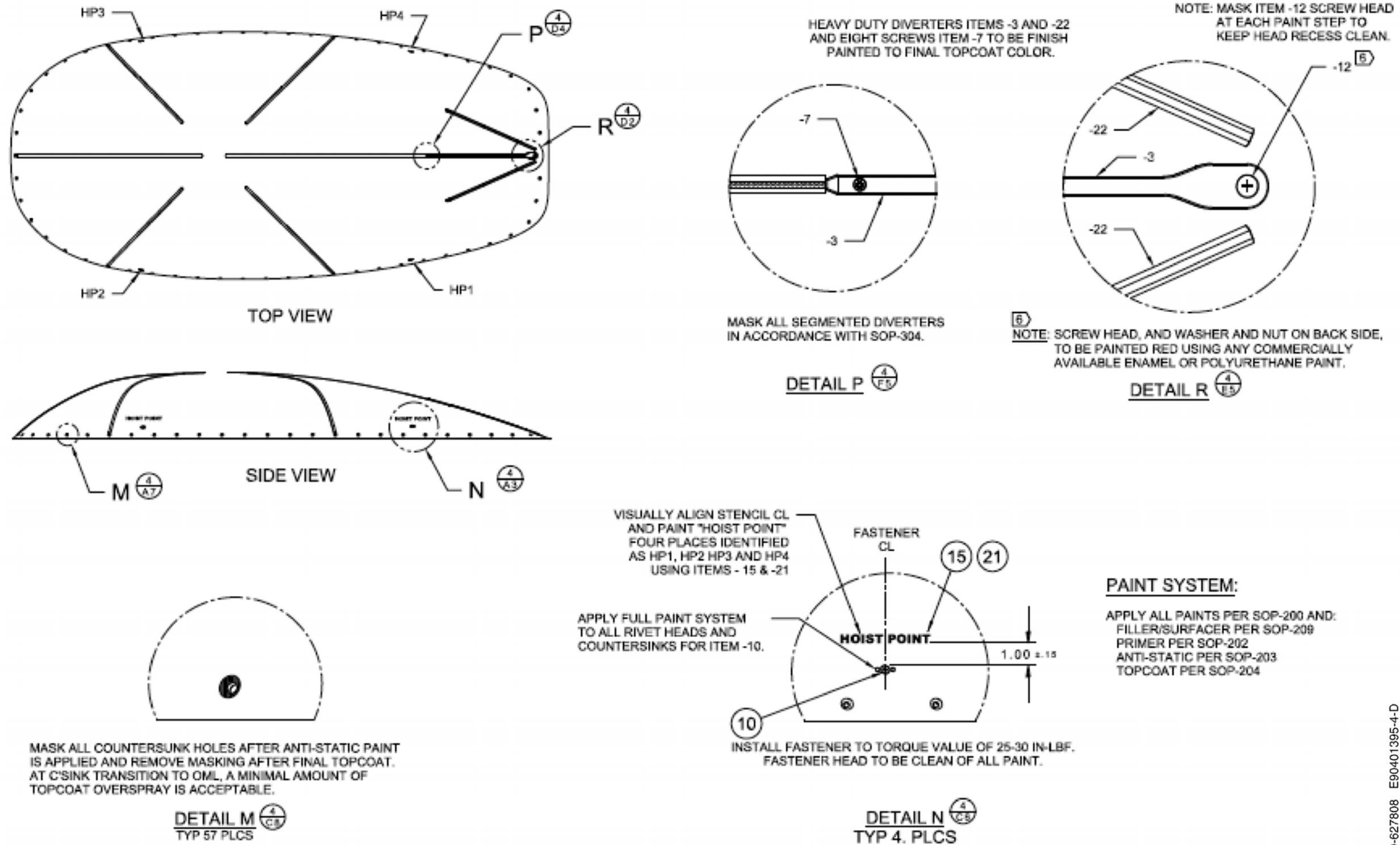
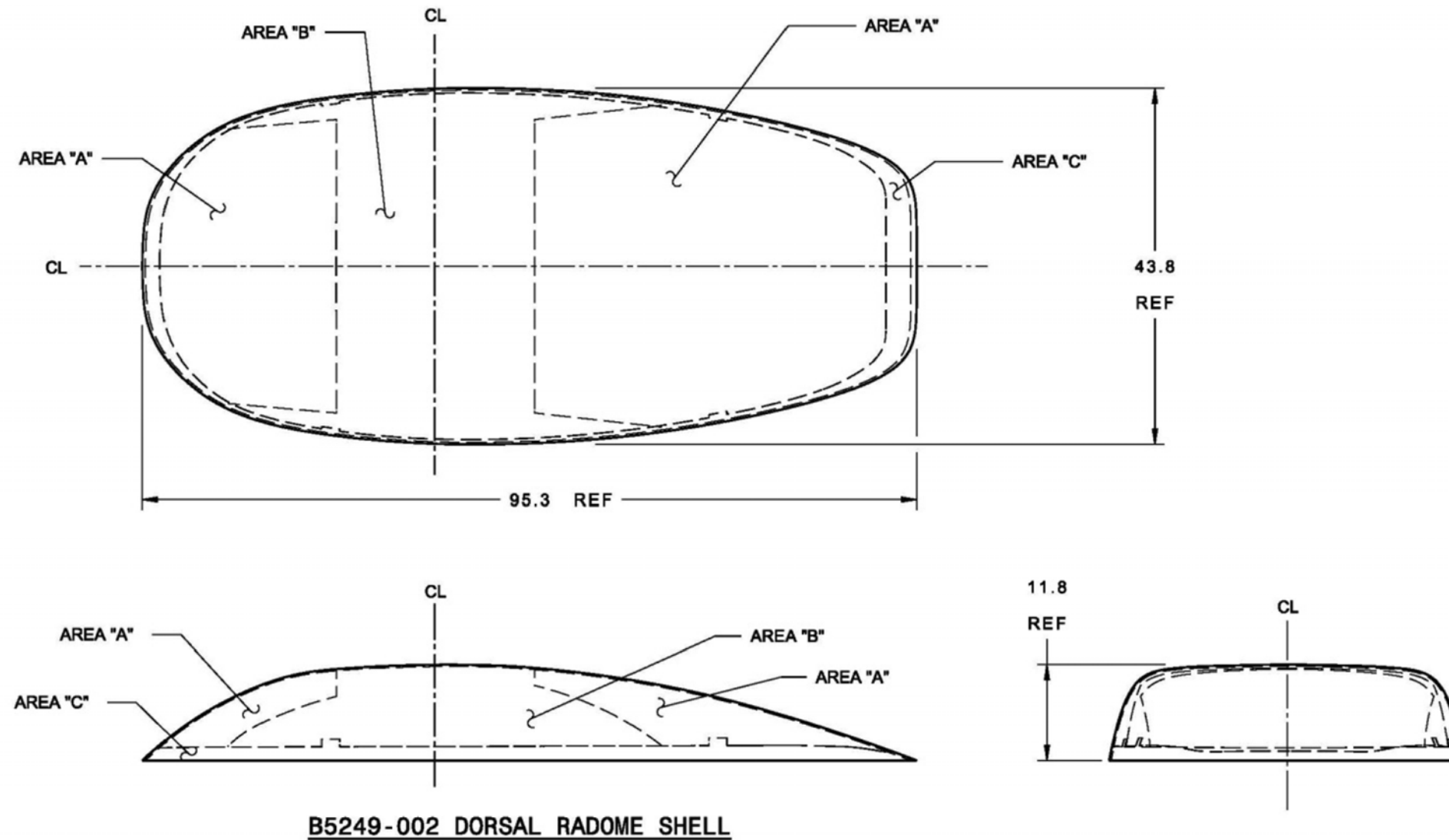

Figure 4-32. (Sheet 4 of 6) Fuselage Mount Radome Outline and Installation Drawing (90401395, REV D)



B5249-002 DORSAL RADOME SHELL

NOTES:

- 1 MANUFACTURE PER FAA APPROVED PS-200 (PROCESS SPECIFICATION.)
- 2 CONTOUR PER MOLD M-9850 AND CORE LOCATION PER TEMPLATE T-9881.
- 3 PLY LAP LOCATIONS FOR OUTER SKIN PER TEMPLATE T-9880.
- 4 AREA "B" LOCATION ON MIDDLE SKIN PER TEMPLATE T-9882.
- 5 CNC TRIM USING FIXTURE J-9348. OPTIONAL HAND TRIM TO MOLD LINE.
INSPECT TRIM TO IR-5249-100 OR ASSEMBLE TO ATTACHMENT RING AND
VERIFY A 0.070 TO 0.130 GAP
- 6 ALTERNATE PREPREG (ONE-SIDE COATED) PERMISSABLE AS NECESSARY
DURING LAY-UP OF MATERIALS.
- 7 ALL THICKNESS MEASUREMENTS ON BARE LAMINATE - IE: NO PAINT.
- 8 DIMENSION ALONG INNER SURFACE AS IN-PROCESS CHECK DURING LAY-UP.

AREA	CONSTRUCTION	TOTAL THK
A	SANDWICH	0.200 - 0.240
B	SANDWICH	0.190 - 0.230
C	EDGEBAND	0.240 - 0.260

ID-627809 E90401395-5-D

Figure 4-32. (Sheet 5 of 6) Fuselage Mount Radome Outline and Installation Drawing (90401395, REV D)

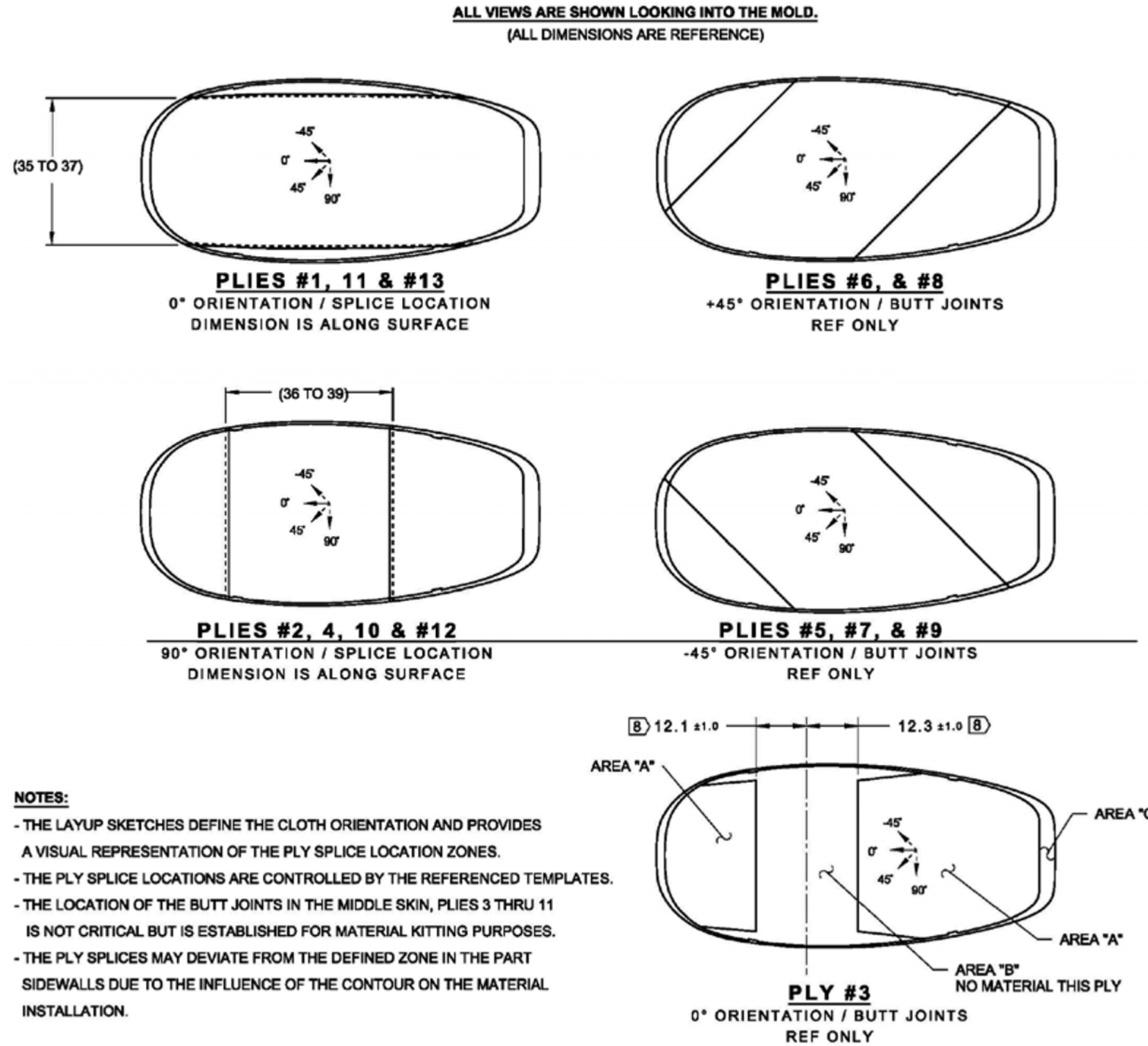

LAY-UP SEQUENCE:

- 1 PLY OF ITEM -2 (ADHESIVE FILM) FULL
- OUTER SKIN PLY LAPS ARE PER TEMPLATE T-9880
- PLY #1, ITEM 3 (15155) FULL, 0° WARP
- ⑥ - PLY #2, ITEM 3 (15155) FULL, 90° WARP
- 1 PLY ITEM 4, (7781) EDGE BAND AREA "C", -45° WARP
- 1 PLY ITEM 4, (7781) EDGE BAND AREA "C", +45° WARP
- 1 PLY ITEM 4, (7781) EDGE BAND AREA "C", -45° WARP
- INSTALL CORE, ITEM -5, CORE AREA "A" & "B" PER T-9881
- NOTE: MIDDLE SKIN PLY #3 AREA "B" PER TEMPLATE T-9882
- PLY #3, ITEM 3 (15155) FULL, 0° WARP (NOT A FULL PLY)
- PLY #4, ITEM 3 (15155) FULL, 90° WARP
- PLY #5, ITEM 3 (15155) FULL, -45° WARP
- PLY #6, ITEM 3 (15155) FULL, +45° WARP
- PLY #7, ITEM 3 (15155) FULL, -45° WARP
- PLY #8, ITEM 3 (15155) FULL, +45° WARP
- PLY #9, ITEM 3 (15155) FULL, -45° WARP
- PLY #10, ITEM 3 (15155) FULL, 90° WARP
- ⑥ - PLY #11, ITEM 3 (15155) FULL, 0° WARP
- 1 PLY ITEM 4, (7781) EDGE BAND AREA "C", +45° WARP
- 1 PLY ITEM 4, (7781) EDGE BAND AREA "C", -45° WARP
- 1 PLY ITEM 4, (7781) EDGE BAND AREA "C", +45° WARP
- 1 PLY ITEM 4, (7781) EDGE BAND AREA "C", -45° WARP
- INSTALL CORE, ITEM -5, CORE AREA "A" & "B"
- PLY #12, ITEM 3 (15155) FULL, 90° WARP
- PLY #13, ITEM 3 (15155) FULL, 0° WARP
- 1 PLY ITEM 4, (7781) EDGE BAND AREA "C", +45° WARP
- 1 PLY ITEM 4, (7781) EDGE BAND AREA "C", -45° WARP
- 1 ADJUSTMENT PLY ITEM 4, (7781) EDGE BAND AREA "C", +45° WARP



NOTES:

- THE LAYUP SKETCHES DEFINE THE CLOTH ORIENTATION AND PROVIDES A VISUAL REPRESENTATION OF THE PLY SPLICE LOCATION ZONES.
- THE PLY SPLICE LOCATIONS ARE CONTROLLED BY THE REFERENCED TEMPLATES.
- THE LOCATION OF THE BUTT JOINTS IN THE MIDDLE SKIN, PLYS 3 THRU 11 IS NOT CRITICAL BUT IS ESTABLISHED FOR MATERIAL KITTING PURPOSES.
- THE PLY SPLICES MAY DEVIATE FROM THE DEFINED ZONE IN THE PART SIDEWALLS DUE TO THE INFLUENCE OF THE CONTOUR ON THE MATERIAL INSTALLATION.

Figure 4-32. (Sheet 6 of 6) Fuselage Mount Radome Outline and Installation Drawing (90401395, REV D)

SYSTEM DESCRIPTION AND INSTALLATION MANUAL JetWave™ System

NOTES: UNLESS OTHERWISE SPECIFIED

1. DRAWING STANDARDS:
INTERPRET DRAWING PER ASME Y14.100-2000.
DIMENSIONING AND TOLERANCING PER ASME Y14.5-2009.
UNLESS OTHERWISE SPECIFIED DIMENSIONS ARE IN INCHES.
TOLERANCES ON:
 - .X +/- .2
 - .XX +/- .03
 - .XXX +/- .010
 - ∠ X, +/- 3°
 - ∠ .X +/- .5°
2. DIMENSIONS SHOWN ARE FOR INSTALLATION PURPOSES ONLY.
DIMENSIONS INDICATED ARE APPLICABLE TO BARE METAL PARTS AND DO NOT INCLUDE PRIMER PAINT THICKNESS.
3. WEIGHT 45.0 LBS MAX.
4. ASSOCIATED CAD DATA HAS BEEN MODELED TO NOMINAL DIMENSIONS.
PLACEMENT OF COMPONENTS IN CAD IS APPROXIMATE.
FINAL PLACEMENT AND INSTALLATION OF KIT COMPONENTS IS THE RESPONSIBILITY OF THE INSTALLER
5. COMPONENTS AS SHOWN ARE NOT ASSEMBLED. COMPONENTS COME BAGGED AND TAGGED IN KIT FORM.
COMPONENTS ASSEMBLY AND INSTALLATION ARE THE RESPONSIBILITY OF THE INSTALLER.
NOTE: PILOT HOLES FOR ALL KIT COMPONENTS ARE NOT PRE-DRILLED AND ARE THE RESPONSIBILITY OF THE INSTALLER.
STANDARD AEROSPACE INSTALLATION PRACTICES SHALL BE FOLLOWED.
SEE MATERIAL AND FINISH LISTS INDICATED ON THIS DRAWING.
6.  INDICATES APPROXIMATE CENTRE OF GRAVITY (REFERENCE ONLY).
7.  SEE TABLE 1 FOR COMPONENT LIST.
8. SCD-90403553 KIT IS BAGGED AND TAGGED WITH A LABEL THAT INCLUDES:
 - HONEYWELL NAME
 - HONEYWELL PART NUMBER
 - HONEYWELL REVISION
 - HONEYWELL CAGE CODE
 - SUPPLIER NAME
 - SUPPLIER PART NUMBER
 - SUPPLIER REVISION
 - DATE OF MANUFACTURE
 - COUNTRY OF MANUFACTURE
9.  AFTER INSTALLING WAVEGUIDE, APPLY MIL-A-46146 RTV SEALANT TO BRIDGE GAP BETWEEN FLEXIBLE PORTIONS OF WAVEGUIDES AND SHEET METAL BRACKET SUPPORTS. FULL COVERAGE ON PROJECTED AREA.
APPLICATION AND CURING PER MANUFACTURERS RECOMMENDATIONS.
10. ITEM 1 AND 2 MATERIAL:
ALUM ALLOY 7075-T651 PER AMS 4045, 7075-T62 PER AMS 4044,
7075-T7351 PER AMS 4078, 7050-T7451 PER AMS 4050, OR
7050-T7651 PER AMS 4201

ITEM 1 AND 2 FINISH:
GOLD CHEM FILM PER MIL-C-5541, CLASS 1A
PRIMED WITH MIL-PRF-23377, TYPE I PRIMER
(ALTERNATE PRIMER BMS 10-11, TYPE I, CLASS A)
11. ITEMS 3 TO 7 MATERIAL:
ALUM ALLOY 2024-T3/-T3510/-T3511 EXTRUSION, OR 7075-T7351 PLATE,
OR 7075-T73/-T73510/-T73511, OR 7075-T76/-T76510/-T76511

ITEMS 3 TO 7 FINISH:
CLEAR CHEM FILM PER MIL-DTL-5541, TYPE II, CLASS 3
PRIME USING 2 COATS MIL-PRF-23377, TYPE I, CLASS N PRIMER
(ALT PRIMER: BMS 10-11, TYPE I, CLASS A OR B)
12. ITEMS 8 TO 10 MATERIAL:
ALUM ALLOY 6061-T4, OR 6013-T4

ITEMS 8 TO 10 FINISH:
CLEAR CHEM FILM PER MIL-DTL-5541, TYPE II, CLASS 3
PRIME USING 2 COATS MIL-PRF-23377, TYPE I, CLASS N PRIMER
(ALT PRIMER: BMS 10-11, TYPE I, CLASS A OR B)

TABLE 1: COMPONENT LIST FOR SCD-90403553 

SPARE NO.	QUANTITY	QUANTITY	QUANTITY	PART NUMBER	DESCRIPTION	MATERIAL/SPECIFICATION	ITEM NO.
	120-171501-102	120-171501-101	SCD-90403553				
	KIT PART NO.						
	2	10	-	NAS6604-13	BOLT, HEX HEAD	1/4-28 X 1.24 LG, CAD PL STL	26
	1	4	-	NAS1801-08-11	SCREW, HEX HEAD	#8-32 X .69 LG, CAD PL STL	25
	6	12	-	NAS1801-08-10	SCREW, HEX HEAD	#8-32 X .63 LG, CAD PL STL	24
	1	4	-	NAS1801-08-7	SCREW, HEX HEAD	#8-32 X .44 LG, CAD PL STL	23
	4	36	-	NAS1801-04-10	SCREW, HEX HEAD	#4-40 X .625 LG, CAD PL STL	22
	4	20	-	NAS1149D0432J	WASHER, FLAT	Ø1/4 X .032 THK, ALUM - COND. CHEM FILM/MIL-DTL-5541, CLASS 3	21
	7	19	-	NAS1149DN816K	WASHER, FLAT	#8 X .016 THK, ALUM - NON-COND. ANODIZED / MIL-A-8625, CLASS 2	20
	4	36	-	NAS1149DN416K	WASHER, FLAT	#4 X .016 THK, ALUM - NON-COND. ANODIZED / MIL-A-8625, CLASS 2	19
	3	19	-	MS35338-135	WASHER, LOCK-SPRING, HELICAL REGULAR (MEDIUM) SERIES	#4 X .03 THK, CRES PASSIVATED PER QQ-P-35	18
	7	19	-	MS21060L08	NUT PLATE, SELF LOCKING	#8-32, CRES DFL ON THREADED SURFS	17
	3	19	-	MS21060L04	NUT PLATE, SELF LOCKING	#4-40, CRES DFL ON THREADED SURFS	16
	2	10	-	MS21042L4	NUT, SELF LOCKING	.250-28, CAD PL STL DRY FILM LUBRICATED	15
	10	10	-	MS20426AD3-12	RIVET, SOLID FLUSH HEAD	Ø3/32 X .750 LONG, ALUM GC FILM / MIL-C-5541, CLASS 1A	14
	2	8	-	MS20426AD3-7-5	RIVET, SOLID FLUSH HEAD	Ø3/32 X .468 LONG, ALUM GC FILM / MIL-C-5541, CLASS 1A	13
	13	41	-	MS20426AD3-6-5	RIVET, SOLID FLUSH HEAD	Ø3/32 X .406 LONG, ALUM GC FILM / MIL-C-5541, CLASS 1A	12
	3	25	-	MS20426AD3-4	RIVET, SOLID FLUSH HEAD	Ø3/32 X .250 LONG, ALUM GC FILM / MIL-C-5541, CLASS 1A	11
	-	-	1	200-35885-01	SUPPORT, WAVEGUIDE	SEE NOTE 12	10
	-	-	1	200-35884-01	SUPPORT, WAVEGUIDE	SEE NOTE 12	9
	-	-	1	200-35883-01	SUPPORT, WAVEGUIDE	SEE NOTE 12	8
	-	-	1	200-35792-03	MOUNTING FLANGE HORZ SLOT WAVEGUIDE	SEE NOTE 11	7
	-	-	2	200-35792-01	MOUNTING FLANGE HORZ SLOT WAVEGUIDE	SEE NOTE 11	6
	-	-	1	200-35791-03	MOUNTING FLANGE VERT SLOT WAVEGUIDE	SEE NOTE 11	5
	-	-	1	200-35791-02	MOUNTING FLANGE VERT SLOT WAVEGUIDE	SEE NOTE 11	4
	-	-	3	200-35791-01	MOUNTING FLANGE VERT SLOT WAVEGUIDE	SEE NOTE 11	3
	-	-	1	200-35363-01	EXTENSION, KRFLU	SEE NOTE 10	2
	-	-	1	200-35356-101	LAIM ASSEMBLY	SEE NOTE 10	1
	-	N/A	1	120-171501-102	HARDWARE KIT, LOCAL ANTENNA INTERFACE MOUNT, NON ARINC 791, JETWAVE	-	-
	-	N/A	1	120-171501-101	KIT, LOCAL ANTENNA INTERFACE MOUNT, NON ARINC 791, JETWAVE	-	-
	-	N/A	N/A	SCD-90403553	KIT, LOCAL ANTENNA INTERFACE MOUNT (LAIM), JETWAVE, NON ARINC 791	-	-

ID-601445 E90404861-1-A

Figure 4-33. (Sheet 1 of 4) LAIM Outline and Installation Drawing (90404861, REV A)

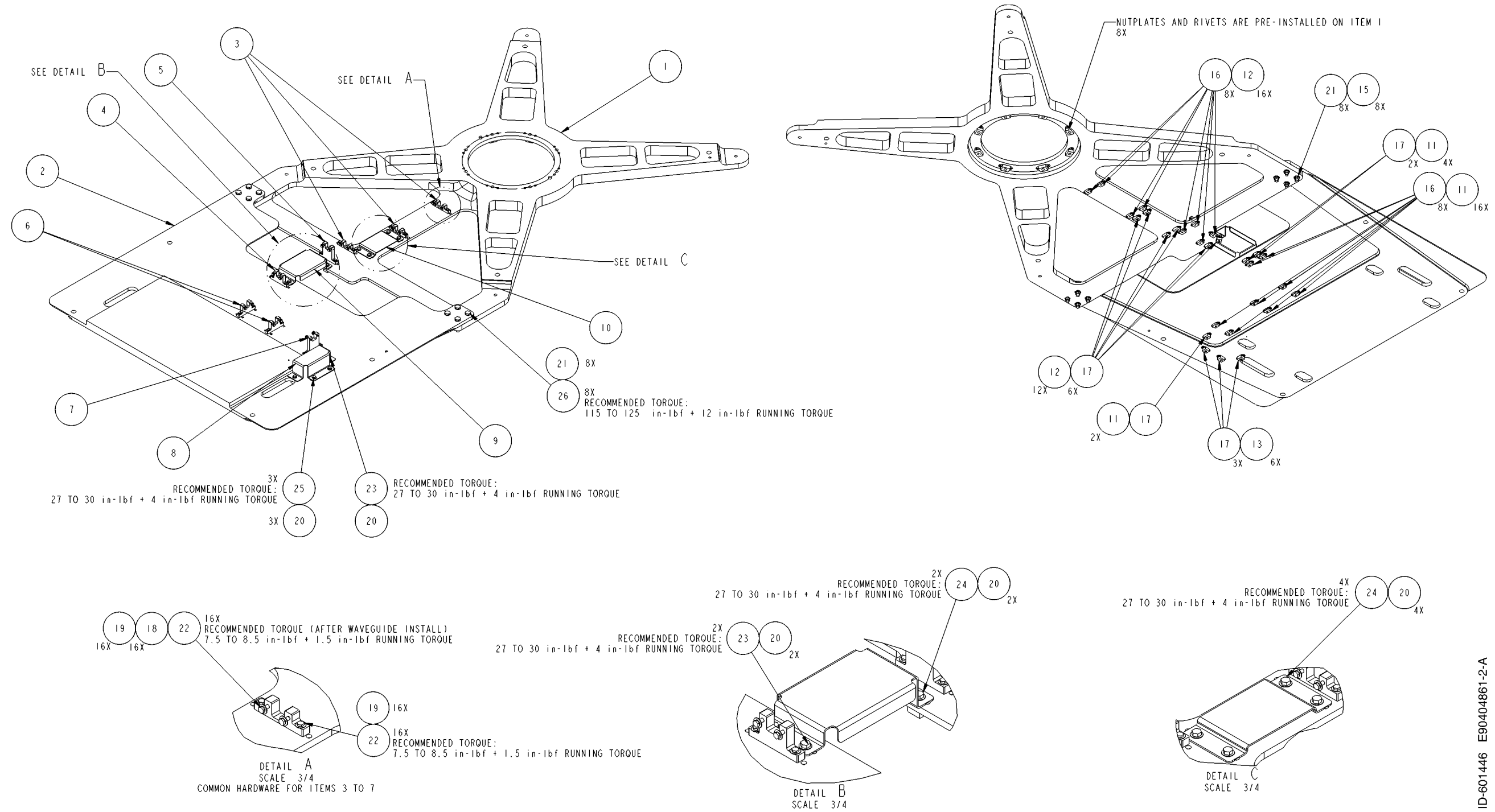
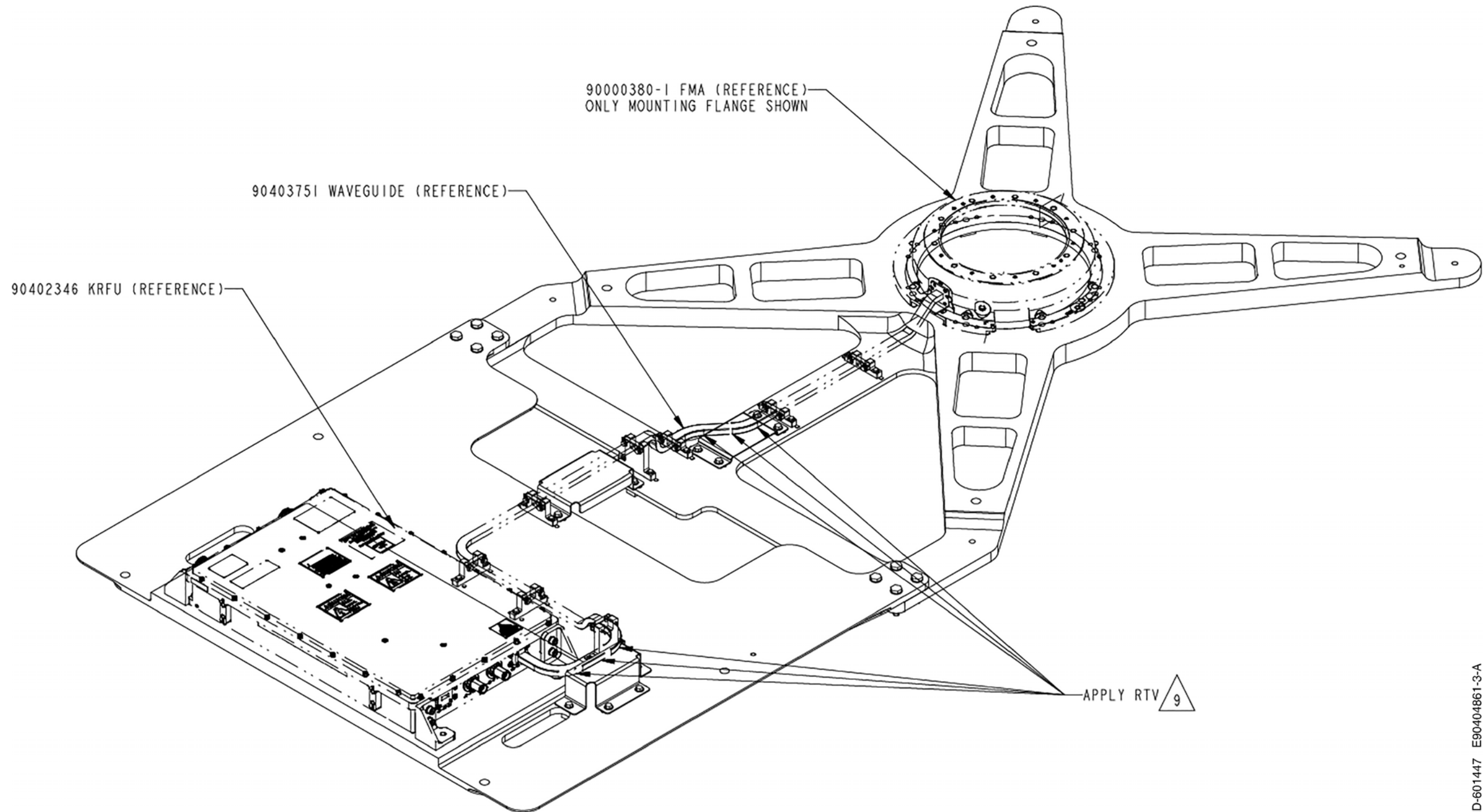
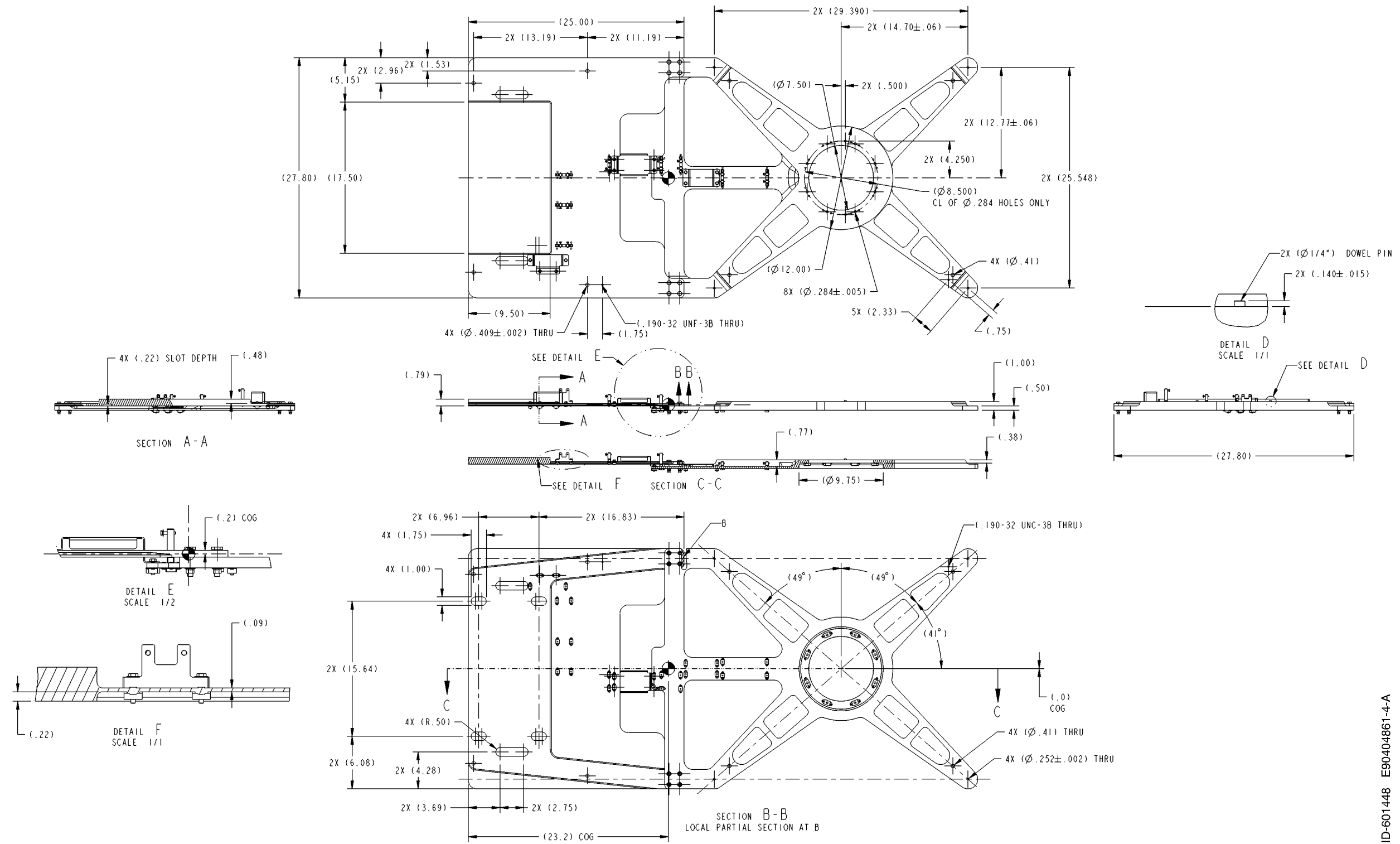

Figure 4-33. (Sheet 2 of 4) LAIM Outline and Installation Drawing (90404861, REV A)



ID-601447 E90404861-3-A

Figure 4-33. (Sheet 3 of 4) LAIM Outline and Installation Drawing (90404861, REV A)



SYSTEM DESCRIPTION AND INSTALLATION MANUAL JetWave™ System

NOTES, UNLESS OTHERWISE SPECIFIED:

- ALL CABLING SHOULD BE IN ACCORDANCE EITHER WITH *SAE A5508B1: WIRING AEROSPACE VEHICLE STANDARD* OR AS PER AIRFRAME MANUFACTURER'S REQUIREMENTS.
- WIRE SIZE RECOMMENDATIONS:
UNLESS OTHERWISE SPECIFIED ALL SIGNAL WIRES SHALL BE #24AWG.
 - RECOMMENDED TO USE SHIELDED TWISTED PAIR M27500G24SD2T23 OR EQUIVALENT.
 - RECOMMENDED TO USE SHIELDED TWISTED PAIR M27500G20SD2T23 OR EQUIVALENT FOR ANTENNA POWER, ANTENNA POWER RETURN, IMU POWER AND IMU POWER RETURN.
 - RECOMMENDED TO USE ARINC 664 COMPLIANT STAR QUAD CABLE FOR ETHERNET INTERFACES TERMINATING ON QUADRAX RECEPTACLES.
 - GXA LRU QUADRAX TERMINATIONS ARE WITH PIN TYPE CONTACTS.
 - ETHERNET STAR QUAD WIRE TERMINATIONS SHOULD NOT DISTORT NATURAL WIRE TWIST.
 - NO WIRES ARE TO BE LEFT EXPOSED OUTSIDE (TO THE REAR) OF QUADRAX CONTACT SHELL.
- UNLESS OTHERWISE STATED, ALL POWER, CHASSIS AND SIGNAL GROUNDS MUST NOT EXCEED 0.005 Ω.
- THE CHARACTERISTIC IMPEDANCE OF RS422 CABLES SHOULD MATCH RS422 DIFFERENTIAL SIGNAL TERMINAL IMPEDANCE REQUIREMENT OF 121 Ω ±10%.
- ALL CABLE SHIELDS SHOULD BE BONDED TO THE BACKSHELL OR CONNECTOR BODY.
- MATING PLUGS SHOULD BE NICKEL-PLATED ALUMINUM, NICKEL PLATED COMPOSITE OR STAINLESS STEEL.
- RF COAXIAL RECEPTACLES AND MATING CONNECTORS SHOULD BE NICKEL-PLATED BRASS.
- REFER TO PAGE 4 INTERCONNECTION DIAGRAM FOR KANDU INSTALLED IN UNPRESSURISED LOCATION INSIDE AIRCRAFT.
- REFER TO PAGE 5 INTERCONNECTION DIAGRAM FOR KANDU INSTALLED IN PRESSURISED LOCATION INSIDE AIRCRAFT.
- (A) 10/100 MBPS ETHERNET AND GIGABIT ETHERNET INTERFACES ARE PROVISIONED IN THE THREE VLAN TAGGED ISOLATED DOMAINS:
 - PASSENGER OWNED DEVICES DOMAIN (PODD).
 - PASSENGER INFORMATION AND ENTERTAINMENT SERVICES DOMAIN (PIESD) AND
 - AIRLINE INFORMATION SERVICES DOMAIN (AISD).
- EN3 ETHERNET INTERFACE OPERATE AT 10 MBPS.
- INSTALLER MAY SELECT APPROPRIATE DOMAIN ETHERNET INTERFACES TO MEET CONNECTIVITY REQUIREMENTS.
- ALL CABLE SHIELDS, EXCEPT ETHERNET SHIELDS TERMINATED TO QUADRAX CONTACTS, SHOULD BE TERMINATED TO A CONNECTOR BACKSHELL OR GROUNDING POINT DETERMINED BY THE AIRFRAME MANUFACTURER.
- ALL SHIELDED TWISTED PAIR WIRE FOR ETHERNET INTERFACE SHOULD BE OF 100 Ω CONTROLLED IMPEDANCE.
- STAR QUAD CABLES SHOULD BE USED FOR GIGABIT ETHERNET INTERCONNECTIONS. RECOMMENDED PIN DEFINITION AND COLOR SCHEME IS SHOWN BELOW.

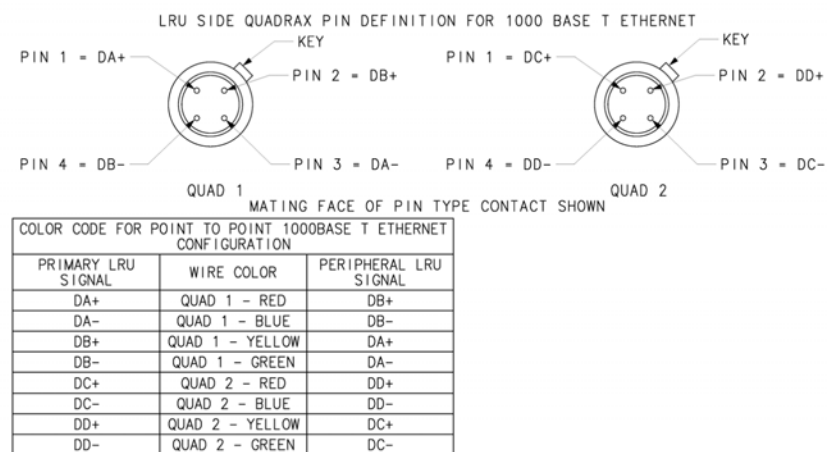

- SHIELDED TWISTED PAIR (2-PAIR) CABLES SHOULD BE USED FOR 10/100 MBPS ETHERNET INTERCONNECTIONS. RECOMMENDED PIN DEFINITIONS AND COLOR SCHEME IS SHOWN BELOW.

PRIMARY LRU SIGNAL	WIRE COLOR	PERIPHERAL LRU SIGNAL
TX +	RED	RX +
TX -	BLUE	RX -
RX +	YELLOW	TX +
RX -	GREEN	TX -

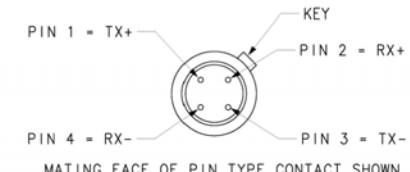

- (A) GXA LRUS OPERATE ON AIRCRAFT POWER SUPPLY OF 115 VAC (96 VRMS TO 122 VRMS WITH FREQUENCY RANGE OF MINIMUM 320 Hz TO 800 HZ).
- GXA DISCRETE SIGNALS ELECTRICAL SPECIFICATIONS ARE IN ACCORDANCE WITH ARINC SPECIFICATION 791/763 SECTION 2.9.6 AND 2.9.7, WITH MAXIMUM CONTROL VOLTAGE NOT EXCEEDING +36 VDC, GROUND (VALID) STATE DEFINED AS LESS THAN 3.5 VDC AND OPEN (INVALID) STATE DEFINED AS VOLTAGE LEVEL BETWEEN 18.5 TO 36 VDC OR RESISTANCE BETWEEN PIN AND AIRFRAME DC GROUND GREATER THAN 100 KΩ. THE MAXIMUM CURRENT FLOW IN THE STEADY STATE 'GROUND' STATE NOT TO EXCEED 20 MA.

- EMPTY CAVITY CONTACTS ARE INSTALLED BUT NO ELECTRICAL CONNECTIONS.

- DENOTES TWISTED PAIR (TP).
 DENOTES TWISTED SHIELDED PAIR (TSP).
 DENOTES SHIELDED TWISTED CABLE (2 PAIR).

- DENOTES OVERBRAID.
 DENOTES QUADRAX TERMINATION WITH STAR QUAD WIRING.
 DENOTES QUADRAX CABLE/SHIELDED TWISTED PAIR.

- DENOTES CHASSIS GROUND.
 DENOTES RECTANGULAR WAVEGUIDE.
 DENOTES FLEX/TWIST WAVEGUIDE.
 DENOTES POWER CABLE.

- AIRPLANE PERSONALITY MODULE (APM)
 - CABLE LENGTH BETWEEN MODMAN AND APM SHALL NOT EXCEED 3 METERS.
 - RECOMMEND TO USE 0.164-32 UNC-2A CORROSION RESISTANT MOUNTING FASTENERS. MOUNTING SCREWS TORQUE SHOULD NOT EXCEED 25 IN-LBS.
 - APM RECEPTACLE A2J1 IS MIL-DTL-38999/20FB35PN, SERIES III, SHELL SIZE 11 (B) WITH INSERT 11-35 (13 PIN). MATES WITH D38999/26FB35SN OR EQUIVALENT.
 - APM DC BONDING RESISTANCE SHOULD NOT EXCEED 2.5 mΩ.
 - APM A2J1 CONNECTOR CONTACT ASSIGNMENTS SHOWN IN TABLE 1 (SHEET 8).
 - APM CAN OPERATE WITHOUT THE NEED OF ANY FORCED AIR COOLING.
 - APM BONDING RECOMMENDED THROUGH CONTACT BASE OF UNIT AND A BONDING CABLE.
 - APM TO MODMAN INTERCONNECT CABLE SHALL USE ARINC 664 COMPLIANT 2 SHIELDED TWISTED PAIR 24AWG (OR AEROSPACE GRADE SHIELDED CAT 5/CATE 5E MINIMUM). PART NO ECS 922404 OR EQUIVALENT.

(CONTINUED ON SHEET 2)

Figure 4-34. (Sheet 1 of 10) JetWave™ System Interconnect Diagram - TMA (90400189-0001, REV D)