



Test Report

Prepared for: **EMS Technologies Honeywell Satcom**

Model: **GXA**

Description: **KA Band Aviation Radio**

FCC ID: **K6KJETWAVE**

To

FCC Part 25

Date of Issue: **December 18, 2015**

On the behalf of the applicant:

EMS Technologies Honeywell Satcom
400 Maple Grove Rd
Ottawa, Ontario K2V 1B8

Attention of:

Harish Gopal
Ph: (613) 595-7557
E-Mail: harish.gopal@Honeywell.com

Prepared By
Compliance Testing, LLC
1724 S. Nevada Way
Mesa, AZ 85204
(480) 926-3100 phone / (480) 926-3598 fax
www.compliancetesting.com
Project No: p1580004

Greg Corbin
Project Test Engineer

This report may not be reproduced, except in full, without written permission from Compliance Testing.
All results contained herein relate only to the sample tested

Test Report Revision History

Revision	Date	Revised By	Reason for Revision
1.0	11/25/15	Greg Corbin	Original Document
2.0	12/2/15	Amanda Reed	Updated contact information; corrected model name & description
3.0	12/8/15	Greg Corbin	Updated TMA 110 – 150 GHz radiated emissions data Added Necessary Bandwidth calculations
4.0	12/14/15	Amanda Reed	Updated Emission Designator
5.0	12/14/15	Diana Williams	Corrected FCC ID
6.0	12/18/15	Greg Corbin	Updated Radiated Emission Test Data



Table of Contents

<u>Description</u>	<u>Page</u>
Standard Test Conditions and Engineering Practices	5
Test Result Summary.....	7
Conducted Output Power.....	8
Conducted Emissions Limitations (Mask).....	9
Emissions Limitations (radiated).....	14
Necessary Bandwidth Calculations (Occupied Bandwidth).....	24
Frequency Tolerance (Temperature Variation).....	25
Frequency Tolerance (Voltage Variation).....	26
Test Equipment Utilized	27

ILAC / A2LA

Compliance Testing, LLC, has been accredited in accordance with the recognized International Standard ISO/IEC 17025:2005. This accreditation demonstrates technical competence for a defined scope and the operation of a laboratory quality management system (refer joint ISO-ILAC-IAF Communiqué dated January 2009).

The tests results contained within this test report all fall within our scope of accreditation, unless noted in the table below.

Please refer to <http://www.compliancetesting.com/labscope.html> for current scope of accreditation.

Testing Certificate Number: **2152.01**



FCC Site Reg. #349717

IC Site Reg. #2044A-2

Non-accredited tests contained in this report:

N/A

Standard Test Conditions and Engineering Practices

Unless otherwise indicated, the procedures contained in ANSI C63.4-2009 were observed during testing.

Prior to testing, the EUT was tuned up in accordance with the manufacturer's alignment procedures. All external gain controls were maintained at the position of maximum and/or optimum gain throughout the testing.

Measurement results, unless otherwise noted, are worst case measurement.

Unless otherwise indicated in the specific measurement results, the ambient temperature was maintained within the range of 10° to 40°C (50° to 104°F) and the relative humidity levels were in the range of 10% to 90%.

Environmental Conditions		
Temperature (°C)	Humidity (%)	Pressure (mbar)
19.8 – 24.4	29.3 – 43.2	961.5 – 974.2

Test and Measurement Data

All tests and measurement data shown were performed in accordance with FCC Rules and Regulations, Volume II; Part 2 and the following individual Parts: FCC Part 25 Satellite Communications.

Prior to testing the EUT was tuned up in accordance with the manufacturer's alignment procedures. All external gain controls were maintained at the position of maximum and/or optimum gain throughout the testing.

Measurement results, unless otherwise noted, are worst case measurements.

EUT Description

Model: GXA

Description: KA Band Aviation Radio

Additional Information:

The EUT is an aircraft earth station installed in either the tail or fuselage of the airplane and used to provide Inmarsat Global Xpress Aviation data services.

EUT Operation during Tests

The EUT operates from 29 – 30 GHz using 3 types of modulation, QPSK, BPSK and 8PSK.

The EUT was controlled by 2 racks of equipment supplied and operated by the manufacturer.

The racks are referred to as Test Jigs by the manufacturer.

The EUT output is WR 28 waveguide. The manufacturer provided a 20 dB waveguide coupler and a 40 dB waveguide attenuator for a load.

The conducted measurements were measured at the coupled port of the coupler.

Radiated measurements were measured in an anechoic chamber with the transmitter connected to 2 types of antennas and into a termination.

Accessories:

Qty	Description	Manufacturer	Model	S/N
1	GXA V&V KRFU/KANDU Test Jig	Honeywell Aerospace Electronic Systems	P/N: 90402190 rev 1	N/A
1	GXA V&V MODMAN Test Jig	Honeywell Aerospace Electronic Systems	P/N: 90402791 Rev 1	N/A
1	TMA (Tail Mount Antenna)	Honeywell Aerospace Electronic Systems	P/N: 90400013-001	017
1	FMA (Fuselage Mount Antenna)	Honeywell Aerospace Electronic Systems	P/N: 90000380-1	0007

Cables: Configuration cables included with the test jigs.

Modifications: None

Test Result Summary

Specification	Test Name	Pass, Fail, N/A	Comments
25.204	Carrier Output Power (Conducted)	Pass	
25.202f	Unwanted Emissions (Transmitter Conducted)	Pass	
2.1053	Field Strength of Spurious Radiation	Pass	
25.202f	Emission Masks (Occupied Bandwidth)	Pass	
25.202d	Frequency Stability (Temperature Variation)	Pass	
25.202d	Frequency Stability (Voltage Variation)	Pass	

Conducted Output Power

Engineer: Greg Corbin

Test Date: 11/13/2015

Test Procedure

The EUT was connected to a Spectrum Analyzer via a 20 dB coupler. The spectrum analyzer channel power measurement tool was used to record the output power.

Per §25.204(c), there is no EIRP limit for earth stations with elevation angles > 5 degrees above the horizon.

Per the manufacturer, the EUT does not transmit at elevation angles < 5 degrees above the horizon.

EIRP is based on the antenna used and is addressed at the time of installation.

Test Setup

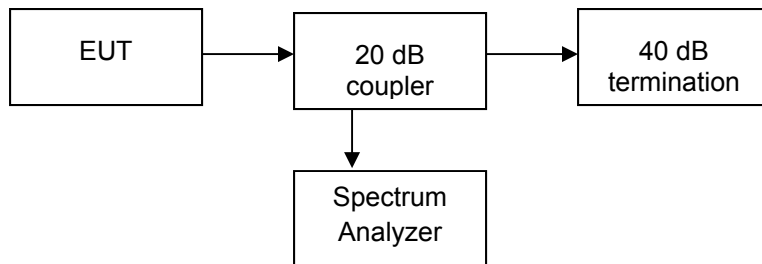

Transmitter Peak Output Power

Tuned Frequency (GHz)	Modulation	Recorded Measurement	Specification Limit	Result
29.0	QPSK	41.74	No limit for Aircraft Earth Stations	Pass
29.5	QPSK	40.76	No limit for Aircraft Earth Stations	Pass
30.0	QPSK	40.17	No limit for Aircraft Earth Stations	Pass
29.0	BPSK	41.42	No limit for Aircraft Earth Stations	Pass
29.5	BPSK	40.46	No limit for Aircraft Earth Stations	Pass
30.0	BPSK	39.83	No limit for Aircraft Earth Stations	Pass
29.0	8PSK	40.97	No limit for Aircraft Earth Stations	Pass
29.5	8PSK	39.51	No limit for Aircraft Earth Stations	Pass
30.0	8PSK	39.19	No limit for Aircraft Earth Stations	Pass

Conducted Emissions Limitations (Mask)

Engineer: Greg Corbin

Test Date: 11/13/2015

Test Procedure

The EUT was connected directly to a spectrum analyzer and the conducted spurious emissions were measured to ensure that the EUT met the requirements specified. Only the worst case emission at each frequency was reported. Notch and high pass filters were utilized to ensure that the fundamental power did not force the input of the spectrum analyzer into compressions. These losses in addition to cable losses were input into the analyzer as a reference level offset to ensure that accurate measurements were obtained.

Since the EUT output is WR 28 waveguide, the conducted emission limitations measurements were limited to the masks within the passband.

All other emission limitations were measured radiated, in an anechoic chamber with the 2 different types of antennas listed and a 50 ohm load.

Test Setup

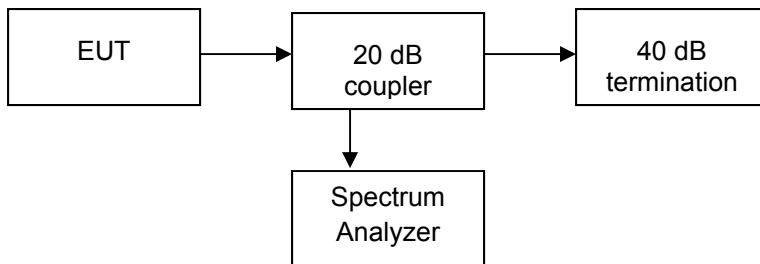

Emissions Limitations Plots at 29.0 GHz QPSK modulation

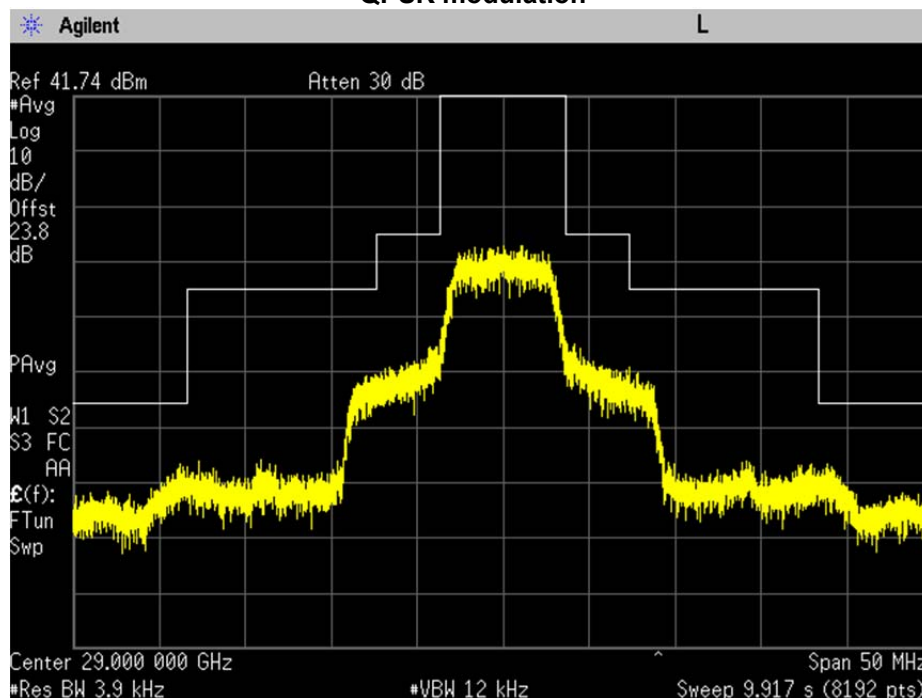



BPSK Modulation

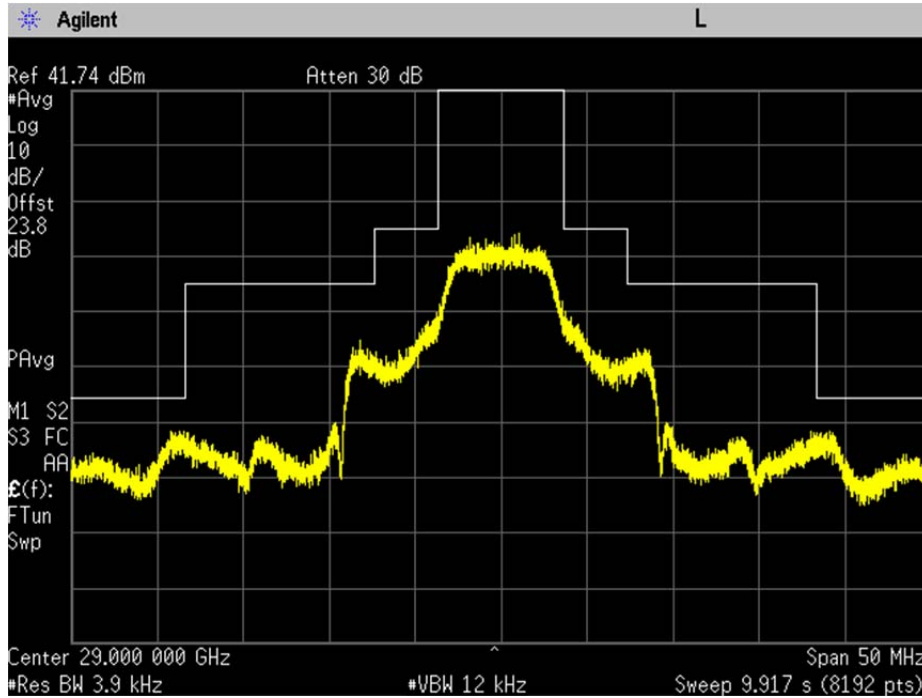

8PSK Modulation

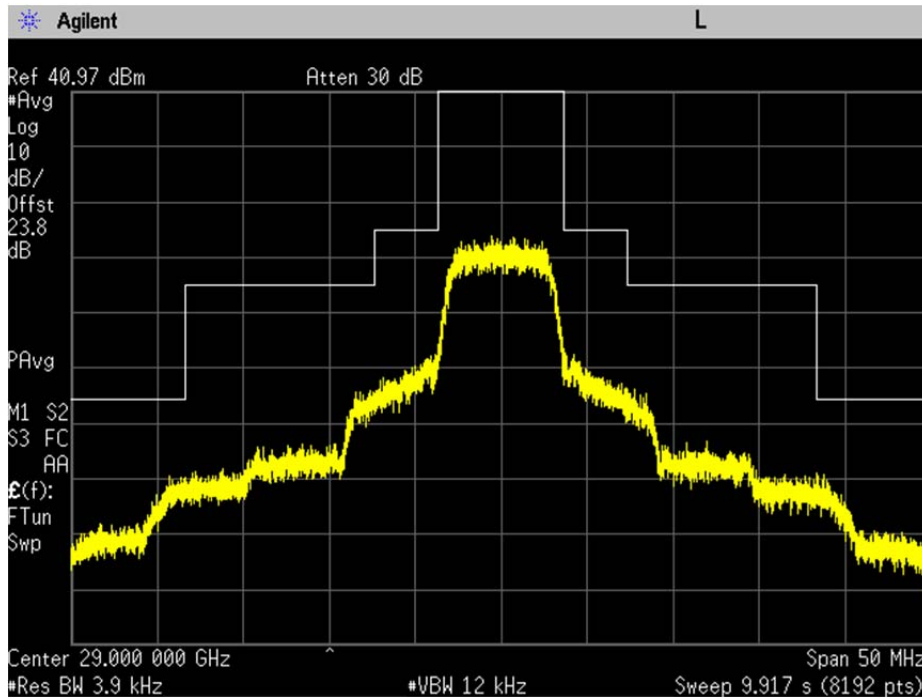



Emissions Limitations Plots at 29.5 GHz QPSK Modulation

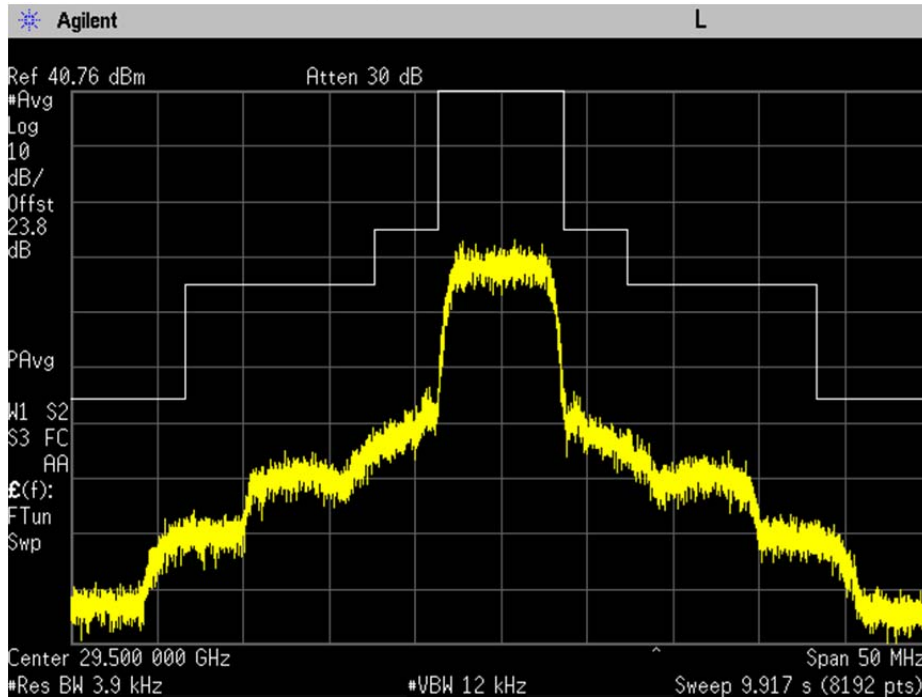

BPSK Modulation

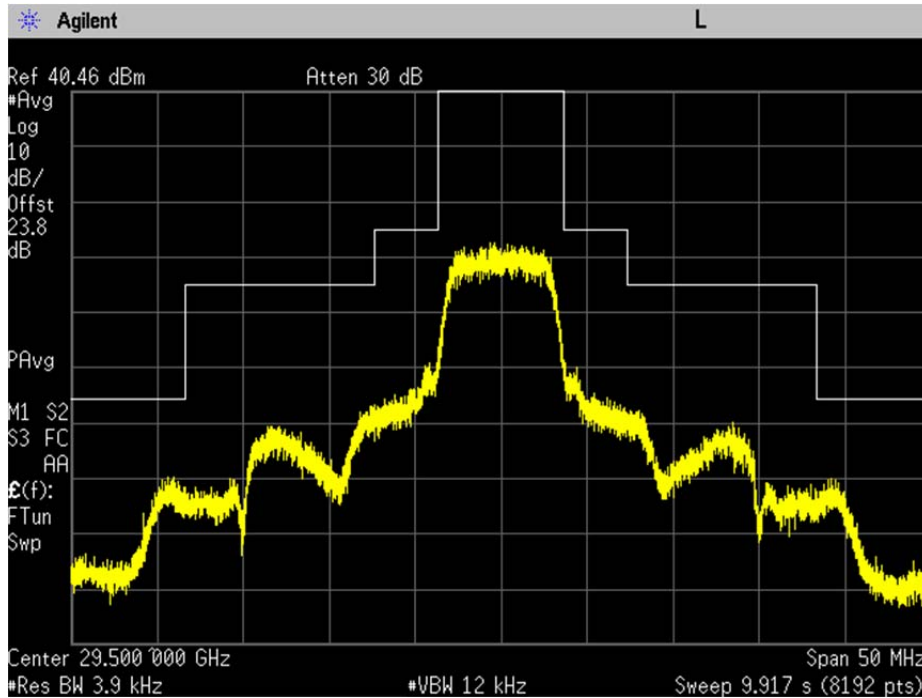



8PSK Modulation

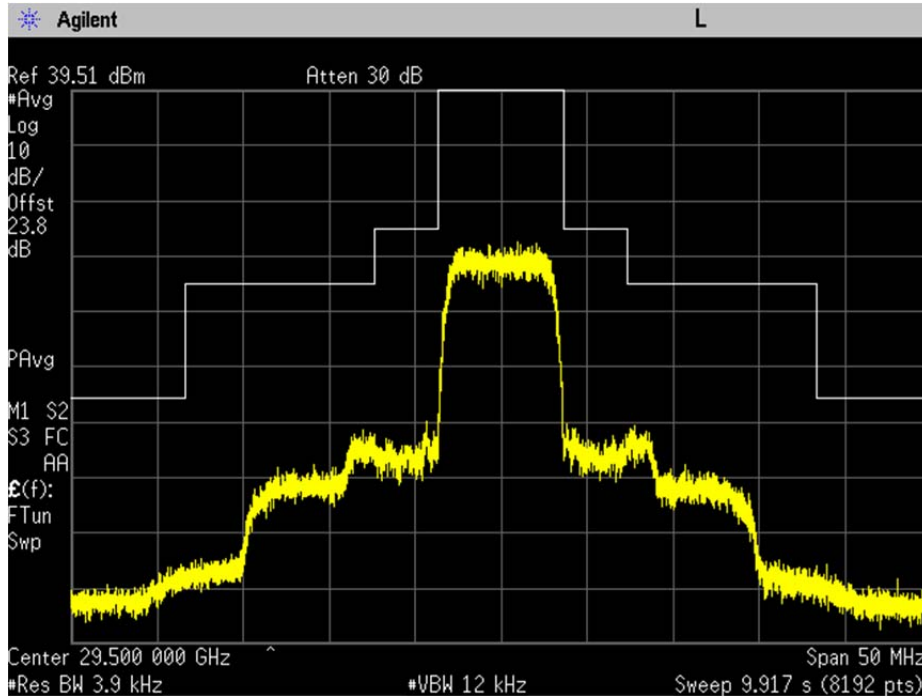

Emissions Limitations Plots at 30.0 GHz QPSK Modulation

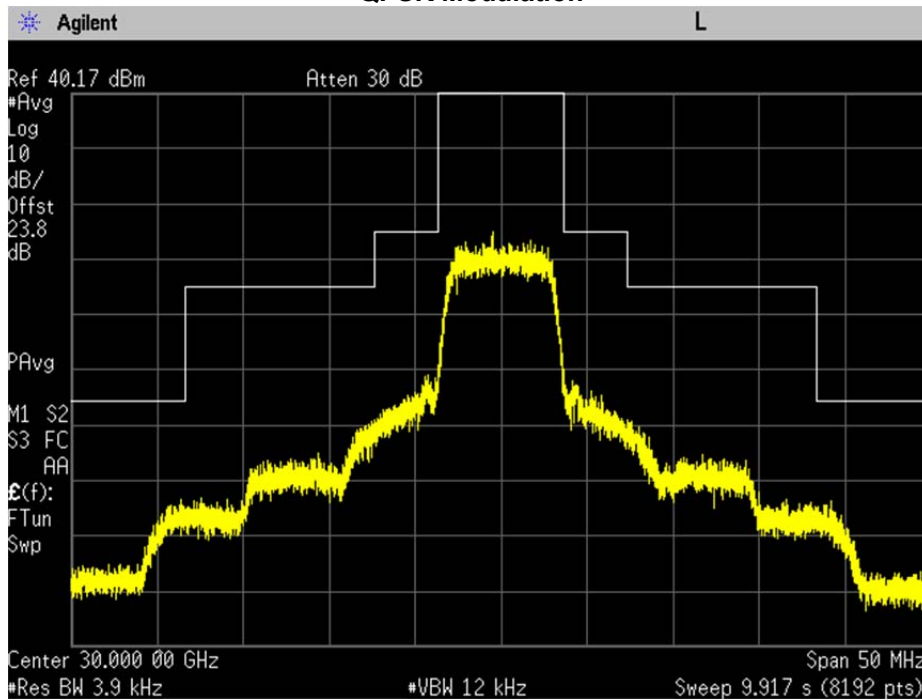



BPSK Modulation

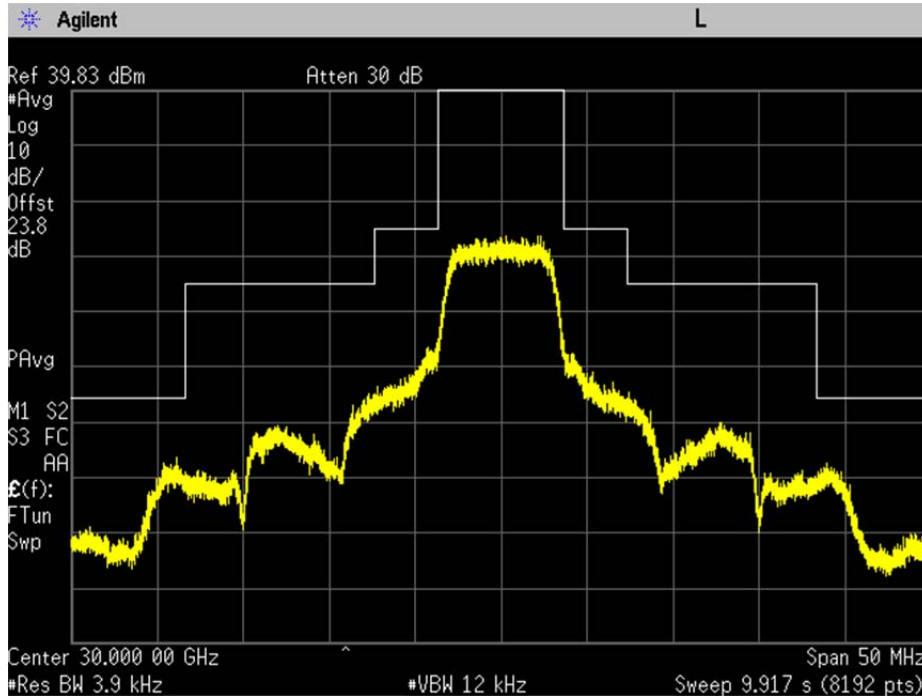

8PSK Modulation

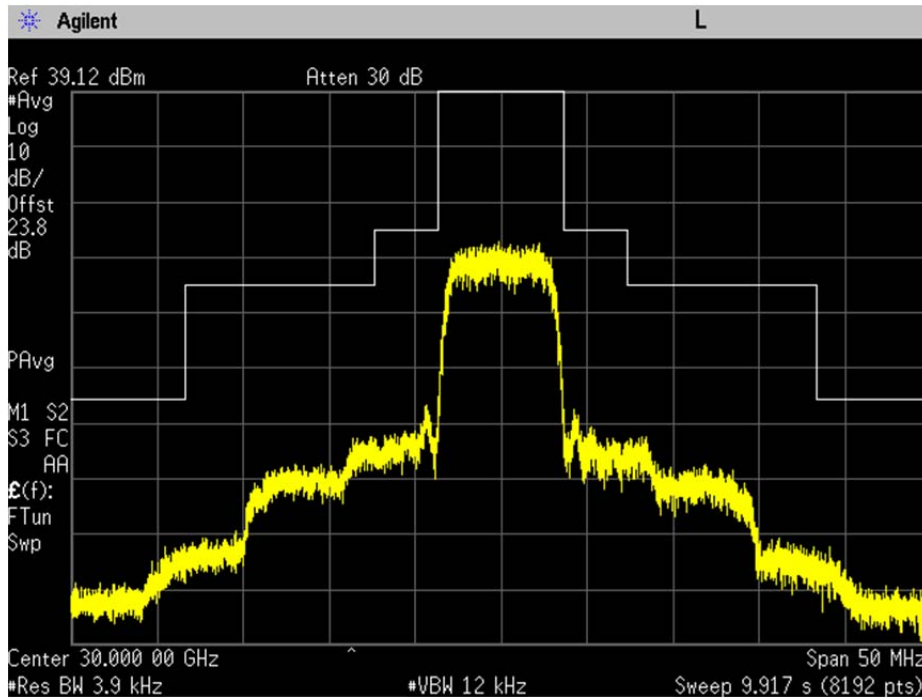

Emissions Limitations (radiated)

Engineer: Greg Corbin

Test Date: 11/17/2015

Test Procedure

Since the EUT output is WR 28 waveguide, the conducted emission limitations measurements were limited to the masks within the passband.

All other emission limitations were measured radiated, in an anechoic chamber with the 2 different types of antennas listed and a 50 ohm load.

Measurements were performed from 30 MHz to 150 GHz.

Harmonic mixers were utilized above 40 GHz.

The spurious emissions measurements were performed using all 3 modulations (QPSK, BPSK, 8PSK).

Calculations were used to compare the results to the -13 dBm limit.

1. All measurements are field strength measured at 1 meter except for 30 - 1000 MHz, which was measured at 3 meters.
2. For 30 - 1000 MHz, all correction factors were input to the spectrum analyzer before recording data.
3. Added receive correction factors (mixer and antenna) to field strength data.
4. Subtracted BW correction factor. BW specified = 4 kHz, BW measured = 30 KHz
5. Convert field strength (dBuV/m) to EIRP (dBm).
6. Compare result to -13 dBm conducted limit.
7. $BW \text{ Correction Factor} = 10 \cdot \text{LOG}(B1/B2)$
8. $\text{Field Strength (Calculated)} = \text{Raw Data} - BW \text{ Corr Factor} + RX \text{ Mixer Corr Factor} + RX \text{ Antenna Corr Factor}$
9. $\text{EIRP (dBm)} = \text{Field Strength (dBuV/m)} - 107$

Test Setup

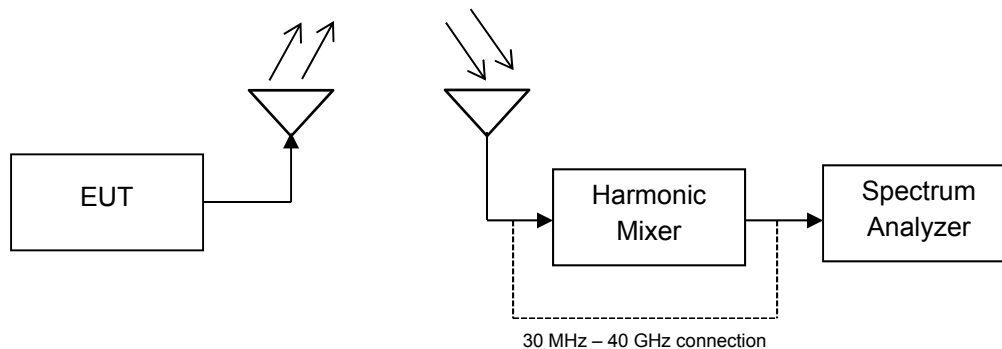

Emission Limitations (radiated) Test Data
FMA Antenna_Tuned Freq = 29 GHz_QPSK Modulation

Frequency Range	Test distance	Raw Data		BW Corr Factor	RX Mixer Corr Factor	RX Ant Corr Factor	Distance Corr Factor	Field Strength (Calculated)	Convert Field Strength to EIRP	Limit	Margin
		Freq	Level								
GHz	Meter	GHz	dBuV/m	dB	dB	dB	dB	dBuV/m	dBm	dBm	dB
0.03 -1	3	1	31.00	8.75	0.00	0.00	4.77	27.02	-79.98	-13	-66.98
1 - 18	1	13.75	24.50	8.75	0.00	40.30	0.00	56.05	-50.95	-13	-37.95
18 - 40	1	39.49	38.90	8.75	0.00	46.90	0.00	77.05	-29.95	-13	-16.95
40 - 50	1	40.9	0.95	8.75	23.40	39.14	0.00	54.74	-52.26	-13	-39.26
50 - 75	1	74.94	11.10	8.75	37.30	44.50	0.00	84.15	-22.85	-13	-9.85
75 - 110	0.1	85.68	23.60	8.75	42.10	45.77	-20.00	82.72	-24.28	-13	-11.28
110 - 150	0.1	110	-8.80	8.75	51.40	48.74	-20.00	62.59	-44.41	-13	-31.41

FMA Antenna_Tuned Freq = 29.5 GHz_QPSK Modulation

Frequency Range	Test distance	Raw Data		BW Corr Factor	RX Mixer Corr Factor	RX Ant Corr Factor	Distance Corr Factor	Field Strength (Calculated)	Convert Field Strength to EIRP	Limit	Margin
		Freq	Level								
GHz	Meter	GHz	dBuV/m	dB	dB	dB	dB	dBuV/m	dBm	dBm	dB
0.03 -1	3	0.97	32.00	8.75	0.00	0.00	4.77	28.02	-78.98	-13	-65.98
1 - 18	1	14.2	24.00	8.75	0.00	41.90	0.00	57.15	-49.85	-13	-36.85
18 - 40	1	39.56	38.20	8.75	0.00	46.90	0.00	76.35	-30.65	-13	-17.65
40 - 50	1	48.3	3.30	8.75	22.90	40.59	0.00	58.04	-48.96	-13	-35.96
50 - 75	1	50.44	12.70	8.75	35.50	40.97	0.00	80.42	-26.58	-13	-13.58
75 - 110	0.1	87.25	24.30	8.75	42.10	45.63	-20.00	83.28	-23.72	-13	-10.72
110 - 150	0.1	139.7	-5.90	8.75	55.90	50.81	-20.00	72.06	-34.94	-13	-21.94

FMA Antenna_Tuned Freq = 30 GHz_QPSK Modulation

Frequency Range	Test distance	Raw Data		BW Corr Factor	RX Mixer Corr Factor	RX Ant Corr Factor	Distance Corr Factor	Field Strength (Calculated)	Convert Field Strength to EIRP	Limit	Margin
		Freq	Level								
GHz	Meter	GHz	dBuV/m	dB	dB	dB	dB	dBuV/m	dBm	dBm	dB
0.03 -1	3	0.95	30.50	8.75	0.00	0.00	4.77	26.52	-80.48	-13	-67.48
1 - 18	1	13.89	24.10	8.75	0.00	40.90	0.00	56.25	-50.75	-13	-37.75
18 - 40	1	39.6	37.80	8.75	0.00	46.90	0.00	75.95	-31.05	-13	-18.05
40 - 50	1	42.64	1.50	8.75	23.10	39.41	0.00	55.26	-51.74	-13	-38.74
50 - 75	1	50.13	12.90	8.75	36.30	41.11	0.00	81.56	-25.44	-13	-12.44
75 - 110	0.1	88.74	23.10	8.75	41.80	45.87	-20.00	82.02	-24.98	-13	-11.98
110 - 150	0.1	145.2	-0.10	8.75	52.50	51.15	-20.00	74.80	-32.20	-13	-19.20

Emission Limitations (radiated) Test Data

FMA Antenna_Tuned Freq = 29 GHz_BPSK Modulation

Frequency Range	Test distance	Raw Data		BW Corr Factor	RX Mixer Corr Factor	RX Ant Corr Factor	Distance Corr Factor	Field Strength (Calculated)	Convert Field Strength to EIRP	Limit	Margin
		Freq	Level								
GHz	Meter	GHz	dBuV/m	dB	dB	dB	dB	dBuV/m	dBm	dBm	dB
0.03 - 1	3	1	30.00	8.75	0.00	0.00	4.77	26.02	-80.98	-13	-67.98
1 - 18	1	13.89	24.80	8.75	0.00	40.90	0.00	56.95	-50.05	-13	-37.05
18 - 40	1	39.78	37.90	8.75	0.00	47.00	0.00	76.15	-30.85	-13	-17.85
40 - 50	1	41.48	1.60	8.75	23.30	39.27	0.00	55.42	-51.58	-13	-38.58
50 - 75	1	50	12.40	8.75	36.30	40.99	0.00	80.94	-26.06	-13	-13.06
75 - 110	0.1	85.68	21.90	8.75	42.00	45.77	-20.00	80.92	-26.08	-13	-13.08
110 - 150	0.1	110	-8.90	8.75	51.40	48.74	-20.00	62.49	-44.51	-13	-31.51

FMA Antenna_Tuned Freq = 29.5 GHz_BPSK Modulation

Frequency Range	Test distance	Raw Data		BW Corr Factor	RX Mixer Corr Factor	RX Ant Corr Factor	Distance Corr Factor	Field Strength (Calculated)	Convert Field Strength to EIRP	Limit	Margin
		Freq	Level								
GHz	Meter	GHz	dBuV/m	dB	dB	dB	dB	dBuV/m	dBm	dBm	dB
0.03 - 1	3	0.95	31.00	8.75	0.00	0.00	4.77	27.02	-79.98	-13	-66.98
1 - 18	1	15.56	24.40	8.75	0.00	38.20	0.00	53.85	-53.15	-13	-40.15
18 - 40	1	39.74	37.90	8.75	0.00	46.90	0.00	76.05	-30.95	-13	-17.95
40 - 50	1	40	1.10	8.75	24.10	38.95	0.00	55.40	-51.60	-13	-38.60
50 - 75	1	50.44	11.20	8.75	35.60	40.97	0.00	79.02	-27.98	-13	-14.98
75 - 110	0.1	87.25	24.00	8.75	42.10	45.63	-20.00	82.98	-24.02	-13	-11.02
110 - 150	0.1	139.7	-6.10	8.75	56.00	50.81	-20.00	71.96	-35.04	-13	-22.04

FMA Antenna_Tuned Freq = 30 GHz_BPSK Modulation

Frequency Range	Test distance	Raw Data		BW Corr Factor	RX Mixer Corr Factor	RX Ant Corr Factor	Distance Corr Factor	Field Strength (Calculated)	Convert Field Strength to EIRP	Limit	Margin
		Freq	Level								
GHz	Meter	GHz	dBuV/m	dB	dB	dB	dB	dBuV/m	dBm	dBm	dB
0.03 - 1	3	0.95	31.50	8.75	0.00	0.00	4.77	27.52	-79.48	-13	-66.48
1 - 18	1	13.95	24.50	8.75	0.00	41.30	0.00	57.05	-49.95	-13	-36.95
18 - 40	1	39.71	36.80	8.75	0.00	46.90	0.00	74.95	-32.05	-13	-19.05
40 - 50	1	42.63	1.20	8.75	22.80	39.40	0.00	54.65	-52.35	-13	-39.35
50 - 75	1	73.31	13.90	8.75	36.30	44.41	0.00	85.86	-21.14	-13	-8.14
75 - 110	0.1	88.74	23.70	8.75	42.20	45.87	-20.00	83.02	-23.98	-13	-10.98
110 - 150	0.1	145.2	-0.60	8.75	52.50	51.15	-20.00	74.30	-32.70	-13	-19.70

Emission Limitations (radiated) Test Data
FMA Antenna_Tuned Freq = 29 GHz_8PSK Modulation

Frequency Range	Test distance	Raw Data		BW Corr Factor	RX Mixer Corr Factor	RX Ant Corr Factor	Distance Corr Factor	Field Strength (Calculated)	Convert Field Strength to EIRP	Limit	Margin
		Freq	Level								
GHz	Meter	GHz	dBuV/m	dB	dB	dB	dB	dBuV/m	dBm	dBm	dB
0.03 - 1	3	1	32.00	8.75	0.00	0.00	4.77	28.02	-78.98	-13	-65.98
1 - 18	1	15.51	24.70	8.75	0.00	38.40	0.00	54.35	-52.65	-13	-39.65
18 - 40	1	39.12	37.50	8.75	0.00	46.30	0.00	75.05	-31.95	-13	-18.95
40 - 50	1	44.03	1.10	8.75	23.70	39.78	0.00	55.83	-51.17	-13	-38.17
50 - 75	1	74.88	12.40	8.75	37.30	44.50	0.00	85.45	-21.55	-13	-8.55
75 - 110	0.1	85.68	23.10	8.75	42.10	45.77	-20.00	82.22	-24.78	-13	-11.78
110 - 150	0.1	110.7	-9.30	8.75	51.40	48.79	-20.00	62.14	-44.86	-13	-31.86

FMA Antenna_Tuned Freq = 29.5 GHz_8PSK Modulation

Frequency Range	Test distance	Raw Data		BW Corr Factor	RX Mixer Corr Factor	RX Ant Corr Factor	Distance Corr Factor	Field Strength (Calculated)	Convert Field Strength to EIRP	Limit	Margin
		Freq	Level								
GHz	Meter	GHz	dBuV/m	dB	dB	dB	dB	dBuV/m	dBm	dBm	dB
0.03 - 1	3	0.97	31.00	8.75	0.00	0.00	4.77	27.02	-79.98	-13	-66.98
1 - 18	1	13.81	24.30	8.75	0.00	40.50	0.00	56.05	-50.95	-13	-37.95
18 - 40	1	39.67	37.00	8.75	0.00	46.90	0.00	75.15	-31.85	-13	-18.85
40 - 50	1	40	1.20	8.75	24.10	38.95	0.00	55.50	-51.50	-13	-38.50
50 - 75	1	50.19	13.10	8.75	36.00	40.92	0.00	81.27	-25.73	-13	-12.73
75 - 110	0.1	87.25	25.20	8.75	42.10	45.63	-20.00	84.18	-22.82	-13	-9.82
110 - 150	0.1	139.7	-8.90	8.75	55.80	50.81	-20.00	68.96	-38.04	-13	-25.04

FMA Antenna_Tuned Freq = 30 GHz_8PSK Modulation

Frequency Range	Test distance	Raw Data		BW Corr Factor	RX Mixer Corr Factor	RX Ant Corr Factor	Distance Corr Factor	Field Strength (Calculated)	Convert Field Strength to EIRP	Limit	Margin
		Freq	Level								
GHz	Meter	GHz	dBuV/m	dB	dB	dB	dB	dBuV/m	dBm	dBm	dB
0.03 - 1	3	0.94	32.00	8.75	0.00	0.00	4.77	28.02	-78.98	-13	-65.98
1 - 18	1	13.69	25.30	8.75	0.00	40.30	0.00	56.85	-50.15	-13	-37.15
18 - 40	1	29.37	32.20	8.75	0.00	46.60	0.00	70.05	-36.95	-13	-23.95
40 - 50	1	49.15	7.70	8.75	22.30	40.64	0.00	61.89	-45.11	-13	-32.11
50 - 75	1	75	12.50	8.75	37.30	44.61	0.00	85.66	-21.34	-13	-8.34
75 - 110	0.1	90.66	23.70	8.75	42.10	46.06	-20.00	83.11	-23.89	-13	-10.89
110 - 150	0.1	142.1	-0.80	8.75	50.80	50.96	-20.00	72.21	-34.79	-13	-21.79



Emission Limitations (radiated) Test Data

TMA Antenna_Tuned Freq = 29 GHz_QPSK Modulation

Frequency Range	Test distance	Raw Data		BW Corr Factor	RX Mixer Corr Factor	RX Ant Corr Factor	Distance Corr Factor	Field Strength (Calculated)	Convert Field Strength to EIRP	Limit	Margin
		Freq	Level								
GHz	Meter	GHz	dBuV/m	dB	dB	dB	dB	dBuV/m	dBm	dBm	dB
0.03 -1	3	990.3	34.60	8.75	0	0.00	4.77	30.62	-76.38	-13	-63.38
1 - 18	1	14.175	23.60	8.75	0	41.80	0.00	56.65	-50.35	-13	-37.35
18 - 40	1	39.71	41.40	8.75	0	46.90	0.00	79.55	-27.45	-13	-14.45
40 - 50	1	43.95	21.30	8.75	23.7	39.77	0.00	76.02	-30.98	-13	-17.98
50 - 75	1	50.313	13.00	8.75	36.1	41.04	0.00	81.39	-25.61	-13	-12.61
75 - 110	0.1	87.6	30.40	8.75	42.2	45.96	-20.00	89.81	-17.19	-13	-4.19
110 - 150	0.1	126.2	6.10	8.75	60.8	49.93	-20.00	88.08	-18.92	-13	-5.92

TMA Antenna_Tuned Freq = 29.5 GHz_QPSK Modulation

Frequency Range	Test distance	Raw Data		BW Corr Factor	RX Mixer Corr Factor	RX Ant Corr Factor	Distance Corr Factor	Field Strength (Calculated)	Convert Field Strength to EIRP	Limit	Margin
		Freq	Level								
GHz	Meter	GHz	dBuV/m	dB	dB	dB	dB	dBuV/m	dBm	dBm	dB
0.03 -1	3	990.3	32.10	8.75	0	0.00	4.77	28.12	-78.88	-13	-65.88
1 - 18	1	13.948	24.60	8.75	0	41.10	0.00	56.95	-50.05	-13	-37.05
18 - 40	1	39.45	41.80	8.75	0	46.90	0.00	79.95	-27.05	-13	-14.05
40 - 50	1	40.175	21.60	8.75	24	38.99	0.00	75.84	-31.16	-13	-18.16
50 - 75	1	50.125	10.40	8.75	36.1	40.91	0.00	78.66	-28.34	-13	-15.34
75 - 110	0.1	89.175	31.10	8.75	41.9	45.81	-20.00	90.06	-16.94	-13	-3.94
110 - 150	0.1	126.2	5.90	8.75	60.8	49.93	-20.00	87.88	-19.12	-13	-6.12

TMA Antenna_Tuned Freq = 30 GHz_QPSK Modulation

Frequency Range	Test distance	Raw Data		BW Corr Factor	RX Mixer Corr Factor	RX Ant Corr Factor	Distance Corr Factor	Field Strength (Calculated)	Convert Field Strength to EIRP	Limit	Margin
		Freq	Level								
GHz	Meter	GHz	dBuV/m	dB	dB	dB	dB	dBuV/m	dBm	dBm	dB
0.03 -1	3	990.3	32.10	8.75	0	0.00	4.77	28.12	-78.88	-13	-65.88
1 - 18	1	13.722	24.30	8.75	0	40.40	0.00	55.95	-51.05	-13	-38.05
18 - 40	1	39.52	42.40	8.75	0	46.90	0.00	80.55	-26.45	-13	-13.45
40 - 50	1	44.925	20.90	8.75	22.9	39.86	0.00	74.91	-32.09	-13	-19.09
50 - 75	1	50.125	12.60	8.75	36.2	41.11	0.00	81.16	-25.84	-13	-12.84
75 - 110	0.1	88.738	26.50	8.75	41.8	45.87	-20.00	85.42	-21.58	-13	-8.58
110 - 150	0.1	126.2	6.40	8.75	60.8	49.93	-20.00	88.38	-18.62	-13	-5.62

Emission Limitations (radiated) Test Data
TMA Antenna_Tuned Freq = 29 GHz_BPSK Modulation

Frequency Range	Test distance	Raw Data		BW Corr Factor	RX Mixer Corr Factor	RX Ant Corr Factor	Distance Corr Factor	Field Strength (Calculated)	Convert Field Strength to EIRP	Limit	Margin
		Freq	Level								
GHz	Meter	GHz	dBuV/m	dB	dB	dB	dB	dBuV/m	dBm	dBm	dB
0.03 -1	3	990.3	31.30	8.75	0	0.00	4.77	27.32	-79.68	-13	-66.68
1 - 18	1	14.033	23.70	8.75	0	41.30	0.00	56.25	-50.75	-13	-37.75
18 - 40	1	39.78	42.60	8.75	0	47.10	0.00	80.95	-26.05	-13	-13.05
40 - 50	1	43.85	21.20	8.75	23.6	39.75	0.00	75.80	-31.20	-13	-18.20
50 - 75	1	50.125	20.70	8.75	36.2	41.01	0.00	89.16	-17.84	-13	-4.84
75 - 110	0.1	85.675	30.20	8.75	42	45.77	-20.00	89.22	-17.78	-13	-4.78
110 - 150	0.1	126.2	6.20	8.75	60.8	49.93	-20.00	88.18	-18.82	-13	-5.82

TMA Antenna_Tuned Freq = 29.5 GHz_BPSK Modulation

Frequency Range	Test distance	Raw Data		BW Corr Factor	RX Mixer Corr Factor	RX Ant Corr Factor	Distance Corr Factor	Field Strength (Calculated)	Convert Field Strength to EIRP	Limit	Margin
		Freq	Level								
GHz	Meter	GHz	dBuV/m	dB	dB	dB	dB	dBuV/m	dBm	dBm	dB
0.03 -1	3	990.3	31.70	8.75	0	0.00	4.77	27.72	-79.28	-13	-66.28
1 - 18	1	13.665	24.50	8.75	0	40.20	0.00	55.95	-51.05	-13	-38.05
18 - 40	1	39.6	42.50	8.75	0	46.90	0.00	80.65	-26.35	-13	-13.35
40 - 50	1	40.025	21.50	8.75	24.1	38.96	0.00	75.81	-31.19	-13	-18.19
50 - 75	1	50	13.00	8.75	34.9	40.89	0.00	80.04	-26.96	-13	-13.96
75 - 110	0.1	89.175	31.20	8.75	41.9	45.81	-20.00	90.16	-16.84	-13	-3.84
110 - 150	0.1	126.2	5.40	8.75	60.8	49.93	-20.00	87.38	-19.62	-13	-6.62

TMA Antenna_Tuned Freq = 30 GHz_BPSK Modulation

Frequency Range	Test distance	Raw Data		BW Corr Factor	RX Mixer Corr Factor	RX Ant Corr Factor	Distance Corr Factor	Field Strength (Calculated)	Convert Field Strength to EIRP	Limit	Margin
		Freq	Level								
GHz	Meter	GHz	dBuV/m	dB	dB	dB	dB	dBuV/m	dBm	dBm	dB
0.03 -1	3	985.5	32.10	8.75	0	0.00	4.77	28.12	-78.88	-13	-65.88
1 - 18	1	14.062	24.50	8.75	0	41.30	0.00	57.05	-49.95	-13	-36.95
18 - 40	1	39.63	42.10	8.75	0	46.90	0.00	80.25	-26.75	-13	-13.75
40 - 50	1	44.05	21.60	8.75	23.7	39.69	0.00	76.24	-30.76	-13	-17.76
50 - 75	1	50.188	13.10	8.75	36.2	41.12	0.00	81.67	-25.33	-13	-12.33
75 - 110	0.1	90.663	27.10	8.75	42.1	46.06	-20.00	86.51	-20.49	-13	-7.49
110 - 150	0.1	126.2	6.00	8.75	60.8	49.93	-20.00	87.98	-19.02	-13	-6.02



Emission Limitations (radiated) Test Data

TMA Antenna_Tuned Freq = 29 GHz_8PSK Modulation

Frequency Range	Test distance	Raw Data		BW Corr Factor	RX Mixer Corr Factor	RX Ant Corr Factor	Distance Corr Factor	Field Strength (Calculated)	Convert Field Strength to EIRP	Limit	Margin
		Freq	Level								
GHz	Meter	GHz	dBuV/m	dB	dB	dB	dB	dBuV/m	dBm	dBm	dB
0.03 -1	3	990.3	31.60	8.75	0	0.00	4.77	27.62	-79.38	-13	-66.38
1 - 18	1	13.637	24.00	8.75	0	40.20	0.00	55.45	-51.55	-13	-38.55
18 - 40	1	39.63	41.40	8.75	0	46.90	0.00	79.55	-27.45	-13	-14.45
40 - 50	1	40.6	21.20	8.75	23.6	39.08	0.00	75.13	-31.87	-13	-18.87
50 - 75	1	50.125	12.70	8.75	36.1	41.01	0.00	81.06	-25.94	-13	-12.94
75 - 110	0.1	87.688	31.50	8.75	42.2	45.97	-20.00	90.92	-16.08	-13	-3.08
110 - 150	0.1	126.2	6.20	8.75	60.8	49.93	-20.00	88.18	-18.82	-13	-5.82

TMA Antenna_Tuned Freq = 29.5 GHz_8PSK Modulation

Frequency Range	Test distance	Raw Data		BW Corr Factor	RX Mixer Corr Factor	RX Ant Corr Factor	Distance Corr Factor	Field Strength (Calculated)	Convert Field Strength to EIRP	Limit	Margin
		Freq	Level								
GHz	Meter	GHz	dBuV/m	dB	dB	dB	dB	dBuV/m	dBm	dBm	dB
0.03 -1	3	990.3	31.20	8.75	0	0.00	4.77	27.22	-79.78	-13	-66.78
1 - 18	1	13.75	24.20	8.75	0	40.40	0.00	55.85	-51.15	-13	-38.15
18 - 40	1	39.38	42.70	8.75	0	46.60	0.00	80.55	-26.45	-13	-13.45
40 - 50	1	43.425	21.00	8.75	23.2	39.66	0.00	75.11	-31.89	-13	-18.89
50 - 75	1	50	12.10	8.75	36.3	40.89	0.00	80.54	-26.46	-13	-13.46
75 - 110	0.1	87.25	30.20	8.75	42.1	45.63	-20.00	89.18	-17.82	-13	-4.82
110 - 150	0.1	126.2	5.40	8.75	60.8	49.93	-20.00	87.38	-19.62	-13	-6.62

TMA Antenna_Tuned Freq = 30 GHz_8PSK Modulation

Frequency Range	Test distance	Raw Data		BW Corr Factor	RX Mixer Corr Factor	RX Ant Corr Factor	Distance Corr Factor	Field Strength (Calculated)	Convert Field Strength to EIRP	Limit	Margin
		Freq	Level								
GHz	Meter	GHz	dBuV/m	dB	dB	dB	dB	dBuV/m	dBm	dBm	dB
0.03 -1	3	966.1	33.30	8.75	0	0.00	4.77	29.32	-77.68	-13	-64.68
1 - 18	1	14.062	23.80	8.75	0	41.30	0.00	56.35	-50.65	-13	-37.65
18 - 40	1	39.3	41.30	8.75	0	46.30	0.00	78.85	-28.15	-13	-15.15
40 - 50	1	40.05	21.30	8.75	24.1	38.86	0.00	75.51	-31.49	-13	-18.49
50 - 75	1	50.1	12.30	8.75	36.1	41.11	0.00	80.76	-26.24	-13	-13.24
75 - 110	0.1	88.738	27.60	8.75	41.8	45.87	-20.00	86.52	-20.48	-13	-7.48
110 - 150	0.1	126.2	6.00	8.75	60.8	49.93	-20.00	87.98	-19.02	-13	-6.02



Emission Limitations (radiated) Test Data

50 ohm Load_Tuned Freq = 29 GHz_QPSK Modulation

Frequency Range	Test distance	Raw Data		BW Corr Factor	RX Mixer Corr Factor	RX Ant Corr Factor	Distance Corr Factor	Field Strength (Calculated)	Convert Field Strength to EIRP	Limit	Margin
		Freq	Level								
GHz	Meter	GHz	dBuV/m	dB	dB	dB	dB	dBuV/m	dBm	dBm	dB
0.03 -1	3	536.8	38.30	8.75	0	0.00	4.77	34.32	-72.68	-13	-59.68
1 - 18	1	13.75	25.50	8.75	0	40.40	0.00	57.15	-49.85	-13	-36.85
18 - 40	1	39.74	37.70	8.75	0	46.90	0.00	75.85	-31.15	-13	-18.15
40 - 50	1	43.875	-0.80	8.75	23	39.75	0.00	53.20	-53.80	-13	-40.80
50 - 75	1	60.625	-0.40	8.75	34.3	42.66	0.00	67.81	-39.19	-13	-26.19
75 - 110	0.1	103.175	0.80	8.75	43.1	47.38	-20.00	62.53	-44.47	-13	-31.47
110 - 150	0.1	110	13.10	8.75	51.4	48.74	-20.00	84.49	-22.51	-13	-9.51

50 ohm Load_Tuned Freq = 29.5 GHz_QPSK Modulation

Frequency Range	Test distance	Raw Data		BW Corr Factor	RX Mixer Corr Factor	RX Ant Corr Factor	Distance Corr Factor	Field Strength (Calculated)	Convert Field Strength to EIRP	Limit	Margin
		Freq	Level								
GHz	Meter	GHz	dBuV/m	dB	dB	dB	dB	dBuV/m	dBm	dBm	dB
0.03 -1	3	180.4	32.90	8.75	0	0.00	4.77	28.92	-78.08	-13	-65.08
1 - 18	1	13.863	24.30	8.75	0	40.70	0.00	56.25	-50.75	-13	-37.75
18 - 40	1	39.63	38.70	8.75	0	46.90	0.00	76.85	-30.15	-13	-17.15
40 - 50	1	45.825	0.70	8.75	22.4	40.13	0.00	54.48	-52.52	-13	-39.52
50 - 75	1	50.563	0.10	8.75	35.5	40.99	0.00	67.84	-39.16	-13	-26.16
75 - 110	0.1	87.163	-2.00	8.75	42.1	45.62	-20.00	56.97	-50.03	-13	-37.03
110 - 150	0.1	110	12.80	8.75	51.4	48.74	-20.00	84.19	-22.81	-13	-9.81

50 ohm Load_Tuned Freq = 30 GHz_QPSK Modulation

Frequency Range	Test distance	Raw Data		BW Corr Factor	RX Mixer Corr Factor	RX Ant Corr Factor	Distance Corr Factor	Field Strength (Calculated)	Convert Field Strength to EIRP	Limit	Margin
		Freq	Level								
GHz	Meter	GHz	dBuV/m	dB	dB	dB	dB	dBuV/m	dBm	dBm	dB
0.03 -1	3	134.3	34.10	8.75	0	0.00	4.77	30.12	-76.88	-13	-63.88
1 - 18	1	13.693	24.30	8.75	0	40.30	0.00	55.85	-51.15	-13	-38.15
18 - 40	1	39.67	37.50	8.75	0	46.90	0.00	75.65	-31.35	-13	-18.35
40 - 50	1	42.075	3.50	8.75	22.3	39.29	0.00	56.34	-50.66	-13	-37.66
50 - 75	1	60	1.90	8.75	34.2	42.67	0.00	70.02	-36.98	-13	-23.98
75 - 110	0.1	82.875	1.30	8.75	42.7	45.28	-20.00	60.53	-46.47	-13	-33.47
110 - 150	0.1	110.6	12.40	8.75	51.4	48.79	-20.00	83.84	-23.16	-13	-10.16



Emission Limitations (radiated) Test Data

50 ohm Load _Tuned Freq = 29 GHz_BPSK Modulation

Frequency Range	Test distance	Raw Data		BW Corr Factor	RX Mixer Corr Factor	RX Ant Corr Factor	Distance Corr Factor	Field Strength (Calculated)	Convert Field Strength to EIRP	Limit	Margin
		Freq	Level								
GHz	Meter	GHz	dBuV/m	dB	dB	dB	dB	dBuV/m	dBm	dBm	dB
0.03 -1	3	995	32.50	8.75	0.00	0.00	4.77	28.52	-78.48	-13	-65.48
1 - 18	1	13.92	24.80	8.75	0.00	41.00	0.00	57.05	-49.95	-13	-36.95
18 - 40	1	39.71	38.00	8.75	0.00	46.90	0.00	76.15	-30.85	-13	-17.85
40 - 50	1	41.15	-2.40	8.75	22.80	39.20	0.00	50.85	-56.15	-13	-43.15
50 - 75	1	56.563	-0.20	8.75	33.30	42.06	0.00	66.41	-40.59	-13	-27.59
75 - 110	0.1	82.875	0.50	8.75	42.70	45.48	-20.00	59.93	-47.07	-13	-34.07
110 - 150	0.1	110.2	12.40	8.75	51.40	48.75	-20.00	83.80	-23.20	-13	-10.20

50 ohm Load _Tuned Freq = 29.5 GHz_BPSK Modulation

Frequency Range	Test distance	Raw Data		BW Corr Factor	RX Mixer Corr Factor	RX Ant Corr Factor	Distance Corr Factor	Field Strength (Calculated)	Convert Field Strength to EIRP	Limit	Margin
		Freq	Level								
GHz	Meter	GHz	dBuV/m	dB	dB	dB	dB	dBuV/m	dBm	dBm	dB
0.03 -1	3	131.9	31.50	8.75	0.00	0.00	4.77	27.52	-79.48	-13	-66.48
1 - 18	1	13.92	24.20	8.75	0.00	41.00	0.00	56.45	-50.55	-13	-37.55
18 - 40	1	39.89	37.90	8.75	0.00	47.30	0.00	76.45	-30.55	-13	-17.55
40 - 50	1	43.325	0.30	8.75	23.00	39.64	0.00	54.19	-52.81	-13	-39.81
50 - 75	1	68.125	2.10	8.75	34.80	43.58	0.00	71.73	-35.27	-13	-22.27
75 - 110	0.1	86.463	0.70	8.75	42.00	45.55	-20.00	59.50	-47.50	-13	-34.50
110 - 150	0.1	110.2	14.10	8.75	51.40	48.75	-20.00	85.50	-21.50	-13	-8.50

50 ohm Load _Tuned Freq = 30 GHz_BPSK Modulation

Frequency Range	Test distance	Raw Data		BW Corr Factor	RX Mixer Corr Factor	RX Ant Corr Factor	Distance Corr Factor	Field Strength (Calculated)	Convert Field Strength to EIRP	Limit	Margin
		Freq	Level								
GHz	Meter	GHz	dBuV/m	dB	dB	dB	dB	dBuV/m	dBm	dBm	dB
0.03 -1	3	134.3	34.30	8.75	0.00	0.00	4.77	30.32	-76.68	-13	-63.68
1 - 18	1	13.523	24.30	8.75	0.00	40.00	0.00	55.55	-51.45	-13	-38.45
18 - 40	1	39.78	38.00	8.75	0.00	47.00	0.00	76.25	-30.75	-13	-17.75
40 - 50	1	42.075	3.00	8.75	22.30	39.29	0.00	55.84	-51.16	-13	-38.16
50 - 75	1	60	18.60	8.75	34.20	42.67	0.00	86.72	-20.28	-13	-7.28
75 - 110	0.1	102.3	0.60	8.75	42.90	47.11	-20.00	61.86	-45.14	-13	-32.14
110 - 150	0.1	110.3	12.90	8.75	51.40	48.76	-20.00	84.31	-22.69	-13	-9.69



Emission Limitations (radiated) Test Data

50 ohm Load _Tuned Freq = 29 GHz_8PSK Modulation

Frequency Range	Test distance	Raw Data		BW Corr Factor	RX Mixer Corr Factor	RX Ant Corr Factor	Distance Corr Factor	Field Strength (Calculated)	Convert Field Strength to EIRP	Limit	Margin
		Freq	Level								
GHz	Meter	GHz	dBuV/m	dB	dB	dB	dB	dBuV/m	dBm	dBm	dB
0.03 -1	3	177.9	35.70	8.75	0.00	0.00	4.77	31.72	-75.28	-13	-62.28
1 - 18	1	13.778	24.50	8.75	0.00	40.50	0.00	56.25	-50.75	-13	-37.75
18 - 40	1	39.12	39.00	8.75	0.00	46.60	0.00	76.85	-30.15	-13	-17.15
40 - 50	1	40.4	-1.60	8.75	22.80	39.04	0.00	51.49	-55.51	-13	-42.51
50 - 75	1	62.063	-0.10	8.75	33.80	42.87	0.00	67.82	-39.18	-13	-26.18
75 - 110	0.1	87.688	0.40	8.75	42.20	45.97	-20.00	60.22	-46.78	-13	-33.78
110 - 150	0.1	110	13.20	8.75	51.40	48.74	-20.00	84.49	-22.51	-13	-9.51

50 ohm Load _Tuned Freq = 29.5 GHz_8PSK Modulation

Frequency Range	Test distance	Raw Data		BW Corr Factor	RX Mixer Corr Factor	RX Ant Corr Factor	Distance Corr Factor	Field Strength (Calculated)	Convert Field Strength to EIRP	Limit	Margin
		Freq	Level								
GHz	Meter	GHz	dBuV/m	dB	dB	dB	dB	dBuV/m	dBm	dBm	dB
0.03 -1	3	134.3	34.40	8.75	0.00	0.00	4.77	30.42	-76.58	-13	-63.58
1 - 18	1	13.722	23.90	8.75	0.00	40.30	0.00	55.45	-51.55	-13	-38.55
18 - 40	1	39.56	37.60	8.75	0.00	46.90	0.00	75.75	-31.25	-13	-18.25
40 - 50	1	43.675	-0.80	8.75	23.10	39.71	0.00	53.26	-53.74	-13	-40.74
50 - 75	1	65	-0.20	8.75	33.20	43.17	0.00	67.42	-39.58	-13	-26.58
75 - 110	0.1	109.738	0.30	8.75	44.50	47.62	-20.00	61.37	-45.63	-13	-32.63
110 - 150	0.1	110	13.20	8.75	51.40	48.74	-20.00	84.59	-22.41	-13	-9.41

50 ohm Load _Tuned Freq = 30 GHz_8PSK Modulation

Frequency Range	Test distance	Raw Data		BW Corr Factor	RX Mixer Corr Factor	RX Ant Corr Factor	Distance Corr Factor	Field Strength (Calculated)	Convert Field Strength to EIRP	Limit	Margin
		Freq	Level								
GHz	Meter	GHz	dBuV/m	dB	dB	dB	dB	dBuV/m	dBm	dBm	dB
0.03 -1	3	180.4	33.70	8.75	0.00	0.00	4.77	29.72	-77.28	-13	-64.28
1 - 18	1	13.778	24.90	8.75	0.00	40.50	0.00	56.65	-50.35	-13	-37.35
18 - 40	1	39.49	37.40	8.75	0.00	46.80	0.00	75.45	-31.55	-13	-18.55
40 - 50	1	42.075	2.20	8.75	22.30	39.29	0.00	55.04	-51.96	-13	-38.96
50 - 75	1	60	1.60	8.75	34.20	42.67	0.00	69.72	-37.28	-13	-24.28
75 - 110	0.1	94.6	0.60	8.75	42.50	46.43	-20.00	61.48	-45.52	-13	-32.52
110 - 150	0.1	110	12.60	8.75	51.40	48.74	-20.00	83.99	-23.01	-13	-10.01

Necessary Bandwidth Calculations (Occupied Bandwidth)

Engineer: Greg Corbin

Test Date: 12/8/2015

The table below contains the necessary bandwidth calculations for the EUT.
 The necessary bandwidth calculations were provided by the manufacturer.

Data Rate (kbps)	Symbol Rate (ksym/s)	Modulation Type	Signal States (S)	Performance Factor (K)	Necessary Bandwidth (kHz)	FCC Designator	Authorized Bandwidth (kHz)
47000	5875	8PSK	8	0.25	7833	7M83G7W	225
20000	5000	QPSK	4	0.25	5000	5M00G1W	225
936	468	BPSK	2	0.25	468	468kG7W	225

Frequency Tolerance (Temperature Variation)

Test Engineer: Greg Corbin

Test Date: 10/29/2015

Limit: 0.001%

Test Procedure

The EUT was placed in an environmental test chamber and the temperature was raised from -20°C to 50°C in 10°C increments. The EUT RF output was connected to the spectrum analyzer via a 20 dB coupler. At each 10°C increment the frequency was measured.

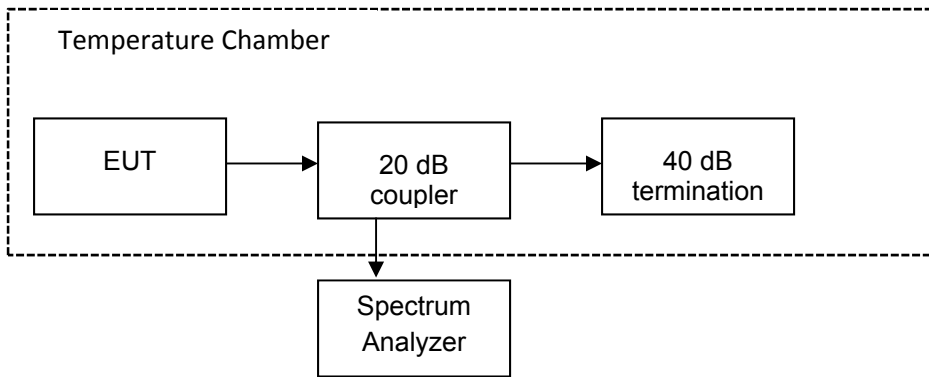

Test Plot

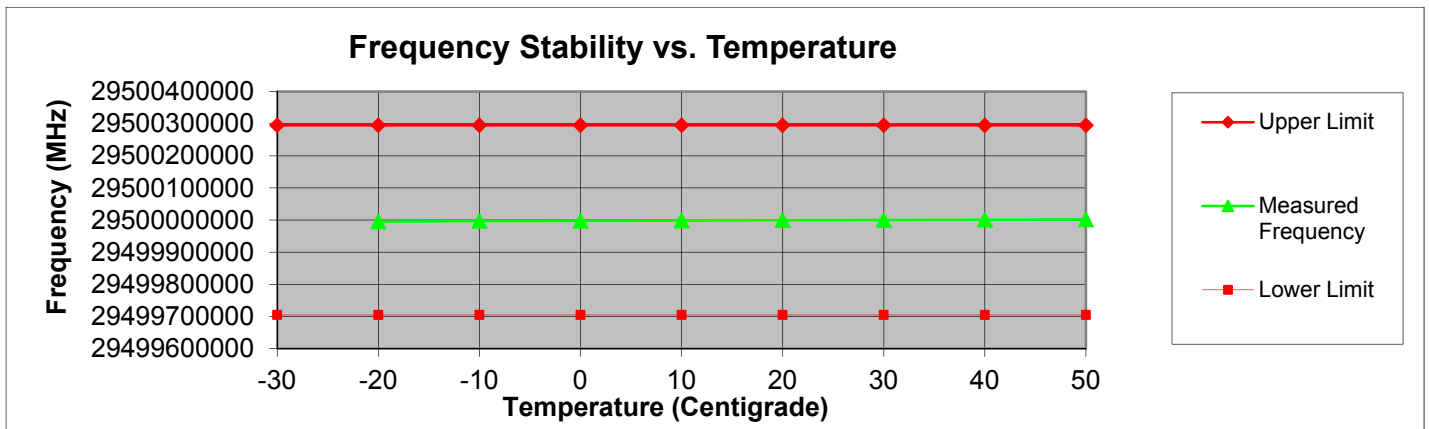

Frequency Tolerance (Voltage Variation)

Engineer: Greg Corbin

Test Date: 10/29/2015

Test Procedure

The EUT was powered by a power supply in one of the test racks provided by the manufacturer. This is where the power to the EUT was varied. The EUT RF output was connected to the spectrum analyzer via a 20 dB coupler. At 20°C, the EUT output frequency was measured at the nominal voltage and at the $\pm 15\%$ voltage levels for the EUT.

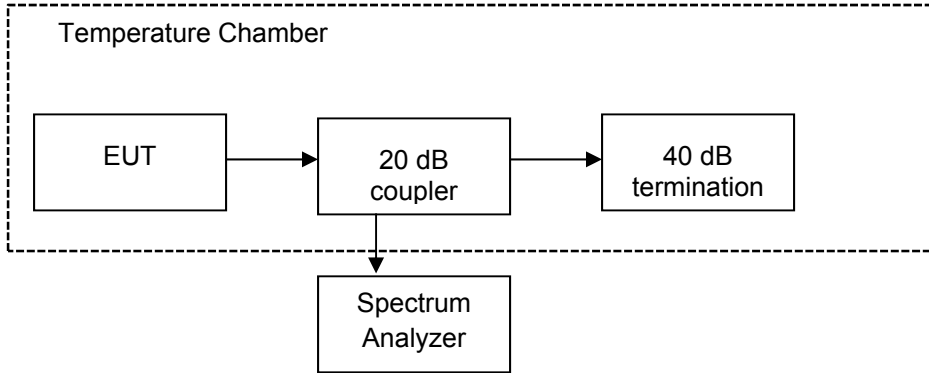

Test Plot

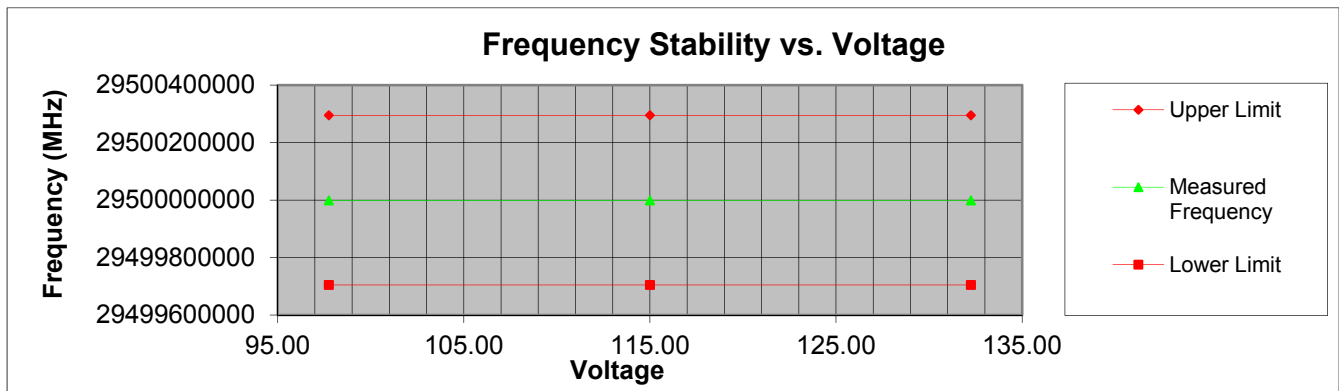

Test Equipment Utilized

Description	MFG	Model Number	CT Asset Number	Last Cal Date	Cal Due Date
Horn Antenna	EMCO	3116	i00085	1/29/15	1/29/17
Horn Antenna	EMCO	3115	i00103	1/20/15	1/20/17
Horn Antenna, Amplified	ARA	DRG-118/A	i00271	5/8/14	5/8/16
Spectrum Analyzer	Agilent	E4407B	i00331	9/18/15	9/18/16
Bi-Log Antenna	Schaffner	CBL 6111D	i00349	10/19/15	10/19/17
Harmonic Mixer	HP	11970V	00463	6/04/15	6/04/16
Harmonic Mixer	HP	11970W	00464	6/20/15	6/20/16
Harmonic Mixer	HP	11970Q	00465	6/04/15	6/04/16
Horn Antenna, standard gain	CMI	H06R	00475	NR	NR
Horn Antenna, standard gain	CMI	H010R	00476	NR	NR
Horn Antenna, standard gain	CMI	Ho15R	00477	NR	NR
Harmonic Mixer	OML	M06HWD	00480	7/27/15	7/27/16
Horn Antenna, standard gain	CMI	H022R	00484	NR	NR
Spectrum Analyzer	Agilent	E4448A (rental)	S/N:MY46180662	6/24/15	6/14/17

In addition to the above listed equipment standard RF connectors and cables were utilized in the testing of the described equipment. Prior to testing these components were tested to verify proper operation.

END OF TEST REPORT