

TABLE OF CONTENTS LIST

APPLICANT: YAESU MUSEN CO., LTD.

FCC ID: K66VXA-120

TEST REPORT:

PAGE	1.....	COVER SHEET - GENERAL INFORMATION & TECHNICAL DESCR.
PAGE	2.....	TECHNICAL DESCRIP. CONTINUED.
PAGE	3.....	RF POWER OUTPUT AND MODULATION CHARACTERISTICS
PAGE	4.....	OCCUPIED BANDWIDTH
PAGE	5.....	METHOD OF MEASURING SPURIOUS EMISSIONS AND SPURIOUS EMISSIONS AT ANTENNA TERMINALS
PAGE	6.....	RADIATED SPURIOUS EMISSIONS
PAGE	7.....	METHOD OF MEASURING RADIATED SPURIOUS EMISSIONS
PAGE	8.....	FREQUENCY STABILITY
PAGE	9.....	CERTIFICATION OF TECHNICAL DATA AND LIST OF TEST EQUIPMENT

EXHIBIT CONTAINING:

EXHIBIT	1.....	POWER OF ATTORNEY LETTER
EXHIBIT	2.....	FCC ID LABEL SAMPLE AND SKETCH OF LOCATION
EXHIBIT	3A.....	FRONT VIEW EXTERNAL PHOTO
EXHIBIT	3B.....	REAR VIEW EXTERNAL PHOTO
EXHIBIT	3C.....	SIDE VIEW EXTERNAL PHOTO
EXHIBIT	3D.....	TOP VIEW EXTERNAL PHOTO
EXHIBIT	3E.....	REAR VIEW W/O BATTERY COVER PHOTO
EXHIBIT	3F.....	INTERNAL COMPONENT SIDE PHOTO
EXHIBIT	3G.....	INTERNAL SOLDER SIDE PHOTO
EXHIBIT	4.....	BLOCK DIAGRAM
EXHIBIT	5.....	SCHEMATIC - MAIN UNIT
EXHIBIT	6.....	SCHEMATIC - VR
EXHIBIT	7.....	SCHEMATIC - SW UNIT
EXHIBIT	8A-B.....	PART LIST
EXHIBIT	9.....	USER'S MANUAL
EXHIBIT	10A-E.....	CIRCUIT DESCRIPTION
EXHIBIT	11A-C.....	ALIGNMENT PROCEDURE
EXHIBIT	12.....	AUDIO FREQUENCY RESPONSE PLOT
EXHIBIT	13A.....	MODULATION LIMITING PLOT - 300 Hz
EXHIBIT	13B.....	MODULATION LIMITING PLOT - 1000 Hz
EXHIBIT	13C.....	MODULATION LIMITING PLOT - 3000 Hz
EXHIBIT	14.....	OCCUPIED BANDWIDTH CW PLOT
EXHIBIT	15.....	OCCUPIED BANDWIDTH PLOT

APPLICANT: YAESU MUSEN CO., LTD.

FCC ID: K66VXA-120

DATE: DECEMBER 6, 1999

REPORT #: T:\CUS\Y\YAE\YAE471A9\YAE471A9.RPT

TABLE OF CONTENTS

GENERAL INFORMATION REQUIRED
FOR TYPE ACCEPTANCE

- 2.983 (a,b,c) YAESU MUSEN CO., LTD. will sell their FCC ID: K66VXA-120 in quantity, for use under FCC RULES PART 87, AERONAUTICAL GROUND STATION. This UUT has an antenna connector.
- 2.983 (d) TECHNICAL DESCRIPTION
- (2) Type of Emission: 3K20A3E
- ALLOWED AUTHORIZED BANDWIDTH = 25KHz.
- Frequency Range: Part 87: 118-137MHz,
TEST FREQ = 127.000MHz.
- (3) Power Range and Controls: The output of this UNIT is NOT adjustable.
- (4) Maximum Output Power Rating: 1.0 Watt average power into ohms resistive load.
- (5) DC Voltages and Current into Final Amplifier:
- FINAL AMPLIFIER ONLY
7.2VDC
Vce = 7.20Volts
Ice = 0.90A.
- 2.983(d) (6) Function of each electron tube or semiconductor device or other active circuit device:
- See Exhibit 8A-8B.
- 2.983(d) (7) Complete Circuit Diagrams: The circuit diagram is included as Exhibit #: 5-7. The block diagram is also included as Exhibit #: 4.
- (8) Instruction book. The instruction manual is included as Exhibit # 9.
- (9) Tune-up procedure. The tune-up procedure is given as Exhibit # 11A-11C
- 2.983(d)(10) Description of all circuitry and devices provided for determining and stabilizing frequency.

The frequency Stability of the K66VXA-120 is described in Exhibit # 10A-10E.

APPLICANT: YAESU MUSEN CO., LTD.
FCC ID: K66VXA-120
DATE: DECEMBER 6, 1999
REPORT #: T:\CUS\Y\YAE\YAE471A9\YAE471A9.RPT
PAGE #: 1

2.983(d) (11) Description of any circuits or devices employed for suppression of spurious radiation, for limiting modulation, and for limiting power.

The control circuits are described in Exhibit # 10A-10E.

2.983(d) (11) Description of any circuits or devices employed for suppression of spurious radiation, for limiting modulation, and for limiting power.

Limiting Modulation:

The transmitter audio circuitry is contained in the audio processing board and is controlled by that assembly dependent upon which combination of modulation.

2.983(d) Limiting Power:

There is no provision for limiting power, the design limits the power to 10Watts. There is NO provision for reducing the power.

(12) Digital modulation. This unit does not use digital modulation.

2.983(e) The data required by 2.985 through 2.997 is submitted below.

APPLICANT: YAESU MUSEN CO., LTD.

FCC ID: K66VXA-120

DATE: DECEMBER 6, 1999

REPORT #: T:\CUS\Y\YAE\YAE471A9\YAE471A9.RPT

PAGE #: 2

2.985(a) RF_power_output.

RF power is measured by connecting a 50 ohm, resistive watt meter to the RF output connector. With a nominal voltage of 7.2VDC and the transmitter properly adjusted the RF output measures:

INPUT POWER: FOR 7.2V OPERATION
 $(7.2)(0.9) = 6.48\text{Watts}$

OUTPUT POWER: FOR 7.2V OPERATION
1.0WATTS

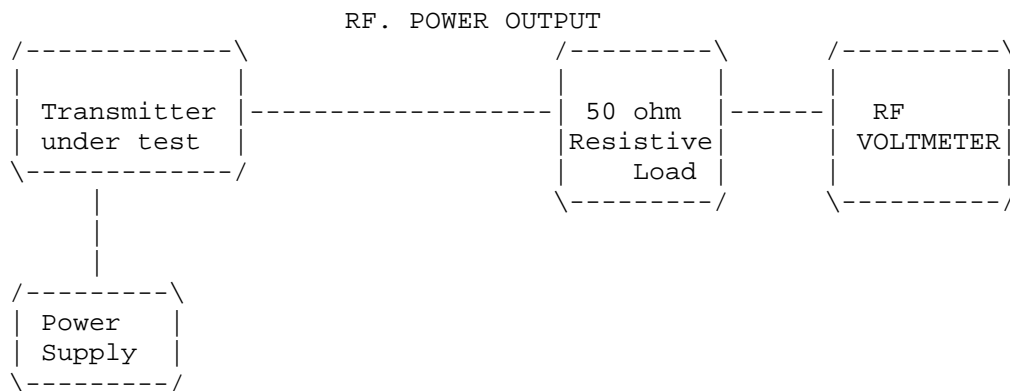

2.987(a)(b) Modulation_characteristics:

AUDIO FREQUENCY RESPONSE

The audio frequency response was measured in accordance with TIA/EIA Specification 603 Paragraph 2.2.6.

87.141 AUDIO LOW PASS FILTER

The audio low pass filter is not required in this unit.

2.987(b) Audio input versus modulation

See Exhibit # 13A-13C

2.989(c) Occupied bandwidth:

Data in the plots shows that frequencies removed from the assigned frequency by more than 50%(12.5KHz) up to and including 100% percent of the authorized bandwidth the attenuation must be at least 25dB. When the frequency is removed from the assigned frequency by more than 100% up to and including 250% of the authorized bandwidth the attenuation must be at least 35dB. When the frequency is removed from the assigned frequency by more than 250% of the authorized bandwidth the attenuation must be at least $43 + \log pY$ dB. The plots show the transmitter modulated with 2500 Hz(the highest modulation frequency), adjusted for 50% modulation plus 16dB. The spectrum analyzer was set with the unmodulated carrier at the top of the screen. The test procedure diagram and occupied bandwidth plots follow.

Microphone transmitter.

Test procedure diagram

OCCUPIED BANDWIDTH MEASUREMENT

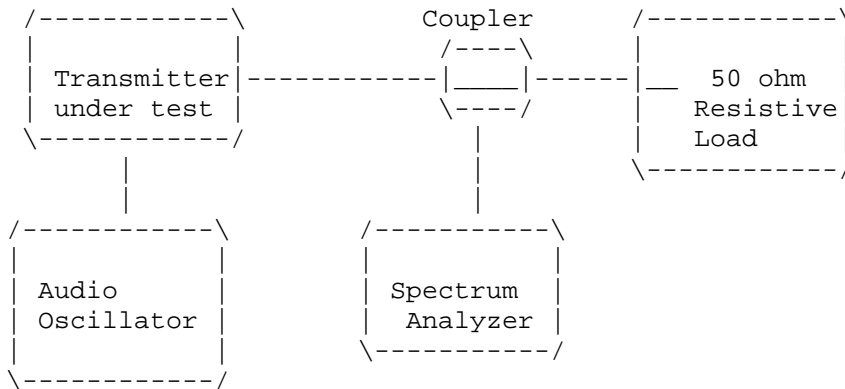

2.991 Spurious emissions at antenna terminals(conducted):

Data on the following page shows the level of conducted spurious responses. The carrier was modulated 90% using a 2500Hz tone. The spectrum was scanned from 30 to at least the 10th harmonic of the fundamental.

Method of Measuring Conducted Spurious Emissions

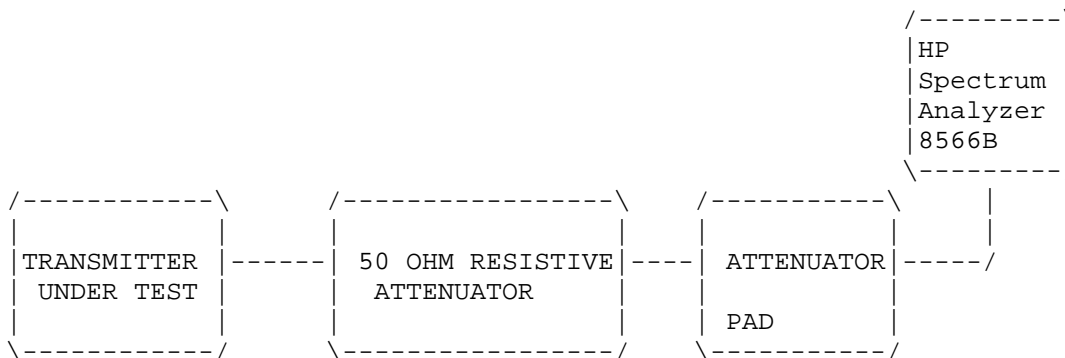

NAME OF TEST: SPURIOUS EMISSIONS AT ANTENNA TERMINALS

REQUIREMENTS: Emissions must be 43 +10log(Po) dB below the mean power output of the transmitter.

$$43 + 10 \log(35) = 45.5\text{dB}$$

EMISSION FREQUENCY MHz	dB BELOW CARRIER
118.00	00.00
236.00	-62.40
354.00	-59.70
472.00	-84.80
590.00	-87.10
708.00	-98.60
826.00	-99.30
944.00	-102.60
1062.00	-102.70
1180.00	-105.70

METHOD OF MEASUREMENT: The procedure used was TIA/EIA 603. The spectrum was scanned from 30 to at least the tenth harmonic of the fundamental using a HP model 8566B spectrum analyzer. The measurements were made using the shielded room located at TIMCO ENGINEERING INC. 849 N.W. STATE ROAD 45, NEWBERRY, FLORIDA 32669.

APPLICANT: YAESU MUSEN CO., LTD.
 FCC ID: K66VXA-120
 DATE: DECEMBER 6, 1999
 REPORT #: T:\CUS\Y\YAE\YAE471A9\YAE471A9.RPT
 PAGE #: 5

2.993(a)(b) Field strength of spurious emissions:

The tabulated Data shows the results of the radiated field strength emissions test. The spectrum was scanned from 30 to at least the 10th harmonic of the fundamental. This test was conducted per TIA/EIA 603.

NAME OF TEST: RADIATED SPURIOUS EMISSIONS

REQUIREMENTS: Emissions must be 43 +10log(Po) dB below the mean power output of the transmitter.

$$43 + 10 \log(10.0) = 43 \text{ dB}$$

EMISSION FREQUENCY MHz	RELATIVE ATTENUATION db
118.03	0.0
236.06	-64.71
346.00	62.05
472.10	-64.62
590.10	-69.16
708.10	-67.31
826.20	-68.57
944.20	-71.73
1180.30	-78.42

METHOD OF MEASUREMENT: The procedure used was Tested in accordance with TIA/EIA 603 paragraph 2.2.12. The spectrum was scanned from 30.000 to at least the tenth harmonic of the fundamental using a HP model 8566B spectrum analyzer, an Eaton model 94455-1 Biconical Antenna, a ElectroMetrics antennas models TDA, TDS-25-1, TDS-25-2. Measurements were made at the open field test site of TIMCO ENGINEERING INC. located at 6051 N.W. 19th Lane, Gainesville, Florida 32605.

APPLICANT: YAESU MUSEN CO., LTD.
FCC ID: K66VXA-120
DATE: DECEMBER 6, 1999
REPORT #: T:\CUS\Y\YAE\YAE471A9\YAE471A9.RPT
PAGE #: 6

Method of Measuring Radiated Spurious Emissions

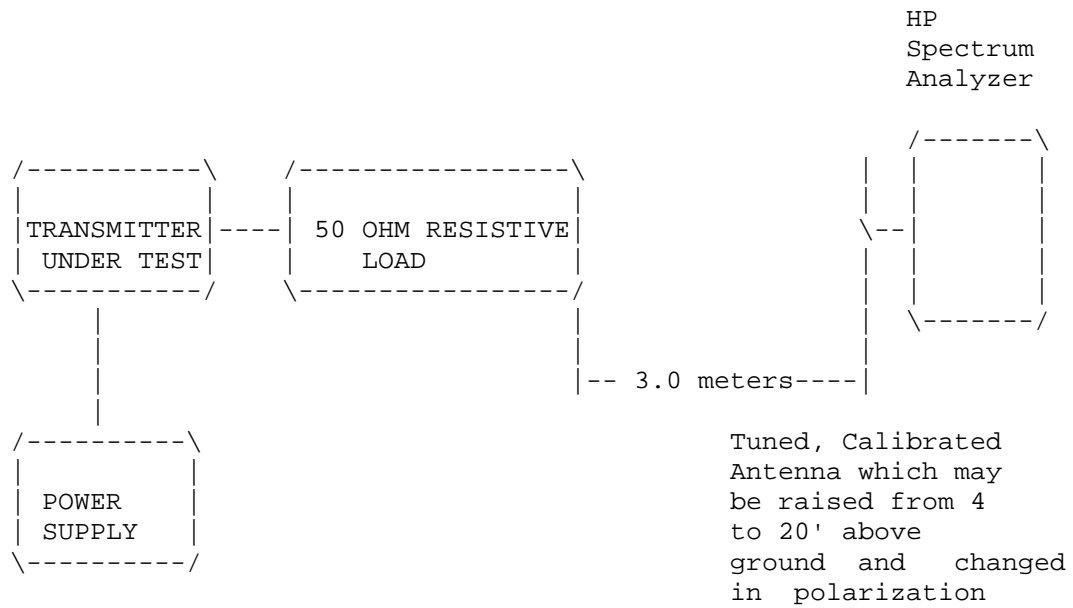

Equipment placed 4' above ground
on a rotatable platform.

APPLICANT: YAESU MUSEN CO., LTD.
FCC ID: K66VXA-120
DATE: DECEMBER 6, 1999
REPORT #: T:\CUS\Y\YAE\YAE471A9\YAE471A9.RPT
PAGE #: 7

2.995(a)(b)(d) Frequency stability:
87.133

Temperature and voltage tests were performed to verify that the frequency remains within the .0020%, (20 ppm) (87.133) specification limit.

The test was conducted as follows: The transmitter was placed in the temperature chamber at 25 degrees C and allowed to stabilize for one hour. The transmitter was keyed ON for one minute during which four frequency readings were recorded at 15 second intervals. The worse case number was taken for temperature plotting. The assigned channel frequency was considered to be the reference frequency. The temperature was then reduced to -30 degrees C after which the transmitter was again allowed to stabilize for one hour. The transmitter was keyed ON for one minute, and again frequency readings were noted at 15 second intervals. The worst case number was recorded for temperature plotting. This procedure was repeated in 10 degree increments up to + 50 degrees C.

MEASUREMENT DATA:

Assigned Frequency (Ref. Frequency): 118.02505 MHz

TEMPERATURE_C	FREQUENCY_MHz	PPM
REFERENCE	118.025 050	00.00
-30	118.024 670	-00.32
-20	118.025 230	+00.15
-10	118.025 520	+00.40
0	118.025 580	+00.45
+10	118.025 450	+00.34
+20	118.025 240	+00.16
+30	118.024 900	-00.13
+40	118.024 630	-00.36
+50	118.024 450	-00.51

25c -15% Supply Voltage	6.12 VDC	118.025 050	+ 0.00
25c +15% Supply Voltage	8.28 VDC	118.025 050	+ 0.00
+Battery End-point -	7.2 VDC	118.025 350	+ 0.25

RESULTS OF MEASUREMENTS: The maximum frequency variation over the temperature range was +00.45 to -0.51 ppm. The maximum frequency variation over the voltage range was +0.15 ppm.

APPLICANT: YAESU MUSEN CO., LTD.
FCC ID: K66VXA-120
DATE: DECEMBER 6, 1999
REPORT #: T:\CUS\Y\YAE\YAE471A9\YAE471A9.RPT
PAGE #: 8

- 2.983(f) Photo or Drawing of Label:
See 2.
- 2.983(g) Photos of Equipment:
See 3A-3G.
- 2.997 Frequency Spectrum Investigated The Spectrum investigated from 0.400 to the 10th harmonic of the fundamental.
- 2.999 Measurement Procedures for Type Acceptance:

Measurement techniques have been in accordance with EIA specifications and the FCC requirements.
- 2.909 Certification of Technical Data by Engineers

We, the undersigned, certify that the enclosed measurements and enclosed data are true and correct.

S.S. Sanders
Engineer

TEST EQUIPMENT LIST

1. Spectrum Analyzer: Hewlett Packard 8566B - Opt 462, w/ preselector 85685A, & Quasi-Peak Adapter HP 85650A, & HP 8449B - OPT H02 Cal. 10/17/99
2. Signal Generator, Hewlett Packard 8640B, cal. 9/23/99
3. Signal Generator, HP 8614A Serial No.2015A07428 cal. 5/27/99
4. EMCO Model No. 6512 Passive Loop 9KHz to 30MHz
5. Eaton Biconnical Antenna Model 94455-1
20-200 MHz Serial No. 0997 Cal. 9/30/99
6. Electro-Metric Log-Periodic Model No. EM-6950 Ser#632 9/18/99
7. Electro-Metric Dipole Kit, 20-1000 MHz, Model TDA-30 10/31/98
8. Electro-Metric Horn 1-18 GHz, Model RGA-180, Cal. 4/27/99
9. Systron Donner Horn 18-26.3GHz Model DBE-520-20 7/14/99
10. Systron Donner Horn 26.5-40.2GHz Model DBD-520-20 7/14/99
11. ATM Horn 40-60GHz Part #19-443-6R 9/15/99
12. Electro-Metric Antennas Model TDA-30/1-4, Cal. 10/15/98
13. Electro-Metric Line Impedance Stabilization Network Model No. FCC-25/2, Serial No. 2512; 450KHz-100MHz 50uH. Cal.11/18/99
14. Electro-Metric Line Impedance Stabilization Network Model No. EM-7820, Serial No. 2682; 10KHz-30MHz 50uH. Cal. 11/19/98
15. Special low loss cable was used above 1 GHz
16. Tenney Temperature Chamber
17. AC Voltmeter, HP 400FL, Serial No 2213A14499. Cal. 9/21/99
18. Digital Multimeter, Fluke 8010A/12A, Serial No. 4810047.
Cal 9/21/99
19. Digital Multimeter, Fluke 77, Serial No. 43850817. Cal 9/21/99
20. Oscilloscope, Tektronix 2230, Serial No. 300572. Cal 9/23/99
21. Frequency Counter, HP 5385A, Serial No. 3242A07460. Cal 10/6/99