



**M. Flom Associates, Inc. - Global Compliance Center**  
3356 North San Marcos Place, Suite 107, Chandler, Arizona 85224-1571  
www.goodnet.com/~mflom, (602) 926-3100, FAX: 926-3598

---

Sub-part  
2.983 (f):

EQUIPMENT IDENTIFICATION

FCC ID: K66VX-400V-2

NAMEPLATE DRAWING

ATTACHED, EXHIBIT 1.

LOCATION

AS PER LABEL DRAWING(S)

DATE OF REPORT

June 29, 1998

SUPERVISED BY:  
MF:glk

  
MORTON FLOM, P. Eng.

THE APPLICANT HAS BEEN CAUTIONED AS TO THE FOLLOWING:

15.21 INFORMATION TO USER.

The users manual or instruction manual for an intentional radiator shall caution the user that changes or modifications not expressly approved by the party responsible for compliance could void the user's authority to operate the equipment.

15.27(a) SPECIAL ACCESSORIES.

Equipment marketed to a consumer must be capable of complying with the necessary regulations in the configuration in which the equipment is marketed. Where special accessories, such as shielded cables and/or special connectors are required to enable an unintentional or intentional radiator to comply with the emission limits in this part, the equipment must be marketed with, i.e. shipped and sold with, those special accessories. However, in lieu of shipping or packaging the special accessories with the unintentional or intentional radiator, the responsible party may employ other methods of ensuring that the special accessories are provided to the consumer, without additional charge.

Information detailing any alternative method used to supply the special accessories for a grant of equipment authorization or retained in the verification records, as appropriate. The party responsible for the equipment, as detailed in § 2.909 of this chapter, shall ensure that these special accessories are provided with the equipment. The instruction manual for such devices shall include appropriate instructions on the first page of text concerned with the installation of the device that these special accessories must be used with the device. It is the responsibility of the user to use the needed special accessories supplied with the equipment.

TABLE OF CONTENTS

K66VX-400V-2

<u>RULE</u>	<u>DESCRIPTION</u>	<u>PAGE</u>
2.983	List of General Information Required	2
2.985(a)	Carrier Output Power	6
2.991	Unwanted Emissions (Transmitter Conducted)	8
2.993(a)	Field Strength of Spurious Radiation	11
2.989(c)	Occupied Bandwidth	14
90.214	Transient Frequency Behavior	16
2.987(a)	Audio Low Pass Filter (Voice Input)	19
2.987(a)	Audio Frequency Response	22
2.987(b)	Modulation Limiting	24
2.995(a)	Frequency Stability (Temperature Variation)	26
2.995(d)	Frequency Stability (Voltage Variation)	29
2.202(g)	Necessary Bandwidth and Emission Bandwidth	30

LIST OF GENERAL INFORMATION REQUIRED FOR TYPE ACCEPTANCE

IN ACCORDANCE WITH FCC RULES AND REGULATIONS,  
VOLUME II, PART 2 AND TO

22, 74, 90

Sub-part

2.983(a): NAME AND ADDRESS OF APPLICANT:

Yaesu Musen Co., Ltd.  
20-2, Shimomaruko 1-chome, Ota-ku  
Tokyo Japan 146

VENDOR:

Yaesu U.S.A.  
17210 Edwards Rd.  
Cerritos, CA 90703

2.983(b): FCC ID: K66VX-400V-2

MODEL NO: VERTEX VX-400V, TYPE A

2.983(c): QUANTITY PRODUCTION PLANNED.

2.983(d): TECHNICAL DESCRIPTION: SEE ATTACHED EXHIBITS

(1): TYPE OF EMISSION: 16K0F3E, 11K0F3E

(2): FREQUENCY RANGE, MHz: 134 to 160

(3): POWER RATING, Watts: 1, 5  
SWITCHABLE \_\_\_ ADJUSTABLE x N/A \_\_\_

(4): MAXIMUM POWER RATING, Watts: 300

2.983(d)

(5): VOLTAGES & CURRENTS IN ALL ELEMENTS IN FINAL R. F. STAGE, INCLUDING FINAL TRANSISTOR OR SOLID STATE DEVICE:

COLLECTOR CURRENT, A = per manual  
COLLECTOR VOLTAGE, Vdc = per manual  
SUPPLY VOLTAGE, Vdc = 7.2

(6): FUNCTION OF ACTIVE CIRCUIT DEVICES:

PLEASE SEE ATTACHED EXHIBITS

(7): CIRCUIT DIAGRAM:

PLEASE SEE ATTACHED EXHIBITS

(8): MANUAL:

PLEASE SEE ATTACHED EXHIBITS

(9): TUNE-UP PROCEDURE:

PLEASE SEE ATTACHED EXHIBITS

(10): DESCRIPTION OF CIRCUITRY & DEVICES PROVIDED FOR DETERMINING AND STABILIZING FREQUENCY:

PLEASE SEE ATTACHED EXHIBITS

(11): DESCRIPTION OF CIRCUITS OR DEVICES EMPLOYED FOR

- (a) SUPPRESSION OF SPURIOUS RADIATION,
- (b) LIMITING MODULATION,
- (c) LIMITING POWER:

PLEASE SEE ATTACHED EXHIBITS

(12): DIGITAL MODULATION DESCRIPTION:

ATTACHED EXHIBITS  
N/A

x

2.983(e): TEST AND MEASUREMENT DATA:

FOLLOWS

2.983(f): LABEL INFORMATION:

PLEASE SEE ATTACHED EXHIBITS

2.983(g): PHOTOGRAPHS:

PLEASE SEE ATTACHED EXHIBITS

Sub-part  
2.983(e):

TEST AND MEASUREMENT DATA

All tests and measurement data shown were performed in accordance with FCC Rules and Regulations, Volume II; Part 2, Sub-part J, Sections 2.981, 2.983, 2.985, 2.987, 2.989, 2.991, 2.993, 2.995, 2.997, 2.999 and the following individual Parts:

- 21 - Domestic Public Fixed Radio Services
- 22 - Public Mobile Services
- 22 Subpart H - Cellular Radiotelephone Service
- 22.901(d) - Alternative technologies and auxiliary services
- 23 - International Fixed Public Radiocommunication services
- 24 - Personal Communications Services
- 74 Subpart H - Low Power Auxiliary Stations
- 80 - Stations in the Maritime Services
- 80 Subpart E - General Technical Standards
- 80 Subpart F - Equipment Authorization for Compulsory Ships
- 80 Subpart K - Private Coast Stations and Marine Utility Stations
- 80 Subpart S - Compulsory Radiotelephone Installations for Small Passenger Boats
- 80 Subpart T - Radiotelephone Installation Required for Vessels on the Great Lakes
- 80 Subpart U - Radiotelephone Installations Required by the Bridge-to-Bridge Act
- 80 Subpart V - Emergency Position Indicating Radiobeacons (EPIRB'S)
- 80 Subpart W - Global Maritime Distress and Safety System (GMDSS)
- 80 Subpart X - Voluntary Radio Installations
- 87 - Aviation Services
- 90 - Private Land Mobile Radio Services
- 94 - Private Operational-Fixed Microwave Service
- 95 Subpart A - General Mobile Radio Service (GMRs)
- 95 Subpart C - Radio Control (R/C) Radio Service
- 95 Subpart D - Citizens Band (CB) Radio Service
- 95 Subpart E - Family Radio Service
- 95 Subpart F - Interactive Video and Data Service (IVDS)
- 101 - Fixed Microwave Services

STANDARD TEST CONDITIONS  
and  
ENGINEERING PRACTICES

Except as noted herein, the following conditions and procedures were observed during the testing:

ROOM TEMPERATURE	=	25±5°C
ROOM HUMIDITY	=	20-50%
D.C. SUPPLY VOLTAGE, Vdc	=	7.2
A.C. SUPPLY VOLTAGE, Vac	=	N/A
A.C. SUPPLY FREQUENCY, Hz	=	N/A

Prior to testing, the EUT was tuned up in accordance with the manufacturer's alignment procedures. All external gain controls were maintained at the position of maximum and/or optimum gain throughout the testing.

Measurement results, unless otherwise noted, are worst case measurements.

PAGE NO. 6. K66VX-400V-2

NAME OF TEST: Carrier Output Power (Conducted)

SPECIFICATION: FCC: 47 CFR 2.985(a)  
IC: RSS-119, Section 6.2

GUIDE: TIA/EIA-603, Paragraph 2.2.1

TEST CONDITIONS: Standard Temperature and Humidity (S. T. & H.)

TEST EQUIPMENT: As per attached page

MEASUREMENT PROCEDURE

1. The EUT was connected to a resistive coaxial attenuator of normal load impedance, and the unmodulated output power was measured by means of an R. F. Power Meter.
2. Measurement accuracy is  $\pm 3\%$ .

MEASUREMENT RESULTS

<u>NOMINAL, MHz</u>	<u>R.F. POWER OUTPUT, WATTS</u>	
147.025	1	5
135.025	1	5
159.975	1	5

SUPERVISED BY:

*M. J. Flom P. Eng.*  
MORTON FLOM, P. Eng.



TRANSMITTER POWER CONDUCTED MEASUREMENTS

TEST 1: R. F. POWER OUTPUT  
 TEST 2: FREQUENCY STABILITY

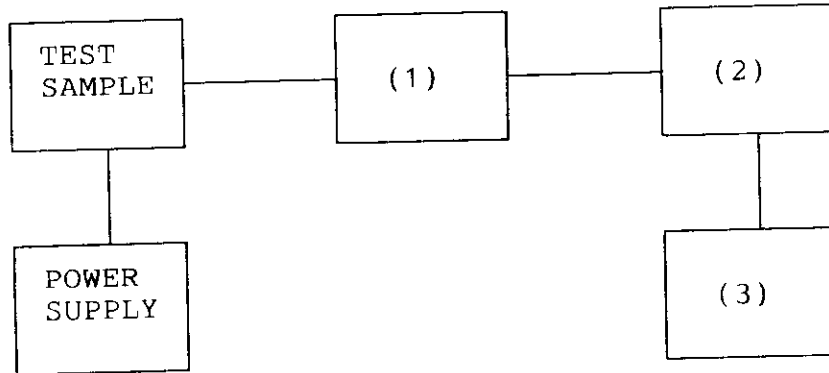

(1) COAXIAL ATTENUATOR

NARDA 766-10	---
SIERRA 661A-30	<u>x</u>
BIRD 8329 (30 dB)	---
_____	---

(2) POWER METERS

HP 435A	---
HP 436A	<u>x</u>
HP 8901A POWER MODE	<u>x</u>
_____	---

(3) FREQUENCY COUNTER

HP 5383A	---
HP 5334B	<u>x</u>
HP 8901A FREQUENCY MODE	<u>x</u>
_____	---

PAGE NO.

8.

K66VX-400V-2

NAME OF TEST:

Unwanted Emissions (Transmitter Conducted)

SPECIFICATION:

FCC: 47 CFR 2.991  
IC: RSS-119, Section 6.3

GUIDE:

TIA/EIA-603, Paragraph 2.2.13

TEST CONDITIONS:

S. T. & H.

TEST EQUIPMENT:

As per attached page

MEASUREMENT PROCEDURE

1. The emissions were measured for the worst case as follows:
  - (a): within a band of frequencies defined by the carrier frequency plus and minus one channel.
  - (b): from the lowest frequency generated in the EUT and to at least the 10th harmonic of the carrier frequency, or 40 GHz, whichever is lower.
2. The magnitude of spurious emissions which are attenuated more than 20 dB below the permissible value need not be specified.
3. MEASUREMENT RESULTS: ATTACHED FOR WORST CASE

FREQUENCY OF CARRIER, MHz	= 147.025, 135.025, 159.975
SPECTRUM SEARCHED, GHz	= 0 to $10 \times F_C$
MAXIMUM RESPONSE, Hz	= 2510
ALL OTHER EMISSIONS	= $\geq 20$ dB BELOW LIMIT
LIMIT, dBc: $-(43 + 10 \text{ LOG } P_0)$	= -43 (1 Watt) -50 (5 Watts)

SUPERVISED BY:

  
MORTON FLOM, P. Eng.

TRANSMITTER SPURIOUS EMISSION

TEST A. OCCUPIED BANDWIDTH (IN-BAND SPURIOUS)  
 TEST B. OUT-OF-BAND SPURIOUS

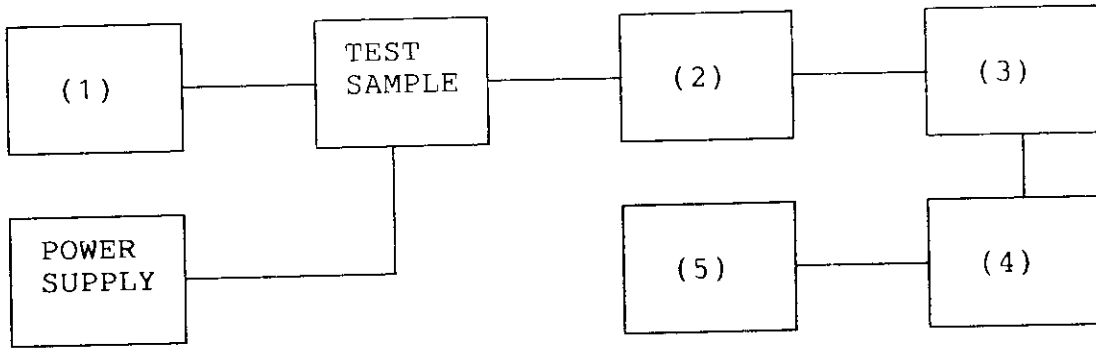

- |     |  |  |
|-----|--|--|
| (1) | <u>AUDIO OSCILLATOR/GENERATOR</u><br>HP 204D<br>HP 8903A<br>HP 3312A                     | _____<br>_____<br><u>  x  </u><br><u>  x  </u> |
| (2) | <u>COAXIAL ATTENUATOR</u><br>NARDA 766-10<br>SIERRA 661A-30<br>BIRD 8329 (30 dB)         | _____<br>_____<br><u>  x  </u><br><u>  x  </u> |
| (3) | <u>FILTERS; NOTCH, HP, LP, BP</u><br>CIRQTEL FHT<br>EAGLE TNF-1<br>PHELPS DODGE PD-495-8 | _____<br>_____<br><u>  x  </u><br>_____        |
| (4) | <u>SPECTRUM ANALYZER</u><br>HP 8566B<br>HP 8563E   | _____<br><u>  x  </u><br>_____                 |
| (5) | <u>SCOPE</u><br>HP 1741A<br>HP 181T<br>TEK 935<br>HP 54502A                              | _____<br>_____<br>_____<br>_____               |

PAGE NO.

10.1.

K66VX-400V-2

G860002

TRANSMITTER SPURIOUS EMISSIONS (CONDUCTED)

POWER: LOW

---

FREQUENCY TUNED, MHz	FREQUENCY EMISSION, MHz	LEVEL, dBm	LEVEL, dBc	LEVEL, $\mu$ W
147.025	294.054	-38.9	-68.9	0
147.025	441.070	-44.1	-74.1	0
147.025	588.108	-43.0	-73.0	0
147.025	735.179	-44.4	-74.4	0
147.025	881.689	-44.0	-74.0	0
147.025	1029.336	-44.2	-74.2	0
147.025	1176.557	-43.8	-73.8	0
147.025	1323.244	-44.4	-74.4	0
147.025	1470.246	-43.7	-73.7	0
147.025	1616.889	-43.6	-73.6	0
147.025	1764.677	-42.8	-72.8	0
147.025	1911.766	-43.6	-73.6	0
147.025	2058.356	-42.4	-72.4	0
147.025	2205.354	-43.6	-73.6	0

---

PAGE NO.

10.2.

K66VX-400V-2

G860001

TRANSMITTER SPURIOUS EMISSIONS (CONDUCTED)

POWER: HIGH

---

FREQUENCY TUNED, MHz	FREQUENCY EMISSION, MHz	LEVEL, dBm	LEVEL, dBc	LEVEL, $\mu$ W
147.025	294.061	-37.1	-74.0	0
147.025	441.095	-42.7	-79.6	0
147.025	588.098	-41.3	-78.2	0
147.025	735.609	-43.7	-80.6	0
147.025	882.571	-42.9	-79.8	0
147.025	1029.255	-43.7	-80.6	0
147.025	1176.089	-43.4	-80.3	0
147.025	1323.527	-42.9	-79.8	0
147.025	1470.715	-42.8	-79.7	0
147.025	1617.220	-42.5	-79.4	0
147.025	1764.009	-43.8	-80.7	0
147.025	1911.547	-43.0	-79.9	0
147.025	2057.851	-42.2	-79.1	0
147.025	2205.440	-42.0	-78.9	0

---

PAGE NO.

11.1.

K66VX-400V-2

NAME OF TEST:

Field Strength of Spurious Radiation

SPECIFICATION:

FCC: 47 CFR 2.993(a)

IC: N/A

GUIDE:

TIA/EIA-603, Section 2.2.12

TEST CONDITIONS:

S. T. & H.

TEST EQUIPMENT:

AS PER ATTACHED PAGE

MEASUREMENT PROCEDURE

1. A description of the measurement facilities was filed with the FCC and was found to be in compliance with the requirements of Section 15.38, by letter from the FCC dated March 3, 1997, FILE 31040/SIT. All pertinent changes will be reported to the Commission by up-date prior to March 2000.

2. At first, in order to locate all spurious frequencies and approximate amplitudes, and to determine proper equipment functioning, the test sample was set up at a distance of three meters from the test instrument. Valid spurious signals were determined by switching the power on and off.

3. In the field, the test sample was placed on a wooden turntable above ground at three (or thirty) meters away from the search antenna. The test sample was connected to an R.F. Wattmeter and a 50 ohm dummy load, and adjusted to its rated output.

In order to obtain the maximum response at each spurious frequency, the turntable was rotated. Also, the Search Antennas were raised and lowered vertically, and all cables were oriented. Excess power lead was coiled near the power supply.

4. A signal generator, connected with a non-radiating cable to a vertically polarized half-wave antenna (for each frequency involved) was substituted for the transmitter. The Search Antenna was raised and lowered to obtain maximum indicated.

5. The signal generator output was adjusted until a signal level indication equal to that from the transmitter was obtained.

6. Steps 4 and 5 were repeated, using a horizontally polarized half-wave antenna. The higher of the two observations was noted.

PAGE NO.

11.2.

K66VX-400V-2

NAME OF TEST:

Field Strength of Spurious Radiation

SPECIFICATION:

FCC: 47 CFR 2.993(a)

IC: N/A

MEASUREMENT PROCEDURE (CONT.)

7. Power into the half-wave antenna was calculated from the characteristic impedance of the line, and the voltage output from the signal generator.

8. The level of each spurious radiation with reference to the transmitter power in dB, was calculated from:

$$\text{SPURIOUS LEVEL, dB} = 10 \text{ LOG} \left( \frac{\text{Calculated Spurious Power}}{\text{Tx Power (Wattmeter)}} \right) \text{ [from para. 7].}$$

9. The worst case for all channels is shown.

10. Measurement summary:

FREQUENCY OF CARRIER, MHz	= 147.025, 135.025, 159.975
SPECTRUM SEARCHED, GHz	= 0 to $10 \times F_C$
ALL OTHER EMISSIONS	= $\geq 20$ dB BELOW LIMIT
LIMIT, dBc	= -50 (5 Watts) -43 (1 Watt)

11. Measurement results:

ATTACHED FOR WORST CASE

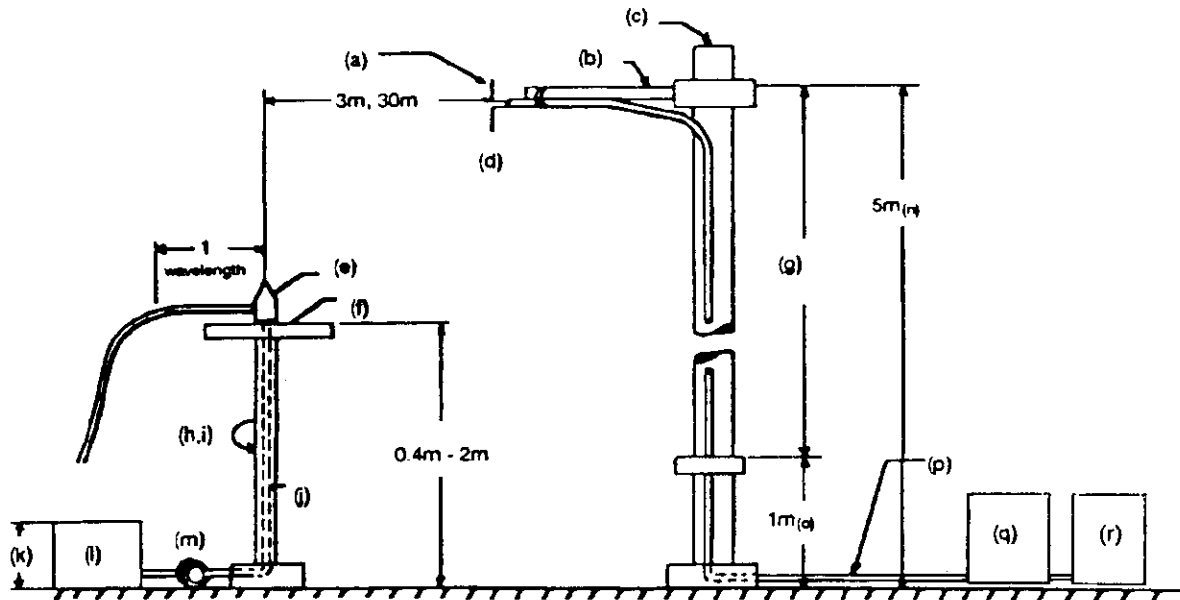
RADIATED TEST SETUP

## NOTES:

- (a) Search Antenna - Rotatable on boom.
- (b) Non-metallic boom.
- (c) Non-metallic mast.
- (d) Adjustable horizontally.
- (e) Equipment Under Test.
- (f) Turntable.
- (g) Boom adjustable in height.
- (h) External control cables routed horizontally at least one wavelength.
- (i) Rotatable.
- (j) Cables routed through hollow turntable center.
- (k) 30 cm or less.
- (l) External power source.
- (m) 10 cm diameter coil of excess cable.
- (n) 25 cm (V), 1 m-7 m (V, H).
- (o) 25 cm from bottom end of 'V', 1 m normally.
- (p) Calibrated Cable at least 10 m in length.
- (q) Amplifier (optional).
- (r) Spectrum Analyzer.



TRANSMITTER SPURIOUS EMISSIONS (RADIATED FIELD STRENGTH)

ALL OTHER EMISSIONS = ≥ 20 dB BELOW LIMIT

EMISSION, MHz/HARMONIC	SPURIOUS LEVEL BELOW	
	Lo	Hi
2nd to 10th	<-65	<-70

SUPERVISED BY:

*Morton Flom P. Eng.*  
MORTON FLOM, P. Eng.

PAGE NO.

14.

K66VX-400V-2

NAME OF TEST:

Emission Masks (Occupied Bandwidth)

SPECIFICATION:

FCC: 47 CFR 2.989(c)(1)  
IC: RSS-119, Section 6.4

GUIDE:

TIA/EIA-603, Paragraph 2.2.11

TEST CONDITIONS:

S. T. & H.

TEST EQUIPMENT:

As per previous page

MEASUREMENT PROCEDURE

1. The EUT and test equipment were set up as shown on the following page, with the Spectrum Analyzer connected.
2. For EUTs supporting audio modulation, the audio signal generator was adjusted to the frequency of maximum response and with output level set for  $\pm 2.5$  kHz deviation (or 50% modulation). With level constant, the signal level was increased 16 dB.
3. For EUTs supporting digital modulation, the digital modulation mode was operated to its maximum extent.
4. The Occupied Bandwidth was measured with the Spectrum Analyzer controls set as shown on the test results.
5. MEASUREMENT RESULTS: ATTACHED

PAGE 15.1.  
SPECTRUM ANALYZER PRESENTATION  
YAESU, VX-400V-2  
1998-JUN-24, 10:28, WED

K66VX-400V-2

POWER: LOW  
MODULATION: NONE

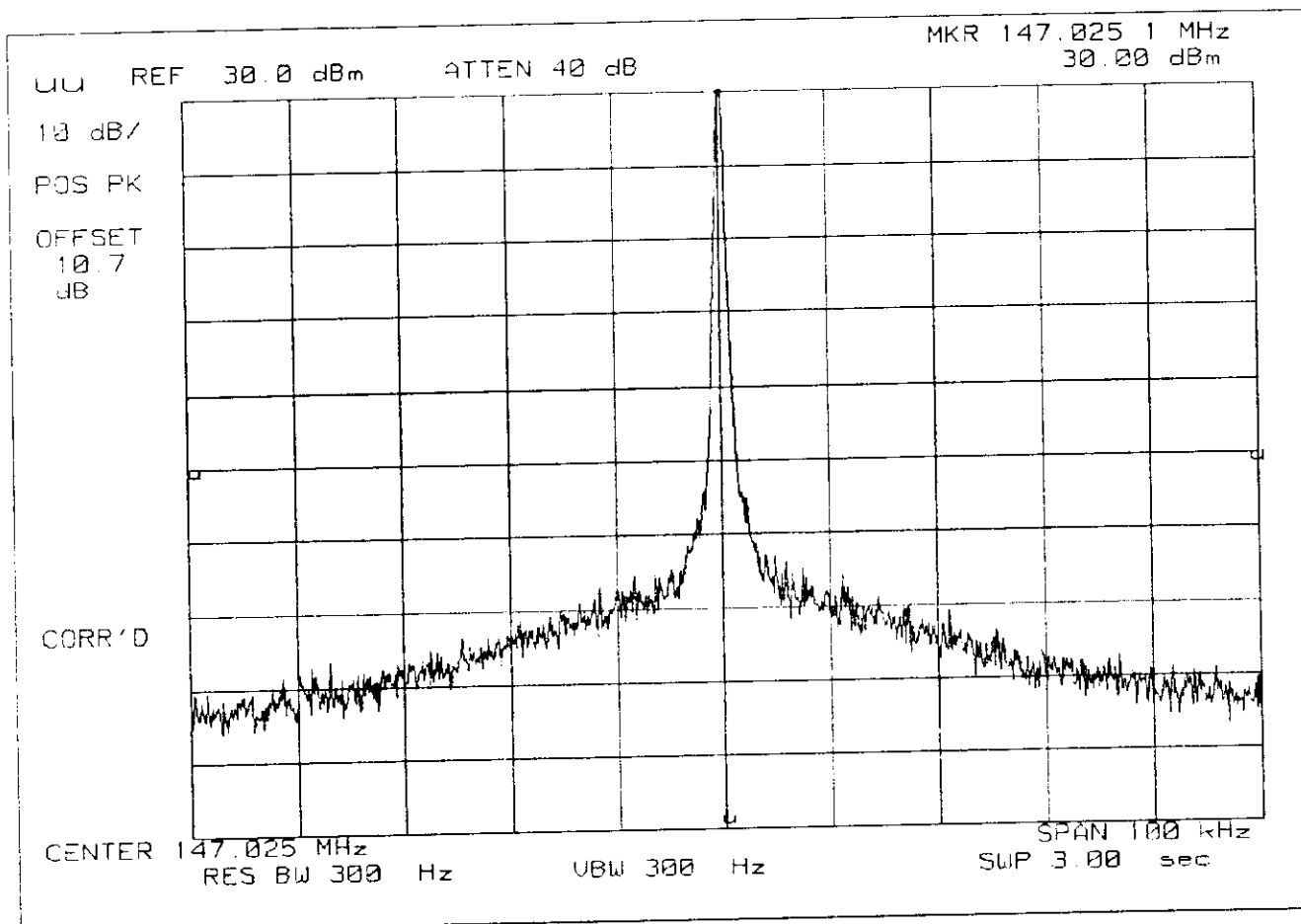

PAGE 15.2.  
SPECTRUM ANALYZER PRESENTATION  
YAESU, VX-400V-2  
1998-JUN-24, 10:53, WED

K66VX-400V-2

POWER: LOW  
MODULATION: VOICE: 2500 Hz SINE WAVE  
MASK: D, VHF/UHF 12.5kHz BW

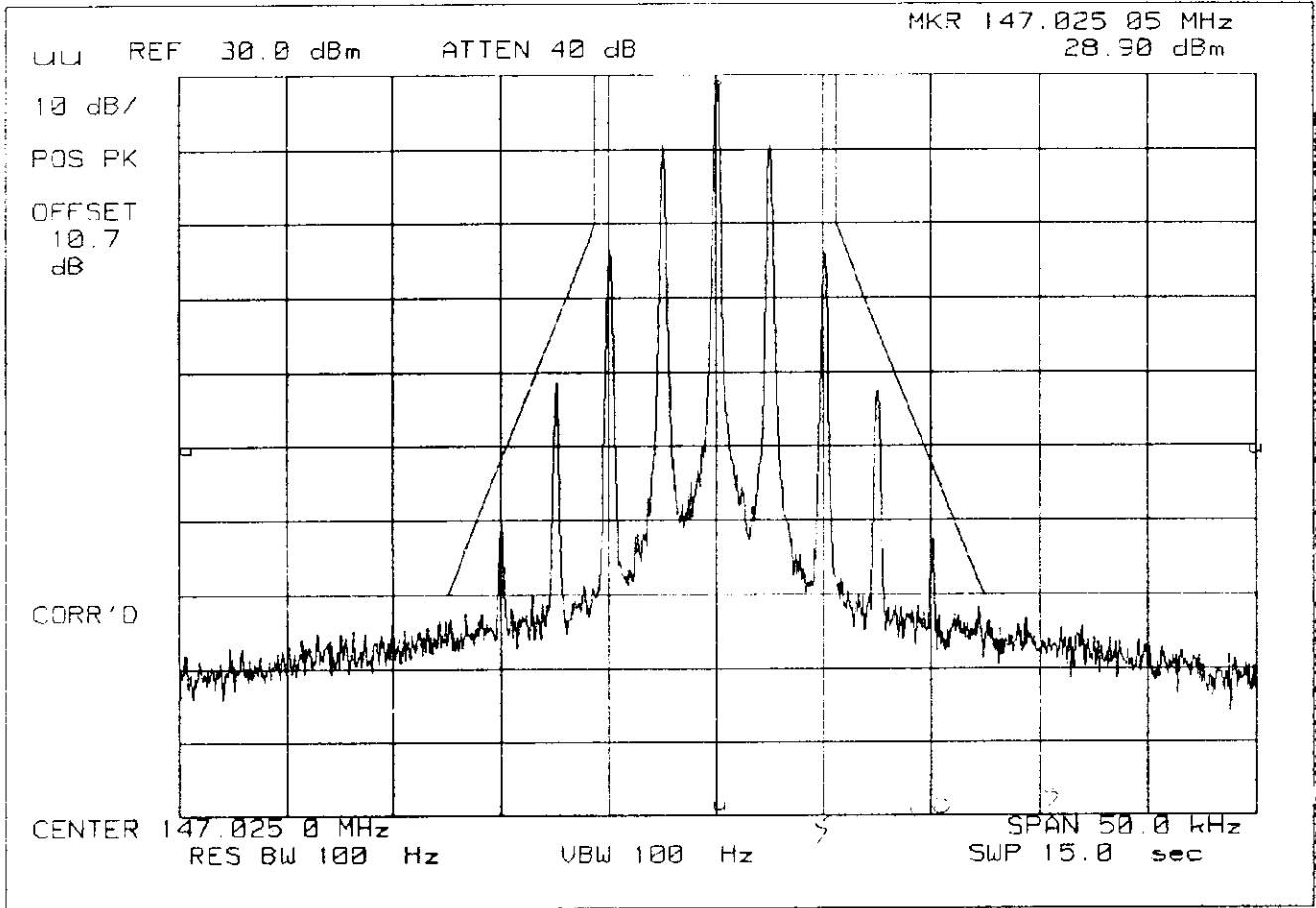

POWER: LOW  
MODULATION: VOICE: 2500 Hz SINE WAVE  
MASK: B, VHF/UHF 25kHz, w/LPF

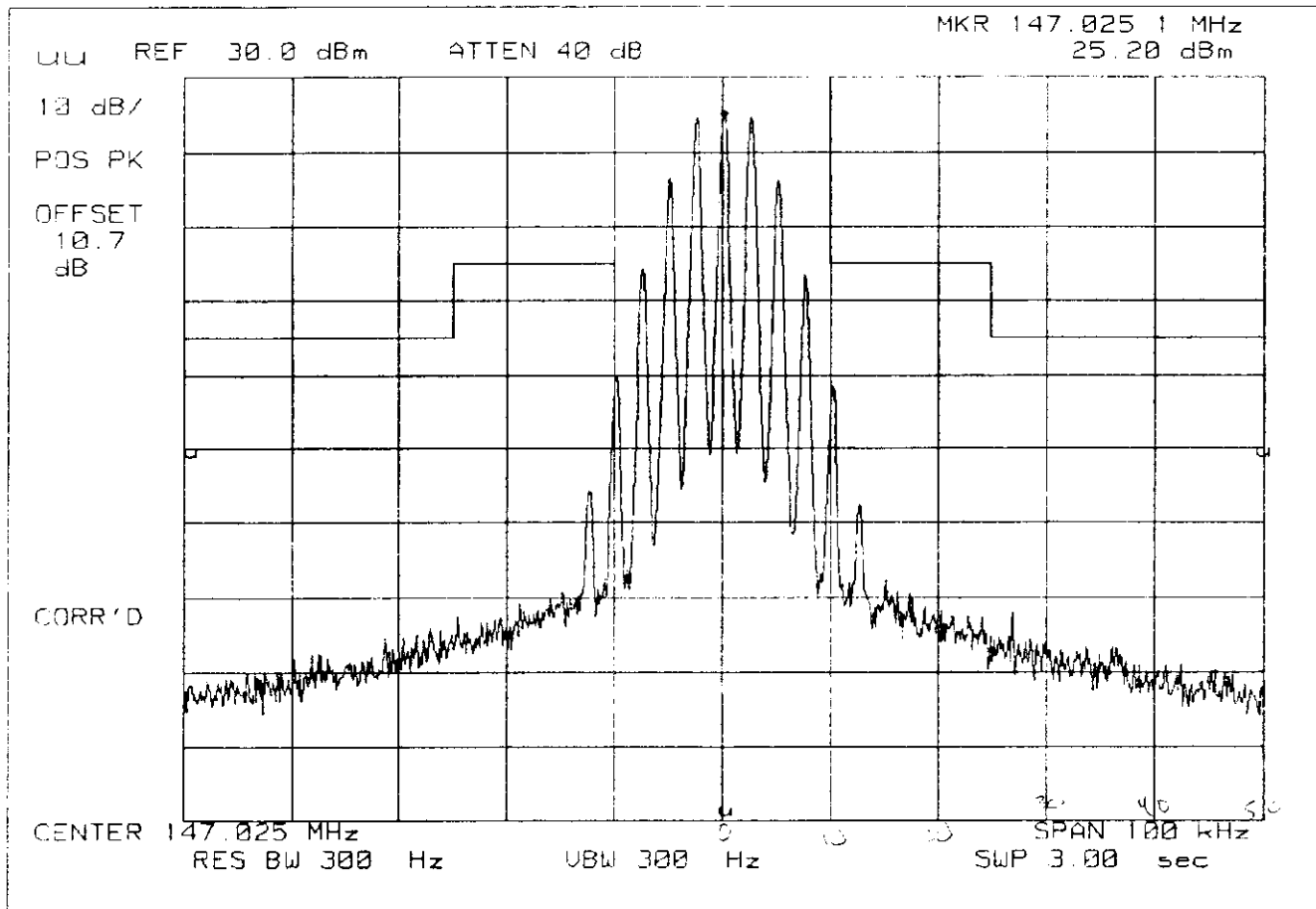

POWER: HIGH  
MODULATION: NONE

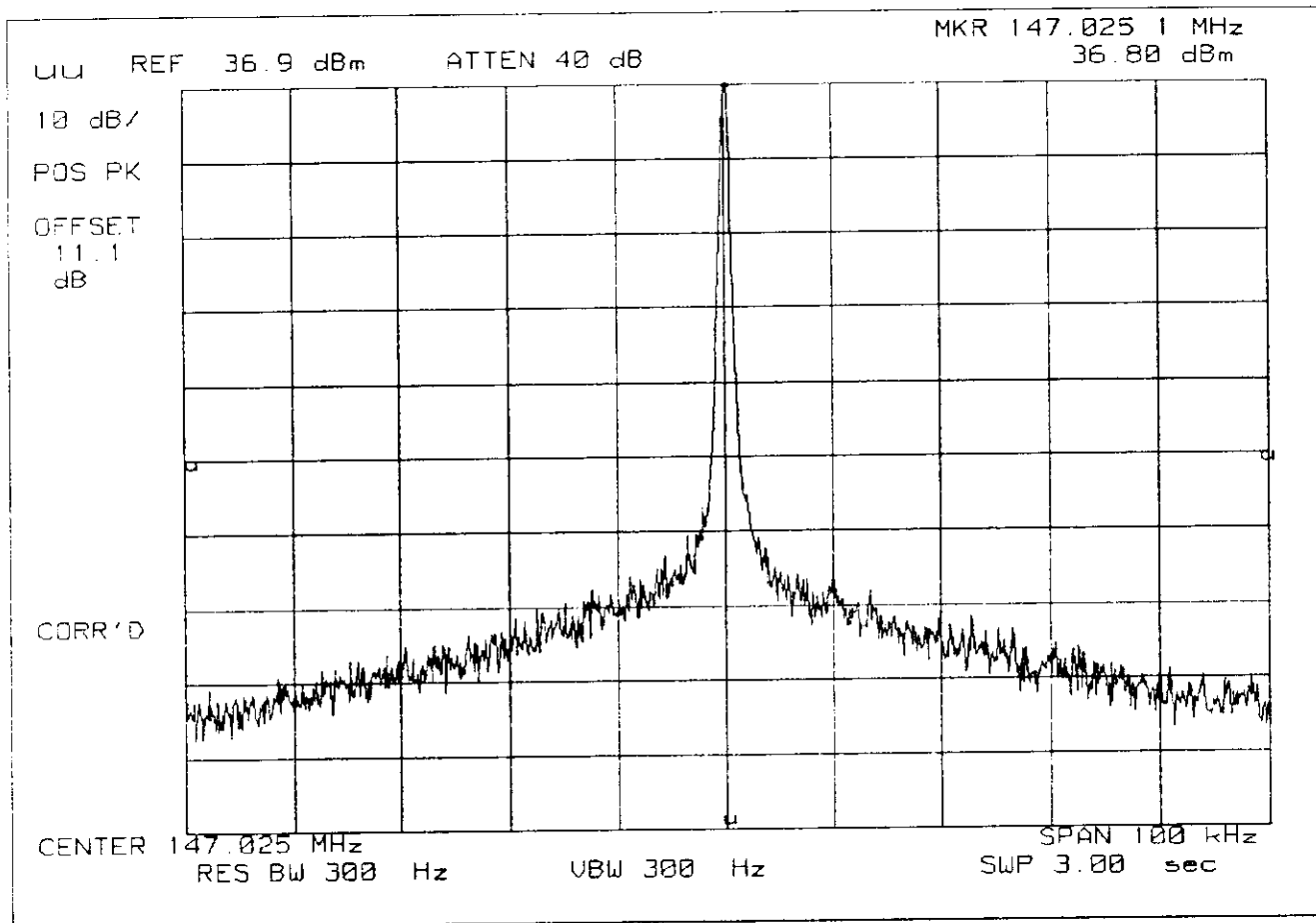

POWER: HIGH  
MODULATION: VOICE: 2500 Hz SINE WAVE  
MASK: D, VHF/UHF 12.5kHz BW

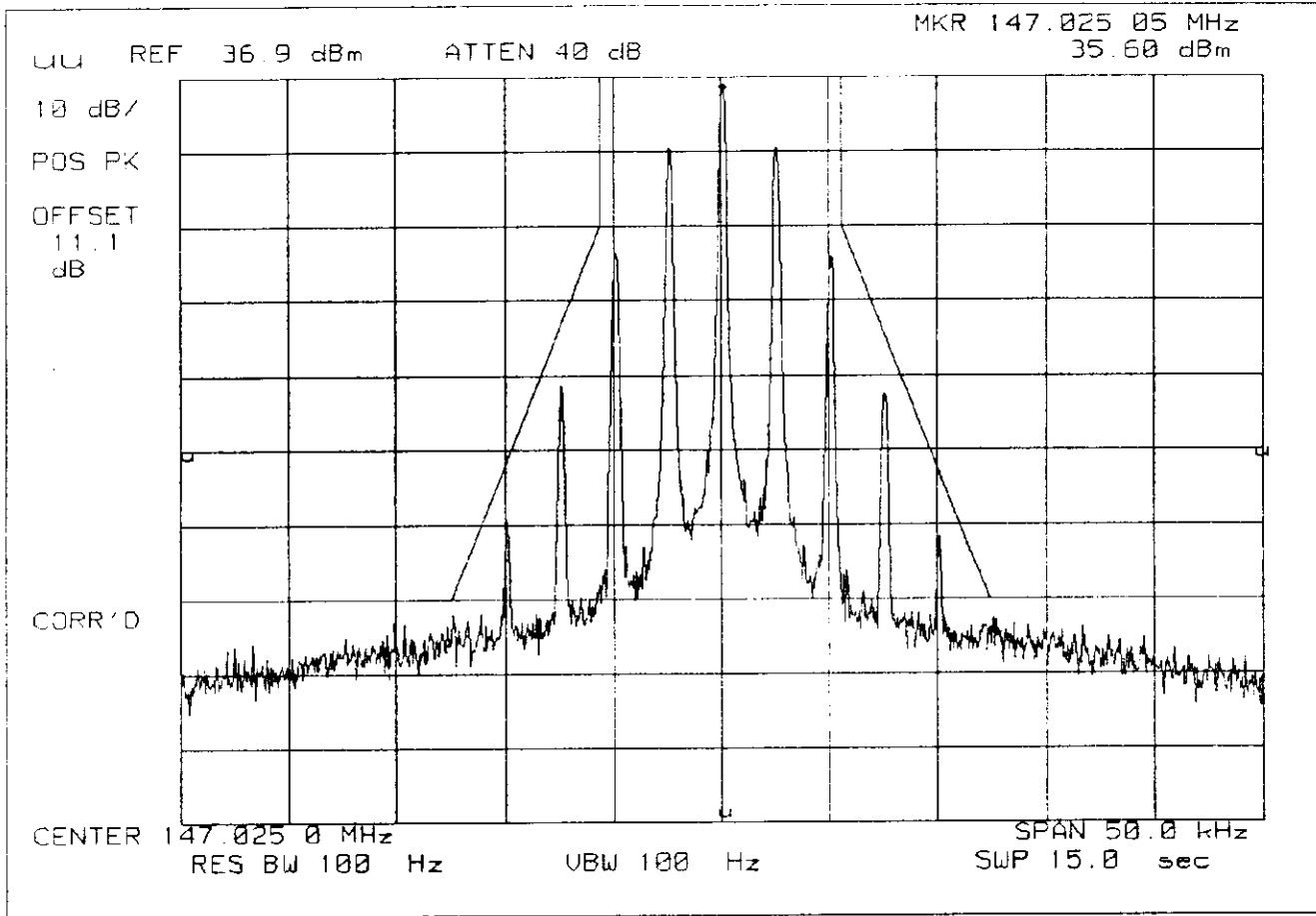

PAGE 15.6.  
SPECTRUM ANALYZER PRESENTATION  
YAESU, VX-400V-2  
1998-JUN-24, 10:36, WED

K66VX-400V-2

POWER: HIGH  
MODULATION: VOICE: 2500 Hz SINE WAVE  
MASK: B, VHF/UHF 25kHz, w/LPF

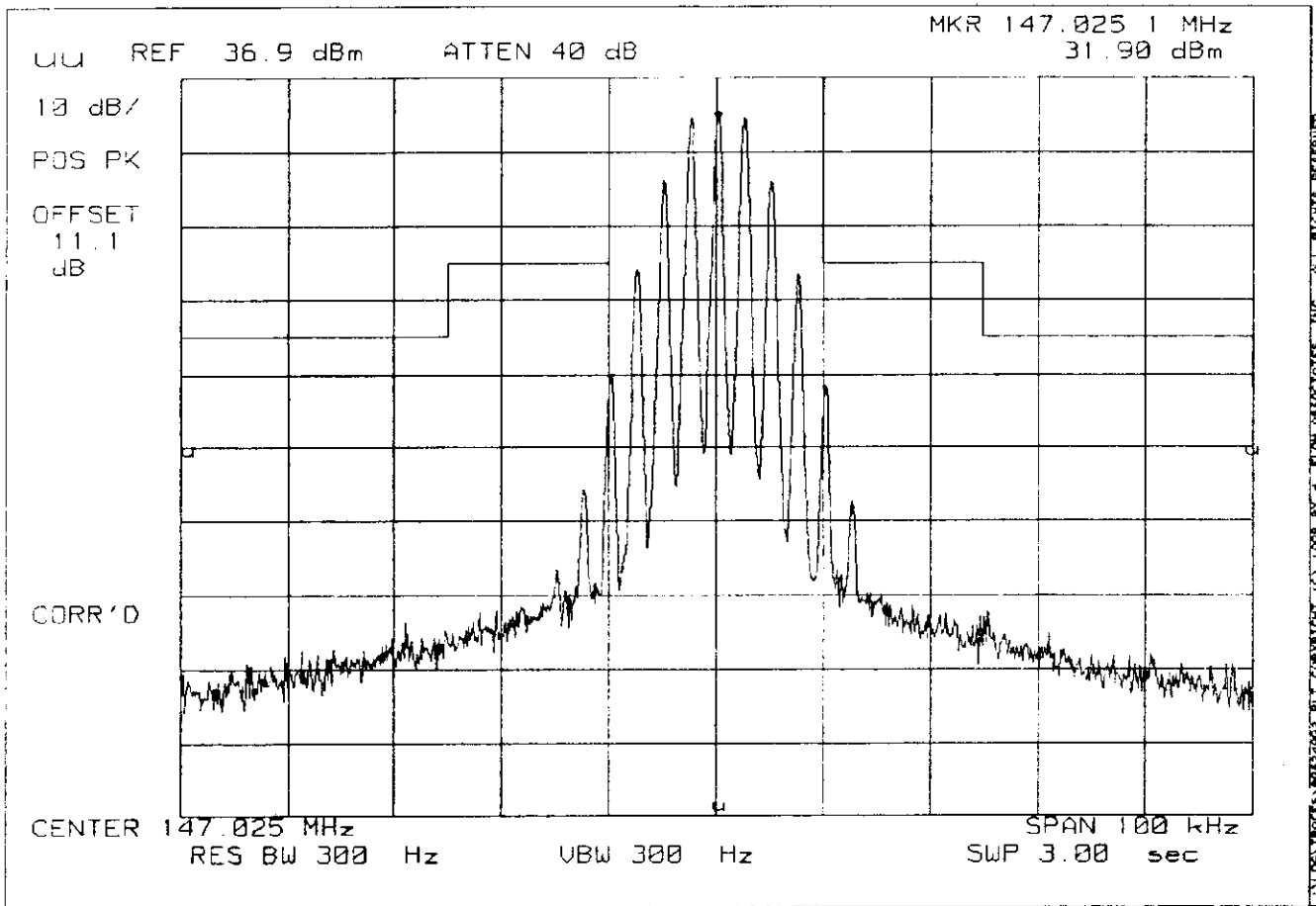



PAGE NO.

16.

K66VX-400V-2

NAME OF TEST:

Transient Frequency Behavior

SPECIFICATION:

FCC: 47 CFR 90.214  
IC: RSS-119, Section 6.5

GUIDE:

TIA/EIA-603, Paragraph 2.2.19

TEST CONDITIONS:

S. T. & H.

TEST EQUIPMENT:

As per attached page

MEASUREMENT PROCEDURE

1. The EUT was setup as shown on the attached page, following TIA/EIA-603 steps a, b, and c as a *guide*.
2. The transmitter was turned on.
3. Sufficient attenuation was provided so that the transmitter carrier level measured at the output of the combiner was 40 dB below the maximum input level of the test receiver. This level was recorded as step f.
4. The transmitter was turned off.
5. An RF signal generator (1) modulated with a 1 kHz tone at either 25, 12.5, or 6.25 kHz deviation, and set to the same frequency as the assigned transmitter frequency, (2) was adjusted to a level -20 dB below the level recorded for step f, as measured at the output of the combiner. This level was then fixed for the remainder of the test and is recorded at step h.
6. The oscilloscope was setup using TIA/EIA-603 steps j and k as a guide, and to either 10 ms/div (UHF) or 5 ms/div (VHF).
7. The 30 dB attenuator was removed, the transmitter was turned on, and the level of the carrier at the output of the combiner was recorded as step l.
8. The carrier on-time as referenced in TIA/EIA-603 steps m, n, and o was captured and plotted. The carrier off-time as referenced in TIA/EIA-603 steps p, q, r, and s was captured and plotted.

LEVELS MEASURED:

<u>step f</u> , dBm	= -13.5
<u>step h</u> , dBm	= -34.6
<u>step l</u> , dBm	= 15.7

SUPERVISED BY:



MORTON FLOM, P. Eng.

TRANSIENT FREQUENCY BEHAVIOR

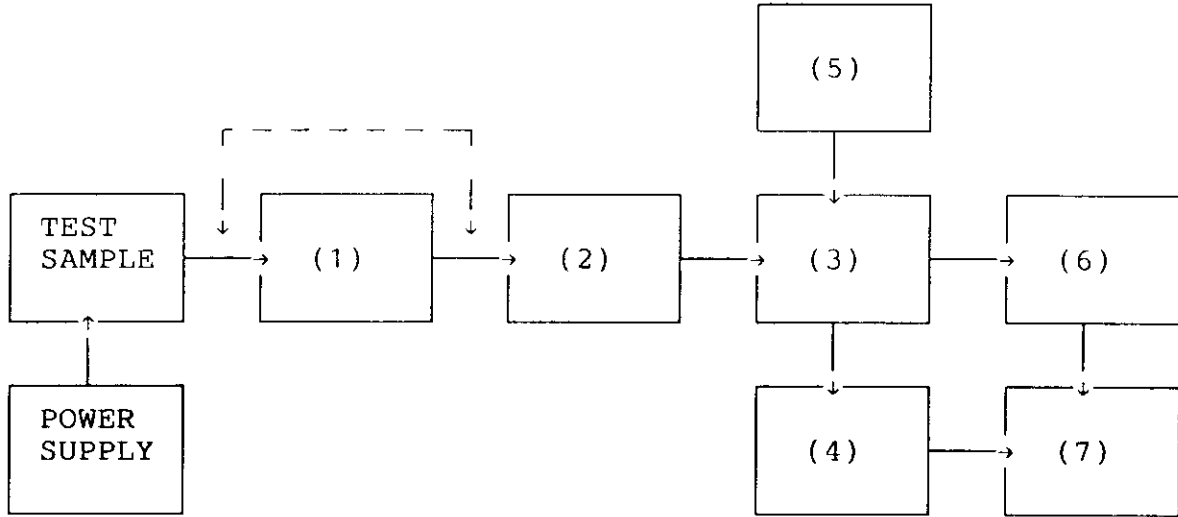

- (1) ATTENUATOR  
 (NOTE: Removed after 1st step)  
 30 dB   x
- (2) ATTENUATOR  
 30 dB             
 20 dB   x    
 10 dB             
 KAY VARIABLE
- (3) COMBINER  
 4 x 25 Ω COMBINER   x
- (4) CRYSTAL DETECTOR  
 HP 8470B   x
- (5) RF SIGNAL GENERATOR  
 HP 8656A             
 HP 8920A   x
- (6) MODULATION ANALYZER  
 HP 8901A   x
- (7) SCOPE  
 HP 54502A   x

MODULATION: Ref Gen=12.5 kHz Deviation  
 REMARK: CARRIER ON TIME

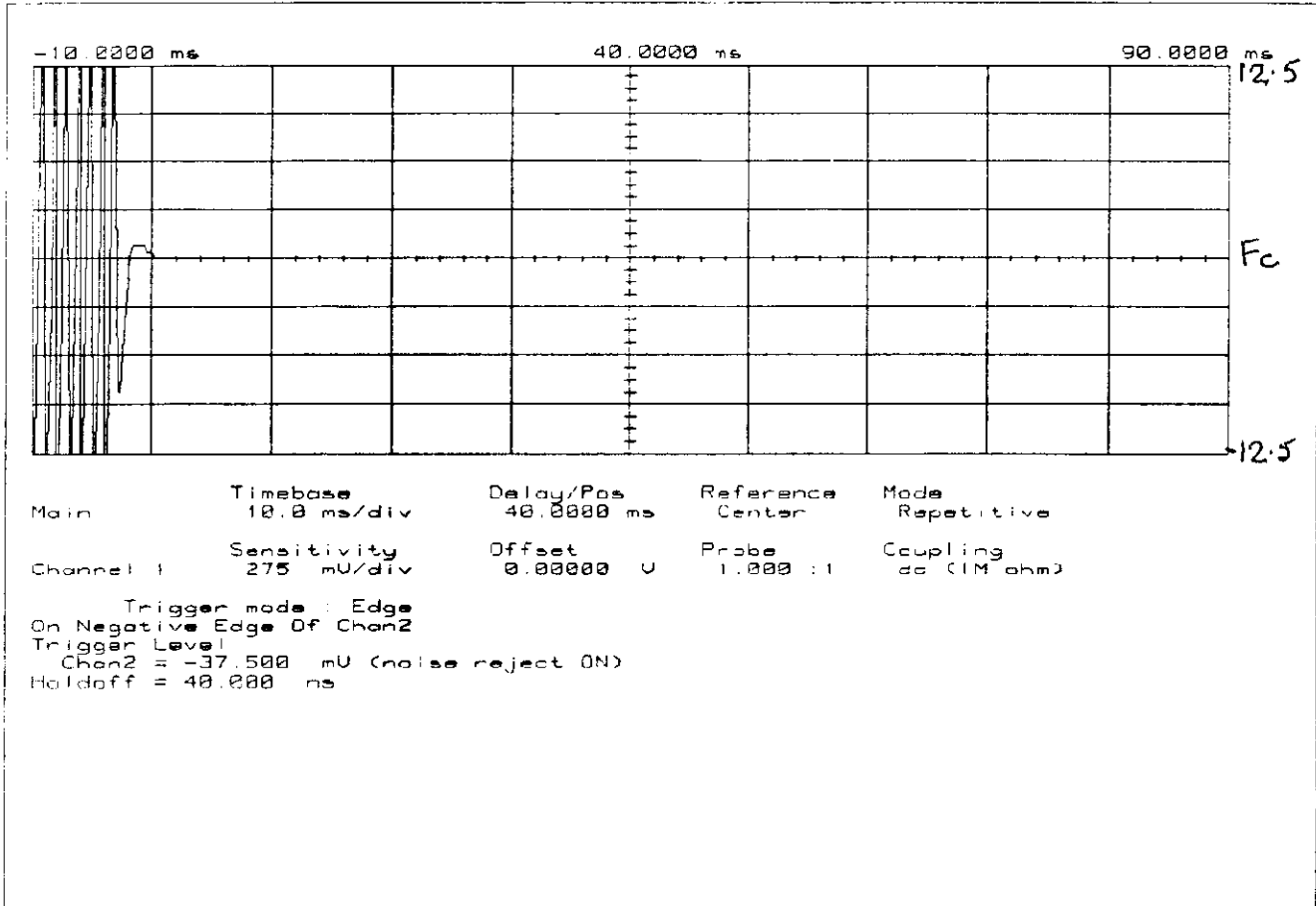

MODULATION: Ref Gen=12.5 kHz Deviation  
 REMARK: CARRIER OFF TIME

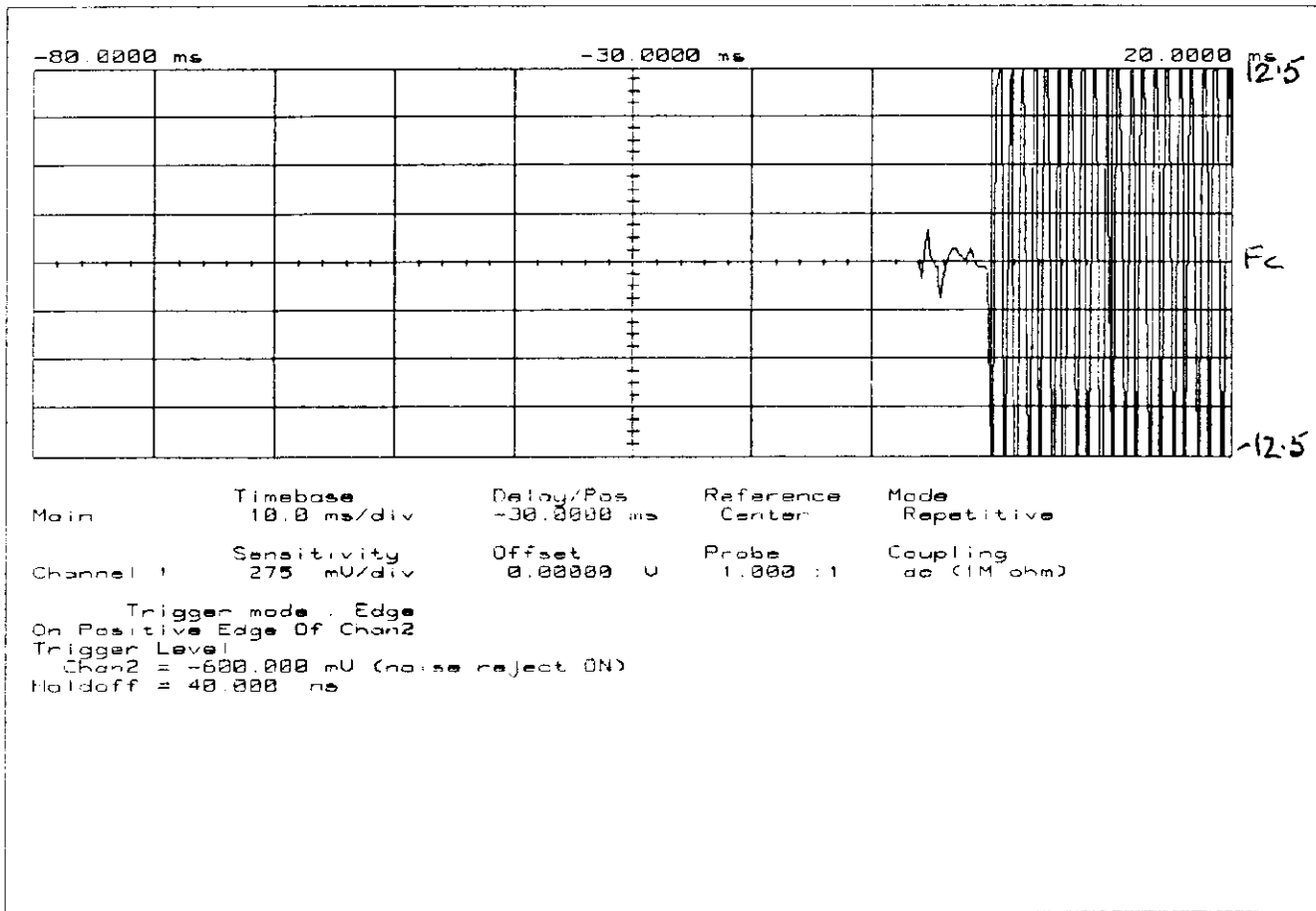

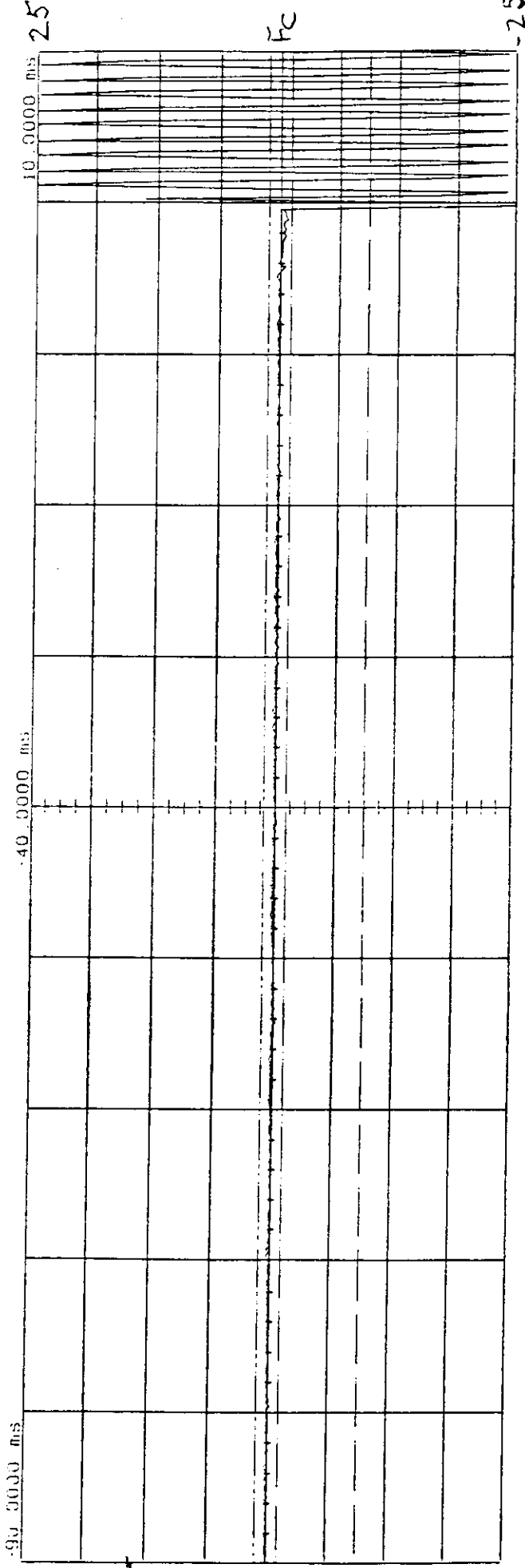

Channel 1  
 Timebase 10.0 ms/div  
 Sensitivity 0.80 mV/div  
 Delay/Pos -40.0000 ms  
 Offset 1.50000 V  
 Mode Repetitive  
 Reference Center  
 Probe 1.000 .1  
 Coupling dc (IM ohm)

Trigger mode Edge  
 On Negative Edge Of Chan2  
 Trigger Level  
 Chord = 1.75000 V (noise reject OFF)  
 Bandoff = 40.000 ns

Model Name : VX-400V  
 Serial Number : 8H001301  
 Channel Spacing : 25 [kHz]  
 Frequency : 134.025 [MHz]

**TRANSIENT FREQUENCY BEHAVIOUR (PARAGRAPH 2.2.19)**

I3 : 5 [mS]  
 Af1 : 25 [kHz]  
 Δf3 : 670 [Hz]

Modulation : NONE  
 Power : HIGH, 5 [W]

90.0000 ms

Fe

-25

40.0000 ms

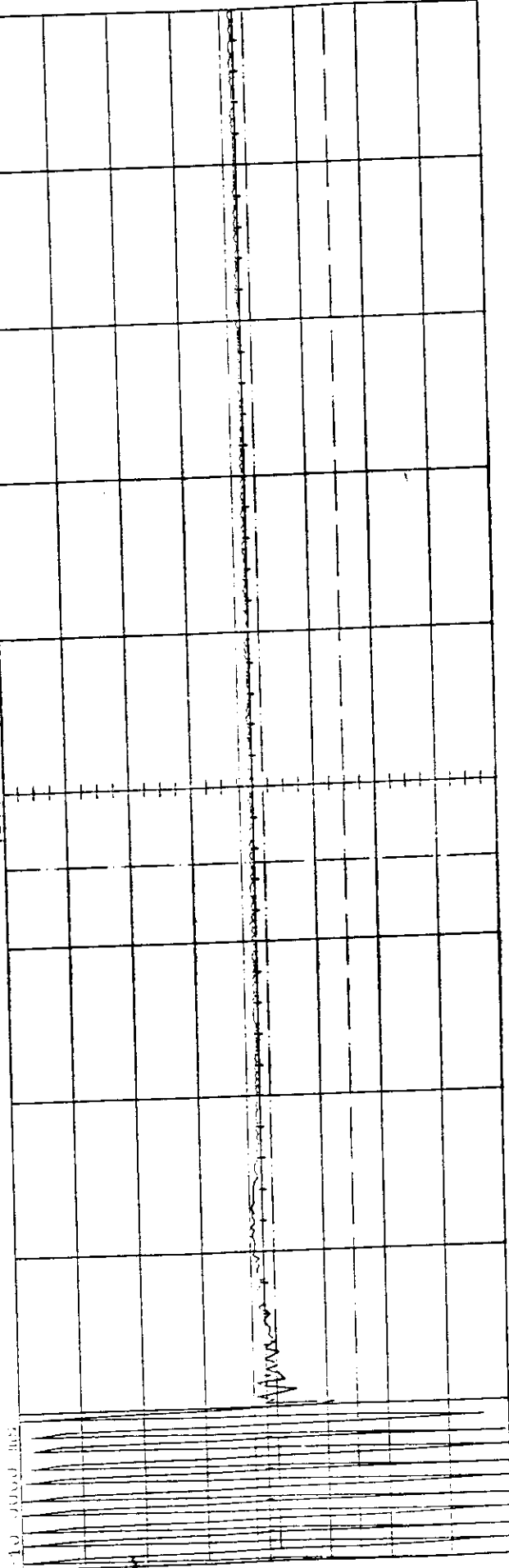

Markers

Vmarker2 (c1)	=	1.51300	V
Vmarker1 (c1)	=	1.48750	V
delta V (c1)	=	25.500	mV
stop	=	35.0000	ms
start	=	0.00000	s
delta t	=	35.0000	ms
1/delta t	=	28.5714	Hz

Mode  
Repetitive

Coupling  
ac (1M ohm)

Reference  
Center

Probe  
1.000 : 1

Delay/Pos  
40.0000 ms

Offset  
1.50000 V

Timebase  
10.0 ms/div

Sensitivity  
60.0 mV/div

Trigger mode : Edge

On Positive Edge Of Chan2

Trigger level

Channel 1 = 1.75000 V (noise reject OFF)

Threshold = 40.000 ms

TRANSIENT FREQUENCY BEHAVIOUR (PARAGRAPH 2.2.19)

T1	: 5 [mS]
T2	: 20 [mS]
Δf1	: 25 [kHz]
Δf2	: 12.5 [kHz]
Δf3	: 670 [Hz]

Modulation : NONE

Power : HIGH, 5 [W]

Model Name : VX-400V

Serial Number : 8H001301

Channel Spacing : 25 [kHz]

Frequency : 134.025 [MHz]

PAGE NO.

19.

K66VX-400V-2

NAME OF TEST:

Audio Low Pass Filter (Voice Input)

SPECIFICATION:

FCC: 47 CFR 2.987(a)  
IC: RSS-119, Section 6.6

GUIDE:

TIA/EIA-603, Paragraph 2.2.15

TEST CONDITIONS:

S. T. & H.

TEST EQUIPMENT:

As per attached page

MEASUREMENT PROCEDURE

1. The EUT and test equipment were set up such that the audio input was connected at the input to the modulation limiter, and the modulated stage.
2. The audio output was connected at the output to the modulated stage.
3. MEASUREMENT RESULTS: ATTACHED

TRANSMITTER TEST SET-UP

- TEST A. MODULATION CAPABILITY/DISTORTION
- TEST B. AUDIO FREQUENCY RESPONSE
- TEST C. HUM AND NOISE LEVEL
- TEST D. RESPONSE OF LOW PASS FILTER
- TEST E. MODULATION LIMITING

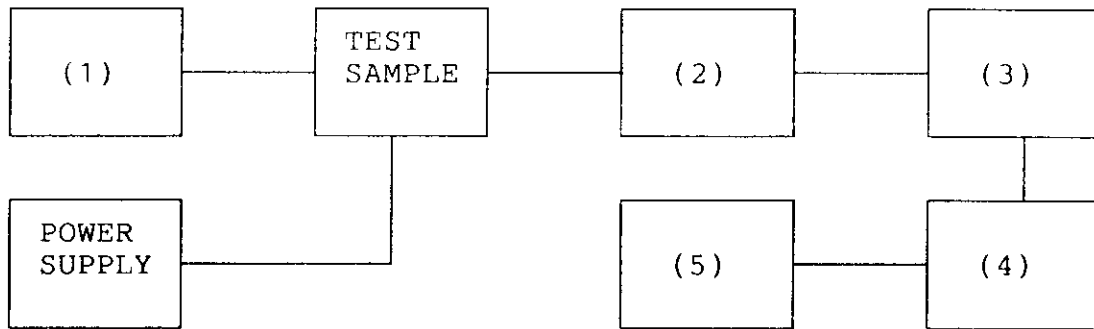

(1) AUDIO OSCILLATOR/GENERATOR

HP 204D	---
HP 8903A	---
HP 3312A	<u>x</u>
_____	<u>x</u>

(2) COAXIAL ATTENUATOR

NARDA 766-10	---
SIERRA 661A-30	<u>x</u>
BIRD 8329 (30 dB)	---
_____	---

(3) MODULATION ANALYZER

HP 8901A	<u>x</u>
_____	---

(4) AUDIO ANALYZER

HP 8903A	<u>x</u>
_____	---

(5) SCOPE

HP 1741A	---
HP 181T	---
TEK 935	---
_____	---



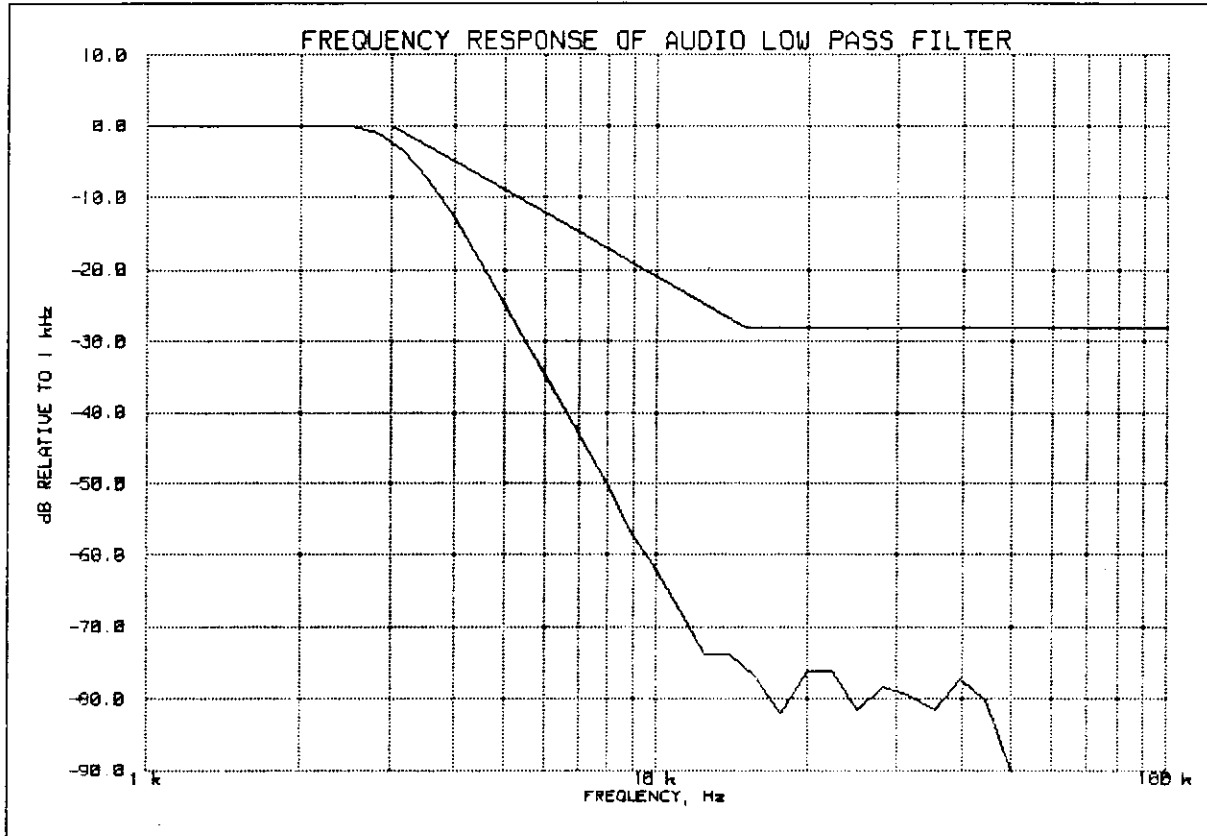

PEAK AUDIO FREQUENCY, Hz: 2510

SUPERVISED BY:

*Morton Flom P. Eng.*

MORTON FLOM, P. Eng.

PAGE NO.

22.

K66VX-400V-2

NAME OF TEST:

Audio Frequency Response

SPECIFICATION:

FCC: 47 CFR 2.987(a)

IC: N/A

GUIDE:

TIA/EIA-603, Section 2.2.6

TEST CONDITIONS:

S. T. & H.

TEST EQUIPMENT:

As per previous page

#### MEASUREMENT PROCEDURE

1. The EUT and test equipment were set up as shown on the following page.
2. The audio signal generator was connected to the audio input circuit/microphone of the EUT.
3. The audio signal input was adjusted to obtain 20% modulation at 1 kHz, and this point was taken as the 0 dB reference level.
4. With input levels held constant and below limiting at all frequencies, the audio signal generator was varied from 100 Hz to 50 kHz.
5. The response in dB relative to 1 kHz was then measured, using the HP 8901A Modulation Analyzer.
6. MEASUREMENT RESULTS: ATTACHED

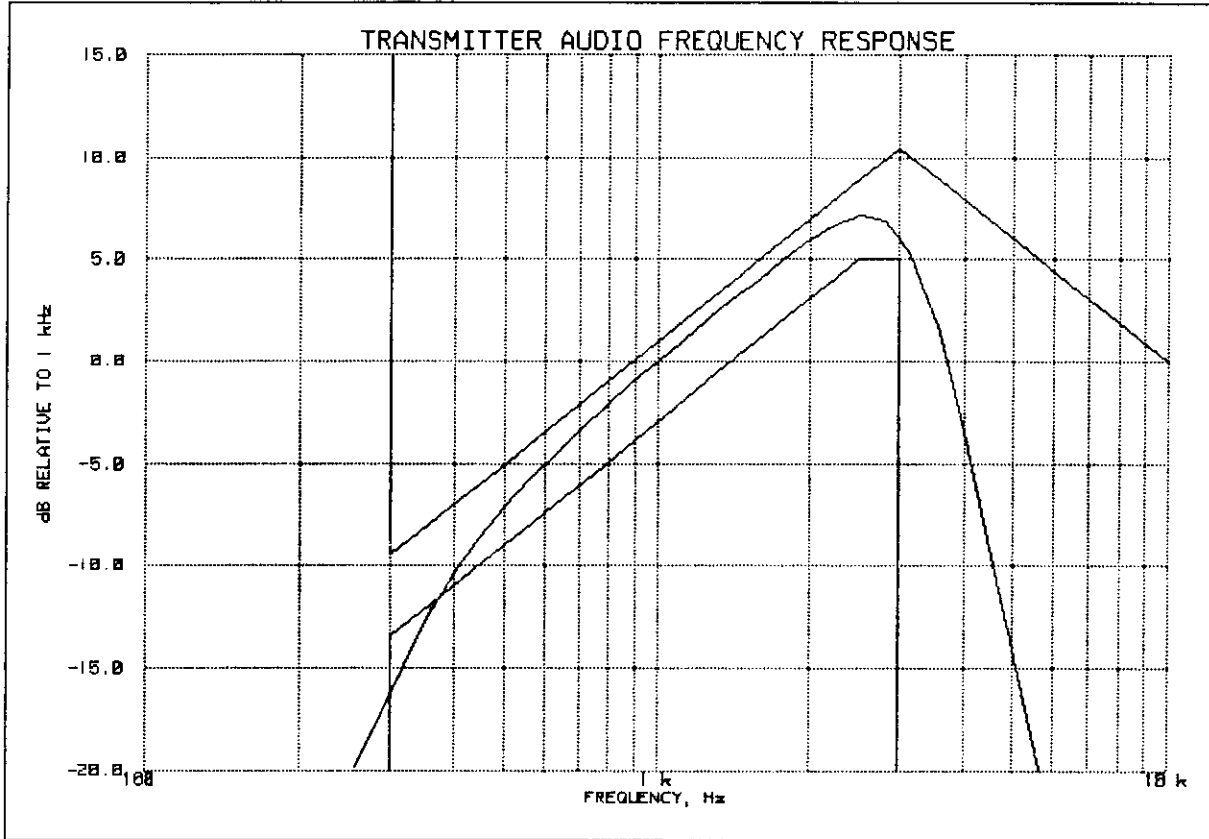

PEAK AUDIO FREQUENCY, Hz: 2510

TABLE VALUES:

FREQUENCY, Hz	LEVEL, dB	FREQUENCY, Hz	LEVEL, dB	FREQUENCY, Hz	LEVEL, dB
300	-16.3	30000	-27.5		
20000	-27.5	50000	-27.5		

*Morton Flom P. Eng.*

SUPERVISED BY:

MORTON FLOM, P. Eng.

PAGE NO.

24.

K66VX-400V-2

NAME OF TEST:

Modulation Limiting

SPECIFICATION:

IC: RSS-119, Section 6.6  
FCC: 47 CFR 2.987(b)

GUIDE:

TIA/EIA-603, Paragraph 2.2.3

TEST CONDITIONS:

S. T. & H.

TEST EQUIPMENT:

As per attached page

MEASUREMENT PROCEDURE

1. The signal generator was connected to the input of the EUT as for "Frequency Response of the Modulating Circuit."
2. The modulation response was measured for each of three frequencies (one of which was the frequency of maximum response), and the input voltage was varied and was observed on an HP 8901A Modulation Analyzer.
3. The input level was varied from 30% modulation ( $\pm 1.5$  kHz deviation) to at least 20 dB higher than the saturation point.
4. Measurements were performed for both negative and positive modulation and the respective results were recorded.
5. MEASUREMENT RESULTS: ATTACHED

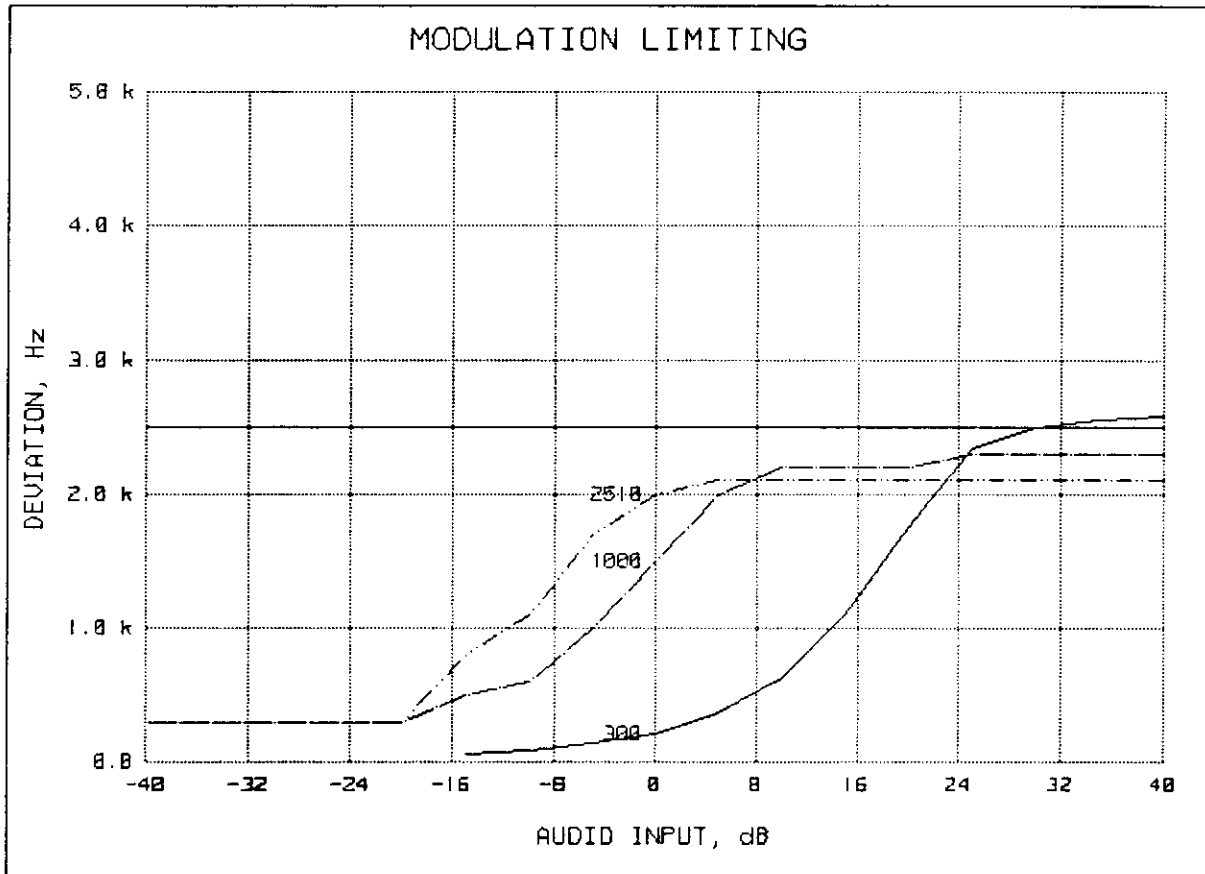

REFERENCE DEVIATION, kHz = 1.25  
REFERENCE MODULATION, Hz = 1000  
PEAKS = POSITIVE  
AUDIO AMPLITUDE, mV = 5.74

SUPERVISED BY:

*Morton Flom P. Eng.*

MORTON FLOM, P. Eng.

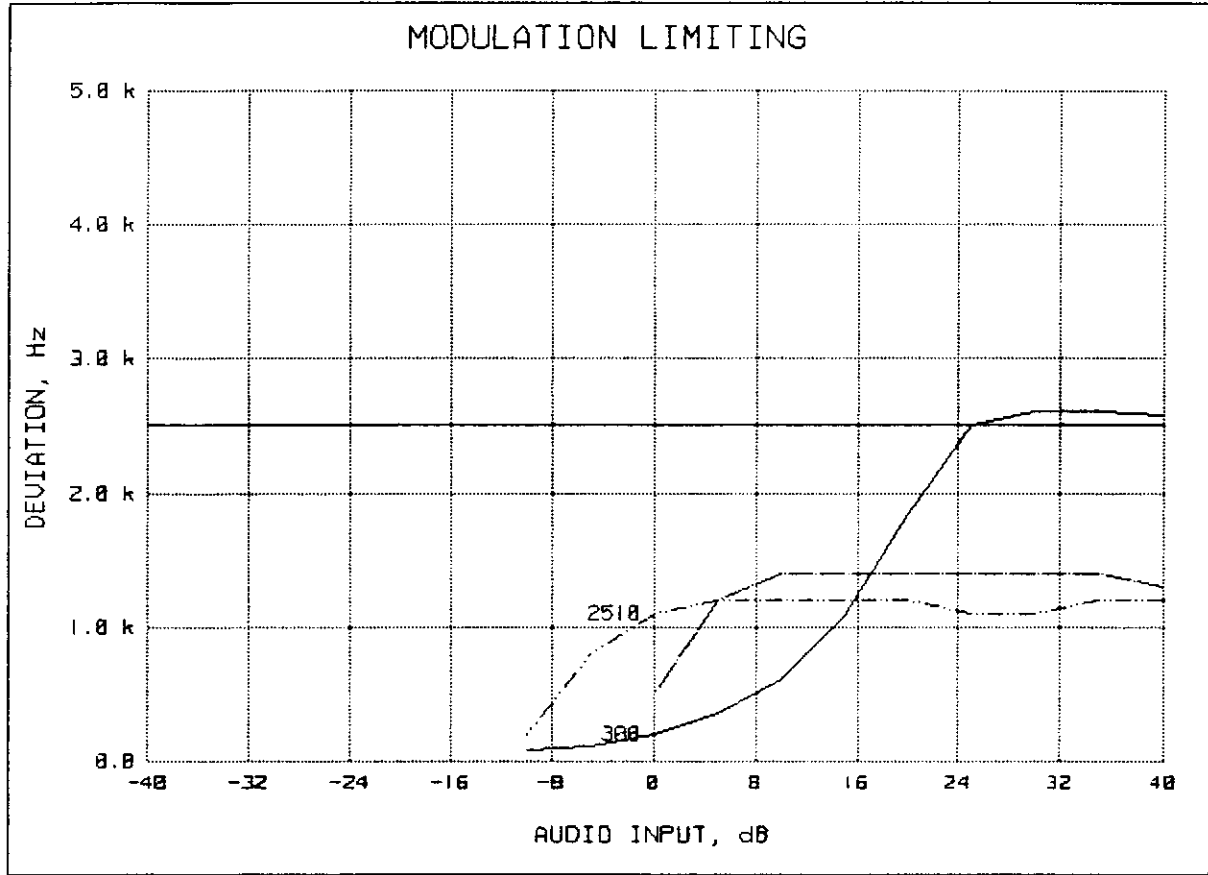

REFERENCE DEVIATION, kHz = 1.25  
 REFERENCE MODULATION, Hz = 1000  
 PEAKS = NEGATIVE  
 AUDIO AMPLITUDE, mV = 5.74

*Morton Flom P. Eng.*

SUPERVISED BY:

MORTON FLOM, P. Eng.

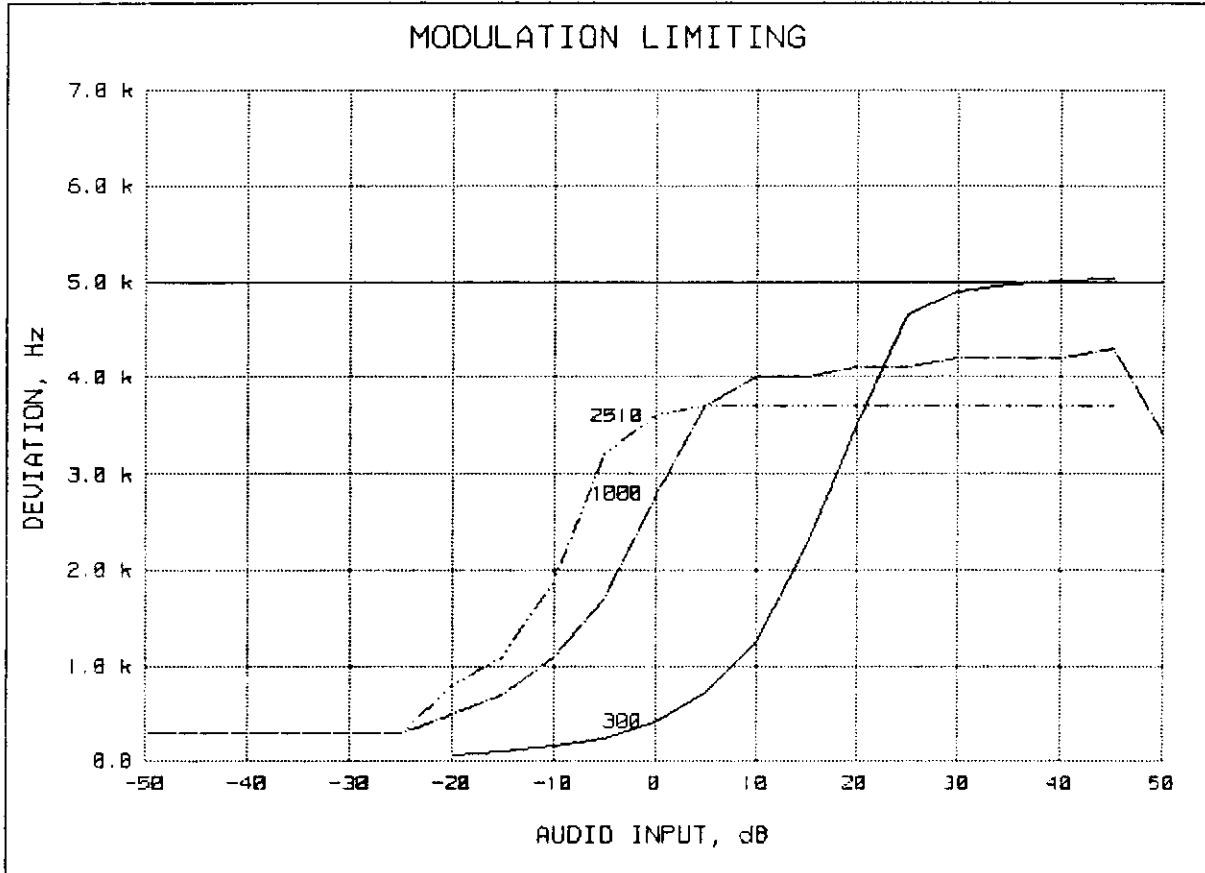

REFERENCE DEVIATION, kHz = 2.5  
REFERENCE MODULATION, Hz = 1000  
PEAKS = POSITIVE  
AUDIO AMPLITUDE, mV = 6.15

SUPERVISED BY:

*Morton P. Eng.*

MORTON FLOM, P. Eng.

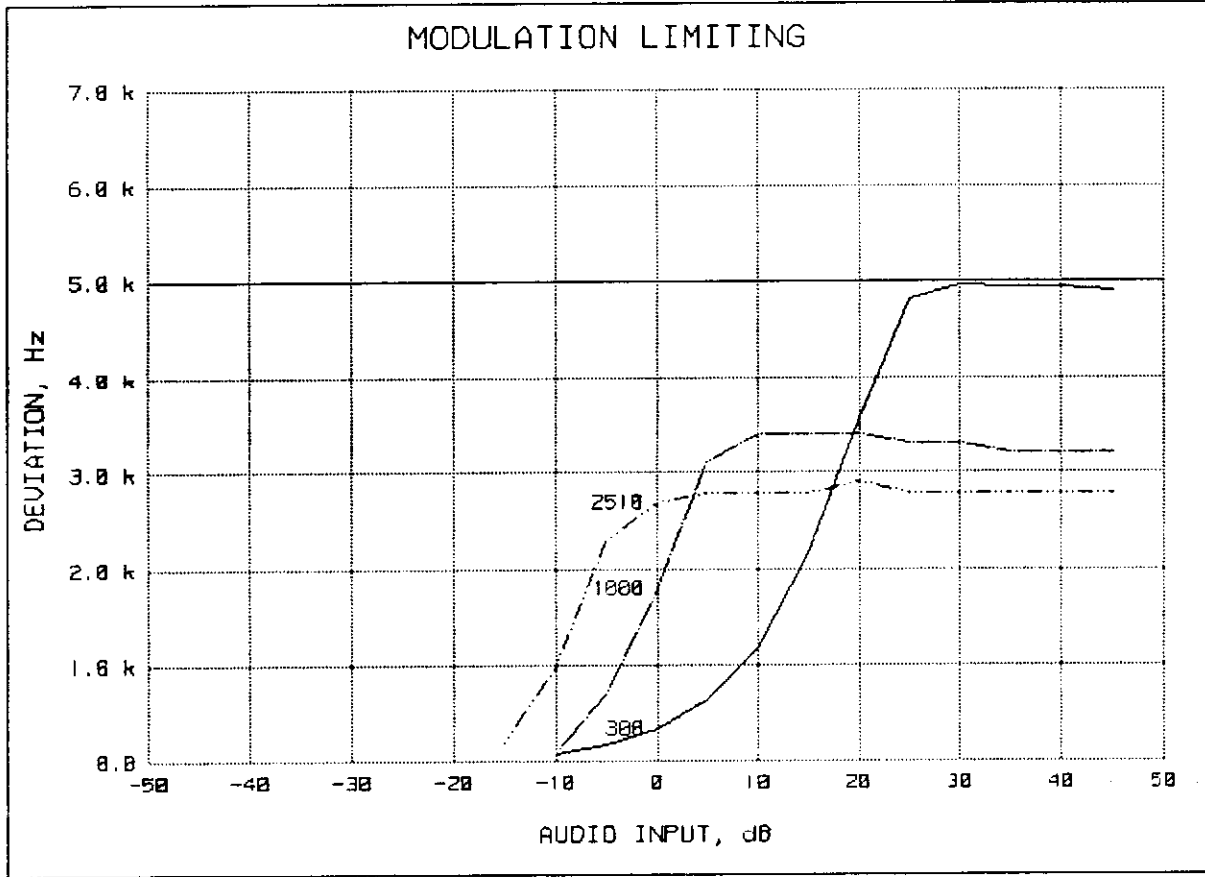

REFERENCE DEVIATION, kHz	= 2.5
REFERENCE MODULATION, Hz	= 1000
PEAKS	= NEGATIVE
AUDIO AMPLITUDE, mV	= 6.15

SUPERVISED BY:

*Morton P. Flom*

MORTON FLOM, P. Eng.



PAGE NO. 26. K66VX-400V-2  
NAME OF TEST: Frequency Stability (Temperature Variation)  
SPECIFICATION: FCC: 47 CFR 2.995(a)(1)  
IC: RSS-119, Section 7.0  
GUIDE: TIA/EIA-602, Section 2.2.2  
TEST CONDITIONS: As indicated  
TEST EQUIPMENT: As per attached page

MEASUREMENT PROCEDURE

1. The EUT and test equipment were set up as shown on the following page.
2. With all power removed, the temperature was decreased to  $-30^{\circ}\text{C}$  and permitted to stabilize for three hours. Power was applied and the maximum change in frequency was noted within one minute.
3. With power OFF, the temperature was raised in  $10^{\circ}\text{C}$  steps. The sample was permitted to stabilize at each step for at least one-half hour. Power was applied and the maximum frequency change was noted within one minute.
4. The temperature tests were performed for the worst case.
5. MEASUREMENT RESULTS: ATTACHED

TRANSMITTER TEST SET-UP

- TEST A. OPERATIONAL STABILITY
- TEST B. CARRIER FREQUENCY STABILITY
- TEST C. OPERATIONAL PERFORMANCE STABILITY
- TEST D. HUMIDITY
- TEST E. VIBRATION
- TEST F. ENVIRONMENTAL TEMPERATURE
- TEST G. FREQUENCY STABILITY: TEMPERATURE VARIATION
- TEST H. FREQUENCY STABILITY: VOLTAGE VARIATION

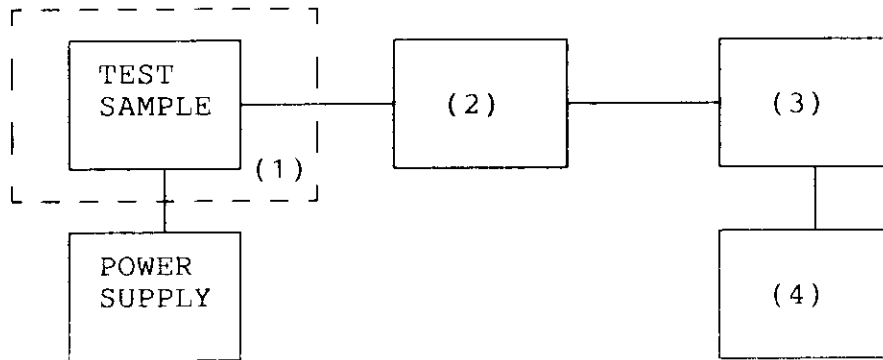

(1) TEMPERATURE, HUMIDITY, VIBRATION

TENNEY TEMPERATURE CHAMBER	<u>  x  </u>
WEBER HUMIDITY CHAMBER	<u>      </u>
L.A.B. RVH 18-100	<u>      </u>
<hr/>	

(2) COAXIAL ATTENUATOR

NARDA 766-10	<u>      </u>
SIERRA 661A-30	<u>  x  </u>
BIRD 8329 (30 dB)	<u>  x  </u>
<hr/>	

(3) R.F. POWER

HP 435A POWER METER	<u>      </u>
HP 436A POWER METER	<u>  x  </u>
HP 8901A POWER MODE	<u>  x  </u>
<hr/>	

(4) FREQUENCY COUNTER

HP 5383A	<u>      </u>
HP 5334B	<u>  x  </u>
HP 8901A	<u>  x  </u>
<hr/>	

PAGE 28  
TRANSMITTER FREQUENCY STABILITY  
YAESU, VX-400V-2  
24 JUN 1998, 14:52

K66VX-400V-2

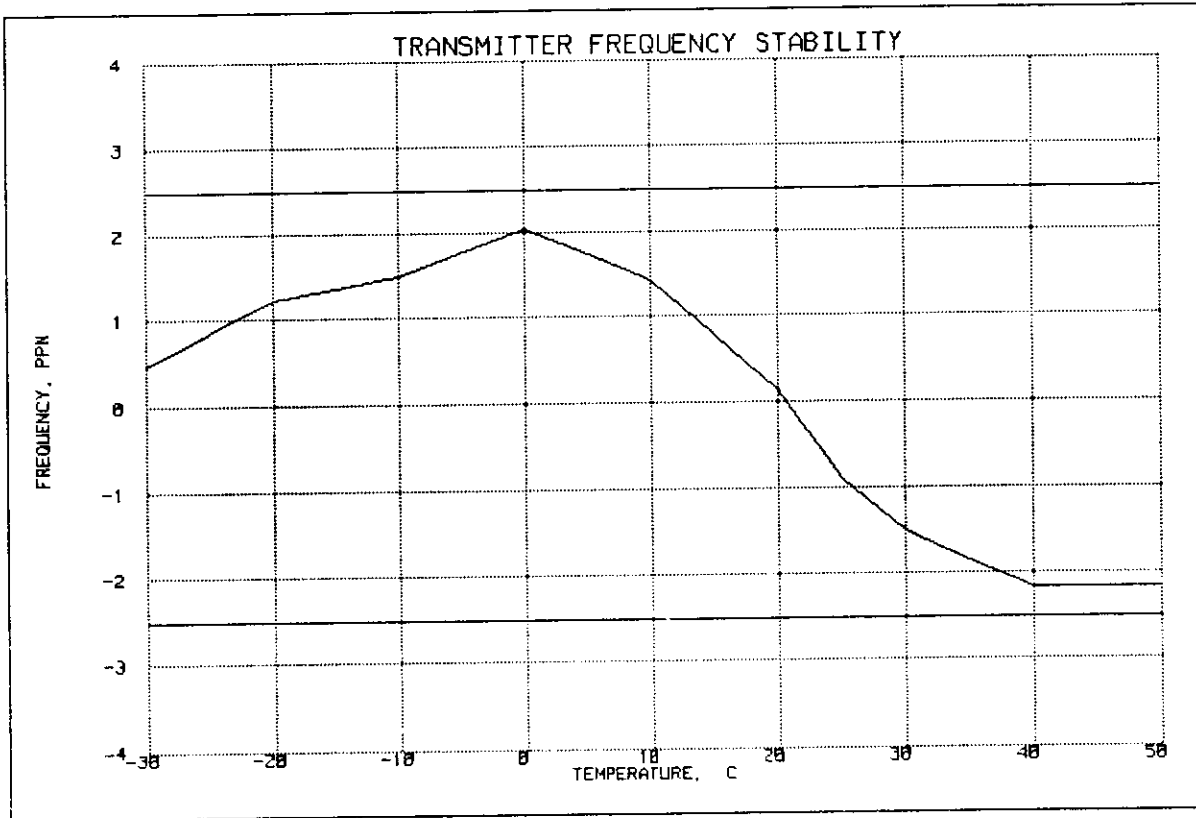

FREQUENCY OF CARRIER, MHz = 147.02517

LIMIT, ppm = 2.5

LIMIT, Hz = 368

SUPERVISED BY:

*Morton Flom P. Eng.*

MORTON FLOM, P. Eng.

PAGE NO. 29. K66VX-400V-2  
NAME OF TEST: Frequency Stability (Voltage Variation)  
SPECIFICATION: FCC: 47 CFR 2.995 (b)(1)  
IC: RSS-119, Section 7.0  
GUIDE: TIA/EIA-602, Section 2.2.2  
TEST CONDITIONS: As indicated  
TEST EQUIPMENT: As per attached page

MEASUREMENT PROCEDURE

1. The EUT was placed in a temperature chamber at 25±5°C and connected as for "Frequency Stability - Temperature Variation" test.
2. The power supply voltage to the EUT was varied from 85% to 115% of the nominal value measured at the input to the EUT.
3. The variation in frequency was measured for the worst case.

MEASUREMENT RESULTS

LIMIT, ppm = 2.5  
LIMIT, Hz = 368

STV, %	Vdc	<u>CHANGE IN FREQUENCY, Hz</u>	
85	6.1	147024990	-10
100	7.2	147025000	0
115	8.3	147025010	10
BATTERY END POINT:	6.7	147025010	10

SUPERVISED BY:

*M. J. F. Eng.*  
MORTON FLOM, P. Eng.

PAGE NO.

30.

K66VX-400V-2

NAME OF TEST:

Necessary Bandwidth and Emission Bandwidth

PARAGRAPH:

47 CFR 2.202(g)

MODULATION = 16K0F3E

NECESSARY BANDWIDTH CALCULATION:

MAXIMUM MODULATION (M), kHz = 3  
MAXIMUM DEVIATION (D), kHz = 5  
CONSTANT FACTOR (K) = 1  
NECESSARY BANDWIDTH ( $B_N$ ), kHz =  $(2 \times M) + (2 \times D \times K)$   
= 16.0

MODULATION = 11K0F3E

NECESSARY BANDWIDTH CALCULATION:

MAXIMUM MODULATION (M), kHz = 3  
MAXIMUM DEVIATION (D), kHz = 2.5  
CONSTANT FACTOR (K) = 1  
NECESSARY BANDWIDTH ( $B_N$ ), kHz =  $(2 \times M) + (2 \times D \times K)$   
= 11.0

SUPERVISED BY:

  
MORTON FLOOM, P. Eng.

TESTIMONIAL  
AND  
STATEMENT OF CERTIFICATION

K66VX-400V-2

THIS IS TO CERTIFY:

1. THAT the application was prepared either by, or under the direct supervision of, the undersigned.
2. THAT the technical data supplied with the application was taken under my direction and supervision.
3. THAT the data was obtained on representative units, randomly selected.
4. THAT, to the best of my knowledge and belief, the facts set forth in the application and accompanying technical data are true and correct.

CERTIFYING ENGINEER:

  
MORTON FLOM, P. Eng.

## STATEMENT OF QUALIFICATIONS

### EDUCATION:

1. B. ENG. in ENGINEERING PHYSICS, 1949, McGill University, Montreal, Canada.
2. Post Graduate Studies, McGill University & Sir George Williams University, Montreal.

### PROFESSIONAL AFFILIATIONS:

1. ARIZONA SOCIETY OF PROFESSIONAL ENGINEERS (NSPE), #026 031 821.
2. ORDER OF ENGINEERS (QUEBEC) 1949. #4534.
3. ASSOCIATION OF PROFESSIONAL ENGINEERS, GEOPHYSICISTS & GEOLOGISTS OF ALBERTA #5916.
4. REGISTERED ENGINEERING CONSULTANT - GOVERNMENT OF CANADA, DEPARTMENT OF COMMUNICATIONS. Radio Equipment Approvals.
5. IEEE, Lifetime Member No. 0417204 (member since 1947).

### EXPERIENCE:

1. Research/Development/Senior Project Engineer, R.C.A. LIMITED (4 years).
2. Owner/Chief Engineer of Electronics. Design/Manufacturing & Cable TV Companies (10 years).
3. CONSULTING ENGINEER (over 25 years).

  
MORTON FLOM, P. Eng.

