

MFA **M. Flom Associates, Inc. - Global Compliance Center**
3356 North San Marcos Place, Suite 107, Chandler, Arizona 85225-7176
www.mflom.com general@mflom.com (480) 926-3100, FAX: 926-3598

Date: April 4, 2002

Federal Communications Commission
Via Electronic Filing

Attention: Authorization & Evaluation Division

Applicant: Vertex Standard Co., Ltd.
Equipment: GX1255S
FCC ID: K66GX1255S
FCC Rules: 2, 15, 80, T, U, R, S

Gentlemen:

On behalf of the Applicant, enclosed please find Application Form 731, Engineering Test Report and all pertinent documentation, the whole for approval of the referenced equipment as shown.

Filing fees are attached.

We trust the same is in order. Should you need any further information, kindly contact the writer who is authorized to act as agent.

Sincerely yours,



Morton Flom, P. Eng.

enclosure(s)
cc: Applicant
MF/cvr

LIST OF EXHIBITS
(FCC **CERTIFICATION** (TRANSMITTERS) - REVISED 9/28/98)

APPLICANT: Vertex Standard Co., Ltd.

FCC ID: K66GX1255S

BY APPLICANT:

- | | |
|---|---|
| 1. LETTER OF AUTHORIZATION | x |
| 2. IDENTIFICATION DRAWINGS, 2.1033(c)(11) | |
| <u> x </u> LABEL | |
| <u> x </u> LOCATION OF LABEL | |
| <u> x </u> COMPLIANCE STATEMENT | |
| <u> x </u> LOCATION OF COMPLIANCE STATEMENT | |
| 3. PHOTOGRAPHS, 2.1033(c)(12) | x |
| 4. DOCUMENTATION: 2.1033(c) | |
| (3) USER MANUAL | x |
| (9) TUNE-UP/ALIGNMENT PROCEDURE | x |
| (10) SCHEMATIC DIAGRAM | x |
| (10) OPERATIONAL DESCRIPTION | x |
| BLOCK DIAGRAM | x |
| PARTS LIST | x |
| ACTIVE DEVICES | x |
| 5. PART 80 ATTESTATION | x |
| 6. REQUEST FOR CONFIDENTIALITY | x |
| 7. MPE Report | x |

BY M.F.A. INC.

- A. TESTIMONIAL & STATEMENT OF CERTIFICATION
- B. STATEMENT OF QUALIFICATIONS

MFA **M. Flom Associates, Inc. - Global Compliance Center**
3356 North San Marcos Place, Suite 107, Chandler, Arizona 85225-7176
www.mflom.com general@mflom.com (480) 926-3100, FAX: 926-3598

T R A N S M I T T E R C E R T I F I C A T I O N

of

FCC ID: K66GX1255S
MODEL: GX1255S

to

FEDERAL COMMUNICATIONS COMMISSION

Rule Part(s) 2, 15, 80, T, U, R, S

DATE OF REPORT: April 4, 2002

ON THE BEHALF OF THE APPLICANT:

Vertex Standard Co., Ltd.

AT THE REQUEST OF:

P.O. UPS 3/26/2002

Vertex Standard USA Inc.
10900 Walker Street
Cypress, CA 90630

Attention of:

Mikio Maruya, Executive Vice President
(800) 255-9237; FAX: (800) 477-9237
(714) 827-7600; FAX: -8100
m.maruya@vxstdusa.com

SUPERVISED BY:

Morton Flom, P. Eng.

THE APPLICANT HAS BEEN CAUTIONED AS TO THE FOLLOWING:

15.21 INFORMATION TO USER.

The users manual or instruction manual for an intentional radiator shall caution the user that changes or modifications not expressly approved by the party responsible for compliance could void the user's authority to operate the equipment.

15.27(a) SPECIAL ACCESSORIES.

Equipment marketed to a consumer must be capable of complying with the necessary regulations in the configuration in which the equipment is marketed. Where special accessories, such as shielded cables and/or special connectors are required to enable an unintentional or intentional radiator to comply with the emission limits in this part, the equipment must be marketed with, i.e. shipped and sold with, those special accessories. However, in lieu of shipping or packaging the special accessories with the unintentional or intentional radiator, the responsible party may employ other methods of ensuring that the special accessories are provided to the consumer, without additional charge.

Information detailing any alternative method used to supply the special accessories for a grant of equipment authorization or retained in the verification records, as appropriate. The party responsible for the equipment, as detailed in § 2.909 of this chapter, shall ensure that these special accessories are provided with the equipment. The instruction manual for such devices shall include appropriate instructions on the first page of text concerned with the installation of the device that these special accessories must be used with the device. It is the responsibility of the user to use the needed special accessories supplied with the equipment.

TABLE OF CONTENTS

RULE	DESCRIPTION	PAGE
	Test Report	1
2.1033(c)	General Information Required	2
2.1033(c)(14)	Rule Summary	5
	Standard Test Conditions and Engineering Practices	6
80.365	VHF Radiotelephone Frequencies	7
2.1046(a)	ERP Carrier Power (Radiated)	8
2.1047(a)	Audio Frequency Response	9
2.1047(a)	Audio Low Pass Filter (Voice Input)	12
2.1047(b)	Modulation Limiting	14
2.1049(c)(1)	Emission Masks (Occupied Bandwidth)	16
2.1053(a)	Field Strength of Spurious Radiation	21
2.1055(a)(1)	Frequency Stability (Temperature Variation)	25
2.1055(b)(1)	Frequency Stability (Voltage Variation)	28
80.203(b)	User Controls	29
80.203(c)	Automatic Deactivation (Time-Out Timer)	30
80.225	Requirements for DSC	31
80.959(a)&(b)	Subpart T - G3E Emissions	35
80.961(a)&(b)	Subpart T - G3E Emissions	36
80.1011, 80.1013		
	Subpart U - Bridge-to-Bridge Act	37
2.202(g)	Necessary Bandwidth and Emission Bandwidth	38

PAGE NO. 1 of 38.

Required information per ISO/IEC Guide 25-1990, paragraph 13.2:

- a) TEST REPORT
- b) Laboratory: M. Flom Associates, Inc.
(FCC: 31040/SIT) 3356 N. San Marcos Place, Suite 107
(Canada: IC 2044) Chandler, AZ 85225
- c) Report Number: d0240012
- d) Client: Vertex Standard USA Inc.
10900 Walker Street
Cypress, CA 90630
- e) Identification: GX1255S
FCC ID: K66GX1255S
Description: VHF Marine Mobile
- f) EUT Condition: Not required unless specified in individual tests.
- g) Report Date: April 4, 2002
EUT Received: March 26, 2002
- h, j, k): As indicated in individual tests.
- i) Sampling method: No sampling procedure used.
- l) Uncertainty: In accordance with MFA internal quality manual.
- m) Supervised by: 
Morton Flom, P. Eng.
- n) Results: The results presented in this report relate only to the item tested.
- o) Reproduction: This report must not be reproduced, except in full, without written permission from this laboratory.

PAGE NO. 2 of 38.

LIST OF GENERAL INFORMATION REQUIRED FOR CERTIFICATION

IN ACCORDANCE WITH FCC RULES AND REGULATIONS,
VOLUME II, PART 2 AND TO

2, 15, 80, T, U, R, S

Sub-part 2.1033

(c)(1): NAME AND ADDRESS OF APPLICANT:

Vertex Standard Co., Ltd.
4-8-8 Nakameguro, Meguro-Ku
Tokyo 153-8644 Japan

MANUFACTURER:

Applicant

(c)(2): FCC ID: K66GX1255S

MODEL NO: GX1255S

(c)(3): INSTRUCTION MANUAL(S):

PLEASE SEE ATTACHED EXHIBITS

(c)(4): TYPE OF EMISSION: 16K0G3E, 16K0G2B

(c)(5): FREQUENCY RANGE, MHz: 156 to 162
156.025 to 157.425

(c)(6): POWER RATING, Watts: 1 to 25
x Switchable ___ Variable ___ N/A

FCC GRANT NOTE: CS - Transmitter meets technical requirements only for use at ship stations

(c)(7): MAXIMUM POWER RATING, Watts: 25

PAGE NO. 3 of 38.

Subpart 2.1033 (continued)

(c)(8): VOLTAGES & CURRENTS IN ALL ELEMENTS IN FINAL R. F. STAGE, INCLUDING FINAL TRANSISTOR OR SOLID STATE DEVICE:

COLLECTOR CURRENT, A	=	per manual
COLLECTOR VOLTAGE, Vdc	=	per manual
SUPPLY VOLTAGE, Vdc	=	13.8

(c)(9): TUNE-UP PROCEDURE:

PLEASE SEE ATTACHED EXHIBITS

(c)(10): CIRCUIT DIAGRAM/CIRCUIT DESCRIPTION:

Including description of circuitry & devices provided for determining and stabilizing frequency, for suppression of spurious radiation, for limiting modulation and limiting power.

PLEASE SEE ATTACHED EXHIBITS

(c)(11): LABEL INFORMATION:

PLEASE SEE ATTACHED EXHIBITS

(c)(12): PHOTOGRAPHS:

PLEASE SEE ATTACHED EXHIBITS

(c)(13): DIGITAL MODULATION DESCRIPTION:

<u> </u>	ATTACHED EXHIBITS
<u> x </u>	N/A

(c)(14): TEST AND MEASUREMENT DATA:

FOLLOWS

M. Flom Associates, Inc. is accredited by the American Association for Laboratory Association (A2LA) as shown in the scope below.



THE AMERICAN ASSOCIATION FOR LABORATORY ACCREDITATION

ACCREDITED LABORATORY

A2LA has accredited

M. FLOM ASSOCIATES, INC.
Chandler, AZ

for technical competence in the field of

Electrical (EMC) Testing

The accreditation covers the specific tests and types of tests listed on the agreed scope of accreditation. This laboratory meets the requirements of ISO/IEC 17025 - 1999 "General Requirements for the Competence of Testing and Calibration Laboratories" and any additional program requirements in the identified field of testing. Testing and calibration laboratories that comply with this International Standard also operate in accordance with ISO 9001 or ISO 9002.

Presented this 2nd day of March, 2001.



Peter Almy
President
For the Accreditation Council
Certificate Number 1008.01
Valid to December 31, 2002

For tests or types of tests to which this accreditation applies, please refer to the laboratory's Electrical (EMC) Scope of Accreditation



American Association for Laboratory Accreditation

SCOPE OF ACCREDITATION TO ISO/IEC 17025-1999

M. FLOM ASSOCIATES, INC.
Electronic Testing Laboratory
3356 North San Marcos Place, Suite 107
Chandler, AZ 85223
Morton Flom Phone: 480 926 3100

ELECTRICAL (EMC)

Valid to: December 31, 2002 Certificate Number: 1008-01

In recognition of the successful completion of the A2LA evaluation process, accreditation is granted to this laboratory to perform the following electromagnetic compatibility tests:

Tests	Standard(s)
RF Emissions	FCC Part 15 (Subparts B and C) using ANSI C63.4-1992; CISPR 11; CISPR 13; CISPR 14; CISPR 22; EN 55011; EN 55013; EN 55014; EN 55022; EN 50081-1; EN 50081-2; ICES-003; AS/NZS 1044; AS/NZS 1053; AS/NZS 3548; AS/NZS 4251.1; CNS 13438
Harmonic Currents	EN 61000-3-2
Fluctuation and Flicker	EN 61000-3-3
RF Immunity	EN: 50082-1, 50082-2 (both excluding "Power Frequency Magnetic Field Immunity" and "Voltage Dips, Short Interruptions, and Line Voltage Variations"); AS/NZS 4251.1
Radiated Susceptibility	EN 61000-4-3; ENV 50140; ENV 50204; IEC 1000-4-3; IEC 801-3
EFT	EN 61000-4-4; IEC 1000-4-4; IEC 801-4
Surge	EN 61000-4-5; ENV 50142; IEC 1000-4-5; IEC 801-5
47 CFR (FCC)	2, 21, 22, 23, 24, 74, 80, 87, 90, 95, 97



5301 Buckeystown Pike, Suite 350 • Frederick, MD 21704-8373 • Phone: 301-644 3248 • Fax: 301-662 2974

"This laboratory is accredited by the American Association for Laboratory Accreditation (A2LA) and the results shown in this report have been determined in accordance with the laboratory's terms of accreditation unless stated otherwise in the report."

Should this report contain any data for tests for which we are not accredited, or which have been undertaken by a subcontractor that is not A2LA accredited, such data would not covered by this laboratory's A2LA accreditation.

PAGE NO.

5 of 38.

Sub-part

2.1033(c)(14): TEST AND MEASUREMENT DATA

All tests and measurement data shown were performed in accordance with FCC Rules and Regulations, Volume II; Part 2, Sub-part J, Sections 2.947, 2.1033(c), 2.1041, 2.1046, 2.1047, 2.1079, 2.1051, 2.1053, 2.1055, 2.1057 and the following individual Parts:

- 21 - Domestic Public Fixed Radio Services
- 22 - Public Mobile Services
- 22 Subpart H - Cellular Radiotelephone Service
- 22.901(d) - Alternative technologies and auxiliary services
- 23 - International Fixed Public Radiocommunication services
- 24 - Personal Communications Services
- 74 Subpart H - Low Power Auxiliary Stations
- 80 - Stations in the Maritime Services
- 80 Subpart E - General Technical Standards
- 80 Subpart F - Equipment Authorization for Compulsory Ships
- 80 Subpart K - Private Coast Stations and Marine Utility Stations
- 80 Subpart R
- 80 Subpart S - Compulsory Radiotelephone Installations for Small Passenger Boats
- 80 Subpart T - Radiotelephone Installation Required for Vessels on the Great Lakes
- 80 Subpart U - Radiotelephone Installations Required by the Bridge-to-Bridge Act
- 80 Subpart V - Emergency Position Indicating Radiobeacons (EPIRB'S)
- 80 Subpart W - Global Maritime Distress and Safety System (GMDSS)
- 80 Subpart X - Voluntary Radio Installations
- 87 - Aviation Services
- 90 - Private Land Mobile Radio Services
- 94 - Private Operational-Fixed Microwave Service
- 95 Subpart A - General Mobile Radio Service (GMRS)
- 95 Subpart C - Radio Control (R/C) Radio Service
- 95 Subpart D - Citizens Band (CB) Radio Service
- 95 Subpart E - Family Radio Service
- 95 Subpart F - Interactive Video and Data Service (IVDS)
- 97 - Amateur Radio Service
- 101 - Fixed Microwave Services

PAGE NO.

6 of 38.

STANDARD TEST CONDITIONS and ENGINEERING PRACTICES

Except as noted herein, the following conditions and procedures were observed during the testing:

In accordance with ANSIC63.4-1992/2000 Draft, section 6.1.9, and unless otherwise indicated in the specific measurement results, the ambient temperature of the actual EUT was maintained within the range of 10° to 40°C (50° to 104 °F) unless the particular equipment requirements specify testing over a different temperature range. Also, unless otherwise indicated, the humidity levels were in the range of 10% to 90% relative humidity.

Prior to testing, the EUT was tuned up in accordance with the manufacturer's alignment procedures. All external gain controls were maintained at the position of maximum and/or optimum gain throughout the testing.

Measurement results, unless otherwise noted, are worst case measurements.

PAGE NO.

7 of 38.

VHF RADIOTELEPHONE FREQUENCIES

CH	TX FREQ.	POWER		CH	TX FREQ.	POWER	
		LOW	HIGH			Low	High
1	156.050	X	X	61	156.075	X	X
2				62			
3	156.150	X	X	63	156.175	X	X
4				64	156.225	X	X
5	156.250	X	X	65	156.275	X	X
6	156.300	X	X	66	156.325	X	X
7	156.350	X	X	67	156.375		X
8	156.400	X	X	68	156.425	X	X
9	156.450	X	X	69	156.475	X	X
10	156.500	X	X	70	156.525		
11	156.550	X	X	71	156.575	X	X
12	156.600	X	X	72	156.625	X	X
13	156.650		X	73	156.675	X	X
14	156.700	X	X	74	156.725	X	X
15				75			
16	156.800	X	X	76			
17	156.850		X	77	156.875		X
18	156.900	X	X	78	156.925	X	X
19	156.950	X	X	79	156.975	X	X
20	157.000	X	X	80	157.025	X	X
21	157.050	X	X	81	157.075	X	X
22	157.100	X	X	82	157.125	X	X
23	157.150	X	X	83	157.175	X	X
24	157.200	X	X	84	157.225	X	X
25	157.250	X	X	85	157.275	X	X
26	157.300	X	X	86	157.325	X	X
27	157.350	X	X	87	157.375	X	X
28	157.400	X	X	88	157.425	X	X

PAGE NO. 8 of 38.

NAME OF TEST: ERP Carrier Power (Radiated)

SPECIFICATION: TIA/EIA 603A (Substitution Method)

2.2.17.1 Definition: The average radiated power of a licensed device is the equivalent power required, when delivered to a half-wave dipole or horn antenna, to produce at a distant point the same average received power as produced by the licensed device.

2.2.17.2 Method of Measurement:

a) Connect the equipment as illustrated. Place the transmitter to be tested on the turntable in the standard test site.

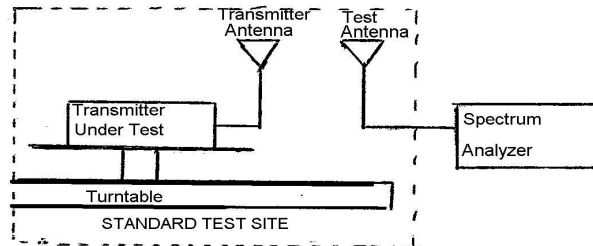

b) Raise and lower the test antenna from 1m to 6 m with the transmitter facing the antenna and record the highest received signal in dB as LVL.

c) Repeat step b) for seven additional readings at 45° interval positions of the turntable.

d) Replace the transmitter under test with a half-wave or horn vertically polarized antenna. The center of the antenna should be at the same location as the transmitter under test. Connect the antenna to a signal generator with a known output power and record the path loss in dB or LOSS.

e) Calculate the average radiated output power from the readings in step c) and d) by the following:

$$\text{average radiated power} = 10 \log_{10} \Sigma 10(\text{LVL} - \text{LOSS})/10 \text{ (dBm)}$$

<u>RESULTS</u>		
156.8 MHZ		
	LVL, dbm	Path Loss, db
0°	42.8	0.1
45°	41.9	0.1
90°	40.1	0.1
135°	40.8	0.1
180°	41.3	0.1
225°	41.1	0.1
270°	41.4	0.1
315°	41.8	0.1
<hr/>		
156.8 MHZ		
Av. Radiated Power:	41.5 dbm	
Peak Radiated Power:	44.9 dbm	

PAGE NO. 9 of 38.
NAME OF TEST: Audio Frequency Response
SPECIFICATION: 47 CFR 2.1047(a)
GUIDE: ANSI/TIA/EIA-603-1992, Paragraph 2.2.6
TEST EQUIPMENT: As per attached page

MEASUREMENT PROCEDURE

1. The EUT and test equipment were set up as shown on the following page.
2. The audio signal generator was connected to the audio input circuit/microphone of the EUT.
3. The audio signal input was adjusted to obtain 50% modulation at 1 kHz, and this point was taken as the 0 dB reference level.
4. With input levels held constant and below limiting at all frequencies, the audio signal generator was varied from 100 Hz to 50 kHz.
5. The response in dB relative to 1 kHz was then measured, using the HP 8901A Modulation Analyzer.
6. MEASUREMENT RESULTS: ATTACHED

TRANSMITTER TEST SET-UP

- TEST A. MODULATION CAPABILITY/DISTORTION
- TEST B. AUDIO FREQUENCY RESPONSE
- TEST C. HUM AND NOISE LEVEL
- TEST D. RESPONSE OF LOW PASS FILTER
- TEST E. MODULATION LIMITING

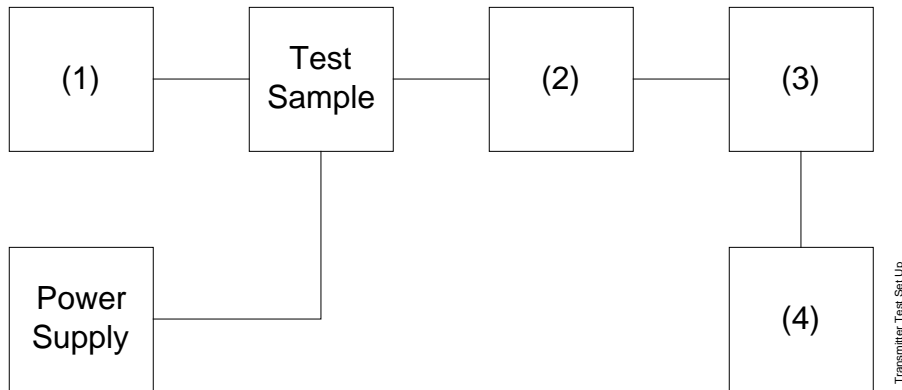

Asset Description (as applicable)	s/n
(1) <u>AUDIO OSCILLATOR</u>	
i00010 HP 204D	1105A04683
i00017 HP 8903A	2216A01753
i00118 HP 33120A	US36002064
(2) <u>COAXIAL ATTENUATOR</u>	
i00122 NARDA 766-10	7802
i00123 NARDA 766-10	7802A
i00113 SIERRA 661A-3D	1059
i00069 BIRD 8329 (30 dB)	10066
(3) <u>MODULATION ANALYZER</u>	
i00020 HP 8901A	2105A01087
(4) <u>AUDIO ANALYZER</u>	
i00017 HP 8903A	2216A01753

PAGE NO. 11 of 38.

NAME OF TEST: Audio Frequency Response
 g0230310: 2002-Mar-28 Thu 11:28:00
 STATE: 0:General

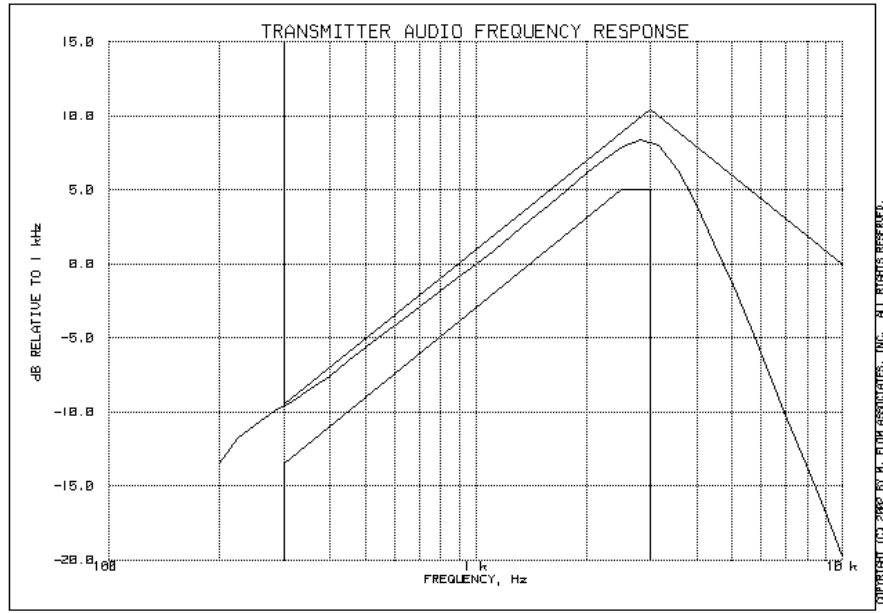

Additional points:

FREQUENCY, Hz	LEVEL, dB
300	-9.52
20000	-33.86
30000	-33.32
50000	-33.28

SUPERVISED BY:

Morton Flom, P. Eng.

PAGE NO. 12 of 38.
NAME OF TEST: Audio Low Pass Filter (Voice Input)
SPECIFICATION: 47 CFR 2.1047(a)
GUIDE: ANSI/TIA/EIA-603-1992, Paragraph 2.2.15
TEST EQUIPMENT: As per previous page

MEASUREMENT PROCEDURE

1. The EUT and test equipment were set up such that the audio input was connected at the input to the modulation limiter, and the modulated stage.
2. The audio output was connected at the output to the modulated stage.
3. MEASUREMENT RESULTS: ATTACHED

PAGE NO. 13 of 38.

NAME OF TEST: Audio Low Pass Filter (Voice Input)
g0230311: 2002-Mar-28 Thu 11:37:00
STATE: 0:General

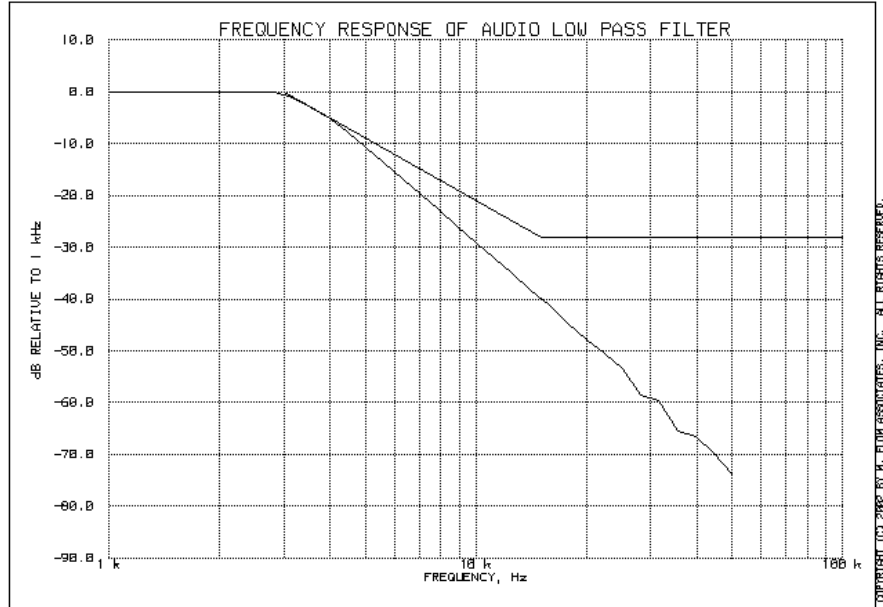

SUPERVISED BY:

Morton Flom, P. Eng.

PAGE NO. 14 of 38.
NAME OF TEST: Modulation Limiting
SPECIFICATION: 47 CFR 2.1047(b), 80.211, 80.213
GUIDE: ANSI/TIA/EIA-603-1992, Paragraph 2.2.3
TEST EQUIPMENT: As per previous page

MEASUREMENT PROCEDURE

1. The signal generator was connected to the input of the EUT as for "Frequency Response of the Modulating Circuit."
2. The modulation response was measured for each of three frequencies (one of which was the frequency of maximum response), and the input voltage was varied and was observed on an HP 8901A Modulation Analyzer.
3. The input level was varied from 30% modulation (± 1.5 kHz deviation) to at least 20 dB higher than the saturation point.
4. Measurements were performed for both negative and positive modulation and the respective results were recorded.
5. MEASUREMENT RESULTS: ATTACHED

PAGE NO. 15 of 38.

NAME OF TEST: Modulation Limiting
g0230312: 2002-Mar-28 Thu 11:41:00
STATE: 0:General

Positive Peaks:

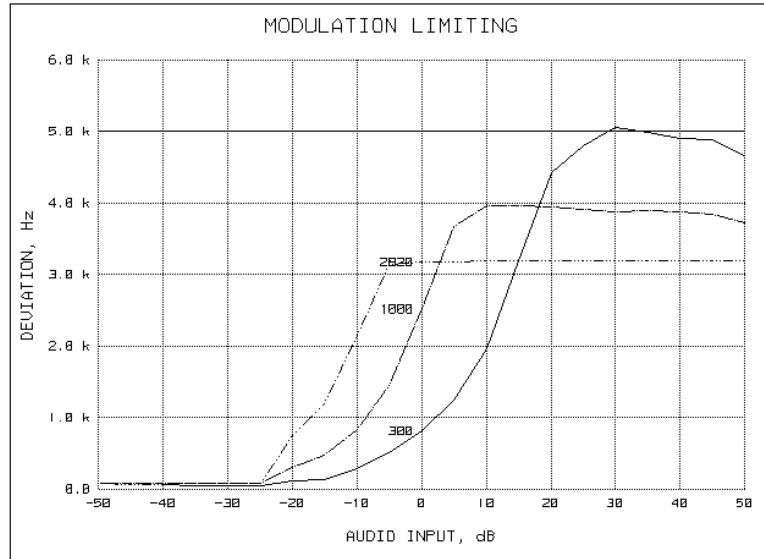

Negative Peaks:

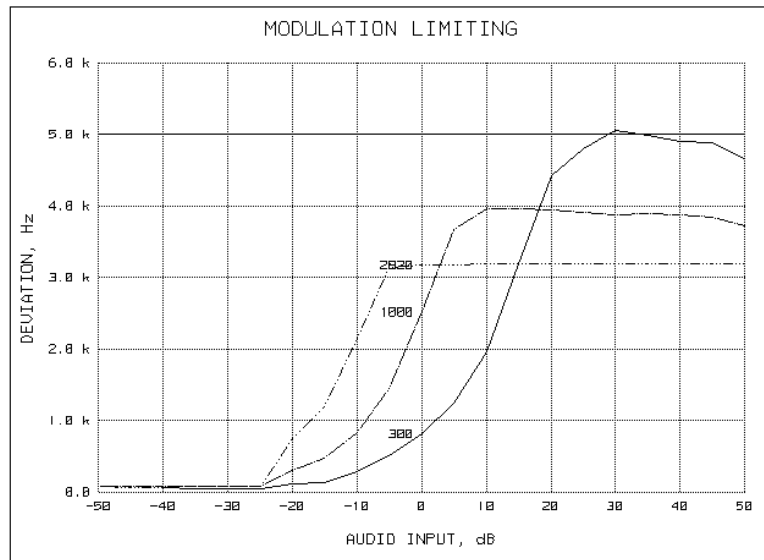

SUPERVISED BY:

Morton Flom, P. Eng.

PAGE NO. 16 of 38.
NAME OF TEST: Emission Masks (Occupied Bandwidth)
SPECIFICATION: 47 CFR 2.1049(c)(1)
GUIDE: ANSI/TIA/EIA-603-1992, Paragraph 2.2.11
TEST EQUIPMENT: As per previous page

MEASUREMENT PROCEDURE

1. The EUT and test equipment were set up as shown on the following page, with the Spectrum Analyzer connected.
2. For EUTs supporting audio modulation, the audio signal generator was adjusted to the frequency of maximum response and with output level set for ± 2.5 kHz deviation (or 50% modulation). With level constant, the signal level was increased 16 dB.
3. For EUTs supporting digital modulation, the digital modulation mode was operated to its maximum extent.
4. The Occupied Bandwidth was measured with the Spectrum Analyzer controls set as shown on the test results.
5. MEASUREMENT RESULTS: ATTACHED

PAGE NO. 17 of 38.

NAME OF TEST: Emission Masks (Occupied Bandwidth)
g0230345: 2002-Mar-28 Thu 12:22:00
STATE: 1:Low Power

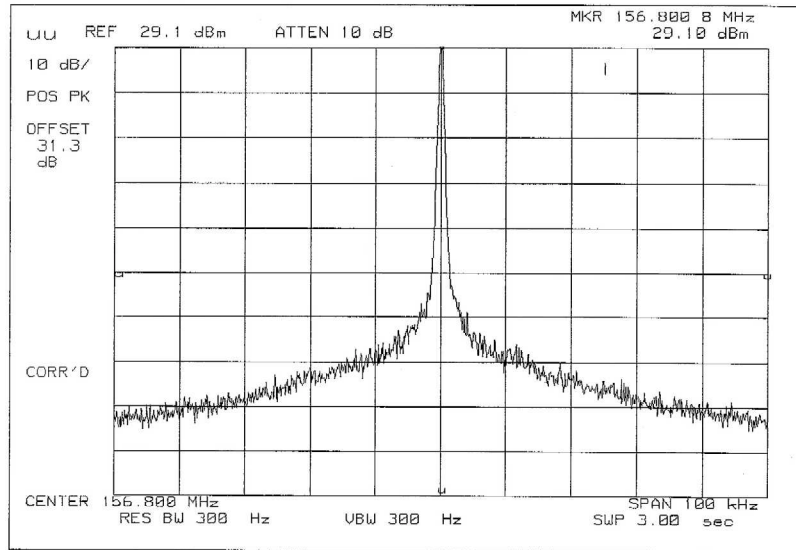

POWER: LOW
MODULATION: NONE

SUPERVISED BY:

Morton Flom, P. Eng.

PAGE NO. 18 of 38.

NAME OF TEST: Emission Masks (Occupied Bandwidth)
g0230347: 2002-Mar-28 Thu 12:25:00
STATE: 1:Low Power

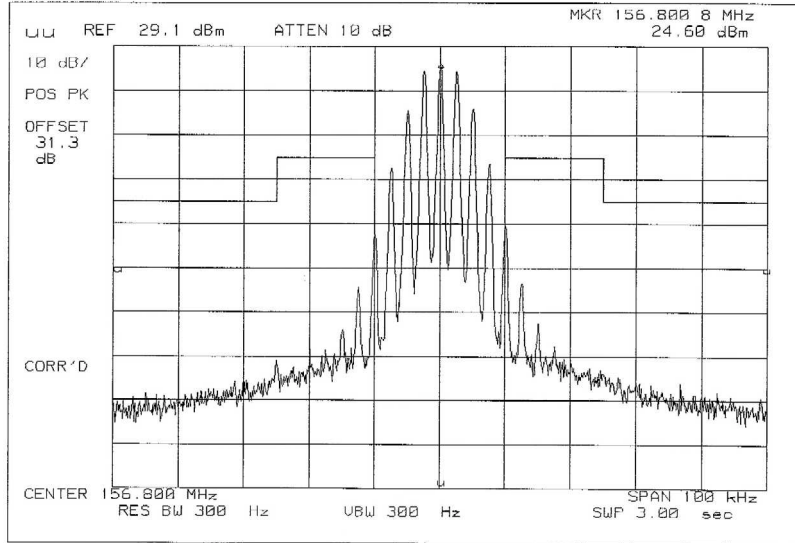

POWER:
MODULATION:

LOW
VOICE: 2500 Hz SINE WAVE
MASK: B, VHF/UHF 25kHz,
w/LPF

SUPERVISED BY:

Morton Flom P. Eng.
Morton Flom, P. Eng.

PAGE NO. 20 of 38.

NAME OF TEST: Emission Masks (Occupied Bandwidth)
g0230346: 2002-Mar-28 Thu 12:24:00
STATE: 2:High Power

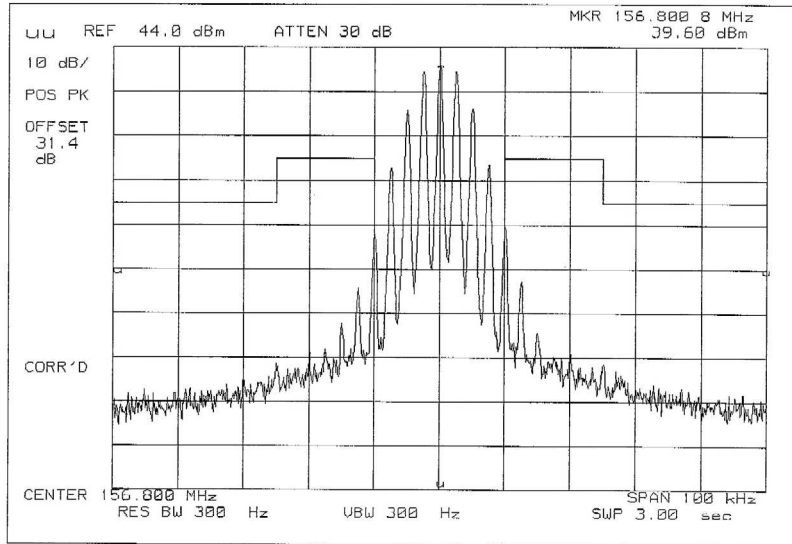

POWER:	HIGH
MODULATION:	VOICE: 2500 Hz SINE WAVE
	MASK: B, VHF/UHF 25kHz,
	w/LPF

SUPERVISED BY:

Morton Flom P. Eng.
Morton Flom, P. Eng.

PAGE NO. 21 of 38.

NAME OF TEST: Field Strength of Spurious Radiation

SPECIFICATION: 47 CFR 2.1053(a)

GUIDE: ANSI/TIA/EIA-603-1992/2001, Paragraph 1.2.12 and Table 16, 47 CFR 22.917

MEASUREMENT PROCEDURE

1.2.12.1 Definition: Radiated spurious emissions are emissions from the equipment when transmitting into a non-radiating load on a frequency or frequencies which are outside an occupied band sufficient to ensure transmission of information of required quality for the class of communications desired.

1.2.12.2 Method of Measurement

- A) Connect the equipment as illustrated
- B) Adjust the spectrum analyzer for the following settings:
- 1) Resolution Bandwidth 10 kHz (<1 GHz), 1 MHz (> 1GHz).
 - 2) Video Bandwidth \geq 3 times Resolution Bandwidth, or 30 kHz (22.917)
 - 3) Sweep Speed \leq 2000 Hz/second
 - 4) Detector Mode = Mean or Average Power
- C) Place the transmitter to be tested on the turntable in the standard test site. The transmitter is transmitting into a non-radiating load which is placed on the turntable. The RF cable to this load should be of minimum length.

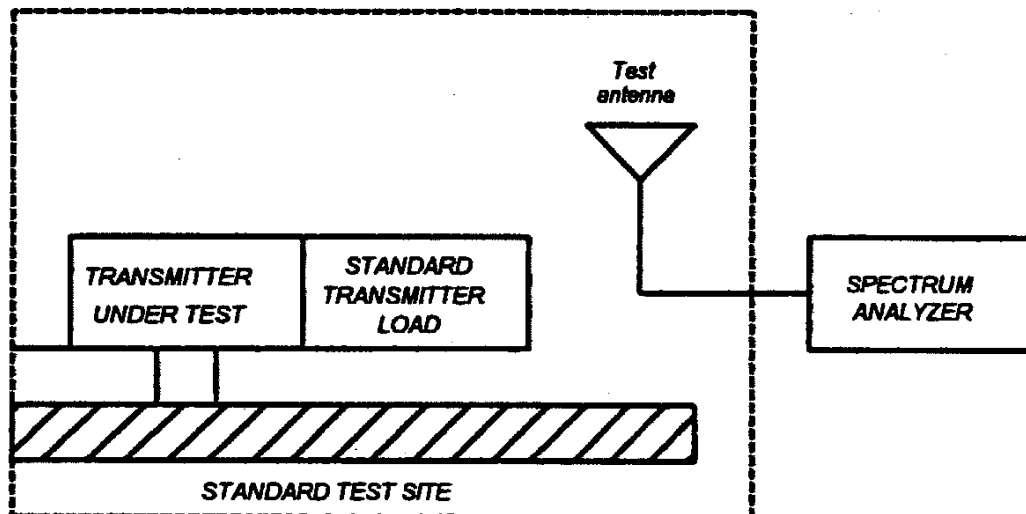

PAGE NO. 22 of 38.

NAME OF TEST: Field Strength of Spurious Radiation (Cont.)

- D) For each spurious measurement the test antenna should be adjusted to the correct length for the frequency involved. This length may be determined from a calibration ruler supplied with the equipment. Measurements shall be made from the lowest radio frequency generated in the equipment to the tenth harmonic of the carrier, except for the region close to the carrier equal to \pm the test bandwidth (see section 1.3.4.4).
- E) For each spurious frequency, raise and lower the test antenna from 1 m to 4 m to obtain a maximum reading on the spectrum analyzer with the test antenna at horizontal polarity. Repeat this procedure to obtain the highest possible reading. Record this maximum reading.
- F) Repeat step E) for each spurious frequency with the test antenna polarized vertically.

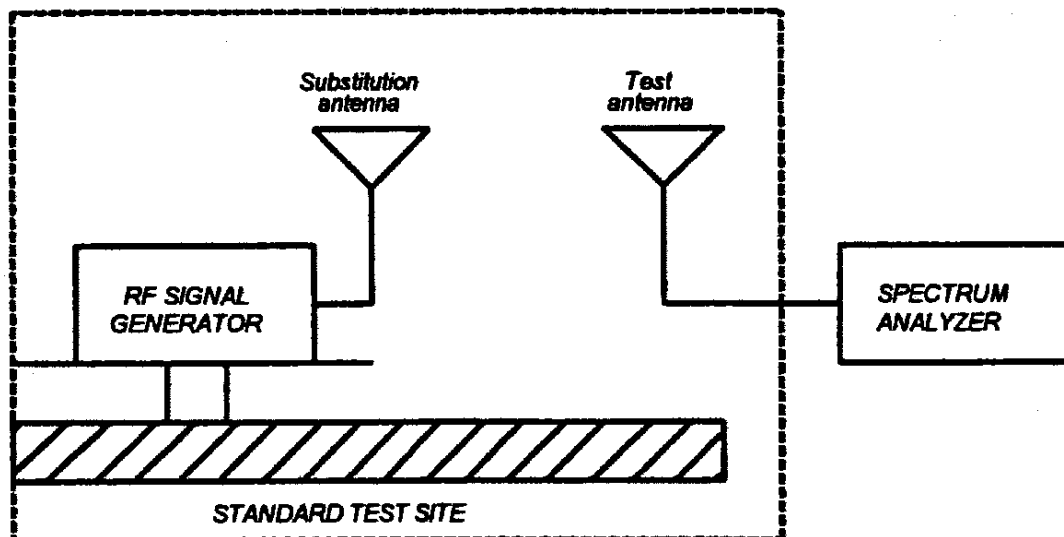

- G) Reconnect the equipment as illustrated.
- H) Keep the spectrum analyzer adjusted as in step B).
- I) Remove the transmitter and replace it with a substitution antenna (the antenna should be half-wavelength for each frequency involved). The center of the substitution antenna should be approximately at the same location as the center of the transmitter. At lower frequencies, where the substitution antenna is very long, this will be impossible to achieve when the antenna is polarized vertically. In such case the lower end of the antenna should be 0.3 m above the ground.

PAGE NO. 23 of 38.

NAME OF TEST: Field Strength of Spurious Radiation (Cont.)

- J) Feed the substitution antenna at the transmitter end with a signal generator connected to the antenna by means of a non-radiating cable. With the antennas at both ends horizontally polarized and with the signal generator tuned to a particular spurious frequency, raise and lower the test antenna to obtain a maximum reading at the spectrum analyzer. Adjust the level of the signal generator output until the previously recorded maximum reading for this set of conditions is obtained. This should be done carefully repeating the adjustment of the test antenna and generator output.
- K) Repeat step J) with both antennas vertically polarized for each spurious frequency.
- L) Calculate power in dBm into a reference ideal half-wave dipole antenna by reducing the readings obtained in steps J) and K) by the power loss in the cable between the generator and the antenna and further corrected for the gain of the substitution antenna used relative to an ideal half-wave dipole antenna.
- M) The levels recorded in step L) are absolute levels of radiated spurious emissions in dBm. The radiated spurious emissions in dB can be calculated by the following:

$$\text{Radiated spurious emissions dB} = 10\log_{10}(\text{TX power in watts}/0.001) - \text{the levels in step l)}$$

NOTE: It is permissible that other antennas provided can be referenced to a dipole.

Test Equipment:

Asset Description (as applicable)	s/n	Cycle	Last Cal
<u>TRANSDUCER</u>			
i00088 EMCO 3109-B 25MHz-300MHz	2336	12 mo.	Sep-01
i00065 EMCO 3301-B Active Monopole	2635	12 mo.	Sep-01
i00089 Aprel 2001 200MHZ-1GHz	001500	12 mo.	Sep-01
i00103 EMCO 3115 1GHz-18GHz	9208-3925	12 mo.	Sep-01
<u>AMPLIFIER</u>			
i00028 HP 8449A	2749A00121	12 mo.	Mar-02
<u>SPECTRUM ANALYZER</u>			
i00029 HP 8563E	3213A00104	12 mo.	Jan-02
i00033 HP 85462A	3625A00357	12 mo.	Jan-02
i00048 HP 8566B	2511AD1467	6 mo.	Jan-02

Per ANSI C63.4-1992/2000 Draft, 10.1.4

PAGE NO. 24 of 38.

NAME OF TEST: Field Strength of Spurious Radiation
 g0230343: 2002-Mar-28 Thu 13:54:00
 STATE: 2:High Power

FREQUENCY TUNED, MHz	FREQUENCY EMISSION, MHz	ERP, dBm	ERP, dbc
156.800000	313.596667	-32	≤-61.3
156.800000	470.400000	-25.2	≤-61.3
156.800000	627.198333	-17.3	≤-61.3
156.800000	783.991667	-27.3	≤-61.3
0.000000	940.798367	-27	≤-61.3
156.800000	1095.325000	-32.2	≤-61.3
156.800000	1251.797500	-25.6	≤-61.3
0.000000	1411.195034	-38.9	≤-61.3
0.000000	1567.995034	-40.8	≤-61.3

PAGE NO. 25 of 38.
NAME OF TEST: Frequency Stability (Temperature Variation)
SPECIFICATION: 47 CFR 2.1055(a)(1)
GUIDE: ANSI/TIA/EIA-603-1992, Paragraph 2.2.2
TEST CONDITIONS: As Indicated
TEST EQUIPMENT: As per previous page

MEASUREMENT PROCEDURE

1. The EUT and test equipment were set up as shown on the following page.
2. With all power removed, the temperature was decreased to -30°C and permitted to stabilize for three hours. Power was applied and the maximum change in frequency was noted within one minute.
3. With power OFF, the temperature was raised in 10°C steps. The sample was permitted to stabilize at each step for at least one-half hour. Power was applied and the maximum frequency change was noted within one minute.
4. The temperature tests were performed for the worst case.
5. MEASUREMENT RESULTS: ATTACHED

TRANSMITTER TEST SET-UP

- TEST A. OPERATIONAL STABILITY
- TEST B. CARRIER FREQUENCY STABILITY
- TEST C. OPERATIONAL PERFORMANCE STABILITY
- TEST D. HUMIDITY
- TEST E. VIBRATION
- TEST F. ENVIRONMENTAL TEMPERATURE
- TEST G. FREQUENCY STABILITY: TEMPERATURE VARIATION
- TEST H. FREQUENCY STABILITY: VOLTAGE VARIATION

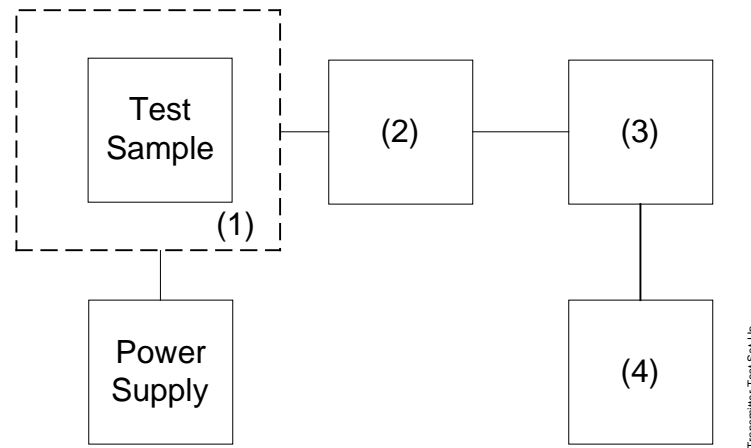

Asset Description (as applicable)	s/n
<u>(1) TEMPERATURE, HUMIDITY, VIBRATION</u>	
i00027 TennEy Temp. Chamber	9083-765-234
i00 Weber Humidity Chamber	
i00 L.A.B. RVH 18-100	
<u>(2) COAXIAL ATTENUATOR</u>	
i00122 NARDA 766-10	7802
i00123 NARDA 766-10	7802A
i00113 SIERRA 661A-3D	1059
i00069 BIRD 8329 (30 dB)	10066
<u>(3) R.F. POWER</u>	
i00014 HP 435A POWER METER	1733A05839
i00039 HP 436A POWER METER	2709A26776
i00020 HP 8901A POWER MODE	2105A01087
<u>(4) FREQUENCY COUNTER</u>	
i00042 HP 5383A	1628A00959
i00019 HP 5334B	2704A00347
i00020 HP 8901A	2105A01087

PAGE NO.

27 of 38.

NAME OF TEST:

Frequency Stability (Temperature Variation)

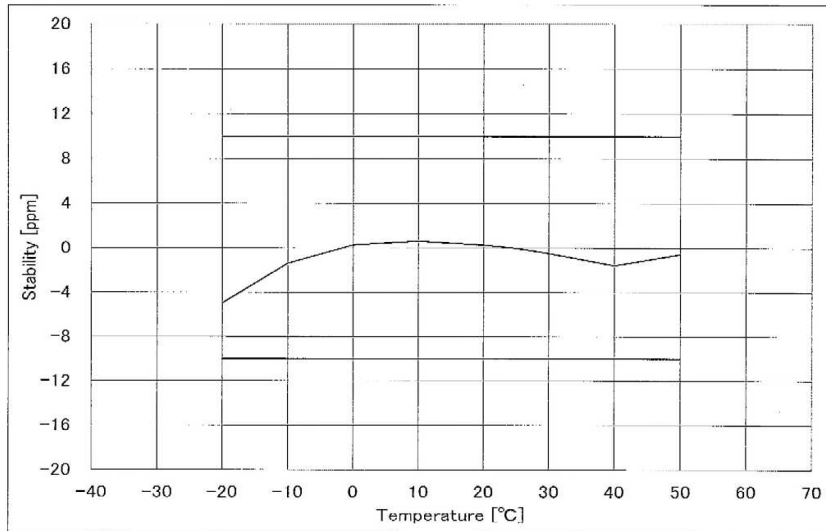

PAGE NO. 28 of 38.
NAME OF TEST: Frequency Stability (Voltage Variation)
SPECIFICATION: 47 CFR 2.1055(d)(1)
GUIDE: ANSI/TIA/EIA-603-1992, Paragraph 2.2.2
TEST EQUIPMENT: As per previous page

MEASUREMENT PROCEDURE

1. The EUT was placed in a temperature chamber at 25±5°C and connected as for "Frequency Stability - Temperature Variation" test.
2. The power supply voltage to the EUT was varied from 85% to 115% of the nominal value measured at the input to the EUT.
3. The variation in frequency was measured for the worst case.

RESULTS: Frequency Stability (Voltage Variation)

LIMIT, ppm = 0.0
LIMIT, Hz = 0

<u>% of STV</u>	<u>Voltage</u>	<u>Frequency, MHz</u>	<u>Change, Hz</u>	<u>Change, ppm</u>
85	11.73	156.800114	114	0.73
100	13.80	156.800114	114	0.73
115	15.87	156.800114	114	0.73

PAGE NO. 29 of 38.
NAME OF TEST: User Controls
SPECIFICATION: 47 CFR 80.203(b)

STATEMENT

The external controls of the maritime station transmitter capable of operation in the 156-162 MHz band only provides for selection of maritime channels for which the maritime station is authorized. This transmitter is not capable of being programmed by station operators using external controls to transmit on channels other than those programmed by the manufacturer, service or maintenance personal.

The EUT fully complies with the requirements of 47 CFR 80.203 (b).

PAGE NO. 30 of 38.
NAME OF TEST: Automatic Deactivation (Time-Out Timer)
SPECIFICATION: 47 CFR 80.203(c)

(c) All VHF ship station transmitters that are either manufactured in or imported into the United States, on or after August 1, 1993, or are installed on or after August 1, 1994, must be equipped with an automatic timing device that deactivates the transmitter and reverts the transmitter to the receive mode after an uninterrupted transmission period of five minutes, plus or minus 10 per cent. Additionally, such transmitters must have a device that indicates when the automatic timer has deactivated the transmitter. VHF ship station transmitters initially installed before August 1, 1994, are authorized for use indefinitely at the same maritime station. VHF handheld, portable transmitters are not required to comply with the requirements in paragraph © of this section except when used as described in 80.141.

THE TRANSMITTER MEETS THESE REQUIREMENTS

SUPERVISED BY:



Morton Flom, P. Eng.

PAGE NO. 31 of 38.
NAME OF TEST: Requirements for DSC
SPECIFICATION: 47 CFR 80.225

This section specifies the requirements for voluntary digital selective calling (DSC) equipment and selective calling equipment installed in ship and coast stations. Reference to any CCIR Recommendation in this section is to the most recent CCIR approved Recommendation that does not prevent the use of existing equipment. DSC equipment voluntarily installed in coast or ship stations must meet either the requirements of CCIR Recommendation 493 (including only equipment classes A, B, D, and E) or RTCM Paper 56-5/SC101-STD. DSC equipment must not be used with the sensors referred to in Sec. 80.179(e)(2). DSC equipment used on compulsorily fitted ships must meet the requirements contained in subpart W for GMDSS.

- (b) Manufacturers of Class C DSC equipment to be used on United States vessels must affix a clearly discernible permanent plate or label visible from the operating controls containing the following:

Warning. This equipment is designed to generate digital maritime distress and safety signals to facilitate search and rescue. To be effective as a safety device, this equipment must be used only within communication range of a shore-based VHF marine channel 70 distress and safety watch system. The range of the signal may vary but under normal conditions should be approximately 20 nautical miles.

- (c) Selective calling equipment, other than that designed in accordance with paragraph (a) of this section, is authorized as follows:
- (1) Equipment used in conjunction with the Automated Maritime Telecommunications System (AMTS) in the band 216-220 MHz,
 - (2) Equipment used to perform a selective calling function during narrow-band direct-printing (NB-DP) operations in accordance with CCIR Recommendation 476 or 625, and
 - (3) Equipment functioning under the provisions of Sec. 80.207(a) includes the brief use of radiotelegraphy, including keying only the modulating audio frequency, tone signals, and other signaling devices to establish or maintain communications provided that:
 - (i) These signaling techniques are not used on frequencies designated for general purpose digital selective calling (DSC) and distress and safety DSC calling as listed in Sec. 80.359;
 - (ii) The authorized radiotelephone emission bandwidth is not exceeded;
 - (iii) Documentation of selective calling protocols must be available to the general public; and,
 - (iv) Harmful interference is not caused to stations operating in accordance with the International Radio Regulations.

NAME OF TEST: Emission Masks (Occupied Bandwidth)

STATE: 2 : Low Power

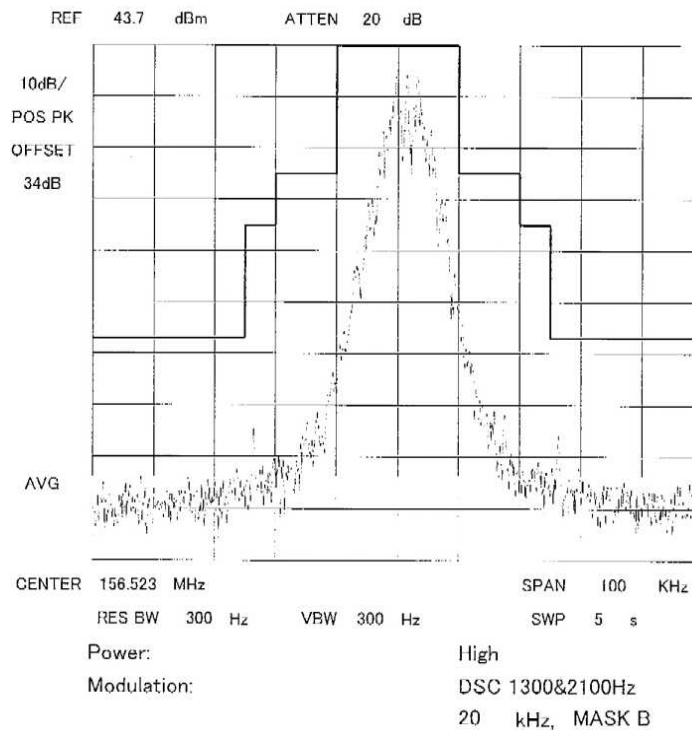
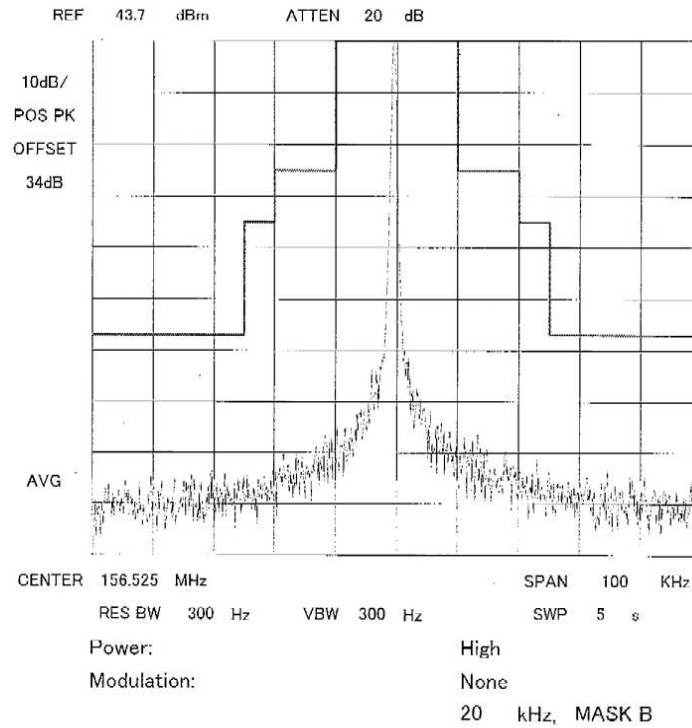

NAME OF TEST: Emission Masks (Occupied Bandwidth)

STATE: 2 : Low Power

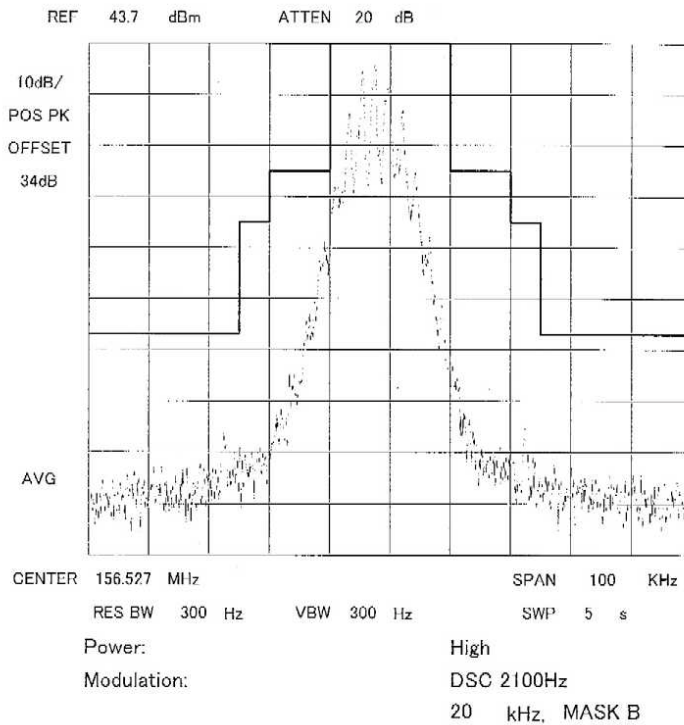
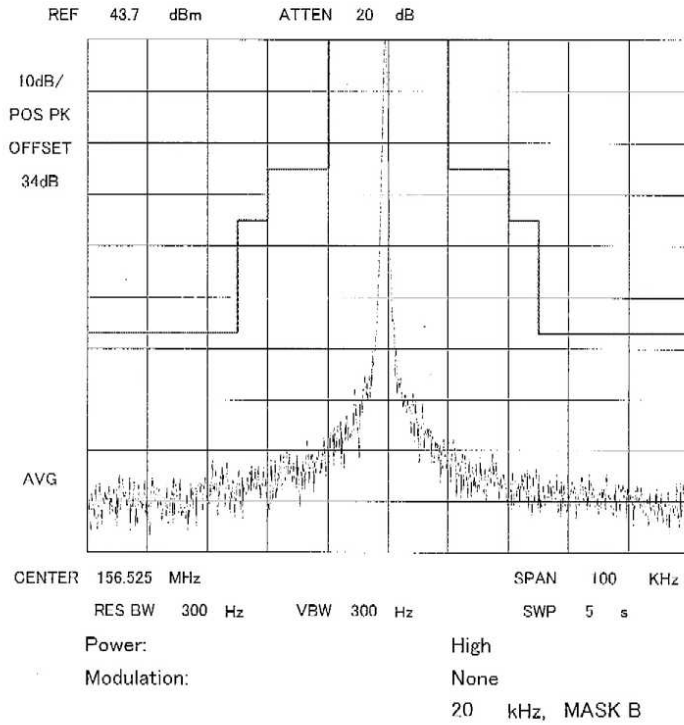

NAME OF TEST: Emission Masks (Occupied Bandwidth)

STATE: 1 : High Power

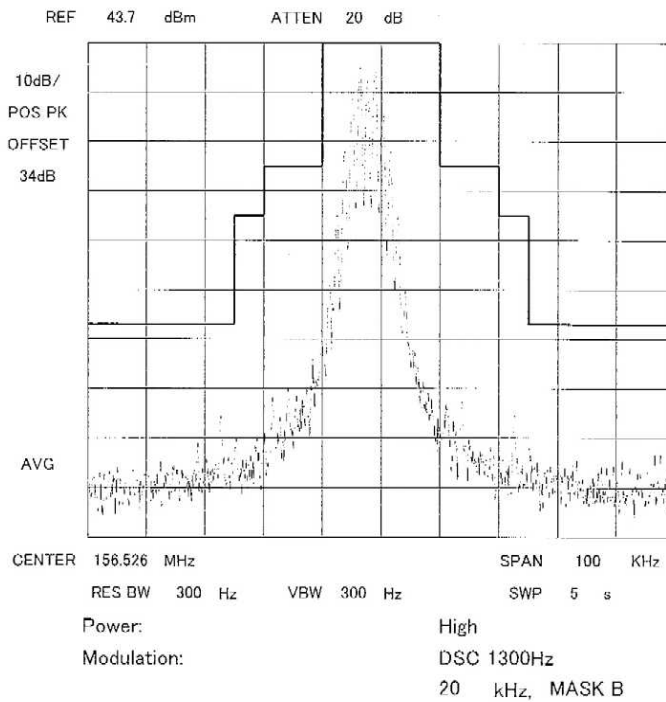
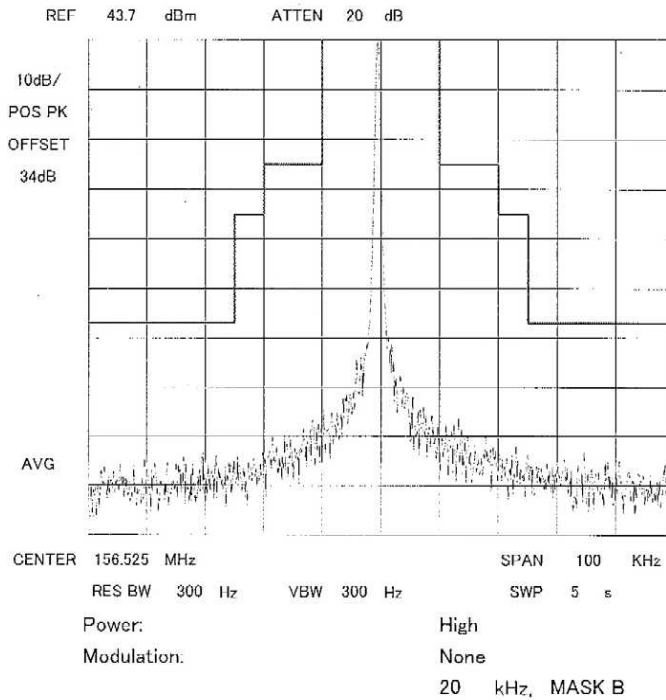

PAGE NO. 35 of 38.
NAME OF TEST: Subpart T - G3E Emissions
SPECIFICATION: 47 CFR 80.956(a) & (b)

MEASUREMENT PROCEDURE

Each VHF R/T installation must be capable of transmitting and receiving G3E emissions.

MEASUREMENT RESULTS

NOMINAL, MHz	CHANNEL	R. F. POWER, WATTS	
		LO	HI
156.300	06	1	25
156.550	11	1	25
156.600	12	1	25
156.650	13* Mobile Only	1	**1/25
156.700	14	1	25
156.750	15	1	25
156.800	16	1	25
156.850	17* Mobile Only	1	**1/25
156.875	67* Mobile Only	1	**1/25

*Automatic switching to low power.

**High power with manual over-ride, see attached manual.

THE TRANSMITTER AND RECEIVER MEET THESE REQUIREMENTS.

SUPERVISED BY:

Morton Flom, P. Eng.

PAGE NO. 36 of 38.
NAME OF TEST: Subpart T - G3E Emissions
SPECIFICATION: 47 CFR 80.961(a) & (b)

MEASUREMENT RESULTS

The receiver is capable of reception of G3E emissions on the required frequencies.

The sensitivity of the receiver at 20 dB SINAD is better than:

SENSITIVITY, dBm = -112.45
SENSITIVITY, μ V = 0.533

SUPERVISED BY:

Morton Flom, P. Eng.

PAGE NO. 37 of 38.
NAME OF TEST: Subpart U - Bridge-to-Bridge Act
SPECIFICATION: 47 CFR 80.1011, 80.1013

RESULTS

80.1011 Transmitter.

The transmitter is capable of G3E emissions on the navigational frequency 156.650 MHz (Channel 13) and the Coast Guard liaison frequency 157.100 MHz (Channel 22). Additionally the transmitter is capable of transmission of G3E emissions on the navigational frequency of 156.375 MHz (Channel 67) while transmitting in any of the applicable waters.

80.1013 Receiver.

The receiver is capable of reception of G3E emissions on the navigational frequency 156.650 MHz (Channel 13) and the Coast Guard liaison frequency 157.100 MHz (Channel 22A). Additionally the receiver is capable of reception of G3E emissions on the navigational frequency of 156.375 MHz (Channel 67) while receiving in any of the applicable waters.

SUPERVISED BY:



Morton Flom, P. Eng.

PAGE NO. 38 of 38.
NAME OF TEST: Necessary Bandwidth and Emission Bandwidth
SPECIFICATION: 47 CFR 2.202(g)

MODULATION = 16K0G3E

NECESSARY BANDWIDTH CALCULATION:

MAXIMUM MODULATION (M), kHz = 3
 MAXIMUM DEVIATION (D), kHz = 5
 CONSTANT FACTOR (K) = 1
 NECESSARY BANDWIDTH (B_N), kHz = (2xM)+(2xDxK)
 = 16.0

MODULATION = 16K0G2B

NECESSARY BANDWIDTH CALCULATION:

MAXIMUM MODULATION (M), kHz = 3
 MAXIMUM DEVIATION (D), kHz = 5
 CONSTANT FACTOR (K) = 1
 NECESSARY BANDWIDTH (B_N), kHz = (2xM)+(2xDxK)
 = 16.0

SUPERVISED BY:
END OF TEST REPORT

Morton Flom, P. Eng.

TESTIMONIAL
AND
STATEMENT OF CERTIFICATION

THIS IS TO CERTIFY THAT:

THAT the application was prepared either by, or under the direct supervision of, the undersigned.

THAT the technical data supplied with the application was taken under my direction and supervision.

THAT the data was obtained on representative units, randomly selected.

THAT, to the best of my knowledge and belief, the facts set forth in the application and accompanying technical data are true and correct.

CERTIFYING ENGINEER:

A handwritten signature in black ink that reads "Morton Flom P. Eng." with a horizontal line underneath the name.

Morton Flom, P. Eng.