

Owner's Manual

MATRIX NMEA2000 GPS

GX2410GPS

- International ITU-R M.493-16 Class D DSC (Digital Selective Calling)
- Integrated dual channel AIS (Automatic Identification System) receiver
- AIS/AIS SART target display: MMSI, Call Sign, Ship Name, BRG, DST, SOG and COG
- NMEA 2000 and NMEA0183 Compatible
- Integrated 66 Channel Internal GPS receiver
- Contact Class A or B AIS Ship with DSC
- Programmable CPA or TCPA collision avoidance alarms
- Submersible IPX8 (1.5 meter for 30 minutes)
- 80dB Commercial grade receiver
- DSC position request and report functions
- GM (Group Monitor) using DSC Group Position Calling
- Navigation (LAT/LON, SOG and COG) information shown on display
- MOB (Man Over-Board) Operation
- Versatile user-programmable scanning, priority scan and Dual/Triple Watch
- Integrated 32 Code Voice Scrambler and 4 Code Voice Scrambler
- 30 Watt PA/Loud Hailer with preprogrammed fog signals and listen back
- Noise canceling for both transmit and receive audio
- Second Station Remote Microphone*
- Intercom Feature between Radio and Second Station Remote Microphone*

*(Optional SSM-70H (RAM4) or SSM-72H (RAM4X) required)



STANDARD HORIZON

Nothing takes to water like Standard Horizon

TABLE OF CONTENTS

QUICK REFERENCE	2	9.11.1 Programming	36
1 GENERAL INFORMATION	3	9.11.2 Operation	36
2 PACKING LIST	4	9.11.3 Deletion	37
3 OPTIONAL ACCESSORIES	4	9.12 MOB OPERATION	37
4 ONLINE WARRANTY REGISTRATION	4	9.13 PA/FOG OPERATION	38
5 Safety Precautions (Be Sure to Read)	5	9.13.1 Operating the PA HAIL mode	38
6 GETTING STARTED	7	9.13.2 Operating the FOG HORN mode	39
6.1 ABOUT VHF RADIO	7	9.13.3 Fog Signal Timing Chart	39
6.2 SELECTING AN ANTENNA	7	9.14 INTERCOM OPERATION	40
6.3 COAXIAL CABLE	7	9.14.1 Communication	40
6.4 DISTRESS AND HAILING (CHANNEL 16)	8	9.14.2 Calling	41
6.5 CALLING ANOTHER VESSEL (CHANNEL 16 OR 9)	9	9.15 INTERCOM OPERATION	41
6.6 WHAT IS THE RANGE FOR AIS RECEIVERS?	10	9.15.1 Communication	41
6.7 Accuracy of COG	10	9.15.2 Calling	42
7 CONTROLS AND INDICATORS	11	9.16 VOICE SCRAMBLER	42
7.1 FRONT PANEL	11	9.17 DEMO MODE	42
7.2 MICROPHONE	13	10 GPS OPERATION	44
7.3 REAR PANEL	14	10.1 DISPLAYING POSITION INFORMATION	44
8 INSTALLATION	16	10.1.1 GPS Information Numerical Display	44
8.1 SAFETY / WARNING INFORMATION	16	10.1.2 GPS Information Compass Display	44
8.2 LOCATION	16	10.2 CHECKING GPS STATUS	44
8.3 MOUNTING THE RADIO	16	10.3 GPS LOGGER OPERATION	45
8.3.1 Supplied Mounting Bracket	16	11 DIGITAL SELECTIVE CALLING (DSC)	46
8.3.2 Optional MMB-84 Flush Mount Bracket	17	11.1 GENERAL	46
8.4 ELECTRICAL CONNECTIONS	18	11.2 DISTRESS ALERT	46
8.5 CONNECTION OF EXTERNAL DEVICES TO THE RADIO ..	19	11.2.1 Transmitting a Distress Alert	46
8.5.1 Connecting the NMEA 0183/NMEA 0183-HS to the Radio ..	19	11.2.2 Receiving a Distress Alert	49
8.5.2 Accessory Cables	19	11.3 ALL SHIPS CALL	50
8.5.3 Internal GPS (DSC Output) to Chart Plotter	20	11.3.1 Transmitting an All Ships Call	50
8.5.4 Connection to External GPS or Chart Plotter	20	11.3.2 Receiving an All Ships Call	51
8.5.5 Connection to External PA/HAIL Speaker	21	11.4 INDIVIDUAL CALL	52
8.5.6 Connecting optional SCU-38 External GPS Antenna ..	21	11.4.1 Setting up the Individual / Position Call Directory ..	52
8.5.7 Connecting optional SCU-31 External GPS Antenna ..	21	11.4.2 Setting up the Individual Call Reply	53
8.5.8 Optional SSM-70H (RAM4) Microphone	22	11.4.3 Enabling the Individual Call Acknowledgment	54
8.5.9 Optional SCU-30 Wireless Access Point Installation ..	24	11.4.4 Transmitting an Individual Call	54
8.6 INITIAL SETUP REQUIRED WHEN TURNING	24	11.4.5 Receiving an Individual Call	56
ON THE POWER FOR THE FIRST TIME	24	11.4.6 Setting up the Individual Call Ringer	57
8.6.1 Maritime Mobile Service Identity (MMSI)	24	11.5 GROUP CALL	58
8.7 CONFIRMING GPS SIGNAL (GPS STATUS DISPLAY)	26	11.5.1 Setting up a Group Call	58
8.8 GPS CONFIGURATION	27	11.5.2 Transmitting a Group Call	60
8.8.1 Setting the GPS Time	27	11.5.3 Receiving a Group Call	61
8.8.2 Setting the Time Area	27	11.5.4 Setting up the Group Call Ringer	62
8.8.3 Setting the Time Format	28	11.6 POSITION REQUEST	62
8.8.4 Setting COG to True or Magnetic	28	11.6.1 Setting up a Position Request Reply	63
9 BASIC OPERATION	29	11.6.2 Transmitting a Position Request to	63
9.1 TURNING THE TRANSCEIVER ON AND OFF	29	Another Vessel	63
9.2 RECEPTION	29	11.6.3 Receiving a Position Request	65
9.3 TRANSMISSION	29	11.6.4 Manual Input of Position Information	65
9.3.1 Transmit Power	30	11.6.5 Setting up a Position Request Ringer	66
9.4 BASIC OPERATION OF THE SETUP MENU	30	11.7 POSITION REPORT	66
9.5 TRANSMIT TIME-OUT TIMER (TOT)	31	11.7.1 Transmitting a DSC Position Report Call	66
9.6 SIMPLEX/DUPLEX CHANNEL USE	31	11.7.2 Receiving a DSC Position Report Call	68
9.7 CHANNEL GROUP	31	11.7.3 Navigating to the Reported Position	68
9.8 NOAA WEATHER CHANNELS	32	11.7.4 Saving the Reported Position as a Waypoint	69
9.8.1 NOAA Weather Alert	32	11.7.5 Setting up a Position Report Ringer	69
9.8.2 NOAA Weather Alert Testing	33	11.8 AUTO POSITION POLLING	70
9.9 MULTI WATCH (TO PRIORITY CHANNEL)	33	11.8.1 Setting up the Polling Operation	70
9.9.1 Setup the Multi Watch Operation	33	11.8.2 Setting up the Polling Time Interval	70
9.9.2 Starting Dual Watch	33	11.8.3 Selecting Vessels to be Automatically Polled	70
9.10 SCANNING	34	11.8.4 Enabling/Disabling Auto POS Polling	71
9.10.1 Selecting Scan Type	34	11.9 DSC TEST	71
9.10.2 Programming Scan Memory	34	11.9.1 Programming MMSI into Individual Directory	71
9.10.3 Memory Scanning (M-SCAN)	35	11.9.2 Transmitting a DSC Test to Another Vessel	72
9.10.4 Priority Scanning (P-SCAN)	35	11.9.3 Receiving a DSC Test Call	73
9.11 PRESET CHANNELS: INSTANT ACCESS	36	11.10 DSC LOG OPERATION	73
		11.10.1 Reviewing and Resending a	73
		Transmitted Logged Call	73
		11.10.2 Reviewing a Logged DSC RX Distress Alert ..	74
		and acknowledgement	74

TABLE OF CONTENTS

11.10.3	Reviewing Other Logged Calls	74	17.10	RX LED DIMMER ADJUSTMENT	108
11.10.4	Deleting Logged Calls from the DSC Log Directory	75	17.11	NOISE CANCELLATION	108
12	NAVIGATION	76	17.12	AUDIO FILTER OPERATION	109
12.1	WAYPOINT OPERATION	76	17.13	SCRAMBLER SETUP	109
12.1.1	Starting and Stopping Navigation	76	17.14	SUMMARY OF THE CANNEL FUNCTION SETUP	110
12.1.2	Setting Up Waypoint Directory	77	18	DSC SETUP	111
12.1.3	Selecting the Display Range	79	18.1	INDIVIDUAL DIRECTORY	111
12.1.4	Selecting the Arrival Range	79	18.2	INDIVIDUAL REPLY	111
12.2	ROUTING OPERATION	80	18.3	INDIVIDUAL ACKNOWLEDGMENT	111
12.2.1	Setting Up Routing Directory	80	18.4	INDIVIDUAL RINGER	111
12.2.2	Starting and Stopping Route Navigation	82	18.5	GROUP DIRECTORY	111
12.2.3	Changing the Destination	82	18.6	POSITION REPLY	112
12.2.4	Selecting Automatic or Manual Routing	82	18.7	AUTO POSITION POLLING	112
13	GM OPERATION	83	18.8	AUTO POSITION INTERVAL	112
13.1	SETTING UP GM OPERATION	83	18.9	AUTO CHANNEL CHANGE	112
13.1.1	Setting Up GM Group Directory	83	18.10	NO ACTION TIMER	113
13.1.2	Setting Up the Polling Time Interval	84	18.11	WAIT TIME FOR POSITION FIX	113
13.1.3	Enabling/Disabling Transmission during GM Operation	84	18.12	DSC BEEP	113
13.2	STARTING GM OPERATION	85	18.13	WARNING ALARM	113
13.2.1	Changing the GM Group Being Monitored	85	18.14	SUMMARY OF THE DSC SETUP MENU	114
13.2.2	Transmitting a DSC Call to a Group Member	86	19	GPS SETUP	115
13.2.3	Starting Navigation to a Group Member	86	19.1	ORDER OF PRIORITY	115
14	AUTOMATIC IDENTIFICATION SYSTEM (AIS)	87	19.2	COMPASS DIRECTION	115
14.1	GENERAL	87	19.3	LOCATION FORMAT	115
14.2	AIS OPERATION	87	19.4	TIME OFFSET	116
14.2.1	Displaying the AIS Target Information Screen	88	19.5	TIME AREA	116
14.2.2	Changing the AIS Range	89	19.6	TIME FORMAT	116
14.2.3	Transmitting an Individual Call to an AIS Ship	89	19.7	UNITS OF MEASURE	116
14.2.4	CPA/TCPA Alarm Functions	90	19.8	MAGNETIC VARIATION	116
14.2.5	Changing the Compass Display	91	19.9	NMEA 0183 IN/OUT	117
14.3	AIS SETUP	91	19.9.1	Data Speed	117
14.3.1	CPA	91	19.9.2	Output Sentences	117
14.3.2	TCPA	91	19.10	INTERNAL GPS UNIT	118
14.3.3	CPA/TCPA Alarm	92	19.10.1	Position Data Output	118
14.3.4	IGNORE VESSELS	92	19.10.2	Pinning	119
15	NMEA 2000 SETUP	94	19.10.3	Differential GPS	119
15.1	SELECT DEVICE	94	19.10.4	Logger Interval	120
15.2	DEVICE NUMBER	94	19.10.5	Log Erase	120
15.3	SYSTEM NUMBER	95	19.11	SUMMARY OF THE GPS SETUP	121
15.4	SUMMARY OF THE NMEA 2000 SETUP	95	20	SSM-70H (RAM4) REMOTE MIC OPERATION	122
15.5	COMPATIBLE NMEA 2000 PGN LIST	95	20.1	REMOTE MIC CONTROLS	122
16	CONFIGURATION SETUP	97	20.2	RAM4 SOFT KEY ASSIGNMENT	124
16.1	DISPLAY MODE	97	20.2.1	Key Assignment	125
16.2	DIMMER ADJUSTMENT	97	21	CONNECTING A USB DATA TERMINAL TO THE PC	126
16.3	DISPLAY CONTRAST	97	22	MAINTENANCE	127
16.4	KEY BEEP	98	22.1	REPLACEMENT PARTS	127
16.5	FOG ALERT TONE FREQUENCY	98	22.2	FACTORY SERVICE	127
16.6	LISTEN BACK	99	22.3	TROUBLESHOOTING CHART	128
16.7	STATION NAME	99	23	CHANNEL ASSIGNMENTS	129
16.8	SOFT KEYS	100	23.1	GX2410GPS	129
16.8.1	Key Assignment	100	24	SPECIFICATIONS	132
16.8.2	Key Timer	102	24.1	DIMENSIONS	134
16.9	RESET	102	25	FCC AND CANADA RADIO LICENSE INFORMATION	135
16.9.1	Reset the USER MMSI	103	25.1	STATION LICENSE	135
16.10	SUMMARY OF THE CONFIGURATION SETUP	105	25.2	RADIO CALL SIGN	135
17	CHANNEL FUNCTION SETUP	106	25.3	CANADIAN SHIP STATION LICENSING	135
17.1	CHANNEL GROUP	106	25.4	FCC / ISED INFORMATION	135
17.2	WEATHER ALERT	106	26	NOTICE TO USER	136
17.3	SCAN MEMORY	106	STANDARD HORIZON Limited Warranty		138
17.4	SCAN TYPE	106	TEMPLATE for the GX2410 series		139
17.5	SCAN RESUME	106			
17.6	MULTI WATCH	106			
17.7	PRIORITY CHANNEL	107			
17.8	SUB CHANNEL	107			
17.9	CHANNEL NAME	107			

QUICK REFERENCE

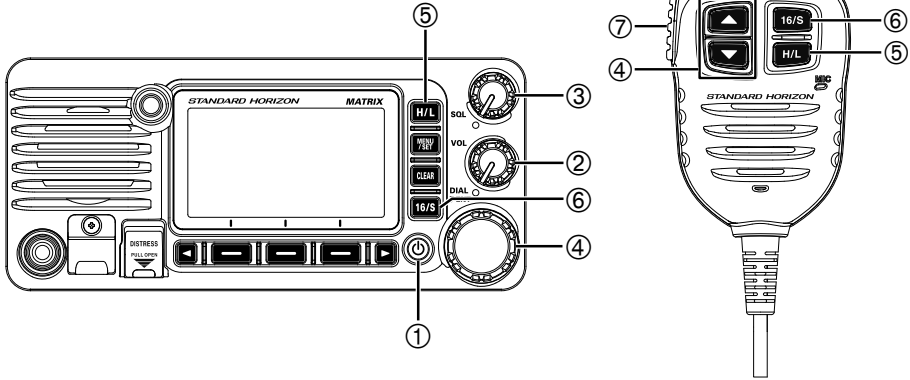

- ① Press and hold the **⏻** key to turn the radio ON or OFF.
- ② Rotate the **VOL** knob to adjust the speaker audio volume.
- ③ Rotate the **SQL** knob clockwise to squelch or counterclockwise to un-squelch the radio.
- ④ Rotate the **DIAL** knob (or press the microphone **▲/▼** keys) to select the operating channel.
- ⑤ Press the **H/L** key to toggle the transmit power between High (25W) and Low (1W).
- ⑥ Press the **16/S** key on the radio or the microphone to select channel 16. Press and hold the **16/S** key on the radio or the microphone to select sub channel. Press the **16/S** key again to revert to the previously selected channel.
- ⑦ To transmit: place the microphone about 2cm away from your mouth and speak in a normal voice level while pressing the **PTT** switch.

1 GENERAL INFORMATION

The STANDARD HORIZON **GX2410** Marine VHF/FM Marine transceiver is designed to be used in International, USA, Canadian and other Region Marine channels. The **GX2410** can be operated from 11 to 16 VDC and has a switchable RF output power of 1 watt or 25 watts.

The **GX2410** integrates a dual channel AIS (Automatic Identification System) receiver to display class A and B AIS vessel information (MMSI, Call Sign, Ship Name, BRG, DST, SOG and COG) directly on the LCD display. The **GX2410** is also capable of entering and saving up to 250 waypoints, which may be selected and navigated to by using a unique navigation compass display. The **GX2410** allows you to contact an AIS ship directly using DSC, show your vessels position in relation to AIS targets and alert you when an AIS ship may be approaching too close to your location via the Closest Point of Approach (CPA) Alarm or Time to Closest Point of Approach (TCPA) Alarm.

The **GX2410** is capable of DSC (Digital Selective Calling) ITU-R M.493-16 Class D operation with a 66-channel internal GPS. Class D operation allows continuous reception of Digital Selective Calling functions on channel 70 even while receiving calls on the voice channels. The **GX2410** operates on all currently-allocated marine channels and is switchable for use with International, USA, or Canadian regulations. Emergency channel 16 can be immediately selected from any other channel by pressing the [**16/S**] key. NOAA weather channel can also be accessed immediately by pressing the [**WX**] soft key.

Other features of the **GX2410** includes: Noise canceling function for transmit and receive audio, NMEA 2000 compatibility, high expandability, speaker microphone, 30 W PA/Loud hailer with preprogrammed fog signals and listen back, capable of being connected to one optional wired **RAM4** or four wireless **RAM4X**^{*1} remote access microphones, allowing full control of all VHF, DSC and hailer functions remotely including an intercom feature allowing you to communicate between the radio, **RAM4** and wireless **RAM4X** microphones, scanning, priority scanning, submersible speaker microphone, high and low voltage warning, and GPS repeatability. (*1 requires SCU-30 Wireless Access Port)

2 PACKING LIST

Open the package and verify it contains the following items:

- Transceiver
- DC Power Cord
- Mounting Bracket and Hardware
- Owner's Manual
- DSC Warning Sticker
- USB Cable (Type USB "A" plug to Type USB micro "B" plug) **T9101648**

3 OPTIONAL ACCESSORIES

- Flush-Mount Bracket **MMB-84**
- Remote-Access Microphone (RAM4 Microphone)*1 **SSM-70H**
*1(The SSM-70H firmware must be Ver. 3.00.00 or later.)
- Wireless Remote Access Microphone (RAM4X Microphone).. **SSM-72H**
- Wireless Access Point for SSM-72H*2 **SCU-30**
*2 (To connect the SSM-72H (RAM4X), the SCU-30 firmware must be Ver. 2.00.00 or later.)
- USB DC Charger with Cigarette Lighter Plug for SSM-72H **SDD-14**
- External GPS Antenna with 16 ft (5m) of Cable **SCU-38**
- 23 ft (7m) Extension Cable for SSM-70H **CT-100**
- External Loud Speaker **MLS-410SP**
- 5" Round 30 Watt Hail/PA Horn **220SW**
- 5" × 8" Rectangular 40 Watt Hail/PA Horn **240SW**
- Dust Cover (White) **HC2400**

4 ONLINE WARRANTY REGISTRATION

Please visit **www.standardhorizon.com** - Owner's Corner to register the **GX2410** Marine VHF Transceiver.

NOTE: Visiting the STANDARD HORIZON website from time to time may be beneficial. When new products are released, information will appear on the website.

5 Safety Precautions (Be Sure to Read)

Be sure to read these important precautions, and use this product safely.

Yaesu is not liable for any failures or problems caused by the use or misuse of this product by the purchaser or any third party. Also, Yaesu is not liable for damages caused through the use of this product by the purchaser or any third party, except in cases where ordered to pay damages under the laws.

Types and meanings of the marks



DANGER

This mark indicates an imminently hazardous situation, which, if not avoided, could result in death or serious injury.



WARNING

This mark indicates a potentially hazardous situation, which, if not avoided, could result in death or serious injury.



CAUTION

This mark indicates a potentially hazardous situation, which, if not avoided, may result in minor or moderate injury or only property damage.

Types and meanings of symbols



These symbols signify prohibited actions, which must not be done to use this product safely. For example:  indicates that the product should not be disassembled.



These symbols signify required actions, which must be done to use this product safely. For example:  indicates the power plug should be disconnected.



DANGER



Do not operate the device when flammable gas is generated.
Doing so may result in fire and explosion.



If thunder and lightning develop nearby when an external antenna is used, immediately turn this transceiver OFF, and disconnect the external antenna from it.
A fire, electrical shock, or damage may result.



Do not transmit with this device while carrying or using a medical appliance such as a cardiac pacemaker. When transmitting, use an external antenna and keep as far as possible away from the external antenna.
The radio wave emitted by the transmitter can cause the medical device to malfunction and result in injury or death.



Do not touch any liquid leaking from the liquid display with your bare hands.
There is a risk of chemical burns occurring when the liquid comes into contact with the skin or gets into the eyes. In this case, seek medical treatment immediately.



WARNING



Do not power this transceiver with a voltage other than the specified power supply voltage.
A fire, electric shock, or damage may result.



Do not handle the power plug and connector etc. with wet hands. Also do not plug and unplug the power plug with wet hands.
This may result in injury, liquid leak, electric shock and equipment failure.



Do not make very long transmissions.
The main body of the transceiver may overheat, resulting component failure or operator burns.



Do not disassemble or make any alteration to this product.
An injury, electric shock, or failure may result.



Disconnect the power cord and connection cables before incorporating items sold separately or replacing the fuse.
This may result in fire, electric shock and equipment failure.



Never touch the antenna during transmission.
This may result in injury, electric shock and equipment failure.



When smoke or strange odors are emitted from the radio, turn off the power and disconnect the power cord from the socket.

This may result in fire, liquid leak, overheating, damage, ignition and equipment failure. Please contact our company customer support or the retail store where you purchased the device.



Keep the power plug pins and the surrounding areas clean at all time.

This may result in fire, liquid leak, overheating, breakage, ignition etc.



Never cut the fuse holder off of the DC power cord.

This may cause a short circuit and result in ignition and fire.



Use only the specified type fuses.

Use of an incorrect fuse may result in fire and equipment failure.



When connecting a DC power cord, be certain the positive and negative polarities are correct. Reverse connection will result in equipment damage.



Do not use DC power cords other than the one enclosed or specified.

This may result in fire, electric shock and equipment malfunctions.



Do not bend, twist, pull, heat and modify the power cord and connection cables in an unreasonable manner.

This may cut or damage the cables and result in fire, electric shock and equipment failure.



Do not pull the cable when plugging and unplugging the power cord and connection cables.

Always hold the plug or connector when unplugging; if not, a fire, electric shock and equipment failure may result.



Do not use the device when the power cord and connection cables are damaged, or when the DC power connector cannot be plugged in tightly.

Contact Yaesu Amateur Customer Support or the retail store where this transceiver was purchased for assistance, as this may result in fire, electric shock and equipment failure.



Follow the instructions provided when installing items sold separately and replacing the fuse.

This may result in fire, electric shock and equipment failure.



Use only the provided or specified screws.

Using screws of a different size, may result in fire, electric shock and component damage.



CAUTION



Do not place the transceiver on an unsteady or sloping surface, or in a location with extreme vibration.

The transceiver may fall or drop, resulting in fire, injury and equipment damage.



Stay as far away from the antenna as possible during transmission.

Long-term exposure to electromagnetic radiation may have a negative effect on the human body.



Do not wipe the case using thinner and benzene etc.

Use only a soft, dry cloth to wipe stains from the case.



Keep this product out of the reach of children. Injury to the child, or damage to the transceiver may result.



Do not put heavy objects on top of the power cord and connection cables.

This may damage the power cord and connection cables, resulting in fire and electric shock.



Do not use any products other than the specified options and accessories.

Failure or miss operation may result.



For safety reasons, switch off the power and pull out the DC power cord connected to the DC power connector when the device is not going to be used for a long period of time.

If not, this may result in fire and overheating.



Do not throw the transceiver, or subject it to strong impact forces.

Physical abuse may result in component damage and equipment failure.



Keep magnetic cards and videotapes away from the transceiver.

The data recorded on cash cards or videotapes may be erased.



Do not stand on top of the product, and do not place heavy objects on top or insert objects inside it.

If not, this may result in equipment failure.

6 GETTING STARTED

6.1 ABOUT VHF RADIO

The radio frequencies used in the VHF marine band lie between 156 and 158MHz with some shore stations available between 161 and 163MHz. The marine VHF band provides communications over distances that are essentially “line of sight” (VHF signals do not travel well through objects such as buildings, hills or trees). Actual transmission range depends much more on antenna type, gain and height than on the power output of the transmitter. On a fixed mount 25W radio transmission expected distances can be greater than 25km, for a portable 5W radio transmission the expected distance can be greater than 8km in “line of sight”.

6.2 SELECTING AN ANTENNA

Marine antennas are made to radiate signals equally in all horizontal directions, but not straight up. The objective of a marine antenna is to enhance the signal toward the horizon. The degree to which this is accomplished is called the antenna gain. It is measured in decibels (dB) and is one of the major factors in choosing an antenna. In terms of effective radiated power (ERP), antennas are rated on the basis of how much gain they have over a theoretical antenna with zero gain. A 1m, 3dB gain antenna represents twice as much gain over the imaginary antenna.

Typically, a 1 m 3dB gain stainless steel whip is used on a sailboat mast. The longer 2.5m 6dB fiberglass whip is primarily used on power boats that require the additional gain.

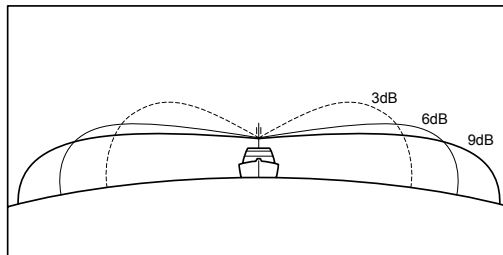

6.3 COAXIAL CABLE

VHF antennas are connected to the transceiver by means of a coaxial cable – a shielded transmission line. Coaxial cable is specified by its diameter and construction.

For runs less than 20 feet (6m), RG-58/U (about 0.25" (6mm) in diameter), is a good choice. For runs over 20 feet (6m) but less than 50 feet (15m), the larger RG-8X or RG-213/U should be used. For cable runs over 50 feet (15m) RG-8X should be used. For installation of the connector onto the coaxial cable refer to the figure.

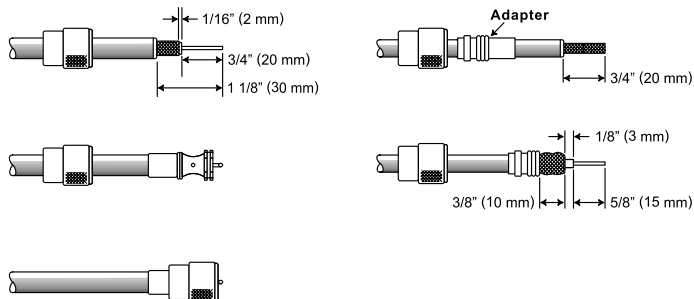

To get the coax cable through a fitting and into the boat's interior, you may have to cut the end plug off and reattach it later. Follow the directions that come with the connector to attach it. Be sure to make good soldered connections.

6.4 DISTRESS AND HAILING (CHANNEL 16)

Channel 16 is known as the Hail and Distress Channel. An emergency may be defined as a threat to life or property. In such instances, be sure the transceiver is ON and set to CHANNEL 16. Then use the following procedure:

1. Press the microphone push-to-talk switch and say "**Mayday, Mayday, Mayday**". This is _____, _____, _____" (your vessel's name).
2. Then repeat once: "**Mayday, _____**" (your vessel's name).
3. Now report your position in latitude/longitude, or by giving a true or magnetic bearing (state which) to a well-known landmark such as a navigation aid or geographic feature such as an island or harbor entry.
4. Explain the nature of your distress (sinking, collision, aground, fire, heart attack, life-threatening injury, etc.).
5. State the kind of assistance your desire (pumps, medical aid, etc.).
6. Report the number of persons aboard and condition of any injured.
7. Estimate the present seaworthiness and condition of your vessel.
8. Give your vessel's description: length, design (power or sail), color and other distinguishing marks. The total transmission should not exceed 1 minute.
9. End the message by saying "**OVER**". Release the microphone switch and listen.
10. If there is no answer, repeat the above procedure. If there is still no response, try another channel.

NOTE

The transceiver has the DSC Distress calling, that can transmit a distress call digitally to all ships with compatible DSC radios. Refer to section "**11 DIGITAL SELECTIVE CALLING (DSC)**".

6.5 CALLING ANOTHER VESSEL (CHANNEL 16 OR 9)

Channel 16 may be used for initial contact (hailing) with another vessel. However, its most important use is for emergency messages. This channel must be monitored at all times, except when actually using another channel.

It is monitored by the U.S. and Canadian Coast Guards and by other vessels.

Use of channel 16 for hailing must be limited to initial contact only. Calling should not exceed 30 seconds, but may be repeated 3 times at 2-minute intervals. In areas of heavy radio traffic, congestion on channel 16 resulting from its use as a hailing channel can be reduced significantly in U.S. waters by using **channel 9** as the initial contact (hailing) channel for non-emergency communications. Here, also, calling time should not exceed 30 seconds but may be repeated 3 times at 2-minute intervals.

Prior to contacting with another vessel, refer to the channel charts in this manual, and select an appropriate channel for communications after initial contact. For example, Channels 68 and 69 of the U.S. VHF Charts are some of the channels available to non-commercial (recreational) boaters. Monitor the desired channel in advance to make sure you will not be interrupting other traffic, and then go back to either channel 16 or 9 to make initial contact.

When the hailing channel (16 or 9) is clear, press the **PTT** switch on the mic and state the name of the other vessel you wish to call and then “this is” followed by the name of your vessel and your Station License (Call Sign) then release the **PTT** switch on the mic. When the other vessel returns your call, immediately request another channel by pressing the **PTT** switch on the mic and saying “**go to**,” the number of the other channel, say “**over**” and release the **PTT** switch on the mic. Then switch to the new channel. When the new channel is not busy, call the other vessel.

After a transmission, say “**over**,” and release the microphone’s push-to-talk (**PTT**) switch. When all communication with the other vessel is completed, end the last transmission by stating your Call Sign and the word “**out**.” Note that it is not necessary to state your Call Sign with each transmission, only at the beginning and end of the contact.

Remember to return to Channel 16 when not using another channel. Some radios automatically monitor Channel 16 even when set to other channels or when scanning.

6.6 WHAT IS THE RANGE FOR AIS RECEIVERS?

Since AIS uses similar frequencies as a marine VHF radio, it has similar radio reception capabilities - which are basically line of sight. This means that the higher the VHF antenna is mounted, the greater the reception area will be. Reception from Class A vessels that are 20 or even 30 miles away on open water is not uncommon as their antennas are mounted high off the water. Class B transponders use lower power for transmissions; therefore, you can expect Class B vessels to be acquired when they are 5 to 10 miles away.

NOTE

For additional information on AIS visit the USCG website:
<<http://www.navcen.uscg.gov/marcomms/ais.htm>>

6.7 Accuracy of COG

The error in the COG (the path of the antenna position over ground) due to the actual ship's speed over ground shall not exceed the following values:

Speed range (knots)	Accuracy of COG output to user
0 to ≤ 1 knot	Unreliable or not available
>1 to ≤ 17 knots	$\pm 3^\circ$
>17 knots	$\pm 1^\circ$

7 CONTROLS AND INDICATORS

This section defines each control of the transceiver. See illustration below for location of controls. For detailed operating instructions refer to “9 BASIC OPERATION” of this manual.

7.1 FRONT PANEL

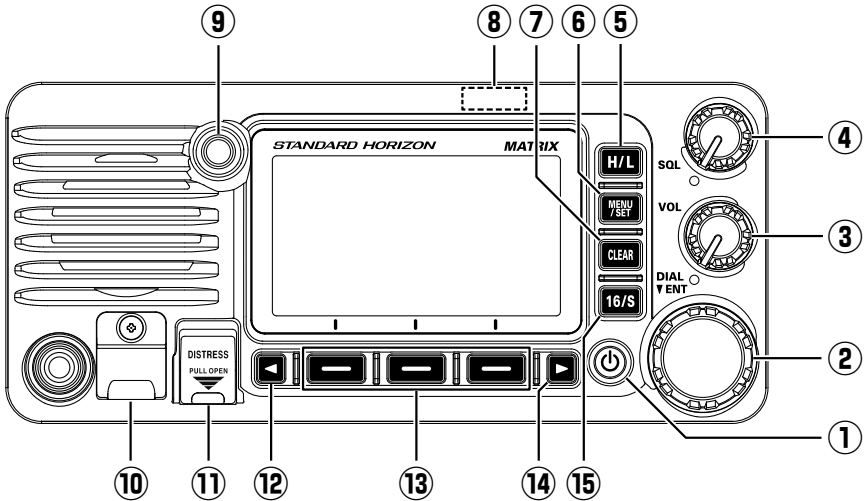

① **⏻ (Power) key**

Press and hold to toggle the radio **ON** or **OFF**. When the power is turned **ON**, the transceiver is set to the last selected channel.

② **DIAL/ENT knob**

While the normal screen is displayed, rotate the DIAL/ENT knob to change the operating channel. While the MENU screen is displayed, rotate the knob to select the menu item.

SECONDARY USE

- Press this knob to enter a selection in the MENU.

③ **VOL knob** (Volume control)

Adjusts the audio volume level.

Clockwise rotation of this knob increases the internal and speaker microphone volume.

④ **SQL knob** (Squelch control)

Adjusting this control clockwise, sets the point at which random noise on the channel does not activate the audio circuits but a received signal will be heard. This point is called the squelch threshold. Further adjustment of the squelch control will degrade reception of wanted transmissions.

⑤ **H/L key**

Press this key to toggle between 25W (High) and 1W (Low) power. When the TX output power is set to “Low” while the transceiver is on channel 13 or 67 (USA Channel group only), the output power will temporarily switch from “Low” to “High” power until the **PTT** switch of the microphone is released. This key is not available on transmit inhibited and low power only channels.

⑥ **MENU/SET key**

Press to access MENU.

Press and hold to access SETUP MENU. For details, refer to section “**9.4 BASIC OPERATION OF THE SETUP MENU**”.

⑦ **CLEAR key**

Press this key to cancel a menu selection.

⑧ **GPS Antenna**

Built in GPS antenna is located here.

⑨ **BUSY Indicator LED**

This indicator glows green when the squelch opens.

⑩ **DATA jack**

Use the USB micro type B jack to configure the transceiver settings and download* the GPS logger data.

NOTE: When the DATA jack is securely covered with rubber cap, the GX2410 meets the waterproofing performance.

⑪ **DISTRESS key**

Used to send a DSC Distress Call. To send the distress call, refer to section “**11.2.1 Transmitting a Distress Alert**”.

⑫ / ⑭ **◀ & ▶ key**

When the soft keys are displayed, press these keys to switch the function of soft keys.

SECONDARY USE

While the MENU screen is displayed, press the key to slide the on-screen menu to the right/left side.

⑬ **Soft keys**

Press these keys to display the soft keys.

The 3 programmable soft keys can be customized by the Setup Menu described in section “**16.8 SOFT KEYS**”.

⑮ **16/S key**

Pressing this key immediately recalls channel 16 from any channel location. Holding down this key selects the SUB channel (The default SUB channel setting is channel 9). Pressing this key again reverts to the previous selected working channel.

7.2 MICROPHONE

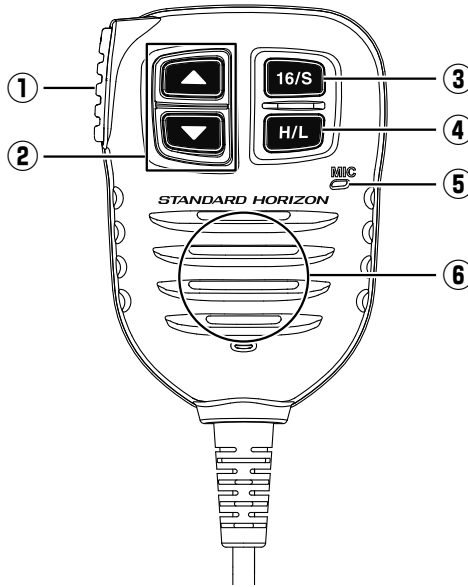

① **PTT (Push-To-Talk) switch**

When in radio mode and the **PTT** switch is pressed, the transmitter is enabled for voice communications to another vessel.

When an optional **SSM-70H** Microphone or **SSM-72H** Wireless Microphone is connected and intercom mode is selected, pressing the **PTT** switch enables voice communications from the transceiver to the **SSM-70H** Microphone or the **SSM-72H** Wireless Microphone.

② **▲ & ▼ key**

These keys on the microphone are used to select channels and to choose menu items.

③ **16/S key**

Pressing this key immediately selects channel 16 from any channel location. Holding down this key selects the Sub channel (The default SUB channel setting is channel 9). Pressing this key again reverts to the previous selected working channel.

④ **H/L key**

Press this key to toggle between 25W (High) and 1W (Low) power. When the TX output power is set to “Low” and the transceiver is on channel 13 or 67 (USA Channel group only), the output power will temporarily switch from “Low” to “High” power until the **PTT** switch of the microphone is released. High power TX is not available on transmit inhibited and low power only channels.

⑤ **Microphone**

The internal microphone transmits your voice and reduces background noise using Clear Voice Noise Reduction Technology. When transmitting, position the microphone about 2cm away from your mouth. Speak slowly and clearly into the microphone.

⑥ **Microphone speaker**

Audio heard through internal radio speaker is heard through the speaker microphone.

7.3 REAR PANEL

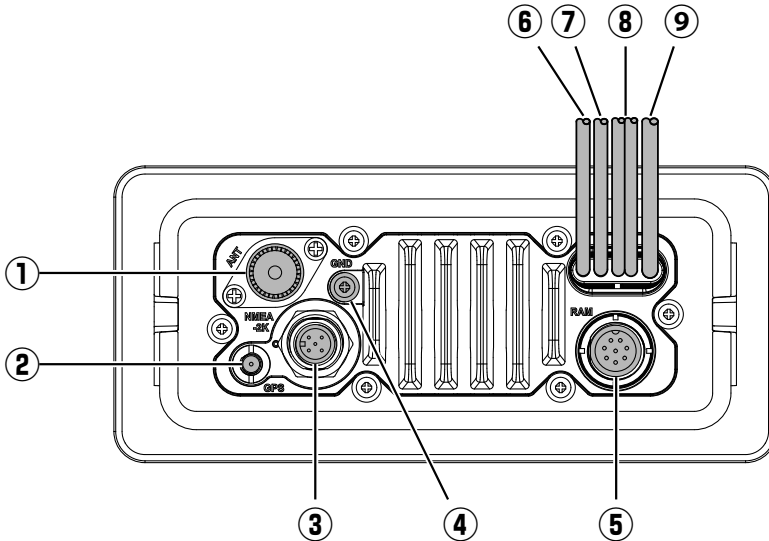

① **VHF ANT Jack** (VHF antenna jack)

Connects an antenna to the transceiver. Use a marine VHF antenna with an impedance of 50 ohms.

② **GPS ANT Connector**

Connects the optional **SCU-38** External GPS Antenna.

③ **NMEA 2K Connector**

Connects to the NMEA 2000 network.

④ **GND Terminal** (Ground Terminal)

Connects the transceiver to ships ground, for safe and optimum performance. Use the screw supplied with the transceiver only.

- ⑤ **RAM Remote Access Microphone Connector**
Connects the **GX2410** to the **SSM-70H (RAM4)** Remote Station Microphone or the **SCU-30** Wireless Access Point for use with up to four **SSM-72H (RAM4X)** wireless microphones. Refer to section “**20 SSM-70H (RAM4) REMOTE MIC OPERATION**” for details.
- ⑥ **EXTERNAL Speaker Connection Cable (White & Shield)**
Connects the transceiver to an optional external speaker. See section “**3 OPTIONAL ACCESSORIES**” for the available optional STANDARD HORIZON accessories.
Speaker connections:
White: External Speaker (+)
Shield: External Speaker (-)
- ⑦ **PA/HAIL Speaker Connection Cable (Red & Shield)**
Connects the GX2410 to PA/HAIL speaker. See section “**3 OPTIONAL ACCESSORIES**” for the available optional STANDARD HORIZON PA/HAIL Speakers.
PA Speaker connections:
Red: PA Speaker (+)
Shield: PA Speaker (-)
- ⑧ **DC Input Cable**
Connects the transceiver to a DC power supply capable of delivering 11 to 16 VDC.
- ⑨ **Accessory Connection Cable (Blue, Gray, White, Brown, Yellow, and Green)**
Connects the transceiver to a GPS chart plotter. Refer to section “**8.5.2 Accessory Cables**”.

8 INSTALLATION

8.1 SAFETY / WARNING INFORMATION

Operation of this radio is restricted to occupational use, work related operations only where the radio operator must have the knowledge to control the exposure conditions of passengers and bystanders by maintaining the minimum separation distance of 3 feet (1m). Failure to observe these restrictions will result in exceeding the FCC RF exposure limits.

Antenna Installation:

The antenna must be located at least 3 feet (1m) away from passengers in order to comply with the FCC RF exposure requirements.

8.2 LOCATION

The radio can be mounted at any angle. Choose a mounting location that:

- complies with the compass safe distances shown in the table below to prevent interference to a magnetic compass

Transceiver Unit	1.0m
Handset	0.5m

- provides accessibility to the front panel controls
- allows connection to a power source and antennas
- has nearby space for installation of a microphone hanger
- is at least 3 feet (1m) away from the radio's antenna
- the signals from the GPS satellites can be adequately received

NOTE: To insure the radio does not affect the compass or radio's performance is not affected by the antenna location, temporarily connect the radio in the desired location and:

- a. Examine the compass to see if the radio causes any deviation
- b. Connect the antenna and key the radio. Check to ensure the radio is operating correctly by requesting a radio check.

8.3 MOUNTING THE RADIO

8.3.1 Supplied Mounting Bracket

The supplied mounting bracket allows desktop mounting.

Use a 13/64" (5.2mm) bit to drill the holes to a surface which is more 0.4 inch (10mm) thick and can support more than 3.3 lbs (1.5kg) and secure the bracket with the supplied screws, spring washers, flat washers, and nuts.

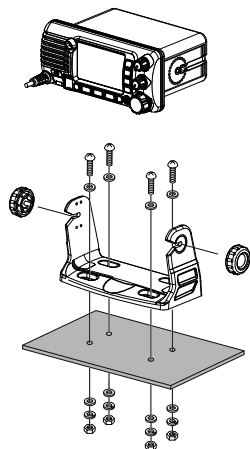

Desktop Mounting

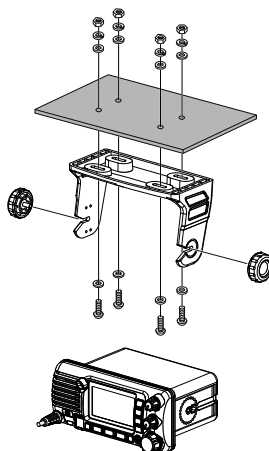

Overhead Mounting

8.3.2 Optional MMB-84 Flush Mount Bracket

A GPS receiver and antenna are located in the front panel of the **GX2410**. In many cases the radio may be flush mounted, however before cutting holes to flush mount the radio it is recommended to temporarily connect the radio to power and turn it ON in the location where it will be flush mounted to confirm on the display that it is able to receive a GPS location. If the radio is not able to receive a location, a connection to a GPS Chart plotter with NMEA 0183 output, or the optional **SCU-38** External GPS Antenna may be needed to receive GPS satellite signals.

1. Use the template (page 139) to mark the location where the rectangular hole is to be cut. Confirm the space behind the dash or panel is deep enough to accommodate the transceiver (at least 6.2 inches (157mm) deep). There should be at least 1/2 inch (1.3cm) between the transceiver's heatsink and any wiring, cables or structures.
2. Cut out the rectangular hole and insert the transceiver.
3. Fasten the brackets to the rear panel of the transceiver (see illustration).
4. Turn the adjusting screw to adjust the tension so that the transceiver is tight against the mounting surface.

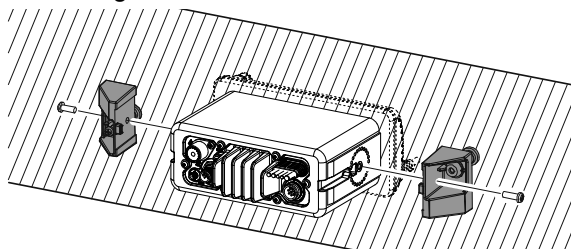

8.4 ELECTRICAL CONNECTIONS

CAUTION

Reverse polarity battery connections will damage the radio!

Connect the power cord and antenna to the radio. Antenna and Power Supply connections are as follows:

1. Mount the antenna at least 3.28 feet (1m) away from the radio. At the rear of the radio, connect the antenna cable. The antenna cable must have a PL259 connector attached. RG-8/U coaxial cable must be used if the antenna is 25 feet (7.6m) or more from the radio. RG58 cable can be used for distances less than 25 feet (7.6m).
2. Connect the red power wire to a 13.8 VDC \pm 20% power source. Connect the black power wire to a negative ground.
3. If an optional external speaker is to be used, refer to section 8.5 for connections.
4. It is advisable to have a Certified Marine Technician check the power output and the standing wave ratio of the antenna after installation.

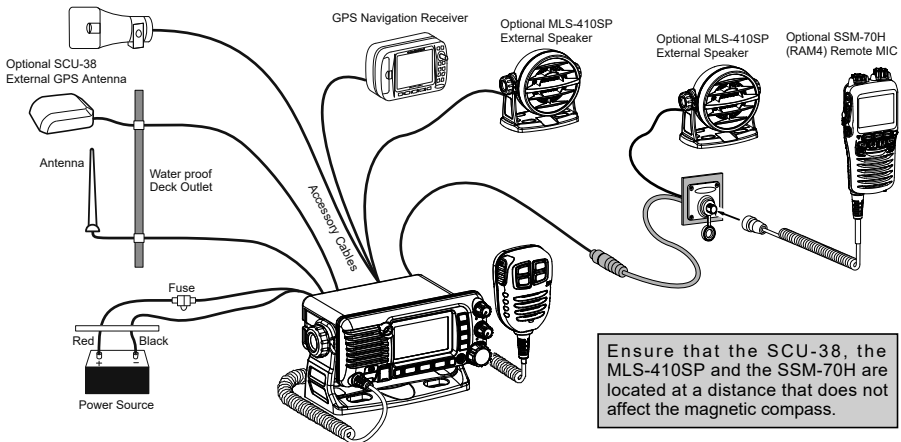

Fuse Replacement

To remove the fuse from the fuse holder, hold both ends of the fuse holder and pull the fuse holder apart without bending the fuse holder. When replacing the fuse, confirm that the fuse is tightly fixed into the metal contact located inside the fuse holder. If the metal contact holding the fuse is loose, the fuse holder may heat up.

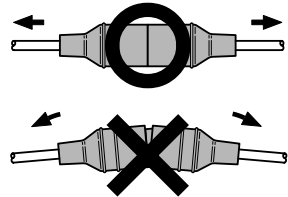

8.5 CONNECTION OF EXTERNAL DEVICES TO THE RADIO

8.5.1 Connecting the NMEA 0183/NMEA 0183-HS to the Radio

External GPS Device Connections (NMEA 0183 4800 baud or NMEA 0183-HS 38400 baud)

The **GX2410** can select the NMEA baud rate between “4800 bps” and “38400 bps”. Refer to section “**19.9 NMEA 0183 IN/OUT**” for selection.

NMEA Input (GPS Information)

- The transceiver can read NMEA 0183 version 2.0 or higher, and NMEA 0183-HS version 1.01 or higher.
- The NMEA 0183 input sentences are GLL, GGA, RMC, GNS, GSA, and GSV (RMC sentence is recommended).
- If 4800 baud (default) is selected:
The Yellow and Green input wires are at 4800 baud.
- If 38400 baud is selected:
The Yellow and Green input wires are at 38400 baud.

NMEA Output (DSC and GPS information)

- The NMEA 0183 output sentences are DSC and DSE.
- If 4800 baud (default) is selected:
The White and Brown wires output DSC and DSE sentences.
- If 38400 baud is selected:
The Blue and Gray output wires are at 38400 baud and include DSC (DSC, DSE) sentences.
- GSA, GSV, GLL, GGA, and RMC sentences can be output from the transceiver using settings in the GPS setup menu (refer to section “**19.9 NMEA 0183 IN/OUT**”).

For further information on interfacing and setting up GPS operation, contact the manufacturer of the externally connected GPS receiver.

If you have further questions, please contact your Dealer.

8.5.2 Accessory Cables

The image and table below show the wires of the transceiver and the connections to optional devices such as an external GPS antenna and a GPS chart plotter.

CAUTION

Care must be taken not to touch any of the NMEA wires to positive 12 VDC or the radio may be damaged.

When connecting the Chart Plotter, External GPS receiver, or External Speaker strip off about 1 inch (2.5cm) of the specified wire's insulation, then splice the ends together.

The transceiver uses NMEA 0183/-HS protocol to share coordinates and DSC information to and from a GPS chart plotter.

8.5.3 Internal GPS (DSC Output) to Chart Plotter

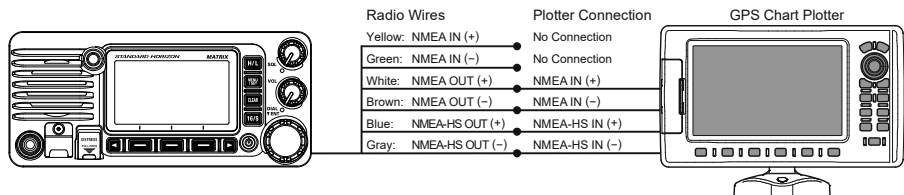

Wire Color/Description	Connection Examples
YELLOW - NMEA GPS Input (+)	No connection
GREEN - NMEA GPS Input (-)	No connection
WHITE - NMEA DSC Output (+)	NMEA (+) input of GPS* ¹
BROWN - NMEA DSC Output (-)	NMEA (-) input of GPS* ¹
BLUE - AIS Data Output (+)	NMEA-HS (+) input of AIS receiver* ²
GRAY - AIS Data Output (-)	NMEA-HS (-) input of AIS receiver* ²

*1: 4800 baud, *2: 38400 baud

NOTE: Some GPS chart plotters have a single wire for NMEA signal ground. In this case, connect the NMEA input (-) to the GPS chart plotter's single NMEA signal ground wire, and leave the NMEA output (-) open. In case the assignment of power supply and ground of a GPS chart plotter to be used is different from that of the radio, connect the signal ground wire of the GPS chart plotter to the ground terminal (GND) on the rear panel of the radio.

8.5.4 Connection to External GPS or Chart Plotter

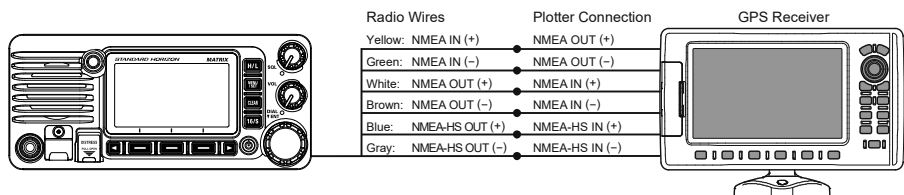

Wire Color/Description	Connection Examples
YELLOW - NMEA GPS Input (+)	NMEA (+) output of GPS* ¹
GREEN - NMEA GPS Input (-)	NMEA (-) output or common ground of GPS* ¹
WHITE - NMEA DSC Output (+)	NMEA (+) input of GPS* ¹
BROWN - NMEA DSC Output (-)	NMEA (-) input of GPS* ¹
BLUE - AIS Data Output (+)	NMEA-HS (+) input of AIS receiver* ²
GRAY - AIS Data Output (-)	NMEA-HS (-) input of AIS receiver* ²

*1: 4800 baud , *2: 38400 baud

NOTE: To input the GPS coordinates from an external GPS device to the transceiver, the NMEA GPS input (+) (yellow) and the NMEA GPS input (-) (green) wires may be connected to the NMEA output of the external GPS antenna or GPS chart plotter.

To connect with an external device at 38400 baud

To connect with an external device at 38400 baud, the transceiver may be setup to receive GPS coordinates and send DSC signals at 38400 baud. Refer to section "19.9 NMEA 0183 IN/OUT" for details.

8.5.5 Connection to External PA/HAIL Speaker

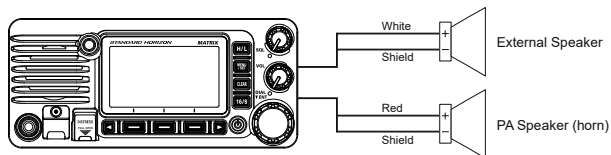

Wire Color/Description	Connection Examples
White - External Speaker (+)	Positive wire of external 4 Ohm External speaker
Shield - External Speaker (-)	Negative wire of external 4 Ohm External speaker
Red - PA Speaker (+)	Positive wire of external 4 Ohm audio speaker (horn)
Shield - PA Speaker (-)	Negative wire of external 4 Ohm audio speaker (horn)

8.5.6 Connecting optional SCU-38 External GPS Antenna

Connect the **SCU-38** cable to the coaxial GPS ANT connector on the rear panel, then tighten the cable nut (see illustration at the right).

NOTE: The **SCU-38** is always more preferred than the internal GPS antenna.

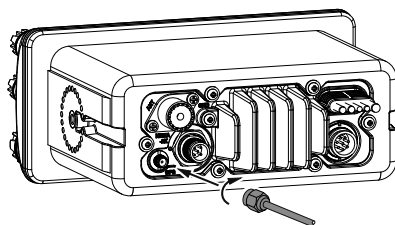

8.5.7 Connecting optional SCU-31 External GPS Antenna

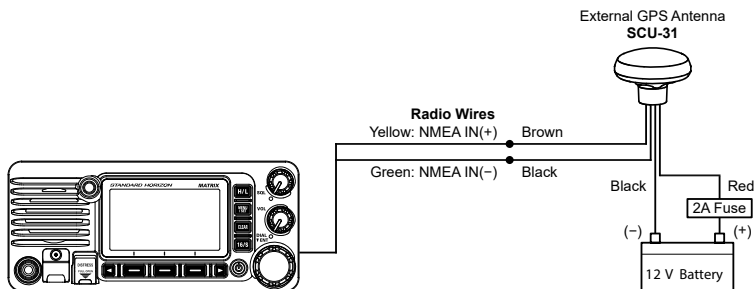

NOTE

To connect optional **SCU-31**, the transceiver may be setup to receive GPS coordinates at 4800 baud. Refer to section “**19.9 NMEA 0183 IN/OUT**” for details.

The **SCU-31** External GPS Antenna (Built-in GPS receiver) is supplied with 49 feet (15m) of cable and a connector. To connect the **SCU-31** to the transceiver, cut off the 6 pin antenna connector, strip the white insulation to expose the Red, Black and Brown wires and connect as shown in the diagram. All other wires are not used and may be cut off. The 2 amp fuse is not included.

8.5.8 Optional SSM-70H (RAM4) Microphone

NOTE

To connect the GX2410, the SSM-70H firmware must be Ver. 3.00.00 or later.

The transceiver is capable of using an **SSM-70H (RAM4)** Remote Station Microphone to control all the Radio functions. In addition, the transceiver can operate as a full function intercom system between the **SSM-70H** microphone and the transceiver.

WARNING

Do not connect or remove the SSM-70H (RAM4) microphone while the radio is powered ON. This may result in equipment failure.

1. Connect the Routing Cable (supplied with the **SSM-70H**) to the **RAM** connector (eight pins) on the rear panel, then tighten the cable nut (see the below illustration).

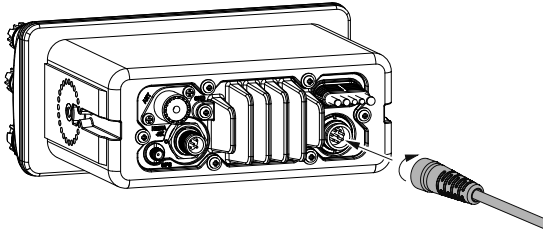

2. Install the two ferrite cores (supplied with the **SSM-70H** Remote Station Microphone) to the routing cable or the **CT-100** extension cable, then snap the halves together. These cores should be installed near the connectors of the transceiver and the microphone ends of the cable.
3. Attach the ferrite cores as close as possible to the plugs, as shown below.

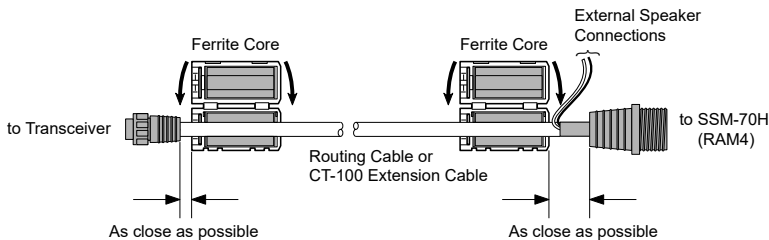

CAUTION

Before cutting the cable, it must be disconnected from the rear panel of the transceiver.

The routing cable can be cut and spliced, however care needs to be taken when reconnecting the wires to ensure water integrity.

After cutting you will notice there are the following wires:

Yellow, Green, White, Brown and Red/Shield

4. Finally, wind some plastic tape around each ferrite core, to prevent vibration from causing the two halves to split apart.
5. Referring to the illustration at the right, make a 30mm hole in the wall, then insert the extension cable into this hole. Connect the gasket and mount base to the extension cable connector using the nut.
6. Drill the four screw holes (approx. 2mm) into the wall, then install the mounting base to the wall using four screws.
7. Put the rubber cap onto the nut. The installation is now complete.

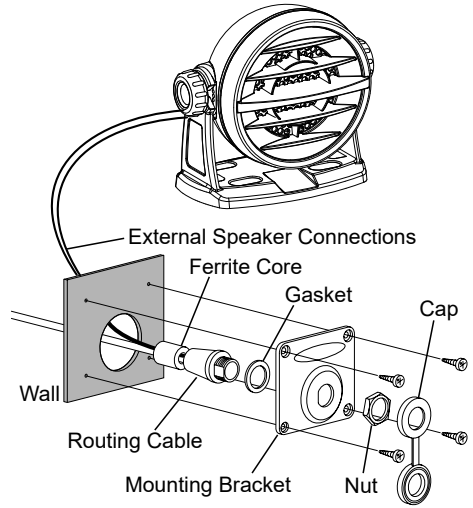

WARNING

It is not recommended to plug or unplug the SSM-70H (RAM4) Remote Station Microphone into the routing cable while the radio is powered ON.

Connecting an External Speaker to the RAM4 Mic Cable

In noisy locations and the **MLS-410SP** optional external speaker may be connected to the white speaker wires on the **RAM4** routing cable. The **RAM4** can drive either the internal speaker or the external speaker one at a time. When connecting an external speaker, follow the procedure below to turn the **RAM4** audio OFF and enable the external speaker connected to the **RAM4** routing cable wires.

1. On the **RAM4** microphone, press and hold the **[MENU/SET]** key.
2. Rotate the **DIAL/ENT** knob to select “**CONFIGURATION**”, then press the **[SELECT]** soft key.
3. Rotate the **DIAL/ENT** knob to select “**SPEAKER SELECT**”, then press the **[SELECT]**.
4. Rotate the **DIAL/ENT** knob to select “**INTERNAL**” or “**EXTERNAL**”, then press the **[SELECT]** soft key.

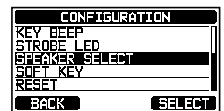

5. Press the [CLEAR] key to return to radio operation.

8.5.9 Optional SCU-30 Wireless Access Point Installation

NOTE

To connect the SSM-72H (RAM4X), the SCU-30 firmware must be Ver. 2.00.00 or later.

The **GX2410** is capable of using a **SSM-72H (RAM4X)** Wireless Remote Station Microphone to remotely control the Radio, AIS, DSC and PA/Fog functions. In addition the **GX2410** can operate as a full function intercom system between the **RAM4X** and the **GX2410**.

The optional **SCU-30** Wireless Access Point, may be utilized to connect up to four **RAM4X** Wireless Remote Access Microphones to the **GX2410**.

WARNING

Do not connect or remove the SCU-30 Wireless Access Point while the radio is powered ON. This could result in damage to the equipment.

1. Connect the **SCU-30** Cable to the **RAM** Connector on the **GX2410** rear panel, and tighten the cable nut.

NOTE: For additional details on the connecting the **RAM4X** and **GX2410**, refer to the **RAM4X** Instruction Manual.

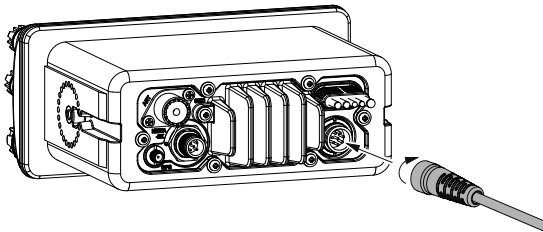

8.6 INITIAL SETUP REQUIRED WHEN TURNING ON THE POWER FOR THE FIRST TIME

8.6.1 Maritime Mobile Service Identity (MMSI)

What is an MMSI?

An MMSI is a nine-digit number used on marine transceivers capable of using Digital Selective Calling (DSC) signal transmission. This number is used like a telephone number to selectively call other vessels.

THIS NUMBER MUST BE PROGRAMMED INTO THE RADIO TO OPERATE DSC FUNCTIONS.

How can I obtain an MMSI assignment?

Contact the Radio Licensing Authority for your country for information on obtaining an MMSI number.

WARNING

The MMSI can be input only once, be careful not to input the incorrect MMSI number. If the MMSI number needs to be reset, contact Standard Horizon to obtain the required reset code. Refer to section “16.9.1 Reset the USER MMSI”.

Programming the MMSI

1. Press the [MENU/SET] key to display “MENU”.
2. Rotate the DIAL/ENT knob to select “MMSI/POS INFO”, then press the [SELECT] soft key. (To cancel, press the [BACK] soft key.)
3. The “MMSI INPUT” screen is displayed if the MMSI has not yet been input.

When the transceiver entry has been completed, it is only possible to check the MMSI on this screen.

4. Press the [◀] or [▶] key to select the first number of your MMSI, then press the [SELECT] soft key to step to the next number.
5. Repeat step 4 to set your MMSI number (9 digits). If a mistake is made entering in the MMSI number, press the [◀] or [▶] key to select “←” or “→”, press the [SELECT] soft key until the incorrect character is selected, then perform step 4.
6. When finished programming the MMSI number, press the [FINISH] soft key. The radio will ask you to input the MMSI number again. Perform steps 4 through 6 above.
7. After the second number has been input, press the [FINISH] soft key to store the MMSI.
8. Press the [OK] soft key to return to radio operation.

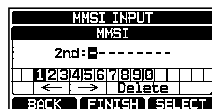
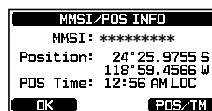
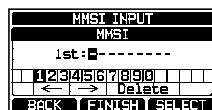

NOTE

To check the MMSI after programming to ensure it is correct, perform steps 1 to 2. The current MMSI number is shown on the display.

8.7 CONFIRMING GPS SIGNAL (GPS STATUS DISPLAY)

When the **GX2410** receives the GPS signal from the internal GPS receiver , a small satellite icon “**GPS**” will appear on the display and your current location (latitude/longitude) is shown on the display. (*When the GPS signal receiving from the NMEA 2000 or NEMA-0183, a “**2K**” (NMEA 2000) icon or “**I/O**” (NMEA-0183) icon will appear on the display.)

If there is a problem with the NMEA connection between the radio and the GPS, the GPS icon will blink continuously until the connection is corrected.

The transceiver has a GPS status display which shows the satellites currently being received, along with a graphical (bar-graph) representation of the relative signal strengths from the satellites.

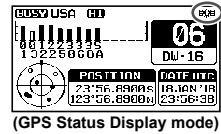

(GPS Status Display mode)

NOTE

When the GPS reception is limited, such as the flush mounting of the radio, it is recommended to connect the optional External GPS Antenna SCU-38 to the GPS connector on the rear panel.

1. Press the [**MENU/SET**] key to display “**MENU**”.
2. Rotate the **DIAL/ENT** knob to select “**GPS**”, then press the [**SELECT**] soft key.
3. Rotate the **DIAL/ENT** knob to select “**GPS STATUS**”, then press the [**ENTER**] soft key to display the GPS status currently being received.
4. Press the [**CLEAR**] key to return to radio operation.

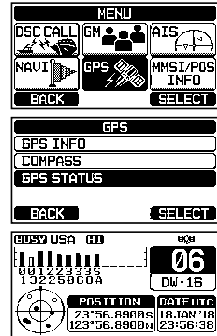

NOTE

For the transceiver to properly show the GPS status page when an external GPS receiver or a chart plotter is connected, the external device must be setup to output GSA and GSV NMEA 0183 sentences. When using the equipment of NMEA 2000, it must be able to output PGN No.129540 (GNSS Sats in View).

8.8 GPS CONFIGURATION

8.8.1 Setting the GPS Time

The transceiver shows GPS satellite time or UTC (Universal Time Coordinated) time in factory default. A time offset is needed to show the local time in your area. The time offset must be changed in order for the radio to display the current time in your area.

1. Press and hold the **[MENU/SET]** key.
2. Rotate the **DIAL/ENT** knob to select “**GPS SETUP**”, then press the **[SELECT]** soft key.
3. Rotate the **DIAL/ENT** knob to select “**TIME OFFSET**”, then press the **[SELECT]** soft key.
4. Rotate the **DIAL/ENT** knob to select time offset of your location. If “00:00” is assigned, the time is the same as UTC or GPS satellite time.
5. Press the **[ENTER]** soft key to store the time offset.
6. Press the **[CLEAR]** key to return to radio operation.

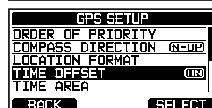
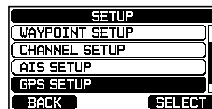

8.8.2 Setting the Time Area

This menu selection allows the transceiver to show UTC time or local time with the offset.

1. Press and hold the **[MENU/SET]** key.
2. Rotate the **DIAL/ENT** knob to select “**GPS SETUP**”, then press the **[SELECT]** soft key.
3. Rotate the **DIAL/ENT** knob to select “**TIME AREA**”, then press the **[SELECT]** soft key.
4. Rotate the **DIAL/ENT** knob to select “**UTC**” or “**LOCAL**”.
5. Press the **[ENTER]** soft key to store the selected setting.
6. Press the **[CLEAR]** key to return to radio operation.

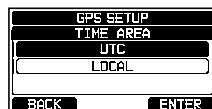
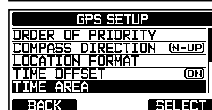
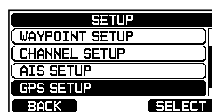

8.8.3 Setting the Time Format

This menu selection allows the transceiver to be setup to show time in 12-hour or 24-hour format.

1. Press and hold the **[MENU/SET]** key.
2. Rotate the **DIAL/ENT** knob to select “GPS SETUP”, then press the **[SELECT]** soft key.
3. Rotate the **DIAL/ENT** knob to select “TIME FORMAT”, then press the **[SELECT]** soft key.
4. Rotate the **DIAL/ENT** knob to select “24hour” or “12hour”.
5. Press the **[ENTER]** soft key to store the selected setting.
6. Press the **[CLEAR]** key to return to radio operation.

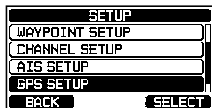

8.8.4 Setting COG to True or Magnetic

The GPS COG (Course Over Ground) and the BRG from a Waypoint Target magnetic variation may be selected to show in ON or OFF. Factory default is “OFF” however by following the steps below the COG can be changed to “ON”.

1. Press and hold the **[MENU/SET]** key.
2. Rotate the **DIAL/ENT** knob to select “GPS SETUP”, then press the **[SELECT]** soft key.
3. Rotate the **DIAL/ENT** knob to select “MAGNETIC VARIATION”, then press the **[SELECT]** soft key.
4. Rotate the **DIAL/ENT** knob to select “OFF” or “ON”.
5. Press the **[ENTER]** soft key to store the selected setting.
6. Press the **[CLEAR]** key to return to radio operation.

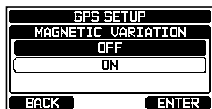
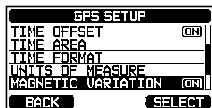



NOTE

The “ON” setting is effective only when the RMC sentences with magnetic data are input from external devices such as a GPS Chart Plotter.

9 BASIC OPERATION

9.1 TURNING THE TRANSCEIVER ON AND OFF

1. After the transceiver has been installed, ensure that the power supply and antenna are properly connected.
2. Press and hold the  key to turn the radio ON.
3. Press and hold the  key again to turn the radio OFF.

9.2 RECEPTION

1. Rotate the **SQL** knob fully counterclockwise. This state is known as “squelch off”.
2. Turn up the **VOL** knob until noise or audio from the speaker is at a comfortable level.
3. Rotate the **SQL** knob, clockwise until the random noise disappears. This state is known as the “squelch threshold”.
4. Rotate the **DIAL/ENT** knob to select the desired channel. Refer to the channel chart on page 129 for available channels.
5. When a signal is received, adjust the volume to the desired listening level. The **BUSY** Indicator Lamp glows green, and the “**BUSY**” indicator on the display indicates that communications are being received.

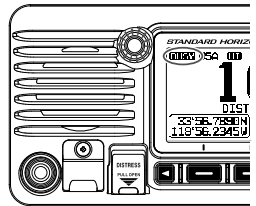

9.3 TRANSMISSION

1. Perform steps 1 through 4 of RECEPTION.
2. Before transmitting, monitor the channel to ensure it is clear.

THIS IS AN FCC REQUIREMENT!

3. Press the microphone's **PTT** (push-to-talk) switch. The “**TX**” indicator on the LCD is displayed.
4. Speak slowly and clearly into the microphone.
5. When the transmission is finished, release the microphone **PTT** switch.

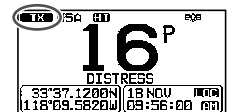

NOTE

Position your mouth about 2cm away from the microphone and speak in a normal voice.

9.3.1 Transmit Power

The TX output power of the transceiver is set to high (25W) in factory default, and the “HI” indicator is displayed on the top part of the screen.

To switch the TX output power:

1. Press the [H/L] key on the front panel or the microphone to switch between HI (25W) or LO (1W) output power.



NOTE: When the TX output power is set to “Low” while the transceiver is on channel 13 or 67 (USA Channel group only), the output power will temporarily switch from “Low” to “High” power until the PTT switch of the microphone is released. This soft key is not function on transmit inhibited and low power only channels.



9.4 BASIC OPERATION OF THE SETUP MENU

Using the setup menu, the various functions of the transceiver can be customized to match the user’s needs and preferences. Items to be adjusted may be selected from the respective lists and the appropriate settings made for the various intended operations.

1. Press and hold the [MENU/SET] key on the operation mode screen.
2. Rotate the DIAL/ENT knob to select the function item, then press the [SELECT] soft key.
3. Rotate the DIAL/ENT knob to select the setting item, then press the [SELECT] soft key.
4. Rotate the DIAL/ENT knob to select the desired setting.
5. Press the [ENTER] soft key to store the selected setting.
6. Press the [CLEAR] key to return to radio operation. (The display can also be returned to the previous screen by pressing the [BACK] soft key.)

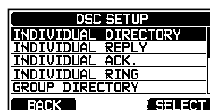
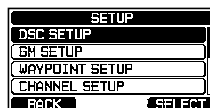

The above process is used when making the Setup Menu adjustments that follow in this Operating Manual.

Press & hold [] ⇒ “DSC SETUP” ⇒ “INDIVIDUAL DIRECTORY”

9.5 TRANSMIT TIME-OUT TIMER (TOT)

When the **PTT** switch on the microphone is held down, transmit time is limited to 5 minutes. This limits unintentional transmissions due to a stuck microphone. About 10 seconds before automatic transmitter shutdown, a warning beep will be heard from the speaker(s). The transceiver will automatically go to receive mode, even if the **PTT** switch is continually held down. Before transmitting again, the **PTT** switch must first be released and then pressed again.

NOTE

Once the transmitter is shut down by the TOT, transmission on the channel is only allowed 10 seconds after the shutdown.

9.6 SIMPLEX/DUPLEX CHANNEL USE

Refer to the **VHF MARINE CHANNEL CHART** (Page 129) for instructions on use of simplex and duplex channels.

NOTE

All channels are factory-programmed in accordance with FCC (USA), ISED (Canada), and International and region regulations. Mode of operation cannot be altered from simplex to duplex or vice-versa.

9.7 CHANNEL GROUP

Set the Channel Group according to the region:

1. Press & hold [] ⇒ **“CHANNEL SETUP”** ⇒ **“CHANNEL GROUP”**
2. Rotate the **DIAL/ENT** knob to select the desired channel group **“USA”**, **“INTL”**, or **“CAN”**.
3. Press the [**ENTER**] soft key to store the selected setting.
4. Press the [**CLEAR**] key to return to radio operation.



Refer to the **“23 CHANNEL ASSIGNMENTS”** (page 129) for allocated channels in each mode.

9.8 NOAA WEATHER CHANNELS

1. To receive a NOAA weather channel, press one of the soft keys, then press the [◀] or [▶] key repeatedly until the [WX] soft key is displayed at the bottom of the screen.



2. Press the [WX] soft key.

The “WX” indicator appears on the top part of the screen.

NOTE: To receive a NOAA weather channel, assign the “WX” command into one of the soft keys, refer to section “16.8 SOFT KEYS”.

3. Rotate the **DIAL/ENT** knob to select a different NOAA weather channel.

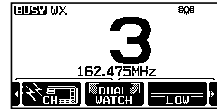

4. To exit from the NOAA weather channels, press one of the soft keys, then press the [CH] soft key. The transceiver returns to the channel it was on prior to a weather channel and the “WX” indicator disappears from the display.

9.8.1 NOAA Weather Alert

In the event of extreme weather disturbances, such as storms and hurricanes, the NOAA (National Oceanic and Atmospheric Administration) sends a weather alert accompanied by a 1050Hz tone and transmits a subsequent weather report on one of the NOAA weather channels.

The **GX2410GPS** can receive weather alerts when monitoring a weather channel and on the last selected weather channel during scanning modes or while monitoring a working channel.

To enable the weather alert function, refer to section “17.2 WEATHER ALERT”.

When an alert is received on a NOAA weather channel, scanning will stop and the transceiver will emit a loud beep to alert the user of a NOAA broadcast. Press any key to stop the alert. After stopping the beep sound, the weather alert reception confirmation screen will appear. Press [OK] to display a confirmation screen. The confirmation screen will ask you whether to move to the weather channel or return in the marine channel. Press [YES] to switch to the weather channel, and press [NO] to return to the marine channel.

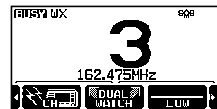

NOTE

If no key is pressed the alert will sound for 5 minutes and then the weather report will be received.

9.8.2 NOAA Weather Alert Testing

NOAA tests the alert system every Wednesday between 11AM and 1PM. To test the NOAA weather feature, setup the transceiver as in section “9.8.1 NOAA Weather Alert” and confirm the alert is heard on Wednesdays between 11AM and 1PM local time.

9.9 MULTI WATCH (TO PRIORITY CHANNEL)

Multi watch is used to scan two or three channels for communications.

- In Dual Watch, a normal VHF channel and the priority channel are scanned alternately.
- In Triple Watch, a normal VHF channel, the priority channel, and the sub channel are scanned alternately.

When a signal is received on the normal channel the radio briefly switches between the normal channel and the priority channel to look for a transmission. If the radio receives communications on the priority channel the radio stops and listens to priority channel until communication ends and then starts dual or triple watch scan again.

9.9.1 Setup the Multi Watch Operation

1. Press & hold [] ⇒ “CHANNEL SETUP” ⇒ “MULTI WATCH”

2. Rotate the **DIAL/ENT** knob to select “**DUAL**” or “**TRIPLE**”.
3. Press the [ENTER] soft key to store the selected setting.
4. Press the [CLEAR] key to return to radio operation.

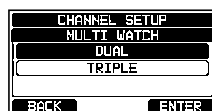

9.9.2 Starting Dual Watch

1. Adjust the **SQL** knob until the background noise disappears.
2. Rotate the **DIAL/ENT** knob to select a channel you wish to watch.
3. Press one of the soft keys.
4. Press [◀] or [▶] key repeatedly until the [DUAL WATCH] soft key is displayed at the bottom of the screen, press the [DUAL WATCH] soft key.



The radio will monitor the priority channel and the channel that was selected in step 2. If a signal is received on the channel selected in step 2, the transceiver will dual watch to priority channel.

5. To stop dual watch, press the [DUAL WATCH] soft key again.

When selecting “**TRIPLE**” in the SETUP menu, [TRI WATCH] will be displayed as the soft key instead of [DUAL WATCH].

NOTE

The priority channel or the sub channel may be changed from CH16 (default) or CH9 (default) to another channel. Refer to section “17.7 PRIORITY CHANNEL” or “17.8 SUB CHANNEL”.

9.10 SCANNING

The transceiver will automatically scan channels programmed into the preset channel memory and also the scan channel memory, and the last selected weather channel.

When an incoming signal is detected on one of the channels during scan, the radio will pause on that channel, allowing you to listen to the incoming transmission. The radio will automatically start scanning again after the transmission stops.

9.10.1 Selecting Scan Type

1. Press & hold [] ⇒ “CHANNEL SETUP” ⇒ “SCAN TYPE”

2. Rotate the **DIAL/ENT** knob to select “**PRIORITY**” or “**MEMORY**”.
3. Press the [ENTER] soft key to store the selected setting.
4. Press the [CLEAR] key to return to radio operation.

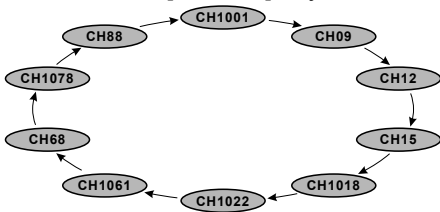
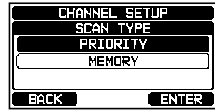

Memory Scan (M-SCAN)

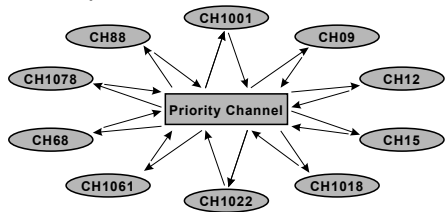

Priority Scan (P-SCAN)

9.10.2 Programming Scan Memory

1. Press & hold [] ⇒ “CHANNEL SETUP” ⇒ “SCAN MEMORY”

2. Rotate the **DIAL/ENT** knob to select a desired channel to be scanned, then press the [MEM] soft key. The “**ON**” icon will appear at the right side of the selected channel.
3. Repeat step 2 for all the desired channels to be scanned.



- To REMOVE a channel from the list, select the channel then press the [MEM] soft key. The “ON” icon of the selected channel will disappear.
- When you have completed your selection, press the [CLEAR] key to return to radio operation.

To check the channels to be scanned, rotate the DIAL. ENT knob. The “MEM” icon will appear when the memory channel is displayed.



NOTE: When “SCAN MEMORY” is assigned to the soft key, the memory function switches between ON and OFF each time the [MEM] soft key is pressed.

9.10.3 Memory Scanning (M-SCAN)

- Set the scan type to “MEMORY” in the SETUP menu (refer to “9.10.1 Selecting Scan Type”).
- Adjust the **SQL** knob until the background noise disappears.
- Press one of the soft keys.
- Press the [◀] or [▶] key repeatedly, then press the [SCAN] soft key. The “MEM SCAN” icon appears on the display. Scanning will proceed from the lowest to the highest programmed channel number and the preset channel (described in the next section). Scanning will stop on a channel when a transmission is received.



The channel number will blink during reception.

- To stop scanning, press the [SCAN] soft key, [16/S] or [CLEAR] key.

9.10.4 Priority Scanning (P-SCAN)

- Set the scan type to “PRIORITY” in the SETUP menu (refer to “9.10.1 Selecting Scan Type”).
- Adjust the **SQL** knob until the background noise disappears.
- Press one of the soft keys.
- Press the [◀] or [▶] key repeatedly, then press the [SCAN] soft key. The “PRI SCAN” icon appears on the display. Scanning will proceed between the memorized channels, the preset channel (described in next section) and the priority channel.

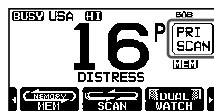

The priority channel will be scanned after each programmed channel.

- To stop scanning, press the [SCAN] soft key, [16/S] or [CLEAR] key.

NOTE

In the default setting, Channel 16 is set as the priority channel. You may change the priority channel from Channel 16 to another desired channel using the SETUP menu. Refer to section “17.7 PRIORITY CHANNEL”.

9.11 PRESET CHANNELS: INSTANT ACCESS

10 preset channels can be programmed for instant access. Pressing the [PRESET] soft key activates the user assigned channel bank. If the [PRESET] soft key is pressed and no channels have been assigned, an error beep will sound.

Before beginning the Instant Access operation, assign the “PRESET” command into one of the programmable keys, refer to section “16.8 SOFT KEYS”.

9.11.1 Programming

1. Rotate the **DIAL/ENT** knob to select the channel to be programmed.
2. Press one of the soft keys.
3. Press the [◀] or [▶] key repeatedly, until the [PRESET] soft key is displayed, then press and hold the [PRESET] soft key until the “P-SET” icon and channel number are blinking.
4. Press the [ADD] soft key to program the channel into the preset channel memory. The “P-SET” icon will appear.
5. Repeat steps 1 through 3 to program the desired channels into the preset channels. Up to 10 channels can be registered. If you attempt to register the 11th channel, an error beep will sound.

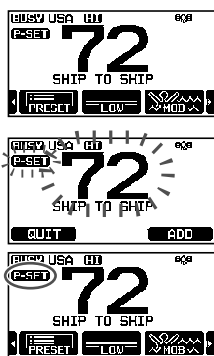

9.11.2 Operation

1. Press one of the soft keys.
2. Press the [◀] or [▶] key repeatedly, then press the [PRESET] soft key to recall the preset channel. The “P-SET” icon will appear on the display.
3. Rotate the **DIAL/ENT** knob to select the desired preset channel.
4. Press the [PRESET] soft key to return to the last selected channel. The “P-SET” icon will disappear from the display.

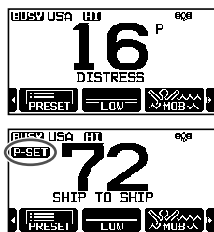

9.11.3 Deletion

1. Press one of the soft keys.
2. Press the [◀] or [▶] key repeatedly, then press the [P-SET] soft key to recall the preset channel



3. Rotate the **DIAL/ENT** knob to select the preset channel to be deleted.
4. Press one of the soft keys, then press and hold the [PRESET] soft key until the “P-SET” icon and channel number are blinking.
5. Press the [DELETE] soft key to delete the channel from the preset channel memory.
6. Repeat steps 3 through 5 to delete the undesired channels from preset channels.
7. To exit from deleting the preset channels, press the [QUIT] soft key.



9.12 MOB OPERATION

The **GX2410** provides a feature to memorize the position information instantly in case of MOB (Man Over-Board).

1. Press one of the soft keys.
2. Press the [◀] or [▶] key repeatedly, then press the [MOB] soft key.
3. Press the [TO WPT] soft key to start the navigation to the displayed position. For details about the navigation, see section “12 NAVIGATION”.
4. To change the displayed position information, press the [POS/TM] soft key. For details about modification of the position, see “Editing a Waypoint” on page 78.
5. To transmit a DSC distress message, lift the red spring loaded DISTRESS cover on the right side of the transceiver, then press and hold the **DISTRESS** key (see section “11.2.1 Transmitting a Distress Alert” for details).

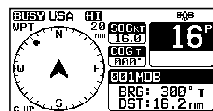
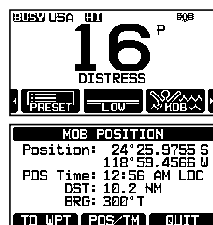

9.13 PA/FOG OPERATION

The **GX2410** has 30 W hailer built-in and can be used with any 4 Ohm PA horn. Standard Horizon offers two HAIL/PA horns, the **220SW** (5" round 30 Watt HAIL/PA horn) and the **240SW** (5" x 8" rectangular 40 Watt HAIL/PA horn). When the **GX2410** is in PA Hail mode the PA speaker listens back (acts as a microphone and provides two-way communications through the HAIL/PA horn to the main radio).

NOTE

When in the PA HAIL or FOG HORN mode, the **GX2410** will continue to receive DSC calls and communications on the last selected working channel prior to entering the PA HAIL or FOG HORN mode. Then the **GX2410** AIS page can also be accessed when in the PA HAIL or FOG HORN mode.

PA HAIL mode:

PA HAIL mode allows the transceiver to be used as a power hailer when an optional STANDARD HORIZON **220SW** or **240SW** HAIL/PA horn is installed. The PA Hail mode has a listen-back feature which provides two way communication through the HAIL/PA horn.

FOG HORN mode:

Automatic signaling is transmitted through the HAIL/PA horn. When the fog horn signal is not being outputted the **GX2410** listens back through the connected HAIL/PA horn.

HORN mode:

Foghorn sound or siren sound can be transmitted through the HAIL/PA horn. When the fog horn signal is not being outputted the **GX2410** listens back through the connected HAIL/PA horn.

9.13.1 Operating the PA HAIL mode

1. Press one of the soft keys.
2. Press the [◀] or [▶] key repeatedly, then press the [PA] soft key.
3. Press the microphone's PTT switch to speak through the HAIL/PA speaker.
4. Press the [PA VOL] soft key, then rotate the DIAL/ENT knob to control the AF output level. Press the [ENTER] soft key. The AF output level can be set from 0 to 31.
5. To listen back, rotate the VOL knob.
6. Press the [CLEAR] key to return to radio operation.

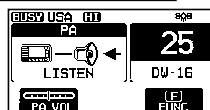

9.13.2 Operating the FOG HORN mode

The user can select the type of horn from “Underway”, “Stop”, “Sail”, “Towing”, “Aground”, “Anchor”, “Horn”, and “Siren”.

1. Press one of the soft keys.
2. Press the [◀] or [▶] key repeatedly, then press the [FOG HORN] soft key.
3. Rotate the **DIAL/ENT** knob to select one of the eight functions described above, then press the [SELECT] soft key.
4. Press the [FOG VOL] soft key, then rotate the **DIAL/ENT** knob to control the AF output level. Press the [ENTER] soft key. The AF output level can be set from 0 to 31.
5. On the “HORN” and “SIREN” modes, press the [HORN] soft key to activate the tone through the HAIL/PA speaker. Press the [HORN VOL] soft key, then rotate the **DIAL/ENT** knob to control the AF output level. Press the [ENTER] soft key. The AF output level can be set from 0 to 31.
6. To listen back, rotate the **VOL** knob.
7. Press the [CLEAR] key to return to radio operation.

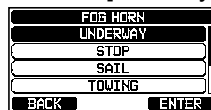

9.13.3 Fog Signal Timing Chart

TYPE	PATTERN	USAGE
UNDERWAY	One 5-second blasts every 120 seconds. 	Motor vessel underway and making way.
STOP	Two 5-second blasts (separated by 2 seconds) every 120 seconds. 	Motor vessel underway but stopped (not making way).
SAIL	One 5-second blasts followed by two 1-second blasts (separated by 2 seconds) every 120 seconds. 	Sailing vessel underway, fishing vessel (underway or anchored), vessel not under command, a vessel restricted in her ability to maneuver (underway or at anchor), or a vessel towing or pushing another ahead.
TOWING	One 5-second blasts followed by three 1-second blasts (separated by 2 seconds) every 120 seconds. 	Vessel under tow (manned).

TYPE	PATTERN	USAGE
AGROUND	<p>One 11-second rings every 60 seconds.</p>	Vessel is aground.
ANCHOR	<p>One 5-second rings every 60 seconds.</p>	Vessel is at anchor.

9.14 INTERCOM OPERATION

The optional **SSM-70H (RAM4)** or **SSM-72H (RAM4X)** remote station microphone must be connected to perform intercom functions between the **GX2410** and the **SSM-70H (RAM4)** or **SSM-72H (RAM4X)**.

NOTE

When using the intercom function, connect **SSM-70H (RAM4)** or **SSM-72H (RAM4X)** Remote Station Microphone to the transceiver.

9.14.1 Communication

1. Press one of the soft keys.
2. Press the [◀] or [▶] key repeatedly, then press the [IC] soft key.
3. Rotate the **DIAL/ENT** knob to select the device to which you want to communicate, then press the [SELECT] soft key. The “✓” icon will appear at the left side of the selected station.

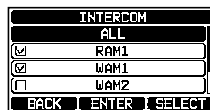

NOTE: When only one **SSM-70H (RAM4)** or **SSM-72H (RAM4X)** is connected to **GX2410**, continue to step 6.

4. Repeat step 3 for all the desired devices.
5. Press the [ENTER] soft key.
6. When the intercom mode is enabled, “**INTERCOM**” is displayed on the radio and **SSM-70H (RAM4)**.



- Press the transceiver microphone PTT switch, “Talk” will be shown on the display.

NOTE: A warning beep will be heard when the transceiver **PTT** and **RAM4 PTT** switches are pushed at the same time.

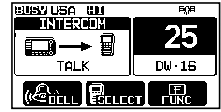

- Speak slowly and clearly into the microphone, hold the microphone about 1.5cm away from your mouth.
- When finished, release the **PTT** switch.
- Press the [**CLEAR**] key to return to radio operation.

9.14.2 Calling

When in intercom mode, pressing the [**BELL**] soft key on either the radio or **RAM4** microphone will produce a calling beep to the other station.

9.15 INTERCOM OPERATION

The optional **SSM-70H (RAM4)** or **SSM-72H (RAM4X)** remote station microphone must be connected to perform intercom functions between the **GX2410** and the **SSM-70H (RAM4)** or **SSM-72H (RAM4X)**.

NOTE

When using the intercom function, connect one **SSM-70H (RAM4)** or **SSM-72H (RAM4X)** Remote Station Microphone to the **GX2410**.

9.15.1 Communication

- [] ⇒ “IC”

- Rotate the **DIAL/ENT** knob to select the device to which you want to communicate, then press the [**SELECT**] soft key. The “✓” icon will appear at the left side of the selected station.



NOTE: When only one **SSM-70H (RAM4)** is connected to **GX2410**, continue to step 5.

- Repeat step 2 for all the desired devices.
- Press the [**ENTER**] soft key.
- When the intercom mode is enabled, “**INTERCOM**” is displayed on the radio and **SSM-70H (RAM4)**.
- Press the microphone’s **PTT** switch on the radio. “Talk” will be shown on the display.



NOTE: A warning beep will be heard when the radio’s **PTT** and **RAM4**’s **PTT** switches are pushed at the same time.

- Speak slowly and clearly into the microphone, hold the microphone about 1/2” (1.5cm) away from your mouth.

8. When finished, release the **PTT** switch.
9. Press the **CLEAR** key to return to radio operation.

9.15.2 Calling

Pressing the [**BELL**] soft key when in intercom mode on either the radio or **RAM4** microphone will produce a calling beep to the other station.

9.16 VOICE SCRAMBLER

The voice scrambler function may only be enabled by your dealer. The 4-code type (CVS2500A compatible) or the 32-code type (FVP-42 corresponding to Furuno Electric M-4721), voice scrambler can be enabled in the CHANNEL FUNCTION SETUP menu.

NOTE

The voice scrambler function is not available with the factory default settings. Please contact your dealer to activate the voice scrambler function.

1. Select a channel that was programmed for scrambler mode (the “

9.17 DEMO MODE

This mode is used by Standard Horizon sales persons and dealers to demonstrate the transceiver’s DSC functions. Demo mode allows latitude, longitude and time to be entered manually to simulate the displays. When the demo mode is enabled, the transceiver will automatically switch from the NORMAL, COMPASS, WAYPOINT and GM displays.

NOTE

When demo mode is enabled, if the transceiver is turned OFF and back ON it will still be in the demo mode.

1. Press & hold [] ⇒ **“ABOUT...”** ⇒ **“DEMO OPERATION”**
2. Rotate the **DIAL/ENT** knob to select **“DEMO POSITION INPUT”**, then press the [**SELECT**] soft key.

3. Enter the latitude and longitude of your vessel and your local UTC time in the 24-hour notation. Press the [◀] or [▶] key to select the number and press the [SELECT] soft key to move the cursor to the next character.
4. If a mistake is made while entering the latitude, longitude or local UTC time of your vessel, you can use the [◀] or [▶] key to select “←” or “→”, press the [SELECT] soft key until the incorrect character is selected, then perform step 2 to make the correction.
5. To store the data entered, press the [FINISH] soft key.
6. Rotate the **DIAL/ENT** knob to select “**DEMO START**”, then press the [SELECT] soft key.
7. Rotate the **DIAL/ENT** knob to select “**START**”, then press the [ENTER] soft key.



NOTE

To exit the demo mode, select “**STOP**” in step 7 above.

10 GPS OPERATION

The **GX2410** has an internal GPS receiver to acquire and display the satellite position information*. When the radio is connected to an external GPS device by the NMEA-0183 or NMEA2000, you may select the order of priority of the connection devices to be used when obtaining location information via the SETUP menu (Refer to section “**19.1 ORDER OF PRIORITY**”). Your position information as well as received positions can be memorized and utilized later for navigation.

10.1 DISPLAYING POSITION INFORMATION

10.1.1 GPS Information Numerical Display

1. [] → “GPS” → “GPS INFO”

2. The numerical data is displayed.
3. Press the [CLEAR] key to return to radio operation.

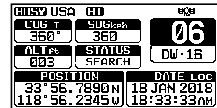

10.1.2 GPS Information Compass Display

1. [] → “GPS” → “COMPASS”

2. The compass data is displayed.
3. Press the [CLEAR] key to return to radio operation.
NOTE: Depending on the assignment of the soft keys you may switch the screen immediately from the basic display to the compass display by pressing the [COMP] soft key.

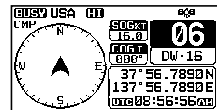

10.2 CHECKING GPS STATUS

1. [] → “GPS” → “GPS STATUS”

2. Display the GPS status currently being received.
3. Press the [CLEAR] key to return to radio operation.

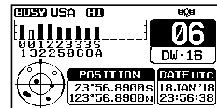

10.3 GPS LOGGER OPERATION

The **GX2410** includes a logger for position information that allows you to record your location at regular intervals.

1. Press one of the soft keys.
2. Press the [◀] or [▶] key repeatedly, then press the [LOGGER] soft key to turn the function on or off.



The recording starts and the display returns to the previous screen with the “📍” icon on the top of the display.

- You may change the log interval time of recording via the SETUP menu (Refer to section “19.10.4 Logger Interval”).

NOTE: To utilize the records, connect the **GX2410** to a PC and download the log data from the radio by using the PC Programming Software. Refer to section “21 CONNECTING A USB DATA TERMINAL TO THE PC”.

Logger operation alert:

- When the memory for log data becomes full, three beeps will sound and a warning message will be displayed. Afterwards the logger does not operate until the log data in the memory are erased.
- When the logger cannot record for some reason, three beeps will sound and a warning message will be displayed. Afterwards the logger does not operate anymore.
- An error message will be displayed when the radio cannot erase the log data in the memory during the operation following the alert of memory full (see above) or in the SETUP menu (Refer to section “19.10.5 Log Erase”).

11 DIGITAL SELECTIVE CALLING (DSC)

11.1 GENERAL

WARNING

This **GX2410** is designed to generate a digital maritime distress and safety call to facilitate search and rescue. To be effective as a safety device, this equipment must be used only within communication range of a shore-based VHF marine channel 70 distress and safety watch system. The range of signal may vary but under normal conditions should be approximately 20 nautical miles.

Digital Selective Calling (DSC) is a semi-automated method of establishing a radio call, it has been designated by the International Maritime Organization (IMO) as an international standard for establishing VHF, MF and HF radio calls. It has also been designated as part of the Global Maritime Distress and Safety System (GMDSS). It is planned that DSC will eventually replace aural watches on distress frequencies and will be used to announce routine and urgent maritime safety information broadcasts.

This system allows mariners to instantly send a distress call with its own position, to the Coast Guard and other vessels within range of the transmission. DSC will also allow mariners to initiate or receive Distress, Urgency, Safety, Routine, Position Request, Position Report, Automatic Position Polling, and Group calls to or from another vessel equipped with a DSC transceiver.

11.2 DISTRESS ALERT

The **GX2410** is capable of transmitting and receiving DSC distress messages. Distress alerts transmitted from the transceiver include the latitude and longitude of the vessel when valid GPS position data is being received.

11.2.1 Transmitting a Distress Alert

NOTE

To be able to transmit a DSC distress alert, the MMSI number must be programmed, refer to section “**8.6.1 Maritime Mobile Service Identity (MMSI)**”.

In order for the ships location to be transmitted, the **GX2410** must receive valid position data from the internal GPS receiver or another GPS device connected with a NMEA 0183 or NEMA 2000 network. Refer to section “**8.5.2 Accessory Cables**”.

Basic Operation

1. Lift the red spring loaded **[DISTRESS]** cover, then press and hold the **[DISTRESS]** key for 3 seconds. The radio display will count down (3-2-1) and then transmit the distress alert. The backlight of the display and keypad flashes while the radio's display is counting down.
2. When the distress signal is sent, the transceiver watches for a transmission on CH70 until an acknowledgment signal (distress acknowledgement) is received.
3. If no acknowledgment is received, the distress alert is repeated in 4-minute intervals until an acknowledgment is received.
4. When a distress acknowledgment is received, a distress alarm sounds and Channel 16 is automatically selected. The display shows the MMSI of the ship responding to your distress.
5. Press the microphone **PTT** switch and state your name, vessel name, number of persons on board and the distress situation, then say **“over”** and wait for a reply from the acknowledging ship.
6. To turn the distress alarm OFF before the radio retransmits the distress alert, press the **[16/S]** key or the **[QUIT]** soft key.

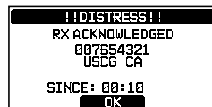
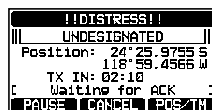
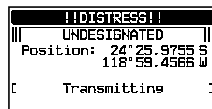
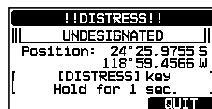

Transmitting a Distress Alert with Nature of Distress

The transceiver is capable of transmitting a distress alert with the following “Nature of Distress” categories:

Undesignated, Fire/Explosion, Flooding, Collision, Grounding, Capsizing, Sinking, Adrift, Abandoning, Piracy, MOB.

1.  **“DSC CALL”** **“DIST ALERT MSG”**
2. Press the **[NATURE]** soft key. The **“NATURE OF”** menu will appear on the display.
3. Rotate the **DIAL/ENT** knob to select the desired nature of distress category, then press the **[SELECT]** soft key.
4. Press and hold the **DISTRESS** key until a distress alert is transmitted.

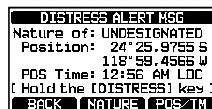

Transmitting a Distress Alert by Manually Inputting Location and Time

In case the transceiver fails to get a GPS position fix, you may manually input the latitude, longitude and time before transmitting the distress alert.

1. [] ⇒ “DSC CALL” ⇒ “DIST ALERT MSG”

2. Press the [POS/TM] soft key.

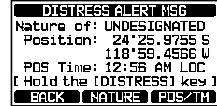

```

DISTRESS ALERT MSG
Nature of: UNDESIGNATED
Position: 24°25.9755 S
          118°58.4566 W
POS Time: 12:29 AM LOC
[ Hold the [DISTRESS1] key ]
[BACK] [NATURE] [POS/TM]

```

3. Press the [◀] or [▶] key to select the first number of the latitude, then press the [SELECT] soft key to step to the next number.



```

POSITION/TIME
Lat: 04°25.9755 S
Lon: 118°58.4566 E
Time: 12:29 AM LOC
|1|2|3|4|5|6|7|8|9|0|S|N|
|<|>|Delete|
[BACK] [FINISH] [SELECT]

```

4. Repeat step 3 to set the position and time.

If a mistake is made, press the [◀] or [▶] key to select “←” or “→”, press the [SELECT] soft key until the incorrect character is selected, then perform step 3.

5. When finished programming the position and time, press the [FINISH] soft key. The display will return to the previous screen.

6. Press and hold the [DISTRESS] key until a distress alert is transmitted.

Pausing a Distress Alert

After a distress alert is transmitted, the distress alert is repeated every 4 minutes until the call is canceled by the user or until the radio is turned OFF and ON again. The transceiver has the capability to suspend (pause) the retransmitting of the distress alert by the procedure below.

1. After the distress alert is transmitted, the radio will show the display as on the right.

Looking at this display you will notice “TX IN: 02:10”, this is the time when the radio will re-transmit the distress alert.

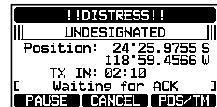

```

!!DISTRESS!!
UNDESIGNATED
Position: 24°25.9755 S
          118°58.4566 W
TX IN: 02:10
[ Waiting for ACK ]
[PAUSE] [CANCEL] [POS/TM]

```

2. To suspend re-transmitting the distress alert call, press the [PAUSE] soft key.

3. To resume counting down to transmit the distress alert, press the [RESUME] soft key.

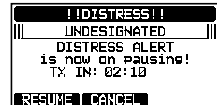

```

!!DISTRESS!!
UNDESIGNATED
DISTRESS ALERT
is now on pausing!
TX IN: 02:10
[RESUME] [CANCEL]

```

Canceling a Distress Alert

If a distress alert was sent by error, the transceiver allows you to send a message to other vessels to cancel the distress alert that was made.

1. Press the **[CANCEL]** soft key, then press the **[YES]** soft key.
2. After the message for canceling has been transmitted, press the **[OK]** soft key.
3. Press the **[FINISH]** soft key.
4. Press the **[QUIT]** soft key to return to radio operation.

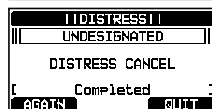
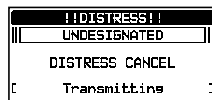
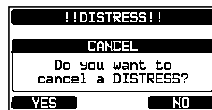

11.2.2 Receiving a Distress Alert

1. When a distress alert is received, an emergency alarm sounds.
2. Press any key to stop the alarm.
3. Rotate the **DIAL/ENT** knob to show information on the vessel in distress.
On the display you will notice 3 soft key selections.

These selections are described below:

[ACCEPT]: Press this key to accept the distress alert and switch to Channel 16.

NOTE: If a key is not pressed within 30* seconds the radio will automatically switch to Channel 16. *(**"AUTO CHANNEL CHANGE"** timer settings can be changed in "DSC SETUP" menu. The default setting is 30 sec.)

[PAUSE]: Press this key to temporarily pause automatic switching to Channel 16.

[QUIT]: Press this key to end quit the automatic Channel 16 switching and revert to the last selected working channel.

4. After accepting the call, press the **[TO WPT]** soft key to set the location of the vessel in distress as a destination for navigation.

NOTE: You may change the waypoint name.

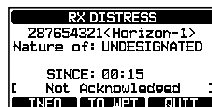
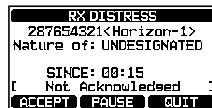
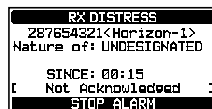

- Rotate the **DIAL/ENT** knob to select “**SAVE & GOTO**”, then press the **[SELECT]** soft key to change the display to the waypoint navigation screen. The display indicates the distance and direction of the vessel in distress, and the compass displays the distressed vessel with a dot (●).
- To stop navigating to a waypoint, press one of the soft keys, then press the **[STOP]** soft key. The radio is switched to the normal mode.

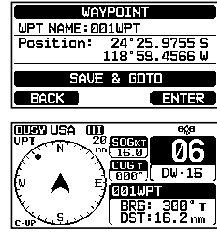

NOTE

- You must continue monitoring Channel 16 as a coast station may require assistance in the rescue attempt.
- When there is an unread distress alert, an “” icon will appear on the display. You may review the unread distress alert from the DSC log, refer to section “**11.10.2 Reviewing a Logged DSC RX Distress Alert and acknowledgement**”.

11.3 ALL SHIPS CALL

The all ships call function allows contact to be established with DSC equipped vessels without having their MMSI in the individual calling directory. Also, priority for the call can be designated as “**SAFETY**” or “**URGENCY**”.

SAFETY Call: This type of DSC call is used to transmit boating safety information to other vessels. This message usually contains information about an overdue boat, debris in the water, loss of a navigation aid or an important meteorological message. This call is the same as transmitting “Securite, Securite, Securite” by voice.

URGENCY Call: This type of call is used when a vessel may not truly be in distress, but have a potential problem that may lead to a distress situation. This call is the same as transmitting “PAN PAN, PAN PAN, PAN PAN” on Channel 16.

11.3.1 Transmitting an All Ships Call

- [MENU / SET]** → “**DSC CALL**” → “**ALL SHIPS**”

- Rotate the **DIAL/ENT** knob to select the nature of the call (“**SAFETY**” or “**URGENCY**”), then press the **[SELECT]** soft key.



3. In the INTERSHIP CH list, rotate the **DIAL/ENT** knob to select the operating channel on which you want to communicate, then press the [**SELECT**] soft key. To select operating channels from all voice channels, press the [**MANUAL**] soft key.
4. Press the [**YES**] soft key to transmit the selected type of all ships call.
5. After the all ships call is transmitted, the transceiver will switch to the selected channel.
6. Listen to the channel to make sure it is not busy, then key the microphone and say “PAN PAN, PAN PAN, PAN PAN” or “Securite, Securite, Securite” depending on the priority of the call.
7. Press the [**QUIT**] soft key to exit the all ships call menu.

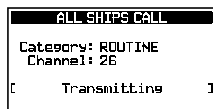
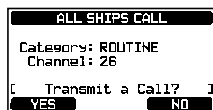
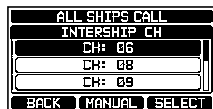

11.3.2 Receiving an All Ships Call

1. When an all ships call is received, an emergency alarm will sound.

The display shows the MMSI of the vessel transmitting the all ships call and the radio will change to the requested channel after 30 seconds (the default setting of “AUTO CHANNEL CHANGE”).

2. Press any key to stop the alarm.
3. Monitor the requested channel until the all ships voice communication is completed.

On the display you will notice 3 soft key selections.

These selections are described below:

[ACCEPT]: Press this key to accept the DSC all ships call and to switch to requested channel.

NOTE: If a key is not pressed for 30* seconds or longer the radio will automatically change to the requested channel.

*(The default setting of “AUTO CHANNEL CHANGE”)

[PAUSE]: Press this key to temporarily pause automatic switching to the requested channel.

NOTE: In some cases, automatically switching to the requested channel might disrupt important ongoing communications. Commercial users may suspend channel switching and remain on the working channel in use before the all ships call was received.

[QUIT]: Press this key to quit the automatic channel switching and revert to the last selected working channel.

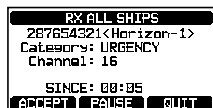

- Press the [QUIT] key to return to the channel display.

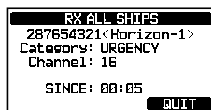

NOTE

When there is an unread all ships call, an “✉” icon will appear on the display. You may review the unread all ships call from the DSC log, refer to section “11.10.2 Reviewing a Logged DSC RX Distress Alert and acknowledgment”.

11.4 INDIVIDUAL CALL

This feature allows the **GX2410** to contact another vessel with a DSC VHF radio and automatically switch the receiving radio to the desired communications channel. This feature is similar to calling a vessel on CH16 and requesting to go to another channel (switching to the channel is private between the two vessels). Up to 100 individual contacts may be programmed.

11.4.1 Setting up the Individual / Position Call Directory

The transceiver has a DSC individual directory that allows storing vessels or persons names and the associated MMSI numbers you may wish to contact via individual calls, auto polling, position request, position report, and polling transmissions. To transmit an individual call, you must program this directory with information of the persons you wish to call, similar to a cellular phone contact list.

- Press & hold [] ⇒ “DSC SETUP” ⇒ “INDIVIDUAL DIRECTORY”

- Rotate the **DIAL/ENT** knob to select “ADD”, then press the [SELECT] soft key.



- Rotate the **DIAL/ENT** knob to select “NAME:”, then press the [SELECT] soft key.

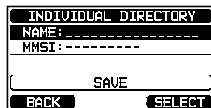

- Press the [◀] or [▶] key to select the letters of the name of the vessel or person you want to reference in the directory.
- Press the [SELECT] soft key to store the first letter in the name and step to the next letter to the right.



6. Repeat steps 4 and 5 until the name is complete. The name can consist of up to fifteen characters, and if you do not use all fifteen characters, select “→” to move to the next space. The “→” can also be used to enter a blank space in the name.
If a mistake is made entering in the name, press the [◀] or [▶] key to select “←” or “→”, press the [SELECT] soft key until the incorrect character is selected, then perform steps 4 and 5.
7. When finished entering the name (using eleven characters or less), press the [FINISH] soft key to advance to the MMSI number entry.
8. Rotate the **DIAL/ENT** knob to select “**MMSI:**”, then press the [SELECT] soft key.
9. Press the [◀] or [▶] key to select numbers, 0 - 9. To enter the desired number and move one space to the right by pressing the [SELECT] soft key. Repeat this procedure until all nine space of the MMSI number are entered. If a mistake is made entering in the MMSI number, press the [◀] or [▶] key to select “←” or “→”, press the [SELECT] soft key until the incorrect character is selected, then perform step 9.
10. When finished entering the MMSI number, press the [FINISH] soft key.
11. To store the entered data, Rotate the **DIAL/ENT** knob to select “**SAVE**”, then press the [ENTER] soft key.
12. To enter another individual address, repeat steps 2 through 11.
13. Press the [CLEAR] key to return to radio operation.



11.4.2 Setting up the Individual Call Reply

This menu item sets up the radio to manually (default setting) or automatically respond to a DSC individual call requesting you to switch to a working channel for voice communications. When “MANUAL” is selected the MMSI of the calling vessel is shown allowing you to see who is calling. This function is similar to caller ID on a cellular phone.

1. Press & hold [] ⇒ “**DSC SETUP**” ⇒ “**INDIVIDUAL REPLY**”
2. Rotate the **DIAL/ENT** knob to select “**AUTO**” or “**MANUAL**”.
3. Press the [ENTER] soft key to store the selected setting.
4. Press the [CLEAR] key to return to radio operation.



11.4.3 Enabling the Individual Call Acknowledgment

The radio can select either reply message “**ABLE**” (default) or “**UNABLE**” when the individual reply setting (described in the previous section) is set to “**AUTOMATIC**”.

1. Press & hold [] ⇒ “**DSC SETUP**” ⇒ “**INDIVIDUAL ACK.**”

2. Rotate the **DIAL/ENT** knob to select “**ABLE**” or “**UNABLE**”.
3. Press the [**ENTER**] soft key to store the selected setting.
4. Press the [**CLEAR**] key to return to radio operation.



11.4.4 Transmitting an Individual Call

This feature allows the user to contact another vessel with a DSC transceiver, and is similar to calling a vessel on CH16 and requesting to go to another channel.

Individual Call using the Individual/Position Directory

1. [] ⇒ “**DSC CALL**” ⇒ “**INDIVIDUAL CALL**”

2. Rotate the **DIAL/ENT** knob to select “**HISTORY**” or “**MEMORY**”, then press the [**SELECT**] soft key.

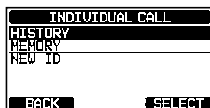

3. Rotate the **DIAL/ENT** knob to select an individual you want to contact, press the [**SELECT**] soft key.



4. In the INTERSHIP CH list, rotate the **DIAL/ENT** knob to select the operating channel on which you want to communicate, then press the [**SELECT**] soft key. To select operating channels from all voice channels, press the [**MANUAL**] soft key.

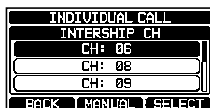

5. Press the [**YES**] soft key to transmit the individual DSC signal.

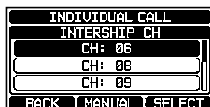

6. When an individual call acknowledgment is received, the operating channel is automatically changed to the channel which is selected in step 4 above and a ringing tone sounds.

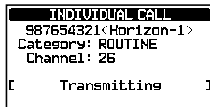

- Press the **[QUIT]** soft key to listen to the channel to make sure it is not busy, then press the microphone **PTT** switch and talk into the microphone to communicate with the other vessel.

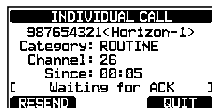

Individual Call by Manually Entering an MMSI

You may enter an MMSI contact number manually without storing it in the individual directory.

- [MENU / SET]** → **"DSC CALL"** → **"INDIVIDUAL CALL"**
- Rotate the **DIAL/ENT** knob to select **"NEW ID"**, then press the **[SELECT]** soft key.
- Press the **[◀]** or **[▶]** key to select the first number of the MMSI which you want to contact, then press the **[SELECT]** soft key to step to the next number.
- Repeat step 3 to set the MMSI number (nine digits). If a mistake is made while entering the MMSI number, press the **[◀]** or **[▶]** key to select "←" or "→", press the **[SELECT]** soft key until the incorrect character is selected, then perform step 3 to enter the corrections.
- When finished entering the MMSI number, press the **[FINISH]** soft key.
- In the INTERSHIP CH list, rotate the **DIAL/ENT** knob to select the operating channel on which you want to communicate, then press the **[SELECT]**. To select operating channels from all voice channels, press the **[MANUAL]** soft key.
- Press the **[YES]** soft key to transmit the individual DSC call.
- When an individual call acknowledgment is received, the operating channel is automatically changed to the channel which is selected in step 6 above and a ringing tone sounds.
- Press the **[QUIT]** soft key to listen to the channel and make sure it is not busy, then press the microphone **PTT** switch and talk into the microphone to communicate with the other vessel.

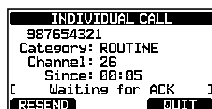
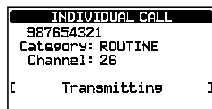
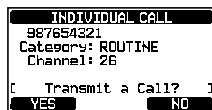
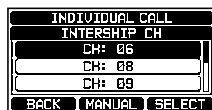
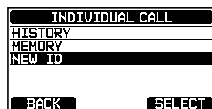

11.4.5 Receiving an Individual Call

When an individual DSC call is received, the MMSI (Maritime Mobile Service Identity Number) or person's name is displayed, you may choose whether or not to send your position to the requesting vessel. Refer to section “**11.4.2 Setting up the Individual Call Reply**” to change the reply to “AUTO” if you want to automatically replying to the call.

Manual reply (Default setting):

1. When an individual call is received, a ringing alarm sounds.

The display shows the MMSI of the vessel transmitting the individual call.



2. Press any key to stop the alarm.
3. The 3 soft key selections shown on the display are described below:

[ACCEPT]: Press this key to accept the DSC individual call, and switch to the requested channel.

[PAUSE]: Press this key to temporarily pause automatically switching to the requested channel.

NOTE: In some cases, automatically switching to a requested channel might disrupt important ongoing communications. Commercial users may suspend channel switching and remain on the working channel in use before the individual call was received.

[QUIT]: Press this key to exit the automatic channel switching and revert to the last selected working channel.

NOTE: If a key is not pressed within 30 seconds, the transceiver will automatically change to radio operation.

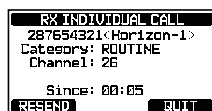

4. After accepting the call, press the **[ABLE]** soft key to switch to the requested channel. (To inform the calling vessel that you are unable to respond, press the **[UNABLE]** soft key.)

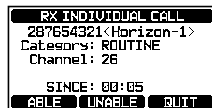

5. Press the **[YES]** soft key to send an acknowledgement. Press the **[CHG CH]** soft key to change to the requested operating channel for communication.

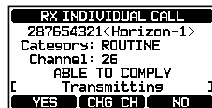

6. Monitor the specified channel until the message is completed. Press the microphone **PTT** switch and talk into the microphone to communicate with the vessel that initiated the individual call.
7. Press the **[QUIT]** soft key to return to the channel display.



Automatic reply:

- When an individual call is received, a ringing alarm sounds.
The radio automatically switches to the requested channel. The display shows the MMSI of the vessel calling.
- Press any key to stop the alarm.
- Monitor the requested channel until the message is completed.
Press the microphone **PTT** switch and talk into the microphone to communicate with the vessel that initiated the individual call.
- Press the **[QUIT]** soft key to return to radio operation.



NOTE

When there is an unread individual call, the “✉” icon will appear on the display. You may review the unread individual call from the DSC log, refer to section “11.10.2 Reviewing a Logged DSC RX Distress Alert and acknowledgement”.

11.4.6 Setting up the Individual Call Ringer

When an individual call is received the call ringer will sound for 2 minutes (default setting). This selection allows the individual call ringer time to be changed.

- Press & hold [] ⇒ “DSC SETUP” ⇒ “INDIVIDUAL RING”
- Rotate the **DIAL/ENT** knob to select the individual call ringing time.
- Press the **[ENTER]** soft key to store the selected setting.
- Press the **[CLEAR]** key to return to radio operation.



The **GX2410** individual call ringer may be set to OFF:

- [Press & hold [] ⇒ “DSC SETUP” ⇒ “DSC BEEP”
- Rotate the **DIAL/ENT** knob to select “**INDIVIDUAL CALL**”, then press the **[SELECT]** soft key.
- Rotate the **DIAL/ENT** knob to select “**OFF**”.
- Press the **[ENTER]** soft key to store the selected setting.
- Press the **[CLEAR]** key to return to radio operation.

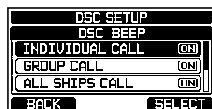

To enable the ringer tone, repeat the above procedure, Rotate the **DIAL/ENT** knob to select “**ON**” in step 3 above.

11.5 GROUP CALL

This feature allows users to automatically contact a specific group of vessels using DSC radios with the group call function. The called radios can automatically switch to the desired channel for voice communications. This function is very useful for yacht clubs and vessels traveling together that want to make communal announcements on a predetermined channel. Up to 30 group MMSIs may be programmed.

11.5.1 Setting up a Group Call

For this function to operate, the same group MMSI (Maritime Mobile Service Identity Number) must be programmed into all the DSC VHF radios within the group of vessels that will be using this feature. To understand Group MMSI programming, first a ship MMSI has to be understood.

Ship MMSI: The first three digits called MID (Mobile Identity Group) of a ship MMSI denote the country where the ship’s MMSI is registered. The last 6 digits are specific to the ships ID.

Ship MMSI Example: If your MMSI is “366123456”, “366” is MID which denote the country and “123456” is the vessel’s MMSI.

Group MMSI:

- Group MMSI numbers are not assigned by the FCC or other organizations licensed to assign ship MMSI numbers.
- The first digit of a group MMSI is always set to “0” by International rules. All Standard Horizon radios are preset so when programming a group MMSI the first digit is set to “0”.
- The ITU (International Telecommunication Union) recommends programming the MID of a ship MMSI into the Second, Third and Fourth digits of the group MMSI as it denotes the area where the ship is located.
- The last 5 digits are decided upon by persons in the group. This is an important step as all radios in the group must contain the same group MMSI in order to be contacted by each other. There is a chance that another group of vessels may program the same group MMSI. If this happens, simply change one or more of the last 5 digits of the group MMSI.

1. [Press & hold [] ⇒ “DSC SETUP” ⇒ “GROUP DIRECTORY”

2. Rotate the **DIAL/ENT** knob to select “**ADD**”, then press the [**SELECT**] soft key.



3. Rotate the **DIAL/ENT** knob to select “**GP NAME:**”, then press the [**SELECT**] soft key.



4. Press the [**◀**] or [**▶**] key to select the first letter of the name of the group you want to reference in the directory.
5. Press the [**SELECT**] soft key to store the first letter of the name and step to the next letter to the right.
6. Repeat steps 4 and 5 until the name is complete. The name can consist of up to fifteen characters, if you do not use all eleven characters, select “**→**” to move to the next space. This method can also be used to enter a blank space in the name.



If a mistake is made entering the name, press the [**◀**] or [**▶**] key to select “**←**” or “**→**”, press the [**SELECT**] soft key until the incorrect character is selected, then perform steps 4 and 5.

7. When finished entering the group name (using fifteen characters or less), press the [**FINISH**] soft key to advance to the group MMSI number entry.
8. Rotate the **DIAL/ENT** knob to select “**GP MMSI:**”, then press the [**SELECT**] soft key.



9. Press the [**◀**] or [**▶**] key to select the second number of the MMSI (the first of the nine digits is permanently set to “0”) which you want to contact, then press the [**SELECT**] soft key to step to the next number.

Repeat this procedure until all eight spaces of the MMSI number are entered. If a mistake is made entering in the MMSI number, press the [**◀**] or [**▶**] key to select “**←**” or “**→**”, press the [**SELECT**] soft key until the incorrect character is selected, then perform step 9.

10. When finished entering the MMSI number, press the [**FINISH**] soft key to confirm.
11. To store the data, select “**SAVE**”, then press the [**SELECT**] soft key.
12. To enter another group address, repeat steps 2 through 11.
13. Press the [**CLEAR**] key to return to radio operation.

11.5.2 Transmitting a Group Call

Group Call using the Group Directory

1. [] → “DSC CALL” → “GROUP CALL”
2. Rotate the **DIAL/ENT** knob to select “**HISTORY**” or “**MEMORY**”, then press the [**SELECT**] soft key.
3. Rotate the **DIAL/ENT** knob to select a group you want to contact, then press the [**SELECT**] soft key
4. In the INTERSHIP CH list, rotate the **DIAL/ENT** knob to select the operating channel on which you want to communicate, then press the [**SELECT**] soft key. To select operating channels from all voice channels, press the [**MANUAL**] soft key.
5. Press the [**YES**] soft key to transmit the group call signal.
6. When the group call signal is sent, the display will be as shown in the illustration at the right.
7. After the group call is transmitted, all the radios in the group will switch to the designated channel.
8. Listen to the channel to make sure it is not busy, then press the microphone **PTT** switch to communicate with all of the vessels in the group.

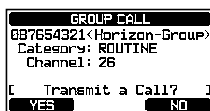
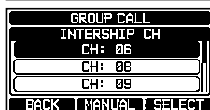
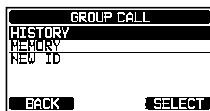

Group Call by Manually Entering an MMSI

This feature allows you to contact a group of vessels by entering in their group MMSI manually.

1. [] → “DSC CALL” → “GROUP CALL”
2. Rotate the **DIAL/ENT** knob to select “**NEW ID**”, then press the [**SELECT**] soft key.

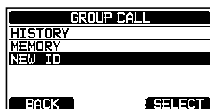

3. Rotate the **DIAL/ENT** knob to select the second number of the MMSI (the first of nine digits is permanently set to "0") which you want to contact, then press the [**SELECT**] soft key to step to the next number.



4. Repeat step 3 to set the MMSI number.
If a mistake is made entering in the MMSI number, press the [**◀**] or [**▶**] key to select "←" or "→", press the [**SELECT**] soft key until the incorrect character is selected, then perform steps 3 and 4.

5. When finished entering the MMSI number, press the [**FINISH**] soft key.

6. In the INTERSHIP CH list, rotate the **DIAL/ENT** knob to select the operating channel on which to communicate, then press the [**SELECT**] soft key. To select operating channels from all voice channels, press the [**MANUAL**] soft key.



7. Press the [**YES**] soft key to transmit the group call signal.

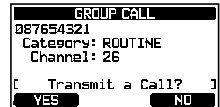

8. After the group call is transmitted, all the radios in the group will switch to the designated channel.

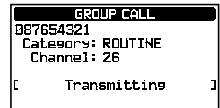

9. Listen to the channel to make sure it is not busy, then press the microphone **PTT** switch to communicate with all of the vessels in the group.



11.5.3 Receiving a Group Call

1. When a group call is received, the transceiver will produce a ringing alarm sound.
2. The display shows the group MMSI number.
3. Press any key to stop the alarm.



On the display 3 soft key selections are shown. These selections are described below:

[ACCEPT]: Press this key to accept the group call and switch to the requested channel.

[PAUSE]: Press this key to temporarily pause automatic switching to the requested channel.

[QUIT]: Press this key to exit the automatic channel switching and revert to the last selected working channel.



- If you want to respond, monitor the channel to make sure it is clear, then press the microphone **PTT** switch and talk into the microphone to communicate with all of the vessels in the group.
- Press the **[QUIT]** soft key to return to radio operation.
NOTE: If a key is not pressed within 30 seconds, the radio will automatically change to radio operation.

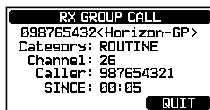

NOTE

When there is an unread group call, the “” icon will appear on the display. You may review the unread group call from the DSC log, refer to section “**11.10.3 Reviewing Other Logged Calls**”.

11.5.4 Setting up the Group Call Ringer

The transceiver group call ringer may be turned OFF using the following procedure:

- Press & hold [] → “DSC SETUP” → “DSC BEEP”
- Rotate the **DIAL/ENT** knob to select “**GROUP CALL**”, then press the **[SELECT]** soft key.
- Rotate the **DIAL/ENT** knob to select “**OFF**”.
- Press the **[ENTER]** soft key to store the selected setting.
- Press the **[CLEAR]** key to return to radio operation.

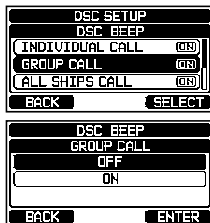

To enable the ringer tone, repeat the above procedure, rotate the **DIAL/ENT** knob to “**ON**” in step 3 above.

11.6 POSITION REQUEST

Advancements in DSC have made it possible to poll the location of another vessel and show the position of that vessel on the display of the **GX2410**. Standard Horizon has taken this feature one step further, if a compatible GPS chart plotter is connected to the **GX2410**, the polled position of the vessel is shown on the display of the GPS chart plotter making it easy to navigate to the location of the polled vessel. This is a great feature for anyone wanting to know the position of another vessel. For example, find where your buddy is catching fish or find the location of a vessel you are cruising with.

NOTE

The other vessel must have an operating GPS receiver connected to its DSC radio, and the radio must not be set to deny position requests. (Refer the section “**11.4 INDIVIDUAL CALL**” to enter information into the individual directory).

11.6.1 Setting up a Position Request Reply

The transceiver can be set up to automatically (default setting) or manually send your position when requested by another vessel. This selection is important if you are concerned about someone polling the position of your vessel that you may not want to. In the manual mode you will see the MMSI (Maritime Mobile Service Identity Number) or persons name shown on the display allowing you to choose whether or not to send your position to the requesting vessel.

1. Press & hold [] ⇒ “DSC SETUP” ⇒ “POSITION REPLY”
2. Rotate the **DIAL/ENT** knob to select “**AUTO**” or “**MANUAL**”. In “**AUTO**” mode, after a DSC POS request is received, the radio will automatically transmit your vessel’s position. In “**MANUAL**” mode, the display of the transceiver will show who is requesting the position and the [YES] soft key on the radio must be pressed to send your position to the requesting vessel.
3. Press the [ENTER] soft key to store the selected setting.
4. Press the [CLEAR] key to return to radio operation.



11.6.2 Transmitting a Position Request to Another Vessel

Position Request using the Individual/Position Directory

Refer to section “**11.4 INDIVIDUAL CALL**” to enter information into the individual directory.

1. [] ⇒ “DSC CALL” ⇒ “POS REQUEST”
2. Rotate the **DIAL/ENT** knob to select “**HISTORY**” or “**MEMORY**”, then press the [SELECT] soft key.
3. Rotate the **DIAL/ENT** knob to select a name that is stored in the individual/position directory.



4. Press the [**SELECT**] soft key, then press the [**YES**] soft key to transmit the position request DSC call.
5. When the transceiver receives the position from the polled vessel it is shown on the radio display.
6. Press the [**QUIT**] soft key to return to radio operation.



NOTE

If the transceiver does not receive position data from the polled vessel, the display will show as follows.

```
--.--.---- _
--.--.---- _
```

Position Request by Manually Entering an MMSI

This feature allows you to request the position of a vessel by manually entering the MMSI.

1. [**MENU / SET**] → “DSC CALL” → “POS REQUEST”

2. Rotate the **DIAL/ENT** knob to select “NEW ID”, then press the [**SELECT**] soft key.

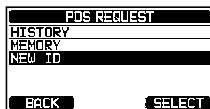

3. Press the [◀] or [▶] key to select the first number of the MMSI (nine digits) which you want to contact, then press the [**SELECT**] soft key to step to the next number.



4. Repeat step 3 to set the MMSI number.
If a mistake is made entering in the MMSI number, press the [◀] or [▶] key to select “←” or “→”, press the [**SELECT**] soft key until the incorrect character is selected, then perform step 3.
5. When finished entering the MMSI number, press the [**FINISH**] soft key.
6. Press the [**YES**] soft key to transmit the position request DSC call.



- When the transceiver receives the position from the polled vessel it is shown on the radio display.
- Press the **[QUIT]** soft key to return to radio operation.



NOTE

The received position from the polled vessel can be transferred to a GPS chart plotter via NMEA DSC and DSE sentences.

11.6.3 Receiving a Position Request

- When a position request call is received from another vessel, a ringing sound will be produced, and the display will be as shown in the illustration at the right.
- Press any key to stop the alarm.
- To send your vessel's position to the requesting vessel, press the **[REPLY]** soft key.
Or to exit from position request display, press the **[QUIT]** soft key.
- Press the **[QUIT]** soft key to return to the channel display.



NOTE

When there is an unread position request call, the "☒" icon will appear on the display. You may review the unread individual call from the DSC log, refer to section "11.10.3 Reviewing Other Logged Calls".

11.6.4 Manual Input of Position Information

If the transceiver is located in an area where GPS reception is limited when you are going to reply to the received position request, you may manually input your location (latitude and longitude) and time to be sent.

- [MENU SET]** → "MMSI/POS INFO"

- Press the **[POS/TM]** soft key.

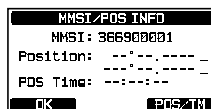

- Press the [◀] or [▶] key to select the first number of latitude, then press the [SELECT] soft key to step to the next number.

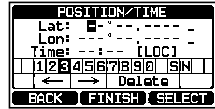

- Repeat step 3 to set the position and time.
If a mistake is made, press the [◀] or [▶] key to select “←” or “→”, press the [SELECT] soft key until the incorrect character is selected, then perform step 3.
- When finished programming the position and time, press the [FINISH] soft key. The display will return to the previous screen.
- Press the [OK] soft key.
- Press the [CLEAR] key to return to radio operation.

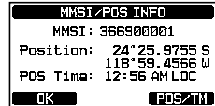

11.6.5 Setting up a Position Request Ringer

The transceiver has the capability to turn off the position request ringer.

- Press & hold [MENU/SET] → “DSC SETUP” → “DSC BEEP”

- Rotate the **DIAL/ENT** knob to select “POS REQUEST”, then press the [SELECT] soft key.



- Rotate the **DIAL/ENT** knob to select “OFF”.
- Press the [ENTER] soft key to store the selected setting.
- Press the [CLEAR] key to return to radio operation.

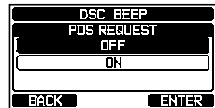

To enable the ringer tone, repeat the above procedure, rotate the **DIAL/ENT** knob to select “ON” in step 3 above.

11.7 POSITION REPORT

The feature is similar to position request, however instead of requesting a position of another vessel this function allows you to send your position to another vessel.

11.7.1 Transmitting a DSC Position Report Call

DSC Position Report Call using the Individual/Position Directory

Refer to section “11.4 INDIVIDUAL CALL” to enter information into the individual directory.

- [MENU/SET] → “DSC CALL” → “POS REPORT”

2. Rotate the **DIAL/ENT** knob to select “**HISTORY**” or “**MEMORY**”, then press the [**SELECT**] soft key.
3. Rotate the **DIAL/ENT** knob to select the name in the directory, then press the [**SELECT**] soft key.
4. If you want to change the position displayed, press the [**POS/TM**] soft key to go to the position information input screen. After inputting new position information, press the [**FINISH**] soft key to confirm.
5. Press the [**YES**] soft key to send your position to the selected vessel.
6. Press the [**QUIT**] soft key to return to radio operation.

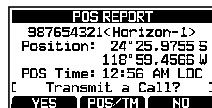
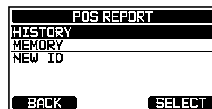

DSC Position Report Call by Manually Entering an MMSI

This feature allows you to send your position to another vessel by manually entering the MMSI of the ship you want to send your position to.

1. [**MENU/SET**] ⇒ “**DSC CALL**” ⇒ “**POS REPORT**”

2. Rotate the **DIAL/ENT** knob to select “**NEW ID**”, then press the [**SELECT**] soft key.

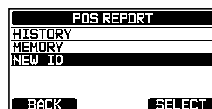

3. Rotate the **DIAL/ENT** knob to select the first number of the MMSI of the vessel you want to contact, then press the [**SELECT**] soft key to step to the next number.
4. Repeat step 3 to complete the MMSI number.

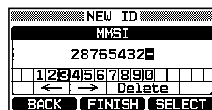

- If a mistake is made entering in the MMSI number, press the [◀] or [▶] key to select “←” or “→”, press the [**SELECT**] soft key until the incorrect character is selected, then perform step 3.
5. When finished entering the MMSI number, press the [**FINISH**] soft key.
6. If you want to change the position displayed, press the [**POS/TM**] soft key to go to the position information input screen. After inputting the new position information, press the [**FINISH**] soft key to confirm.

7. Press the **[YES]** soft key to send your position to the selected vessel.

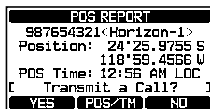

8. Press the **[QUIT]** soft key to return to radio operation.

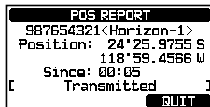

11.7.2 Receiving a DSC Position Report Call

When another operator transmits their vessels location to another **GX2410** receiver the following will happen:

1. When a position report call is received from another vessel, a ringing sound will be produced.
2. Press any key to stop ringing.
3. To exit to radio mode, press the **[QUIT]** soft key.

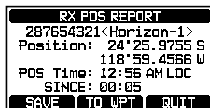
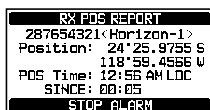

11.7.3 Navigating to the Reported Position

The transceiver has a feature that permits navigate to a received position report call by using the compass display. Navigation to the location of a position report call may be enabled by the procedure below.

1. Press the **[TO WPT]** soft key.
2. Press the **[ENTER]** soft key to save the waypoint into memory.
3. The display indicates the distance and direction of the received vessel, and the compass displays the received vessel with a dot (●).

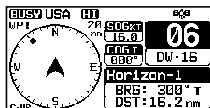
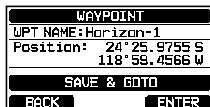
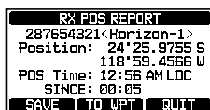

Stopping Navigation to the Reported Position

1. Press one of the soft keys, then press the **[STOP]** soft key.

The radio will stop navigating to the waypoint and the normal VHF display will be shown.

