

TEST REPORT

For EMC

Report Reference No.....: CHTW24070083

Report verification : 

Project No.: SHT2407005802W

FCC ID.....: K6630673Y3D

Applicant's name.....: YAESU MUSEN CO., LTD.

Address: Omori Bellport D building 3F, 6-26-3 Minamioi, Shinagawa-ku,
Tokyo 140-0013 Japan

Test item description: VHF FM Marine Transceiver

Trade Mark: Standard Horizon

Model/Type reference: GX2410GPS

Listed Model(s): -

Standard: IEC60945:2002

Date of receipt of test sample.....: Jul.09, 2024

Date of testing.....: Jul.10, 2024 - Jul.22, 2024

Date of issue.....: Jul.23, 2024

Result.....: PASS

Compiled by
 (position+printed name+signature) .: File administrators Caspar Chen



Supervised by
 (position+printed name+signature) .: Project Engineer Caspar Chen



Approved by
 (position+printedname+signature): RF Manager Xu Yang

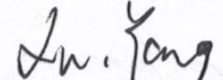

Testing Laboratory Name: Shenzhen Huatongwei International Inspection Co., Ltd.

Address: Building 7, Baiwang Idea Factory, No.1051, Songbai Road,
Yangguang Community, Xili Subdistrict, Nanshan District,
Shenzhen, Guangdong, China

Shenzhen Huatongwei International Inspection Co., Ltd. All rights reserved.

This publication may be reproduced in whole or in part for non-commercial purposes as long as the Shenzhen Huatongwei International Inspection Co., Ltd. is acknowledged as copyright owner and source of the material. Shenzhen Huatongwei International Inspection Co., Ltd. takes no responsibility for and will not assume liability for damages resulting from the reader's interpretation of the reproduced material due to its placement and context.

The test report merely corresponds to the test sample.

Contents

1.	<u>TEST STANDARDS AND REPORT VERSION</u>	<u>3</u>
1.1.	Test Standards	3
1.2.	Report version	3
2.	<u>TEST DESCRIPTION</u>	<u>4</u>
3.	<u>SUMMARY</u>	<u>5</u>
3.1.	Client Information	5
3.2.	Product Description	5
3.3.	EUT operation mode	6
3.4.	Support unit used in test configuration and system	6
4.	<u>TEST ENVIRONMENT.....</u>	<u>7</u>
4.1.	Address of the test laboratory	7
4.2.	Environmental conditions	7
4.3.	Statement of the measurement uncertainty	7
4.4.	Equipments Used during the Test	8
5.	<u>TEST CONDITIONS AND RESULTS</u>	<u>11</u>
5.1.	EMISSION	11
5.1.1.	Conducted Emissions	11
5.1.2.	Radiated Emission	13
5.2.	IMMUNITY	17
5.2.1.	Conducted radio frequency disturbance	18
5.2.2.	Radiated radio frequencies	19
5.2.3.	Fast transients (bursts)	20
5.2.4.	Slow transients (surges)	21
5.2.5.	Power supply transients	22
5.2.6.	Power supply variations and failure	23
5.2.7.	Electrostatic Discharge	24
5.3.	Environmental Test	27
5.3.1.	Dry heat	27
5.3.2.	Damp heat	27
5.3.3.	Low temperature	28
5.3.4.	Vibration	28
6.	<u>TEST SETUP PHOTOS.....</u>	<u>29</u>
7.	<u>EXTERNAL AND INTERNAL PHOTOS OF THE EUT.....</u>	<u>31</u>

1. Test standards and Report version

1.1. Test Standards

The tests were performed according to following standards:

[IEC60945:2002](#)—Maritime navigation and radiocommunication equipment and systems -General requirements
-Methods of testing and required test result

1.2. Report version

Version No.	Date of issue	Description
N/A	2024-07-23	Original

2. Test Description

Emission			
Test item	Standards requirement (IEC60945)	Result	Test Engineer
Conducted emissions	Sub-clause 9.2	Pass	Junman Wang
Radiated emissions	Sub-clause 9.3	Pass	Yifan Wang
Immunity			
Test item	Standards requirement (IEC60945)	Result	Test Engineer
Conducted radio frequency disturbance	Sub-clause 10.3	Pass	Chuanfeng Li
Radiated disturbance	Sub-clause 10.4	Pass	Jianjun Liang
Fast transients (bursts)	Sub-clause 10.5	Pass	Jian Li
Slow transients (surges)	Sub-clause 10.6	N/A	-
Power supply transients	Sub-clause 10.7	N/A	-
Power supply variations and failure	Sub-clause 10.8	N/A	-
Electrostatic discharge	Sub-clause 10.9	Pass	Jian Li
Environmental Test			
Test item	Standards requirement (IEC60945)	Result	Test Engineer
Dry heat	Sub-clause 8.2	Pass	Yifan Wang
Damp heat	Sub-clause 8.3	Pass	Yifan Wang
Low temperature	Sub-clause 8.4	Pass	Yifan Wang
Vibration	Sub-clause 8.7	Pass	Yifan Wang

Note: The measurement uncertainty is not included in the test result.

3. Summary

3.1. Client Information

Applicant:	YAESU MUSEN CO., LTD.
Address:	Omori Bellport D building 3F, 6-26-3 Minamioi, Shinagawa-ku, Tokyo 140-0013 Japan
Manufacturer:	YAESU MUSEN CO.,LTD.
Address:	43 Utsuroda, Morijuku, Sukagawa-shi,Fukushima 962-0001 Japan

3.2. Product Description

Main unit	
Name of EUT:	VHF FM Marine Transceiver
Trade mark:	Standard Horizon
Mode No.:	GX2410GPS
Listed Model(s):	-
Power supply:	DC 13.8V
Hardware Version:	N/A
Software Version:	N/A
RF Specification	
Operation Frequency Range:	TX:156.025MHz to 157.425MHz RX:156.050MHz to 162.000MHz
Rated Output Power:	<input checked="" type="checkbox"/> High Power: 25W <input checked="" type="checkbox"/> Low Power: 1W
Modulation Type:	Analog: FM
	Digital Data(DSC): AFSK
Channel Separation:	Analog: <input checked="" type="checkbox"/> 25kHz
	Digital Data(DSC): <input checked="" type="checkbox"/> 25kHz
Emission Designator: *1	Analog: 16K0G3E
	Digital Data(DSC): 16K0G2B

Note:

(1) *1 According to FCC Part 2.202 requirements, the Necessary Bandwidth is calculated as follows:

- For FM Voice Modulation

Channel Spacing = 25 KHz, D = 5KHz max, K = 1, M = 3KHz

$B_n = 2M + 2DK = 2 \times 3 + 2 \times 5 \times 1 = 16 \text{ KHz}$

Emission designation: 16K0G3E

- Digital Data(DSC)

Channel Spacing = 25 KHz, D = 5KHz max, K = 1, M = 3KHz

$B_n = 2M + 2DK = 2 \times 3 + 2 \times 5 \times 1 = 16 \text{ KHz}$

Emission designation: 16K0G2B

3.3. EUT operation mode

Test mode	Transmitting	Receiving	Power level	
			High	Low
TX-AWH	√		√	
TX-AWL	√			√
TX-DSC	√		√	
RX-AW		√		
RX-DSC		√		

√ : is operation mode.

3.4. Support unit used in test configuration and system

The EUT has been associated with peripherals and configuration operated in a manner tended to maximize its emission characteristics in a typical application.

The following peripheral devices and interface cables were connected during the measurement:

Whether support unit is used?			
√ No			
Item	Equipment	Trade Name	Model No.
1			
2			

4. Test Environment

4.1. Address of the test laboratory

Laboratory Name	Shenzhen Huatongwei International Inspection Co., Ltd.	
Laboratory Location	Building 7, Baiwang Idea Factory, No.1051, Songbai Road, Yangguang Community, Xili Subdistrict, Nanshan District, Shenzhen, Guangdong, China	
Connect information:	Tel: 86-755-26715499 E-mail: cs@szhtw.com.cn http://www.szhtw.com.cn	
Qualifications	Type	Accreditation Number
	FCC Registration Number	762235
	FCC Designation Number	CN1181

4.2. Environmental conditions

During the measurement the environmental conditions were within the listed ranges:

Normal Temperature:	25°C
Relative Humidity	55 %
Air Pressure	989 hPa

4.3. Statement of the measurement uncertainty

No.	Test Items	Measurement Uncertainty
1	Radiated Emission	4.54dB for 30MHz-1GHz 5.10dB for above 1GHz
2	Conducted emissions	3.21dB
3	Radio frequency electromagnetic field 80-6000MHz	12.3%
4	Electrostatic Discharge	-
5	Temperature	1°C
6	Humidity	5%

This uncertainty represents an expanded uncertainty expressed at approximately the 95% confidence level using a coverage factor of k=1.96.

4.4. Equipments Used during the Test

● Conducted Emission							
Used	Test Equipment	Manufacturer	Equipment No.	Model No.	Serial No.	Last Cal. Date (YY-MM-DD)	Next Cal. Date (YY-MM-DD)
●	EMI Test Receiver	R&S	HTWE0111	ESCI	101247	2023/08/30	2024/08/29
●	Artificial Mains	SCHWARZBECK	HTWE0113	NNLK 8121	573	2023/08/18	2024/08/17
●	Protection Network	SCHWARZBECK	HTWE0567	VTSD9561FN	00899	2023/08/18	2024/08/17
●	ISN	FCC	HTWE0148	FCC-TLISN-T2-02	20371	2023/08/18	2024/08/17
●	ISN	FCC	HTWE0150	FCC-TLISN-T8-02	20375	2023/08/18	2024/08/17
●	Test Software	R&S	N/A	EMC32	N/A	N/A	N/A

● Radiated Emission-9kHz~30MHz							
Used	Test Equipment	Manufacturer	Equipment No.	Model No.	Serial No.	Last Cal. Date (YY-MM-DD)	Next Cal. Date (YY-MM-DD)
●	Semi-Anechoic Chamber	Albatross projects	HTWE0127	SAC-3m-02	C11121	2023/04/06	2026/04/05
●	EMI Test Receiver	R&S	HTWE0099	ESCI 7	100900	2023/8/30	2024/8/29
●	Loop Antenna	R&S	HTWE0170	HFH2-Z2	100020	2024/04/08	2027/04/07
●	Test Software	R&S	N/A	EMC32	N/A	N/A	N/A

● Radiated Emission-30MHz~1GHz 3M							
Used	Test Equipment	Manufacturer	Equipment No.	Model No.	Serial No.	Last Cal. Date (YY-MM-DD)	Next Cal. Date (YY-MM-DD)
●	Semi-Anechoic Chamber	Albatross projects	HTWE0127	SAC-3m-02	C11121	2023/04/06	2026/04/05
●	EMI Test Receiver	R&S	HTWE0099	ESCI 7	100900	2023/08/30	2024/08/29
●	Ultra-Broadband Antenna	SCHWARZBECK	HTWE0119	VULB9163	546	2023/02/22	2026/02/21
●	Pre-Amplifier	SCHWARZBECK	HTWE0295	BBV 9742	/	2024/5/24	2025/5/23
●	Test Software	R&S	N/A	EMC32	N/A	N/A	N/A

● Radiated emission-Above 1GHz							
Used	Test Equipment	Manufacturer	Equipment No.	Model No.	Serial No.	Last Cal. Date (YY-MM-DD)	Next Cal. Date (YY-MM-DD)
●	Semi-Anechoic Chamber	Albatross projects	HTWE0122	SAC-3m-01	C11121	2023/04/17	2026/04/16
●	Spectrum Analyzer	R&S	HTWE0098	FSP40	100597	2023/08/22	2024/08/21
●	Horn Antenna	SCHWARZBECK	HTWE0126	BBHA 9120D	1011	2023/02/14	2026/02/13
●	Horn Antenna	SCHWARZBECK	HTWE0103	BBHA9170	BBHA9170472	2023/02/20	2026/02/19
●	Broadband Pre-amplifier	SCHWARZBECK	HTWE0551	SCU18F	100855	2024/6/6	2025/6/5
●	Test Software	R&S	N/A	EMC32	N/A	N/A	N/A

● Electrostatic Discharge

Used	Test Equipment	Manufacturer	Equipment No.	Model No.	Serial No.	Last Cal. Date (YY-MM-DD)	Next Cal. Date (YY-MM-DD)
●	ESD Simulator	EM TEST	HTWE0500	esd NX30.1	11971	2024/4/20	2025/4/19

● Radio Frequency Electromagnetic Field

Used	Test Equipment	Manufacturer	Equipment No.	Model No.	Serial No.	Last Cal. Date (YY-MM-DD)	Next Cal. Date (YY-MM-DD)
●	Anechoic Chamber	CRT	HTWE0418	8.0*5.0*4.0 m	CRTSAC845	2023/03/18	2028/03/17
●	Signal Generator	R&S	HTWE0276	SMB100A	114360	2024/3/14	2025/3/13
●	Amplifier	R&S	HTWE0277	BBA150-BC500	102664	2024/3/14	2025/3/13
●	Amplifier	R&S	HTWE0395	BBA150 D400	104197	2024/3/14	2025/3/13
●	Amplifier	R&S	HTWE0396	BBA150 E400	104198	2024/3/14	2025/3/13
●	Power Head	R&S	HTWE0278	NRP18A	101010	2024/3/14	2025/3/13
●	Power Head	R&S	HTWE0389	NRP18A	101386	2024/3/14	2025/3/13
●	Transmit Antenna	Schwarzbeck	HTWE0280	STLP9129	00044	2023/9/20	2024/9/19
●	Field Probe	ETS-LINDGREN	HTWE0321	HI-6153	00130812	2023/11/17	2024/11/16
●	Test Software	R&S	N/A	EMC32	N/A	N/A	N/A

● Electrical fast transient/burst immunity test

Used	Test Equipment	Manufacturer	Equipment No.	Model No.	Serial No.	Last Cal. Date (YY-MM-DD)	Next Cal. Date (YY-MM-DD)
●	Transient immunity simulator	EM TEST	HTWE0512	compact NX5	P2125254008	2024/3/14	2025/3/13
●	3-Phase Coupling Network	EM TEST	HTWE0516	coupling NX5	P2128254484	2024/3/14	2025/3/13
○	Coupling Clamp	EM TEST	HTWE0513	CCI	P2125253835	2024/3/14	2025/3/13
●	Test Software	EM TEST	N/A	ISM IEC	N/A	N/A	N/A

● Radio frequency (common mode)							
Used	Test Equipment	Manufacturer	Equipment No.	Model No.	Serial No.	Last Cal. Date (YY-MM-DD)	Next Cal. Date (YY-MM-DD)
●	Signal Generator	R&S	HTWE0603	SMC100A	108535	2024/3/14	2025/3/13
●	Amplifier	R&S	HTWE0606	BBA150-A125	104839	2024/3/14	2025/3/13
●	6db Attenuator	Bird	HTWE0622	150-A-FFN6	2129	2024/6/6	2025/6/5
●	Power Head	R&S	HTWE0604	NRP6AN	101713	2024/3/14	2025/3/13
●	Power Head	R&S	HTWE0605	NRP6AN	101714	2024/3/14	2025/3/13
●	CDN	EMTEST	HTWE0609	CDN M2/M3PE 16A	00083	2023/8/18	2024/8/17
●	Test Software	R&S	N/A	EMC32	N/A	N/A	N/A

● Auxiliary Equipment							
Used	Test Equipment	Manufacturer	Equipment No.	Model No.	Serial No.	Last Cal. Date (YY-MM-DD)	Next Cal. Date (YY-MM-DD)
○	Radio communication tester	R&S	HTWE0287	CMW500	137688-Lv	2023/08/25	2024/08/24
●	RF Communication Test Set	HP	HTWE0038	8920A	3813A10206	2023/08/22	2024/08/21
●	Digital intercom communication tester	Aeroflex	HTWE0255	3920B	1001682041	2023/08/22	2024/08/21
○	Audio analyzer	R&S	HTWE3008	UPV	101371	2023/09/29	2024/09/28

5. Test conditions and Results

5.1. EMISSION

5.1.1. Conducted Emissions

LIMIT

Please refer to IEC60945 Clause 9.1, Table 5

Conducted emissions (9.2)	10 kHz – 150 kHz	63 mV – 0,3 mV (96 dB μ V – 50 dB μ V)
	150 kHz – 350 kHz	1 mV – 0,3 mV (60 dB μ V – 50 dB μ V)
	350 kHz – 30 MHz	0,3 mV (50 dB μ V)

TEST CONFIGURATION

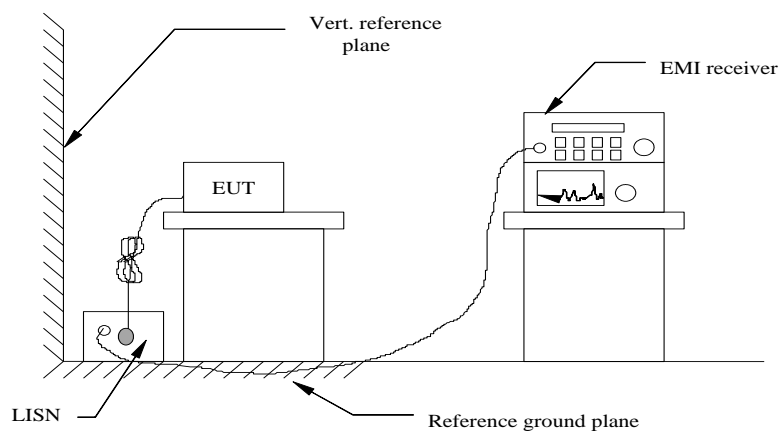

TEST PROCEDURE

Please refer to IEC60945 Clause 9.2.2 for the measurement methods

TEST MODE:

Please reference to the section 3.3

TEST RESULTS

Passed Not Applicable

RX-AW mode

Polarization

+

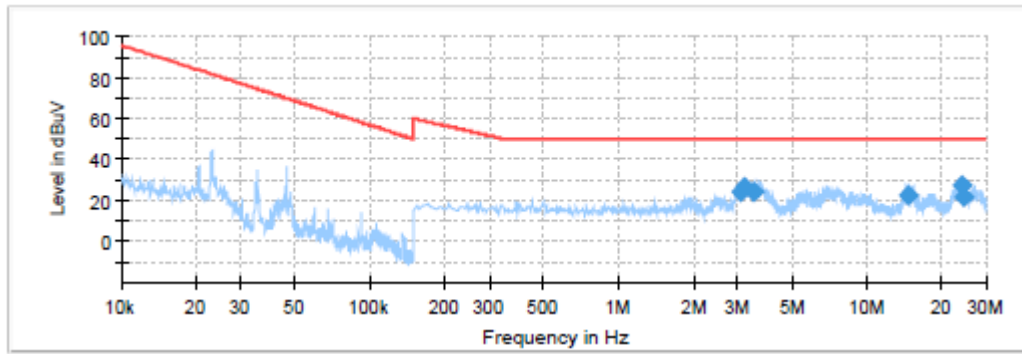

Final Result

Frequency (MHz)	QuasiPeak (dBuV)	CAverage (dBuV)	Limit (dBuV)	Margin (dB)	Line	Corr. (dB)
3.1155	23.92	---	50.00	26.08	L1	11.0
3.2035	26.83	---	50.00	23.17	L1	11.0
3.4995	24.08	---	50.00	25.92	L1	11.0
14.4795	22.47	---	50.00	27.53	L1	11.3
23.8795	27.56	---	50.00	22.44	L1	11.4
24.2755	21.28	---	50.00	28.72	L1	11.4

RX-AW mode

Polarization

-

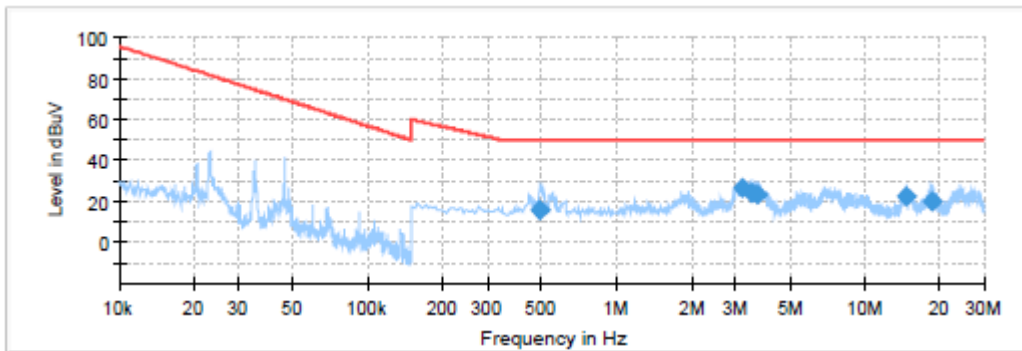

Final Result

Frequency (MHz)	QuasiPeak (dBuV)	CAverage (dBuV)	Limit (dBuV)	Margin (dB)	Line	Corr. (dB)
0.4915	15.96	---	50.00	34.04	N	10.7
3.2035	26.66	---	50.00	23.34	N	10.8
3.4755	24.54	---	50.00	25.46	N	10.8
3.6875	23.63	---	50.00	26.37	N	10.8
14.5475	22.43	---	50.00	27.57	N	11.0
18.5555	20.04	---	50.00	29.96	N	11.0

5.1.2. Radiated Emission

LIMIT

Please refer to IEC60945 Clause 9.1, Table 5

Radiated emissions (9.3)	150 kHz – 300 kHz	10 mV/m – 316 μ V/m (80 dB μ V/m – 52 dB μ V/m)
	300 kHz – 30 MHz	316 μ V/m – 50 μ V/m (52 dB μ V/m – 34 dB μ V/m)
	30 MHz – 2 GHz	500 μ V/m (54 dB μ V/m) except for
	156 MHz – 165 MHz	16 μ V/m (24 dB μ V/m) quasi-peak or 32 μ V/m (30 dB μ V/m) peak

TEST CONFIGURATION

➤ below 30MHz:

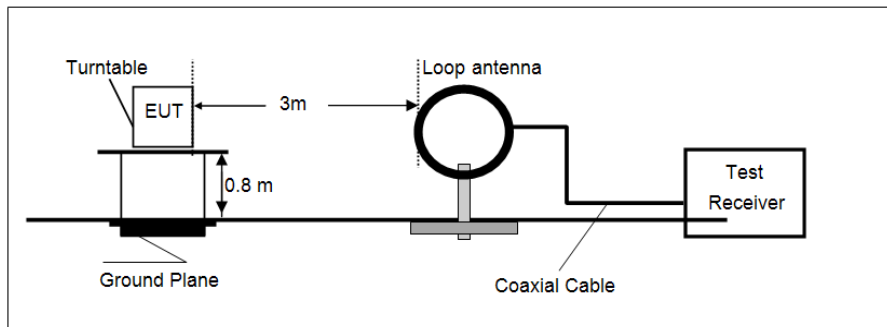

➤ Above 30MHz

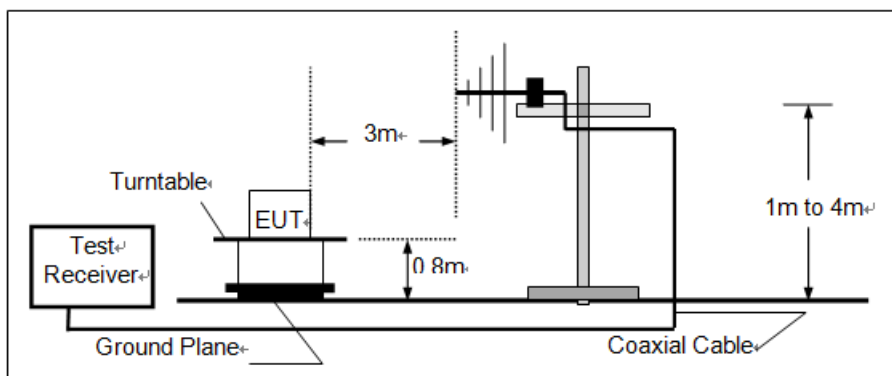

TEST PROCEDURE

Please refer to IEC60945 Clause 9.3.2 for the measurement methods

TEST MODE:

Please refer to the Clause 3.3

TEST RESULTS

Passed Not Applicable

RX-AW mode

Polarization

150K-30MHz

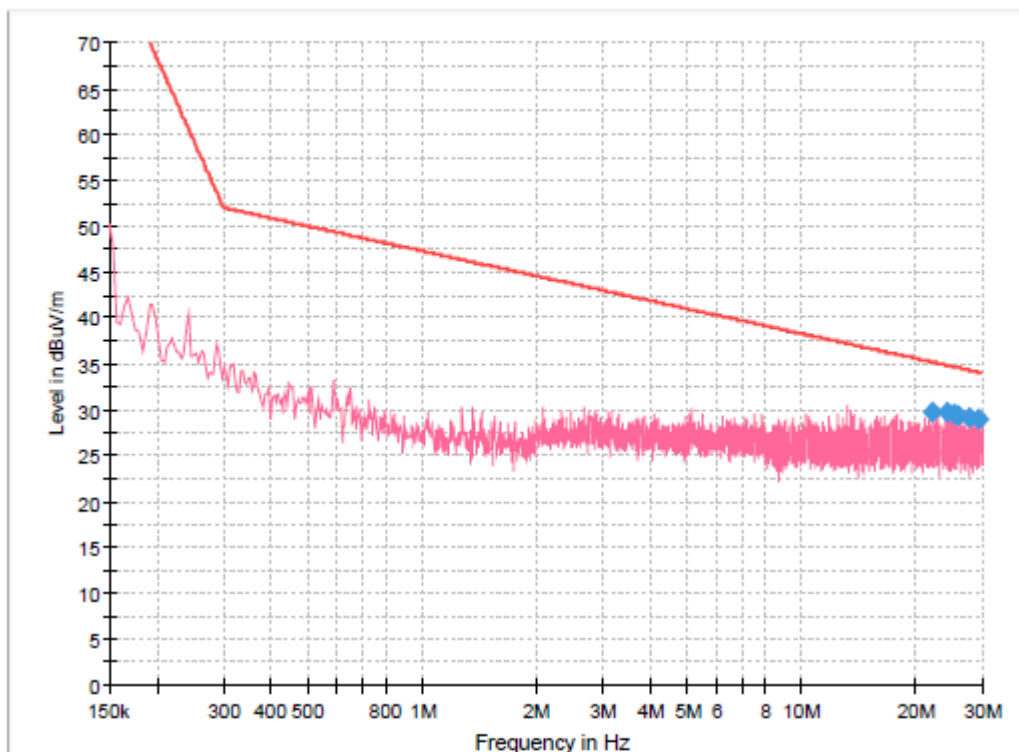

Final Result

Frequency (MHz)	MaxPeak (dBuV/m)	Limit (dBuV/m)	Margin (dB)	Pol	Azimuth (deg)	Corr. (dB/m)	Comment
22.2017	29.63	35.18	5.54	V	164.0	20.9	9:43:28 am - 17/07/2024
24.2315	29.69	34.84	5.14	V	58.0	20.9	9:43:28 am - 17/07/2024
25.3471	29.45	34.66	5.21	V	217.0	20.9	9:43:28 am - 17/07/2024

Frequency (MHz)	MaxPeak (dBuV/m)	Limit (dBuV/m)	Margin (dB)	Pol	Azimuth (deg)	Corr. (dB/m)	Comment
25.8732	29.37	34.58	5.21	V	228.0	20.9	9:43:28 am - 17/07/2024
27.7277	29.06	34.31	5.25	V	17.0	20.9	9:43:28 am - 17/07/2024
29.3060	28.85	34.09	5.24	V	164.0	20.9	9:43:28 am - 17/07/2024

RX-AW mode

Polarization

Vertical

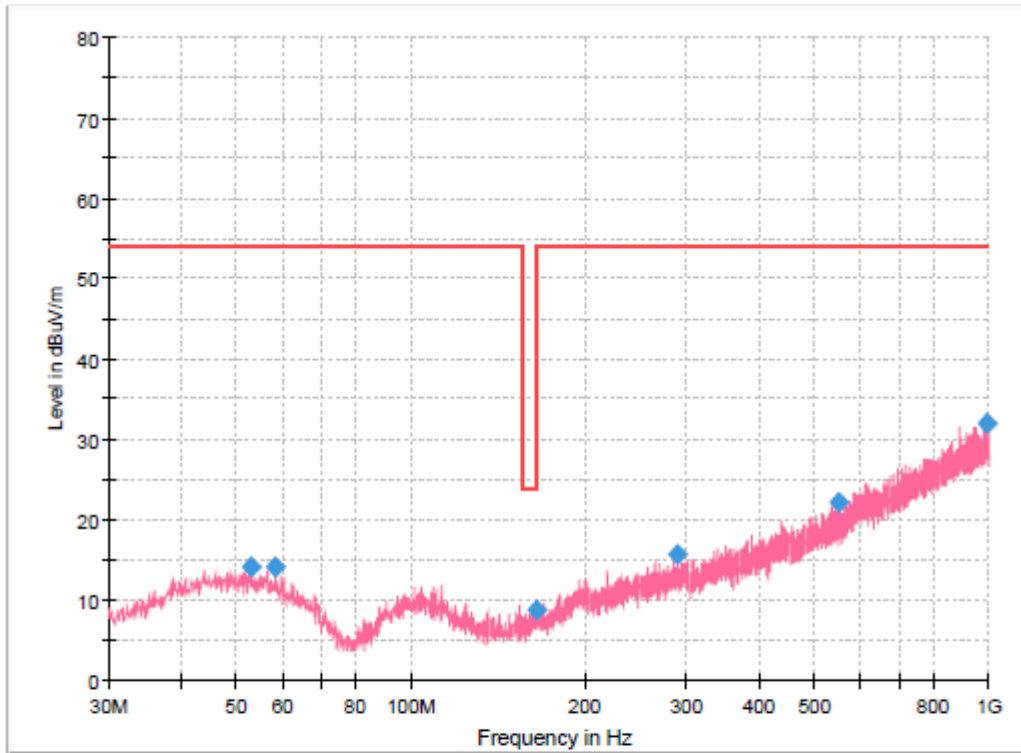

Final Result

Frequency (MHz)	MaxPeak (dBuV/m)	Limit (dBuV/m)	Margin (dB)	Height (cm)	Pol	Azimuth (deg)	Corr. (dB/m)
53.1588	14.00	54.00	40.00	100.0	V	0.0	-8.6
58.2513	14.13	54.00	39.87	100.0	V	244.0	-9.2
164.9513	8.72	24.00	15.28	100.0	V	219.0	-12.9
288.5050	15.67	54.00	38.33	100.0	V	232.0	-7.2
548.5863	22.14	54.00	31.86	100.0	V	0.0	-0.4
994.3013	32.00	54.00	22.00	100.0	V	211.0	8.3

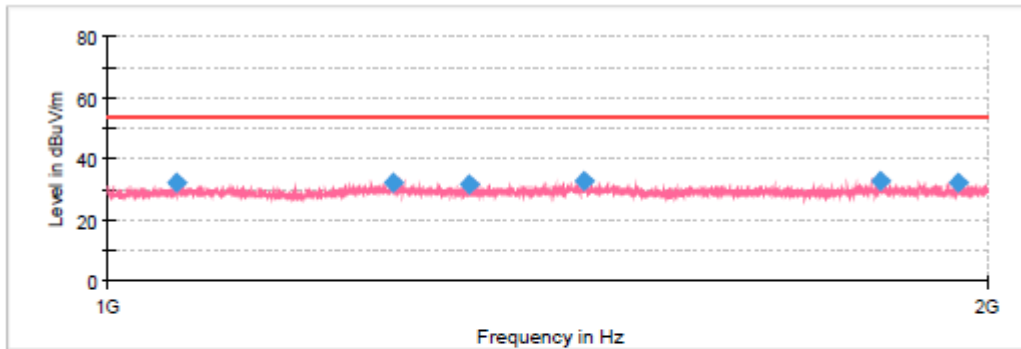

Final Result

Frequency (MHz)	MaxPeak (dBuV/m)	Average (dBuV/m)	Limit (dBuV/m)	Margin (dB)	Height (cm)	Pol	Azimuth (deg)	Corr. (dB/m)
1055.7500	31.95	---	54.00	22.05	150.0	V	351.0	-14.7
1252.0000	32.01	---	54.00	21.99	150.0	V	319.0	-13.5
1328.3750	31.83	---	54.00	22.17	150.0	V	137.0	-13.0
1455.0000	32.88	---	54.00	21.12	150.0	V	319.0	-13.1
1837.1250	32.77	---	54.00	21.23	150.0	V	148.0	-13.0
1952.8750	32.38	---	54.00	21.62	150.0	V	133.0	-12.5

RX-AW mode

Polarization

Horizontal

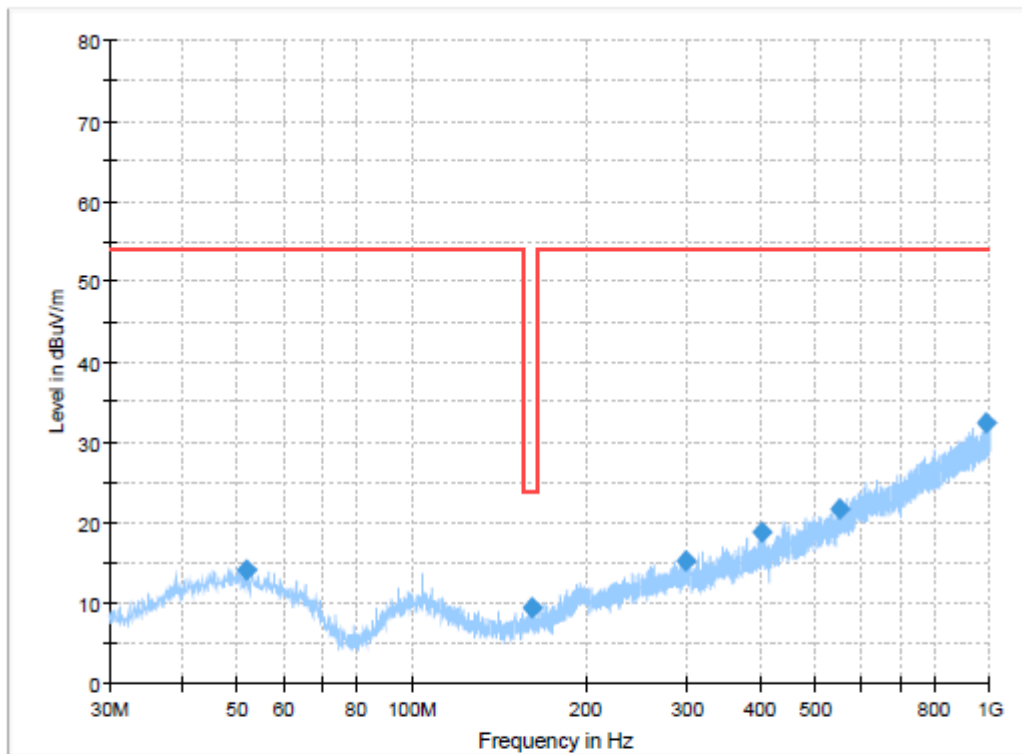

Final Result

Frequency (MHz)	MaxPeak (dBuV/m)	Limit (dBuV/m)	Margin (dB)	Height (cm)	Pol	Azimuth (deg)	Corr. (dB/m)
51.7038	14.11	54.00	39.89	100.0	H	175.0	-8.4
162.0413	9.29	24.00	14.71	100.0	H	119.0	-13.1
297.8413	15.27	54.00	38.73	300.0	H	342.0	-7.0
402.8438	18.85	54.00	35.15	300.0	H	227.0	-3.8
548.5863	21.79	54.00	32.21	300.0	H	342.0	-0.4
985.3288	32.35	54.00	21.65	300.0	H	227.0	8.0

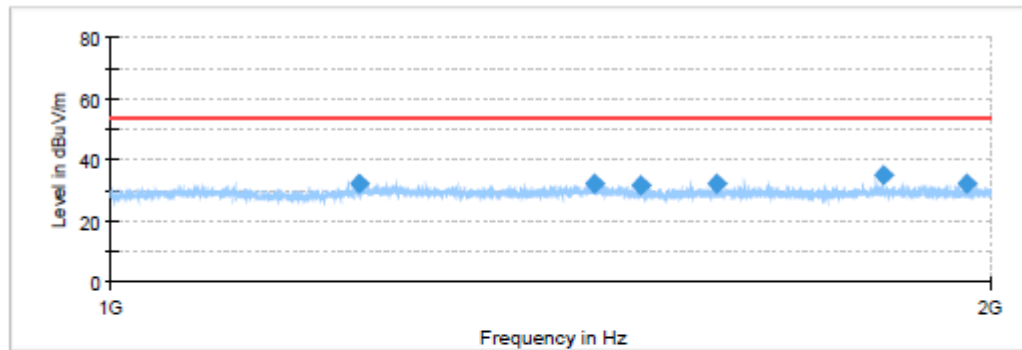

Final Result

Frequency (MHz)	MaxPeak (dBuV/m)	Average (dBuV/m)	Limit (dBuV/m)	Margin (dB)	Height (cm)	Pol	Azimuth (deg)	Corr. (dB/m)
1216.7500	32.11	---	54.00	21.89	150.0	H	0.0	-13.7
1463.2500	32.35	---	54.00	21.65	150.0	H	209.0	-13.2
1517.2500	31.78	---	54.00	22.22	150.0	H	117.0	-13.4
1611.6250	31.95	---	54.00	22.05	150.0	H	209.0	-13.7
1837.1250	34.92	---	54.00	19.08	150.0	H	129.0	-13.0
1963.6250	32.36	---	54.00	21.64	150.0	H	38.0	-12.4

5.2. IMMUNITY

Performance criteria

No change of the actual operational states of the test objects is allowed. However, temporary change is allowed during the power supply failure test.

In addition, the following generic acceptance criteria for compliance were in force during the EMC immunity testing:

- Performance Criterion A: (For continuous phenomena): The EUT shall continue to operate as intended during and after the test. No degradation of performance or loss of function is allowed as defined in the relevant equipment standard and in the technical specification published by the manufacturer.
- Performance Criterion B: (For transient phenomena): The EUT shall continue to operate as intended after the tests. No degradation of performance or loss of function is allowed as defined in the technical specification published by the manufacturer. During the test, degradation or loss of function or performance which is self-recoverable is, however, allowed but no change of actual operating state or stored data is allowed.
- Performance Criterion C: Temporary degradation or loss of function or performance is allowed during and after the test, provided the function is self-recoverable, or can be restored by the operation of the controls as defined in the relevant equipment standard and in the technical specification published by the manufacturer.

5.2.1. Conducted radio frequency disturbance

PERFORMANCE CRITERION

Performance criterion: A.

TEST CONFIGURATION

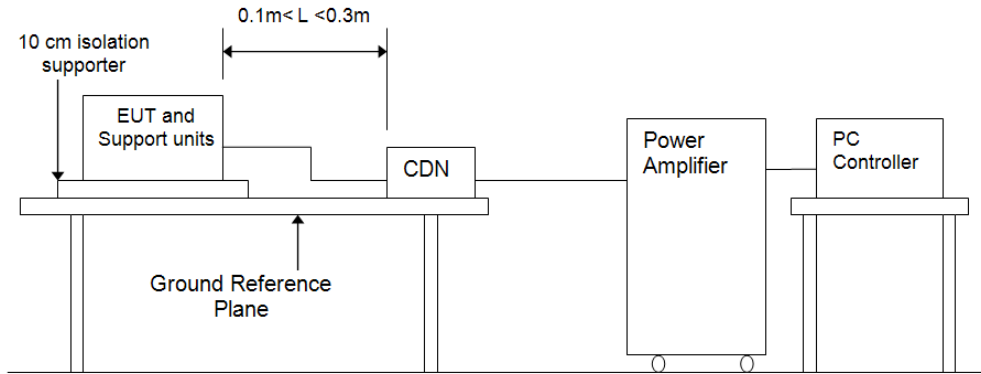

TEST PROCEDURE

Please refer to IEC60945 Clause 10.3.2 for the measurement methods

TEST MODE

Please reference to the section 3.3

TEST RESULTS

Passed Not Applicable

Test mode:	All modes		
Injected Position	Observations (Performance Criterion)	Criteria Level	Result
DC power ports	<i>No degradation in performance of the EUT was observed. (A)</i>	A	Pass

5.2.2. Radiated radio frequencies

PERFORMANCE CRITERION

Criteria A

TEST CONFIGURATION

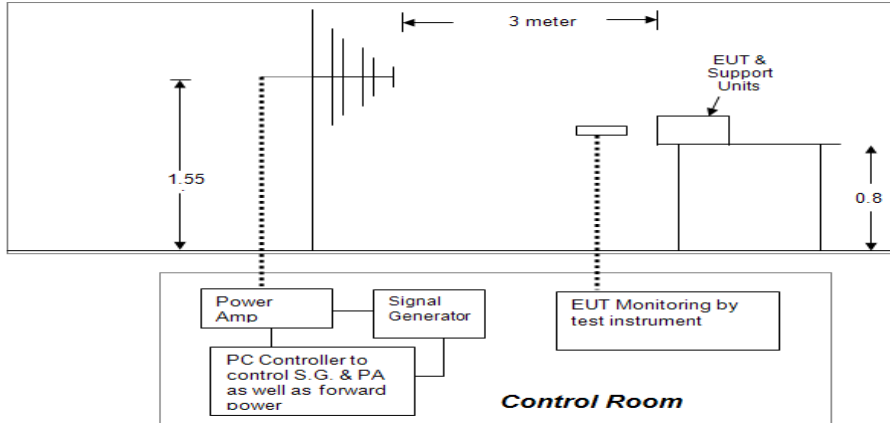

TEST PROCEDURE

Please refer to IEC60945 Clause 10.4.2 for the measurement methods

TEST MODE

Please reference to the section 3.3

TEST RESULTS

Passed **Not Applicable**

Please refer to the below test data:

Test mode	All modes					
Frequency	Level	Modulation	Antenna Polarization	EUT Face	Observations (Performance Criterion)	Result
80 MHz-2 GHz	10 V/m	400 Hz sine wave, 80 % AM, 1 % increment, dwell time=3seconds	V	Front	A	Pass
			H		A	Pass
			V	Rear	A	Pass
			H		A	Pass
			V	Left	A	Pass
			H		A	Pass
			V	Right	A	Pass
			H		A	Pass
			V	Top	A	Pass
			H		A	Pass
			V	Bottom	A	Pass
			H		A	Pass

Remark: A: No degradation in performance of the EUT was observed.

5.2.3. Fast transients (bursts)

PERFORMANCE CRITERION

Criteria B

TEST CONFIGURATION

AC Main / DC power input port:

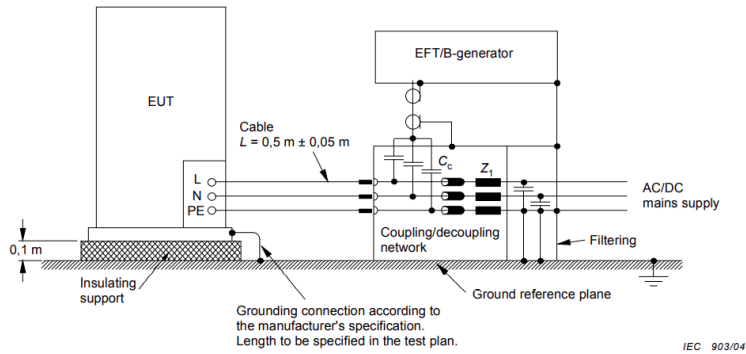

Telecommunication port:

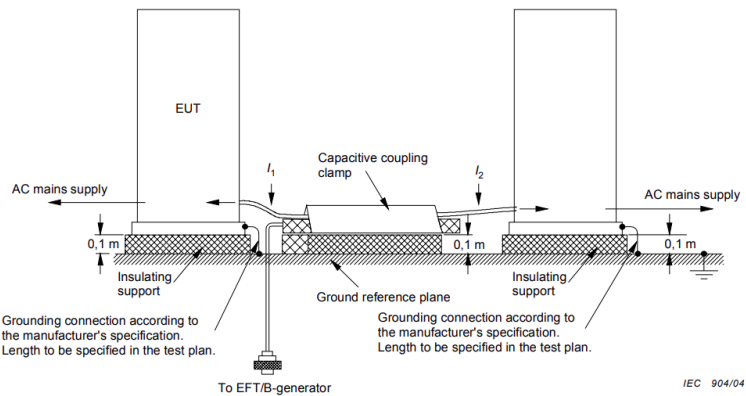

TEST PROCEDURE

Please refer to IEC60945 Clause 10.5.2 for the measurement methods

TEST MODE

Refer to the section 3.3

TEST RESULTS

Passed Not Applicable

Refer to the below test data:

Test mode:		All modes			
Port	Lead under Test	Coupling Direct / Clamp	Observations (Performance Criterion)	Criteria Level	Result
DC Power Port	Positive	Direct	# (A)	B	Pass
	Negative	Direct	# (A)	B	Pass

Note:

#: No degradation in performance of the EUT was observed

5.2.4. Slow transients (surges)

PERFORMANCE CRITERION

Criteria B

TEST CONFIGURATION

AC Main power input port:

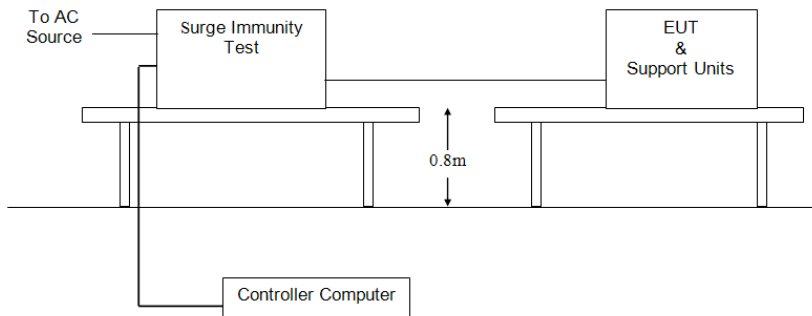

Telecommunication port:

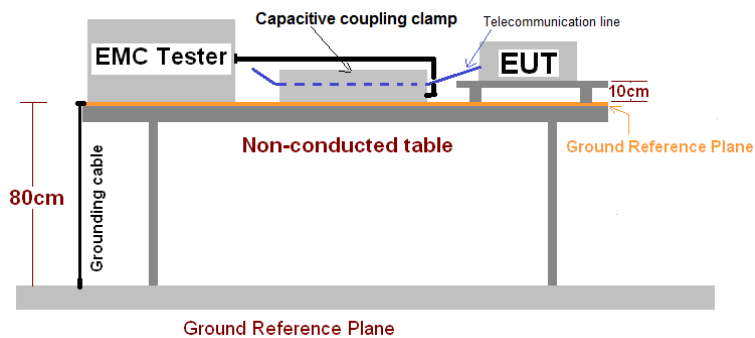

TEST PROCEDURE

Please refer to IEC60945 Clause 10.6.3 for the measurement methods

TEST MODE

Refer to the section 3.3

TEST RESULTS

Passed Not Applicable

Note:EUT belongs to DC power supply

5.2.5. Power supply transients

PERFORMANCE CRITERION

Criteria B

TEST CONFIGURATION

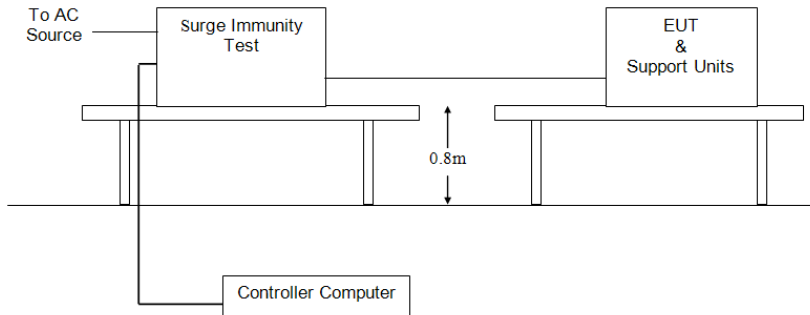

TEST PROCEDURE

Please refer to IEC60945 Clause 10.7.3 for the measurement methods

TEST MODE

Please reference to the section 3.3

TEST RESULTS

Passed Not Applicable

Note:EUT belongs to DC power supply

5.2.6. Power supply variations and failure

PERFORMANCE CRITERION

Criteria A for Power supply variations

Criteria C for Power supply failure

TEST CONFIGURATION

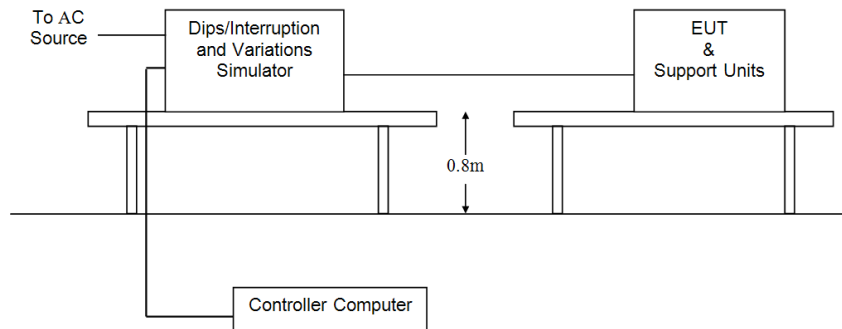

TEST PROCEDURE

Please refer to IEC60945 10.8.3 for the measurement methods

TEST MODE

Please reference to the section 3.3

TEST RESULTS

Passed Not Applicable

Note:EUT belongs to DC power supply

5.2.7. Electrostatic Discharge

PERFORMANCE CRITERION

Criteria B

TEST CONFIGURATION

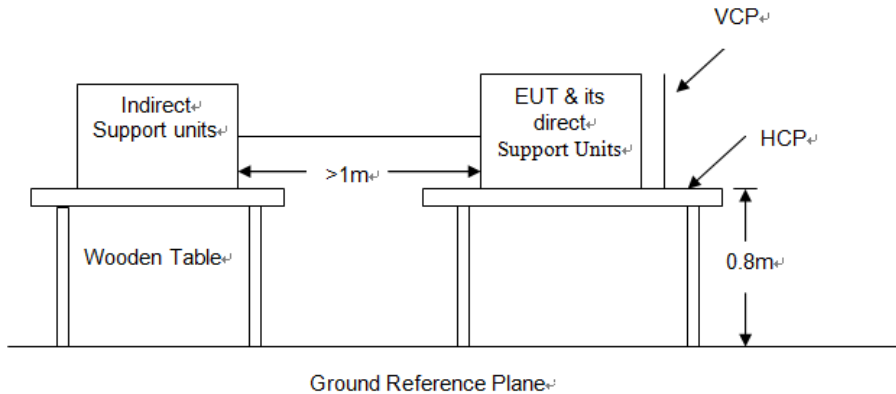

TEST PROCEDURE

Please refer to IEC60945 Clause 10.9.2 for the measurement methods

Contact Discharge:

The ESD generator is held perpendicular to the surface to which the discharge is applied and the tip of the discharge electrode touch the surface of EUT. Then turn the discharge switch. The generator is then re-triggered for a new single discharge and repeated at least 10 times for each pre-selected test point. This procedure shall be repeated until all the air discharge completed.

Air Discharge:

Air discharge is used where contact discharge can't be applied. The round discharge tip of the discharge electrode shall be approached as fast as possible to touch the EUT. After each discharge, the discharge electrode shall be removed from the EUT. The generator is then re-triggered for a new single discharge and repeated at least 10 times for each pre-selected test point. This procedure shall be repeated until all the air discharge completed.

Indirect discharge for horizontal coupling plane:

At least 10 single discharges shall be applied to the horizontal coupling plane, at points on each side of the EUT.

Indirect discharge for vertical coupling plane:

At least 10 single discharges shall be applied to the center of one vertical edge of the coupling plane. The coupling plane, of dimensions 0.5m X 0.5m, is placed parallel to, and positioned at a distance of 0.1m from the EUT. Discharges shall be applied to the coupling plane, with this plane in sufficient different positions that the four faces of the EUT are completely illuminated.

TEST MODE

Please reference to the section 3.3

TEST RESULTS

Passed Not Applicable

Test mode	All modes			
Direct discharge				
Type of discharge	Discharge voltage (kV)	Observations Performance	CriteriaLevel	Result
Contact discharge	±2	No degradation in performance of the EUT was observed (A)	B	Pass
	±4		B	
Air discharge	±2	B	B	
	±4	B	B	
	±8	B	B	
Indirect discharge				
Type of discharge	Discharge voltage (KV)	Observations Performance	CriteriaLevel	Result
HCP (6 sides)	±2	B	B	Pass
	±4	B	B	
VCP (4 sides)	±2	B	B	
	±4	B	B	

Description of Discharge Point

Contact discharge: →

Air discharge: →

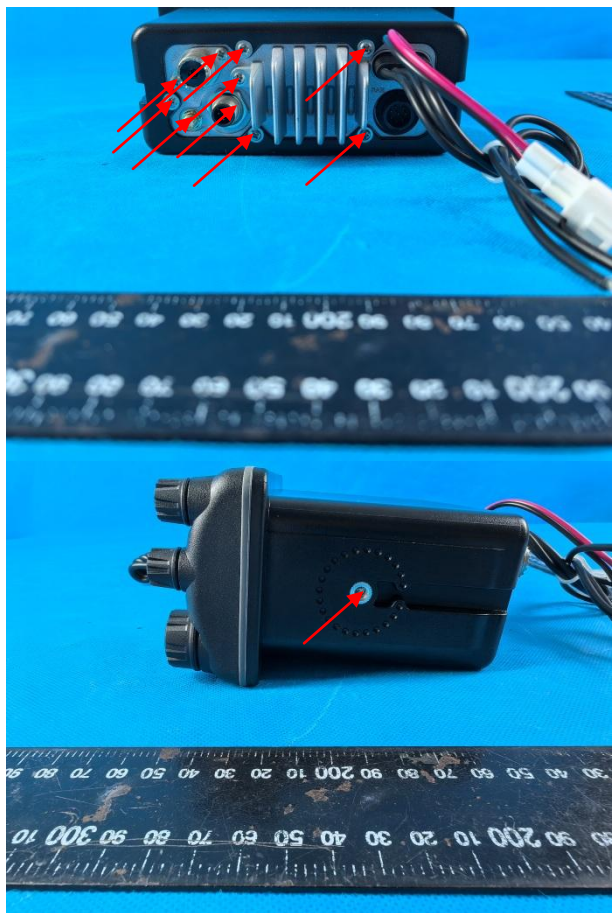



5.3. Environmental Test

5.3.1. Dry heat

TEST METHOD

Storage Test: The EUT shall be placed in a chamber at normal room temperature and relative humidity. The temperature shall then be raised to and maintained at $+70\text{ °C} \pm 3\text{ °C}$, for a period of 10 h to 16 h. At the end of the test, the EUT shall be returned to normal environmental conditions and then subjected to a performance check

Functional test: The EUT shall be placed in a chamber at normal room temperature and relative humidity. The EUT and, if appropriate, any climatic control devices with which it is provided shall then be switched on. The temperature shall then be raised to and maintained at $+55\text{ °C} \pm 3\text{ °C}$. At the end of a soak period of 10 h to 16 h at $+55\text{ °C} \pm 3\text{ °C}$, the EUT shall be subjected to a performance test and check.

The temperature of the chamber shall be maintained at $+55\text{ °C} \pm 3\text{ °C}$ during the whole performance test period. At the end of the test, the EUT shall be returned to normal environmental conditions.

TEST RESULTS

Passed Not Applicable

No degradation of performance or loss of function was observed.

5.3.2. Damp heat

TEST METHOD

Functional test: The EUT shall be placed in a chamber at normal room temperature and relative humidity. The temperature shall then be raised to $+40\text{ °C} \pm 2\text{ °C}$, and the relative humidity raised to $93\% \pm 3\%$ over a period of $3\text{ h} \pm 0,5\text{ h}$. These conditions shall be maintained for a period of 10 h to 16 h. Any climatic control devices provided in the EUT may be switched on at the conclusion of this period.

The EUT shall be switched on 30 min later, or after such period as agreed by the manufacturer, and shall be kept operational for at least 2 h during which period the EUT shall be subjected to a performance check as specified in the relevant equipment standard. The temperature and relative humidity of the chamber shall be maintained as specified during the whole test period. At the end of the test period and with the EUT still in the chamber, the chamber shall be brought to room temperature in not less than 1 h. At the end of the test the EUT shall be returned to normal environmental conditions.

TEST RESULTS

Passed Not Applicable

No degradation of performance or loss of function was observed.

5.3.3. Low temperature

TEST METHOD

Functional test: The EUT shall be subject to the conditions specified for portable equipment except that the temperature of the chamber shall be reduced to, and maintained at $-15\text{ °C} \pm 3\text{ °C}$. The EUT shall be switched on 30 min later, or after such period as agreed by the manufacturer, and shall be kept operational for at least 2 h during which period the EUT shall be subjected to a performance check test and check

TEST RESULTS

Passed Not Applicable

No degradation of performance or loss of function was observed.

5.3.4. Vibration

TEST METHOD

The EUT, complete with any shock and vibration absorbers with which it is provided, shall be fastened to the vibration table by its normal means of support and in its normal attitude. The EUT may be resiliently suspended to compensate for weight not capable of being withstood by the vibration table. Provision may be made to reduce or nullify any adverse effect on EUT performance which might be caused by the presence of an electromagnetic field due to the vibration unit.

The EUT shall be subjected to sinusoidal vertical vibration at all frequencies between:

– 2 Hz to 5 Hz and up to 13,2 Hz with an excursion of $\pm 1\text{ mm} \pm 10\%$

(7 m/s² maximum acceleration at 13,2 Hz);

– above 13,2 Hz and up to 100 Hz with a constant maximum acceleration of 7 m/s².

The frequency sweep rate shall be 0,5 octaves/min in order to allow the detection of resonances in any part of the EUT as mounted.

A resonance search shall be carried out throughout the test. During the resonance search the EUT shall be externally observed, by unaided visual and aural means, for obvious signs of any resonances of components or sub-assemblies, that may affect the integrity of the EUT. Such observations shall be recorded in the test report. If any resonance, as measured by a sensor fixed to the outside of the EUT at the location where obvious signs of resonance have been observed, has a magnitude ratio ≥ 5 measured relative to the surface where the EUT is fastened, the EUT shall be subjected to a vibration endurance test at each resonant frequency at the vibration level specified in the test with a duration of 2 h. When resonant frequencies with magnitude ratios ≥ 5 are harmonically related, only the fundamental frequency shall be tested. If no resonance with a magnitude ratio ≥ 5 occurs, the endurance test shall be carried out at one single observed frequency. If no resonance occurred, the endurance test shall be carried out at a frequency of 30 Hz. Performance check(s) shall be carried out at least once during each endurance test period, and once before the end of each endurance test period.

TEST RESULTS

Passed Not Applicable

No degradation of performance or loss of function was observed.

6. Test Setup Photos

Radiated Emission

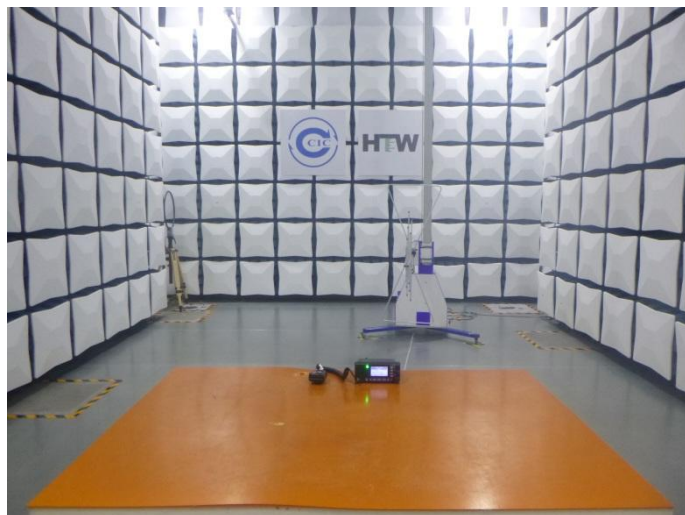
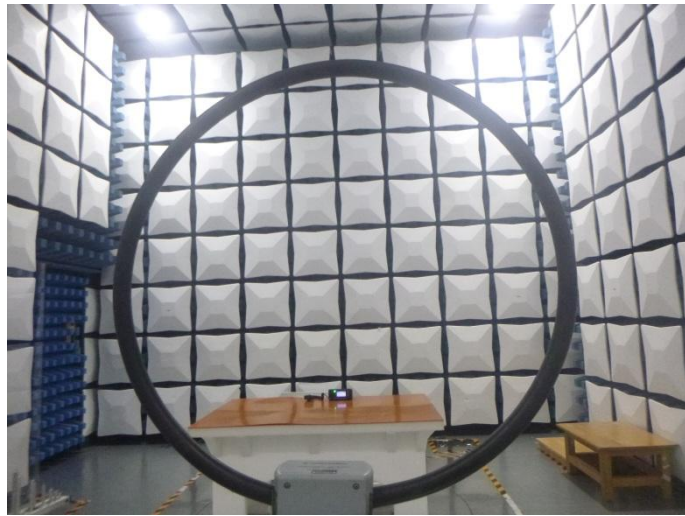

Conducted Emission





Electrostatic Discharge



Conducted radio frequency disturbance

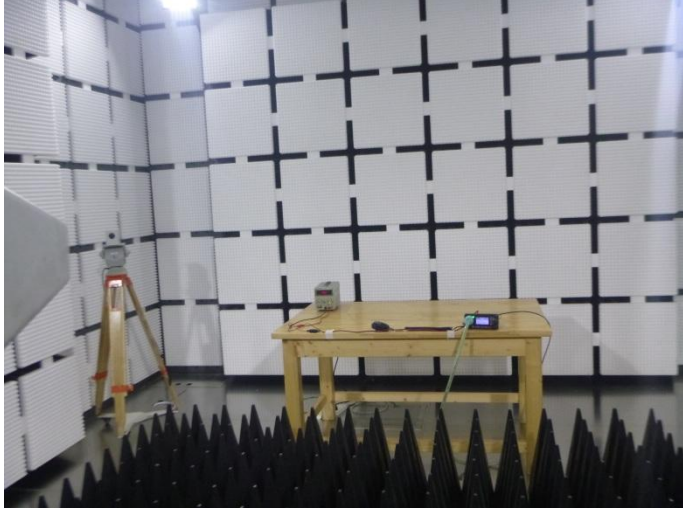

<p>Radiated disturbance</p>	
<p>Fast transients (bursts)</p>	

7. External and Internal Photos of the EUT

Reference to the test report No.: CHTW24070080

-----End of Report-----