

YAESU
The radio

DUAL BAND FM TRANSCEIVER

FTM-6000R
FTM-6000E

Operating Manual



Contents

Introduction	1	Scanning Function	26
About this manual	1	VFO Scan / Memory Scan / PMG Scan.....	26
Basic Operation	2	Programmable Memory scan (PMS).....	26
Turning the Transceiver ON	2	Setting the Receive Operation	
Adjusting the volume	2	When Scanning Stops.....	27
Adjusting the squelch level.....	2	Skip Memory Channels	27
Selecting a Frequency Band	2	Convenience Features	28
Tuning to a Frequency.....	3	Bluetooth® Operation	
Transmitting	3	(Requires optional BU-4).....	28
Locking the Keys and DIAL knob	3	Changing the Frequency Step.....	33
E2O-III (Easy to Operate-III) Provides the		Changing the Transmit Power Level	33
Choice of 3 Operating Modes to assign		Tone squelch feature.....	34
Functions & Settings	4	Digital Code squelch (DCS) feature.....	34
[F1] key.....	4	PAGER (EPCS) feature.....	34
Function List	4	Automatic Range Transponder System	
Menu List (see page 6).....	4	(ARTS).....	34
MAG (Memory Auto Grouping) function	5	Using Menu List	35
PMG (Primary Memory Group) function	5	Menu List Operation	35
VFO Band Skip function	5	Tables of Menu list Operations	36
Moving Memory Data to the VFO register ...	5	Restoring to Defaults (All Reset)	38
Supplied Accessories and Options	7	Specifications	39
Supplied Accessories.....	7	YAESU LIMITED WARRANTY	41
Available Options.....	7		
Name and function of each component	8		
Panel (front).....	8		
Panel (Rear, Left and right side).....	11		
Main body (Front and Rear)	11		
Microphone (SSM-85D)	12		
Safety Precautions (Be Sure to Read)	13		
Installing the Radio	15		
About the antenna	15		
Connection of Antenna and Power Cables ..	15		
Installing the transceiver	16		
Connecting the front panel to the			
main body	16		
Repeater Operation	17		
Communicating Via the Repeater	17		
Using the Memory	18		
Writing to memory	18		
Recall memory	19		
Recall only memories in the			
same frequency band (Band) using the			
memory auto grouping (MAG) function.....	20		
PMG (Primary Memory Group).....	21		
To Append an Alpha-numeric			
“Tag” to a Memory	22		
Clearing Memories	23		
Copying Memories	23		
Recalling the Home Channel	24		
Changing the Home Channel Frequency....	25		

Features of the Yaesu FTM-6000R/E Transceiver.

- New “E2O-III (Easy to Operate-III)” implements 3 function lists to allow calling up frequently used settings during operation with a single touch.
- The PMG (Primary Memory Group) function allows recalling a group of registered frequencies regardless of frequency band.
- Memory Channel Band Auto Grouping (MAG). The memory channels are automatically categorized in each band, so that memory channels can be easily and quickly recalled.
- Wide-band reception (108 MHz to 999.995 MHz) (USA Cellular Blocked)
- When the optional BU-4 Bluetooth® Unit is installed, supports hands-free communication using the optional Bluetooth® headset SSM-BT10 or a commercially available product.
- Large-capacity 1100 memory channels
- 3W Audio Power Speaker
- Heavy Duty-Heat Sink with FACC (Funnel Air-Convection Conductor)

Thank you for purchasing the FTM-6000R/E Transceiver. We urge you to read this manual in its entirety, and also the Advance Manual (available for download on the Yaesu website), to gain a full understanding of the amazing capability of the exciting new FTM-6000R/E Transceiver.

About this manual

The following notation is also used in this manual.



This icon indicates cautions and information that should be read.



This icon indicates notes, tips and information that should be read.

PLEASE NOTE: Due to product improvements, some of the illustrations in the instruction manual may differ from the actual product.

Basic Operation

Turning the Transceiver ON

1. Press and hold the Power (Lock) switch to turn the transceiver ON.

● Turning the transceiver OFF

Press and hold the Power (Lock) switch again to turn the transceiver OFF.

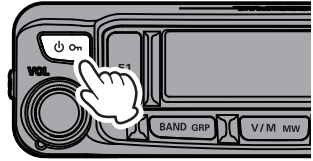

Adjusting the volume

1. Rotate the **DIAL** knob to adjust the volume to a comfortable level.

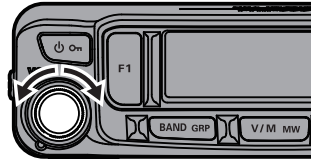

Adjusting the squelch level

Annoying noises can be muted when a signal cannot be detected. Normally, use the factory settings, but adjust the squelch if noise is harsh.

1. Press the [**SQL BACK**] key, and then rotate the **DIAL** knob to adjust to a level at which the background noise is muted.
2. After the adjustment, press the [**SQL BACK**] key again, or do nothing for about 2 seconds, the SQL meter will return to the normal screen.

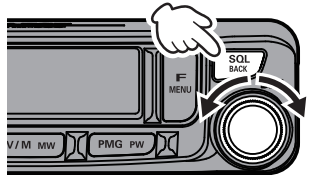

When the squelch level is increased, the noise is more likely to be silenced, but it may become more difficult to receive weak signals.

Selecting a Frequency Band

Press the [**BAND GRP**] key to select the desired frequency band.

AIR Band	108MHz - 137MHz
144MHz Band	137MHz - 174MHz
VHF Band	174MHz - 400MHz
430MHz Band	400MHz - 480MHz
UHF Band	480MHz - 999.995MHz

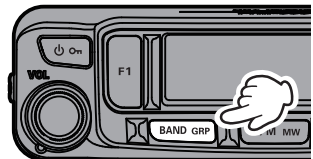

Unwanted frequency bands can be set in the menu list so they are not displayed. Press and hold the [**F MENU**] key → Rotate the **DIAL** knob to select [**18 BND.SEL**] → Press the **DIAL** knob → Rotate the **DIAL** knob to select a band → Press the **DIAL** knob → Rotate the **DIAL** knob to select ON or OFF.

Tuning to a Frequency

● DIAL knob

Rotating the **DIAL** knob changes the frequency in the optimal frequency step for the current frequency band.

Change frequency in 1MHz steps

Press the **DIAL** knob, and then rotate the **DIAL** knob.

Change frequency in 5MHz steps

Press and hold the **DIAL** knob, and then rotate the **DIAL** knob.

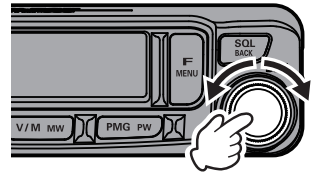

● The numeric keys on microphone

Press the numeric keys "0" to "9" to enter the frequency.

Example: To input 145.520MHz

[1] → [4] → [5] → [5] → [2]

Example: To input 430.000MHz

[4] → [3] → [Press and hold any numeric key]

i While entering a frequency using the numeric keys, the entry may be canceled by pressing the **PTT** switch.

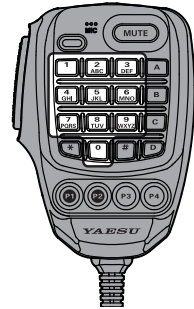

Transmitting

1. While pressing and holding the **PTT** switch, speak into the microphone. When transmitting, the "**TX**" icon appears on the display.
2. Release the **PTT** switch to return to receive mode. When receiving a signal, the "**BUSY**" icon appears on the display.

- If the PTT switch is pressed when a frequency other than an amateur ham radio band is selected, an alarm tone (beep) will be emitted and "Inhbt" appears on the display, disabling transmission.
- If transmission is continued for a long period, the transceiver overheats, and the high temperature protection function is activated. As a result, the transmitting power level is automatically set to Low Power. If transmission continues while the high temperature protection function is active, the transceiver will be forcibly returned to the receive mode.

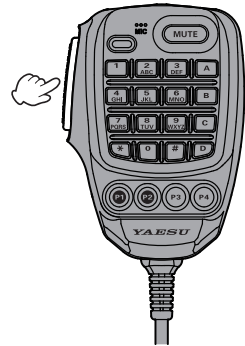

Locking the Keys and DIAL knob

1. Press the Power (Lock) switch, "**LOCK**" is shown on the display for one second, and then the keys and **DIAL** knob are locked.

i The **PTT** switch and the **VOL** knob cannot be locked.

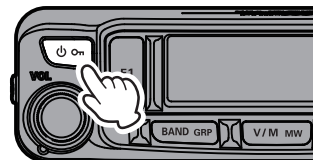

2. Press the **POWER** (Lock) switch again, "**UNLOCK**" is shown on the display and the keys and the **DIAL** knob are unlocked.

E2O-III (Easy to Operate-III) Provides the Choice of 3 Operating Modes to assign Functions & Settings

- ① “[F1] key” assigns the most frequently used function.
- ② “Function list” assigns frequently used functions.
- ③ “Menu list” to make all settings.

① [F1] key

From the list, the function with the highest priority can be registered to the [F1] key, then it can be called directly by simply pressing the [F1] key.

• Change the assignment of the [F1] key

Select the function or item to assign from the function list, then press and hold the [F1] key.

Press and hold: Assign to [F1] key
Press briefly: Recall and execute



② Function List

Register frequently used items from the 34 functions on the menu list (see page 6). To recall a function, press the [F MENU] key, then turn the **DIAL** knob.

• Registration to function list

Select the function or item to assign from the menu list, then press and hold the [F MENU] key.

• Cancel registration to function list

Select the function or item to cancel, then press and hold the [SQL BACK] key.

The function is canceled from the function list and returns to the menu list.

Press and hold: Assign to Function List
Press briefly: Recall the Function List

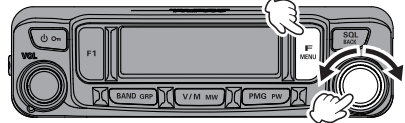

Rotate the DIAL knob to select

Press and hold: Unregister the Function



③ Menu List (see page 6)

To select all functions and items other than those registered to the frequently used function list, press and hold the [F MENU] key, then rotate the **DIAL** knob.

Press and hold: Recall the Menu List

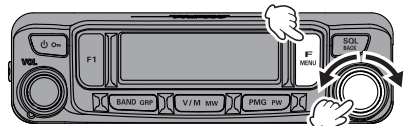

Rotate the DIAL knob to select

④ MAG (Memory Auto Grouping) function

Memory channels can be easily grouped and recalled by band. Each time the [BAND GRP] key is pressed while operating in memory mode, the bands are switched in the order illustrated below. Only the memory channels in that frequency band can be automatically grouped and recalled.

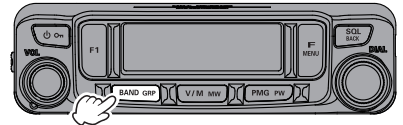

Press in memory mode to switch bands

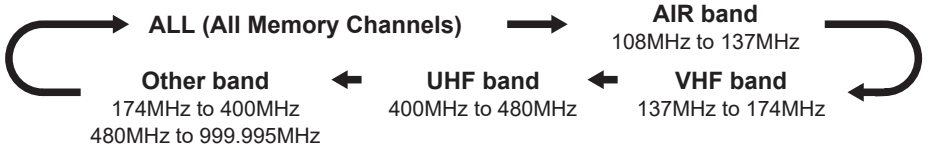

⑤ PMG (Primary Memory Group) function

Frequently used frequencies that have been registered in PMG, can be displayed in an easy-to-understand manner simply by pressing the [PMG PW] key.

• Register the frequency to PMG

Set the frequency, or the memory channel to register, then press and hold the [PMG PW] key to register it in PMG.

• Unregister the channel (frequency) registered in PMG

During PMG operation, select the frequency (channel) to be unregistered, then press and hold the [PMG PW] key to cancel the registration of that frequency.

Rotate the DIAL knob to select

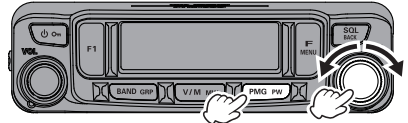

Press and hold: Register or Unregister
Press briefly: Enable or Disable PMG



Up to 5 channels can be registered in PMG. To register a new frequency, cancel one of the registered frequencies and then register the new frequency.

⑥ VFO Band Skip function

The VFO band selection is enabled by pressing the [BAND GRP] key. Also, unused bands may be skipped.

• Set the band to be skipped

Press and hold the [F MENU] key → Rotate the **DIAL** knob to select [18 BND. SEL] → Press the **DIAL** knob → Rotate the **DIAL** knob to select a band → Press the **DIAL** knob → Rotate the **DIAL** knob to select ON or OFF.

Press and hold: Recall the Menu List

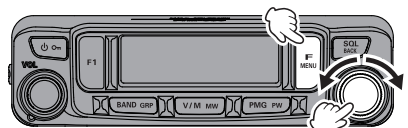

Rotate the DIAL knob to select

⑦ Moving Memory Data to the VFO register

The contents of the currently selected Memory Channel may be transferred into the VFO register. Press and hold the [SQL BACK] key while the memory channel is displayed.

Press and hold: Memory Channel transfer into the VFO

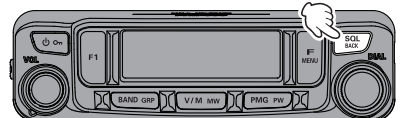

Menu List

The items in the gray are pre-registered in the "Function list", Press the [**F MENU**] key to call the "Function list".

01 APO	Enables/Disables the Automatic Power Off feature
02 AR MOD	Select the ARTS Beep mode
03 AR INT	Select the Polling Interval during ARTS operation
04 BCLO	Enables/Disables the Busy Channel Lock-Out feature
05 BEEP	Set the beep level
06 BELL	Select the CTCSS/DCS/EPCS Bell Ringer repetitions
07 CLK.TYP	Shifts of the CPU clock frequency
08 DIMMER	Set the front panel display illumination level
09 DTMF	Enables/Disables the DTMF Autodialer feature
10 DT TX	Load the DTMF Autodialer Memories.
11 DT MEM	Register a DTMF code
12 HOME	Recall the home channel
13 MIC.GIN	Adjust the microphone gain level
14 MIC.PGM	Program the functions assigned to the Microphone keys [P1], [P2], [P3] & [P4]
15 PAGER	Set the Receive/Transmit Pager Code for Enhanced CTCSS Paging & Code Squelch functions
16 PKT.SPD	DATA communication baud rate settings
17 RX MODE	Select the receive mode
18 BND.SEL	Set the frequency bands that can be selected

19 RPT.REV	Reverses the transmit and receive frequencies while working through a repeater.
20 RPT.SET	Set the Repeater Shift direction
21 RPT.OTR	• Set the ARS (Automatic Repeater Shift) • Set the Repeater Shift
22 SCN.ON	Engages the Scan operation
23 SCN.TYP	• Select the Scan Resume mode • Set the "Primary Channel Revert" feature
24 SQL.TYP	Selects the Tone Encoder and/or Decoder mode.
25 SQL.COD	Set the CTCSS Tone Frequency or DCS code.
26 SQL.EXP	Enable or disables split CTCSS/DCS coding
27 STEP	Set the frequency synthesizer steps
28 xx.xF (C)	Display the current temperature inside the transceiver
29 TOT	Set the Time-Out Timer
30 TX PWR	Set the transmit power level.
31 VER.DSP	Display the transceiver software version
32 xx.xV	Display the DC Supply Voltage.
33 WIDTH	Set the FM transmit modulation level and receiver bandwidth
34 WX ALT	Weather alert operation setting
35 BLT	Set the Bluetooth function

Supplied Accessories and Options

Supplied Accessories

- DTMF microphone SSM-85D
- DC power cable (with fuse attached)
- Control cable
- Control cable 10ft (3m)
- Bracket for main body
- Bracket for the controller
- USB Cable
- Spare fuse (15A)
- Operating Manual (This Manual)



If any item is missing, contact the dealer from which you purchased the transceiver.

Available Options

- | | |
|--------------------------------------------------------|----------|
| • DTMF Microphone | SSM-85D |
| • Microphone | MH-42C6J |
| • Bluetooth® Headset | SSM-BT10 |
| • Bluetooth® Unit | BU-4 |
| • High-Power External Speaker | MLS-100 |
| • Vacuum Cup Mount Bracket for Front Panel Controller | MMB-98 |
| • Mic Extension Kit 10ft (3m) for SSM-85D and MH-42C6J | MEK-5 |
| • Control Cable 20ft (6m) | SCU-47 |
| • Cloning Cable | CT-166 |
| • Data Cable (MDIN10 pin to MDIN6 pin + Dsub9) | CT-163 |
| • Data Cable (MDIN10 pin to MDIN6 pin) | CT-164 |
| • Data Cable (MDIN10 pin to Dsub9) | CT-165 |
| • Data Cable (MDIN10 pin to Open) | CT-167 |

Name and function of each component

Panel (front)

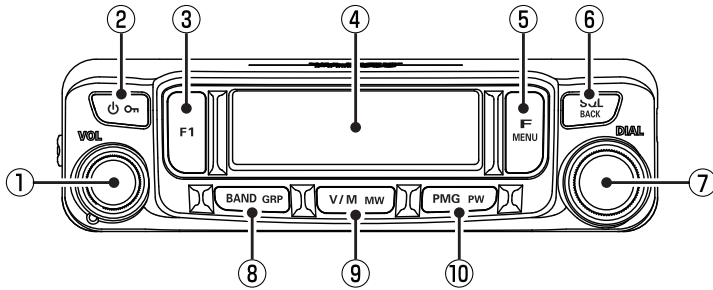

① VOL knob

Rotate the VOL Knob to adjust the audio volume level.

② POWER (On/Off) Switch

Press and hold this button to switch the power ON or OFF.

When the power is ON, press this button briefly to engage, or release the key lock.

③ [F1] key

The [F1] key is user programmable, allowing quick access to the Function or Menu item that is most often used. The factory default setting is "HOME" (calls the home channel).

To change to another item, press the [F MENU] key, and then rotate the DIAL knob to select the desired item, and press and hold the [F1] key.

④ LCD display

1~5 : PMG Memory Number

F : Function List

R : AIR band*1 memory channels only

V : VHF band*2 memory channels only

U : UHF band*3 memory channels only

D : Other band*4 memory channels only

*1 108MHz to 137MHz

*2 137MHz to 174MHz

*3 400MHz to 480MHz

*4 174MHz to 400MHz

480MHz to 999.995MHz

001~999 : Memory Channel Number

LO1~US0 : Programmable Memory Channel Number

PO1~PS0 : Programmable Memory Scan

HM : HOME Channel

PM : PMG Memory

DCS (Digital Code Squelch)

Repeater Shift Direction

CTCSS Operation

Memory Mode

- Frequency/Message area
- Memory Tag area
- Menu List
- Function List



Bluetooth function

Appears: Bluetooth Device is connected

Blinks: Bluetooth Device not connected

Transmission in Progress

⑤ **[F MENU] key**

Press briefly

Press the **[F MENU]** key to display the function list screen. Rotate the **DIAL** knob to select an item and perform the functions and make settings.

In the factory default setting, the items in gray of the table below are registered to the function list. The registration can be canceled at any time.

Add registration: Press and hold the **[F MENU]** key → Turn the **DIAL** knob to select the item to register → Press and hold the **[F MENU]** key.

Cancel registration: Turn the **DIAL** knob to select the registered item to cancel → Press and hold the **[SQL BACK]** key.

Press and hold

Press and hold the **[F MENU]** key to enter the menu list. The Menu list permits configuring the various functions according to individual operating needs and preferences. (Refer to page 35).

The items in gray are registered to the “function list” in advance, briefly press the **[F MENU]** key to call them.

Menu list

01 APO	Enables/Disables the Automatic Power Off feature
02 AR MOD	Select the ARTS Beep mode
03 AR INT	Select the Polling Interval during ARTS operation
04 BCLO	Enables/Disables the Busy Channel Lock-Out feature
05 BEEP	Set the beep level
06 BELL	Select the CTCSS/DCS/EPCS Bell Ringer repetitions
07 CLK.TYP	Shift the CPU clock frequency
08 DIMMER	Sets of the front panel display illumination level
09 DTMF	Enables/Disables the DTMF Autodialer feature
10 DT TX	Loads the DTMF Autodialer Memories.
11 DT MEM	Register a DTMF code
12 HOME	Recall the home channel
13 MIC.GIN	Adjust the microphone gain level
14 MIC.PGM	
PGM.P1	Program the function assigned to the Microphone [P1] key
PGM.P2	Program the function assigned to the Microphone [P2] key
PGM.P3	Program the function assigned to the Microphone [P3] key
PGM.P4	Program the function assigned to the Microphone [P4] key
15 PAGER	
PAG.CDR	Set the Receive Pager Code for Enhanced CTCSS Paging & Code Squelch functions
PAG.CDT	Set the Transmit Pager Code for Enhanced CTCSS Paging & Code Squelch functions
16 PKT.SPD	DATA communication baud rate settings
17 RX MODE	Select the receive mode
18 BND.SEL	Set the frequency bands that can be selected

19 RPT.REV	Reverses the transmit and receive repeater offset frequencies.
20 RPT.SET	Set the Repeater offset frequency Shift direction
21 RPT.OTR	
RPT.ARS	Activate/Deactivate the Automatic Repeater Shift feature
RPT.FRQ	Set the magnitude of the Repeater Shift
22 SCN.ON	Engages the Scan operation
23 SCN.TYP	
SCN.RSM	Select the Scan Resume mode
DW RVT	Enables/Disables the “Primary Channel Revert” feature.
24 SQL.TYP	Selects the Tone Encoder and/or Decoder mode.
25 SQL.COD	Setting of the CTCSS Tone Frequency or the DCS code.
26 SQL.EXP	Enables/Disables the split CTCSS/DCS coding
27 STEP	Sets the frequency synthesizer steps
28 xx.xF	Indicates the current temperature inside the transceiver
29 TOT	Set the Time-Out Timer
30 TX PWR	Set the transmit power level.
31 VER.DSP	Display the transceiver software version
32 xx.xV	Display the DC Supply Voltage.
33 WIDTH	Set the FM transmit modulation level and receiver bandwidth
34 WX ALT	Weather alert operation setting
35 BLT	
BLT.OFF	Set the Bluetooth function
BLT.LST	Bluetooth device list
BLT.SAV	Set the Bluetooth save function
BLT.AF	Set the Bluetooth receive audio output

⑥ **[SQL BACK] key**

- Press the **[SQL BACK]** key, then rotate the **DIAL** knob to adjust the squelch level. The squelch level may be adjusted to mute the background noise when no signal is present.
- Press the **[SQL BACK]** key to return to the previous screen.
- If the **[SQL BACK]** key is pressed and held while the memory channel is displayed, the information registered in the memory channel at that time will be switched to VFO mode.

⑦ **DIAL knob**

Change the frequency or select the memory channel.

- Press the **DIAL** knob to enable setting the operating band frequency in 1MHz units.
- Press and hold the **DIAL** knob to enable setting the frequency in 5MHz units.
- Press the **[SQL BACK]** key, then rotate the **DIAL** knob to adjust the squelch level.

⑧ **[BAND GRP] key**

VFO mode





Each key press switches the operating frequency band.

Band	Selectable Frequency Range
AIR	108MHz - 137MHz
144MHz	137MHz - 174MHz
VHF	174MHz - 400MHz
430MHz	400MHz - 480MHz
UHF	480MHz - 999.95MHz

Memory mode

Each time the **[BAND GRP]** key is pressed, only memory channels of the same frequency band are automatically recalled as a group as shown below.

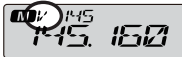
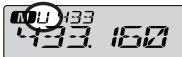
Bands that have not been stored are not displayed.

Group Name	Selectable Memory Channels
ALL No icon display 	All memory channels.
AIR "A" icon blink 	AIR band (108MHz to 137MHz) memory channels only.
VHF "V" icon blink 	VHF band (137MHz to 174MHz) memory channels only.
UHF "U" icon blink 	UHF band (400MHz to 480MHz) memory channels only.
Other "O" icon blink 	174MHz to 400MHz and 480MHz to 999.995MHz memory channels only.

⑨ **[V/M mw] key**

Press briefly

- Pressing each time switches between VFO mode and memory mode.
- When a memory channel is recalled, the "**M**" icon and the memory channel number are displayed, such as "001". The last operated memory channel is recalled.

Press and hold

Press and hold for over one second to write to memory.

⑩ **[PMG pw] key**

Press briefly

Each press each time switches between PMG (Primary Memory Group) mode and memory or VFO mode.

Press and hold

Press and hold for over one second to write to PMG memory.

Panel (Rear, Left and right side)

DATA jack

When updating the panel firmware, connect to the PC with the supplied USB cable.

Please refer to YAESU website for firmware updates.

CONTROL jack

Plug the control cable into this jack to connect with the main body.

Press to release the control panel from the transceiver.

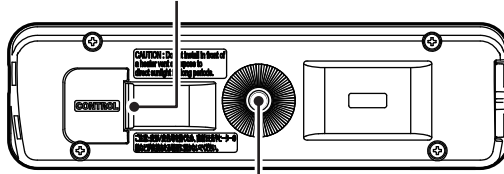
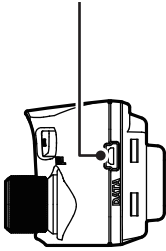

Attach the supplied panel bracket or the optional adjustable angle suction type control panel bracket MMB-98 with the supplied screws.

Main body (Front and Rear)

MIC jack

Connect the cable of the included DTMF microphone SSM-85D or the optional microphone MH-42C6J.

CONTROL jack

Plug the control cable into this jack to connect with the control panel.

DATA jack

When updating the Main firmware, connect to the PC with the supplied USB cable.

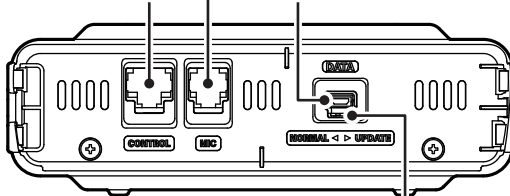

Connecting the front panel to the main body

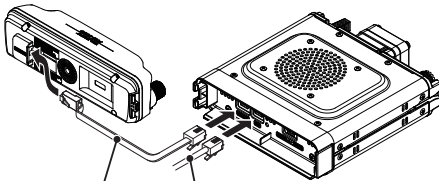

Control cable Microphone cable

Firmware Update switch

This switch is used when updating the Main firmware. Normally set to "NORMAL" position.

Please refer to YAESU website for firmware updates.

Connect the provided DC power supply cable (with fuse attached).

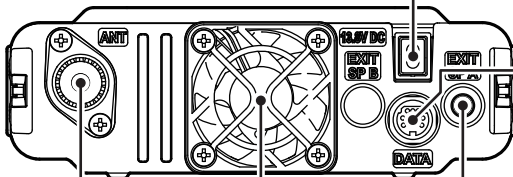

Connect the co-axial cable for the antenna.

Cooling fan

This 2-conductor, 3.5-mm mini phone jack provides audio output for an optional speaker. The optimum load impedance is 8 Ohms.

Microphone (SSM-85D)

① MIC

Speak into the microphone during transmission.

② TX LED

Lights red while pressing PTT switch.

③ PTT

Press and hold the PTT switch to transmit, and release it to receive.

④ DWN

Press this button to move the frequency or memory channel lower by one step, press and hold it to start scanning.

⑤ UP

Press this button to move the frequency or memory channel up by one step, press and hold it to start scanning.

⑥ MUTE

Press this button to mute the receive audio. Press it again to unmute the audio.

⑦ DTMF keypad

Press these keys during transmit to enter and send a DTMF sequence. The following operations can be performed during receive.

0 - 9 : Enter the frequency or memory channel number.

A : Change frequency in 1MHz steps

B : Adjust the squelch level.

C : Each key press switches between PMG (Primary Memory Group) mode and memory or VFO mode.

D : Each key press switches between Function list mode and memory or VFO mode.

* : Each press switches between VFO mode and memory mode.

: This key has the same function as the **[BAND GRP]** key on the controller.

VFO mode:

Each press changes the operating frequency band:

→ AIR (108MHz to 137MHz) → 144MHz (137MHz to 174MHz) → VHF (174MHz to 400MHz) →
→ 430MHz (400MHz to 480MHz) → UHF (480MHz to 999.995MHz) → AIR

Memory mode:

Each time the key is pressed only memory channels of the same frequency band are automatically recalled as a group, as shown below:

→ ALL → AIR (108MHz to 137MHz) → VHF (137MHz to 174MHz) → UHF (400MHz to 480MHz) →
→ Other (174MHz to 400MHz and 480MHz to 999.995MHz) → ALL

* Bands that have not been stored are not displayed.

⑧ Program keys (P1/P2/P3/P4)

The default function settings of the [P1] / [P2] / [P3] / [P4] keys are shown in the table below.

Key	Function	Description
P1	SQL OFF	Opens the squelch (SQL off)
P2	HOME	Recalls HOME channel
P3	SCN ON	Starts or stops the scanning function
P4	WX (T-CALL)	Switches operation to the Weather Channel Bank (T-CALL: European/Asian versions)

The functions of the [P1] - [P4] keys can be assigned by the following operations:

1. Press and hold the **[F MENU]** key.
2. Rotate the **DIAL** knob to select **[14 MIC.PGM]**, then press the **DIAL** knob.
3. Rotate the **DIAL** knob to select a key to assign a function **[PGM.P1] - [PGM.P4]** then press the **DIAL** knob.
4. Rotate the **DIAL** knob to select a function (see the table below) then press the **DIAL** knob.

Function	Description
ARTS	Starts or stops the ARTS function
SCN ON	Starts or stops the scanning function
HOME	Recalls the HOME channel
RPT.SFT	Sets the repeater shift direction
RPT.REV	Reverses the transmit and receive frequencies in repeater mode or split memory

Function	Description
TX PWR	Selects the transmit power output level
SQL OFF	Opens the squelch (SQL OFF)
T-CALL	Transmits the T-CALL (1750 Hz)
DW	Starts or stops the Dual Watch function
WX	Switches operation to the Weather Channel Bank

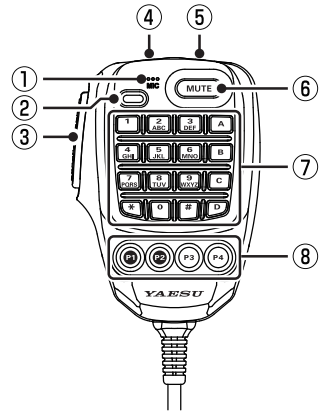

Safety Precautions (Be Sure to Read)

Be sure to read these important precautions, and use this product safely.

Yaesu is not liable for any failures or problems caused by the use or misuse of this product by the purchaser or any third party. Also, Yaesu is not liable for damages caused through the use of this product by the purchaser or any third party, except in cases where ordered to pay damages under the laws.

Types and meanings of the marks



DANGER

This mark indicates an imminently hazardous situation, which, if not avoided, could result in death or serious injury.



WARNING

This mark indicates a potentially hazardous situation, which, if not avoided, could result in death or serious injury.



CAUTION

This mark indicates a potentially hazardous situation, which, if not avoided, may result in minor or moderate injury or only property damage.

Types and meanings of symbols



These symbols signify prohibited actions, which must not be done to use this product safely. For example:  indicates that the product should not be disassembled.



These symbols signify required actions, which must be done to use this product safely. For example:  indicates that the power plug should be disconnected.



DANGER



Do not use the device in “regions or aircrafts and vehicles where its use is prohibited” such as in hospitals and airplanes.

This may exert an impact on electronic and medical devices.



Do not use this product while driving or riding a motorbike. This may result in accidents.

Make sure to stop the car in a safe location first before use if the device is going to be used by the driver.



Do not operate the device when flammable gas is generated.

Doing so may result in fire and explosion.



Never touch the antenna during transmission.

This may result in injury, electric shock and equipment failure.



Do not transmit in crowded places in consideration of people who are fitted with medical devices such as heart pacemakers.

Electromagnetic waves from the device may affect the medical device, resulting in accidents caused by malfunctions.



When an alarm goes off with the external antenna connected, cut off the power supply to this radio immediately and disconnect the external antenna from this radio.

If not, this may result in fire, electric shock and equipment failure.



Do not touch any liquid leaking from the liquid display with your bare hands.

There is a risk of chemical burns occurring when the liquid comes into contact with the skin or gets into the eyes. In this case, seek medical treatment immediately.



WARNING



Do not use voltages other than the specified power supply voltage.

Doing so may result in fire and electric shock.



Do not transmit continuously for long periods of time.

This may cause the temperature of the main body to rise and result in burns and failures due to overheating.



Do not dismantle or modify the device.

This may result in injury, electric shock and equipment failure.



Do not handle the power plug and connector etc. with wet hands. Also do not plug and unplug the power plug with wet hands.

This may result in injury, liquid leak, electric shock and equipment failure.



When smoke or strange odors are emitted from the radio, turn off the power and disconnect the power cord from the socket.

This may result in fire, liquid leak, overheating, damage, ignition and equipment failure. Please contact our company amateur customer support or the retail store where you purchased the device.



Keep the power plug pins and the surrounding areas clean at all times.

This may result in fire, liquid leak, overheating, breakage, ignition etc.





Disconnect the power cord and connection cables before incorporating items sold separately and replacing the fuse.

This may result in fire, electric shock and equipment failure.

 **Never cut off the fuse holder of the DC power cord.**
This may cause short-circuiting and result in ignition and fire.

 **Do not use fuses other than those specified.**
Doing so may result in fire and equipment failure.

 **Do not allow metallic objects such as wires and water to get inside the product.**
This may result in fire, electric shock and equipment failure.

 **Do not place the device in areas that may get wet easily (e.g. near a humidifier).**
This may result in fire, electric shock and equipment failure.

 **When connecting a DC power cord, pay due care not to mix up the positive and negative polarities.**
This may result in fire, electric shock and equipment failure.

 **Do not use DC power cords other than the one enclosed or specified.**
This may result in fire, electric shock and equipment failure.

 **Do not bend, twist, pull, heat and modify the power cord and connection cables in an unreasonable manner.**
This may cut or damage the cables and result in fire, electric shock and equipment failure.

 **Do not pull the cable when plugging and unplugging the power cord and connection cables.**
Please hold the plug or connector when unplugging. If not, this may result in fire, electric shock and equipment failure.

 **Refrain from using headphones and earphones at a loud volume.**
Continuous exposure to loud volumes may result in hearing impairment.

 **Do not use the device when the power cord and connection cables are damaged, and when the DC power connector cannot be plugged in tightly.**
Please contact our company amateur customer support or the retail store where you purchased the device as this may result in fire, electric shock and equipment failure.

 **Follow the instructions given when installing items sold separately and replacing the fuse.**
This may result in fire, electric shock and equipment failure.

 **Do not use the device when the alarm goes off.**
For safety reasons, please pull the power plug of the DC power equipment connected to the product out of the AC socket.

 Never touch the antenna as well. This may result in fire, electric shock and equipment failure due to thunder.

CAUTION

 **Do not place this device near a heating instrument or in a location exposed to direct sunlight.**
This may result in deformation and discoloration.

 **Do not place this device in a location where there is a lot of dust and humidity.**
Doing so may result in fire and equipment failure.

 **Stay as far away from the antenna as possible during transmission.**
Long-term exposure to electromagnetic radiation may have a negative effect on the human body.

 **Do not wipe the case using thinner and benzene etc.**
Please use a soft and dry piece of cloth to wipe away the stains on the case.

 **Keep out of the reach of small children.**
If not, this may result in injuries to children.

 **Do not put heavy objects on top of the power cord and connection cables.**
This may damage the power cord and connection cables, resulting in fire and electric shock.

 **Do not transmit near the television and radio.**
This may result in electromagnetic interference.

 **Do not use optional products other than those specified by our company.**
If not, this may result in equipment failure.

 **When using the device in a hybrid car or fuel-saving car, make sure to check with the car manufacturer before using.**
The device may not be able to receive transmissions normally due to the influence of noises from the electrical devices (inverters etc.) fitted in the car.

 **For safety reasons, switch off the power and pull out the DC power cord connected to the DC power connector when the device is not going to be used for a long period of time.**
If not, this may result in fire and overheating.

 **Do not throw or subject the device to strong impact forces.**
This may result in equipment failure.

 **Do not put this device near magnetic cards and video tapes.**
The data in the cash card and video tape etc. may be erased.

 **Do not turn on the volume too high when using a headphone or earphone.**
This may result in hearing impairment.

 **Do not place the device on an unsteady or sloping surface, or in a location where there is a lot of vibration.**
The device may fall over or drop, resulting in fire, injury and equipment failure.

 **Do not stand on top of the product, and do not place heavy objects on top or insert objects inside it.**
If not, this may result in equipment failure.

 **Do not use a microphone other than those specified when connecting a microphone to the device.**
If not, this may result in equipment failure.

 **Do not touch the heat radiating parts.**
When used for a long period of time, the temperature of the heat radiating parts will get higher, resulting in burns when touched.

 **Do not open the case of the product except when replacing the fuse and when installing items sold separately.**
This may result in injury, electric shock and equipment failure.

About the antenna

The antenna is an extremely important part for both transmitting and receiving. The antenna type and its inherent characteristics determine whether the performance of the transceiver can be fully realized. As such, please note the following:

- Use an antenna that is suitable for the installation conditions and application objective.
- Use an antenna that is suitable for the operating frequency band.
- Use an antenna and a coaxial cable with a characteristic feed point impedance of 50Ω .
- Adjust the VSWR (Voltage Standing Wave Ratio) until it is 1.5 or less for an antenna with an adjusted impedance of 50Ω .
- Keep the coaxial cable routing length as short as possible.

Connection of Antenna and Power Cables

Please follow the outline in the illustration regarding the proper connection of antenna coaxial cables and Power Supply.

Cautions

- Do not use a DC power supply cable other than the one that is provided.
- Do not use the DC power supply cable with the fuse holder cut off.
- Use an external power source capable of supplying DC 13.8 V, a current capacity of 15 A or more.

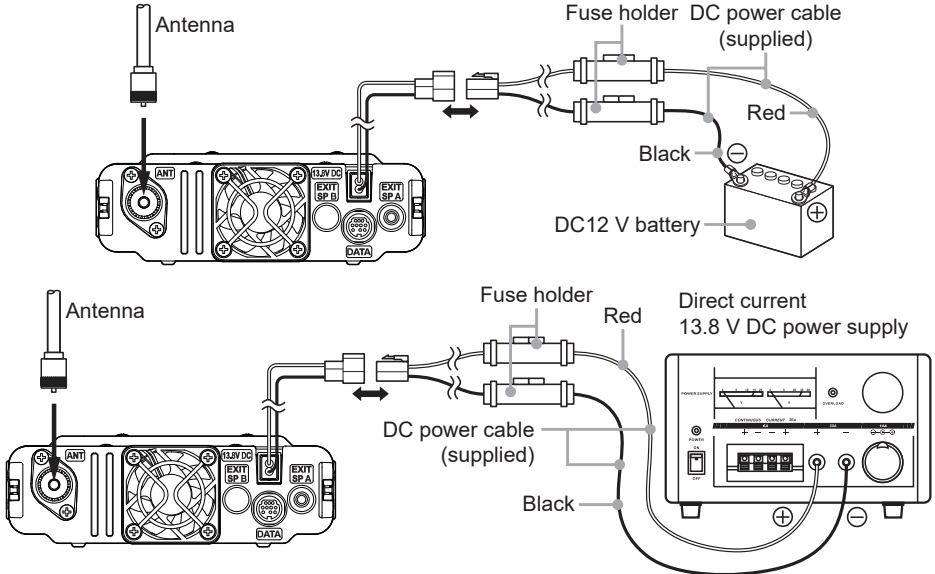

Installing the transceiver

Install the main body and the front panel using the supplied brackets.



- The bracket can be formed by hand to match the location where the front panel is installed.
- Be careful not to cause an injury when bending the bracket.

1. Select the installation location.

Caution : Select a location where the transceiver can be securely attached.

2. Drill four 6mm diameter holes in the location where the bracket is to be mounted, matching the positions of the bolting holes of the bracket.
3. Insert the grooves on both sides of the main body into the bracket until they click and lock. Tighten the screw against the lever to lock the transceiver in the bracket.
4. To remove the main body from the bracket, loosen the locking screw, and then pull the transceiver out while pressing the lever indicated by the arrow below.

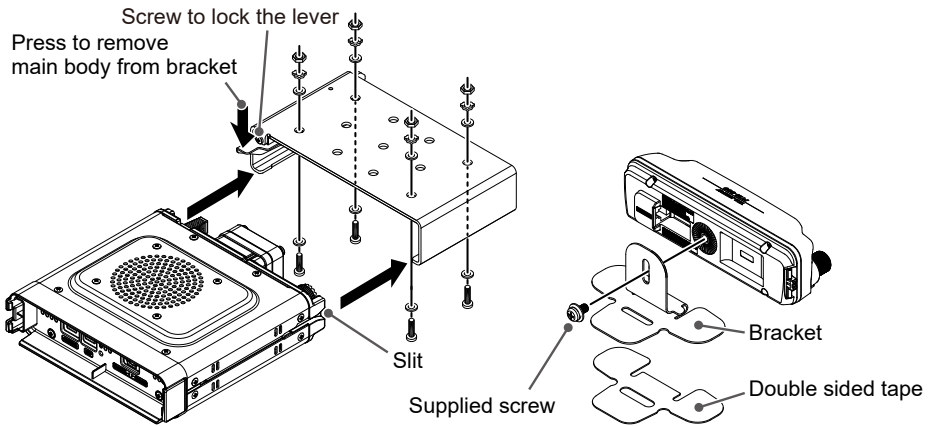

Connecting the front panel to the main body

Connect the transceiver to the “**CONTROL**” jack of the control panel with the included control cable. Connect the cable of the supplied microphone SSM-85D to the “**MIC**” terminal of the transceiver.

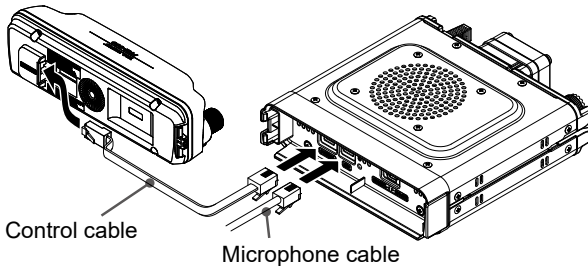

Communicating Via the Repeater

The transceiver includes an ARS (Automatic Repeater Shift) function which automatically sets the repeater operation when the receiver is tuned to the repeater frequency.

1. Set the receive frequency to the repeater frequency “-” or “+” icon appears on top of the display.
2. Speak into the microphone while pressing and holding the **PTT** switch.



● Reverse function

The “reverse” state temporarily reverses the transmit and receive frequencies. This allows checking to find if direct communication with the other station is possible.

1. Press the **[F MENU]** key.
2. Rotate the **DIAL** knob to select **[F-19 RPT.REV]**, then press the **DIAL** knob.

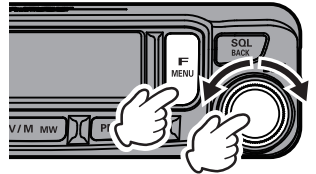

In the factory default setting, **[F-19 RPT.REV]** is registered in the “Function List” that is displayed when the **[F MENU]** key is pressed.

- The transmit and receive frequencies are temporarily reversed (“reverse” state).
- In the “reverse” state, the “-” or “+” blinks on the display.

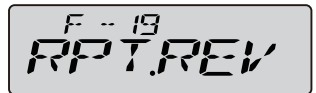

3. To release the reverse state, repeat the above steps again.

- The repeater settings may be changed from the Menu list.



- Function list [20 RPT.SET]: Allows setting the repeater shift direction.
- Menu list [21 RPT.OTR] → [RPT.ARS]: The ARS function may be set to OFF
- Menu list [21 RPT.OTR] → [RPT.FRQ]: Allows changing the repeater shift offset.
- Menu list [25 SQL.COD]: CTCSS Tone frequency

● Tone Calling (1750 Hz)

If the transceiver is FTM-6000R/E (European/Asian versions), press and hold in the **[P4]** key on the microphone (in factory default setting) to generate a 1750 Hz burst tone to access the European repeater. The transmitter will automatically be activated, and a 1750 Hz audio tone will be superimposed on the carrier. Once access to the repeater has been achieved, release the switch, and thereafter use the switch for activating the transmitter. To access repeaters which require a 1750 Hz burst tone with the FTM-6000R (USA version), set the program key on the microphone to serve as a “**T-CALL**” key. To change the configuration of this switch, use menu list **[14 MIC.PGM]**.

Using the Memory

The FTM-6000R/E incorporates a large number of memory channels that can register the operating frequency, communication mode, and other operational information.

- 999 Memory Channels
- 1 Home Channel
- 50 pairs PMS Memory Channels

The operating frequency and other operational information can be registered to each regular memory channel, home channel, or PMS memory channel:

- Operating frequency
- Frequency Step
- Transmitter output
- Memory tag
- Repeater Shift
- Tone information
- DCS information
- Memory channel skip information

NOTE

Make sure to keep a separate record of the information registered to the memory channels.

Writing to memory

1. Set the frequency to write to memory.
2. Press and hold the [V/M MW] key.
 - “**M**” icon and a memory number will appear (blinking) on the display.
 - The lowest number that is not already stored in memory is selected. To select another channel, rotate the **DIAL** knob to select the memory channel number to be written.
 - Press the **DIAL** knob to fast-forward in 10 channel steps.

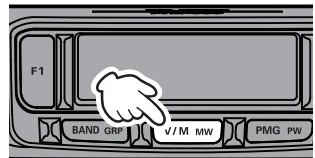

If the channel is already occupied by previously stored data, the “channel number” will light up on the display.

3. Press and hold the [V/M MW] key to save the entry and exit to normal operation.

If you attempt to register a frequency to a memory channel that already contains frequency data, “OVWRT?” will appear on the screen. Press the [V/M MW] key to overwrite the memory channel.

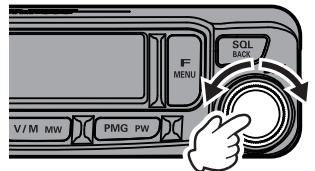

● Split Memory

Two different frequencies, one for receive and another for transmit, can be registered to a memory channel.



For additional details on the Split Memory, refer to the Advanced Manual which may be downloaded from the Yaesu website.

Recall memory

1. Press the [V/M MW] key.
 - The last used memory channel is recalled.
 - “**M**” icon and a memory number will appear on the display.

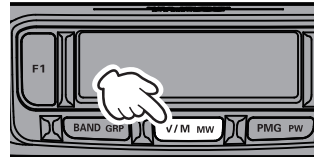

2. Rotate the **DIAL** knob to select the memory channel to recall.
3. Press the [V/M MW] key again to return to VFO mode.

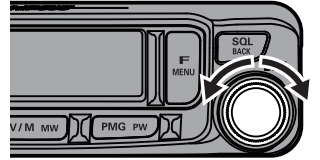

● Recall a memory by directly inputting the channel number using the numeric keys on the microphone

Press the numeric keys “0” to “9” in the memory mode to enter the memory channel.

(**Example**) When recalling memory channel “123”.

Press the [1] key.



Press the [2] key.



Press the [3] key.

(**Example**) When recalling memory channel “16”.

Press the [1] key.



Press the [6] key.



Press and hold any numeric key.

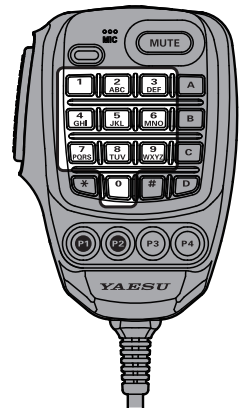





Press the **PTT** switch while entering a number to cancel the entry.

Recall only memories in the same frequency band (Band) using the memory auto grouping (MAG) function

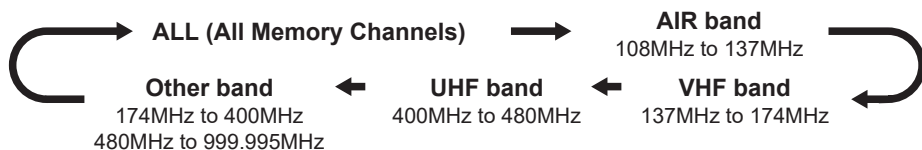
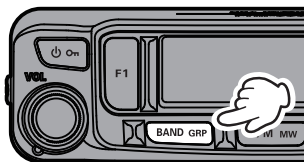
With the memory auto grouping (MAG) function, only memory channels in the same frequency band (Band) can be called.

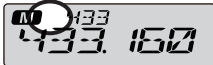
In the memory mode, each time the [BAND GRP] key is pressed, only memory channels of the specified frequency band are automatically recalled as a group, as shown below:

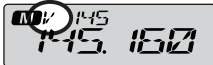
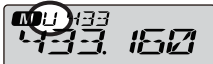

Group Name	Selectable Memory Channels
ALL No icon display 	All memory channels.
AIR "A" icon blink 	AIR band (108MHz to 137MHz) memory channels only.
VHF "V" icon blink 	VHF band (137MHz to 174MHz) memory channels only.
UHF "U" icon blink 	UHF band (400MHz to 480MHz) memory channels only.
Other "O" icon blink 	Other bands (174MHz to 400MHz & 480MHz to 999.995MHz) memory channels only.