

YAESU
The radio

HF/50 MHz TRANSCEIVER
FT DX 3000
OPERATING MANUAL



YAESU MUSEN CO., LTD.

Tennozu Parkside Building
2-5-8 Higashi-Shinagawa, Shinagawa-ku, Tokyo 140-0002 Japan

YAESU USA

6125 Phyllis Drive, Cypress, CA 90630, U.S.A.

YAESU UK LTD.

Unit 12, Sun Valley Business Park, Winnall Close
Winchester, Hampshire, SO23 0LB, U.K.

YAESU HK LTD.

Unit 1306-1308, 13F., Millennium City 2, 378 Kwun Tong Road,
Kwun Tong, Kowloon, Hong Kong

ABOUT THIS MANUAL . . .

The **FTDX3000** is a leading-edge transceiver with a number of new and exciting features, some of which may be unfamiliar to you. In order to gain the most enjoyment and operating efficiency from your **FTDX3000**, we recommend that you read this manual in its entirety, and keep it handy for reference as you explore the many capabilities of your new transceiver.

Before using your **FTDX3000**, be sure to read and follow the instructions in the “Before You Begin” section of this manual.

GENERAL DESCRIPTION

Congratulations on the purchase of your Yaesu amateur transceiver! Whether this is your first rig, or if Yaesu equipment is already the backbone of your station, rest assured your transceiver will provide many hours of operating pleasure for years to come.

The **FT DX 3000** is an elite-class HF transceiver providing exceptional performance both on transmit and receive. The **FT DX 3000** is designed for the most competitive operating situations, whether you primarily operate in contest, DX, or digital-mode environments.

Built on the foundation of the popular **FT DX 3000** transceiver, and carrying the proud tradition of the **FT-1000** series, the **FT DX 3000** provides up to 100 Watts of power output on SSB, CW, and FM (25 Watts AM carrier). Digital Signal Processing (DSP) is utilized throughout the design, providing leading-edge performance, both transmit and receive.

For exceptional protection from strong signal interference, the optional RF μ Tuning Kits may be connected via the rear panel. The μ Tuning Kits provide extraordinarily sharp selectivity, and protect your receiver from close-in interference on a crowded band.

In the front end, you may select one of two RF preamplifiers, or IPO (Intercept Point Optimization) providing direct feed to the first mixer. Three levels of RF attenuation are available in 6-dB steps.

The **FT DX 3000** receiver utilizes DSP filtering, incorporating many of the features of the **FT DX 9000**, such as, Variable Bandwidth, IF Shift, and Passband Contour tuning. Also provided are Digital Noise Reduction, Digital Auto-Notch Filtering and a manually tuned IF Notch filter.

On the transmit side, the Yaesu-exclusive Three-Band Parametric Microphone Equalizer allows precise and flexible adjustment of the waveform created by your voice and microphone. The Amplitude, Center Frequency, and Bandwidth are adjusted separately for the low, mid-range, and high-frequency audio spectra. The transmitted bandwidth may also be adjusted.

Advanced features include: Direct Keyboard Frequency Entry and Band Change, Speech Processor, IF Monitor for Voice modes, CW Pitch control, CW Spot switch, Full CW QSK, adjustable IF Noise Blanker, and all-mode Squelch. Three TX/RX antenna ports are provided on the rear panel. Two key jacks are provided (one on the front and one on the rear panel). The key jacks may be configured independently for paddle input, connection to a straight key, or computer-driven keying interface. The CW Message Memory is provided.

Frequency setup is straightforward on the **FT DX 3000**. Enter frequency directly for both VFO-A and VFO-B. Separate keys are provided for band selection. Each band key provides three separate VFO settings for three different parts of each band. You can establish three independent VFO settings of frequency, mode, and filter for each band.

In addition, 99 memories are provided to store: Frequency, Mode, IF filter selection, Clarifier offset, and Scan-skip status. What's more, five quick-recall ("QMB") memories can instantly store operational settings at the push of a button.

The built-in antenna tuner includes 100 memories that automatically store antenna matching settings for rapid automatic recall later.

Interfacing for digital modes is extremely simple with the **FT DX 3000**, thanks to the dedicated RTTY/PKT connection jack on the rear panel. Optimization of the filter passband, DSP settings, carrier insertion point, and display offset for digital modes, is possible via the Menu programming system.

Advanced technology is only part of the **FT DX 3000** story. Yaesu stands behind our products with a worldwide network of dealers and service centers. We greatly appreciate your investment in the **FT DX 3000**, and we look forward to helping you get the most out of your new transceiver. Please feel free to contact your nearest dealer, or one of Yaesu's national headquarters offices, for technical advice, interfacing assistance, or accessory recommendation. Watch Yaesu U.S.A.'s Home Page for late-breaking information about Standard Horizon and Yaesu products: <http://www.yaesu.com>.

Please read this manual thoroughly, to gain maximum understanding of the full capability of the **FT DX 3000**. We thank you again for your purchase!

TABLE OF CONTENTS

General Description	1	Interference Rejection	42
Accessories & Options	4	Receiver Operation (Front End Block Diagram) ...	42
Supplied Accessories	4	ATT	43
Available Options	5	μ-Tune Filter	44
Before You Begin	6	IPO (Intercept Point Optimization)	46
Extending the Front Feet	6	R.FLT (Roofing Filters)	47
Adjusting the Main Tuning Dial Torque	6	IF Noise Blanker (NB) Operation	48
Resetting the Microprocessor	7	CONTOUR Control Operation	49
Resetting Memories (Only)	7	IF SHIFT Operation	50
Menu Resetting	7	WIDTH (IF DSP Bandwidth) Tuning	51
Full Reset	7	Using IF Shift and Width Together	51
Installation and Interconnections	8	NARROW (NAR) One-Touch IF Filter Selection	52
Antenna Considerations	8	IF Notch Filter Operation	53
About Coaxial Cable	8	Digital Notch Filter (DNF) Operation	54
Grounding	9	Digital Noise Reduction (DNR) Operation	54
Connection of Antenna and Power Cables	10	RF Gain (SSB/CW/AM Modes)	55
Connection of Microphone and Headphone	11	Tools for Comfortable and Effective Reception	56
Key, Keyer, and Computer-Driven Keying		Audio Pitch Control	56
Interconnections	12	Mute Feature	56
VL-1000 Linear Amplifier Interconnections	13	AGC (Automatic Gain Control)	57
Interfacing to Other Linear Amplifiers	14	SSB/AM Mode Transmission	58
Plug/Connector Pinout Diagrams	15	Using the Automatic Antenna Tuner	60
Front Panel Controls & Switches	16	ATU Operation	60
Display Indications	26	About ATU Operation	61
Rear Panel	29	Enhancing Transmit Signal Quality	62
Basic Operation: Receiving on Amateur Bands	31	Parametric Microphone Equalizer	62
Operation on 60-Meter (5 MHz) Band		Using the Speech Processor	64
(U.S. and U.K. version only)	34	Adjusting the SSB Transmitted Bandwidth	65
CLAR (Clarifier) Operation	35	Transmitter Convenience Features	66
LOCK	36	Voice Memory	66
DIMMER	36	Voice Memory Operation from	
Convenience Features	37	the optional FH-2 Remote Control Keypad	66
Using VFO-B	37	VOX (Automatic TX/RX Switching using Voice Control)	68
Band Stack Operation	39	MONITOR	69
C.S (Custom Switch)	39	Split Operation Using the TX Clarifier	70
Rotator Control Functions	40	Split-Frequency Operation	71
More Frequency Navigation Techniques	41	Quick Split Operation	71
Keyboard Frequency Entry	41		
Using the [CLAR/VFO-B] knob	41		
Using the UP/DOWN switches of			
the supplied MH-31B8 Hand Microphone	41		

TABLE OF CONTENTS

CW Mode Operation	72	Operation on Alaska Emergency Frequency: 5167.5 kHz (U.S. Version Only)	94
Setup for Straight Key (and Straight Key emulation) Operation	72	VFO and Memory Scanning	95
Using the Built-in Electronic Keyer	73	VFO Scanning	95
Full Break-in (QSK) Operation	74	Memory Scan	96
Setting the Keyer Weight (Dot/Dash) Ratio	74	PMS (Programmable Memory Scan)	97
Selecting the Keyer Operating Mode	75	Packet Operation	98
CW Convenience Features	78	Packet Setup (Including Subcarrier Frequency)	98
Audio Peak Filter	76	Basic Setup	98
CW Spotting (Zero-Beating)	77	RTTY (Radio Teletype) Operation	99
Using CW Reverse	78	Setting Up for RTTY Operation	99
CW Delay Time Setting	79	Basic Setup	99
CW Pitch Adjustment	79	Miscellaneous AFSK-Based Data Modes	100
Contest Memory Keyer (Using the optional FH-2 Remote Control Keypad)	80	Menu Mode	102
Message Memory	80	Using the Menu	102
TEXT Memory	82	Menu Mode Reset	102
FM Mode Operation	85	Specifications	108
Basic Operation	85	FCC Notice	110
Repeater Operation	86		
Tone Squelch Operation	87		
Memory Operation	88		
Convenient Memory functions	88		
QMB (Quick Memory Bank)	89		
Standard Memory Operation	90		
Memory Storage	90		
Memory Channel Recall	90		
Checking Memory Channel Status	91		
Erasing Memory Channel Data	91		
Moving Memory Data to the Main Band (VFO-A)	92		
Memory Tune Operation	92		
Memory Groups	93		
Memory Group Assignment	93		
Choosing the Desired Memory Group	93		

ACCESSORIES & OPTIONS

SUPPLIED ACCESSORIES

Hand Microphone (MH-31B8)	1 pc	A07890001
FH-2		Remote Control Keypad
DC Power Cord	1 pc	T9025225
Spare Fuse (25A)	1 pc	Q0000074
Operating Manual	1 pc	
Warranty Card	1 pc	

ACCESSORIES & OPTIONS

AVAILABLE OPTIONS

MD-200A8X	Ultra-High-Fidelity Desktop Microphone
MD-100A8X	Desktop Microphone
YH-77STA	Lightweight Stereo Headphone
VL-1000/VP-1000	Linear Amplifier/AC Power Supply
RF μTuning Kit A	For 160 m Band
RF μTuning Kit B	For 80/40 m Bands
RF μTuning Kit C	For 30/20 m Bands
FC-40	External Automatic Antenna Tuner
DVS-6	Voice Memory Unit
FH-2	Remote Control Keypad
CT-118	VL-1000 Linear Amplifire Connection Cable
CT Cable (MDIN6P - MDIN6P 2m)	Antenna Rotator Connection Cable (P/N T9101556)
CT Cable (MDIN10P - Bare Wire 2m)	Linear Amplifier Connection Cable (P/N T9207451)

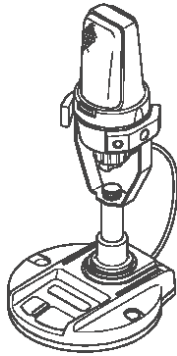

MD-200A8X



YH-77STA

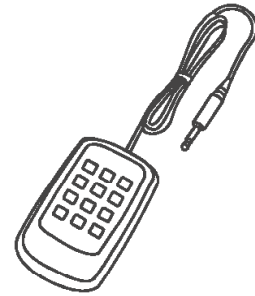

FH-2

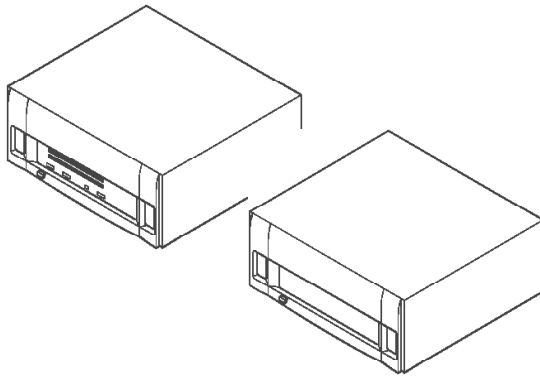

VL-1000/VP-1000

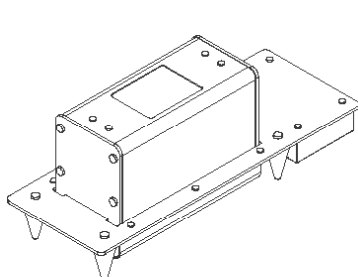

RF μ Tuning Kit

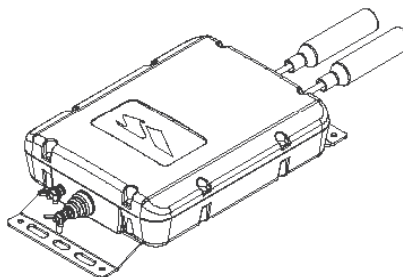

FC-40

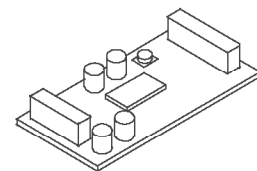

DVS-6

BEFORE YOU BEGIN

EXTENDING THE FRONT FEET

To elevate the front panel for easy viewing, the front left and right feet of the bottom case may be extended.

- Pull the front legs outward from the bottom panel.
- Rotate the legs counter-clockwise to lock them in the extended position. Be sure the legs have locked securely in place, because the transceiver is quite heavy and an unlocked leg could result in damage, should the transceiver move suddenly.

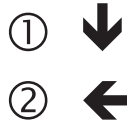
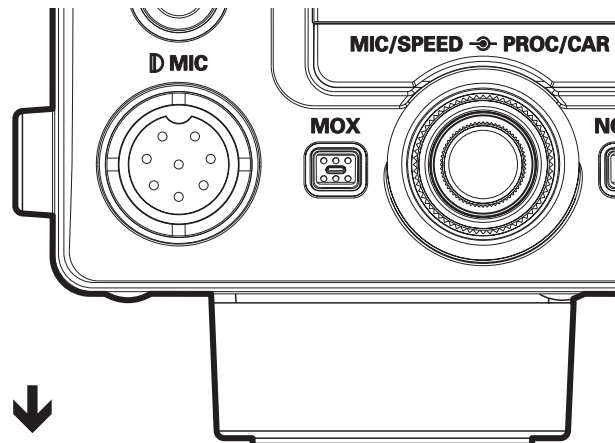

Retracting the Front Feet

- Rotate the legs clockwise, and push them inward while rotating to the right.
- The front feet should now be locked in the retracted position.

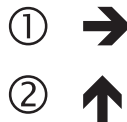
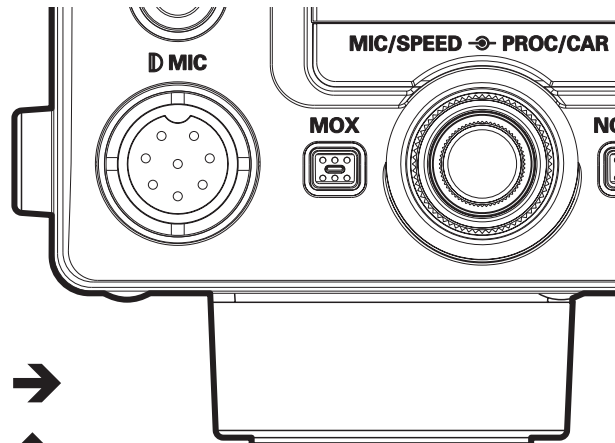

ADJUSTING THE MAIN TUNING DIAL TORQUE

The torque (drag) of the Main Tuning Dial knob may be adjusted according to your preferences. Simply hold down the rear skirt of the knob, and while holding it in place rotate the knob clockwise to reduce the drag or counter-clockwise to increase the drag.

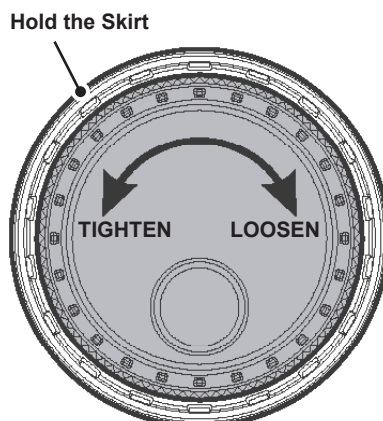

BEFORE YOU BEGIN

RESETTING THE MICROPROCESSOR

RESETTING MEMORIES (ONLY)

Use this procedure to reset (clear) the previously stored Memory channels, without affecting any configuration changes you may have made to the Menu settings.

1. Press the front panel's **[POWER]** switch to turn the transceiver off.
2. Press and hold in the **[A▶M]** button; while holding it in, press and hold in the front panel's **[POWER]** switch to turn the transceiver on. Once the transceiver comes on, you may release the buttons.

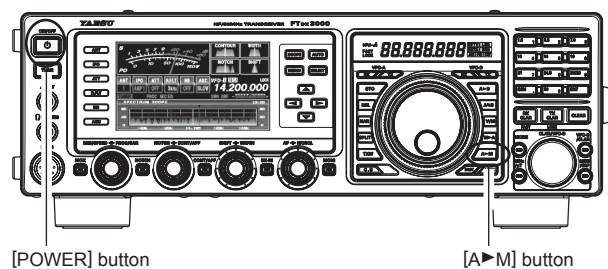

MENU RESETTING

Use this procedure to restore the Menu settings to their factory defaults, without affecting the memories you have programmed.

1. Press the front panel **[POWER]** switch to turn the transceiver off.
2. Press and hold in the **[MENU]** button; while holding it in, press and hold in the front panel **[POWER]** switch to turn the transceiver on. Once the transceiver comes on, you may release the buttons.

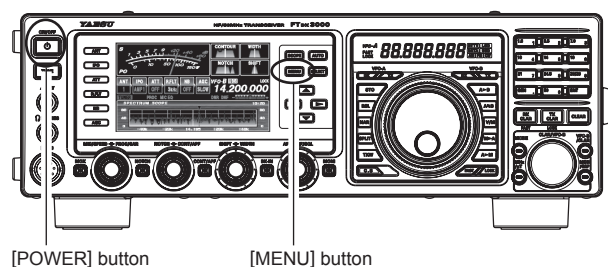

FULL RESET

Use this procedure to restore all Menu and Memory settings to their original factory defaults. All Memories will be cleared by this procedure.

1. Press the front panel **[POWER]** switch to turn the transceiver off.
2. Press and hold the **[FAST]** and **[LOCK]** buttons; while holding them in, press and hold in the front panel **[POWER]** switch to turn the transceiver on. Once the transceiver comes on, you may release the buttons.

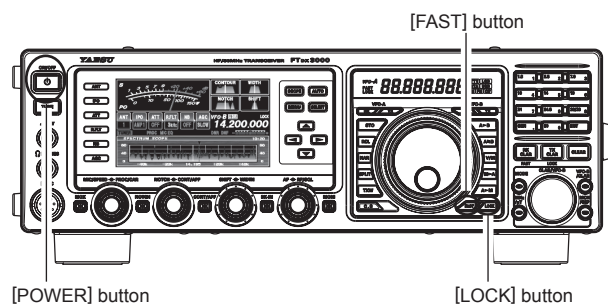

IMPORTANT NOTE:

When the optional μ Tuning Kit is connected to the **FT DX 3000**, disconnect all the cables from the μ Tuning Kit before performing the Full Reset.

INSTALLATION AND INTERCONNECTIONS

ANTENNA CONSIDERATIONS

The **FT dx 3000** is designed for use with any antenna system providing a 50 Ohm resistive impedance at the desired operating frequency. While minor excursions from the 50-Ohm specification are of no consequence, if the Standing Wave Ratio (SWR) present at the Antenna jack is greater than 3:1, the transceiver's Automatic Antenna Tuner may not be able to reduce the impedance mismatch to an acceptable value.

Every effort should be made to ensure that the impedance of the antenna system be as close as possible to the specified 50-Ohm value. Note that the "G5RV" type antenna does not provide a 50-Ohm impedance on all HF Amateur bands. An external wide-range antenna coupler must be used with this antenna type.

Any antenna to be used with the **FT dx 3000** must be fed from the transceiver with 50 Ohm coaxial cable. Therefore, when using a "balanced" antenna such as a dipole, remember that a balun or other matching/balancing device must be used to ensure proper antenna performance.

The same precautions apply to any additional (receive-only) antennas connected to the antenna jacks; if your receive-only antennas do not have impedance near 50 Ohms at the operating frequency, you may need to install an external antenna tuner to obtain optimum performance.

ABOUT COAXIAL CABLE

Use high-quality 50-Ohm coaxial cable for the lead-in to your **FT DX 3000** transceiver. All efforts at providing an efficient antenna system will be wasted if poor quality, lossy coaxial cable is used. This transceiver utilizes standard "M" ("PL-259") type connectors.

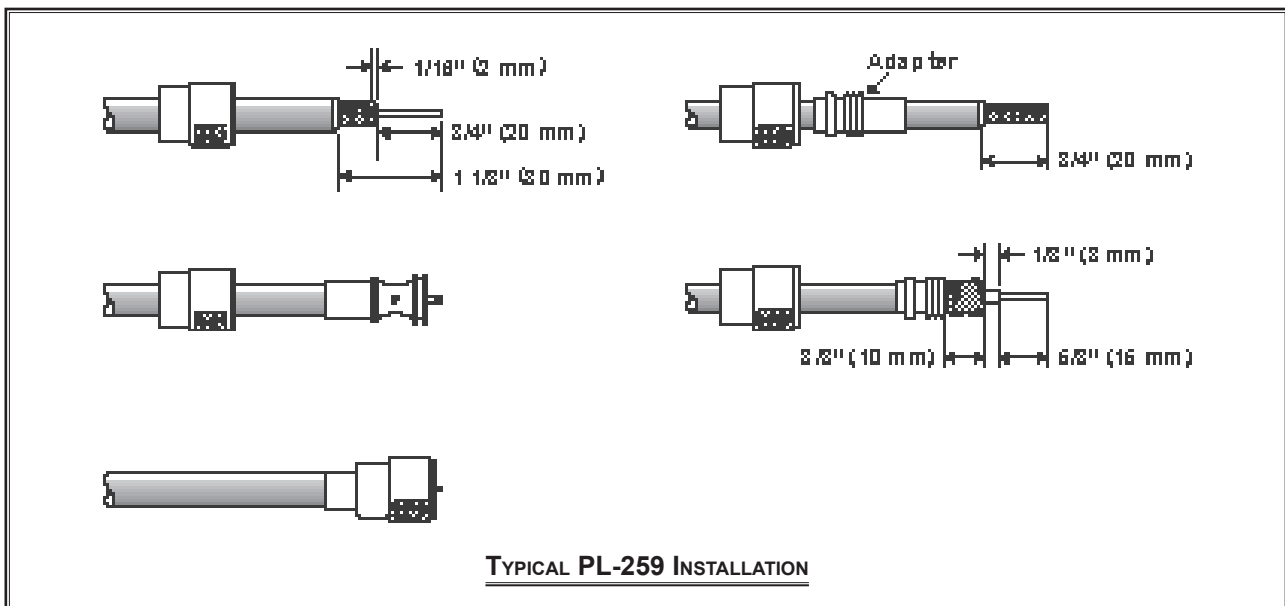

INSTALLATION AND INTERCONNECTIONS

GROUNDING

The **FT DX 3000** transceiver, like any other HF communications apparatus, requires an effective ground system for maximum electrical safety and best communications effectiveness. A good ground system can contribute to station efficiency in a number of ways:

- ❑ It can minimize the possibility of electrical shock to the operator.
- ❑ It can minimize RF currents flowing on the shield of the coaxial cable and the chassis of the transceiver; such currents may lead to radiation, which can cause interference to home entertainment devices or laboratory test equipment.
- ❑ It can minimize the possibility of erratic transceiver/accessory operation caused by RF feedback and/or improper current flow through logic devices.

An effective earth ground system may take several forms; for a more complete discussion, see an appropriate RF engineering text. The information below is intended only as a guideline.

Typically, the ground connection consists of one or more copper-clad steel rods, driven into the ground. If multiple ground rods are used, they should be positioned in a “V” configuration, and bonded together at the base of the “V” which is nearest the station location. Use a heavy, braided cable (such as the discarded shield from type RG-213 coaxial cable), and strong cable clamps to secure the braided cable(s) to the ground rods. Be sure to weatherproof the connections to ensure many years of reliable service. Use the same type of heavy, braided cable for the connections to the station ground bus (described below).

Inside the station, a common ground bus consisting of a copper pipe of at least 25 mm diameter should be used. An alternative station ground bus may consist of a wide copper plate (single-sided circuit board material is ideal) secured to the bottom of the operating desk. Grounding connections from individual transceivers, power supplies, and data communications devices (TNCs, etc.) should be made directly to the ground bus using a heavy, braided cable.

Do not “Daisy-Chain” ground connections from one electrical device to another, and thence to the ground bus. This method may nullify any attempt at effective radio frequency grounding. See the drawing below for examples of proper grounding techniques.

Inspect the ground system - inside the station as well as outside - on a regular basis to ensure continued performance and safety.

Besides following the above guidelines carefully, note that household or industrial gas lines must never be used in an attempt to establish an electrical ground. Cold water pipes may, in some instances, help in the grounding effort, but gas lines represent a significant explosion hazard, and must never be used.

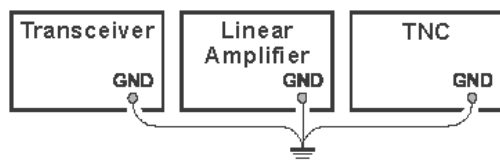

PROPER GROUND CONNECTION

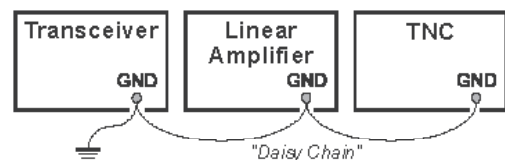

IMPROPER GROUND CONNECTION

INSTALLATION AND INTERCONNECTIONS

CONNECTION OF ANTENNA AND POWER CABLES

Please follow the outline in the illustration regarding the proper connection of antenna coaxial cables, as well as the DC power cable. The DC power connector for the **FT dx 3000** must only be connected to a DC source providing 13.8 Volts DC ($\pm 10\%$), and capable of at least 23 Amperes of current. Always observe proper polarity when making DC connection:

The RED DC power lead connects to the Positive (+) DC terminal.

The BLACK DC power lead connects to the Negative (-) DC terminal.

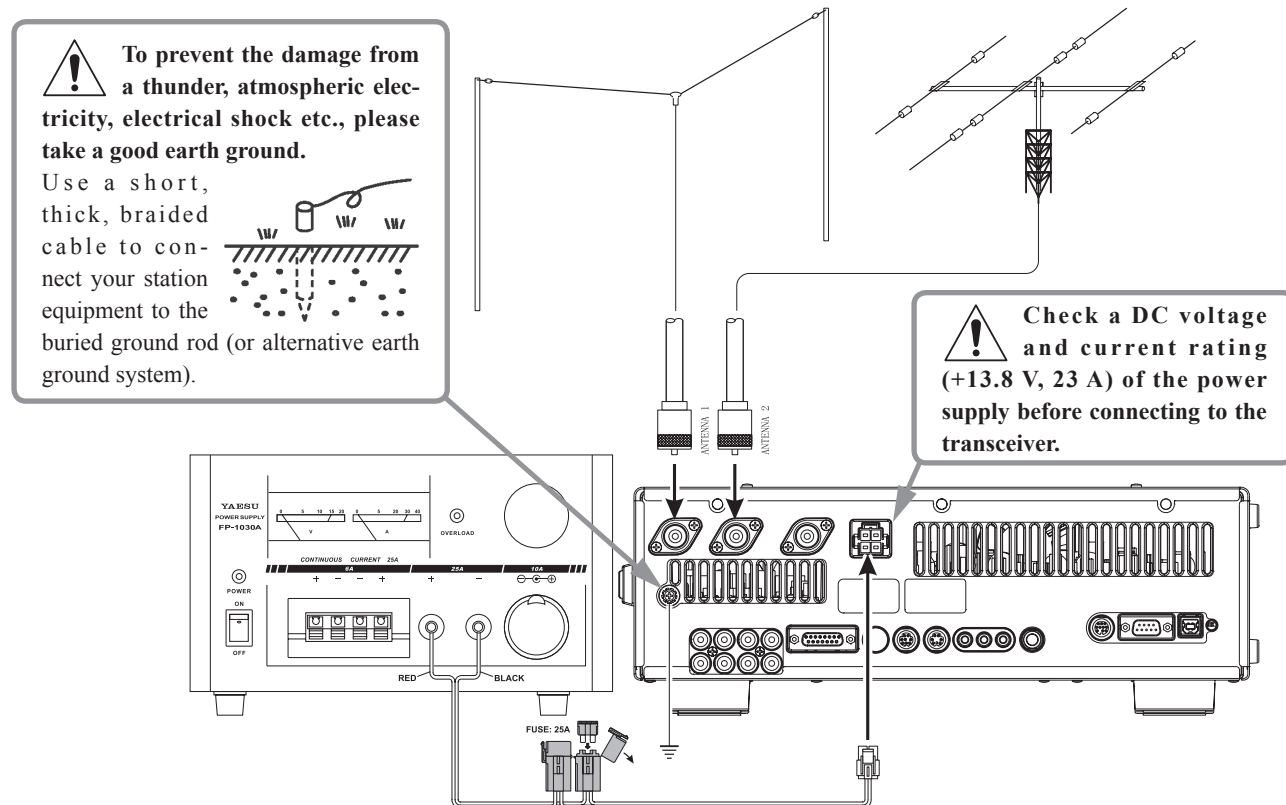

We recommend the use of the **FP-1030A** AC Power Supply. Other models of power supplies may be used with the **FT dx 3000**, but the 13.8 VDC input voltage, 23 Ampere current capability, and DC cable polarity guidelines described above must be strictly followed.

Note that other manufacturers may use the same type of DC power connections as does your **FT dx 3000** transceiver, however, the wiring configuration may be different from that specified for your transceiver. Serious damage can be caused if improper DC connections are made; consult with a qualified service technician when in doubt.

! Permanent damage can result when improper supply voltage, or reverse-polarity voltage, is applied to the FT dx 3000. The Limited Warranty on this transceiver does not cover damage caused by application of AC voltage, reverse polarity DC, or DC voltage outside the specified range of 13.8 V $\pm 10\%$. When replacing fuses, be certain to use a fuse of the proper rating. The **FT dx 3000** requires a 25 A blade fuse.

ADVICE:

- Do not position the **FT dx 3000** in a location with direct exposure to sunshine.
- Do not position the **FT dx 3000** in a location exposed to dust and/or high humidity.
- Ensure adequate ventilation around the **FT dx 3000**, to prevent heat build-up and possible reduction of performance due to high heat.
- Do not install the **FT dx 3000** on an unstable desk or table. Do not place in a location where objects may fall onto it from above.
- To minimize the possibility of interference to home entertainment devices, take all precautionary steps including separation of TV/FM antennas from Amateur transmitting antennas to the greatest extent possible, and keep transmitting coaxial cables separated from cables connected to home entertainment devices.
- Ensure that the DC power cord is not subject to undue stress or bending, which could damage the cable or cause it to be accidentally unplugged from the rear panel **DC IN** jack.
- Be certain to install your transmitting antenna(s) so they cannot possibly come in contact with TV/FM radio or other antennas, or with power or telephone lines.

INSTALLATION AND INTERCONNECTIONS

CONNECTION OF MICROPHONE AND HEADPHONE

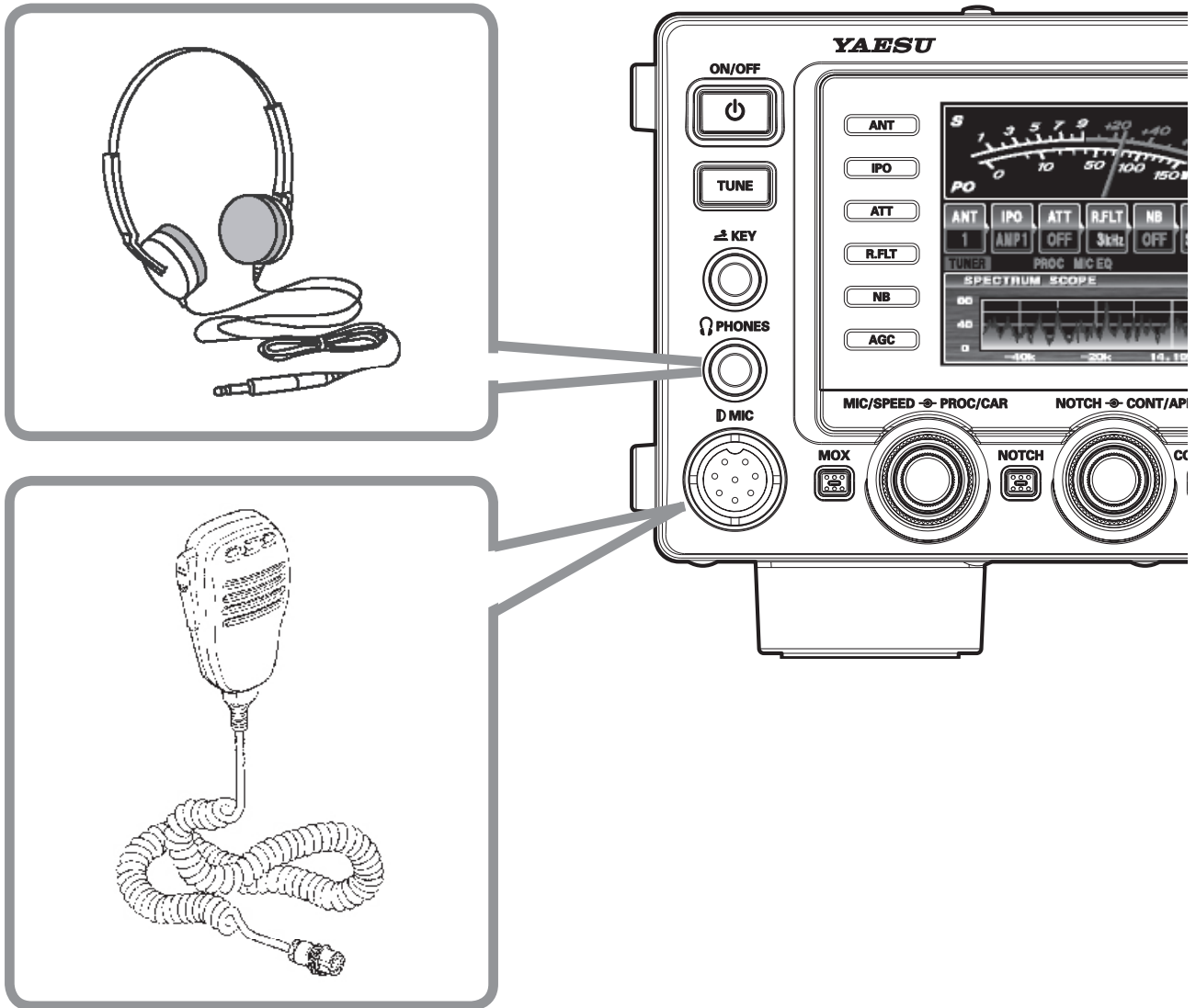

INSTALLATION AND INTERCONNECTIONS

KEY, KEYSER, AND COMPUTER-DRIVEN KEYING INTERCONNECTIONS

The **FT dx 3000** includes many features for the CW operator. These functions will be detailed in the “Operation” section later. Besides the built-in Electronic Keyer, two key jacks are provided, one on the front and one on the rear panel, for convenient connection to keying devices.

The Menu selections allow you to configure the front and rear panel **KEY** jacks according to the device you wish to connect. For example, you may connect your keyer paddle to the front panel **KEY** jack, and use Menu item “018 KEYSER F KEYSER TYPE” for paddle input, and also connect the keying line from your personal computer (which emulates a “straight key”), to the rear panel **KEY** jack, and configure the rear panel jack using Menu item “020 KEYSER R KEYSER TYPE”.

Both **KEY** jacks on the **FT dx 3000** utilize “Positive” keying voltage. Key-up voltage is approximately +3.3V DC, and key-down current is approximately 0.3 mA. When connecting a key or other device to the **KEY** jacks, use *only* a 3-contact (“stereo”) 1/4” phone plug; a 2-contact plug will place a short between the ring and (grounded) shaft of the plug, resulting in a constant “key-down” condition in some circumstances.

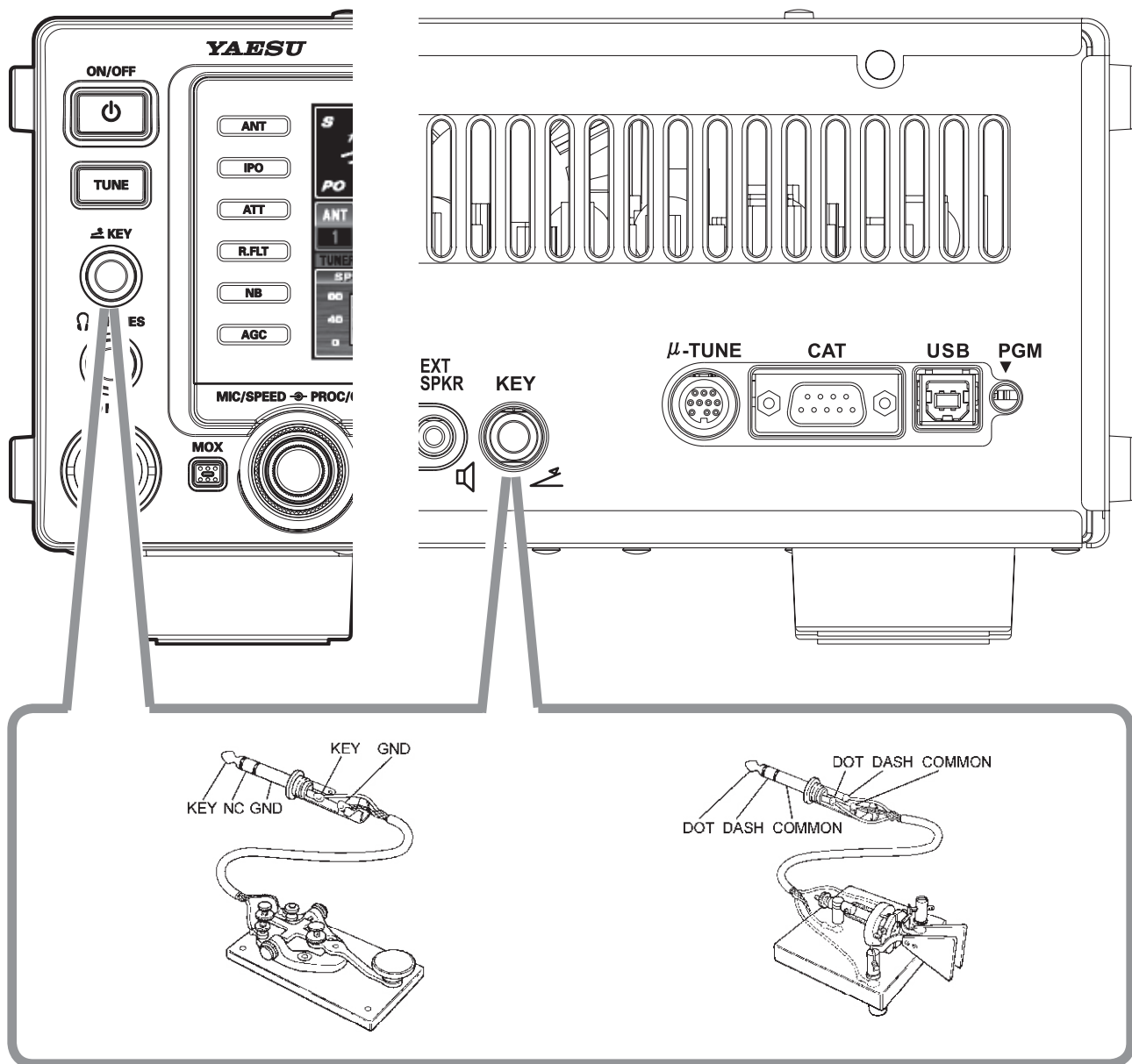

INSTALLATION AND INTERCONNECTIONS

VL-1000 LINEAR AMPLIFIER INTERCONNECTIONS

Be sure that both the **FT DX 3000** and **VL-1000** are turned off, then follow the installation recommendations contained in the illustration.

NOTE:

- Please refer to the **VL-1000** Operating Manual for details regarding amplifier operation.
- Please do not attempt to connect or disconnect coaxial cables when your hands are wet.

