

TEST REPORT

For

VHF FM TRANSCEIVER

In conformity with

FCC CFR 47 Part15 Subpart B

Model : FT-270R

FCC ID : K6620223X20

Test Item : VHF FM TRANSCEIVER

Report No. : ERY1306P26R1

Issue Date : 26 Jun. 2013

Prepared for

YAESU MUSEN CO., LTD.
Tennozu Parkside Building 2-5-8 Higashi-shinagawa,
Shinagawa-ku, Tokyo 140-0002 Japan

Prepared by

RF Technologies Ltd.
472, Nippa-cho, Kohoku-ku, Yokohama, 223-0057, Japan
Telephone: +81+(0)45- 534-0645
FAX: +81+(0)45- 534-0646

This report shall not be reproduced, except in full, without the written permission of RF Technologies Ltd. The test results in this report apply only to the sample tested. RF Technologies Ltd. is managed to ISO17025 and has the necessary knowledge and test facilities for testing according to the referenced standards.

Table of contents

1	General information.....	3
1.1	Product description	3
1.2	Test(s) performed/ Summary of test result	3
1.3	Test facility	4
1.4	Measurement uncertainty.....	4
1.5	Summary of test results.....	5
1.6	Setup of equipment under test (EUT)	5
1.6.1	Test configuration of EUT	5
1.6.2	Operating condition:	5
1.6.3	Setup diagram of tested system.....	6
1.7	Equipment modifications	6
1.8	Deviation from the standard	6
2	Test procedure and test data	7
2.1	Radiated emissions	7
2.2	AC power line conducted emissions.....	9
3	Test setup photographs	11
3.1	Radiated emissions	11
3.2	AC power line conducted emissions.....	11
4	List of utilized test equipment / calibration	12

History

Report No.	Date	Revisions	Issued By
ERY1306P26R1	26 Jun. 2013	Initial Issue	T.Kato

1 General information

1.1 Product description

Test item : VHF FM TRANSCEIVER
Manufacturer : YAESU MUSEN CO., LTD.
Address : 43 Utsuroda, Morijuku, Sukagawa-shi, Fukushima-ken 962-0001 Japan
Model : FT-270R
FCC ID : K6620223X20
Serial number : 2I991316
Software version : N/A
Hardware version : N/A
Highest operating frequency : 20 MHz
Receipt date of EUT : 19 Jun. 2013
Nominal power source voltages : 7.2 Vdc (Ni-MH Battery)

1.2 Test(s) performed/ Summary of test result

Test specification(s) : FCC CFR 47. Part 15 subpart B (01 Oct. 2010)
Test method(s) : ANSI C63.4: 2003
Test(s) started : 24 Jun. 2013
Test(s) completed : 26 Jun. 2013
Purpose of test(s) : Certification (Refer to Sec. 1.6.3)

Summary of test result : Complied

Note: The above judgment is only based on the measurement data and it does not include the measurement uncertainty. Accordingly, the statement below is applied to the test result.

The EUT complies with the limit required in the standard in case that the margin is not less than the measurement uncertainty in the Laboratory.

Compliance of the EUT is more probable than non-compliance is case that the margin is less than the measurement uncertainty in the Laboratory.

Test engineer

: 

T. Kato
EMC testing Department

Reviewer

: 

K. Ohnishi
Manager
EMC testing Department

1.3 Test facility

The Federal Communications Commission has reviewed the technical characteristics of the test facilities at RF Technologies Ltd., located in 472, Nippa-cho, Kohoku-ku, Yokohama, 223-0057, Japan, and has found these test facilities to be in compliance with the requirements of 47 CFR Part 15, section 2.948, per October 1, 2010.

The description of the test facilities has been filed under registration number 319924 at the Office of the Federal Communications Commission. The facility has been added to the list of laboratories performing these test services for the public on a fee basis.

The list of all public test facilities is available on the Internet at <http://www.fcc.gov>.

Registered by Industry Canada (IC): The registered facility number is as follows;
Test site No. 1 (Semi-Anechoic chamber 3m): 6974A-1

Accredited by **National Voluntary Laboratory Accreditation Program (NVLAP)** for the emission tests stated in the scope of the certificate under Certificate Number 200780-0

This report must not be used by the client to claim product certification, approval, or endorsement by NVLAP, NIST, or any agency of the Federal Government.



NVLAP LAB CODE 200780-0

1.4 Measurement uncertainty

The treatment of uncertainty is based on the general matters on the definition of uncertainty in “Guide to the expression of uncertainty in measurement (GUM)” published by ISO. The Lab’s uncertainty is determined by referring UKAS Publication LAB34: 2002 “The Expression of Uncertainty in EMC Testing” and CISPR16-4-2: 2011 “Uncertainty in EMC Measurements”.

The uncertainty of the measurement result in the level of confidence of approximately 95% ($k=2$) is as follows;

Conducted emission: ± 3.4 dB (10 kHz - 30 MHz)
Radiated emission (9 kHz - 30 MHz): ± 3.3 dB
Radiated emission (30 MHz - 200 MHz): ± 5.0 dB
Radiated emission (200 MHz - 1000 MHz): ± 6.2 dB

1.5 Summary of test results

Requirement	Section in FCC15	Result	Section in this report
Radiated emissions (30 to 1000 MHz) *	15.109	Complied	2.1
AC power line conducted emissions	15.107	Complied	2.2

* Maximum internal operating frequency is 20 MHz.

1.6 Setup of equipment under test (EUT)

1.6.1 Test configuration of EUT

Equipment(s) under test

No.	Item	Manufacture	Model No.	Serial No.
A	VHF FM TRANSCEIVER	YAESU MUSEN CO., LTD.	FT-270R	2I991316
B	Ni-MH BATTERY PACK	VERTEX STANDARD CO., LTD.	FNB-83	L26D

Support Equipment(s)

No.	Item	Manufacture	Model No.	Serial No.	FCC ID
C	DESKTOP CHARGER	YAESU MUSEN CO., LTD.	SBH-13	3E063	-
D	AC ADAPTOR	VERTEX STANDARD CO., LTD.	PA-48B	1209	-
E	Waterproof Speaker/Microphone	VERTEX STANDARD CO., LTD.	MH-73A4B	9M019	-

Connected cable(s)

No.	Item	Identification (Manu.etc.)	Cable Shielded	Ferrite Core	Length [m]
1	DC cable (AC Adaptor)	VERTEX STANDARD CO., LTD.	No	No	1.8
2	Speaker/Microphone cable	VERTEX STANDARD CO., LTD.	No	No	1.7

1.6.2 Operating condition:

Charging mode: EUT is powered off, and the battery is charged by AC adaptor via Desktop charger.

1.6.3 Setup diagram of tested system

[Configuration A : configuration in this test report]

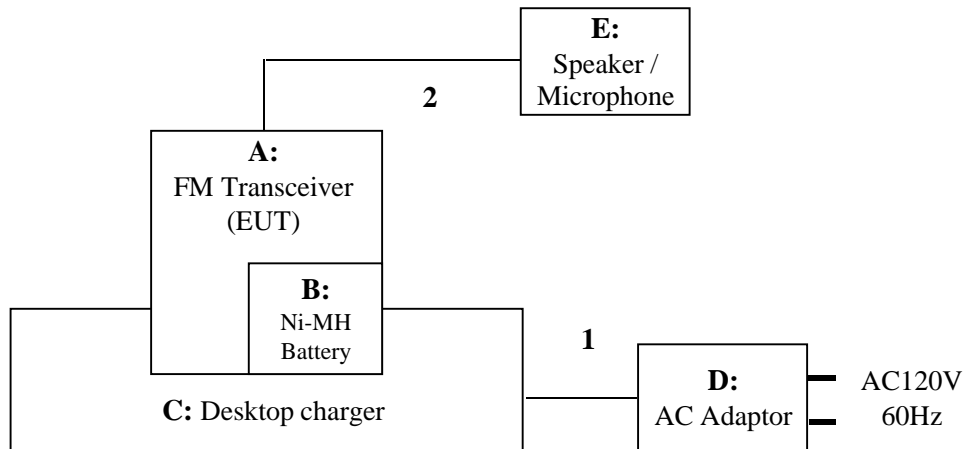

Note: This EUT was tested and certificated with below Configuration B. Then, manufacturer change the charging specification that the EUT cannot charge a battery with this configuration. After this change, the EUT can charge with above Configuration A only. For this reason, the EUT was re-tested with Configuration A in this report.

[Configuration B : configuration in the previous test]

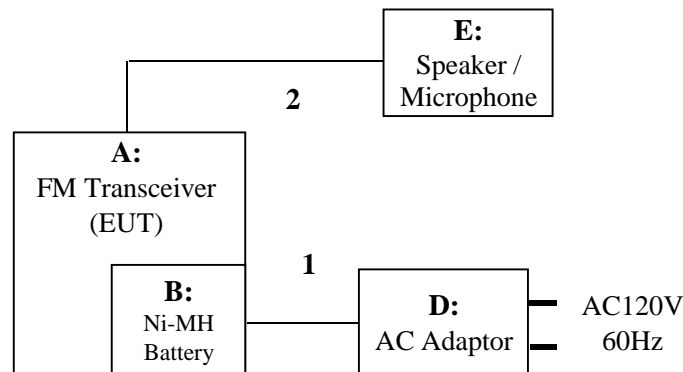

1.7 Equipment modifications

No modifications have been made to the equipment in order to achieve compliance with the applicable standards described in clause 1.2.

1.8 Deviation from the standard

No deviations from the standards described in clause 1.2.

2 Test procedure and test data

2.1 Radiated emissions

Test setup

Test setup was implemented according to the method of ANSI C63.4: 2003 clause 6 “General requirements for EUT equipment arrangements and operation”, clause 8.2 and Annex H.3 “Radiated emission measurements setup”.

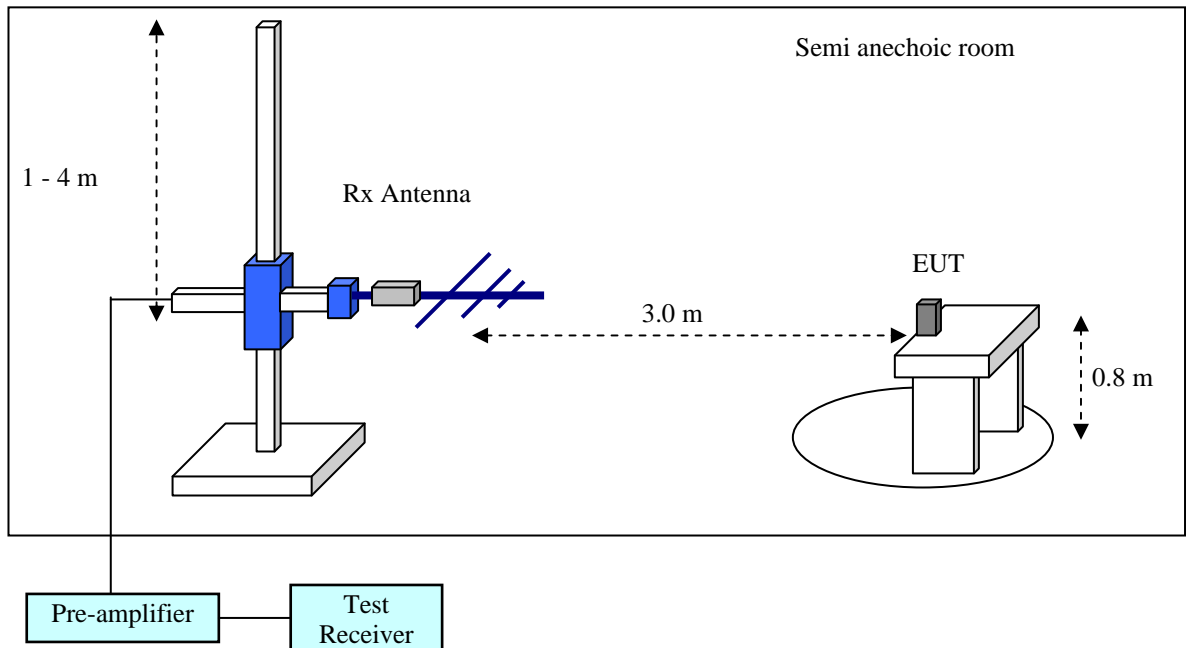

Test procedure

Measurement procedures were implemented according to the method of ANSI C63.4: 2003 clauses 8.2. The EUT is placed on a non-conducted table which is 0.8 m high from a ground plane and the measurement antenna to EUT distance is 3 meters. The turn table is rotated for 360 degrees to determine the maximum emission level.

The antenna height scanned between 1 m and 4 m, and the antenna rotated to repeat the measurements for both the horizontal and vertical antenna polarizations.

The spectrum analyzer and receiver are set to the followings;

RBW=100 kHz, VBW= 300 kHz

Final measurement is carried out with a receiver RBW of 120 kHz (QP)

Applicable rule and limitation

§15.109 (a) Radiated emission limits

Frequency [MHz]	Field Strength [$\mu\text{V/m}$]	Measurement Distance [m]	Field Strength [dB $\mu\text{V/m}$]
30 – 88	100	3	40.0
88 – 216	150	3	43.5
216 – 960	200	3	46.0
Above 960	500	3	53.9

In the emission table above, the tighter limit applies at the band edges.

The emission limits shown in the above table are based on measurements employing a quasi-peak detector.

Test results - Complied with requirement

Test equipment used (refer to List of utilized test equipment)

AC01(EM)	CL11	TR06	PR15	BI05	LA07	
----------	------	------	------	------	------	--

Test Data

Operating mode: Charging mode
Measurement distance: 3 m

[Emission level]

No.	Frequency [MHz]	Reading [dB μ V]	Factor [dB/m]	Loss [dB]	Gain [dB]	Result [dB μ V/m]	Limit [dB μ V/m]	Margin [dB]	Ant.
1	32.244	37.8	17.7	7.0	30.3	32.2	40.0	7.8	Vert.
2	40.538	41.2	14.7	7.1	30.3	32.7	40.0	7.3	Vert.
3	50.770	36.4	11.1	7.3	30.2	24.6	40.0	15.4	Vert.
4	54.373	37.4	9.9	7.3	30.2	24.4	40.0	15.6	Vert.
5	72.458	42.7	6.5	7.5	30.2	26.5	40.0	13.5	Vert.
6	99.244	38.7	10.2	7.9	30.1	26.7	43.5	16.8	Vert.
7	113.929	33.1	12.5	8.1	30.1	23.6	43.5	19.9	Vert.

[Chart]

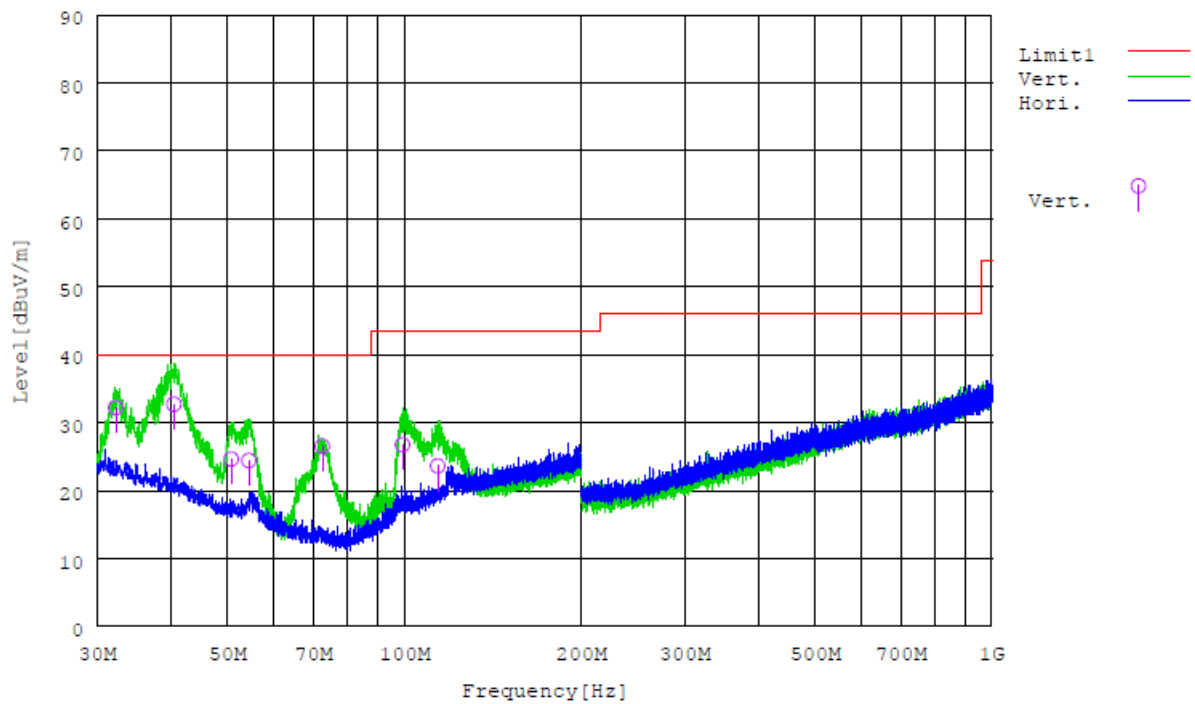

Tested Date: 24 Jun. 2013
 Humidity: 69 %

Temperature: 22 degC
 Atmos. Press: 1005 hPa

2.2 AC power line conducted emissions

Test setup

Test setup was implemented according to the method of ANSI C63.4: 2003 clause 6 “General requirements for EUT equipment arrangements and operation” and Annex H.1 “AC power line conducted emission measurements setup”.

Test procedure

Measurement procedures were implemented according to the method of ANSI C63.4: 2003 clauses 7, clause 13.1.3 and Annex H.2 “AC power line conducted emission measurements”.

Exploratory measurements were used the spectrum analyzer to identify the frequency of the emission that has the highest amplitude relative to the limit by operating the EUT in a range of typical modes of operation, cable positions, and with a typical system equipment configuration and arrangement.

Final ac power line conducted emission measurements were performed based on the exploratory tests.

The EUT cable configuration and arrangement and mode of operation that produced the emission with the highest amplitude relative to the limit are selected for the final measurement.

When the measurement value is greater than average limitation the average detection measurements were performed.

Applicable rule and limitation

§15.107 (a) AC power line conducted limits

Frequency of Emission [MHz]	Conducted Limit [dB μ V]	
	Quasi-peak	Average
0.15 - 0.5	66 to 56 *	56 to 46 *
0.5 - 5	56	46
5 - 30	60	50

* Decreases with the logarithm of the frequency. The lower limit applies at the band edges.

Test equipment used (refer to List of utilized test equipment)

TR09	LN05	CL18
------	------	------

Test results - Complied with requirement

Test Data

Operating Mode: Charging mode

[Emission level]

No.	Frequency [MHz]	Reading		C.F. [dB]	Result		Limit		Phase	Pass/Fail
		QP [dB μ V]	AV [dB μ V]		QP [dB μ V]	AV [dB μ V]	QP [dB μ V]	AV [dB μ V]		
1	0.15000	37.5	20.6	10.2	47.7	30.8	66.0	56.0	Va	Pass
2	0.15888	40.0	24.4	10.2	50.2	34.6	65.5	55.5	Va	Pass
3	0.19957	35.5	19.4	10.1	45.6	29.5	63.6	53.6	Va	Pass
4	0.36234	33.2	28.6	10.0	43.2	38.6	58.7	48.7	Va	Pass
5	0.15000	36.5	19.8	10.2	46.7	30.0	66.0	56.0	Vb	Pass
6	0.15962	39.2	23.6	10.2	49.4	33.8	65.5	55.5	Vb	Pass
7	0.19920	33.9	19.2	10.1	44.0	29.3	63.6	53.6	Vb	Pass
8	0.36382	33.7	28.2	10.0	43.7	38.2	58.6	48.6	Vb	Pass
9	25.4073	33.5	22.5	10.5	44.0	33.0	60.0	50.0	Vb	Pass

[Chart]

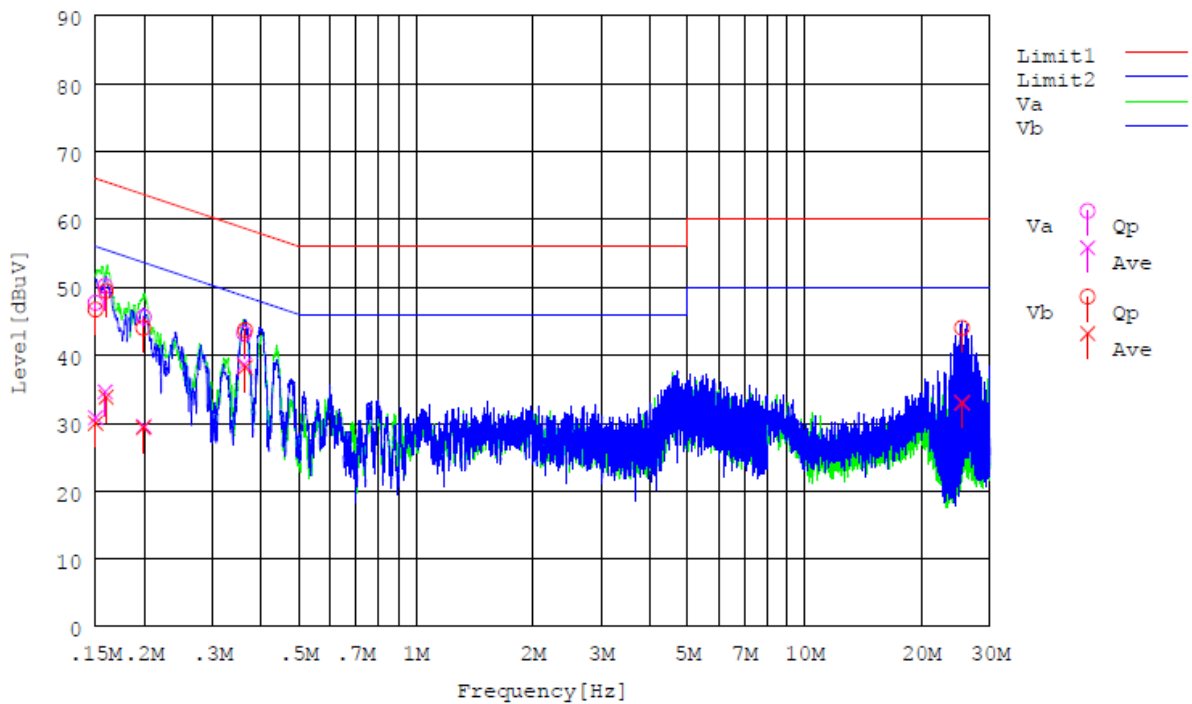

Tested Date: 26 Jun. 2013
 Humidity: 45 %

Temperature: 23 degC
 Atmos. Press: 1008 hPa

3 Test setup photographs

3.1 Radiated emissions



3.2 AC power line conducted emissions



4 List of utilized test equipment / calibration

RFT ID No.	Kind of Equipment and Precision	Manufacturer	Model No.	Serial Number	Calibration Date	Calibrated until
AC01(EM)	Anechoic Chamber (1st test room)	JSE	203397C	-	2013/4/20	2014/4/30
BI05	Biconical Antenna	SCHWARZBECK	VHA9103 & BBA9106	91032894	2012/12/3	2013/12/31
CL11	Antenna Cable for RE	RFT	-	-	2012/10/1	2013/10/31
CL18	Antenna Cable for CE	RFT	-	-	2013/5/22	2014/5/31
LA07	Logperiodic Antenna	SCHWARZBECK	VUSLP9111B	102	2012/12/3	2013/12/31
LN05	LISN	Kyoritsu	KNW-407F	8-1773-2	2013/5/20	2014/5/31
PR15	Pre. Amplifier	Anritsu	MH648A	6201156141	2013/6/11	2014/6/30
TR06	Test Receiver (F/W : 3.93 SP2)	Rohde & Schwarz	ESU26	100002	2012/9/27	2013/9/30
TR09	Test Receiver (F/W : 4.43 SP3)	Rohde & Schwarz	ESU8	100386	2013/1/28	2014/1/31

The measuring equipment, which was utilized in performing the tests documented herein, has been calibrated in accordance with the manufacturer's recommendations for utilizing calibration equipment, which is traceable to recognized national standards.