

VX-450 (UHF) Series Alignment

Introduction

The VX-450 series are carefully aligned at the factory for the specified performance across the frequency range specified for each version. Realignment should therefore not be necessary except in the event of a component failure, or altering version type. All component replacement and service should be performed only by an authorized **Vertex Standard** representative, or the warranty policy may be void.

The following procedures cover the sometimes critical and tedious adjustments that are not normally required once the transceiver has left the factory. However, if damage occurs and some parts subsequently are placed, realignment may be required. If a sudden problem occurs during normal operation, it is likely due to component failure; realignment should not be done until after the faulty component has been replaced.

We recommend that servicing be performed only by authorized **Vertex Standard** service technicians who are experienced with the circuitry and fully equipped for repair and alignment. Therefore, if a fault is suspected, contact the dealer from whom the transceiver was purchased for instructions regarding repair. Authorized **Vertex Standard** service technicians realign all circuits and make complete performance checks to ensure compliance with factory specifications after replacing any faulty components.

Those who do undertake any of the following alignments are cautioned to proceed at their own risk. Problems caused by unauthorized attempts at realignment are not covered by the warranty policy. Also, **Vertex Standard** reserves the right to change circuits and alignment procedures in the interest of improved performance, without notifying owners.

Under no circumstances should any alignment be attempted unless the normal function and operation of the transceiver are clearly understood, the cause of the malfunction has been clearly pinpointed and any faulty components replaced, and realignment determined to be absolutely necessary.

The following test equipment (and thorough familiarity with its correct use) is necessary for complete realignment. Correction of problems caused by misalignment resulting from use of improper test equipment is not covered under the warranty policy. While most steps do not require all of the equipment listed, the interactions of some adjustments may require that more complex adjustments be performed afterwards.

Do not attempt to perform only a single step unless it is clearly isolated electrically from all other steps. Have all test equipment ready before beginning, and follow all of the steps in a section in the order presented.

Required Test Equipment

- RF Signal Generator with calibrated output level at 600MHz.
- Deviation Meter (linear detector)
- In-line Wattmeter with 5% accuracy at 600MHz.
- 50-Ω RF Dummy Load with power rating 10W at 600MHz.
- 4Ω/1W AF Dummy Load
- Regulated DC Power Supply (standard 7.5V DC, 3A)
- Frequency Counter with 0.2ppm accuracy at 600MHz.
- Audio Signal Generator (available to output 30Hz to 5kHz)
- AC Voltmeter
- DC Voltmeter
- IBM PC/compatible Computer with Microsoft Windows XP or later operating system
- Vertex Standard** FIF-10A Connection Cable & CE115 Programming software.

Alignment Preparation & Precautions

A 50-Ω RF Dummy Load and in-line wattmeter must be connected to the main antenna jack in all procedures that call for transmission, except where specified otherwise. Correct alignment is not possible with an antenna.

After completing one step, read the following step to determine whether the same test equipment will be required. If not, remove the test equipment (except dummy load and wattmeter, in connected) before proceeding.

Correct alignment requires that the ambient temperature be the same as that of the transceiver and test equipment, and that this temperature be held constant between 20 and 30°C (68 ~ 86 °F). When the transceiver is brought into the shop from hot or cold air, it should be allowed time to come to room temperature before alignment.

Whenever possible, alignments should be made with oscillator shields and circuit boards firmly affixed in place.

Also, the test equipment must be thoroughly warmed up before beginning.

Note: Signal levels in dB referred to in the alignment procedure are based on $0dB_{\mu} EMF = 1\mu V$.

Setup the test equipment as shown for transceiver alignment, apply 7.5V DC power to the transceiver. Refer to the drawings above for Alignment Points.

The transceiver must be programmed for use in the intended system before alignment is attempted. The RF parameters are loaded from the file during the alignment process.

In order to facilitate alignment over the complete switching range of the equipment it is recommended that the channel data in the transceiver is preset as the chart below.

Channels	Frequency (Simplex)
	UHF
LOW (F1)	400.100MHz
MID (F2)	435.100MHz
HIGH (F3)	469.900MHz

The alignment mode is accessed by "Alignment mode" command from the computer whilst switching on. And the alignment tool operates it automatically.

During the alignment mode, normal operation is suspended. Use the alignment tool program running on PC.

Before beginning alignment, connect the transceiver and PC using the FIF-10A Connection Cable, and run the CE115 Channel Programming Diskette, then download the data from the transceiver to the computer.

Then store this data in a disk file so that it can be uploaded when alignment is finished.

You should find the corresponding data file on the computer disk for the transceiver version you are aligning, containing channel settings for the high edge, middle and low edge of the transceiver's frequency range in channels 1,2 and 3, respectively. Up-load this file to the transceiver.

Low Band Edge	(Channel 1) : F1
Band Center	(Channel 2) : F2
High Band Edge	(Channel 3) : F3

The alignment tool outline

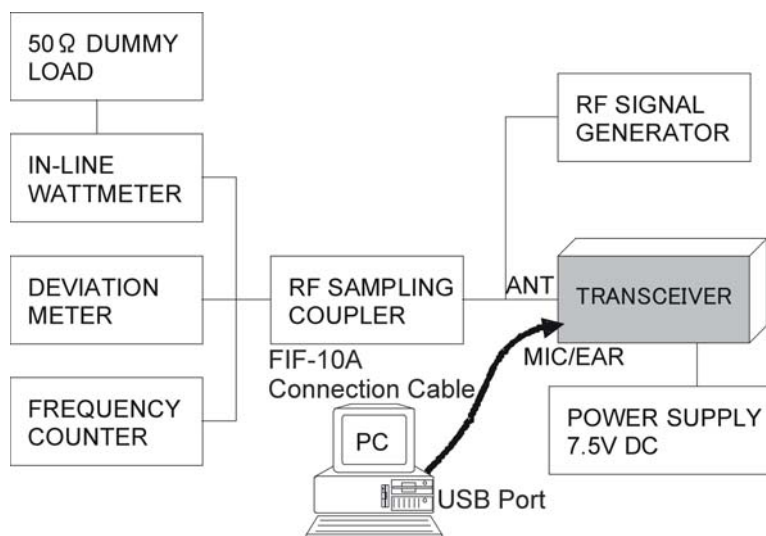

Installation the tool

Install the CE115 (Clone Editor) to your PC.

The re-alignment for VX-450 series may use the "Alignment" menu of CE115.

Action of the switches

When the transceiver is in alignment mode, the action of [PTT], [KEY] is ignored. All of the action is remote controlled by PC.

Basic sequence

The data displayed in screen of this tool is temporary data, and there is fear that the consistence of the displayed data and the data in the transceiver is failure when you do not keep the sequence, which is specified below.

Basic sequence

1. Enter the alignment mode
2. Data upload
3. Align data
4. Data download

When finish the alignment any parameter, to write it, the "OK" button is pushed. When "OK" is selected, data is written in the transceiver.

Menu of the tool

BASIC Alignment

In the Basic Alignment mode, the aligned data written in the radio will be able to re-align its alignment data. In this mode, there are many items to align with five points (F1, F2, F3, F4, F5) except "Frequency", "Mic Sense", "SQL/RSSI", and "Battery". The value of each parameter can be changed to desired position by <- / -> arrow key for up/down, direct number input and drag the mouse.

To enter the Basic Alignment Mode, select "Basic Alignment" in the main menu "Radio". It will start to "Upload" the written personalized data from the radio and to "Download" alignment data to the radio. Then pressing the button "OK" will start the Basic Alignment Mode.

Note; when all items are aligned, it is strongly recommended to align according to following order. The detail information is written in the help of CE115 (Clone Editor).

1. PLL Reference Frequency (Frequency)
2. RX Sensitivity (RX Tune)
3. Squelch (SQL/RSSI)
4. TX Power <High>
5. TX Power <Low>
6. Mic Sense
7. Maximum Deviation <Wide>
8. Maximum Deviation <Narrow>
9. Modulation Balance <Wide>
10. Modulation Balance <Narrow>
11. CTCSS Deviation <Wide>
12. CTCSS Deviation <Narrow>
13. DCS Deviation <Wide>
14. DCS Deviation <Narrow>
15. Battery