REPORT ON
Radio testing of the VERTEX STANDARD VX-7100-D0-50/VX-7200-D0-50
In accordance with ANSI/TIA/EIA-603, RSS-119

Report number TA000176

November 2004

GENERAL INFORMATION

MODEL NAME: VX-7100-D0-50/VX-7200-D0-50
 FCC ID: K6610603040
 MANUFACTURER: Vertex Standard Co., Ltd.
 TRADE NAME: VERTEX STANDARD
 EUT DESCRIPTION: VHF FM Transceiver
 SERIAL NUMBER: 4L000008
 VOLTAGE REQUIREMENTS: 13.6 [V]
 DC
 NUMBER OF CHANNELS: 501
 SPECIFICATION ARE REFERENCED ANSI/TIA/EIA-603
 RSS-119

TRANSMITTERS

TYPE OF EMISSION: 16K0F3E, 11K0F3E, 5K50F3E, 8
 FREQUENCY RANGE: 134 to 174 [MHz]
 POWER OUTPUT RATING: 10 to 50 [W]
 ___ Switchable
 x Variable
 ___ N/A
 MAXIMUM POWER RATING: 300 [W]
 INPUT IMPEDANCE (MIC): 600 [Ω]
 OUTPUT IMPEDANCE (RF): 50 [Ω]

RECEIVERS

FREQUENCY RANGE: to [MHz]
 INTERMEDIATE FREQUENCIES: 1st 50.85 [MHz]
 2nd -450 [kHz]
 INPUT IMPEDANCE (RF): 50 [Ω]
 OUTPUT IMPEDANCE (SP): 4 [Ω]
 AUDIO OUTPUT POWER: 4 [W]

This report was prepared by Vertex Standard Co., Ltd.

Test performed by Moto Kurihara

Date 19 / November /2004

VX-7100-D0-50/VX-7200-D0-50 Channel Settings

CH No.	Shown on LCD	Transmit Frequency [MHz]	Receive Frequency [MHz]	CH Spacing	Power *	Emission Type
1	134 0 Wide	134.000	134.000	25k	50W	F3E
2	154 1 Wide	154.100	154.100	25k	50W	F3E
3	174 0 Wide	174.000	174.000	25k	50W	F3E
4	134 0 Narrow	134.000	134.000	12.5k	50W	F3E
5	154 1 Narrow	154.100	154.100	12.5k	50W	F3E
6	174 0 Narrow	174.000	174.000	12.5k	50W	F3E
7	134 0 S Narr	134.000	134.000	6.25k	50W	F3E
8	154 1 S Narr	154.100	154.100	6.25k	50W	F3E
9	174 0 S Narr	174.000	174.000	6.25k	50W	F3E
10	134 0 Digit	134.000	134.000	12.5k	50W	F1E
11	154 1 Digit	154.100	154.100	12.5k	50W	F1E
12	174 0 Digit	174.000	174.000	12.5k	50W	F1E
13						
14						
15						
16						
17						
18						
19						
20						

*: Press [P4] key to set the low power (10W).

NAME OF TEST: R.F. Power Output (Conducted)
SPECIFICATION: 47 CFR 2.1046 (a)
GUIDE: ANSI/TIA/EIA-603, Paragraph 2.2.1
TEST EQUIPMENT: As per attached page

MEASUREMENT PROCEDURE

1. The EUT was connected to a resistive coaxial attenuator of normal load impedance, and the modulated output power was measured by means of an R.F. power meter.
2. Measurement accuracy is $\pm 4\%$

MEASUREMENT RESULTS

NOMINAL, MHz	CHANNEL	R.F. POWER, WATTS	
		LOW	HIGH
134.100	1	9.580	49.920
154.100	2	10.400	50.600
173.900	3	9.540	49.100

TRANSMITTER POWER CONDUCTED MEASUREMENTS

TEST 1: R.F. POWER OUTPUT
 TEST 2: FREQUENCY STABILITY

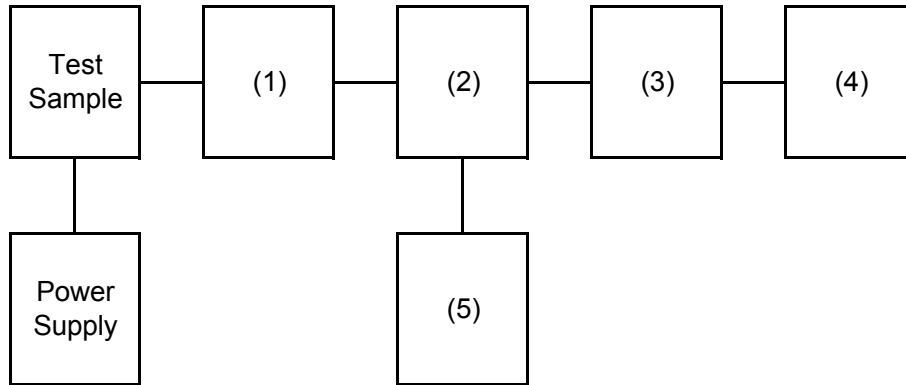

Instruments	Description	Serial Number
(1) COAXIAL ATTENUATOR	WEINSHELL 49-10-43	***
(2) RF COUPLER	ADVANTEST TR4153	***
(3) POWER SENSOR	Agilent 8482B	***
(4) POWER METER	Agilent 8901B POWER MODE	***
(5) FREQUENCY COUNTER	Agilent 8901B FREQUENCY MODE	***

TRANSMITTER POWER CONDUCTED MEASUREMENTS

TEST 1: R.F. POWER OUTPUT
 TEST 2: FREQUENCY STABILITY

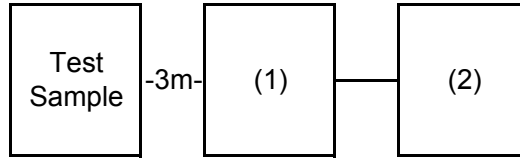

Instruments	Description	Serial Number
(1) ANTENNA	Schaffner-Chase CBL6143	***
(2) SPECTRUM ANALYZER	Agilent 8561B	***

NAME OF TEST: Unwanted Emissions (Conducted)
SPECIFICATION: 47 CFR 2.1051
GUIDE: ANSI/TIA/EIA-603, Paragraph 2.2.13
TEST EQUIPMENT: As per attached page

MEASUREMENT PROCEDURE

1. The emissions were measured for the worst case as follows:
 - (a): within a band of frequencies defined by the carrier frequency plus and minus one channel.
 - (b): from the lowest frequency generated in the EUT and to at least the 10th harmonic of the carrier frequency, or 40GHz, whichever is lower.
2. The magnitude of spurious emissions that are attenuated more than 20dB below the permissible value need not be specified.

3. MEASUREMENT RESULTS:

FREQUENCY OF CARRIER, MHz = 134.1 , 154.1 , 173.9

SPECTRUM SEARCHED, GHz = 0 to 10 x Fc

MAXIMUM RESPONSE, Hz = 2500

ALL OTHER EMISSIONS = >= 20dB BELOW LIMIT

TRANSMITTER SPURIOUS EMISSION

TEST 1: OCCUPIED BANDWIDTH (IN-BAND SPURIOUS)

TEST 2: OUT-OF-BAND SPURIOUS

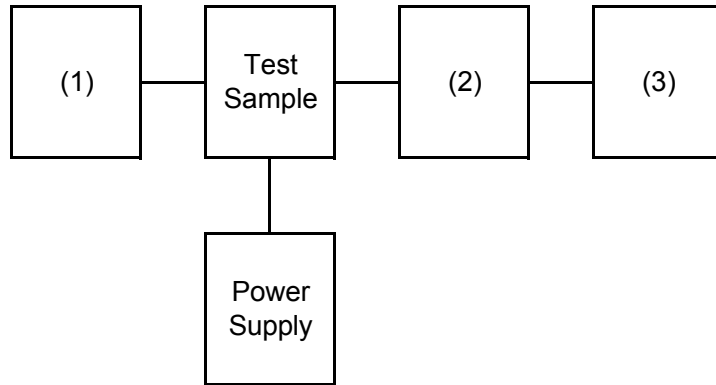

Instruments	Description	Serial Number
(1) AUDIO GENERATOR	Agilent 8903B	***
(2) COAXIAL ATTENUATOR	WEINSHELL 49-10-43	***
(2) COAXIAL ATTENUATOR	Agilent 8498A	***
(3) SPECTRUM ANALYZER	ADVANTEST TR4173	***

NAME OF TEST: Unwanted Emissions (Conducted)

LIMIT'S), dBc: $-(50+10 \times \text{LOG}(P)) = -67$ (50 Watts)
 $-(50+10 \times \text{LOG}(P)) = -60$ (10 Watts)

High Power

FREQUENCY TUNED, MHz	FREQUENCY EMISSION, MHz	LEVEL, dBm	LEVEL, dBc	MARGIN, dB
134.1000	268.2000	-31.3	-78.3	11.3
154.1000	308.2000	-34.1	-81.1	14.1
173.9000	347.8000	-30.1	-77.1	10.1

NAME OF TEST: Unwanted Emissions (Conducted)

LIMIT'S), dBc: $-(50+10 \times \text{LOG}(P)) = -67$ (50 Watts)
 $-(50+10 \times \text{LOG}(P)) = -60$ (10 Watts)

Low Power

FREQUENCY TUNED, MHz	FREQUENCY EMISSION, MHz	LEVEL, dBm	LEVEL, dBc	MARGIN, dB
134.1000	268.2000	-37.0	-77.0	17.0
173.9000	347.8000	-40.0	-80.0	20.0

NAME OF TEST: Field Strength of Spurious Radiation
SPECIFICATION: 47 CFR 2.1053 (a)
GUIDE: ANSI/TIA/EIA-603, Paragraph 1.2.12

MEASUREMENT PROCEDURE

1.2.12.1 Definition: Radiated spurious emissions are emissions from the equipment when transmitting load on a frequency or frequencies which are outside an occupied band sufficient to ensure transmission of information of required quality for the class of communications desired.

1.2.12.2 Method of measurement

- A) Connect the equipment as illustrated.
- B) Adjust the spectrum analyzer for the following settings:
- 1) Resolution Bandwidth $\leq 3\text{kHz}$
 - 2) Video Bandwidth $\geq 10\text{kHz}$
 - 3) Sweep Speed $\leq 2000\text{Hz/second}$
 - 4) Detector Mode = Positive Peak
- C) Place the transmitter to be tested on the turntable in the standard test site. The transmitter is transmitting into a non-radiating load which is placed on the turntable. The RF cable to this load should be of minimum length.

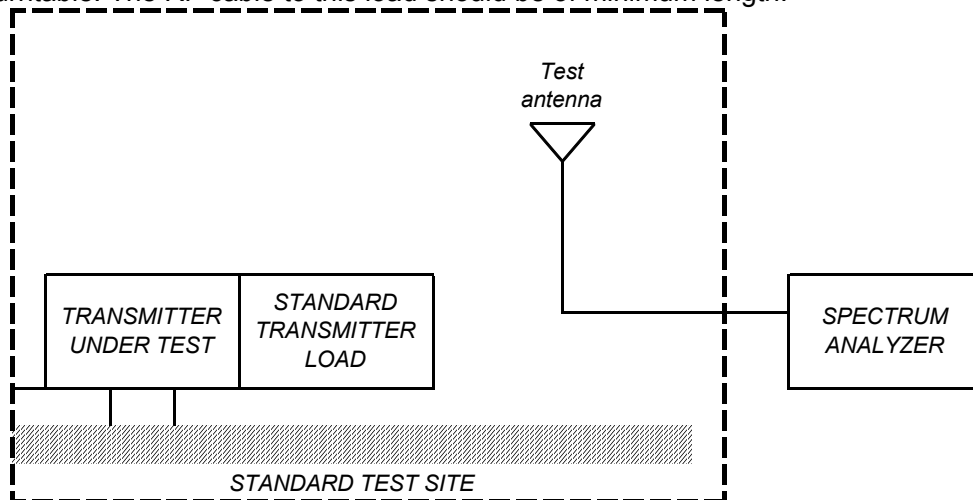

- D) For each spurious measurement the test antenna should be adjusted to the correct length for the frequency involved. This length may be determined from a calibration ruler supplied with the equipment. Measurements shall be made from the lowest radio frequency generated in the equipment to the tenth harmonic of the carrier, except for the region close to the carrier equal to \pm the test bandwidth (see section 1.3.4.4).
- E) For each spurious frequency, raise and lower the test antenna from 1 m to 4 m to obtain a maximum reading on the spectrum analyzer with the test antenna at horizontal polarity.

NAME OF TEST: Field Strength of Spurious Radiation

F) Repeat step E) for each spurious frequency with the test antenna polarized vertically

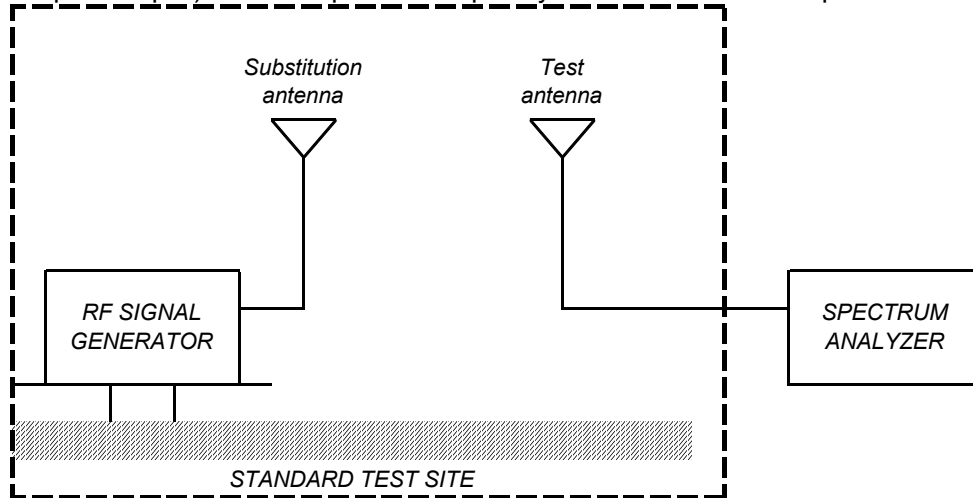

- G) Reconnect the equipment as illustrated.
- H) Keep the spectrum analyzer adjusted as in step B).
- I) Remove the transmitter and replace it with a substitution antenna (the antenna should be half-wavelength for each frequency involved).
The center of the substitution antenna should be approximately at the same location as the center of the transmitter. At lower frequencies, where the substitution antenna is very long, this will be impossible to achieve when the antenna is polarized vertically. In such case the lower end of the antenna should be 0.3m above the ground.
- J) Feed the substitution antenna at the transmitter end with a signal generator connected to the antenna by means of a non-radiating cable. With the antennas at both ends horizontally polarized and with the signal generator tuned to a particular spurious frequency, raise and lower the test antenna to obtain a maximum reading at the spectrum analyzer. Adjust the level of the signal generator output until the previous recorded maximum reading for the set of conditions is obtained. This should be done carefully repeating the adjustment of the test antenna and generator output.
- K) Repeat step J) with both antennas vertically polarized for each spurious frequency.
- L) Calculate power in dBm into a reference ideal half-wave dipole antenna by reducing the readings obtained in step J) and K) by the power loss in the cable between the generator and the antenna and further corrected for the gain of the substitution antenna used relative to an ideal half-wave dipole antenna.
- M) The levels recorded in step L) are absolute levels of radiated spurious emissions in dBm. The radiated spurious emissions in dB can be calculated by the following:

Radiated spurious emissions dB = $10\log_{10}(\text{TX power in watts}/0.001)$ - the levels in step L)

NAME OF TEST: Field Strength of Spurious Radiation

Note: It is permissible that other antennas provided can be referenced to a dipole.

Instruments	Description	Serial Number
TRANSDUCER	Schaffner-Chase CBL6143	***
TRANSDUCER	EMCO 3115	***
AMPLIFIER	Agilent 8447D	***
AMPLIFIER	Agilent 8449B	***
SPECTRUM ANALYZER	Agilent 8561B	***

NAME OF TEST: Field Strength of Spurious Radiation

LIMIT'S), dBc: $-(50+10 \times \text{LOG}(P)) = -67$ (50 Watts)

$-(50+10 \times \text{LOG}(P)) = -60$ (10 Watts)

High Power

FREQUENCY TUNED, MHz	FREQUENCY EMISSION, MHz	METER, dBuV	C.F., dB	ERP, dBm	ERP, dBc
134.1000	268.2000	51.7	24.3	-31.0	-78.0
154.1000	462.3000	44.3	30.9	-31.8	-78.8
134.1000	536.4000	40.3	27.0	-39.7	-86.7
154.1000	616.4000	44.4	29.7	-33.0	-80.0
173.9000	695.6000	41.7	31.9	-33.4	-80.4
134.1000	804.6000	42.8	32.3	-31.9	-78.9
173.9000	869.5000	49.3	31.4	-26.3	-73.3
154.1000	1386.9000	66.0	1.6	-39.4	-86.4

NAME OF TEST: Field Strength of Spurious Radiation

LIMIT'S), dBc: $-(50+10 \times \text{LOG}(P)) = -67$ (50 Watts)
 $-(50+10 \times \text{LOG}(P)) = -60$ (10 Watts)

Low Power

FREQUENCY TUNED, MHz	FREQUENCY EMISSION, MHz	METER, dBuV	C.F., dB	ERP, dBm	ERP, dBc
173.9000	869.5000	49.7	31.4	-25.9	-65.9

NAME OF TEST: Audio Low Pass Filter (Voice Input)
SPECIFICATION: 47 CFR 2.1047 (a)
GUIDE: ANSI/TIA/EIA-603, Paragraph 2.2.15
TEST EQUIPMENT: As per attached page

MEASUREMENT PROCEDURE

1. The EUT and test equipment were set up such that the audio input was connected at the input of the modulation limiter, and the modulated stage.
2. The audio output was connected at the output to the modulated stage.
3. MEASUREMENT RESULTS: ATTACHED

TRANSMITTER TEST SET-UP

TEST A: MODULATION CAPABILITY / DISTORTION
 TEST B: AUDIO FREQUENCY RESPONSE
 TEST C: HUM AND NOISE LEVEL
 TEST D: RESPONSE OF LOW PASS FILTER
 TEST E: MODULATION KIMITING

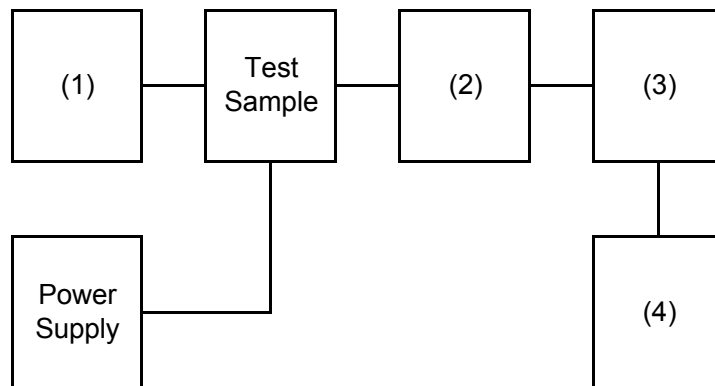

Instruments	Description	Serial Number
(1) AUDIO GENERATOR	Agilent 8903B	***
(2) COAXIAL ATTENUATOR	Agilent 8498A	***
(3) MODULATION ANALYZER	Agilent 8901B	***
(4) AUDIO ANALYZER	Agilent 8903B	***

NAME OF TEST: Audio Low Pass Filter (Voice Input)

STATE: 0 : General

Wide

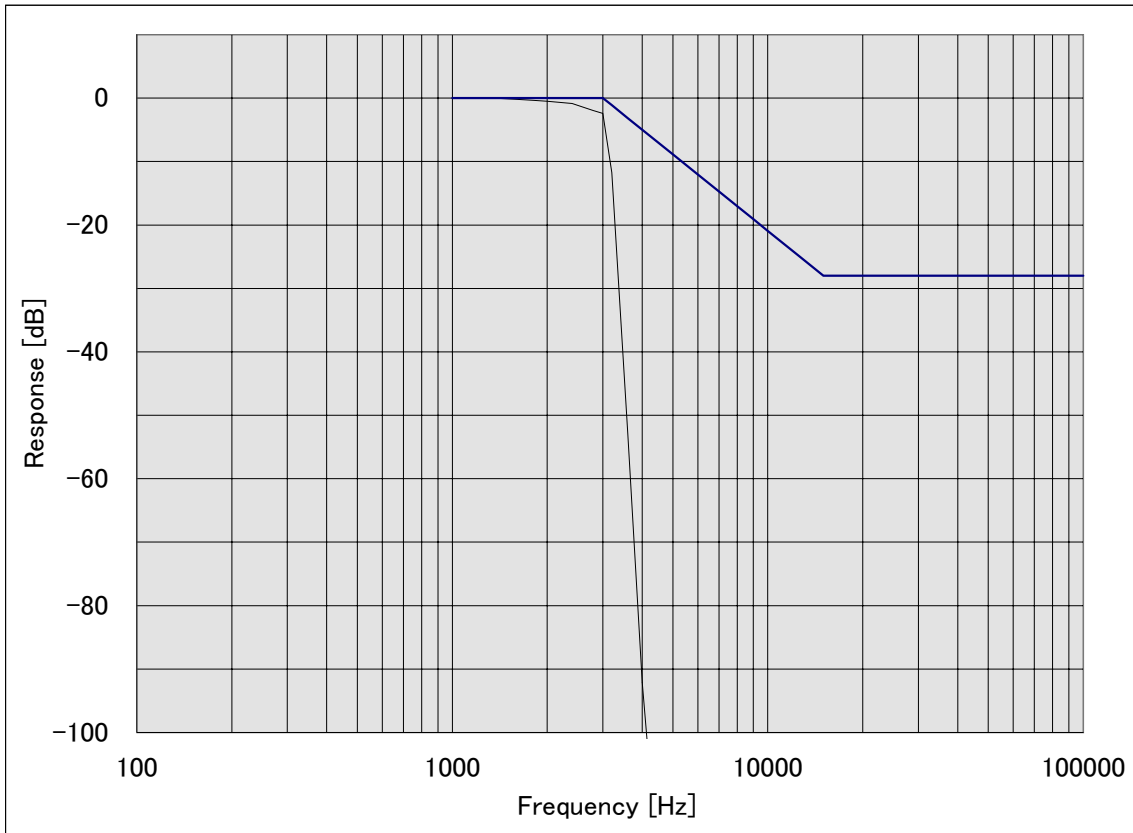

Narrow

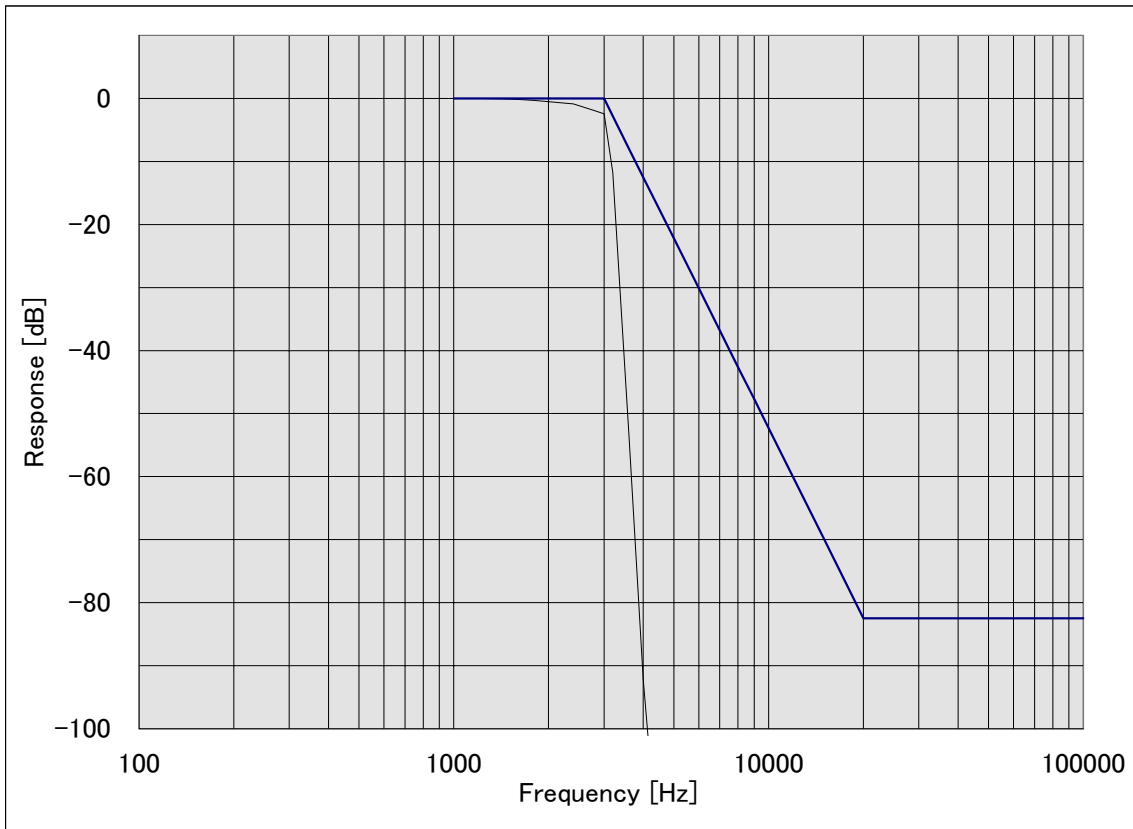

NAME OF TEST: Audio Frequency Response
SPECIFICATION: 47 CFR 2.1047 (a)
GUIDE: ANSI/TIA/EIA-603, Paragraph 2.2.6
TEST EQUIPMENT: As per previous page

MEASUREMENT PROCEDURE

1. The EUT and test equipment were set up as shown on the following page.
2. The audio signal generator was connected to the audio input circuit/microphone of the EUT.
3. The audio signal input was adjusted to obtain 20% modulation at 1kHz, and this point was taken as the 0dB reference level.
4. Which input levels hold constant and below limiting at all frequencies, the audio signal generator was varied from 100Hz to 5kHz.
5. The response in dB relative to 1kHz was then measured, using the Agilent 8901B modulation analyzer.
6. MEASUREMENT RESULTS: ATTACHED

NAME OF TEST: Audio Frequency Response

STATE: 0 : General

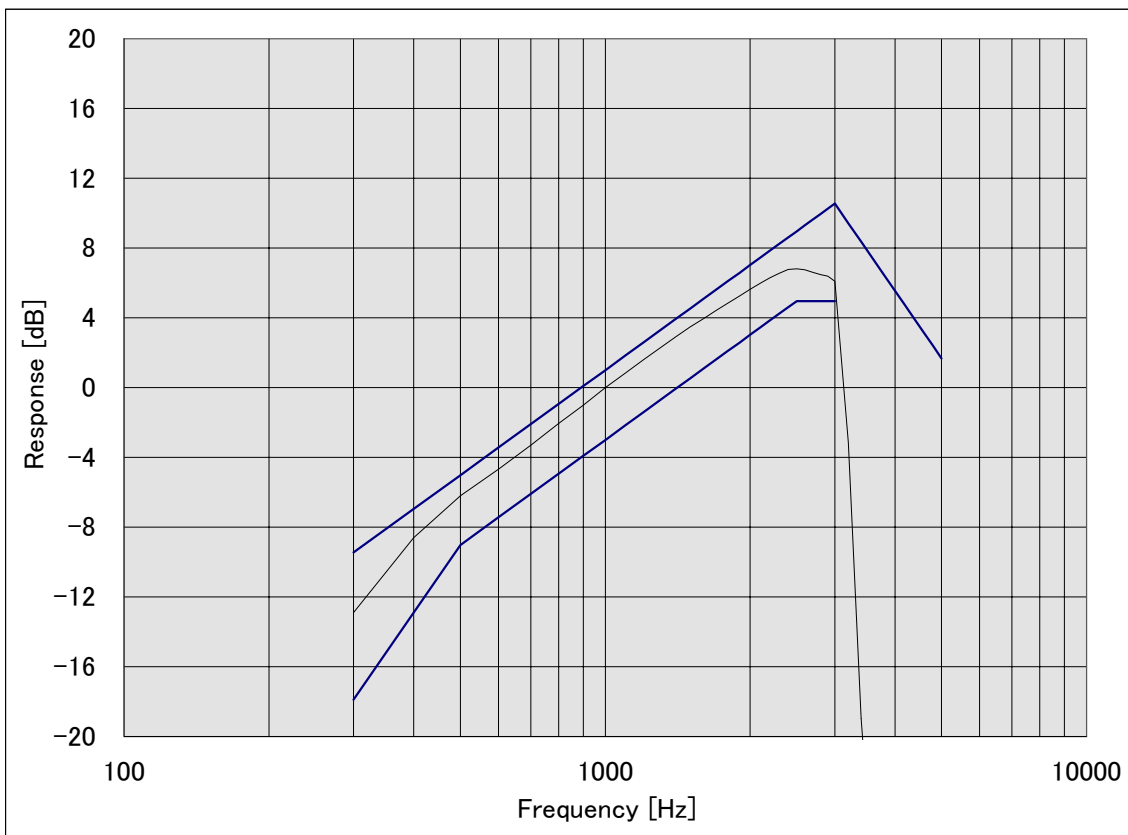

PEAK AUDIO FREQUENCY : 2500 [Hz]

NAME OF TEST: Modulation Limiting
SPECIFICATION: 47 CFR 2.1047 (b)
GUIDE: ANSI/TIA/EIA-603, Paragraph 2.2.3
TEST EQUIPMENT: As per previous page

MEASUREMENT PROCEDURE

1. The signal generator was connected to the input of the EUT as for "Frequency Response of the Modulating Circuit".
2. The modulation response was measured for each of three frequencies (one of which was the frequency of maximum response), and the input voltage was varied and was observed on an Agilent 8901B modulation analyzer.
3. The input level was varied from 30% modulation ($\pm 1.5\text{kHz}$ deviation) to at least 20dB higher than the saturation point.
4. Measurements were performed for both negative and positive modulation and the respective results were recorded.
5. MEASUREMENT RESULTS: ATTACHED

NAME OF TEST: Modulation Limiting

STATE: 0 : General

Positive Peak Wide

0 dB = 3.7 [mV]

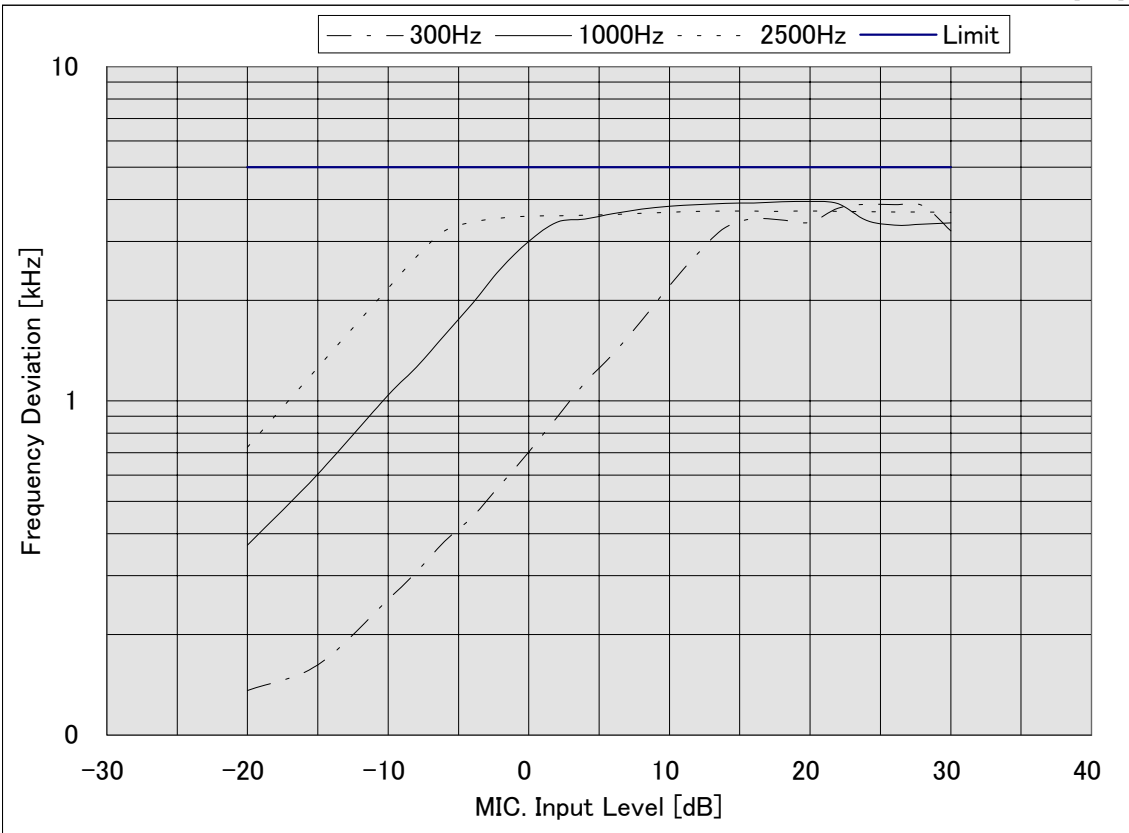

Negative Peak Wide

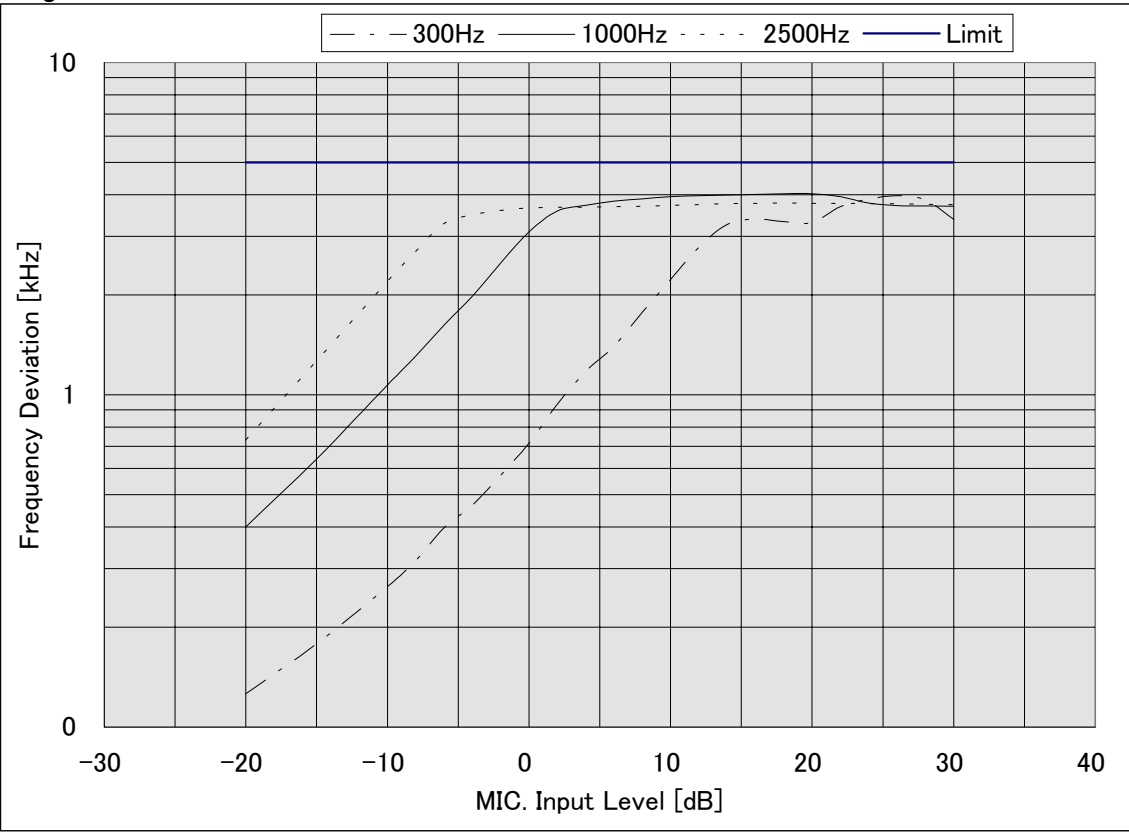

NAME OF TEST: Modulation Limiting

STATE: 0 : General

Positive Peak Narrow

0 dB = 3.7 [mV]

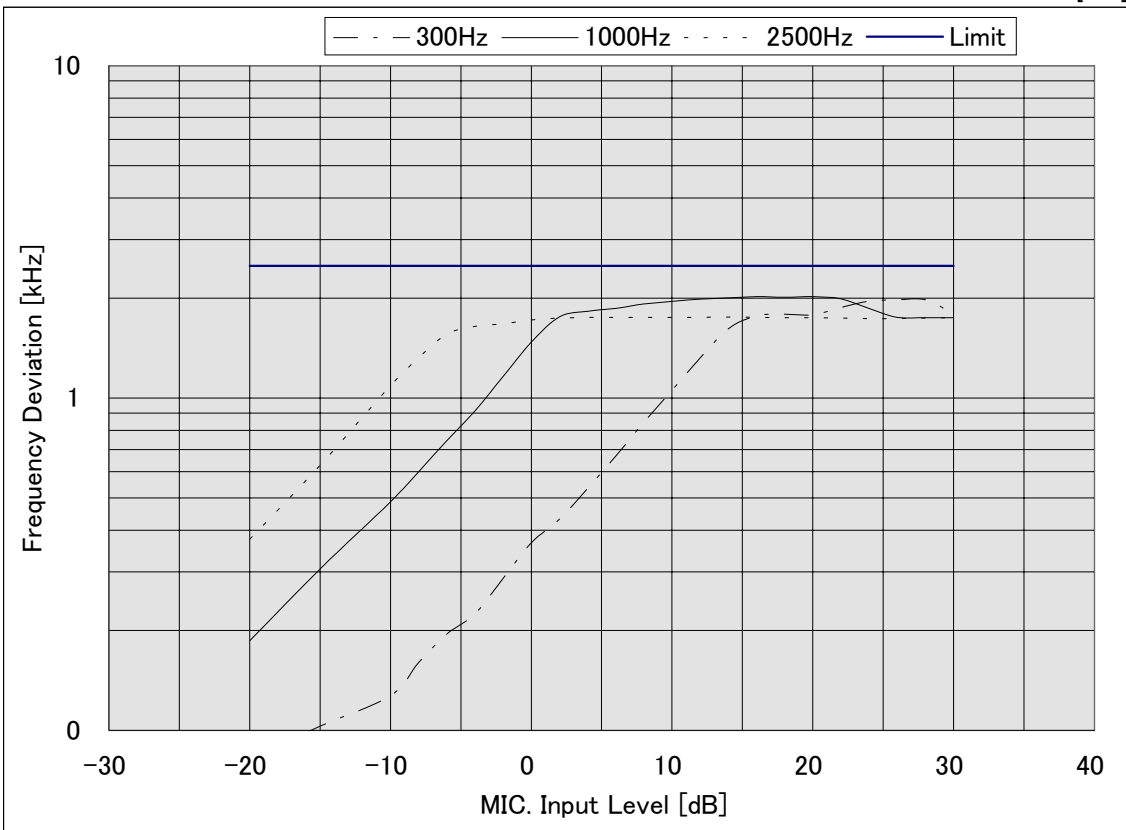

Negative Peak Narrow

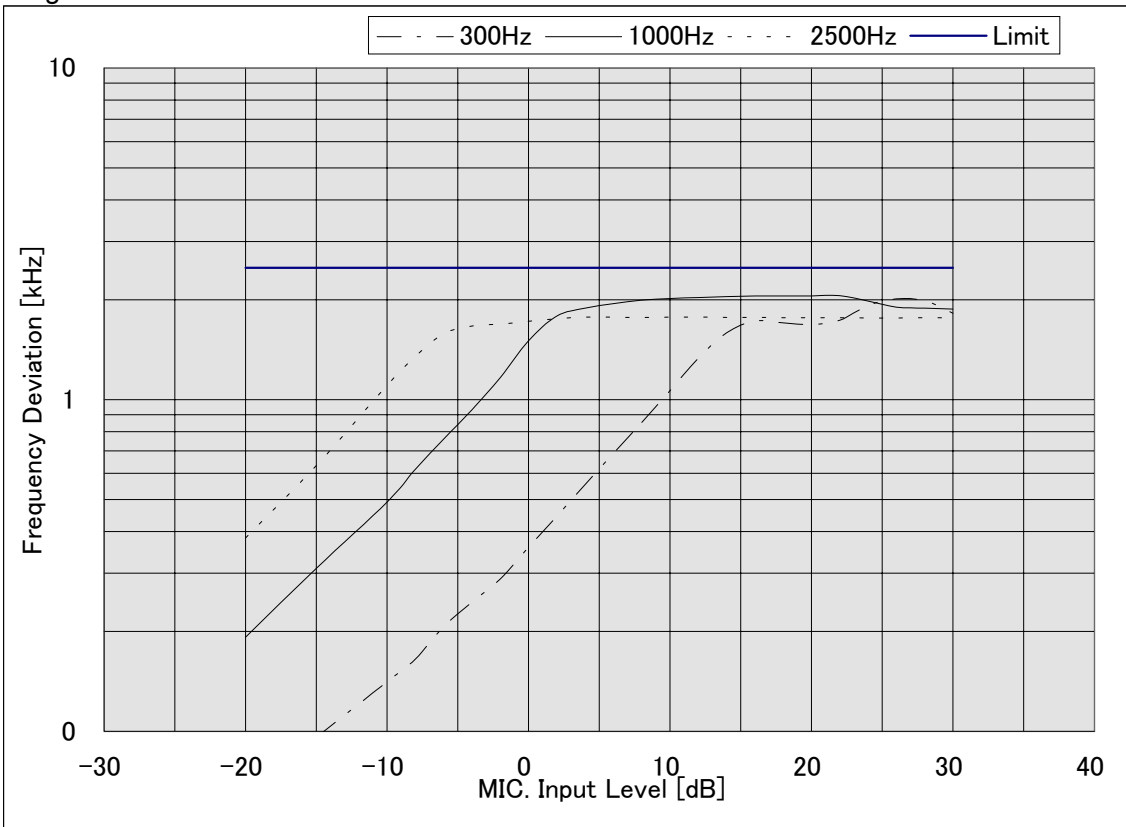

NAME OF TEST: Frequency Stability (Temperature Variation)
SPECIFICATION: 47 CFR 2.1055 (a) (1)
GUIDE: ANSI/TIA/EIA-603, Paragraph 2.2.2
TEST CONDITIONS: As indicated
TEST EQUIPMENT: As per previous page

MEASUREMENT PROCEDURE

1. The EUT and test equipment were set up as shown on the following page.
2. With all power removed, the temperature was decreased to -30°C and permitted to stabilize for three hours. Power was applied and the maximum change in frequency was noted within one minute.
3. With power OFF, the temperature was raised in 10°C steps. The sample was permitted to stabilize at each step for at least one-half hour. Power was applied and the maximum frequency change was noted within one minute.
4. The temperature tests were performed for the worst case.
5. MEASUREMENT RESULTS: ATTACHED

TRANSMITTER TEST SET-UP

- TEST A: OPERATIONAL STABILITY
- TEST B: CARRIER FREQUENCY STABILITY
- TEST C: OPERATIONAL PERFORMANCE STABILITY
- TEST D: HUMIDITY
- TEST E: VIBRATION
- TEST F: ENVIRONMENTAL TEMPERATURE
- TEST G: FREQUENCY STABILITY, TEMPERATURE VARIATION
- TEST H: FREQUENCY STABILITY, VOLTAGE VARIATION

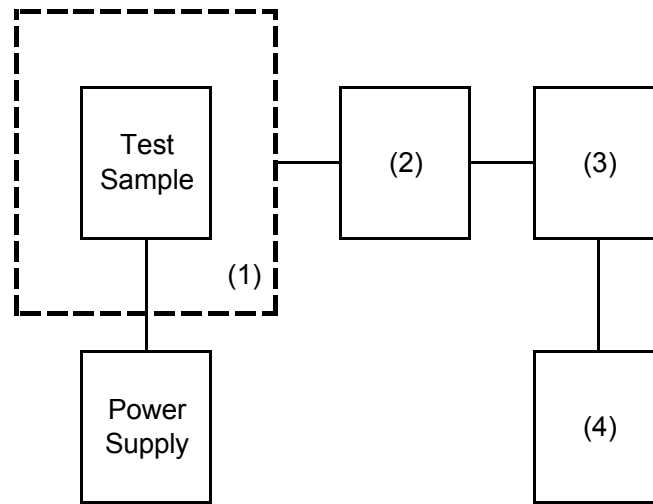

Instruments	Description	Serial Number
(1) TEMPERATURE CHAMBER	ETAC FX4100	***
(2) COAXIAL ATTENUATOR	Weinschel 53-30-33	***
(3) POWER METER	Agilent 436A	***
(4) FREQUENCY COUNTER	Agilent 8901B FREQUENCY MODE	***

NAME OF TEST: Frequency Stability (Temperature Variation)

STATE: 0 : General

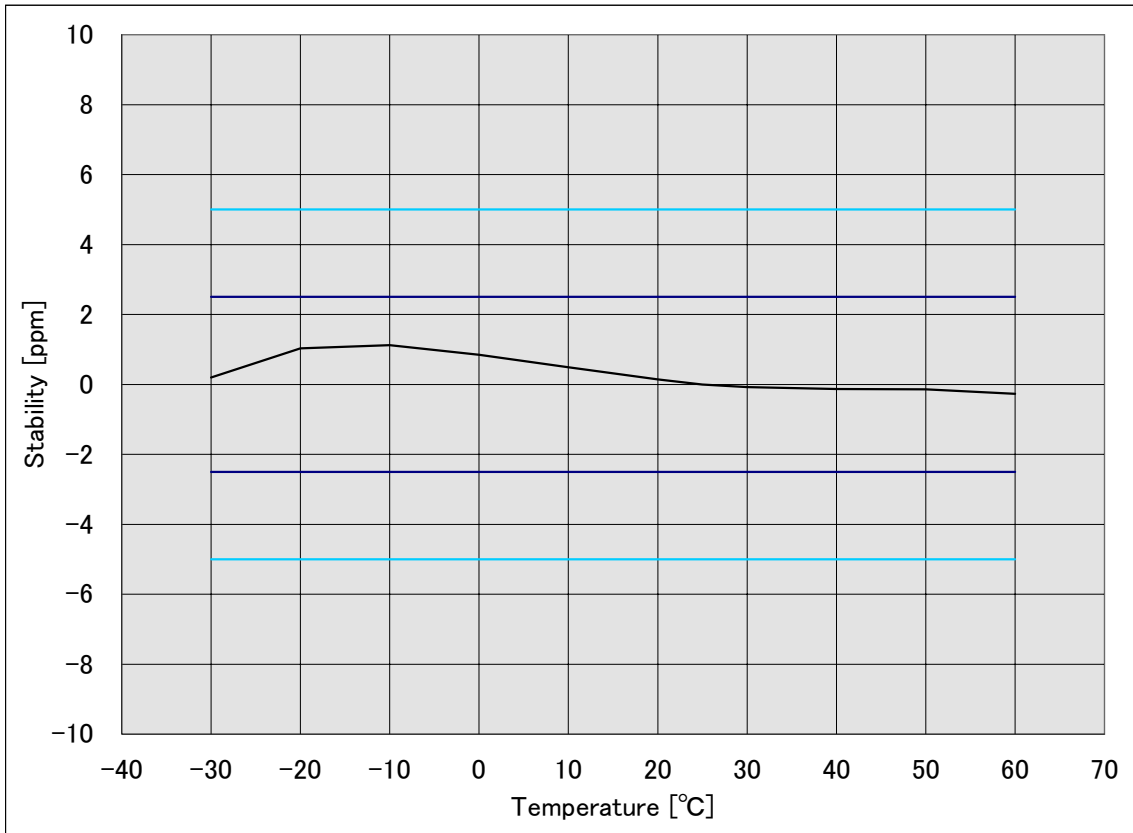

NAME OF TEST: Frequency Stability (Voltage Variation)
SPECIFICATION: 47 CFR 2.1055 (b)
GUIDE: ANSI/TIA/EIA-603, Paragraph 2.2.2
TEST EQUIPMENT: As per previous page

MEASUREMENT PROCEDURE

1. The EUT was placed in a temperature chamber at 25±5°C and connected as for "Frequency Stability - Temperature Variation" test.
2. The power supply voltage to the EUT was varied from 85% to 115% of the nominal value measured at the input to the EUT.
3. The variation in frequency was measured for the worst case.

RESULTS: Frequency Stability (Voltage Variation)

STATE: 0 : General

LIMIT', ppm = 2.5
 LIMIT', Hz = 385

% of STV	Voltage	Frequency, MHz	Change, Hz	Change, ppm
85	11.56	154.100000	0	0.00
100	13.60	154.100000	0	0.00
115	15.64	154.100000	0	0.00

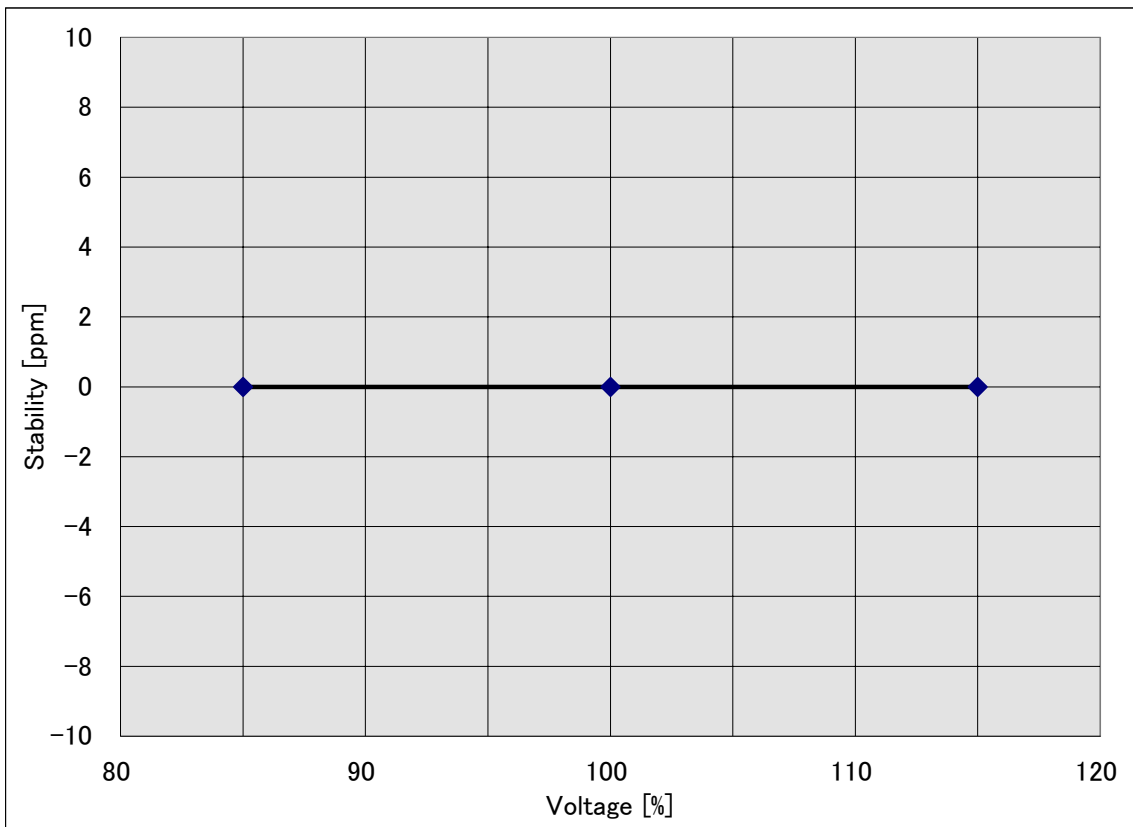

NAME OF TEST: Necessary Bandwidth and Emission Bandwidth
SPECIFICATION: 47 CFR 2.202 (g)

MODULATION = 16K0F3E

NECESSARY BANDWIDTH CALCULATION:

MAXIMUM MODULATION (M), kHz = 3
MAXIMUM DEVIATION (D), kHz = 5
CONSTANT FACTOR (K) = 1
NECESSARY BANDWIDTH (B_N), kHz = (2xM) + (2xDxK)
= ###

MODULATION = 11K0F3E

NECESSARY BANDWIDTH CALCULATION:

MAXIMUM MODULATION (M), kHz = 3
MAXIMUM DEVIATION (D), kHz = 3
CONSTANT FACTOR (K) = 1
NECESSARY BANDWIDTH (B_N), kHz = (2xM) + (2xDxK)
= ###

MODULATION = 5K50F3E

NECESSARY BANDWIDTH CALCULATION:

MAXIMUM MODULATION (M), kHz = 1.5
MAXIMUM DEVIATION (D), kHz = 1.3
CONSTANT FACTOR (K) = 1
NECESSARY BANDWIDTH (B_N), kHz = (2xM) + (2xDxK)
= 5.5

NAME OF TEST: Receiver Spurious Emissions (Conducted)

STATE: 0 : General

All other emissions in the required measurement range were more than 20dB below the required limits.

MEASUREMENT RESULTS

<u>FREQUENCY TUNED, MHz</u>	<u>FREQUENCY EMISSION, MHz</u>	<u>LEVEL, dBm</u>	<u>LEVEL, nW</u>
134.100	1849.500	-69.0	0.1

NAME OF TEST: Receiver Spurious Emissions (Radiated)

STATE: 0 : General

All other emissions in the required measurement range were more than 20dB below the required limits.

MEASUREMENT RESULTS

FREQUENCY TUNED, MHz	FREQUENCY EMISSION, MHz	LEVEL, dBuV	@m	CF, dB	uV/m
154.100	204.950	27.6	3	-4.5	32.1
173.900	224.750	27.2	3	-4.7	31.9
134.100	369.900	34.4	3	-3.1	37.5
173.900	449.500	33.1	3	-3.7	36.8
134.100	1109.700	24.1	3	-11.2	35.3
173.900	1123.750	25.8	3	-11.0	36.8
154.100	1434.650	28.6	3	-7.7	36.3
173.900	1573.250	35.5	3	-6.6	42.1
154.100	1639.600	32.4	3	-6.1	38.5
173.900	1798.000	33.5	3	-5.0	38.5
173.900	2022.750	41.2	3	-3.4	44.6
134.100	2034.450	41.6	3	-3.4	45.0
154.100	2049.500	43.5	3	-3.3	46.8
173.900	2247.500	49.6	3	-1.8	51.4

Occupied Bandwidth

CENTER FREQ 133.999 MHz
 SPAN 100 KHz
 REF LEVEL 46.1 dBm
 /DIV 10 dB/
 ATT 20 dB
 OFFSET 34 dB
 RES BW 300 Hz
 VIDEO BW 300 Hz
 SWEEP TIME 5 s
 AVG

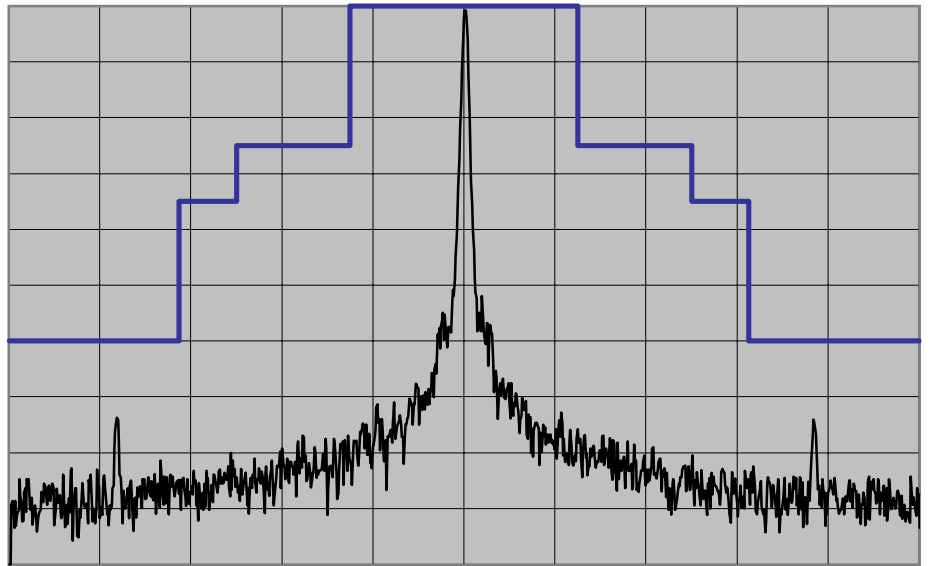

Model Name	VX-7200-D0-50	Transmit Frequency	134 MHz
Serial Number	4L000008	Channel Spacing	25 kHz
Power Setting	High	Modulation	None

CENTER FREQ 133.999 MHz
 SPAN 100 KHz
 REF LEVEL 46.1 dBm
 /DIV 10 dB/
 ATT 20 dB
 OFFSET 34 dB
 RES BW 300 Hz
 VIDEO BW 300 Hz
 SWEEP TIME 5 s
 AVG

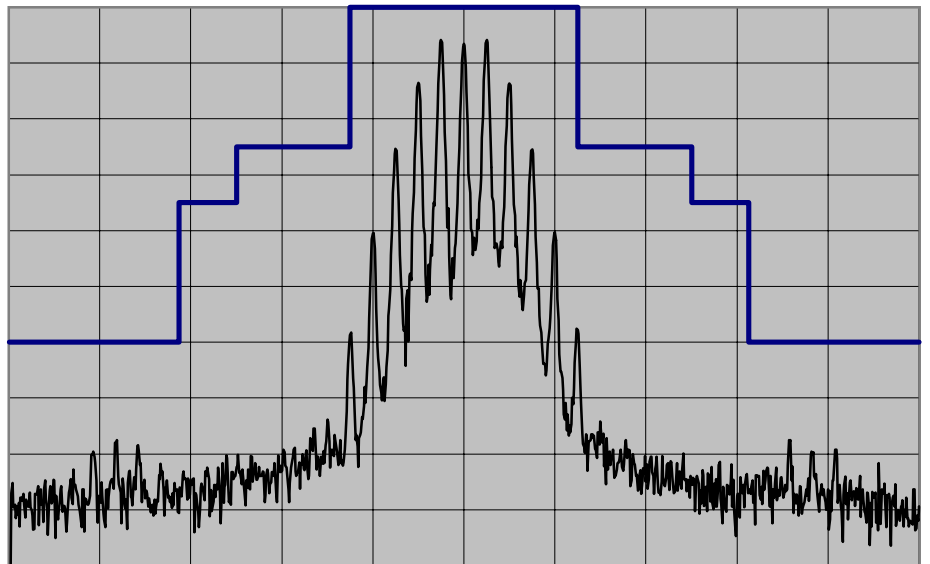

Model Name	VX-7200-D0-50	Transmit Frequency	134 MHz
Serial Number	4L000008	Channel Spacing	25 kHz
Power Setting	High	Modulation	Voice

Occupied Bandwidth

CENTER FREQ 154.099 MHz
 SPAN 100 KHz
 REF LEVEL 46.3 dBm
 /DIV 10 dB/
 ATT 20 dB
 OFFSET 34 dB
 RES BW 300 Hz
 VIDEO BW 300 Hz
 SWEEP TIME 5 s
 AVG

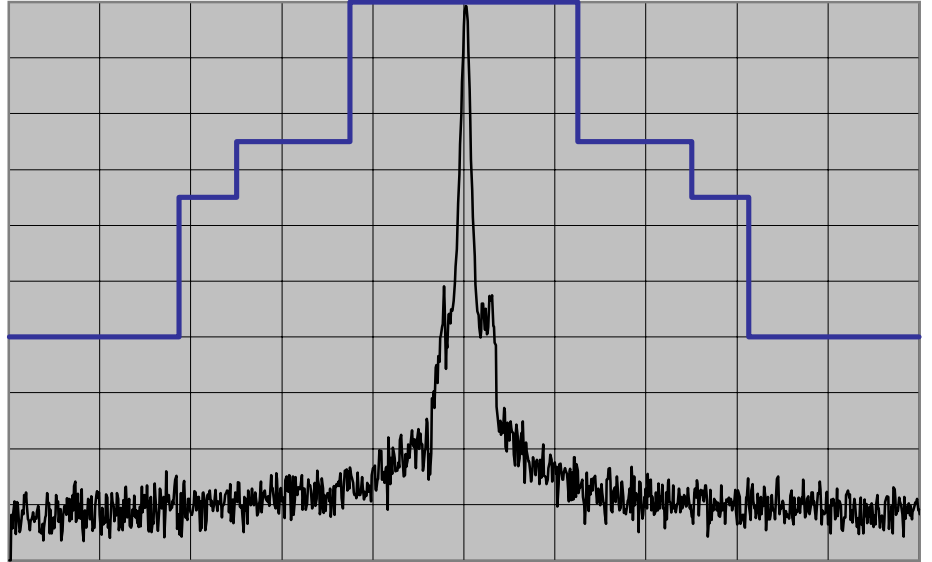

Model Name	VX-7200-D0-50	Transmit Frequency	154.1 MHz
Serial Number	4L000008	Channel Spacing	25 kHz
Power Setting	High	Modulation	None

CENTER FREQ 154.099 MHz
 SPAN 100 KHz
 REF LEVEL 46.3 dBm
 /DIV 10 dB/
 ATT 20 dB
 OFFSET 34 dB
 RES BW 300 Hz
 VIDEO BW 300 Hz
 SWEEP TIME 5 s
 AVG

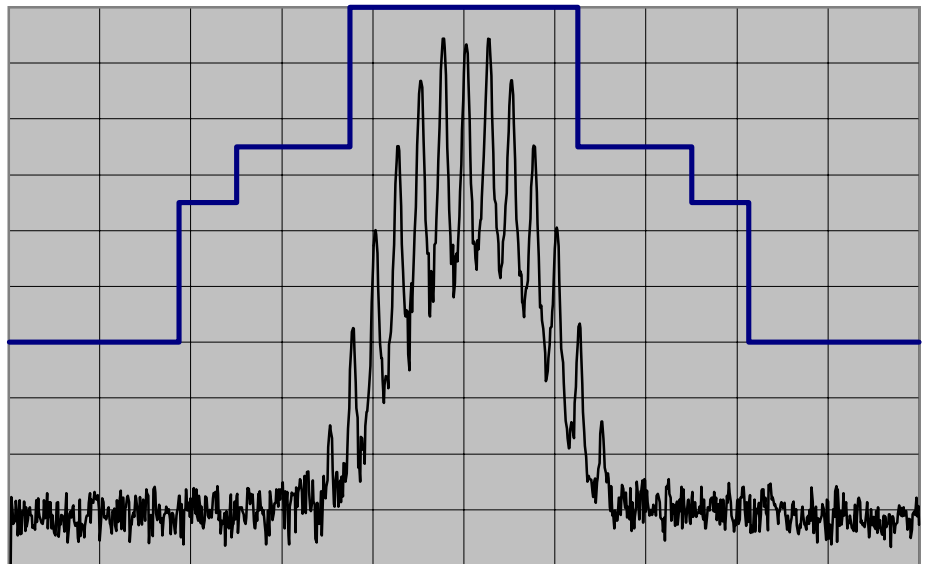

Model Name	VX-7200-D0-50	Transmit Frequency	154.1 MHz
Serial Number	4L000008	Channel Spacing	25 kHz
Power Setting	High	Modulation	Voice

Occupied Bandwidth

CENTER FREQ 173.999 MHz
 SPAN 100 KHz
 REF LEVEL 46.3 dBm
 /DIV 10 dB/
 ATT 20 dB
 OFFSET 34 dB
 RES BW 300 Hz
 VIDEO BW 300 Hz
 SWEEP TIME 5 s
 AVG

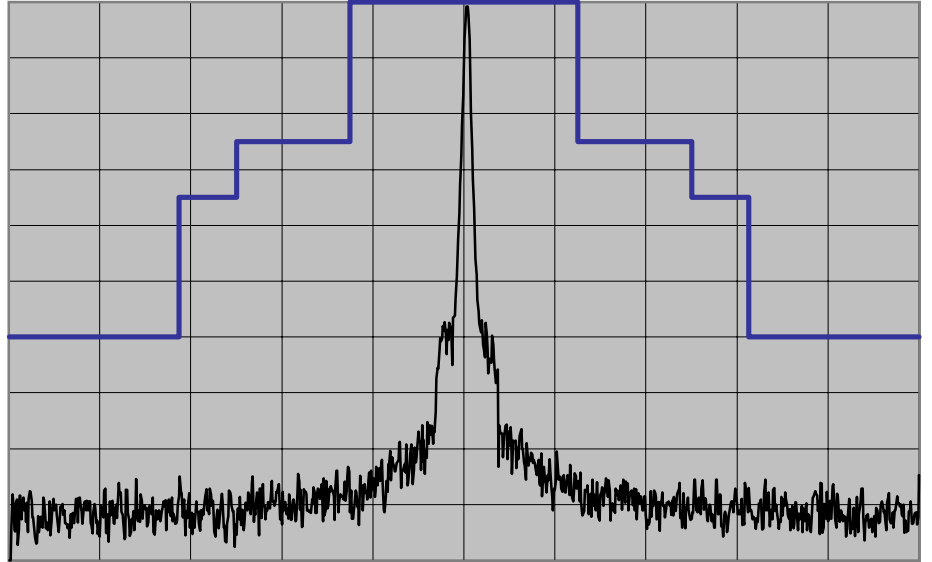

Model Name	VX-7200-D0-50	Transmit Frequency	174 MHz
Serial Number	4L000008	Channel Spacing	25 kHz
Power Setting	High	Modulation	None

CENTER FREQ 173.999 MHz
 SPAN 100 KHz
 REF LEVEL 46.3 dBm
 /DIV 10 dB/
 ATT 20 dB
 OFFSET 34 dB
 RES BW 300 Hz
 VIDEO BW 300 Hz
 SWEEP TIME 5 s
 AVG

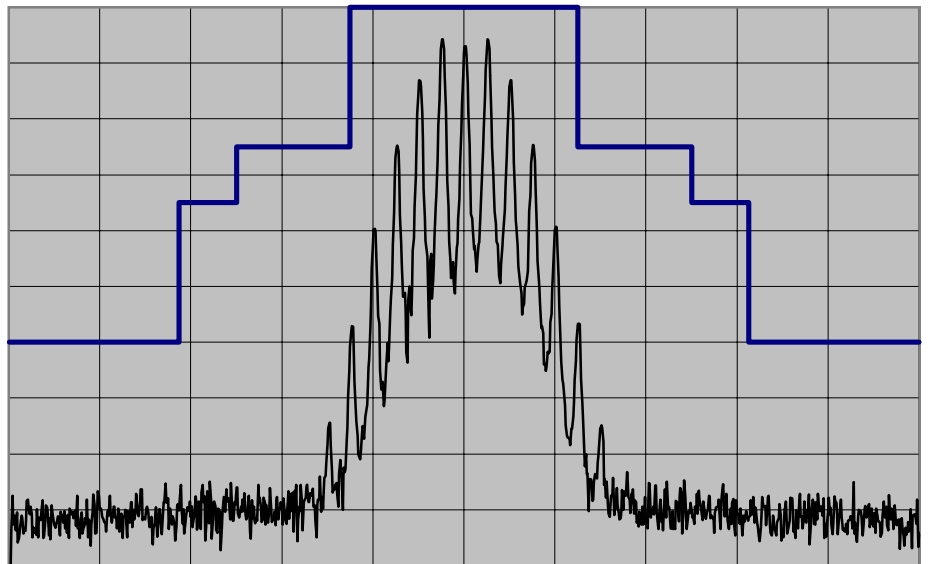

Model Name	VX-7200-D0-50	Transmit Frequency	174 MHz
Serial Number	4L000008	Channel Spacing	25 kHz
Power Setting	High	Modulation	Voice

Occupied Bandwidth

CENTER FREQ 133.9998 MHz
 SPAN 50 KHz

 REF LEVEL 45.7 dBm
 /DIV 10 dB/
 ATT 20 dB
 OFFSET 34 dB

 RES BW 100 Hz
 VIDEO BW 100 Hz

 SWEEP TIME 30 s
 AVG

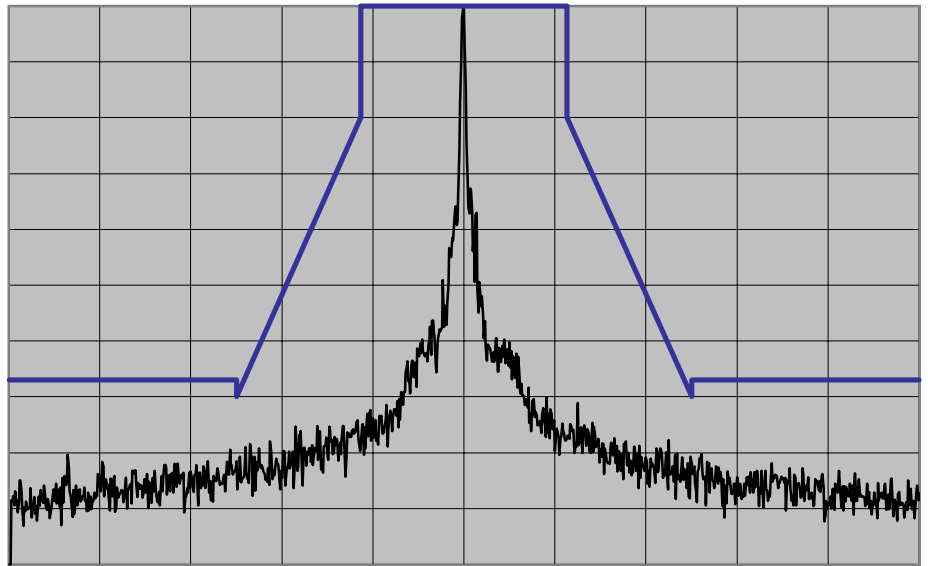

Model Name	VX-7200-D0-50	Transmit Frequency	134 MHz
Serial Number	4L000008	Channel Spacing	12.5 kHz
Power Setting	High	Modulation	None

CENTER FREQ 133.9998 MHz
 SPAN 50 KHz

 REF LEVEL 45.7 dBm
 /DIV 10 dB/
 ATT 20 dB
 OFFSET 34 dB

 RES BW 100 Hz
 VIDEO BW 100 Hz

 SWEEP TIME 30 s
 AVG

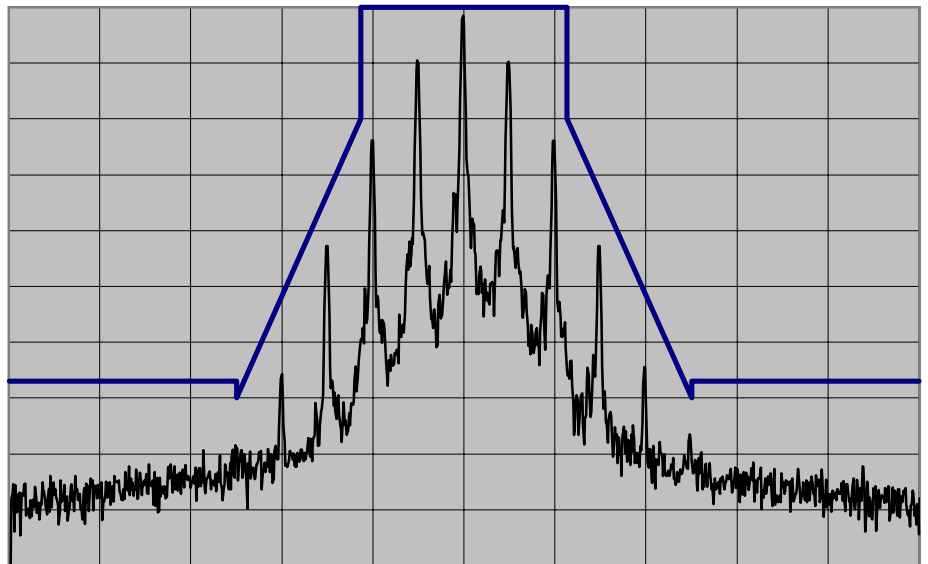

Model Name	VX-7200-D0-50	Transmit Frequency	134 MHz
Serial Number	4L000008	Channel Spacing	12.5 kHz
Power Setting	High	Modulation	Voice

Occupied Bandwidth

CENTER FREQ 154.0998 MHz
 SPAN 50 KHz
 REF LEVEL 46 dBm
 /DIV 10 dB/
 ATT 20 dB
 OFFSET 34 dB
 RES BW 100 Hz
 VIDEO BW 100 Hz
 SWEEP TIME 30 s
 AVG

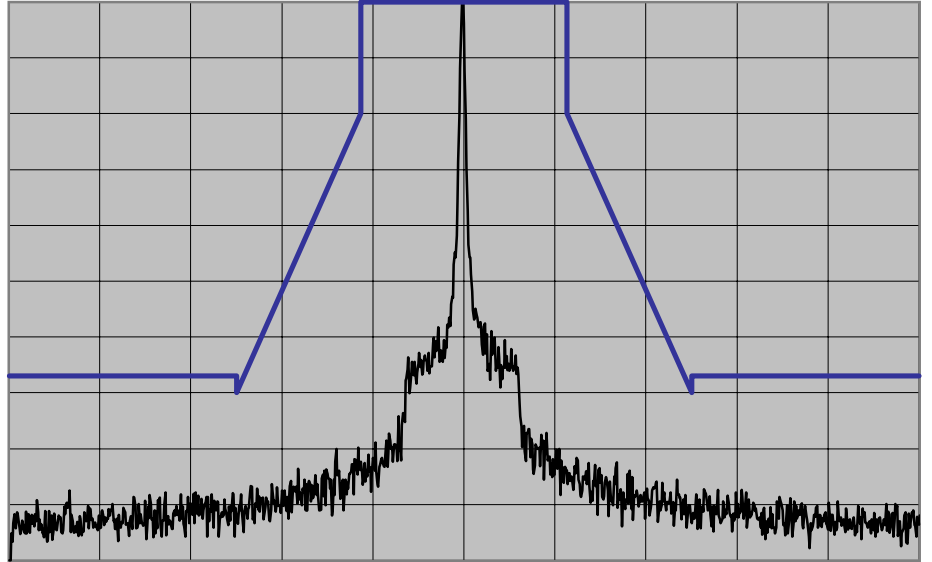

Model Name	VX-7200-D0-50	Transmit Frequency	154.1 MHz
Serial Number	4L000008	Channel Spacing	12.5 kHz
Power Setting	High	Modulation	None

CENTER FREQ 154.0998 MHz
 SPAN 50 KHz
 REF LEVEL 46 dBm
 /DIV 10 dB/
 ATT 20 dB
 OFFSET 34 dB
 RES BW 100 Hz
 VIDEO BW 100 Hz
 SWEEP TIME 30 s
 AVG

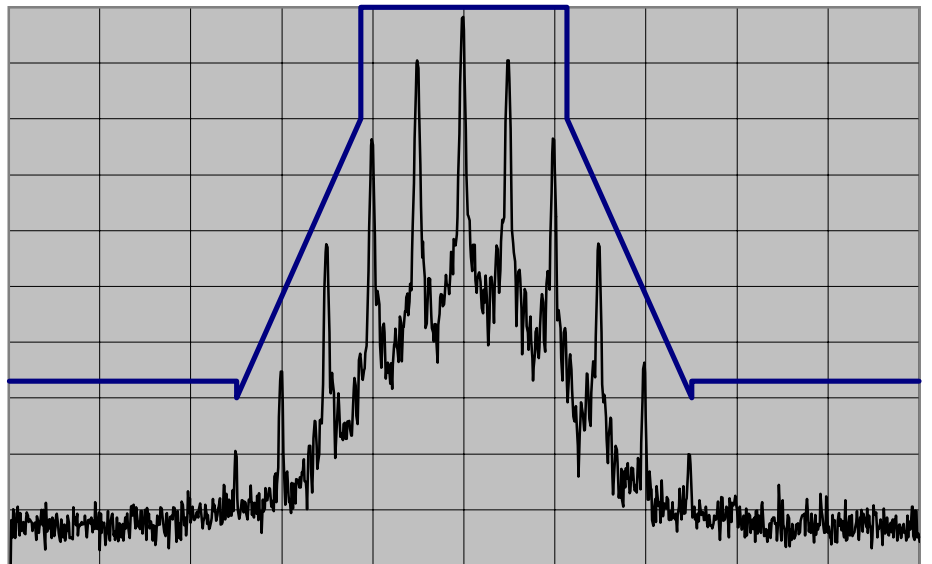

Model Name	VX-7200-D0-50	Transmit Frequency	154.1 MHz
Serial Number	4L000008	Channel Spacing	12.5 kHz
Power Setting	High	Modulation	Voice

Occupied Bandwidth

CENTER FREQ 173.9997 MHz
 SPAN 50 KHz
 REF LEVEL 46.3 dBm
 /DIV 10 dB/
 ATT 20 dB
 OFFSET 34 dB
 RES BW 100 Hz
 VIDEO BW 100 Hz
 SWEEP TIME 30 s
 AVG

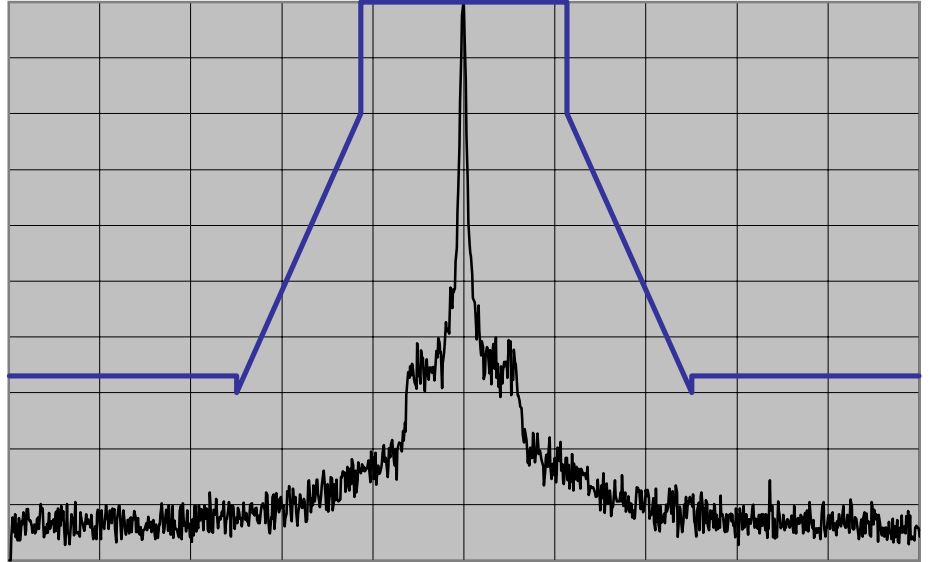

Model Name	VX-7200-D0-50	Transmit Frequency	174 MHz
Serial Number	4L000008	Channel Spacing	12.5 kHz
Power Setting	High	Modulation	None

CENTER FREQ 173.9997 MHz
 SPAN 50 KHz
 REF LEVEL 46.3 dBm
 /DIV 10 dB/
 ATT 20 dB
 OFFSET 34 dB
 RES BW 100 Hz
 VIDEO BW 100 Hz
 SWEEP TIME 30 s
 AVG

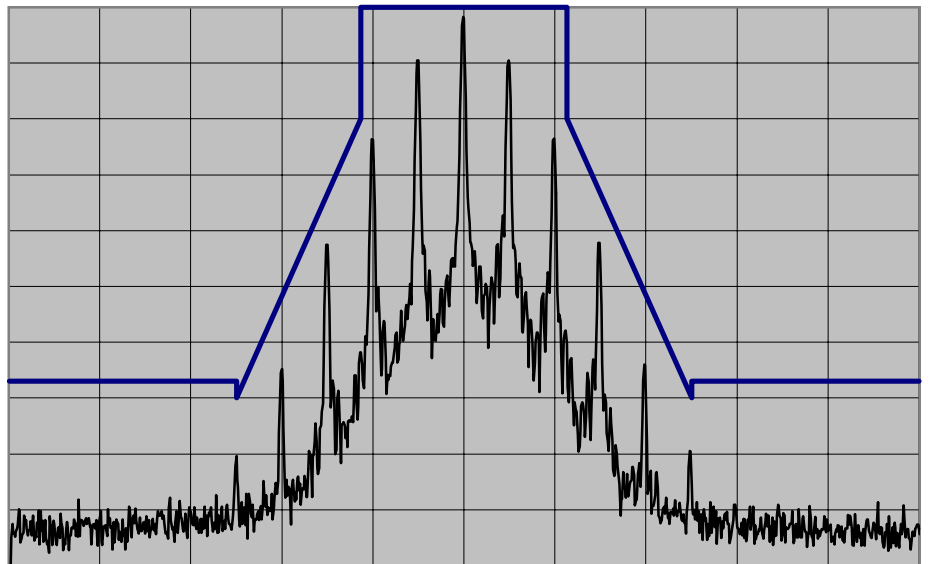

Model Name	VX-7200-D0-50	Transmit Frequency	174 MHz
Serial Number	4L000008	Channel Spacing	12.5 kHz
Power Setting	High	Modulation	Voice

Occupied Bandwidth

CENTER FREQ 133.9998 MHz
 SPAN 50 KHz
 REF LEVEL 45.7 dBm
 /DIV 10 dB/
 ATT 20 dB
 OFFSET 34 dB
 RES BW 100 Hz
 VIDEO BW 100 Hz
 SWEEP TIME 30 s
 AVG

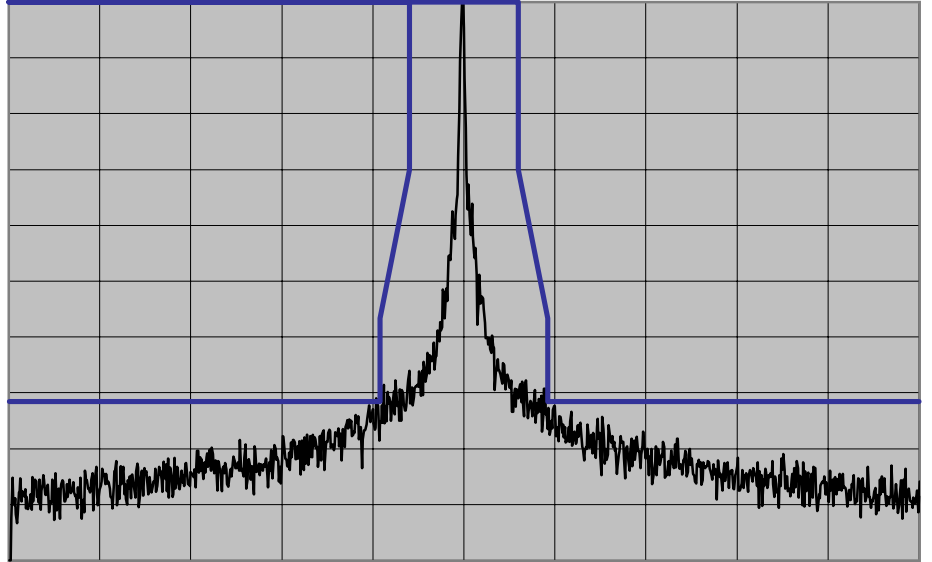

Model Name	VX-7200-D0-50	Transmit Frequency	134 MHz
Serial Number	4L000008	Channel Spacing	6.25 kHz
Power Setting	High	Modulation	None

CENTER FREQ 133.9998 MHz
 SPAN 50 KHz
 REF LEVEL 45.7 dBm
 /DIV 10 dB/
 ATT 20 dB
 OFFSET 34 dB
 RES BW 100 Hz
 VIDEO BW 100 Hz
 SWEEP TIME 30 s
 AVG

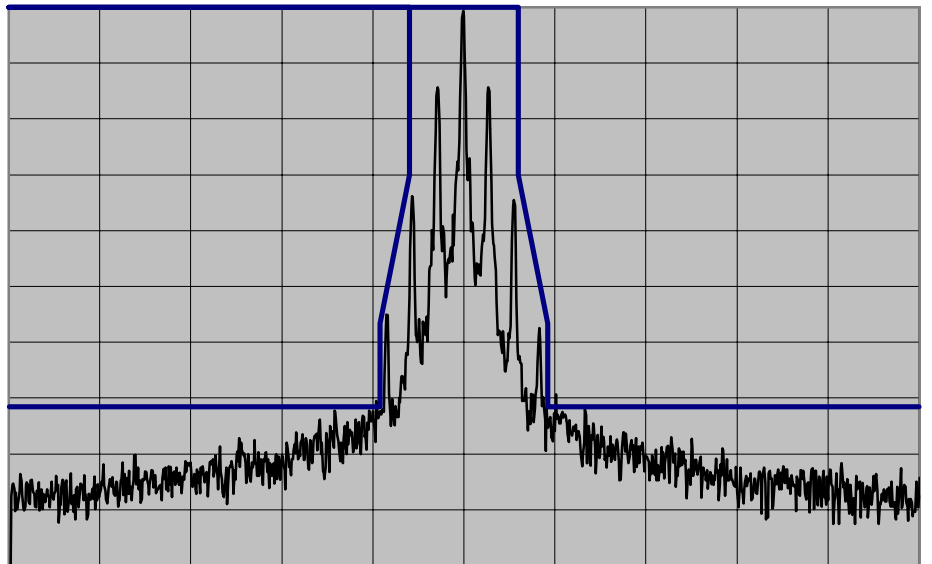

Model Name	VX-7200-D0-50	Transmit Frequency	134 MHz
Serial Number	4L000008	Channel Spacing	6.25 kHz
Power Setting	High	Modulation	Voice

Occupied Bandwidth

CENTER FREQ 154.0998 MHz
 SPAN 50 KHz

 REF LEVEL 46.3 dBm
 /DIV 10 dB/
 ATT 20 dB
 OFFSET 34 dB

 RES BW 100 Hz
 VIDEO BW 100 Hz

 SWEEP TIME 30 s
 AVG

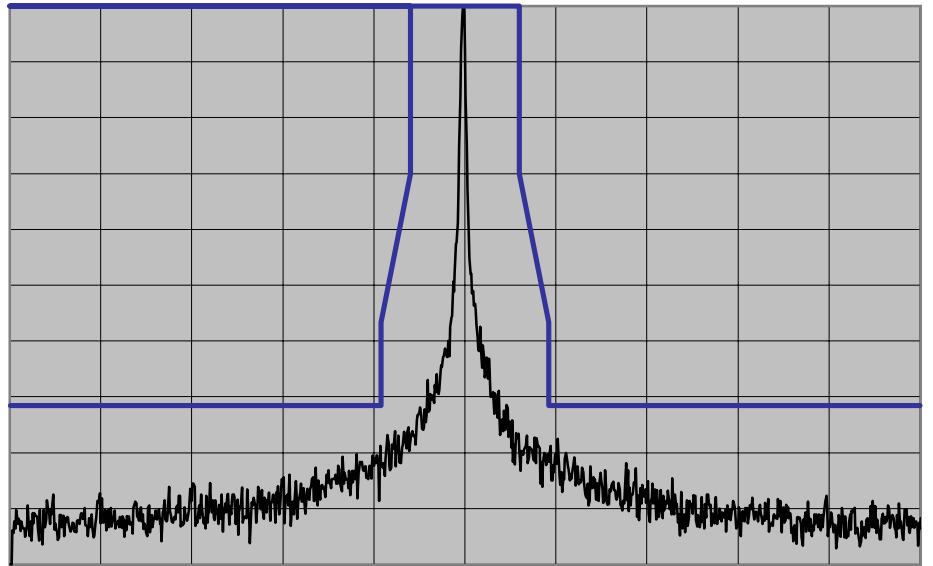

Model Name	VX-7200-D0-50	Transmit Frequency	154.1 MHz
Serial Number	4L000008	Channel Spacing	6.25 kHz
Power Setting	High	Modulation	None

CENTER FREQ 154.0998 MHz
 SPAN 50 KHz

 REF LEVEL 46.3 dBm
 /DIV 10 dB/
 ATT 20 dB
 OFFSET 34 dB

 RES BW 100 Hz
 VIDEO BW 100 Hz

 SWEEP TIME 30 s
 AVG

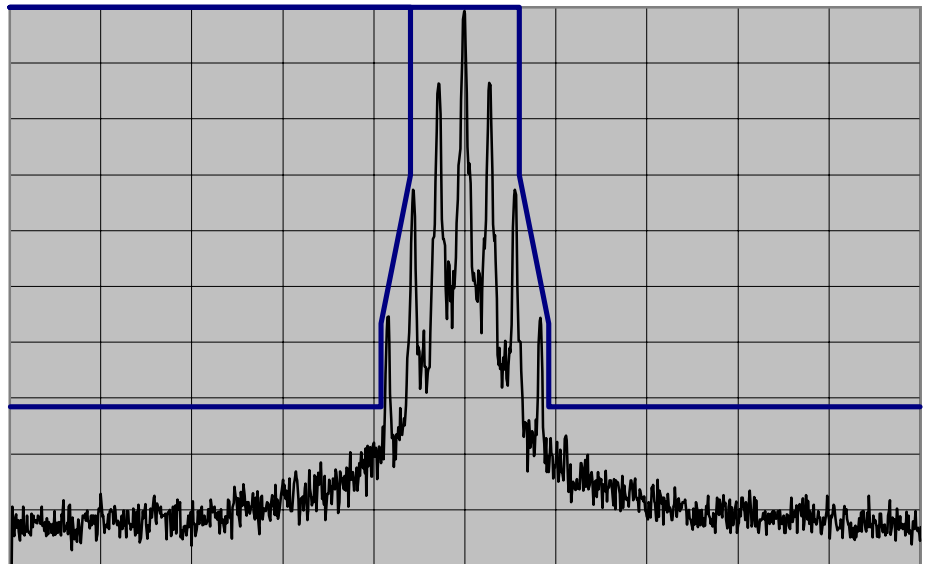

Model Name	VX-7200-D0-50	Transmit Frequency	154.1 MHz
Serial Number	4L000008	Channel Spacing	6.25 kHz
Power Setting	High	Modulation	Voice

Occupied Bandwidth

CENTER FREQ 173.9998 MHz
 SPAN 50 KHz
 REF LEVEL 46.3 dBm
 /DIV 10 dB/
 ATT 20 dB
 OFFSET 34 dB
 RES BW 100 Hz
 VIDEO BW 100 Hz
 SWEEP TIME 30 s
 AVG

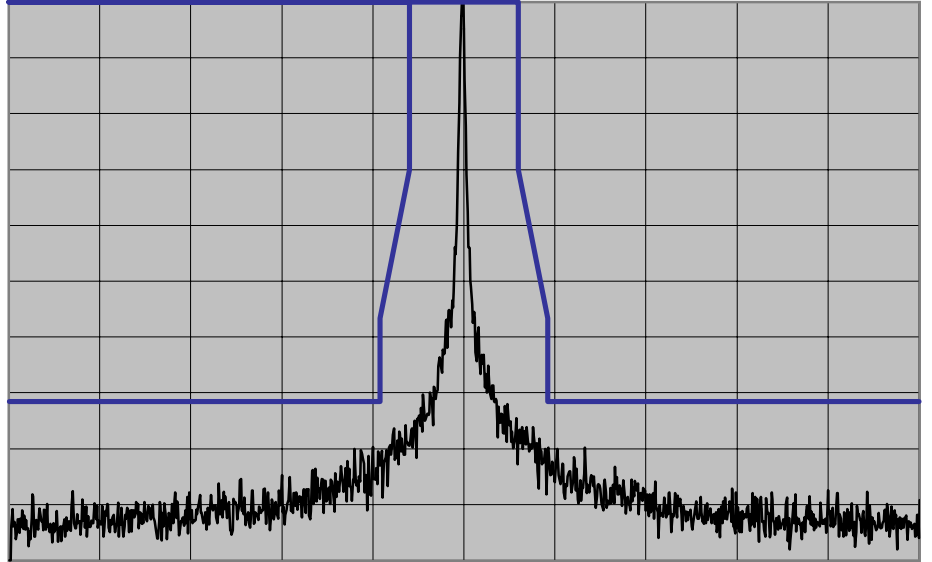

Model Name	VX-7200-D0-50	Transmit Frequency	174 MHz
Serial Number	4L000008	Channel Spacing	6.25 kHz
Power Setting	High	Modulation	None

CENTER FREQ 173.9998 MHz
 SPAN 50 KHz
 REF LEVEL 46.3 dBm
 /DIV 10 dB/
 ATT 20 dB
 OFFSET 34 dB
 RES BW 100 Hz
 VIDEO BW 100 Hz
 SWEEP TIME 30 s
 AVG

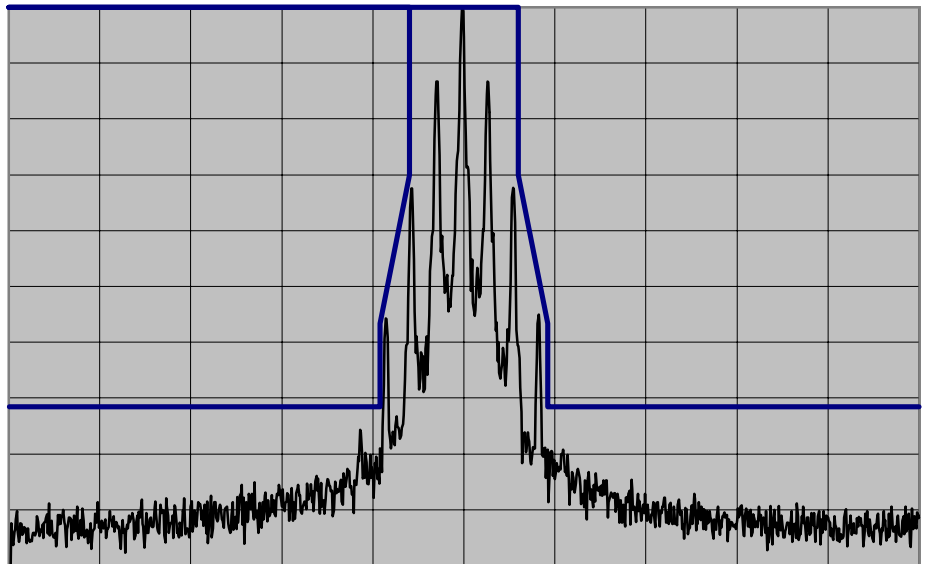

Model Name	VX-7200-D0-50	Transmit Frequency	174 MHz
Serial Number	4L000008	Channel Spacing	6.25 kHz
Power Setting	High	Modulation	Voice

Occupied Bandwidth

CENTER FREQ 133.9999 MHz
 SPAN 50 KHz
 REF LEVEL 45.4 dBm
 /DIV 10 dB/
 ATT 20 dB
 OFFSET 34 dB
 RES BW 100 Hz
 VIDEO BW 100 Hz
 SWEEP TIME 30 s
 AVG

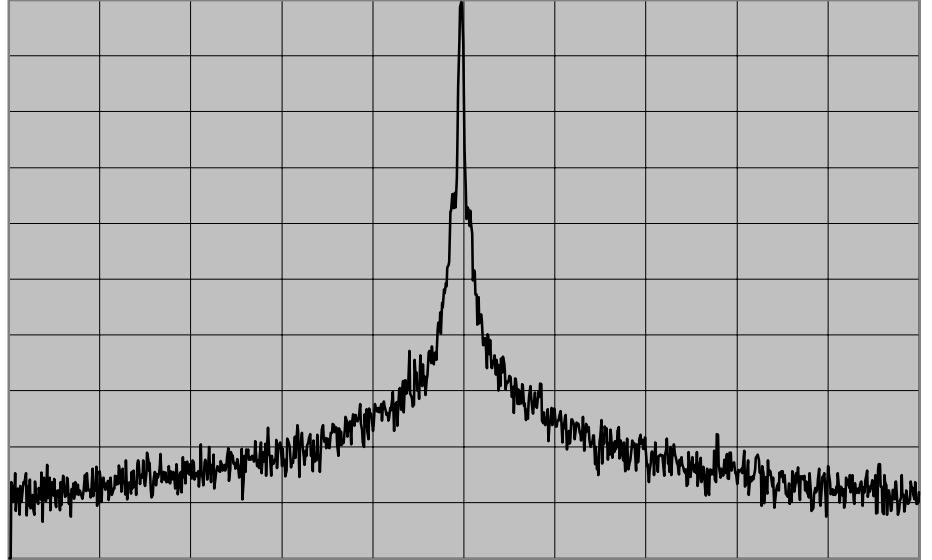

Model Name	VX-7200-D0-50	Transmit Frequency	134 MHz
Serial Number	4L000008	Channel Spacing	12.5 kHz
Power Setting	High	Modulation	None

CENTER FREQ 133.999 MHz
 SPAN 50 KHz
 REF LEVEL 45.4 dBm
 /DIV 10 dB/
 ATT 20 dB
 OFFSET 34 dB
 RES BW 100 Hz
 VIDEO BW 100 Hz
 SWEEP TIME 30 s
 AVG

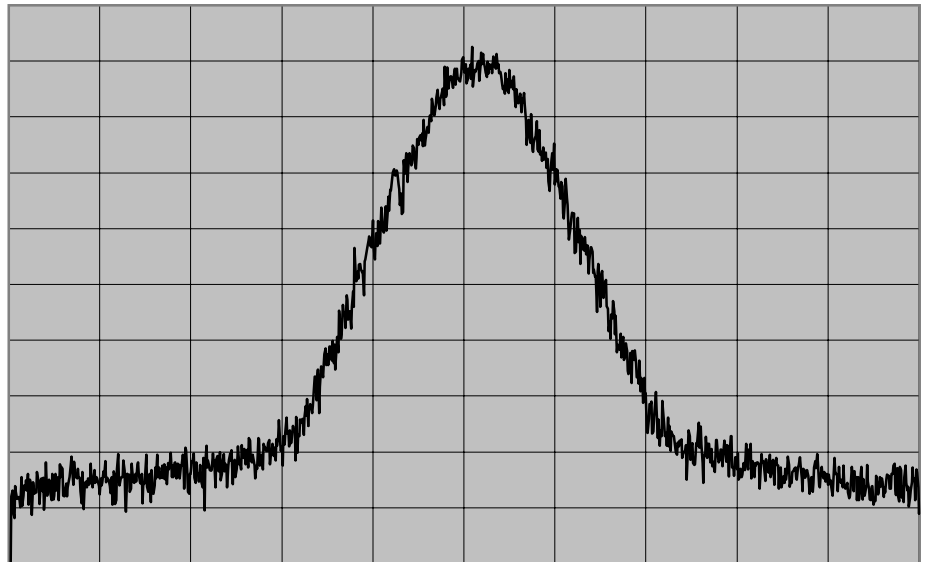

Model Name	VX-7200-D0-50	Transmit Frequency	134 MHz
Serial Number	4L000008	Channel Spacing	12.5 kHz
Power Setting	High	Modulation	Voice-Digital

Occupied Bandwidth

CENTER FREQ 154.0998 MHz
 SPAN 50 KHz
 REF LEVEL 46 dBm
 /DIV 10 dB/
 ATT 20 dB
 OFFSET 34 dB
 RES BW 100 Hz
 VIDEO BW 100 Hz
 SWEEP TIME 30 s
 AVG

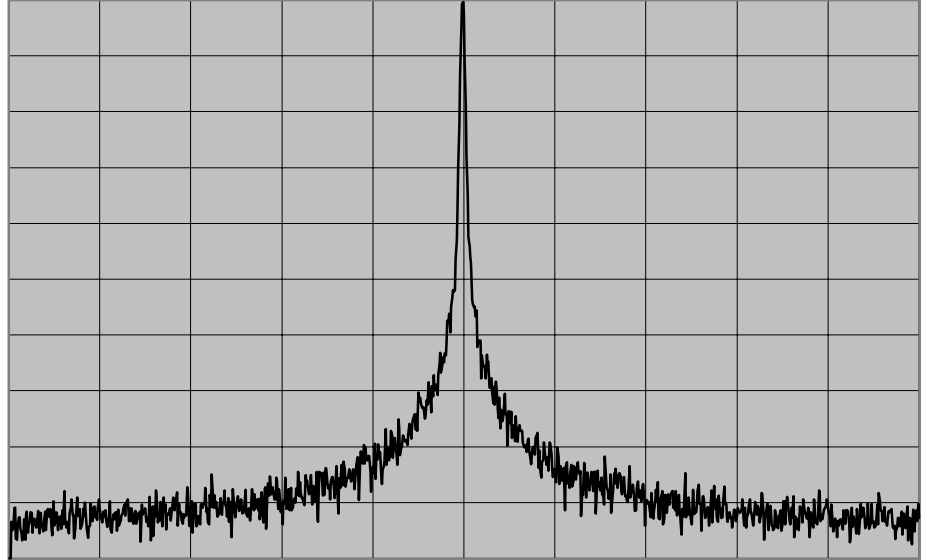

Model Name	VX-7200-D0-50	Transmit Frequency	154.1 MHz
Serial Number	4L000008	Channel Spacing	12.5 kHz
Power Setting	High	Modulation	None

CENTER FREQ 154.0999 MHz
 SPAN 50 KHz
 REF LEVEL 46 dBm
 /DIV 10 dB/
 ATT 20 dB
 OFFSET 34 dB
 RES BW 100 Hz
 VIDEO BW 100 Hz
 SWEEP TIME 30 s
 AVG

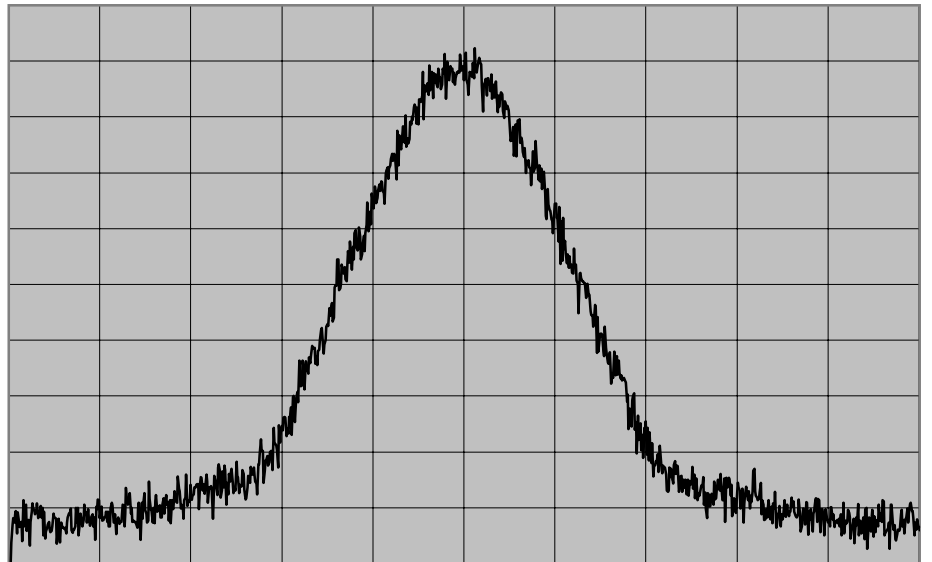

Model Name	VX-7200-D0-50	Transmit Frequency	154.1 MHz
Serial Number	4L000008	Channel Spacing	12.5 kHz
Power Setting	High	Modulation	Voice-Digital

Occupied Bandwidth

CENTER FREQ 173.9998 MHz
 SPAN 50 KHz
 REF LEVEL 46.3 dBm
 /DIV 10 dB/
 ATT 20 dB
 OFFSET 34 dB
 RES BW 100 Hz
 VIDEO BW 100 Hz
 SWEEP TIME 30 s
 AVG

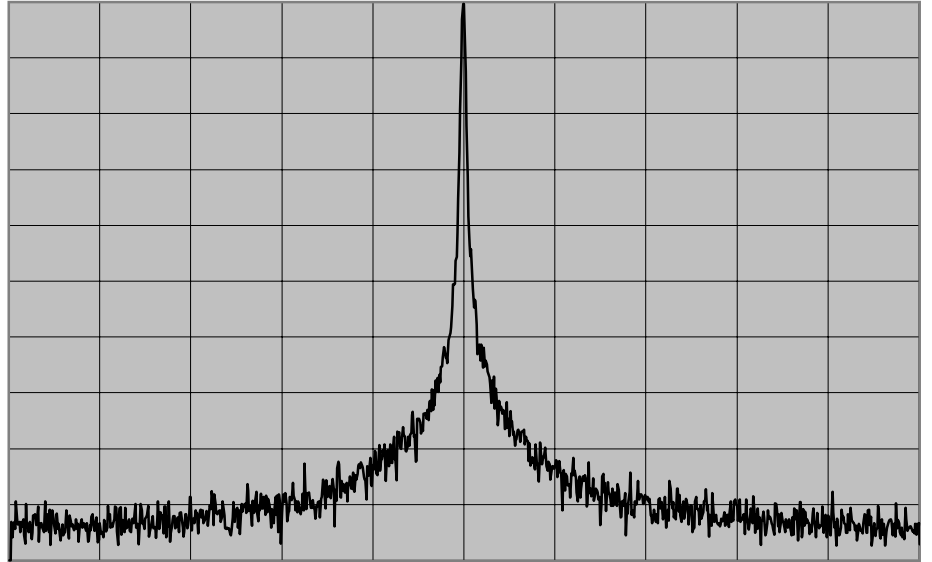

Model Name	VX-7200-D0-50	Transmit Frequency	174 MHz
Serial Number	4L000008	Channel Spacing	12.5 kHz
Power Setting	High	Modulation	None

CENTER FREQ 173.9997 MHz
 SPAN 50 KHz
 REF LEVEL 46.3 dBm
 /DIV 10 dB/
 ATT 20 dB
 OFFSET 34 dB
 RES BW 100 Hz
 VIDEO BW 100 Hz
 SWEEP TIME 30 s
 AVG

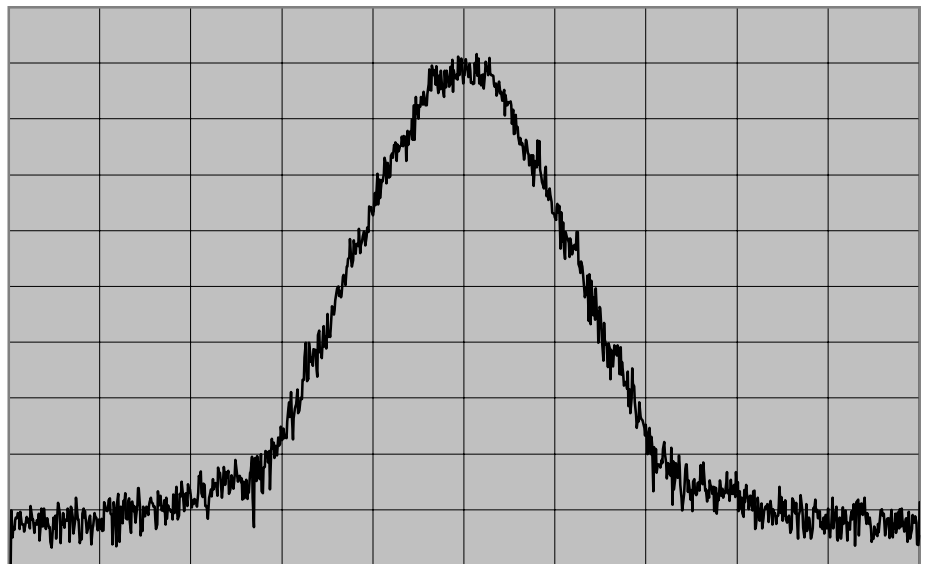

Model Name	VX-7200-D0-50	Transmit Frequency	174 MHz
Serial Number	4L000008	Channel Spacing	12.5 kHz
Power Setting	High	Modulation	Voice-Digital

Transient Frequency Behavior of the Transmitter

Model Name: VX-7200-D0-50
Serial Number: 4L000008

Test Frequency: 134 [MHz]
Channel Spacing: 25 [kHz]
Transmitter Type: Mobile/Portable
Trigger Direction: Rise

Ref. Standard: EIA

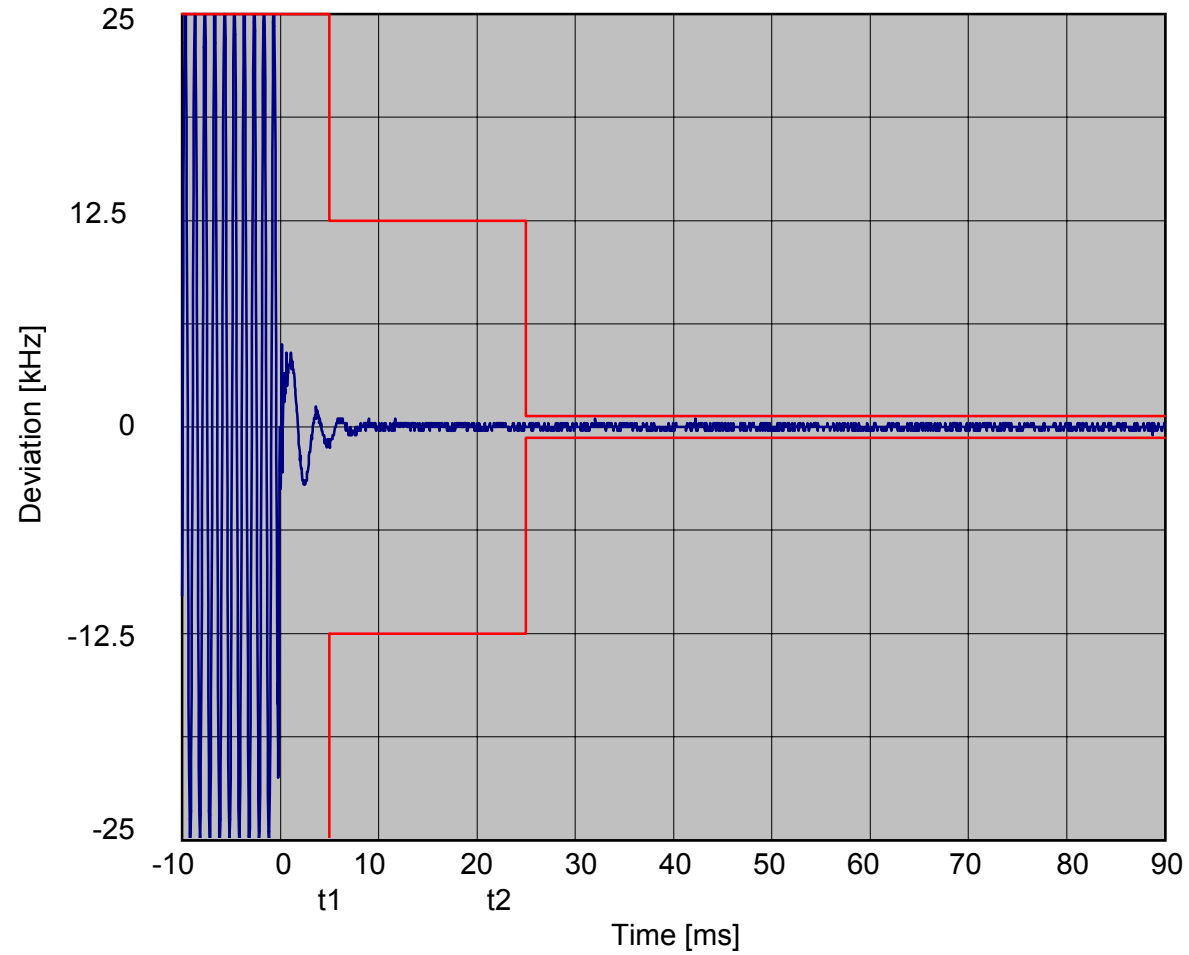

Transient Frequency Behavior of the Transmitter

Model Name: VX-7200-D0-50
Serial Number: 4L000008

Test Frequency: 134 [MHz]
Channel Spacing: 25 [kHz]
Transmitter Type: Mobile/Portable
Trigger Direction: Fall

Ref. Standard: EIA

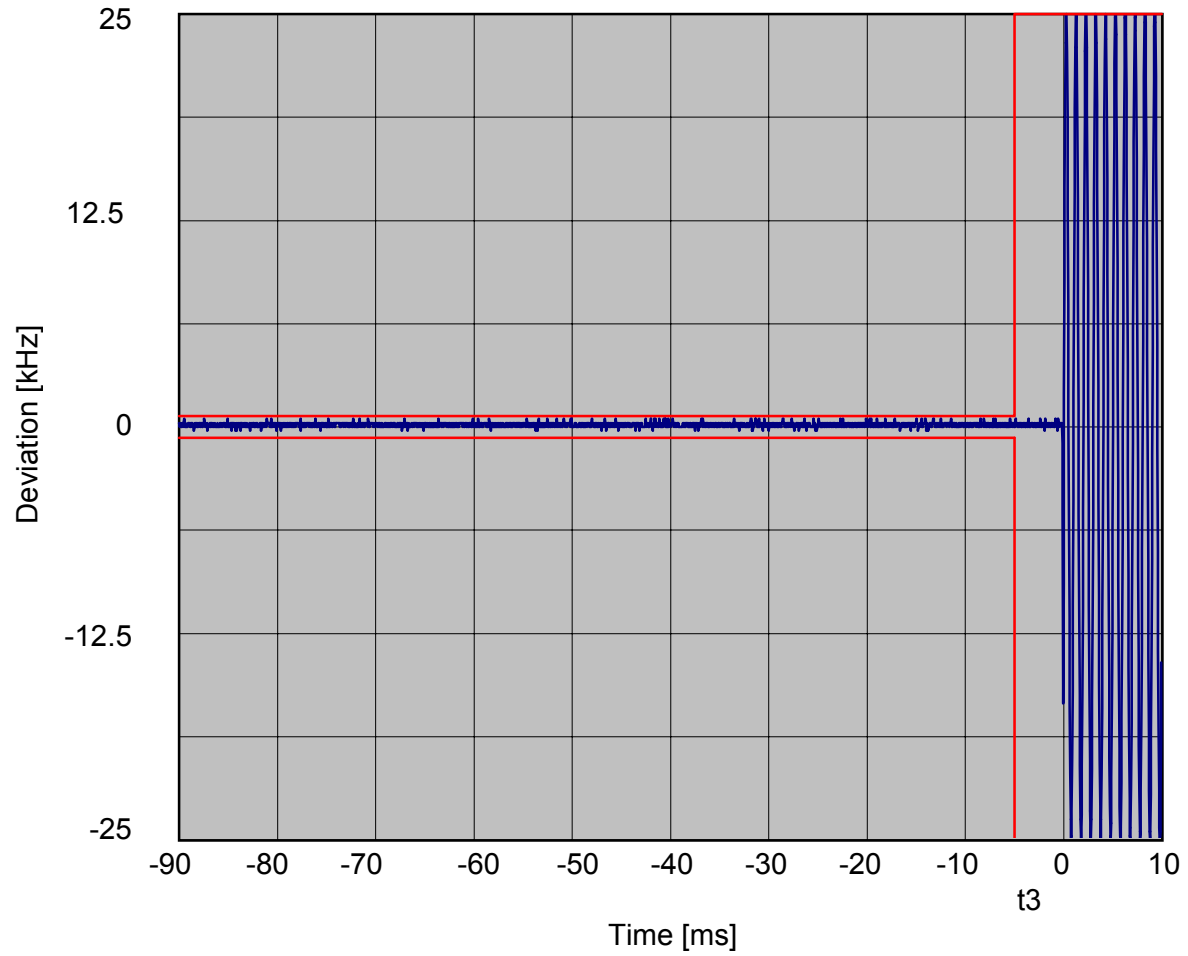

Transient Frequency Behavior of the Transmitter

Model Name: VX-7200-D0-50
Serial Number: 4L000008

Test Frequency: 154.1 [MHz]
Channel Spacing: 25 [kHz]
Transmitter Type: Mobile/Portable
Trigger Direction: Rise

Ref. Standard: EIA

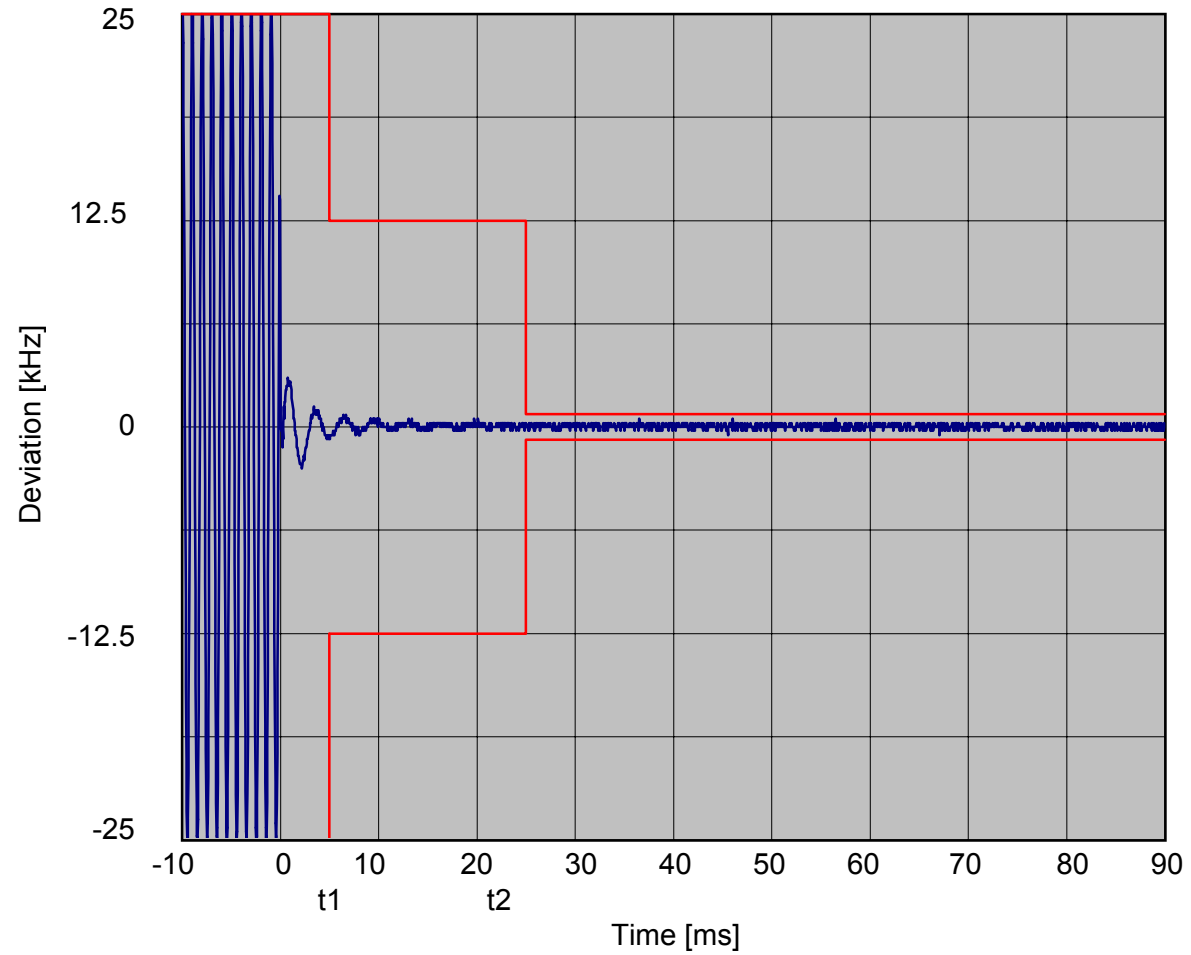

Transient Frequency Behavior of the Transmitter

Model Name: VX-7200-D0-50
Serial Number: 4L000008

Test Frequency: 154.1 [MHz]
Channel Spacing: 25 [kHz]
Transmitter Type: Mobile/Portable
Trigger Direction: Fall

Ref. Standard: EIA

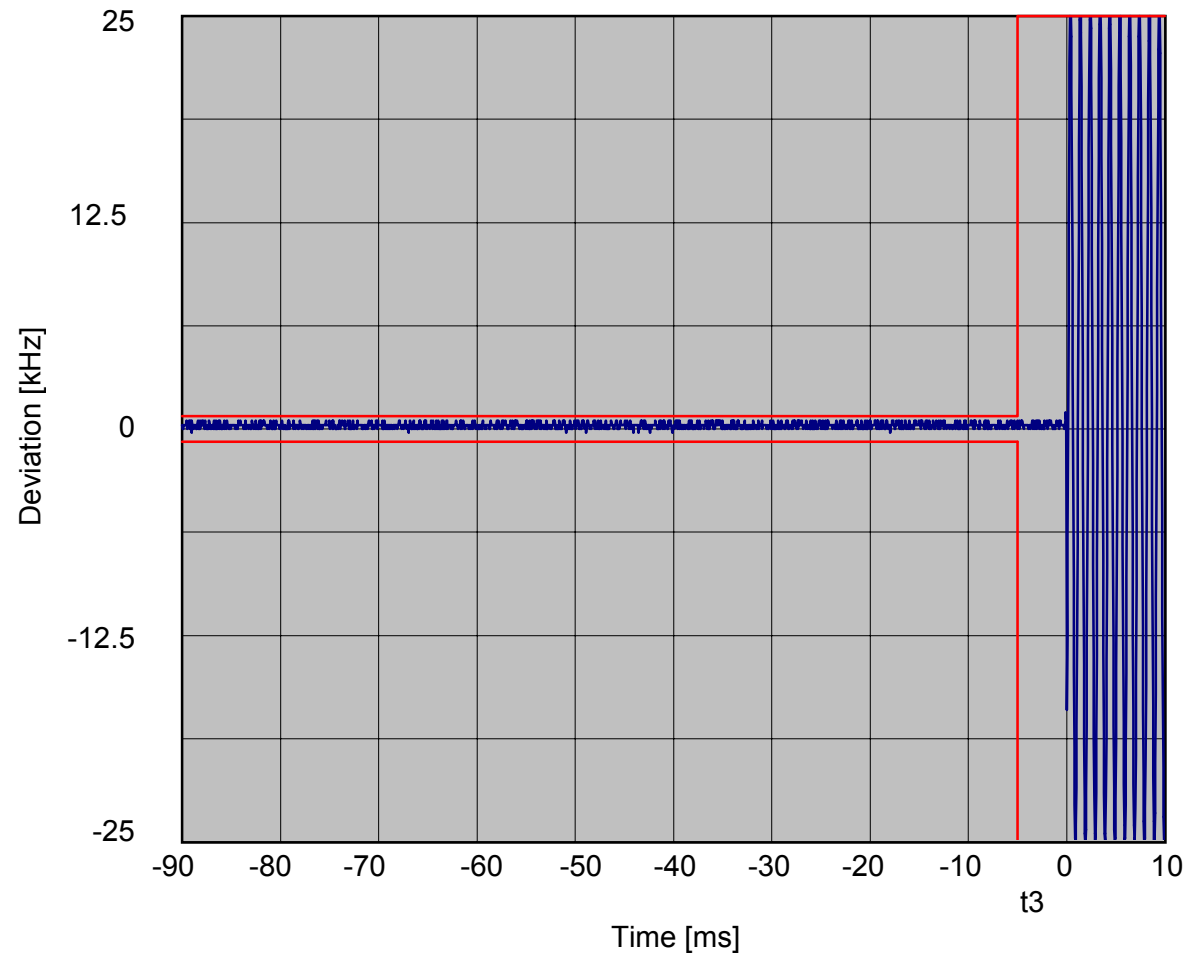

Transient Frequency Behavior of the Transmitter

Model Name: VX-7200-D0-50
Serial Number: 4L000008

Test Frequency: 174 [MHz]
Channel Spacing: 25 [kHz]
Transmitter Type: Mobile/Portable
Trigger Direction: Rise

Ref. Standard: EIA

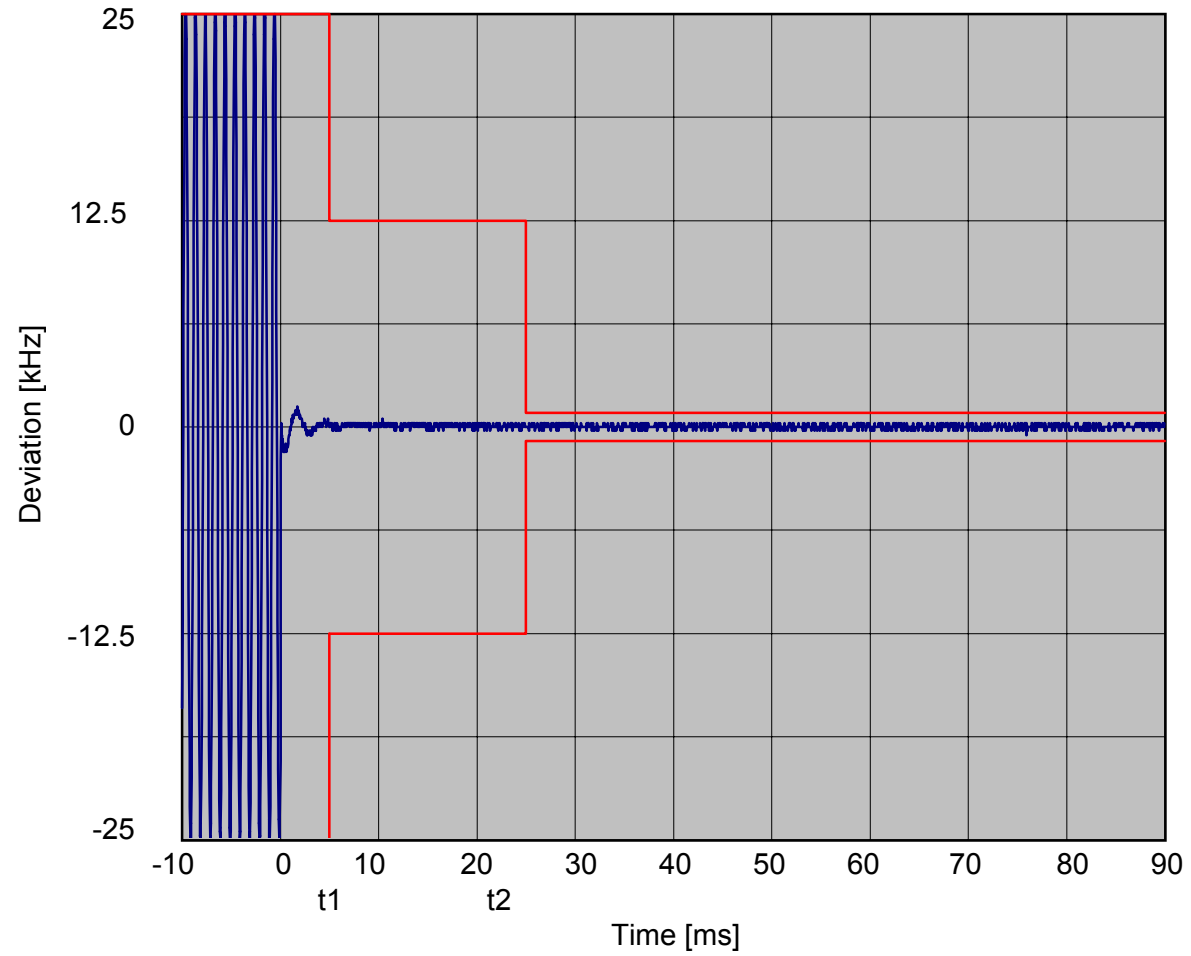

Transient Frequency Behavior of the Transmitter

Model Name: VX-7200-D0-50
Serial Number: 4L000008

Test Frequency: 174 [MHz]
Channel Spacing: 25 [kHz]
Transmitter Type: Mobile/Portable
Trigger Direction: Fall

Ref. Standard: EIA

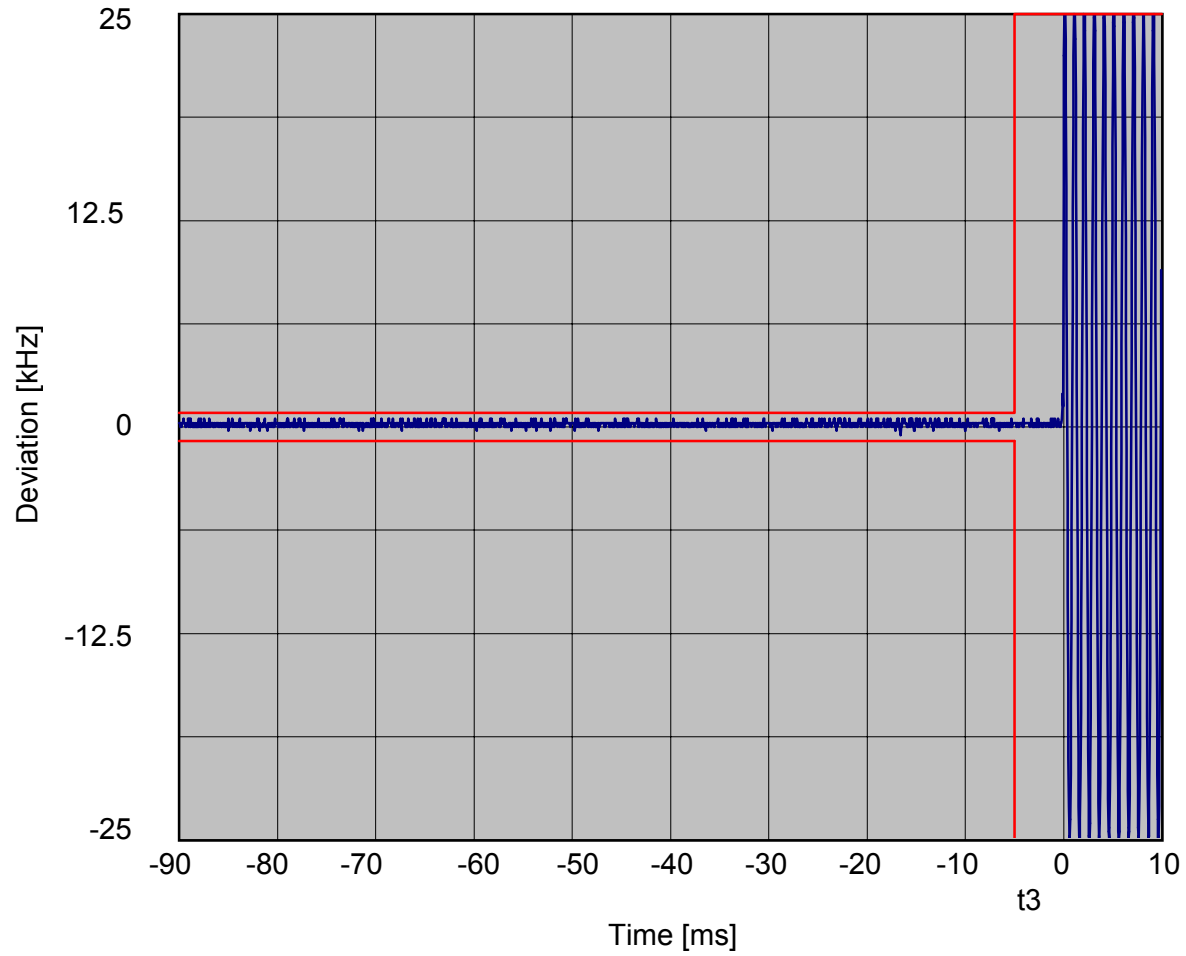

Transient Frequency Behavior of the Transmitter

Model Name: VX-7200-D0-50
Serial Number: 4L000008
Test Frequency: 134 [MHz]
Channel Spacing: 12.5 [kHz]
Transmitter Type: Mobile/Portable
Trigger Direction: Rise
Ref. Standard: EIA

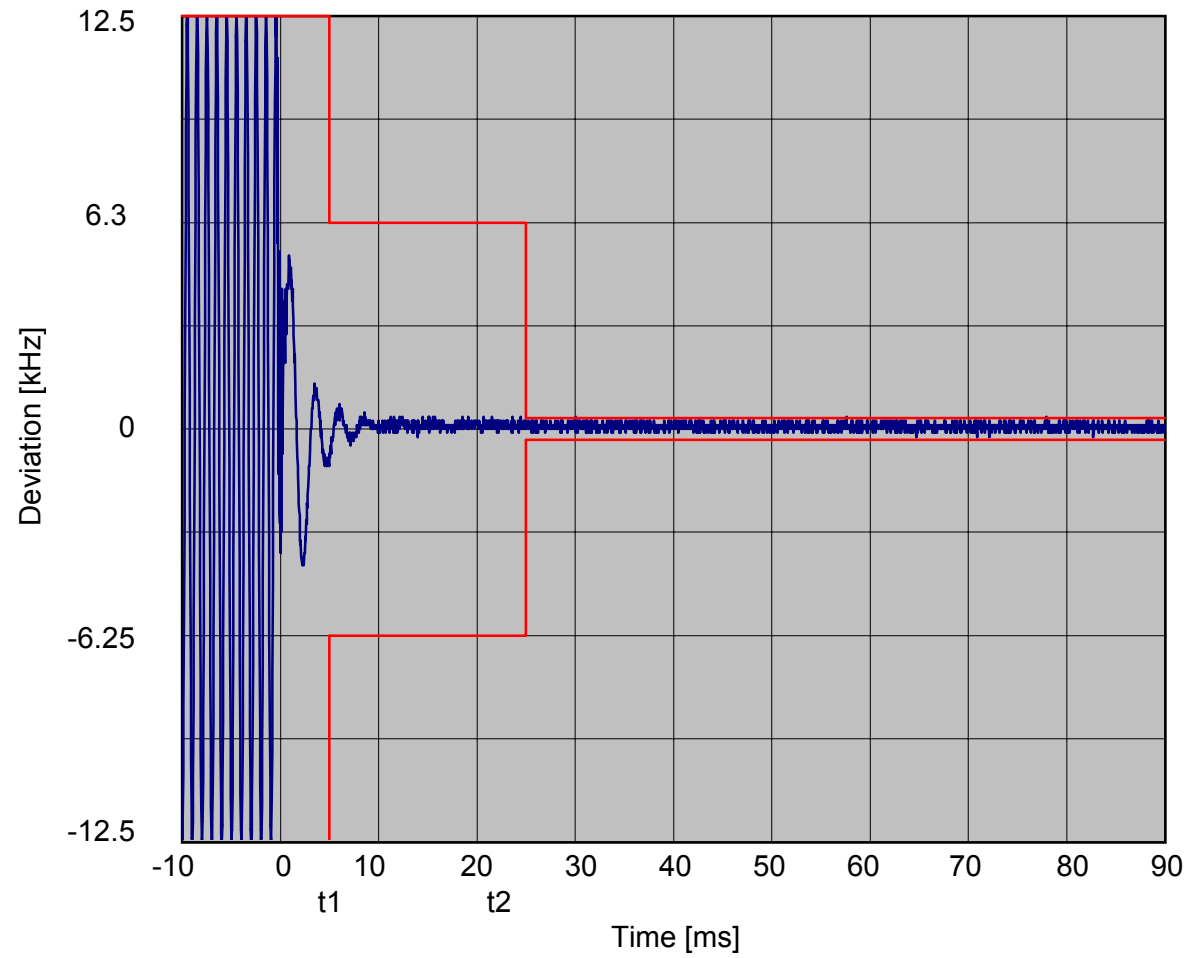

Transient Frequency Behavior of the Transmitter

Model Name: VX-7200-D0-50
Serial Number: 4L000008
Test Frequency: 134 [MHz]
Channel Spacing: 12.5 [kHz]
Transmitter Type: Mobile/Portable
Trigger Direction: Fall
Ref. Standard: EIA

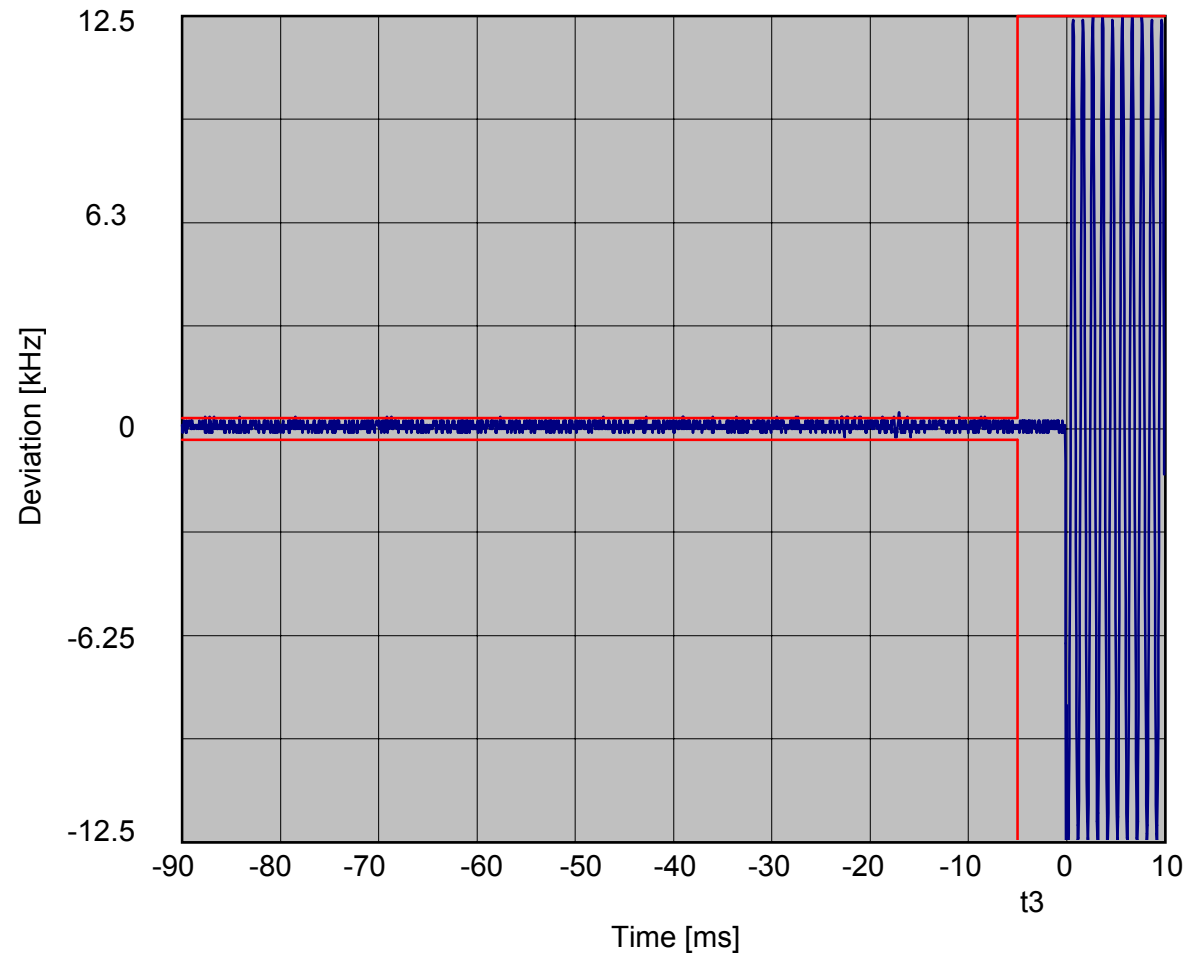

Transient Frequency Behavior of the Transmitter

Model Name: VX-7200-D0-50
Serial Number: 4L000008

Test Frequency: 154.1 [MHz]
Channel Spacing: 12.5 [kHz]
Transmitter Type: Mobile/Portable
Trigger Direction: Rise

Ref. Standard: EIA

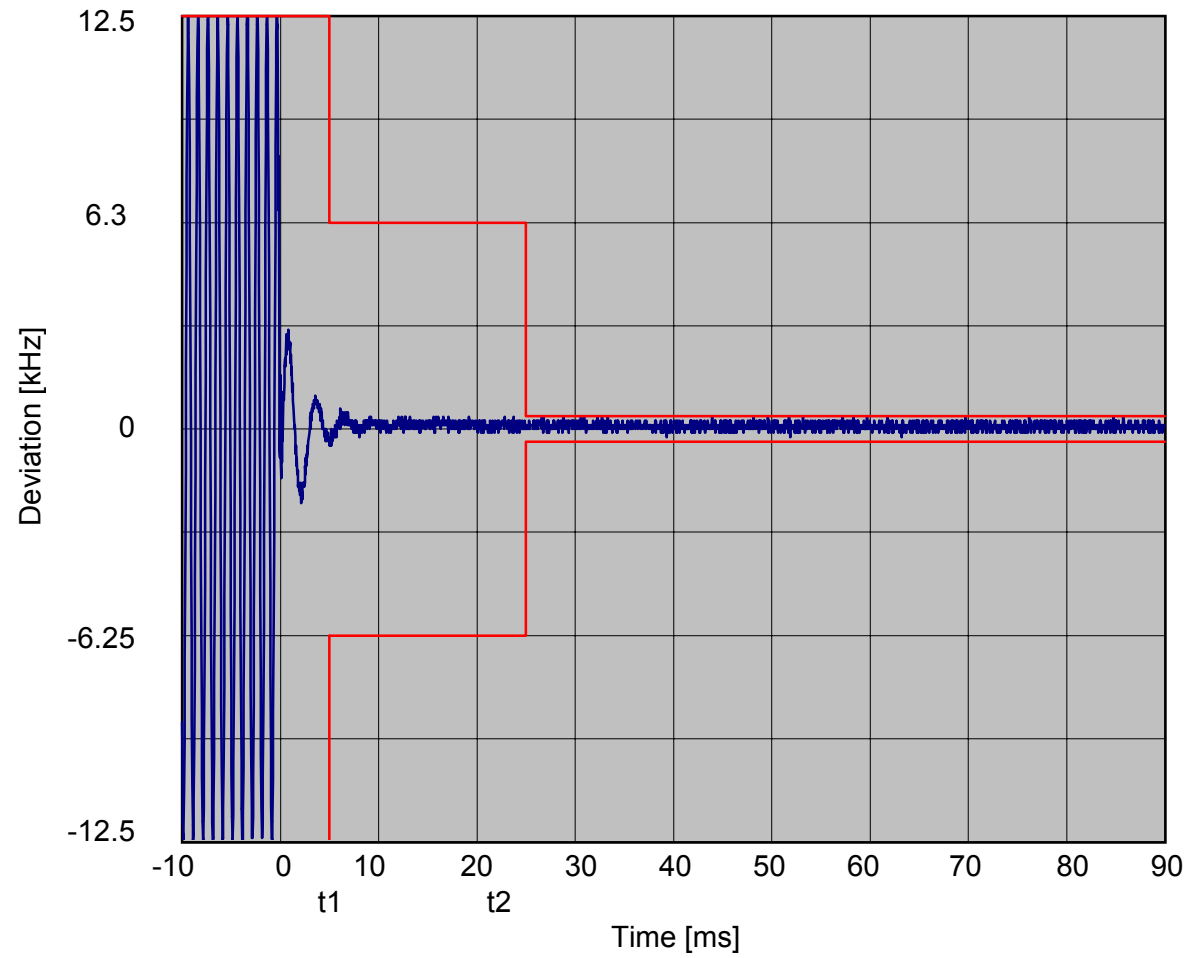

Transient Frequency Behavior of the Transmitter

Model Name: VX-7200-D0-50
Serial Number: 4L000008

Test Frequency: 154.1 [MHz]
Channel Spacing: 12.5 [kHz]
Transmitter Type: Mobile/Portable
Trigger Direction: Fall

Ref. Standard: EIA

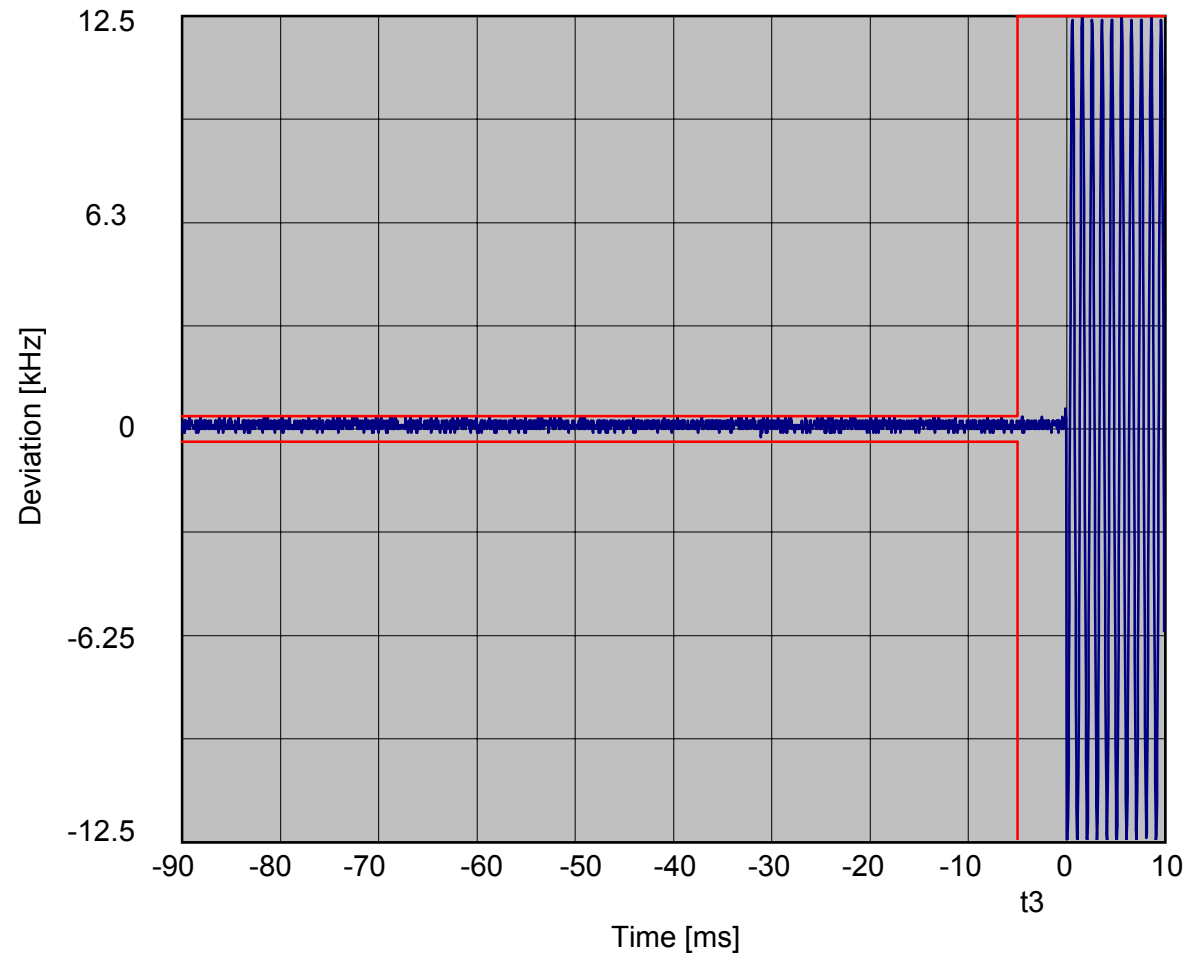

Transient Frequency Behavior of the Transmitter

Model Name: VX-7200-D0-50
Serial Number: 4L000008

Test Frequency: 174 [MHz]
Channel Spacing: 12.5 [kHz]
Transmitter Type: Mobile/Portable
Trigger Direction: Rise

Ref. Standard: EIA

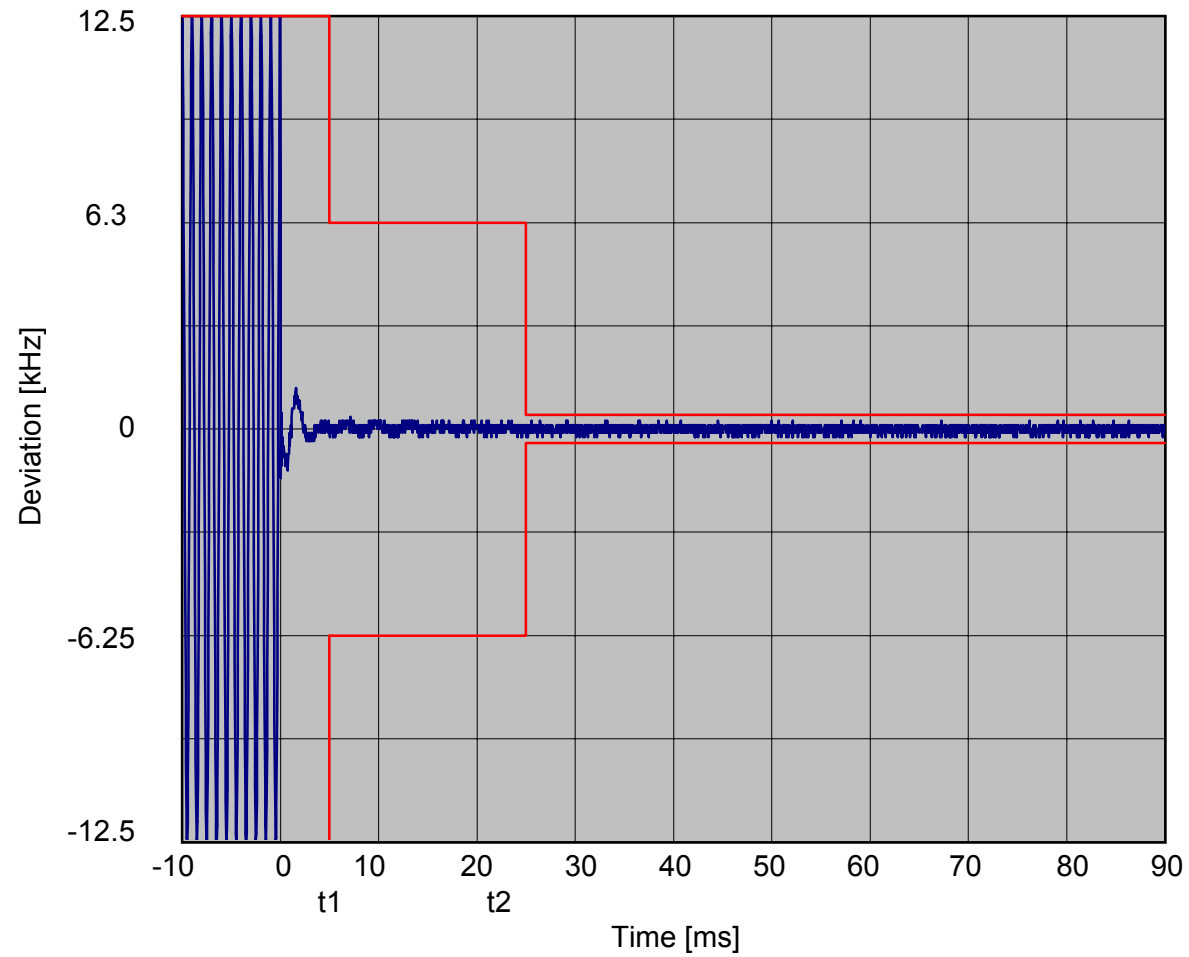

Transient Frequency Behavior of the Transmitter

Model Name: VX-7200-D0-50
Serial Number: 4L000008

Test Frequency: 174 [MHz]
Channel Spacing: 12.5 [kHz]
Transmitter Type: Mobile/Portable
Trigger Direction: Fall

Ref. Standard: EIA

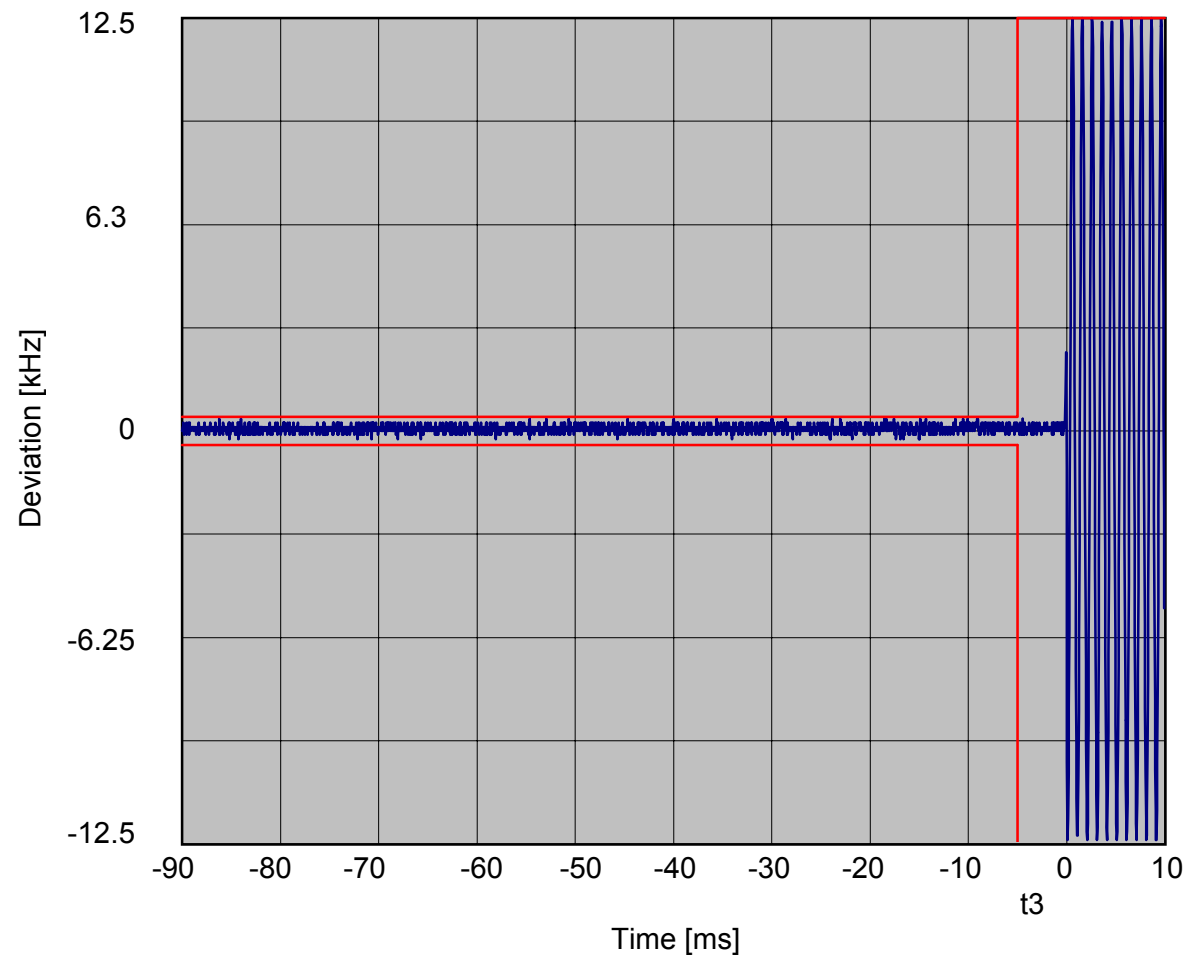

Transient Frequency Behavior of the Transmitter

Model Name: VX-7200-D0-50
Serial Number: 4L000008

Test Frequency: 134 [MHz]
Channel Spacing: 6.25 [kHz]
Transmitter Type: Mobile/Portable
Trigger Direction: Rise

Ref. Standard: EIA

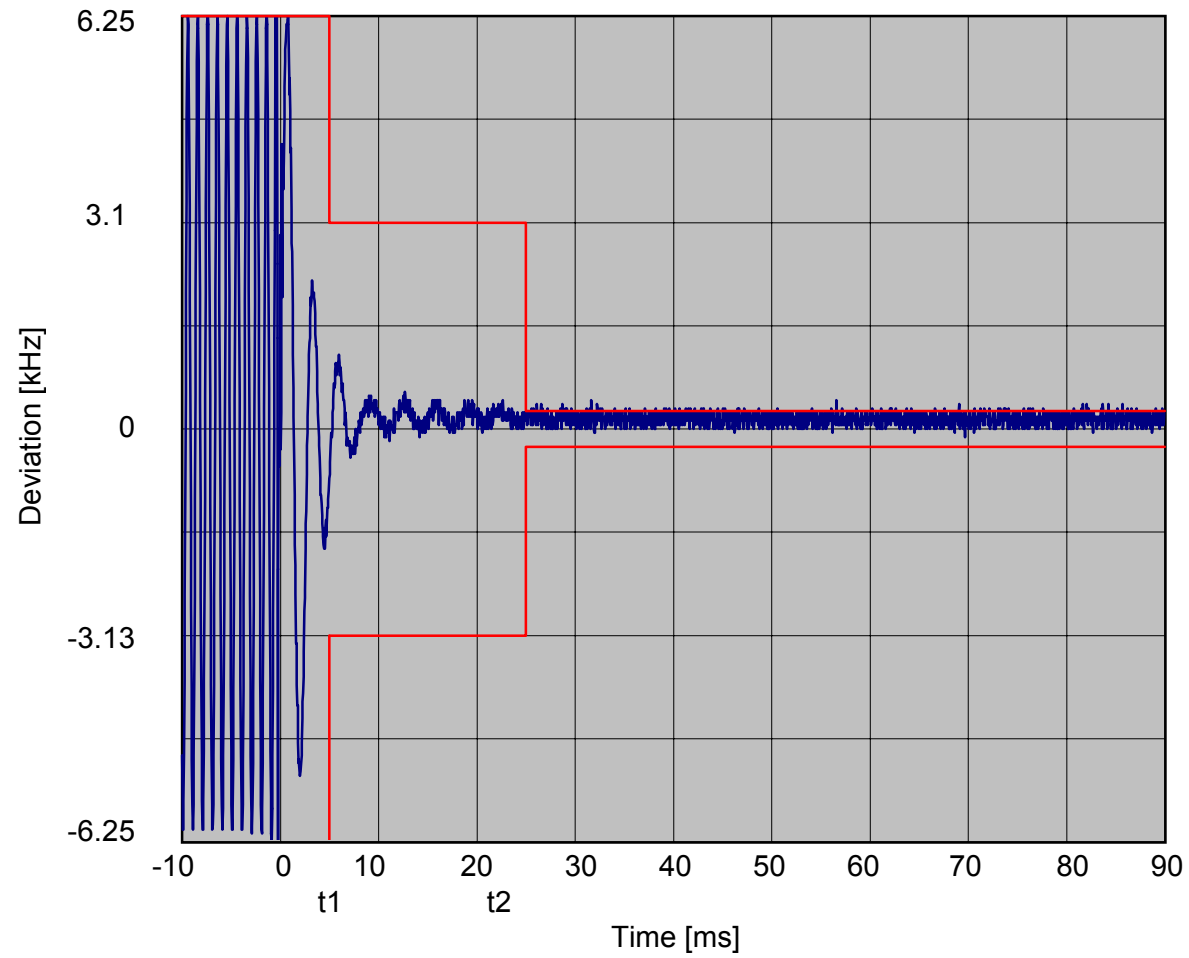

Transient Frequency Behavior of the Transmitter

Model Name: VX-7200-D0-50
Serial Number: 4L000008

Test Frequency: 134 [MHz]
Channel Spacing: 6.25 [kHz]
Transmitter Type: Mobile/Portable
Trigger Direction: Fall

Ref. Standard: EIA

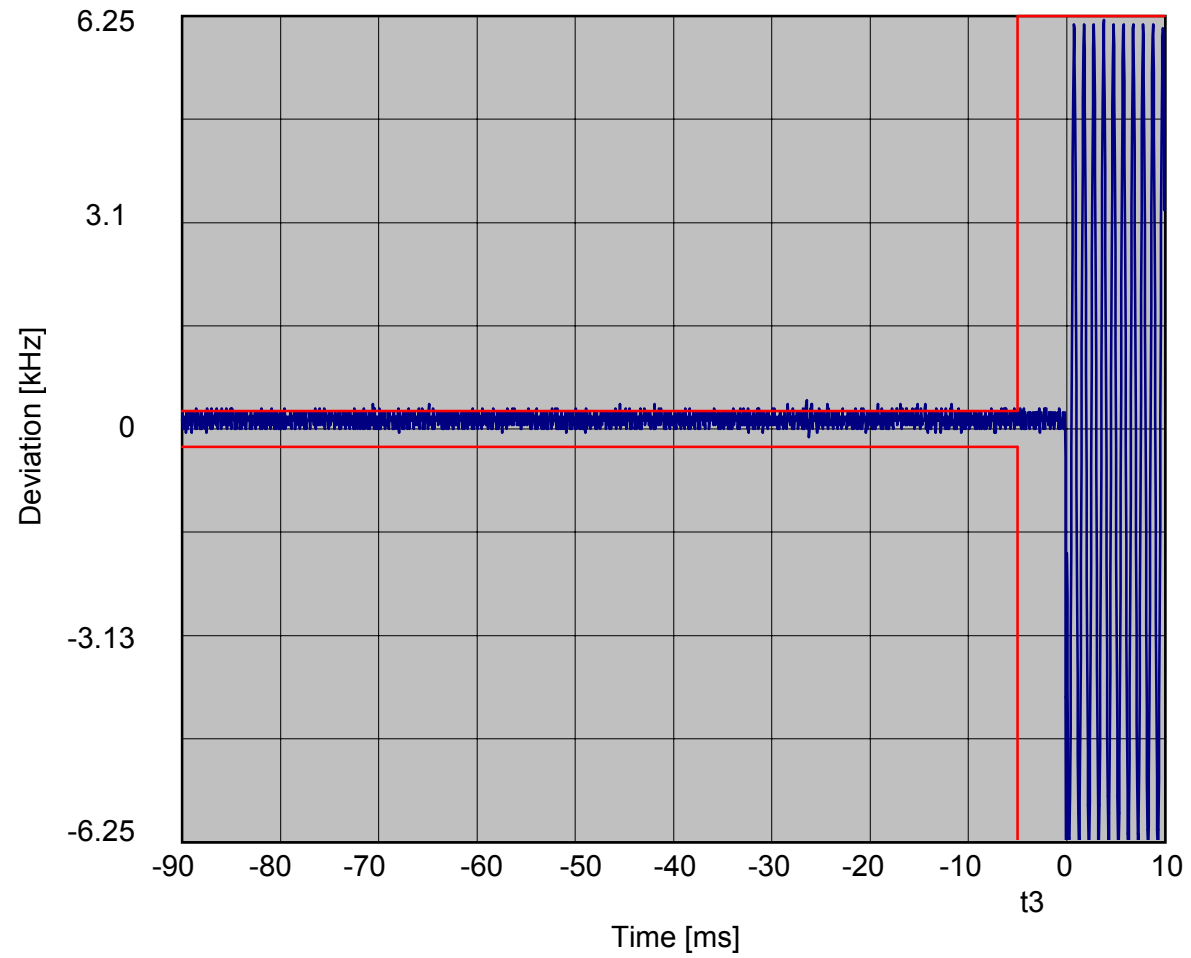

Transient Frequency Behavior of the Transmitter

Model Name: VX-7200-D0-50
Serial Number: 4L000008

Test Frequency: 154.1 [MHz]
Channel Spacing: 6.25 [kHz]
Transmitter Type: Mobile/Portable
Trigger Direction: Rise

Ref. Standard: EIA

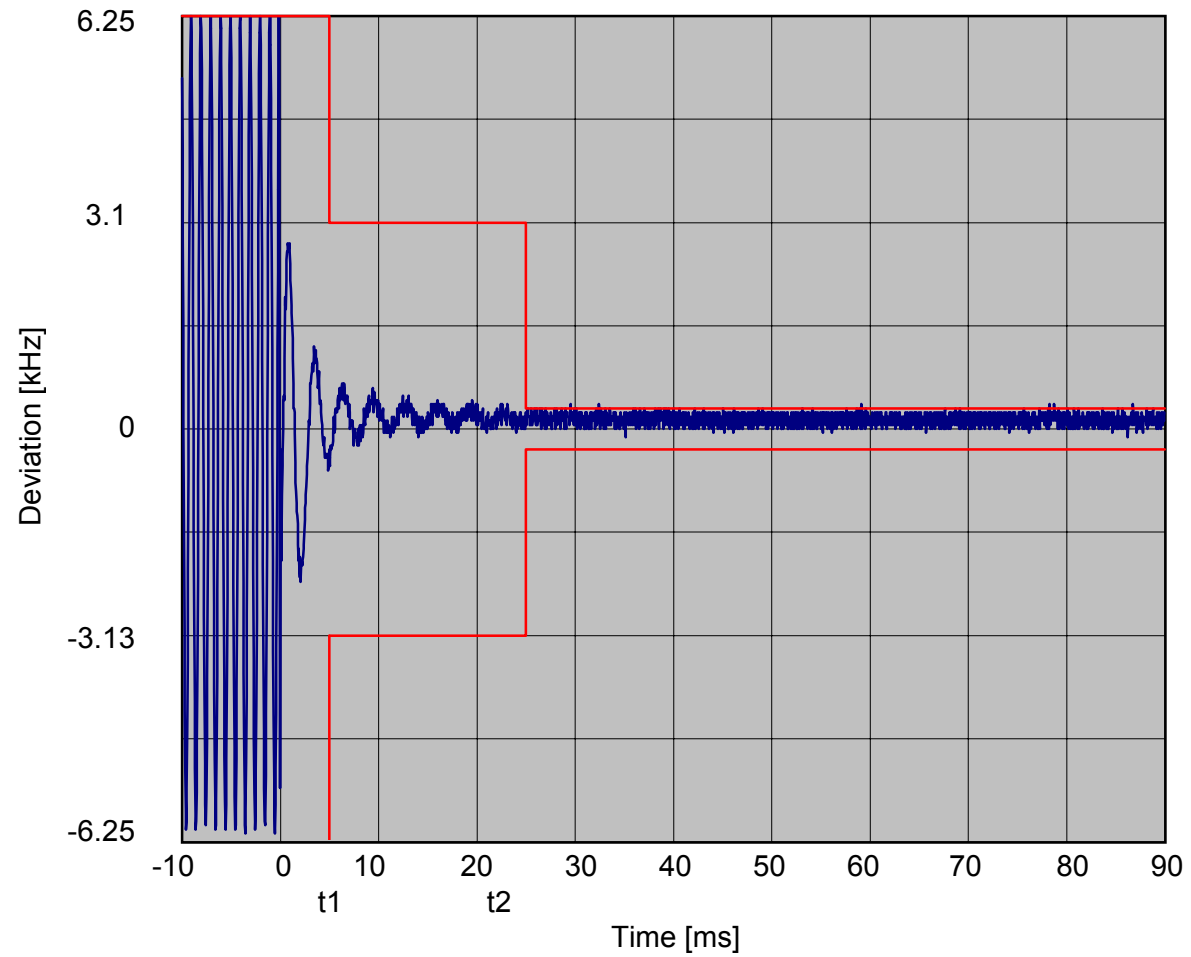

Transient Frequency Behavior of the Transmitter

Model Name: VX-7200-D0-50
Serial Number: 4L000008

Test Frequency: 154.1 [MHz]
Channel Spacing: 6.25 [kHz]
Transmitter Type: Mobile/Portable
Trigger Direction: Fall

Ref. Standard: EIA

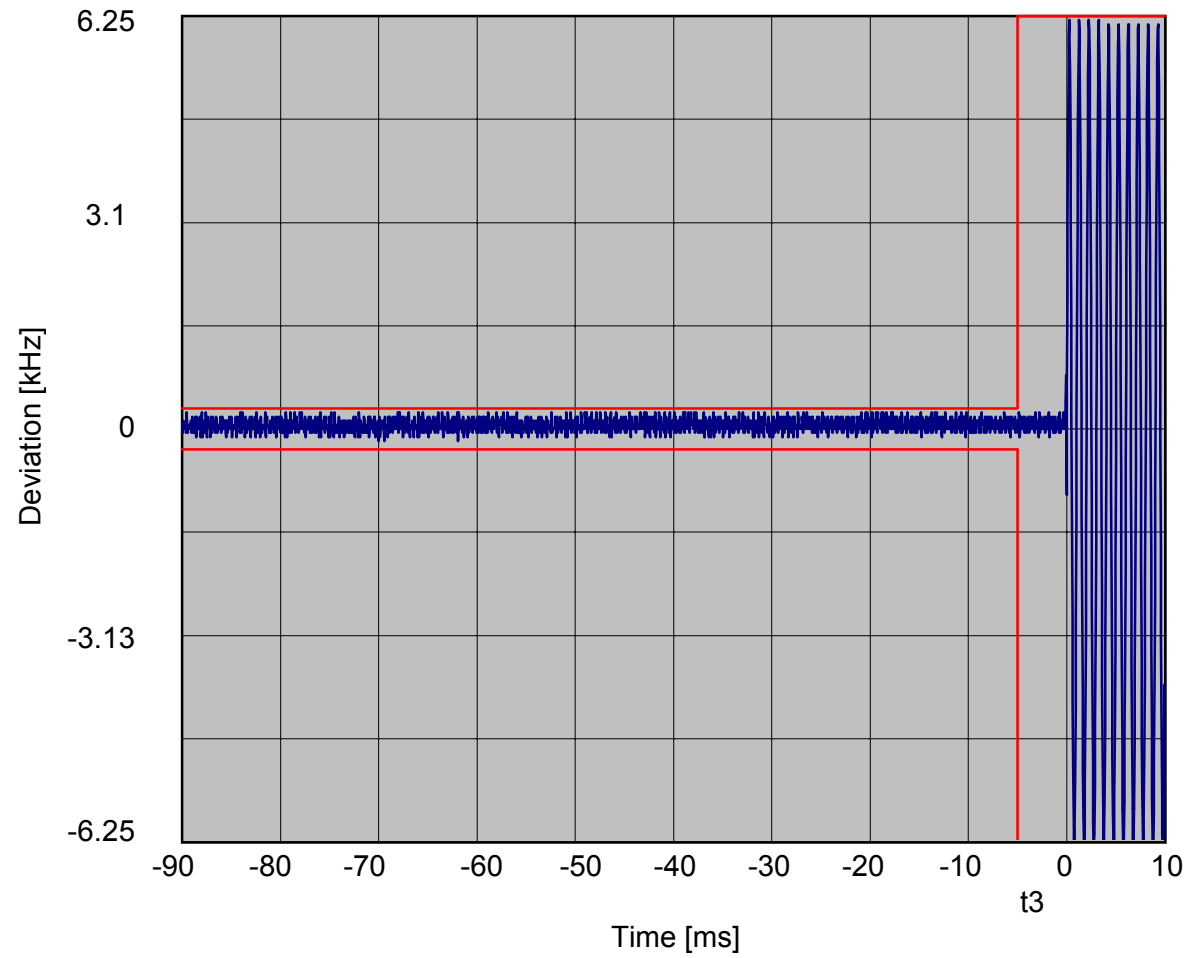

Transient Frequency Behavior of the Transmitter

Model Name: VX-7200-D0-50
Serial Number: 4L000008

Test Frequency: 174 [MHz]
Channel Spacing: 6.25 [kHz]
Transmitter Type: Mobile/Portable
Trigger Direction: Rise

Ref. Standard: EIA

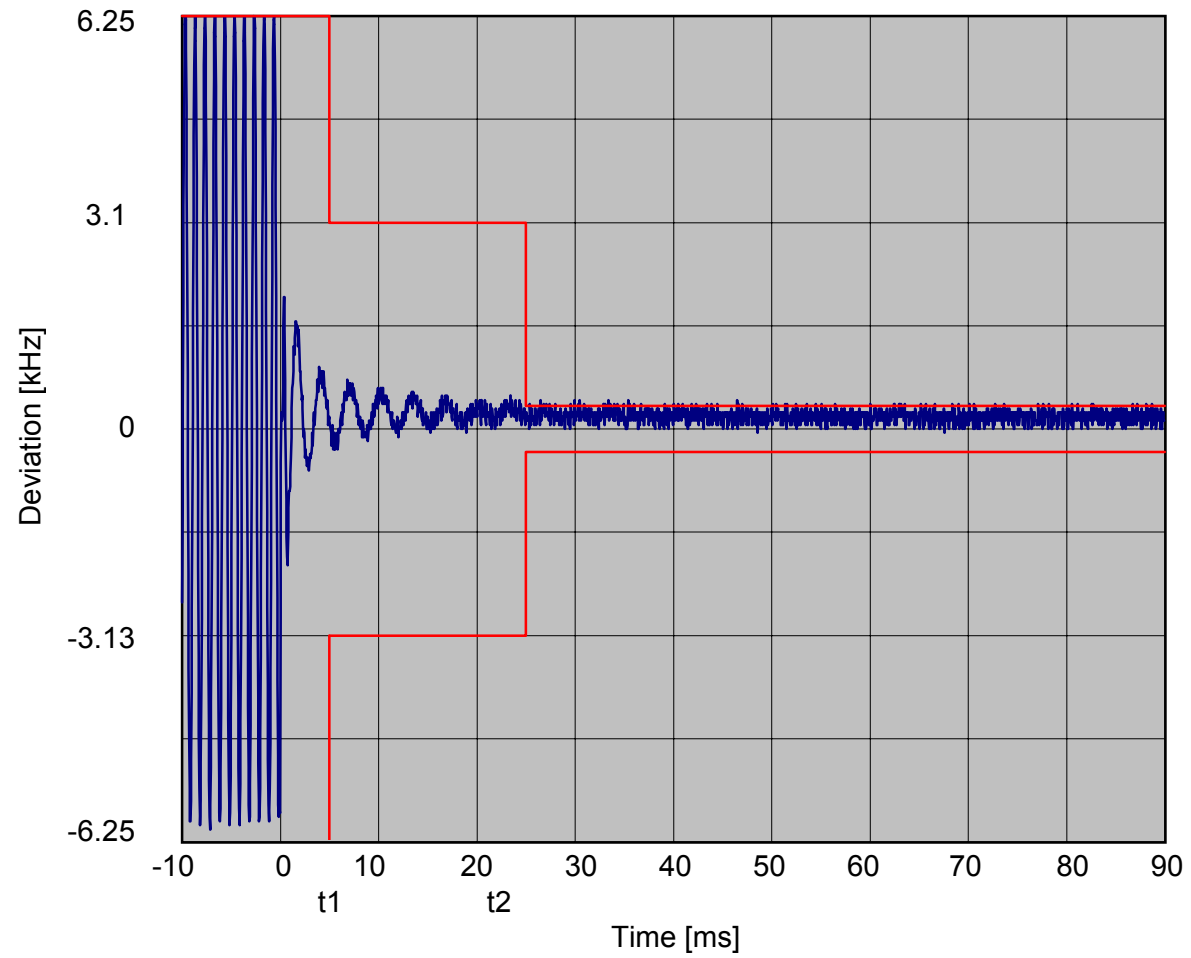

Transient Frequency Behavior of the Transmitter

Model Name: VX-7200-D0-50
Serial Number: 4L000008
Test Frequency: 174 [MHz]
Channel Spacing: 6.25 [kHz]
Transmitter Type: Mobile/Portable
Trigger Direction: Fall
Ref. Standard: EIA

