

## DECLARATION OF COMPLIANCE SAR RF EXPOSURE EVALUATION

<p><b><u>Test Lab</u></b></p> <p><b>CELLTECH LABS INC.</b> Testing and Engineering Services 1955 Moss Court Kelowna, B.C. Canada V1Y 9L3 Phone: 250-448-7047 Fax: 250-448-7046 e-mail: info@celltechlabs.com web site: www.celltechlabs.com</p>	<p><b><u>Applicant Information</u></b></p> <p><b>VERTEX STANDARD CO., LTD.</b> 4-8-8, Nakameguro, Meguro-Ku Tokyo 153-8644 Japan</p>																										
<table style="width: 100%; border-collapse: collapse;"> <tr> <td style="width: 35%;"><b>Rule Part(s):</b></td> <td>FCC 47 CFR §2.1093; IC RSS-102 Issue 1 (Provisional)</td> </tr> <tr> <td><b>Test Procedure(s):</b></td> <td>FCC OET Bulletin 65, Supplement C (Edition 01-01)</td> </tr> <tr> <td><b>Device Classification:</b></td> <td>Licensed Non-Broadcast Transmitter Held to Face (TNF)</td> </tr> <tr> <td><b>Device Type:</b></td> <td>Portable FM VHF PTT Radio Transceiver</td> </tr> <tr> <td><b>FCC ID:</b></td> <td>K6610503220</td> </tr> <tr> <td><b>Model(s):</b></td> <td>VX-414-2-5 / VX-424-2-5</td> </tr> <tr> <td><b>Modulation:</b></td> <td>FM</td> </tr> <tr> <td><b>Tx Frequency Range:</b></td> <td>146.000 - 174.000 MHz</td> </tr> <tr> <td><b>Max. RF Output Power Tested:</b></td> <td>5.27 Watts Conducted (146.000 MHz) 5.55 Watts Conducted (160.000 MHz) 4.49 Watts Conducted (174.000 MHz)</td> </tr> <tr> <td><b>Antenna Type(s):</b></td> <td>1. Whip 146 MHz (P/N: ATV-8A) 2. Whip 160 MHz (P/N: ATV-8B) 3. Whip 174 MHz (P/N: ATV-8C)</td> </tr> <tr> <td><b>Battery Type(s):</b></td> <td>Nickel-Cadmium (7.2V, 1100mAh)</td> </tr> <tr> <td><b>Body-Worn Accessories Tested:</b></td> <td>1. Belt-Clip (P/N: BA0102700112KA) 2. Speaker-Microphone (P/N: MH-45)</td> </tr> <tr> <td><b>Max. SAR Measured:</b></td> <td>1.44 W/kg - Face-Held (50% Duty Cycle) 2.34 W/kg - Body-Worn (50% Duty Cycle)</td> </tr> </table>		<b>Rule Part(s):</b>	FCC 47 CFR §2.1093; IC RSS-102 Issue 1 (Provisional)	<b>Test Procedure(s):</b>	FCC OET Bulletin 65, Supplement C (Edition 01-01)	<b>Device Classification:</b>	Licensed Non-Broadcast Transmitter Held to Face (TNF)	<b>Device Type:</b>	Portable FM VHF PTT Radio Transceiver	<b>FCC ID:</b>	K6610503220	<b>Model(s):</b>	VX-414-2-5 / VX-424-2-5	<b>Modulation:</b>	FM	<b>Tx Frequency Range:</b>	146.000 - 174.000 MHz	<b>Max. RF Output Power Tested:</b>	5.27 Watts Conducted (146.000 MHz) 5.55 Watts Conducted (160.000 MHz) 4.49 Watts Conducted (174.000 MHz)	<b>Antenna Type(s):</b>	1. Whip 146 MHz (P/N: ATV-8A) 2. Whip 160 MHz (P/N: ATV-8B) 3. Whip 174 MHz (P/N: ATV-8C)	<b>Battery Type(s):</b>	Nickel-Cadmium (7.2V, 1100mAh)	<b>Body-Worn Accessories Tested:</b>	1. Belt-Clip (P/N: BA0102700112KA) 2. Speaker-Microphone (P/N: MH-45)	<b>Max. SAR Measured:</b>	1.44 W/kg - Face-Held (50% Duty Cycle) 2.34 W/kg - Body-Worn (50% Duty Cycle)
<b>Rule Part(s):</b>	FCC 47 CFR §2.1093; IC RSS-102 Issue 1 (Provisional)																										
<b>Test Procedure(s):</b>	FCC OET Bulletin 65, Supplement C (Edition 01-01)																										
<b>Device Classification:</b>	Licensed Non-Broadcast Transmitter Held to Face (TNF)																										
<b>Device Type:</b>	Portable FM VHF PTT Radio Transceiver																										
<b>FCC ID:</b>	K6610503220																										
<b>Model(s):</b>	VX-414-2-5 / VX-424-2-5																										
<b>Modulation:</b>	FM																										
<b>Tx Frequency Range:</b>	146.000 - 174.000 MHz																										
<b>Max. RF Output Power Tested:</b>	5.27 Watts Conducted (146.000 MHz) 5.55 Watts Conducted (160.000 MHz) 4.49 Watts Conducted (174.000 MHz)																										
<b>Antenna Type(s):</b>	1. Whip 146 MHz (P/N: ATV-8A) 2. Whip 160 MHz (P/N: ATV-8B) 3. Whip 174 MHz (P/N: ATV-8C)																										
<b>Battery Type(s):</b>	Nickel-Cadmium (7.2V, 1100mAh)																										
<b>Body-Worn Accessories Tested:</b>	1. Belt-Clip (P/N: BA0102700112KA) 2. Speaker-Microphone (P/N: MH-45)																										
<b>Max. SAR Measured:</b>	1.44 W/kg - Face-Held (50% Duty Cycle) 2.34 W/kg - Body-Worn (50% Duty Cycle)																										

Celltech Labs Inc. declares under its sole responsibility that this wireless portable device has demonstrated compliance with the Specific Absorption Rate (SAR) RF exposure requirements specified in FCC 47 CFR §2.1093 and Health Canada's Safety Code 6. The device was tested in accordance with the measurement standards and procedures specified in FCC OET Bulletin 65, Supplement C (Edition 01-01) and Industry Canada RSS-102 Issue 1 (Provisional) for the Occupational / Controlled Exposure environment. All measurements were performed in accordance with the SAR system manufacturer recommendations.

I attest to the accuracy of data. All measurements were performed by me or were made under my supervision and are correct to the best of my knowledge and belief. I assume full responsibility for the completeness of these measurements and vouch for the qualifications of all persons taking them.

This test report shall not be reproduced partially, or in full, without the prior written approval of Celltech Labs Inc. The results and statements contained in this report pertain only to the device(s) evaluated.



**Russell W. Pipe**  
Senior Compliance Technologist  
Celltech Labs Inc.



<b>TABLE OF CONTENTS</b>		
<b>1.0</b>	<b>INTRODUCTION.....</b>	<b>3</b>
<b>2.0</b>	<b>DESCRIPTION OF DUT.....</b>	<b>3</b>
<b>3.0</b>	<b>SAR MEASUREMENT SYSTEM.....</b>	<b>4</b>
<b>4.0</b>	<b>MEASUREMENT SUMMARY.....</b>	<b>5</b>
<b>5.0</b>	<b>DETAILS OF SAR EVALUATION.....</b>	<b>6</b>
<b>6.0</b>	<b>EVALUATION PROCEDURES.....</b>	<b>6</b>
<b>7.0</b>	<b>SYSTEM PERFORMANCE CHECK.....</b>	<b>7</b>
<b>8.0</b>	<b>SIMULATED TISSUE MIXTURES.....</b>	<b>8</b>
<b>9.0</b>	<b>SAR LIMITS.....</b>	<b>8</b>
<b>10.0</b>	<b>SYSTEM SPECIFICATIONS.....</b>	<b>9</b>
<b>11.0</b>	<b>PROBE SPECIFICATION.....</b>	<b>10</b>
<b>12.0</b>	<b>PLANAR PHANTOM.....</b>	<b>10</b>
<b>13.0</b>	<b>VALIDATION PHANTOM.....</b>	<b>10</b>
<b>14.0</b>	<b>DEVICE HOLDER.....</b>	<b>10</b>
<b>15.0</b>	<b>TEST EQUIPMENT LIST.....</b>	<b>11</b>
<b>16.0</b>	<b>MEASUREMENT UNCERTAINTIES.....</b>	<b>12-13</b>
<b>17.0</b>	<b>REFERENCES.....</b>	<b>14</b>
	<b>APPENDIX A - SAR MEASUREMENT DATA.....</b>	<b>15</b>
	<b>APPENDIX B - SYSTEM PERFORMANCE CHECK DATA.....</b>	<b>16</b>
	<b>APPENDIX C - SYSTEM VALIDATION PROCEDURES.....</b>	<b>17</b>
	<b>APPENDIX D - PROBE CALIBRATION.....</b>	<b>18</b>
	<b>APPENDIX E - MEASURED FLUID DIELECTRIC PARAMETERS.....</b>	<b>19</b>
	<b>APPENDIX F - SAR TEST SETUP &amp; DUT PHOTOGRAPHS.....</b>	<b>20</b>

## 1.0 INTRODUCTION

This measurement report demonstrates compliance of the Vertex Standard Co., Ltd. Models: VX-414-2-5, VX-424-2-5 Portable FM VHF PTT Radio Transceiver FCC ID: K6610503220 with the SAR (Specific Absorption Rate) RF exposure requirements specified in FCC 47 CFR §2.1093 (see reference [1]) and Health Canada Safety Code 6 (see reference [2]) for the Occupational / Controlled Exposure environment. The test procedures described in FCC OET Bulletin 65, Supplement C (Edition 01-01) (see reference [3]) and IC RSS-102 Issue 1 (Provisional) (see reference [4]), were employed. A description of the product and operating configuration, detailed summary of the test results, methodology and procedures used in the evaluation, equipment used, and the various provisions of the rules are included within this test report.

## 2.0 DESCRIPTION OF DEVICE UNDER TEST (DUT)

<b>FCC Rule Part(s)</b>	FCC 47 CFR §2.1093
<b>IC Rule Part(s)</b>	RSS-102 Issue 1 (Provisional)
<b>Test Procedure(s)</b>	FCC OET Bulletin 65, Supplement C (01-01)
<b>Device Classification</b>	Licensed Non-Broadcast Transmitter Held to Face (TNF)
<b>Device Type</b>	Portable FM VHF PTT Radio Transceiver
<b>FCC ID</b>	K6610503220
<b>Model No.(s)</b>	VX-414-2-5 / VX-424-2-5
<b>Serial No.(s)</b>	3K000002 (Identical Prototype)
<b>Modulation</b>	FM
<b>Tx Frequency Range</b>	146.000 - 174.000 MHz
<b>Max. RF Output Power Tested</b>	5.27 Watts Conducted (146.000 MHz) 5.55 Watts Conducted (160.000 MHz) 4.49 Watts Conducted (174.000 MHz)
<b>Battery Type(s)</b>	Nickel-Cadmium (7.2 VDC, 1100 mAh)
<b>Antenna Type(s)</b>	1. Whip 146 MHz (154 mm) (P/N: ATV-8A) 2. Whip 160 MHz (154 mm) (P/N: ATV-8B) 3. Whip 174 MHz (158 mm) (P/N: ATV-8C)
<b>Body-worn Accessories Tested</b>	1. Belt-Clip (P/N: BA0102700112KA) 2. Speaker-Microphone (P/N: MH-45)

### 3.0 SAR MEASUREMENT SYSTEM

Celltech Labs Inc. SAR measurement facility utilizes the Dosimetric Assessment System (DASY™) manufactured by Schmid & Partner Engineering AG (SPEAG™) of Zurich, Switzerland. The DASY4 measurement system is comprised of the measurement server, robot controller, computer, near-field probe, probe alignment sensor, specific anthropomorphic mannequin (SAM) phantom, and various planar phantoms for brain and/or body SAR evaluations. The robot is a six-axis industrial robot performing precise movements to position the probe to the location (points) of maximum electromagnetic field (EMF). A cell controller system contains the power supply, robot controller, teach pendant (Joystick), and remote control, is used to drive the robot motors. The Staubli robot is connected to the cell controller to allow software manipulation of the robot. A data acquisition electronic (DAE) circuit performs the signal amplification, signal multiplexing, AD-conversion, offset measurements, mechanical surface detection, collision detection, etc. is connected to the Electro-optical coupler (EOC). The EOC performs the conversion from the optical into digital electric signal of the DAE and transfers data to the DASY4 measurement server. The DAE4 utilizes a highly sensitive electrometer-grade preamplifier with auto-zeroing, a channel and gain-switching multiplexer, a fast 16-bit AD-converter and a command decoder and control logic unit. Transmission to the DASY4 measurement server is accomplished through an optical downlink for data and status information and an optical uplink for commands and clock lines. The mechanical probe-mounting device includes two different sensor systems for frontal and sidewise probe contacts. The sensor systems are also used for mechanical surface detection and probe collision detection. The robot uses its own controller with a built in VME-bus computer.



DASY4 SAR Measurement System with validation phantom



DASY4 SAR Measurement System with Plexiglas planar phantom

## 4.0 MEASUREMENT SUMMARY

SAR EVALUATION RESULTS														
Freq. (MHz)	Chan.	Test Mode	Test Type	Battery Type	Antenna P/N	Separ. Distance to Planar Phantom (cm)	Body-worn Access. Type	Conducted Power			Measured SAR 1g (W/kg)			
								Before (W)	After (W)	Drift (dB)	100% Duty Cycle		50% Duty Cycle	
146.000	Low	CW	Face-held	7.2V NiCd	ATV-8A	2.5	-	5.08	5.27	0.16	2.88		1.44	
160.000	Mid	CW	Face-held	7.2V NiCd	ATV-8B	2.5	-	5.40	5.55	0.12	2.08		1.04	
174.000	High	CW	Face-held	7.2V NiCd	ATV-8C	2.5	-	4.49	4.43	-0.06	1.39		0.695	
146.000	Low	CW	Body-worn	7.2V NiCd	ATV-8A	1.3	Belt-Clip Spkr-Mic	5.09	4.96	-0.12	P	0.344	P	0.172
											S	0.311	S	0.156
160.000	Mid	CW	Body-worn	7.2V NiCd	ATV-8B	1.3	Belt-Clip Spkr-Mic	5.37	5.51	0.11	P	0.349	P	0.175
											S	0.0803	S	0.0402
174.000	High	CW	Body-worn	7.2V NiCd	ATV-8C	1.3	Belt-Clip Spkr-Mic	4.49	4.36	-0.13	P	4.67	P	2.34
											S	3.00	S	1.50
<b>ANSI / IEEE C95.1 1992 - SAFETY LIMIT</b> <b>BRAIN / BODY: 8.0 W/kg (averaged over 1 gram)</b> <b>Spatial Peak - Occupational / Controlled Exposure</b>														
<b>Dielectric Constant <math>\epsilon_r</math></b>	<b>150 MHz Brain</b>		<b>150 MHz Body</b>		<b>Ambient Temperature</b>		23.3 °C							
	<b>IEEE Target</b>	<b>Measured</b>	<b>IEEE Target</b>	<b>Measured</b>	<b>Fluid Temperature</b>		Brain: 20.6°C		Body: 20.9°C					
	<b>52.3 (± 5%)</b>	54.0	<b>61.9 (± 5%)</b>	61.4	<b>Fluid Depth</b>		≥ 15 cm							
<b>Conductivity <math>\sigma</math> (mho/m)</b>	<b>150 MHz Brain</b>		<b>150 MHz Body</b>		<b><math>\rho</math> (Kg/m<sup>3</sup>)</b>		1000							
	<b>IEEE Target</b>	<b>Measured</b>	<b>IEEE Target</b>	<b>Measured</b>	<b>Relative Humidity</b>		53 %							
	<b>0.76 (± 5%)</b>	0.75	<b>0.80 (± 5%)</b>	0.77	<b>Atmospheric Pressure</b>		102.6 kPa							

Note(s):

- The measurement results were obtained with the DUT tested in the conditions described in this report. Detailed measurement data and plots showing the maximum SAR location of the DUT are reported in Appendix A.
- Secondary peak SAR locations within 2dB of the maximum were evaluated and reported as shown in the table above table and Appendix A (SAR Test Plots) (P = Primary, S = Secondary).
- The ambient and fluid temperatures were measured prior to, and during, the fluid dielectric parameter check and the SAR evaluation. The temperatures reported were consistent for all measurement periods.
- The dielectric parameters of the simulated tissues were measured prior to the evaluation using an 85070C Dielectric Probe Kit and an 8753E Network Analyzer (see Appendix E for printout of measured fluid dielectric parameters).

## 5.0 DETAILS OF SAR EVALUATION

The Vertex Standard Co., Ltd. Models: VX-414-2-5 / VX-424-2-5 Portable FM VHF PTT Radio Transceiver FCC ID: K6610503220 was found to be compliant for localized Specific Absorption Rate (Occupational / Controlled Exposure) based on the test provisions and conditions described below. The detailed test setup photographs are shown in Appendix F.

1. The DUT was evaluated in a face-held configuration with the front of the radio placed parallel to the outer surface of the planar phantom. A 2.5 cm separation distance was maintained between the front side of the DUT and the outer surface of the planar phantom for the duration of the tests.
2. The DUT was evaluated in a body-worn configuration with the back of the radio placed parallel to the outer surface of the planar phantom. The attached belt-clip was touching the planar phantom and provided a 1.3 cm separation distance between the back of the DUT and the outer surface of the planar phantom. The DUT was tested for body-worn SAR with ear-microphone accessory connected.
3. The conducted power levels were measured before and after each test using a Gigatronics 8652A Universal Power Meter according to the procedures described in FCC 47 CFR §2.1046.
4. The DUT was tested in unmodulated continuous transmit operation (Continuous Wave mode at 100% duty cycle) with the transmit key constantly depressed. For a push-to-talk device the 50% duty cycle compensation reported assumes a transmit/receive cycle of equal time base.
5. The DUT was tested with a fully charged NiCd battery.
6. The ambient and fluid temperatures were measured prior to, and during, the fluid dielectric parameter check and the SAR evaluation. The temperatures reported were consistent for all measurement periods.
7. The dielectric parameters of the simulated tissues were measured prior to the evaluation using an 85070C Dielectric Probe Kit and an 8753E Network Analyzer (see Appendix E for printout of measured fluid dielectric parameters).
8. A stack of low-density, low-loss dielectric foamed polystyrene was used in place of the device holder.

## 6.0 EVALUATION PROCEDURES

- a. (i) The evaluation was performed in the applicable area of the phantom depending on the type of device being tested. For devices held to the ear during normal operation, both the left and right ear positions were evaluated using the SAM phantom.  
(ii) For body-worn and face-held devices a planar phantom was used.
- b. The SAR was determined by a pre-defined procedure within the DASY4 software. Upon completion of a reference and optical surface check, the exposed region of the phantom was scanned near the inner surface with a grid spacing of 15mm x 15mm.

An area scan was determined as follows:

- c. Based on the defined area scan grid, a more detailed grid is created to increase the points by a factor of 10. The interpolation function then evaluates all field values between corresponding measurement points.
- d. A linear search is applied to find all the candidate maxima. Subsequently, all maxima are removed that are >2 dB from the global maximum. The remaining maxima are then used to position the cube scans.

A 1g and 10g spatial peak SAR was determined as follows:

1. Extrapolation is used to find the points between the dipole center of the probe and the surface of the phantom. This data cannot be measured, since the center of the dipoles is 2.7 mm away from the tip of the probe and the distance between the surface and the lowest measuring point is 1.4 mm (see probe calibration document in Appendix D). The extrapolation was based on trivariate quadratics computed from the previously calculated 3D interpolated points nearest the phantom surface.
2. Interpolated data is used to calculate the average SAR over 1g and 10g cubes by spatially discretizing the entire measured cube. The volume used to determine the averaged SAR is a 1mm grid (42875 interpolated points).

## 7.0 SYSTEM PERFORMANCE CHECK

Prior to the SAR evaluation a system check was performed using a large Plexiglas planar phantom with a 300MHz dipole (see Appendix C for system validation procedure). The dielectric parameters of the simulated brain tissue were measured prior to the system performance check using an 85070C Dielectric Probe Kit and an 8753E Network Analyzer (see Appendix E for printout of measured fluid dielectric parameters). A forward power of 250mW was applied to the dipole and the system was verified to a tolerance of  $\pm 10\%$  (see Appendix B for system performance check test plot).

SYSTEM PERFORMANCE CHECK													
Test Date	300MHz Equiv. Tissue	SAR 1g (W/kg)		Dielectric Constant $\epsilon_r$		Conductivity $\sigma$ (mho/m)		$\rho$ (Kg/m <sup>3</sup> )	Amb. Temp. (°C)	Fluid Temp. (°C)	Fluid Depth (cm)	Humid. (%)	Barom. Press. (kPa)
		IEEE Target	Measured	IEEE Target	Measured	IEEE Target	Measured						
11/07/03	Brain	0.750 ( $\pm 10\%$ )	0.806 (+7.5%)	45.3 $\pm 5\%$	45.8	0.87 $\pm 5\%$	0.88	1000	23.5	21.2	$\geq 15$	53	102.6

Note(s):

- The ambient and fluid temperatures were measured prior to, and during, the fluid electric parameter check and the system performance check. The temperatures listed in the table above were consistent for all measurement periods.

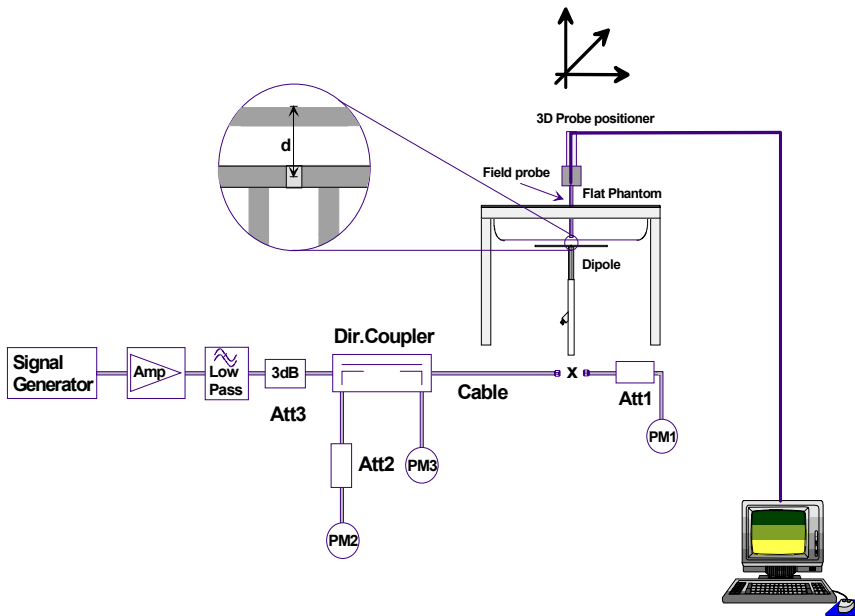

Figure 1. System Performance Check Setup Diagram



300 MHz Dipole Setup

## 8.0 SIMULATED TISSUE MIXTURES

The simulated tissue mixtures consist of a viscous gel using hydroxethylcellulose (HEC) gelling agent and saline solution. Preservation with a bactericide is added and visual inspection is made to ensure air bubbles are not trapped during the mixing process. The fluid was prepared according to standardized procedures and measured for dielectric parameters (permittivity and conductivity).

SIMULATED TISSUE MIXTURES			
INGREDIENT	300 MHz Brain (%) (System Check)	150 MHz Brain (%) (DUT Evaluation)	150 MHz Body (%) (DUT Evaluation)
Water	37.56	38.35	46.6
Sugar	55.32	55.5	49.7
Salt	5.95	5.15	2.6
HEC	0.98	0.9	1.0
Bactericide	0.19	0.1	0.1

## 9.0 SAR SAFETY LIMITS

EXPOSURE LIMITS	SAR (W/kg)	
	(General Population / Uncontrolled Exposure Environment)	(Occupational / Controlled Exposure Environment)
Spatial Average (averaged over the whole body)	0.08	0.4
Spatial Peak (averaged over any 1g of tissue)	1.60	8.0
Spatial Peak (hands/wrists/feet/ankles averaged over 10g)	4.0	20.0

Notes:

1. Uncontrolled environments are defined as locations where there is potential exposure of individuals who have no knowledge or control of their potential exposure.
2. Controlled environments are defined as locations where there is potential exposure of individuals who have knowledge of their potential exposure and can exercise control over their exposure.



## 10.0 ROBOT SYSTEM SPECIFICATIONS

### Specifications

**POSITIONER:** Stäubli Unimation Corp. Robot Model: RX60L  
**Repeatability:** 0.02 mm  
**No. of axis:** 6

### Data Acquisition Electronic (DAE) System

#### Cell Controller

**Processor:** AMD Athlon XP 2400+  
**Clock Speed:** 2.0 GHz  
**Operating System:** Windows XP Professional

#### Data Converter

**Features:** Signal Amplifier, multiplexer, A/D converter, and control logic  
**Software:** DASY4 software  
**Connecting Lines:** Optical downlink for data and status info.  
 Optical uplink for commands and clock

### DASY4 Measurement Server

**Function:** Real-time data evaluation for field measurements and surface detection  
**Hardware:** PC/104 166MHz Pentium CPU; 32 MB chipdisk; 64 MB RAM  
**Connections:** COM1, COM2, DAE, Robot, Ethernet, Service Interface

### E-Field Probe

**Model:** ET3DV6  
**Serial No.:** 1387  
**Construction:** Triangular core fiber optic detection system  
**Frequency:** 10 MHz to 6 GHz  
**Linearity:** ±0.2 dB (30 MHz to 3 GHz)

### Evaluation Phantom

**Type:** Planar Phantom  
**Shell Material:** Plexiglas  
**Bottom Thickness:** 2.0 mm ± 0.1 mm  
**Outer Dimensions:** 75.0 cm (L) x 22.5 cm (W) x 20.5 cm (H); Back Plane: 25.7 cm (H)

### Validation Phantom (≤ 450MHz)

**Type:** Planar Phantom  
**Shell Material:** Plexiglas  
**Bottom Thickness:** 6.2 mm ± 0.1 mm  
**Outer Dimensions:** 86.0 cm (L) x 39.5 cm (W) x 21.8 cm (H)

## 11.0 PROBE SPECIFICATION (ET3DV6)

Construction:	Symmetrical design with triangular core Built-in shielding against static charges PEEK enclosure material (resistant to organic solvents, e.g. glycol)
Calibration:	In air from 10 MHz to 2.5 GHz In brain simulating tissue at frequencies of 900 MHz and 1.8 GHz (accuracy $\pm 8\%$ )
Frequency:	10 MHz to > 6 GHz; Linearity: $\pm 0.2$ dB (30 MHz to 3 GHz)
Directivity:	$\pm 0.2$ dB in brain tissue (rotation around probe axis) $\pm 0.4$ dB in brain tissue (rotation normal to probe axis)
Dynamic Range:	5 $\mu$ W/g to > 100 mW/g; Linearity: $\pm 0.2$ dB
Surface Detect.:	$\pm 0.2$ mm repeatability in air and clear liquids over diffuse reflecting surfaces
Dimensions:	Overall length: 330 mm Tip length: 16 mm Body diameter: 12 mm Tip diameter: 6.8 mm Distance from probe tip to dipole centers: 2.7 mm
Application:	General dosimetry up to 3 GHz Compliance tests of mobile phone



ET3DV6 E-Field Probe

## 12.0 PLANAR PHANTOM

The planar phantom is constructed of Plexiglas material with a 2.0 mm shell thickness for face-held and body-worn SAR evaluations of handheld radio transceivers. The planar phantom is mounted on the side of the DASY4 system



Plexiglas Planar Phantom

## 13.0 VALIDATION PLANAR PHANTOM

The validation planar phantom is constructed of Plexiglas material with a 6.0 mm shell thickness for SAR validations at 450MHz and below. The validation planar phantom is mounted in the DASY4 compact system.



Validation Planar Phantom

## 14.0 DEVICE HOLDER

The DASY4 device holder has two scales for device rotation (with respect to the body axis) and the device inclination (with respect to the line between the ear openings). The plane between the ear openings and the mouth tip has a rotation angle of 65°. The bottom plate contains three pair of bolts for locking the device holder. The device holder positions are adjusted to the standard measurement positions in the three sections.



Device Holder

## 15.0 TEST EQUIPMENT LIST

TEST EQUIPMENT	SERIAL NO.	CALIBRATION DATE
Schmid & Partner DASY4 System	-	-
DASY4 Measurement Server	1078	N/A
-Robot	599396-01	N/A
-ET3DV6 E-Field Probe	1387	Feb 2003
-300MHz Validation Dipole	135	Oct 2003
-450MHz Validation Dipole	136	Nov 2003
-900MHz Validation Dipole	054	June 2003
-1800MHz Validation Dipole	247	June 2003
-2450MHz Validation Dipole	150	Sept 2003
-Plexiglas Planar Phantom	161	N/A
-Validation Planar Phantom	137	N/A
HP 85070C Dielectric Probe Kit	N/A	N/A
Gigatronics 8651A Power Meter	8650137	April 2003
Gigatronics 8652A Power Meter	1835267	April 2003
Power Sensor 80701A	1833542	Feb 2003
Power Sensor 80701A	1833699	April 2003
HP E4408B Spectrum Analyzer	US39240170	Dec 2002
HP 8594E Spectrum Analyzer	3543A02721	April 2003
HP 8753E Network Analyzer	US38433013	May 2003
HP 8648D Signal Generator	3847A00611	May 2003
Amplifier Research 5S1G4 Power Amplifier	26235	N/A

## 16.0 MEASUREMENT UNCERTAINTIES

UNCERTAINTY BUDGET FOR DEVICE EVALUATION						
Error Description	Uncertainty Value ±%	Probability Distribution	Divisor	C <sub>i</sub> 1g	Standard Uncertainty ±% (1g)	v <sub>i</sub> or v <sub>eff</sub>
<b>Measurement System</b>						
Probe calibration	± 4.8	Normal	1	1	± 4.8	∞
Axial isotropy of the probe	± 4.7	Rectangular	√3	(1-C <sub>p</sub> )	± 1.9	∞
Spherical isotropy of the probe	± 9.6	Rectangular	√3	(C <sub>p</sub> )	± 3.9	∞
Spatial resolution	± 0.0	Rectangular	√3	1	± 0.0	∞
Boundary effects	± 5.5	Rectangular	√3	1	± 3.2	∞
Probe linearity	± 4.7	Rectangular	√3	1	± 2.7	∞
Detection limit	± 1.0	Rectangular	√3	1	± 0.6	∞
Readout electronics	± 1.0	Normal	1	1	± 1.0	∞
Response time	± 0.8	Rectangular	√3	1	± 0.5	∞
Integration time	± 1.4	Rectangular	√3	1	± 0.8	∞
RF ambient conditions	± 3.0	Rectangular	√3	1	± 1.7	∞
Mech. constraints of robot	± 0.4	Rectangular	√3	1	± 0.2	∞
Probe positioning	± 2.9	Rectangular	√3	1	± 1.7	∞
Extrapolation & integration	± 3.9	Rectangular	√3	1	± 2.3	∞
<b>Test Sample Related</b>						
Device positioning	± 6.0	Normal	√3	1	± 6.7	12
Device holder uncertainty	± 5.0	Normal	√3	1	± 5.9	8
Power drift	± 5.0	Rectangular	√3		± 2.9	∞
<b>Phantom and Setup</b>						
Phantom uncertainty	± 4.0	Rectangular	√3	1	± 2.3	∞
Liquid conductivity (target)	± 5.0	Rectangular	√3	0.6	± 1.7	∞
Liquid conductivity (measured)	± 5.0	Rectangular	√3	0.6	± 1.7	∞
Liquid permittivity (target)	± 5.0	Rectangular	√3	0.6	± 1.7	∞
Liquid permittivity (measured)	± 5.0	Rectangular	√3	0.6	± 1.7	∞
<b>Combined Standard Uncertainty</b>					<b>± 13.3</b>	
<b>Expanded Uncertainty (k=2)</b>					<b>± 26.6</b>	

Measurement Uncertainty Table in accordance with IEEE Standard 1528-200X (Draft - see reference [5])

## MEASUREMENT UNCERTAINTIES (Cont.)

UNCERTAINTY BUDGET FOR SYSTEM VALIDATION						
Error Description	Uncertainty Value ±%	Probability Distribution	Divisor	C <sub>i</sub> 1g	Standard Uncertainty ±% (1g)	v <sub>i</sub> or v <sub>eff</sub>
<b>Measurement System</b>						
Probe calibration	± 4.8	Normal	1	1	± 4.8	∞
Axial isotropy of the probe	± 4.7	Rectangular	√3	(1-C <sub>p</sub> )	± 1.9	∞
Spherical isotropy of the probe	± 9.6	Rectangular	√3	(C <sub>p</sub> )	± 3.9	∞
Spatial resolution	± 0.0	Rectangular	√3	1	± 0.0	∞
Boundary effects	± 5.5	Rectangular	√3	1	± 3.2	∞
Probe linearity	± 4.7	Rectangular	√3	1	± 2.7	∞
Detection limit	± 1.0	Rectangular	√3	1	± 0.6	∞
Readout electronics	± 1.0	Normal	1	1	± 1.0	∞
Response time	± 0.8	Rectangular	√3	1	± 0.5	∞
Integration time	± 1.4	Rectangular	√3	1	± 0.8	∞
RF ambient conditions	± 3.0	Rectangular	√3	1	± 1.7	∞
Mech. constraints of robot	± 0.4	Rectangular	√3	1	± 0.2	∞
Probe positioning	± 2.9	Rectangular	√3	1	± 1.7	∞
Extrapolation & integration	± 3.9	Rectangular	√3	1	± 2.3	∞
<b>Dipole</b>						
Dipole Axis to Liquid Distance	± 2.0	Rectangular	√3	1	± 1.2	∞
Input Power	± 4.7	Rectangular	√3	1	± 2.7	∞
<b>Phantom and Setup</b>						
Phantom uncertainty	± 4.0	Rectangular	√3	1	± 2.3	∞
Liquid conductivity (target)	± 5.0	Rectangular	√3	0.6	± 1.7	∞
Liquid conductivity (measured)	± 5.0	Rectangular	√3	0.6	± 1.7	∞
Liquid permittivity (target)	± 5.0	Rectangular	√3	0.6	± 1.7	∞
Liquid permittivity (measured)	± 5.0	Rectangular	√3	0.6	± 1.7	∞
<b>Combined Standard Uncertainty</b>					<b>± 9.9</b>	
<b>Expanded Uncertainty (k=2)</b>					<b>± 19.8</b>	

Measurement Uncertainty Table in accordance with IEEE Standard 1528-200X (Draft - see reference [5])

Test Report S/N:	102803-441K66
Test Date(s):	November 07, 2003
Test Type:	FCC/IC SAR Evaluation

## 17.0 REFERENCES

- [1] Federal Communications Commission, "Radiofrequency radiation exposure evaluation: portable devices", Rule Part 47 CFR §2.1093: 1999.
- [2] Health Canada, "Limits of Human Exposure to Radiofrequency Electromagnetic Fields in the Frequency Range from 3 kHz to 300 GHz", Safety Code 6.
- [3] Federal Communications Commission, "Evaluating Compliance with FCC Guidelines for Human Exposure to Radio frequency Electromagnetic Fields", OET Bulletin 65, Supplement C (Edition 01-01), FCC, Washington, D.C.: June 2001.
- [4] Industry Canada, "Evaluation Procedure for Mobile and Portable Radio Transmitters with respect to Health Canada's Safety Code 6 for Exposure of Humans to Radio Frequency Fields", Radio Standards Specification RSS-102 Issue 1 (Provisional): September 1999.
- [5] IEEE Standards Coordinating Committee 34, Std 1528-200X, "DRAFT Recommended Practice for Determining the Spatial-Peak Specific Absorption Rate (SAR) in the Human Body Due to Wireless Communications Devices: Experimental Techniques".

Test Report S/N:	102803-441K66
Test Date(s):	November 07, 2003
Test Type:	FCC/IC SAR Evaluation

## APPENDIX A - SAR MEASUREMENT DATA

Date Tested: 11/07/03

DUT: Vertex Standard Co., Ltd.; Model: VX-414-2-5; Type: FM VHF PTT Radio Transceiver; Serial: 3K000002

Ambient Temp: 23.3°C; Fluid Temp: 20.6°C; Barometric Pressure: 102.6 kPa; Humidity: 53%

Communication System: FM VHF  
 RF Output Power: 5.27 Watts (Conducted)  
 Frequency: 146 MHz; Duty Cycle: 1:1  
 Medium: HSL150 ( $\sigma = 0.75 \text{ mho/m}$ ,  $\epsilon_r = 54$ ,  $\rho = 1000 \text{ kg/m}^3$ )

- Probe: ET3DV6 - SN1387; ConvF(9.1, 9.1, 9.1); Calibrated: 26/02/2003
- Sensor-Surface: 4mm (Mechanical Surface Detection)
- Electronics: DAE3 Sn370; Calibrated: 19/05/2003
- Phantom: Planar; Type: Plexiglas; Serial: 161
- Measurement SW: DASY4, V4.1 Build 47; Postprocessing SW: SEMCAD, V1.6 Build 116

**Face-Held Low Chan. 146 MHz Antenna/Area Scan (7x20x1):** Measurement grid: dx=15mm, dy=15mm

**Face-Held Low Chan. 146 MHz Antenna/Zoom Scan (7x7x7)/Cube 0:** Measurement grid: dx=5mm, dy=5mm, dz=5mm

Peak SAR (extrapolated) = 4.47 W/kg  
**SAR(1 g) = 2.88 mW/g; SAR(10 g) = 2.13 mW/g**  
 Reference Value = 61.8 V/m  
 Power Drift = 0.16 dB

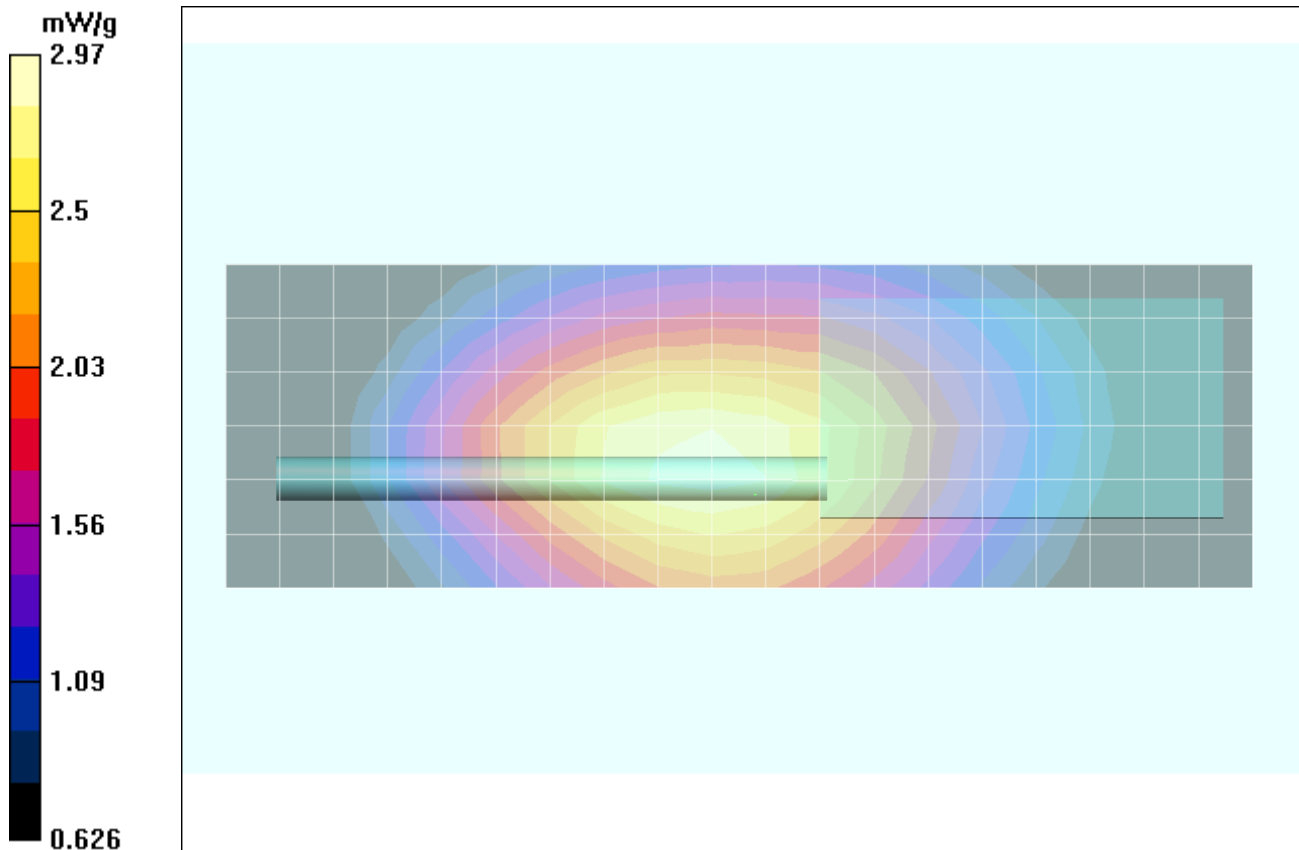



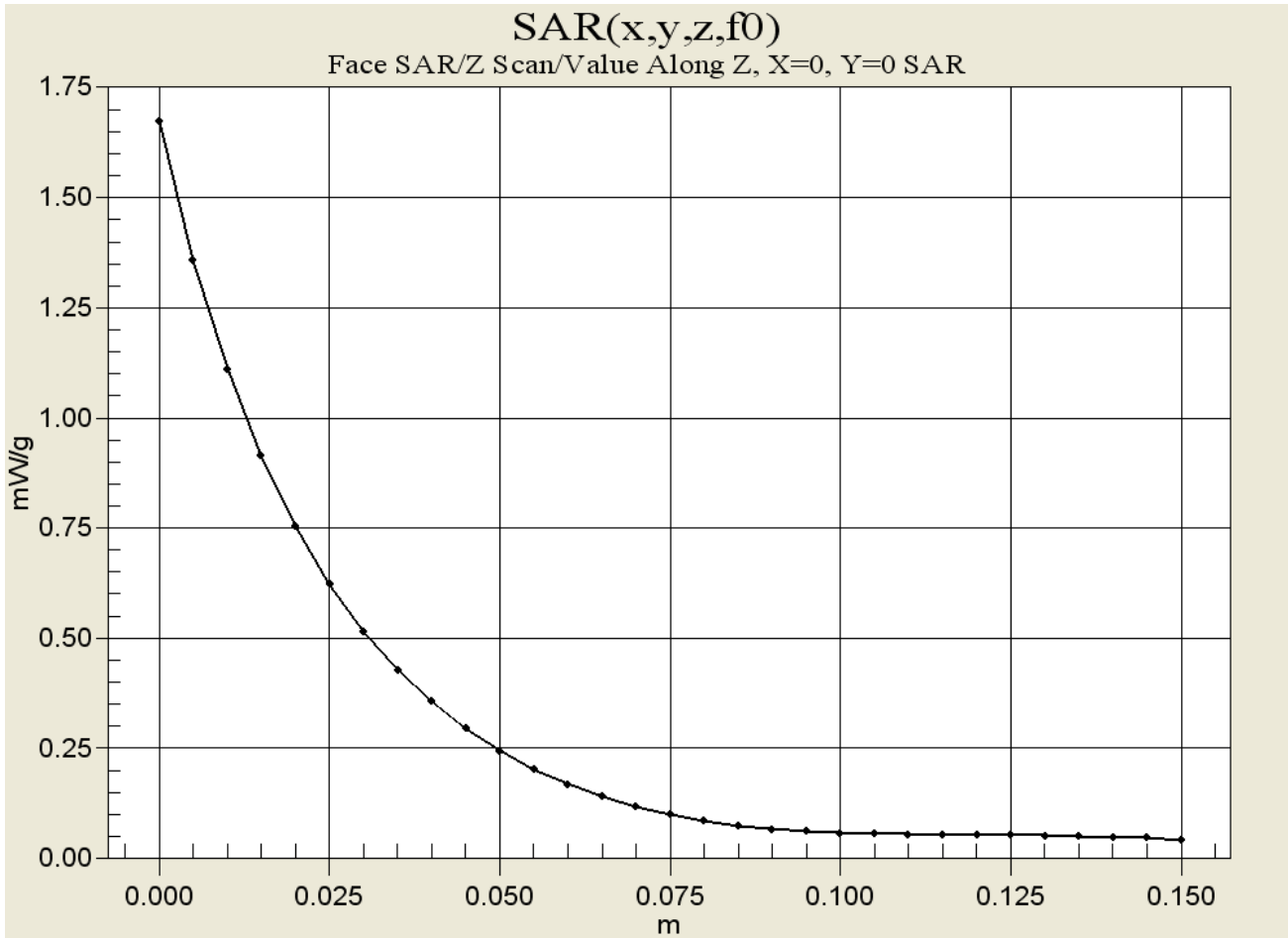

Date Tested: 11/07/03

DUT: Vertex Standard Co., Ltd.; Model: VX-414-2-5; Type: FM VHF PTT Radio Transceiver; Serial: 3K000002

Ambient Temp: 23.3°C; Fluid Temp: 20.6°C; Barometric Pressure: 102.6 kPa; Humidity: 53%

Communication System: FM VHF  
 RF Output Power: 5.55 Watts (Conducted)  
 Frequency: 160 MHz; Duty Cycle: 1:1  
 Medium: HSL150 ( $\sigma = 0.75 \text{ mho/m}$ ,  $\epsilon_r = 54$ ,  $\rho = 1000 \text{ kg/m}^3$ )

- Probe: ET3DV6 - SN1387; ConvF(9.1, 9.1, 9.1); Calibrated: 26/02/2003
- Sensor-Surface: 4mm (Mechanical Surface Detection)
- Electronics: DAE3 Sn370; Calibrated: 19/05/2003
- Phantom: Planar; Type: Plexiglas; Serial: 161
- Measurement SW: DAS4, V4.1 Build 47; Postprocessing SW: SEMCAD, V1.6 Build 116

**Face-Held Mid Chan. 160 MHz Antenna/Area Scan (7x20x1):** Measurement grid: dx=15mm, dy=15mm

**Face-Held Mid Chan. 160 MHz Antenna/Zoom Scan (7x7x7)/Cube 0:** Measurement grid: dx=5mm, dy=5mm, dz=5mm  
 Peak SAR (extrapolated) = 3.24 W/kg  
**SAR(1 g) = 2.08 mW/g; SAR(10 g) = 1.53 mW/g**  
 Reference Value = 48.8 V/m  
 Power Drift = 0.11 dB

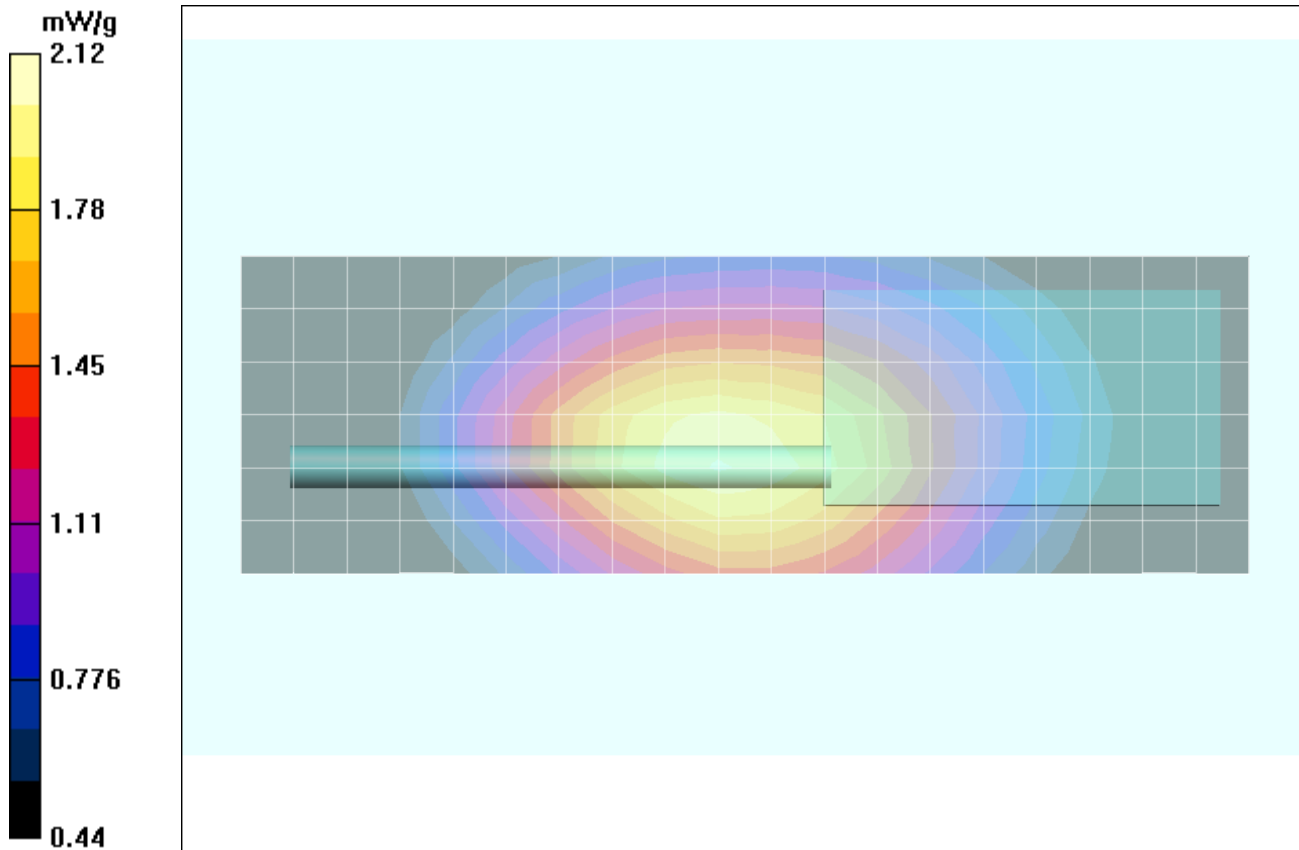

Date Tested: 11/07/03

DUT: Vertex Standard Co., Ltd.; Model: VX-414-2-5; Type: FM VHF PTT Radio Transceiver; Serial: 3K000002

Ambient Temp: 23.3°C; Fluid Temp: 20.6°C; Barometric Pressure: 102.6 kPa; Humidity: 53%

Communication System: FM VHF  
 RF Output Power: 4.49 Watts (Conducted)  
 Frequency: 174 MHz; Duty Cycle: 1:1  
 Medium: HSL150 ( $\sigma = 0.75 \text{ mho/m}$ ,  $\epsilon_r = 54$ ,  $\rho = 1000 \text{ kg/m}^3$ )

- Probe: ET3DV6 - SN1387; ConvF(9.1, 9.1, 9.1); Calibrated: 26/02/2003
- Sensor-Surface: 4mm (Mechanical Surface Detection)
- Electronics: DAE3 Sn370; Calibrated: 19/05/2003
- Phantom: Planar; Type: Plexiglas; Serial: 161
- Measurement SW: DASy4, V4.1 Build 47; Postprocessing SW: SEMCAD, V1.6 Build 116

**Face-Held High Chan. 174 MHz Antenna/Area Scan (7x20x1):** Measurement grid: dx=15mm, dy=15mm

**Face-Held High Chan. 174 MHz Antenna/Zoom Scan (7x7x7)/Cube 0:** Measurement grid: dx=5mm, dy=5mm, dz=5mm

Peak SAR (extrapolated) = 2.19 W/kg  
**SAR(1 g) = 1.39 mW/g; SAR(10 g) = 1.01 mW/g**  
 Reference Value = 40.5 V/m  
 Power Drift = -0.06 dB

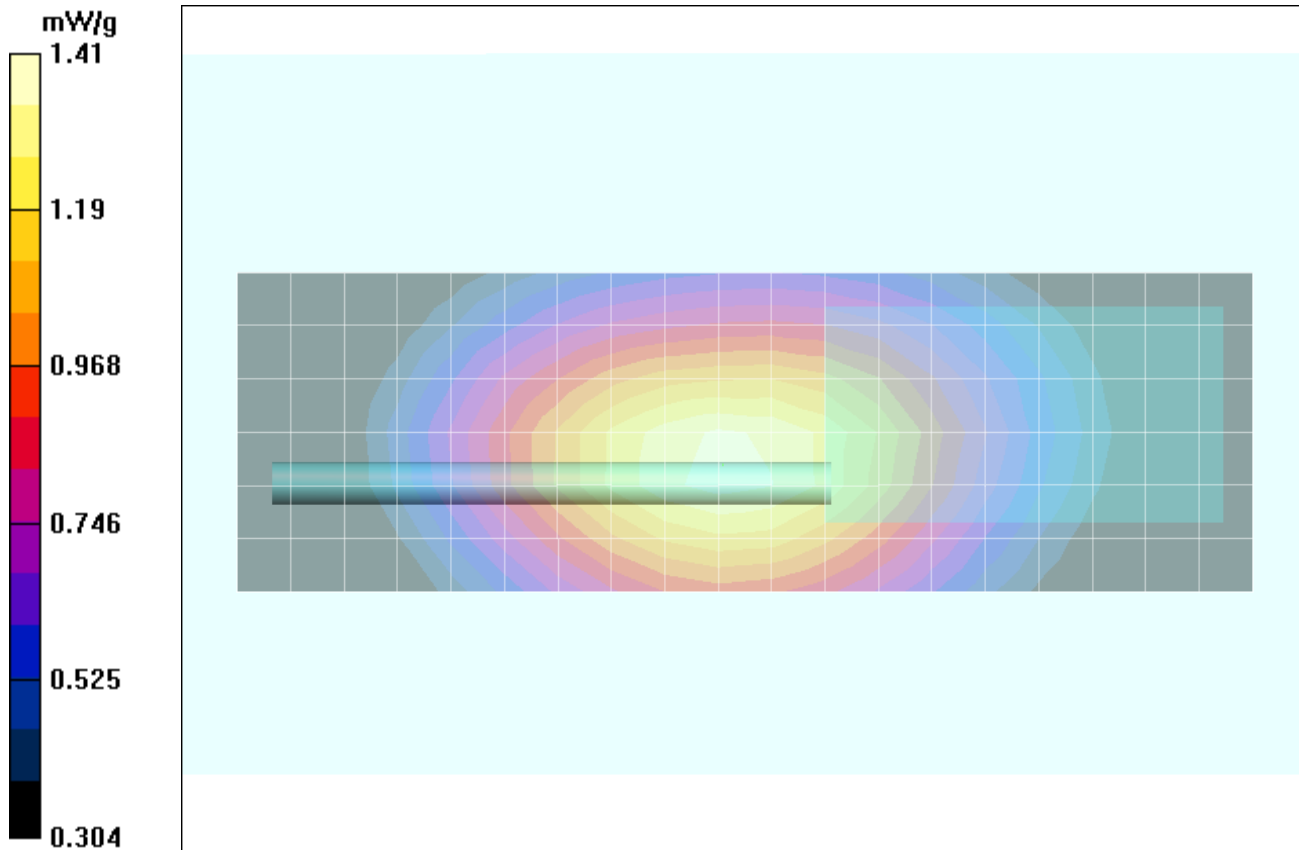

Date Tested: 11/07/03

DUT: Vertex Standard Co., Ltd.; Model: VX-414-2-5; Type: FM VHF PTT Radio Transceiver; Serial: 3K000002

Ambient Temp: 23.3°C; Fluid Temp: 20.9°C; Barometric Pressure: 102.6 kPa; Humidity: 53%

Communication System: FM VHF  
 RF Output Power: 5.09 Watts (Conducted)  
 Frequency: 146 MHz; Duty Cycle: 1:1  
 Medium: M150 ( $\sigma = 0.77$  mho/m,  $\epsilon_r = 61.4$ ,  $\rho = 1000$  kg/m<sup>3</sup>)

- Probe: ET3DV6 - SN1387; ConvF(8.8, 8.8, 8.8); Calibrated: 26/02/2003
- Sensor-Surface: 4mm (Mechanical Surface Detection)
- Electronics: DAE3 Sn370; Calibrated: 19/05/2003
- Phantom: Planar; Type: Plexiglas; Serial: 161
- Measurement SW: DASy4, V4.1 Build 47; Postprocessing SW: SEMCAD, V1.6 Build 116

**Body-Worn Low Chan. 146 MHz Antenna/Area Scan (9x20x1):** Measurement grid: dx=15mm, dy=15mm  
**Body-Worn Low Chan. 146 MHz Antenna/Zoom Scan (7x7x7)/Cube 0:** Measurement grid: dx=5mm, dy=5mm, dz=5mm  
 Peak SAR (extrapolated) = 0.636 W/kg  
**SAR(1 g) = 0.344 mW/g; SAR(10 g) = 0.239 mW/g**  
 Reference Value = 17.4 V/m  
 Power Drift = -0.11 dB  
**Body-Worn Low Chan. 146 MHz Antenna/Zoom Scan (7x7x7)/Cube 1:** Measurement grid: dx=5mm, dy=5mm, dz=5mm  
 Peak SAR (extrapolated) = 1.09 W/kg  
**SAR(1 g) = 0.311 mW/g; SAR(10 g) = 0.188 mW/g**  
 Reference Value = 17.4 V/m  
 Power Drift = -0.11 dB

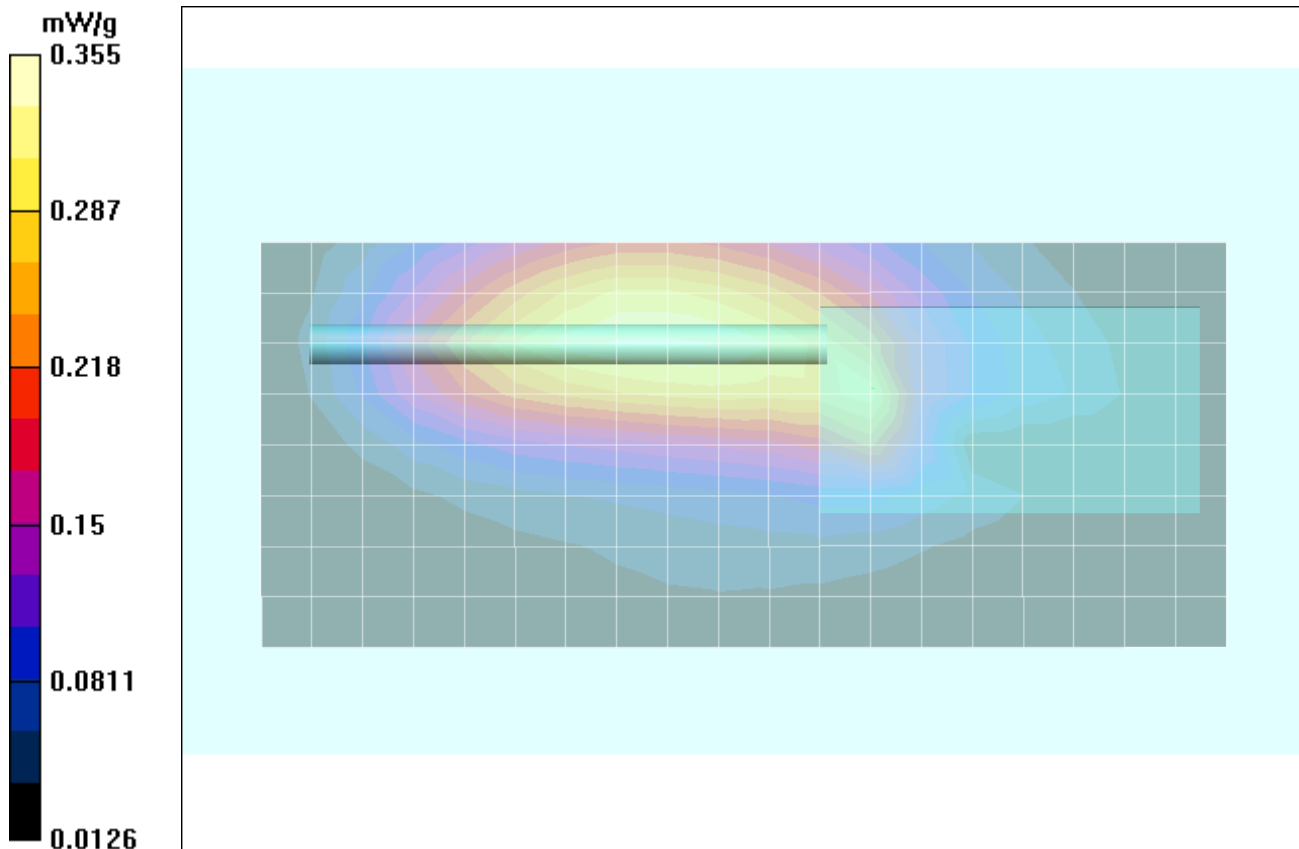

Date Tested: 11/07/03

DUT: Vertex Standard Co., Ltd.; Model: VX-414-2-5; Type: FM VHF PTT Radio Transceiver; Serial: 3K000002

Ambient Temp: 23.3°C; Fluid Temp: 20.9°C; Barometric Pressure: 102.6 kPa; Humidity: 53%

Communication System: FM VHF  
 RF Output Power: 5.51 Watts (Conducted)  
 Frequency: 160 MHz; Duty Cycle: 1:1  
 Medium: M150 ( $\sigma = 0.77$  mho/m,  $\epsilon_r = 61.4$ ,  $\rho = 1000$  kg/m<sup>3</sup>)

- Probe: ET3DV6 - SN1387; ConvF(8.8, 8.8, 8.8); Calibrated: 26/02/2003
- Sensor-Surface: 4mm (Mechanical Surface Detection)
- Electronics: DAE3 Sn370; Calibrated: 19/05/2003
- Phantom: Planar; Type: Plexiglas; Serial: 161
- Measurement SW: DASY4, V4.1 Build 47; Postprocessing SW: SEMCAD, V1.6 Build 116

**Body-Worn Mid Chan. 160 MHz Antenna/Area Scan (9x20x1):** Measurement grid: dx=15mm, dy=15mm  
**Body-Worn Mid Chan. 160 MHz Antenna/Zoom Scan (7x7x7)/Cube 0:** Measurement grid: dx=5mm, dy=5mm, dz=5mm  
 Peak SAR (extrapolated) = 1.03 W/kg  
**SAR(1 g) = 0.349 mW/g; SAR(10 g) = 0.183 mW/g**  
 Reference Value = 14.2 V/m  
 Power Drift = 0.1 dB  
**Body-Worn Mid Chan. 160 MHz Antenna/Zoom Scan (7x7x7)/Cube 1:** Measurement grid: dx=5mm, dy=5mm, dz=5mm  
 Peak SAR (extrapolated) = 0.137 W/kg  
**SAR(1 g) = 0.0803 mW/g; SAR(10 g) = 0.054 mW/g**  
 Reference Value = 14.2 V/m  
 Power Drift = 0.1 dB

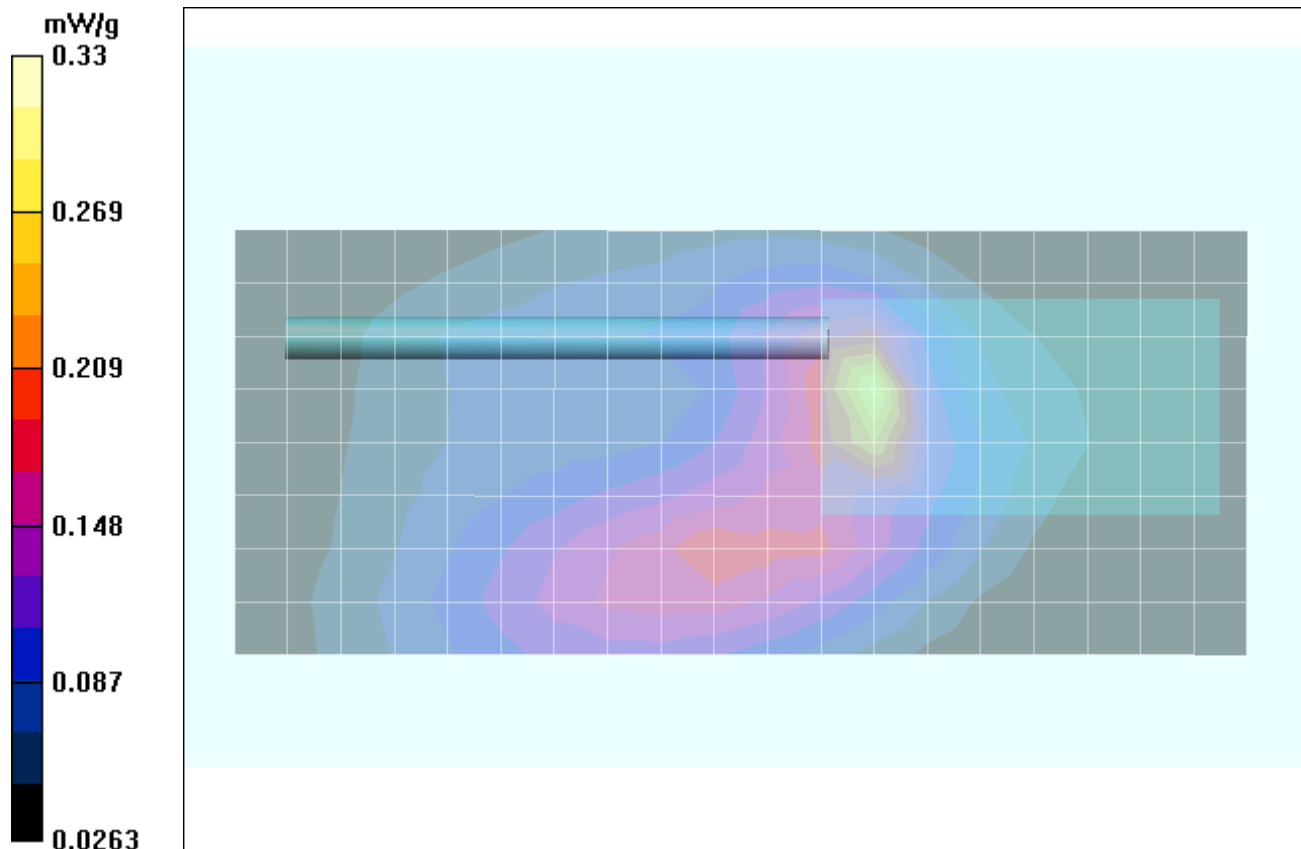

Date Tested: 11/07/03

DUT: Vertex Standard Co., Ltd.; Model: VX-414-2-5; Type: FM VHF PTT Radio Transceiver; Serial: 3K000002

Ambient Temp: 23.3°C; Fluid Temp: 20.9°C; Barometric Pressure: 102.6 kPa; Humidity: 53%

Communication System: FM VHF  
 RF Output Power: 4.49 Watts (Conducted)  
 Frequency: 174 MHz; Duty Cycle: 1:1  
 Medium: M150 ( $\sigma = 0.77 \text{ mho/m}$ ,  $\epsilon_r = 61.4$ ,  $\rho = 1000 \text{ kg/m}^3$ )

- Probe: ET3DV6 - SN1387; ConvF(8.8, 8.8, 8.8); Calibrated: 26/02/2003
- Sensor-Surface: 4mm (Mechanical Surface Detection)
- Electronics: DAE3 Sn370; Calibrated: 19/05/2003
- Phantom: Planar; Type: Plexiglas; Serial: 161
- Measurement SW: DASy4, V4.1 Build 47; Postprocessing SW: SEMCAD, V1.6 Build 116

**Body-Worn High Chan. 174 MHz Antenna/Area Scan (9x20x1):** Measurement grid: dx=15mm, dy=15mm  
**Body-Worn High Chan. 174 MHz Antenna/Zoom Scan (7x7x7)/Cube 0:** Measurement grid: dx=5mm, dy=5mm, dz=5mm  
 Peak SAR (extrapolated) = 13 W/kg  
**SAR(1 g) = 4.67 mW/g; SAR(10 g) = 2.63 mW/g**  
 Reference Value = 70.2 V/m  
 Power Drift = -0.13 dB  
**Body-Worn High Chan. 174 MHz Antenna/Zoom Scan (7x7x7)/Cube 1:** Measurement grid: dx=5mm, dy=5mm, dz=5mm  
 Peak SAR (extrapolated) = 4.63 W/kg  
**SAR(1 g) = 3 mW/g; SAR(10 g) = 2.2 mW/g**  
 Reference Value = 70.2 V/m  
 Power Drift = -0.13 dB

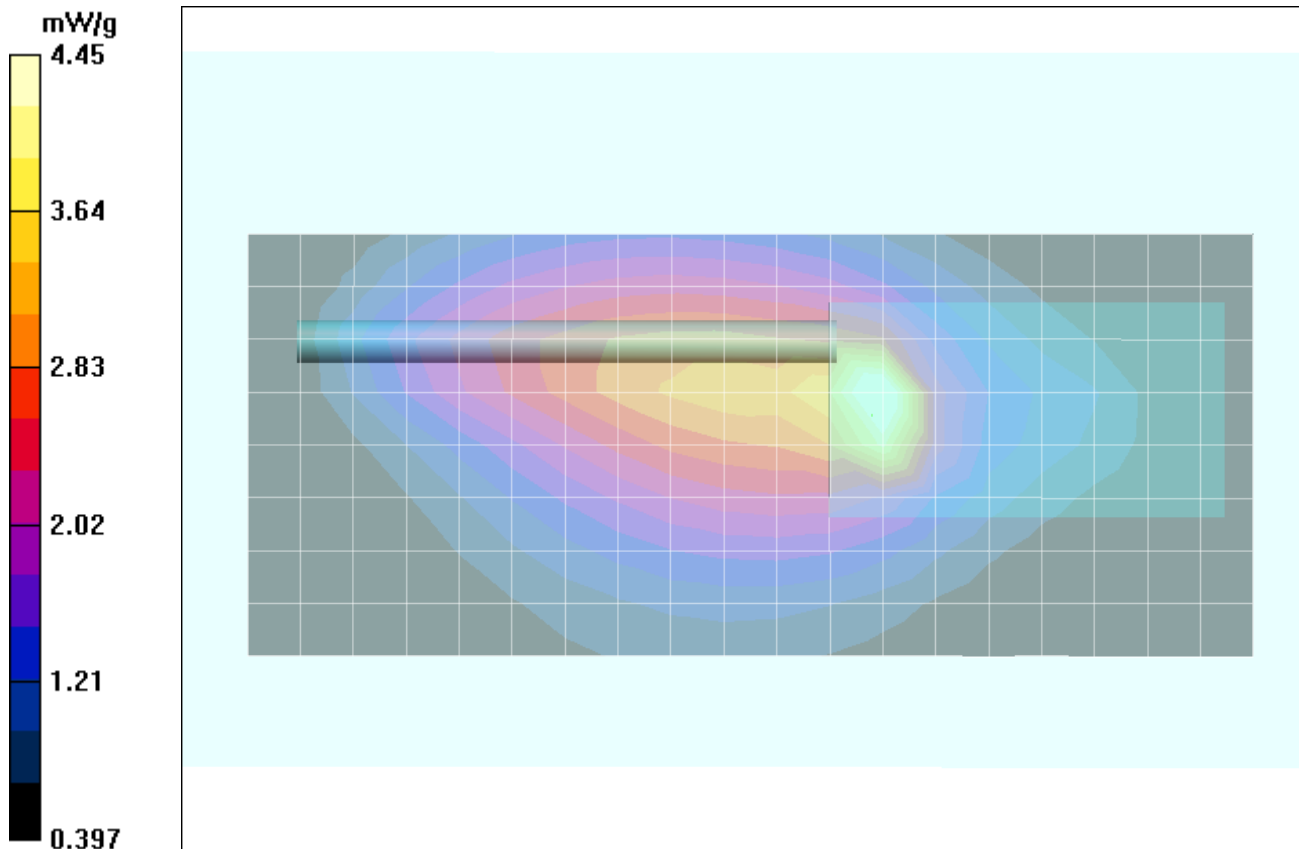

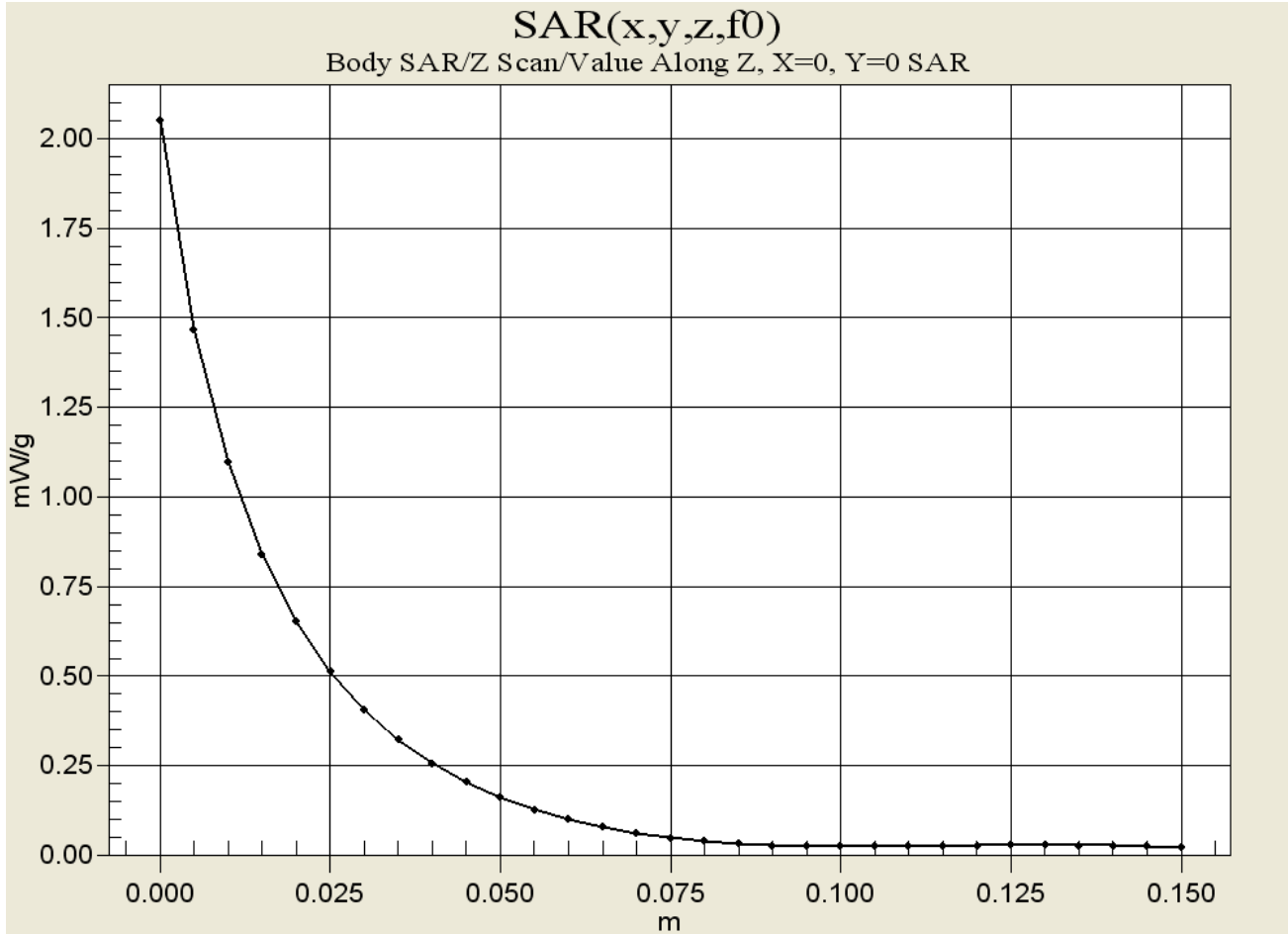

Test Report S/N:	102803-441K66
Test Date(s):	November 07, 2003
Test Type:	FCC/IC SAR Evaluation

**APPENDIX B - SYSTEM PERFORMANCE CHECK DATA**



Date Tested: 11/07/03

DUT: Dipole 300 MHz; Model: D300V2; Type: System Performance Check; Serial: 135

Ambient Temp: 23.5°C; Fluid Temp: 21.2°C; Barometric Pressure: 102.6 kPa; Humidity: 53%

Communication System: CW  
 Forward Conducted Power: 250 mW  
 Frequency: 300 MHz; Duty Cycle: 1:1  
 Medium: 300 HSL ( $\sigma = 0.88 \text{ mho/m}$ ,  $\epsilon_r = 45.8$ ,  $\rho = 1000 \text{ kg/m}^3$ )

- Probe: ET3DV6 - SN1387; ConvF(7.9, 7.9, 7.9); Calibrated: 26/02/2003
- Sensor-Surface: 4mm (Mechanical Surface Detection)
- Electronics: DAE3 Sn370; Calibrated: 19/05/2003
- Phantom: Validation Planar; Type: Plexiglas; Serial: 137
- Measurement SW: DASY4, V4.1 Build 47; Postprocessing SW: SEMCAD, V1.6 Build 116

**300 MHz Validation/Area Scan (6x11x1):** Measurement grid: dx=15mm, dy=15mm

**300 MHz Validation/Zoom Scan (7x7x7)/Cube 0:** Measurement grid: dx=5mm, dy=5mm, dz=5mm

Peak SAR (extrapolated) = 1.43 W/kg  
**SAR(1 g) = 0.806 mW/g; SAR(10 g) = 0.514 mW/g**  
 Reference Value = 30.7 V/m  
 Power Drift = -0.1 dB

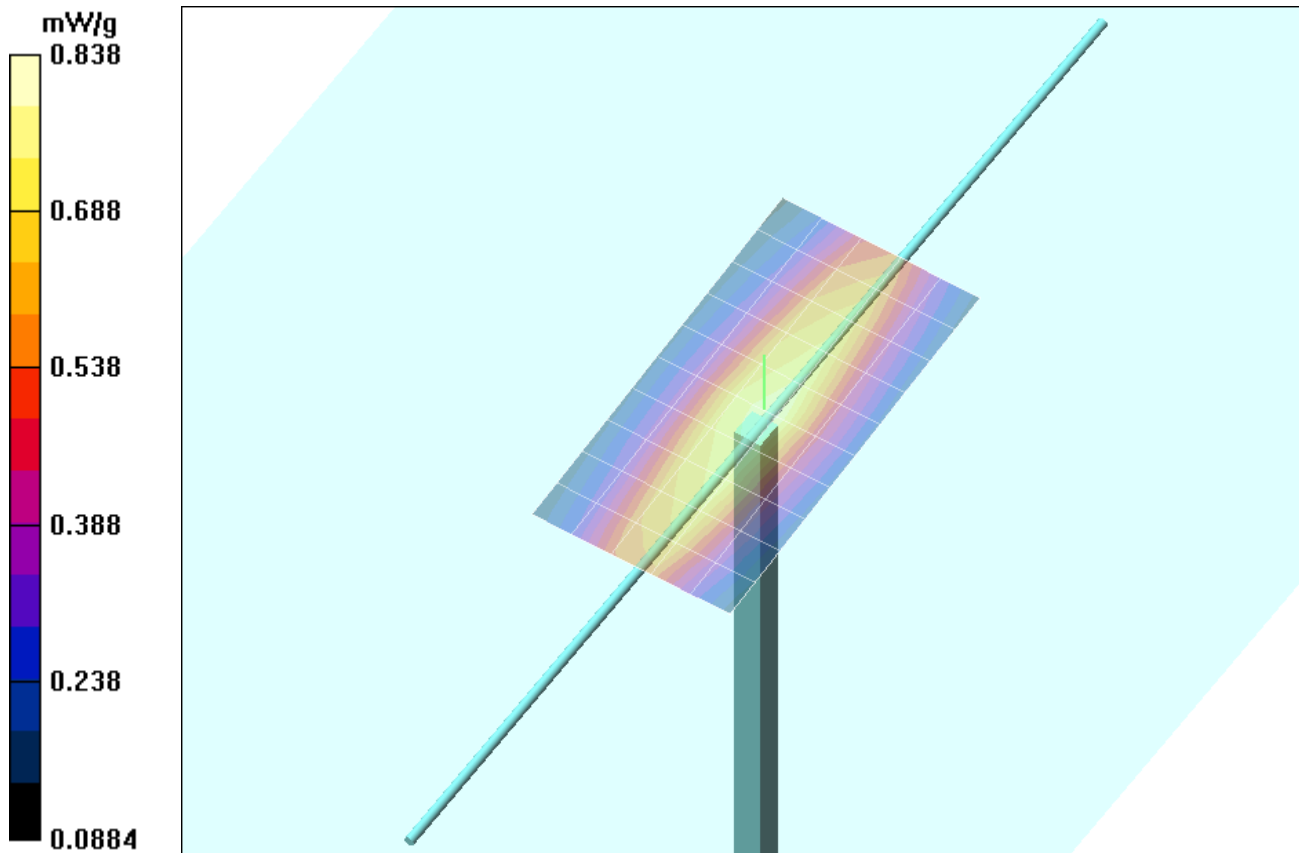

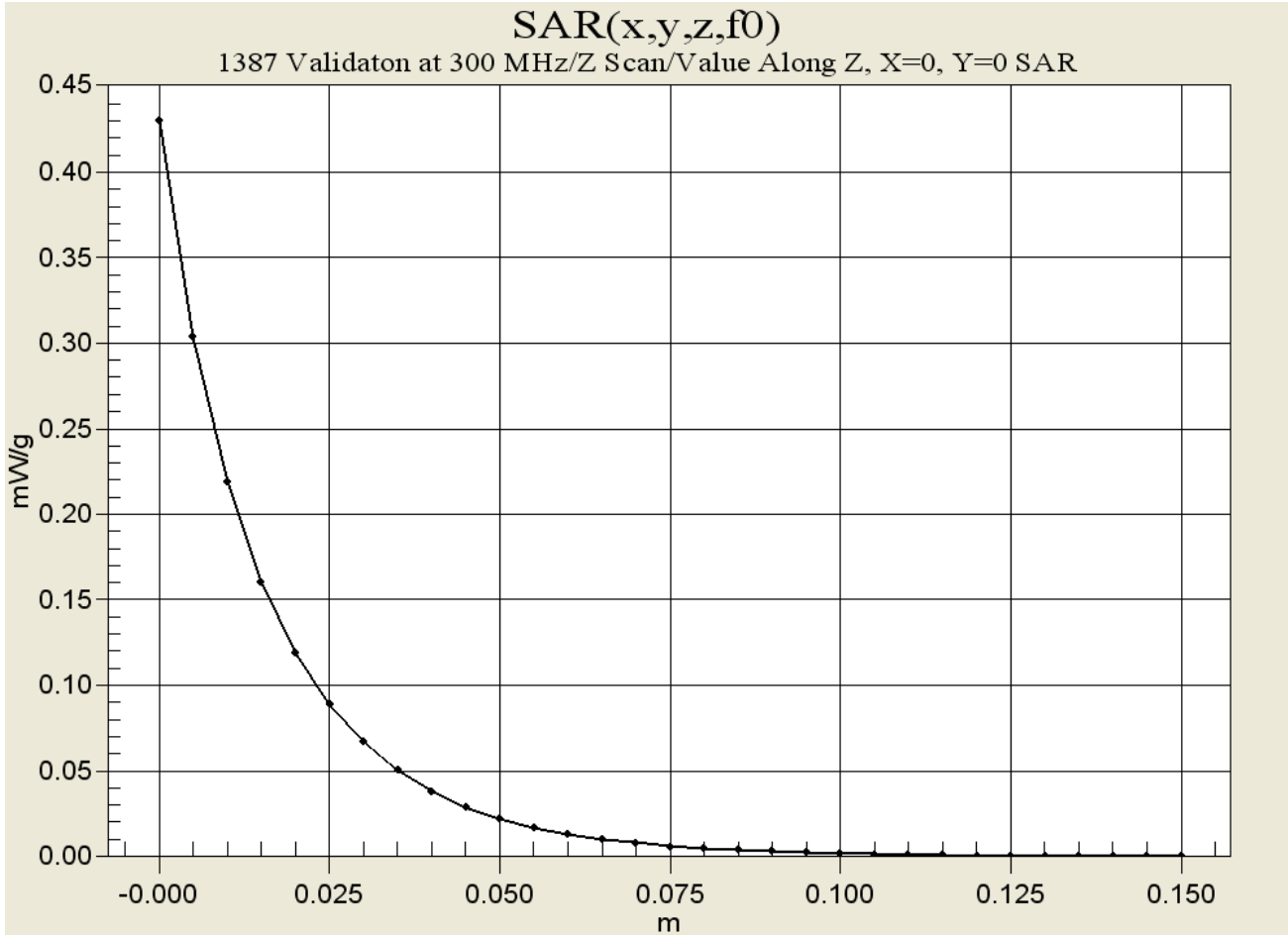

Test Report S/N:	102803-441K66
Test Date(s):	November 07, 2003
Test Type:	FCC/IC SAR Evaluation

## APPENDIX C - SYSTEM VALIDATION

## 300MHz SYSTEM VALIDATION DIPOLE

Type:

**300MHz Validation Dipole**

Serial Number:

**135**

Place of Calibration:

**Celltech Labs Inc.**

Date of Calibration:

**October 30, 2003**

Celltech Labs Inc. hereby certifies that this device has been calibrated on the date indicated above.

Calibrated by:

*Spencer Watson*

Approved by:

*Russell W. Pipe*

## 1. Validation Dipole Construction & Electrical Characteristics

The validation dipole was constructed in accordance with the IEEE Std. "Recommended Practice for Determining the Spatial-Peak Specific Absorption Rate (SAR) in the Human Body Due to Wireless Communications Devices: Experimental Techniques". The electrical properties were measured using an HP 8753E Network Analyzer. The network analyzer was calibrated to the validation dipole N-type connector feed point using an HP85032E Type N calibration kit. The dipole was placed parallel to a planar phantom at a separation distance of 15.0mm from the simulating fluid using a loss-less dielectric spacer. The measured input impedance is:

Feed point impedance at 300MHz	$\text{Re}\{Z\} = 43.586\Omega$
	$\text{Im}\{Z\} = -4.5313\Omega$
Return Loss at 300MHz	-21.693dB

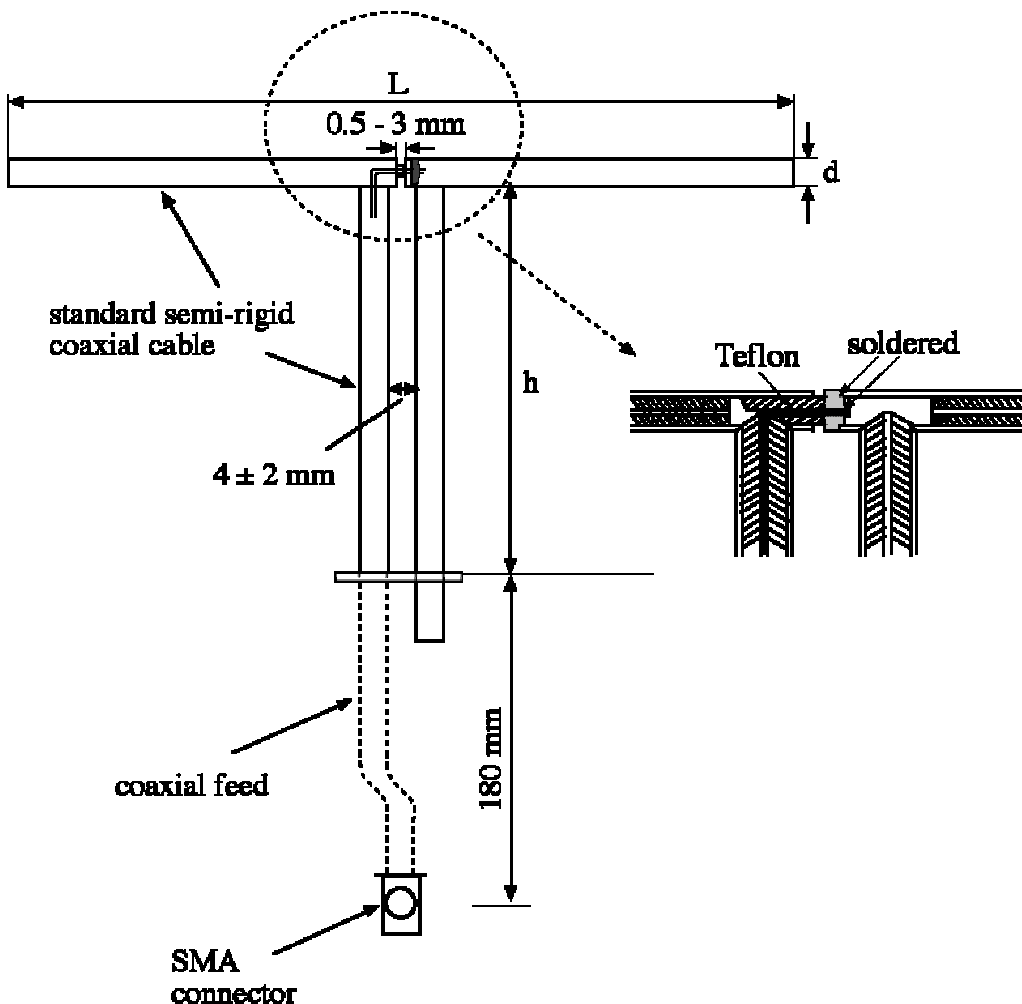

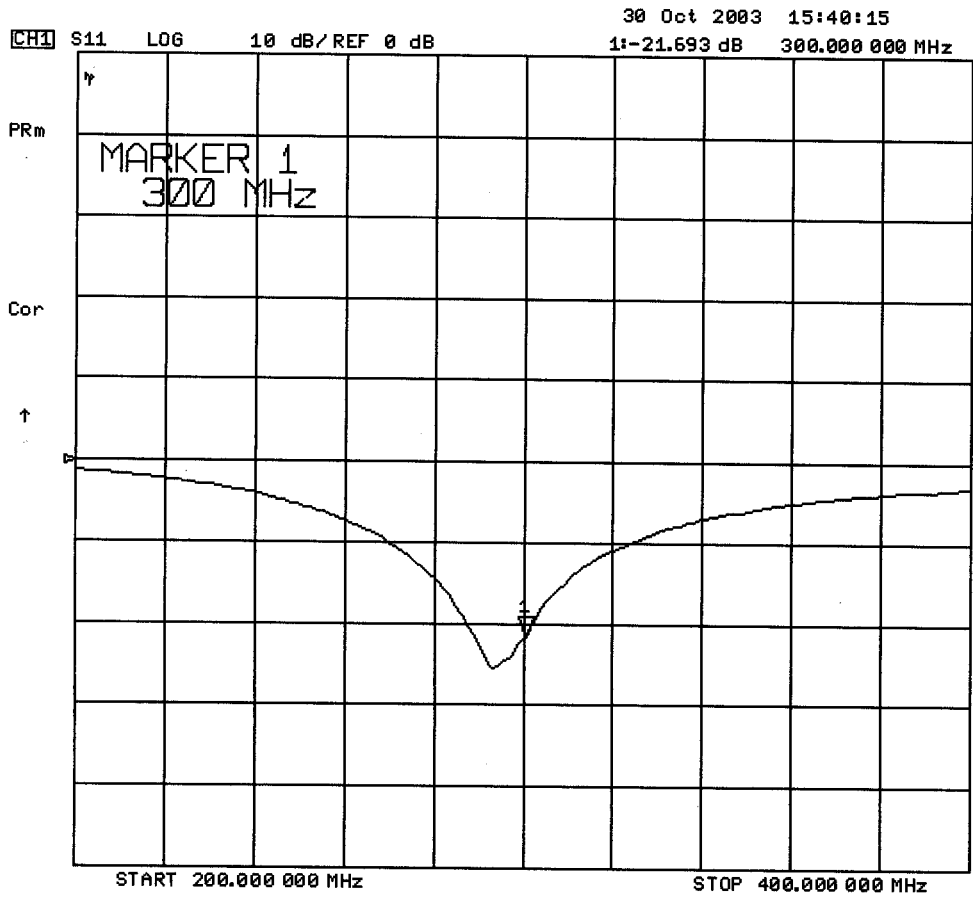

30 Oct 2003 15:41:51  
[CH1] S11 1 U FS 1: 43.586  $\Omega$  -4.5313  $\Omega$  117.08 pF 300.000 000 MHz

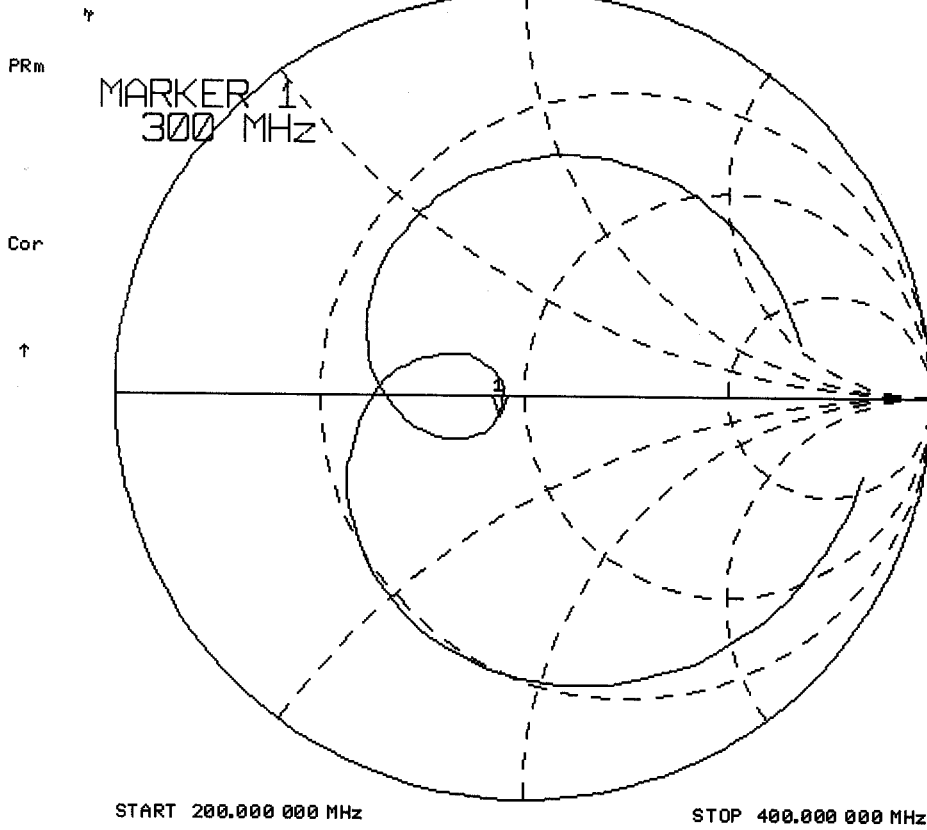

## 2. Validation Dipole Dimensions

Frequency (MHz)	L (mm)	H (mm)	D (mm)
300	420.0	250.0	6.2
450	288.0	167.0	6.2
835	161.0	89.8	3.6
900	149.0	83.3	3.6
1450	89.1	51.7	3.6
1800	72.0	41.7	3.6
1900	68.0	39.5	3.6
2000	64.5	37.5	3.6
2450	51.8	30.6	3.6
3000	41.5	25.0	3.6

## 3. Validation Phantom

The validation phantom was constructed using relatively low-loss tangent Plexiglas material. The inner dimensions of the phantom are as follows:

Length: 83.5 cm

Width: 36.9 cm

Height: 21.8 cm

The bottom section of the validation phantom is constructed of  $6.2 \pm 0.1$ mm Plexiglas.



#### 4. Dimensions of Plexiglas Planar Phantom

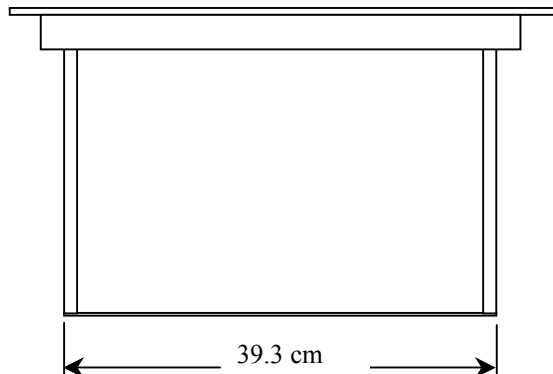
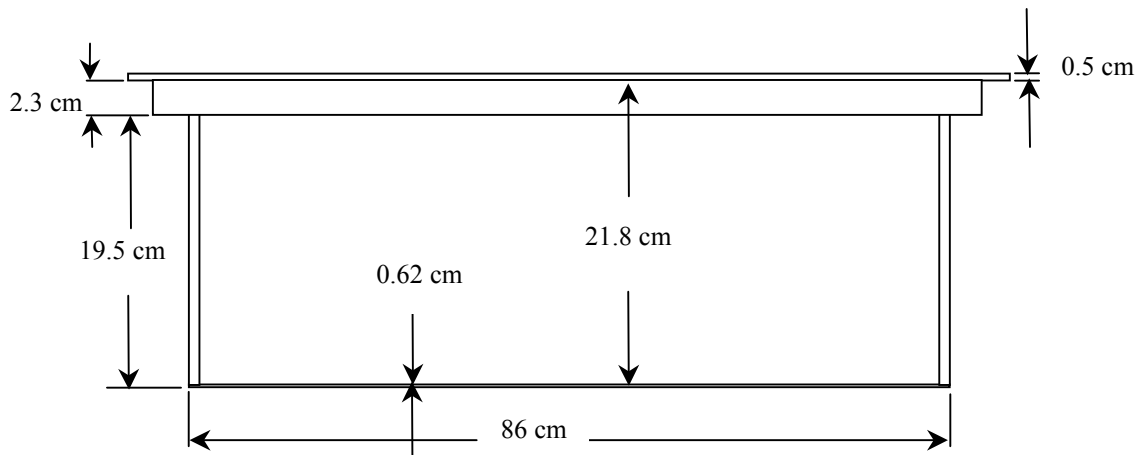
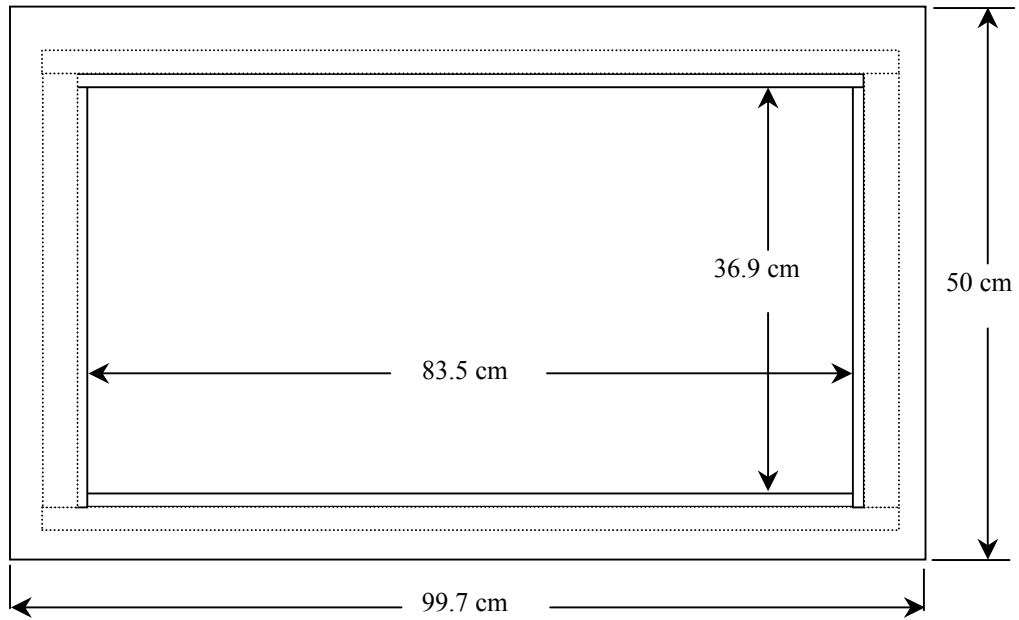

**5. 300MHz System Validation Setup**

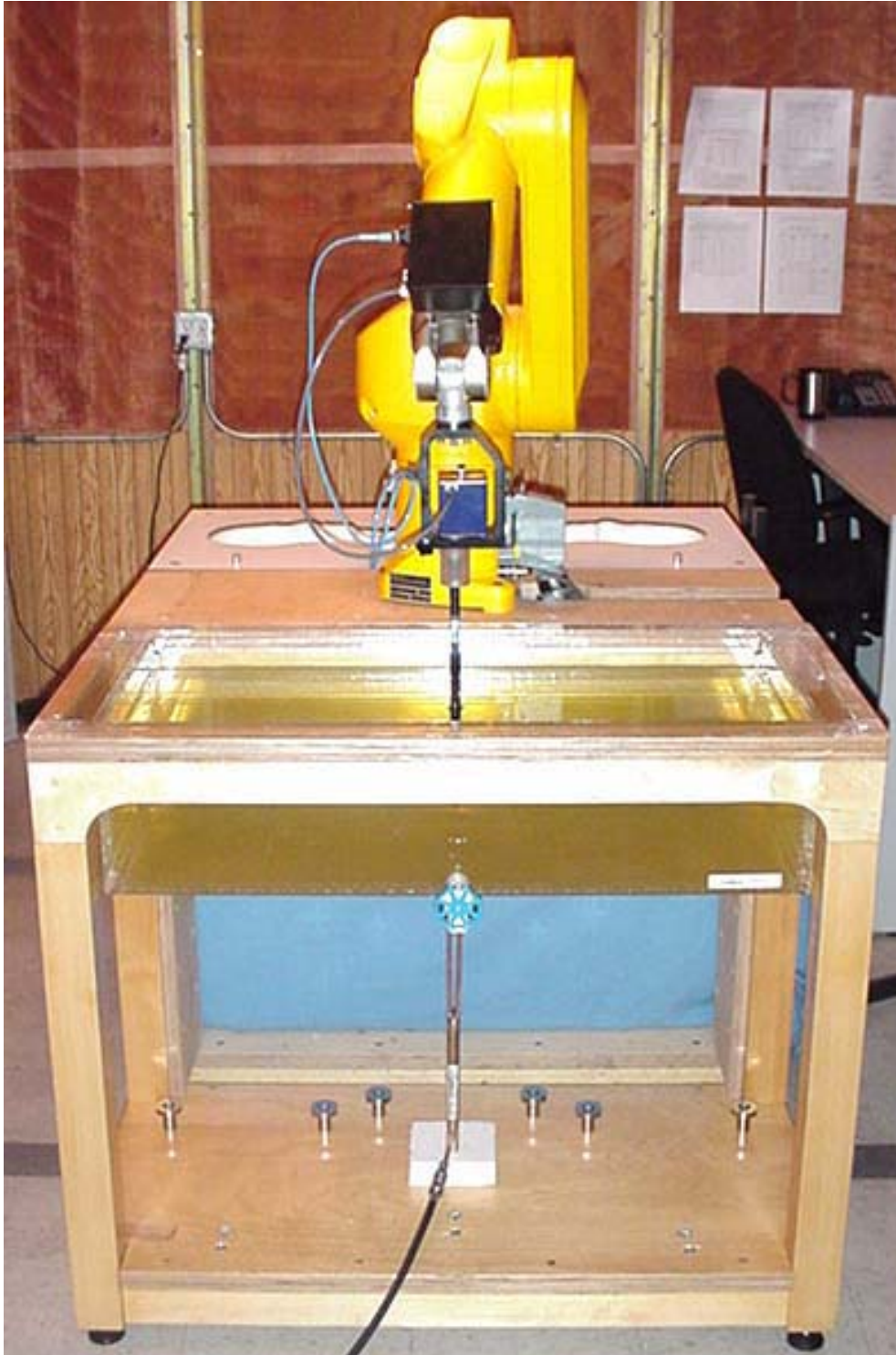

**300MHz System Validation Setup**



## 6. Measurement Conditions

The planar phantom was filled with simulated brain tissue having the following parameters at 300MHz:

Relative Permittivity:	45.7
Conductivity:	0.88 mho/m
Fluid Temperature:	22.2°C
Fluid Depth:	≥ 15cm

Environmental Conditions:

Ambient Temperature:	22.1°C
Humidity:	56%
Barometric Pressure:	103.4 kPa

The 300MHz simulated tissue mixture consists of the following ingredients:

<b>Ingredient</b>	<b>Percentage by weight</b>
Water	37.56%
Sugar	55.32%
Salt	5.95%
HEC	0.98%
Dowicil 75	0.19%
300MHz Target Dielectric Parameters at 22°C	$\epsilon_r = 45.3$ $\sigma = 0.87 \text{ S/m}$

## 7. SAR Measurement

The SAR measurement was performed with the E-field probe in mechanical detection mode only. The setup and determination of the forward power into the dipole was performed using the following procedures.

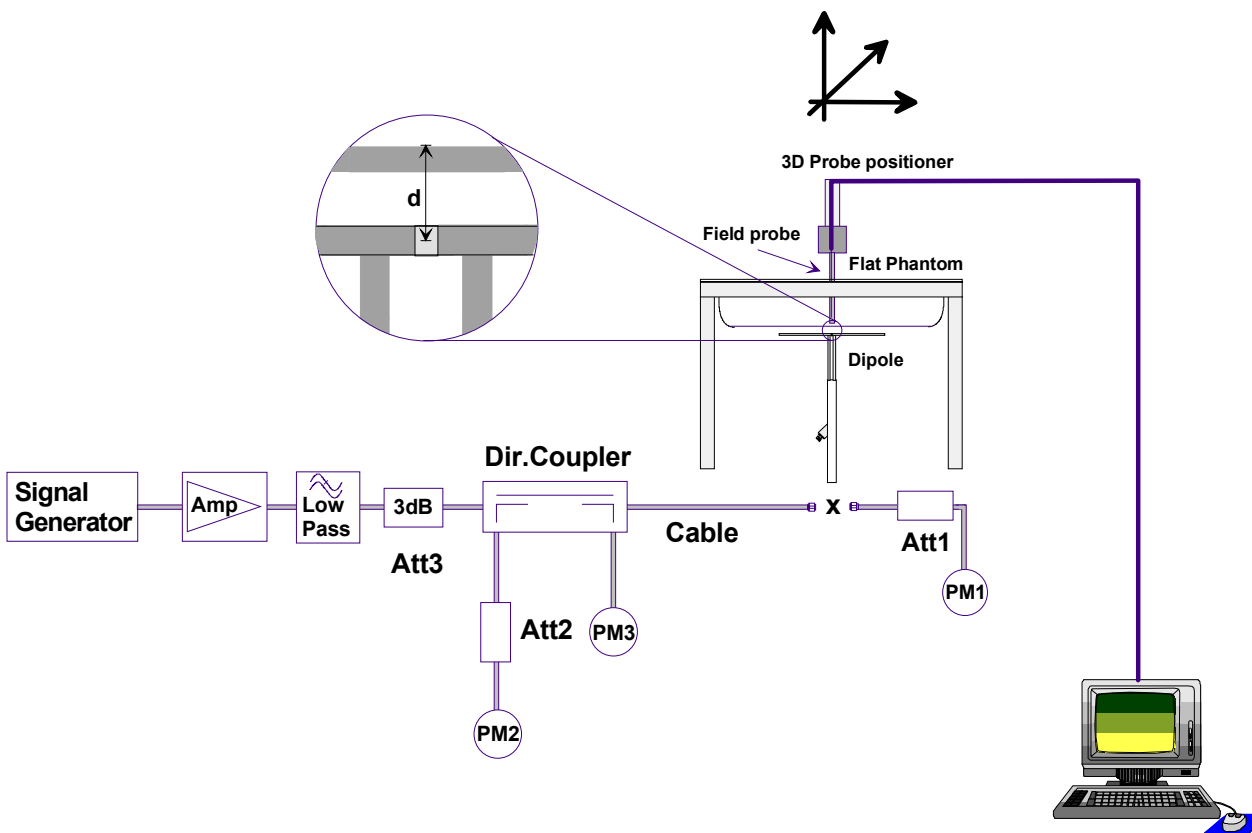

First the power meter PM1 (including attenuator Att1) is connected to the cable to measure the forward power at the location of the dipole connector (X). The signal generator is adjusted for the desired forward power at the dipole connector (taking into account the attenuation of Att1) as read by power meter PM2. After connecting the cable to the dipole, the signal generator is readjusted for the same reading at power meter PM2. If the signal generator does not allow adjustment in 0.01dB steps, the remaining difference at PM2 must be taken into consideration. PM3 records the reflected power from the dipole to ensure that the value is not changed from the previous value. The reflected power should be 20dB below the forward power.

## 8. Validation Dipole SAR Test Results

Ten SAR measurements were performed in order to achieve repeatability and to establish an average target value.

Validation Measurement	SAR @ 0.25W Input averaged over 1g	SAR @ 1W Input averaged over 1g	SAR @ 0.25W Input averaged over 10g	SAR @ 1W Input averaged over 10g	Peak SAR @ 0.25W Input
Test 1	0.781	3.12	0.497	1.99	1.39
Test 2	0.779	3.12	0.495	1.98	1.39
Test 3	0.780	3.12	0.496	1.98	1.38
Test 4	0.788	3.15	0.501	2.00	1.41
Test 5	0.787	3.15	0.498	1.99	1.39
Test 6	0.780	3.12	0.492	1.97	1.38
Test 7	0.776	3.10	0.494	1.98	1.37
Test 8	0.784	3.14	0.500	2.00	1.39
Test 9	0.785	3.14	0.500	2.00	1.39
Test 10	0.784	3.14	0.496	1.98	1.40
Average Value	0.782	3.13	0.497	1.99	1.39

The results have been normalized to 1W (forward power) into the dipole.

IEEE Target over 1cm<sup>3</sup> (1g) of tissue: 0.750 mW/g (+/- 10%)

Averaged over 1cm<sup>3</sup> (1g) of tissue: 3.13 mW/g

Averaged over 10cm<sup>3</sup> (10g) of tissue: 1.99 mW/g

Test Date: 10/30/03

DUT: Dipole 300 MHz; Model: D300V2; Type: System Validation; Serial: 135

Ambient Temp: 22.1°C; Fluid Temp: 22.2°C; Barometric Pressure: 103.4 kPa; Humidity: 56%

Communication System: CW  
Forward Conducted Power: 250 mW  
Frequency: 300 MHz; Duty Cycle: 1:1  
Medium: 300 HSL ( $\sigma = 0.88$  mho/m,  $\epsilon_r = 45.7$ ,  $\rho = 1000$  kg/m<sup>3</sup>)

- Probe: ET3DV6 - SN1387; ConvF(7.9, 7.9, 7.9); Calibrated: 26/02/2003
- Sensor-Surface: 4mm (Mechanical Surface Detection)
- Electronics: DAE3 Sn370; Calibrated: 19/05/2003
- Phantom: Validation Planar; Type: Plexiglas; Serial: 137
- Measurement SW: DASY4, V4.1 Build 47; Postprocessing SW: SEMCAD, V1.6 Build 116

**300 MHz Validation/Area Scan (6x11x1):** Measurement grid: dx=15mm, dy=15mm  
Reference Value = 30.4 V/m  
Power Drift = -0.1 dB

**300 MHz Validation/Zoom Scan (7x7x7)/Cube 0:** Measurement grid: dx=5mm, dy=5mm, dz=5mm  
Peak SAR (extrapolated) = 1.39 W/kg  
**SAR(1 g) = 0.781 mW/g; SAR(10 g) = 0.497 mW/g**  
Reference Value = 30.4 V/m  
Power Drift = -0.1 dB

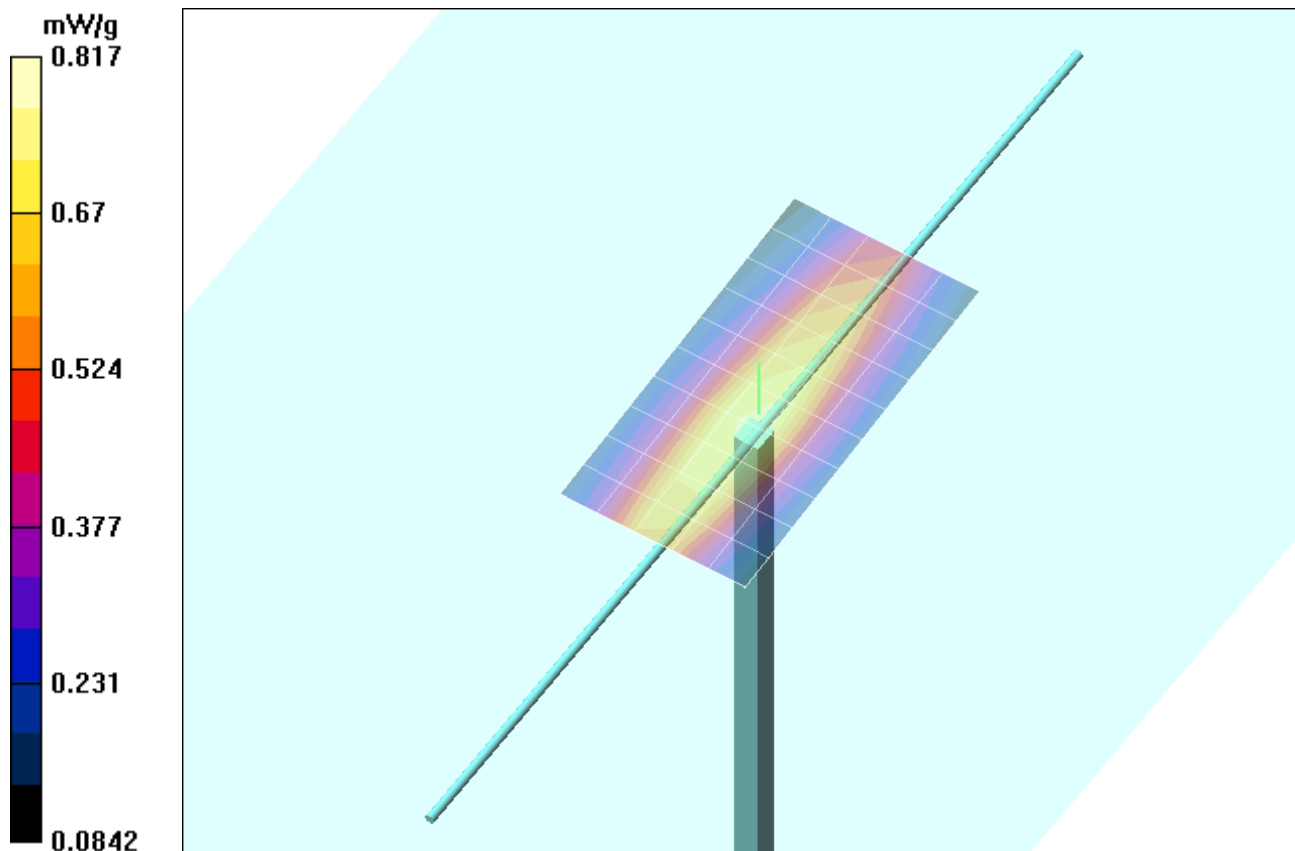

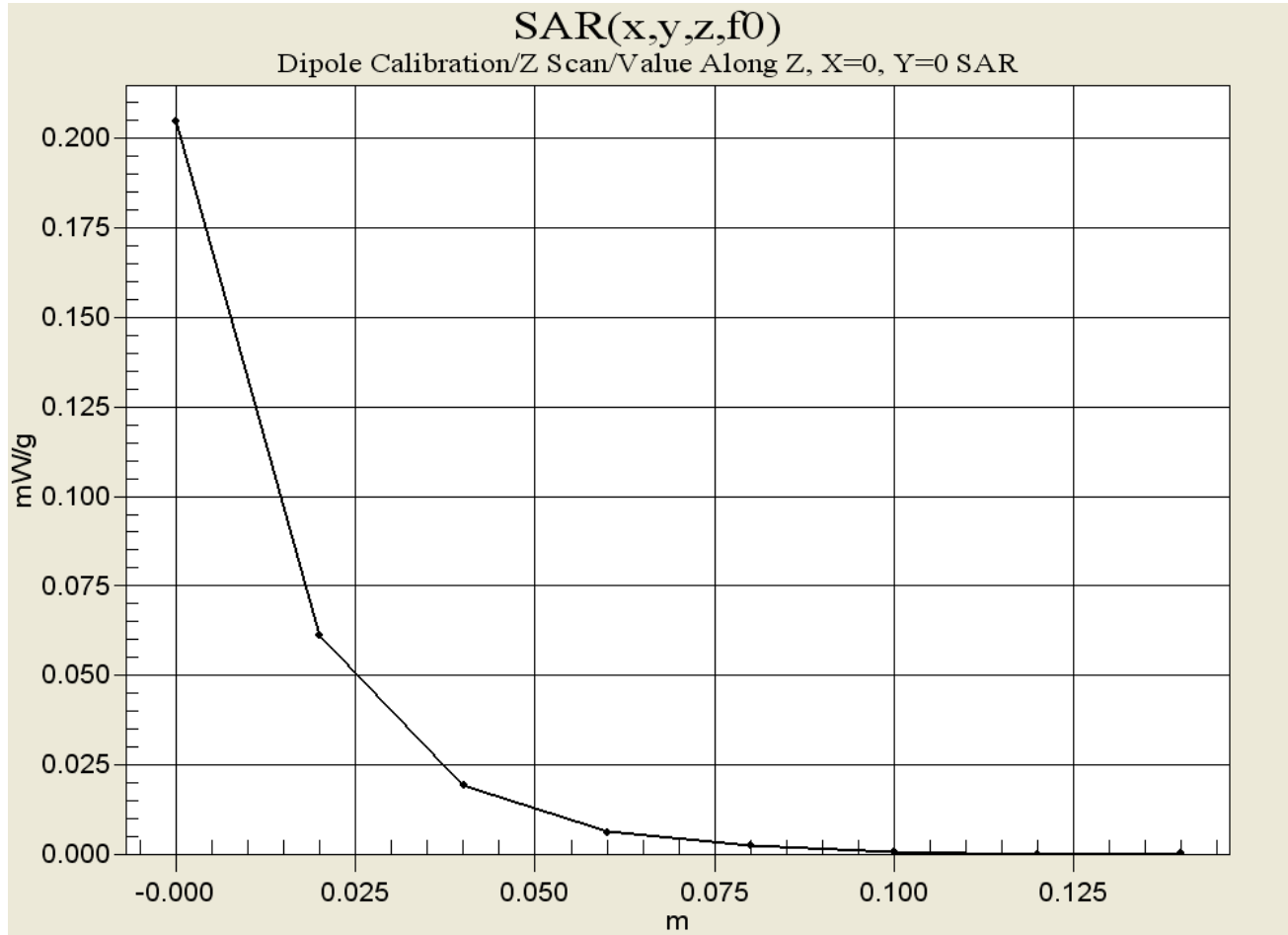



# 300MHz System Validation

## Measured Fluid Dielectric Parameters (Brain)

October 30, 2003

Frequency	$\epsilon'$	$\epsilon''$
200.000000 MHz	49.8336	71.7361
210.000000 MHz	49.2398	69.1403
220.000000 MHz	48.9026	66.6656
230.000000 MHz	48.4363	64.3972
240.000000 MHz	47.9018	62.2373
250.000000 MHz	47.4646	60.4416
260.000000 MHz	47.0839	58.8112
270.000000 MHz	46.6772	57.3352
280.000000 MHz	46.4143	55.8759
290.000000 MHz	46.0204	54.5734
300.000000 MHz	45.6863	52.9882
310.000000 MHz	45.3261	51.7924
320.000000 MHz	44.9882	50.6430
330.000000 MHz	44.6549	49.5121
340.000000 MHz	44.3168	48.5356
350.000000 MHz	44.0824	47.5910
360.000000 MHz	43.7780	46.7661
370.000000 MHz	43.5461	45.8627
380.000000 MHz	43.3671	45.0444
390.000000 MHz	43.1052	44.2129
400.000000 MHz	42.8360	43.5735

Test Report S/N:	102803-441K66
Test Date(s):	November 07, 2003
Test Type:	FCC/IC SAR Evaluation

## APPENDIX D - PROBE CALIBRATION

Client **Celltech Labs**

**CALIBRATION CERTIFICATE**

Object(s) **ET3DV6 - SN: 1387**

Calibration procedure(s) **QA CAL-01.v2  
Calibration procedure for dosimetric E-field probes**

Calibration date: **February 26, 2003**

Condition of the calibrated item **In Tolerance (according to the specific calibration document)**

This calibration statement documents traceability of M&TE used in the calibration procedures and conformity of the procedures with the ISO/IEC 17025 international standard.

All calibrations have been conducted in the closed laboratory facility: environment temperature 22 +/- 2 degrees Celsius and humidity < 75%.

Calibration Equipment used (M&TE critical for calibration)

Model Type	ID #	Cal Date	Scheduled Calibration
RF generator HP 8684C	US3642U01700	4-Aug-99 (in house check Aug-02)	In house check: Aug-05
Power sensor E4412A	MY41495277	8-Mar-02	Mar-03
Power sensor HP 8481A	MY41092180	18-Sep-02	Sep-03
Power meter EPM E4419B	GB41293874	13-Sep-02	Sep-03
Network Analyzer HP 8753E	US38432426	3-May-00	In house check: May 03
Fluke Process Calibrator Type 702	SN: 6295803	3-Sep-01	Sep-03

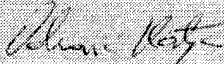
	Name	Function	Signature
Calibrated by:	Nico Vetterli	Technician	
Approved by:	Katja Pokovic	Laboratory Director	

Date issued: February 26, 2003

This calibration certificate is issued as an intermediate solution until the accreditation process (based on ISO/IEC 17025 International Standard) for Calibration Laboratory of Schmid & Partner Engineering AG is completed.

# Probe ET3DV6

## SN:1387

Manufactured:	September 21, 1999
Last calibration:	February 22, 2002
Recalibrated:	February 26, 2003

**Calibrated for DASYS Systems**

(Note: non-compatible with DASYS2 system!)

## DASY - Parameters of Probe: ET3DV6 SN:1387

### Sensitivity in Free Space

NormX	<b>1.55</b> $\mu\text{V}/(\text{V}/\text{m})^2$
NormY	<b>1.65</b> $\mu\text{V}/(\text{V}/\text{m})^2$
NormZ	<b>1.64</b> $\mu\text{V}/(\text{V}/\text{m})^2$

### Diode Compression

DCP X	<b>92</b>	mV
DCP Y	<b>92</b>	mV
DCP Z	<b>92</b>	mV

### Sensitivity in Tissue Simulating Liquid

<b>Head</b>	<b>900 MHz</b>	$\epsilon_r = 41.5 \pm 5\%$	$\sigma = 0.97 \pm 5\% \text{ mho/m}$
<b>Head</b>	<b>835 MHz</b>	$\epsilon_r = 41.5 \pm 5\%$	$\sigma = 0.90 \pm 5\% \text{ mho/m}$
ConvF X	<b>6.6</b> $\pm 9.5\%$ (k=2)	Boundary effect:	
ConvF Y	<b>6.6</b> $\pm 9.5\%$ (k=2)	Alpha	<b>0.37</b>
ConvF Z	<b>6.6</b> $\pm 9.5\%$ (k=2)	Depth	<b>2.61</b>
<b>Head</b>	<b>1800 MHz</b>	$\epsilon_r = 40.0 \pm 5\%$	$\sigma = 1.40 \pm 5\% \text{ mho/m}$
<b>Head</b>	<b>1900 MHz</b>	$\epsilon_r = 40.0 \pm 5\%$	$\sigma = 1.40 \pm 5\% \text{ mho/m}$
ConvF X	<b>5.2</b> $\pm 9.5\%$ (k=2)	Boundary effect:	
ConvF Y	<b>5.2</b> $\pm 9.5\%$ (k=2)	Alpha	<b>0.50</b>
ConvF Z	<b>5.2</b> $\pm 9.5\%$ (k=2)	Depth	<b>2.73</b>

### Boundary Effect

<b>Head</b>	<b>900 MHz</b>	<b>Typical SAR gradient: 5 % per mm</b>	
Probe Tip to Boundary		<b>1 mm</b>	<b>2 mm</b>
SAR <sub>be</sub> [%]	Without Correction Algorithm	10.2	5.9
SAR <sub>be</sub> [%]	With Correction Algorithm	0.4	0.6
<b>Head</b>	<b>1800 MHz</b>	<b>Typical SAR gradient: 10 % per mm</b>	
Probe Tip to Boundary		<b>1 mm</b>	<b>2 mm</b>
SAR <sub>be</sub> [%]	Without Correction Algorithm	14.6	9.8
SAR <sub>be</sub> [%]	With Correction Algorithm	0.2	0.0

### Sensor Offset

Probe Tip to Sensor Center	<b>2.7</b>	mm
Optical Surface Detection	<b>1.4 <math>\pm</math> 0.2</b>	mm

### Receiving Pattern ( $\phi$ ), $\theta = 0^\circ$

**f = 30 MHz, TEM cell ifi110**

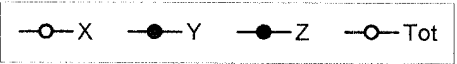
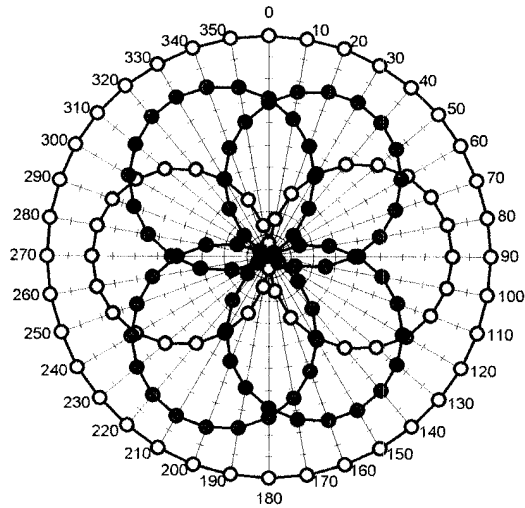

**f = 100 MHz, TEM cell ifi110**

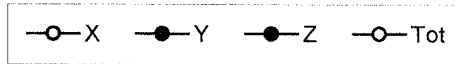
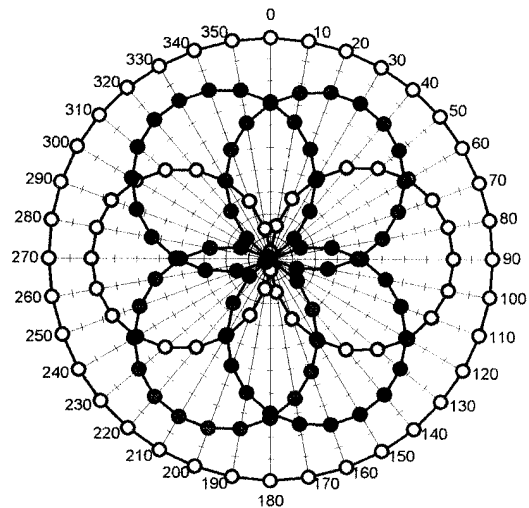

**f = 300 MHz, TEM cell ifi110**

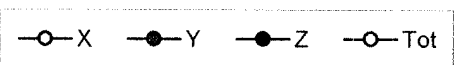
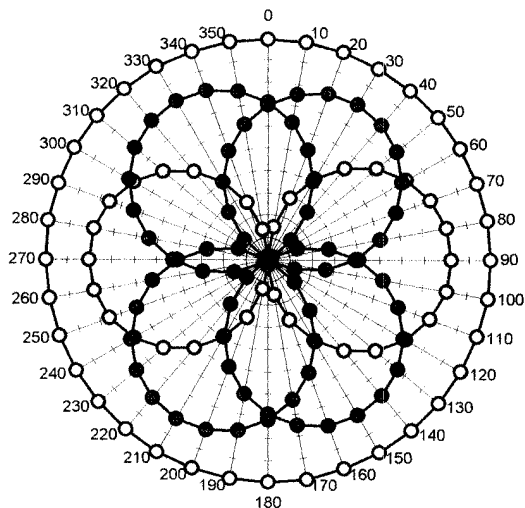

**f = 900 MHz, TEM cell ifi110**

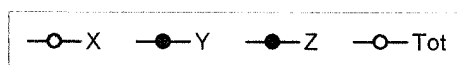
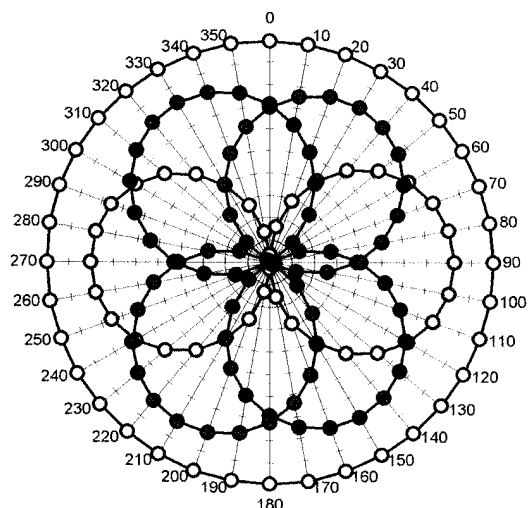

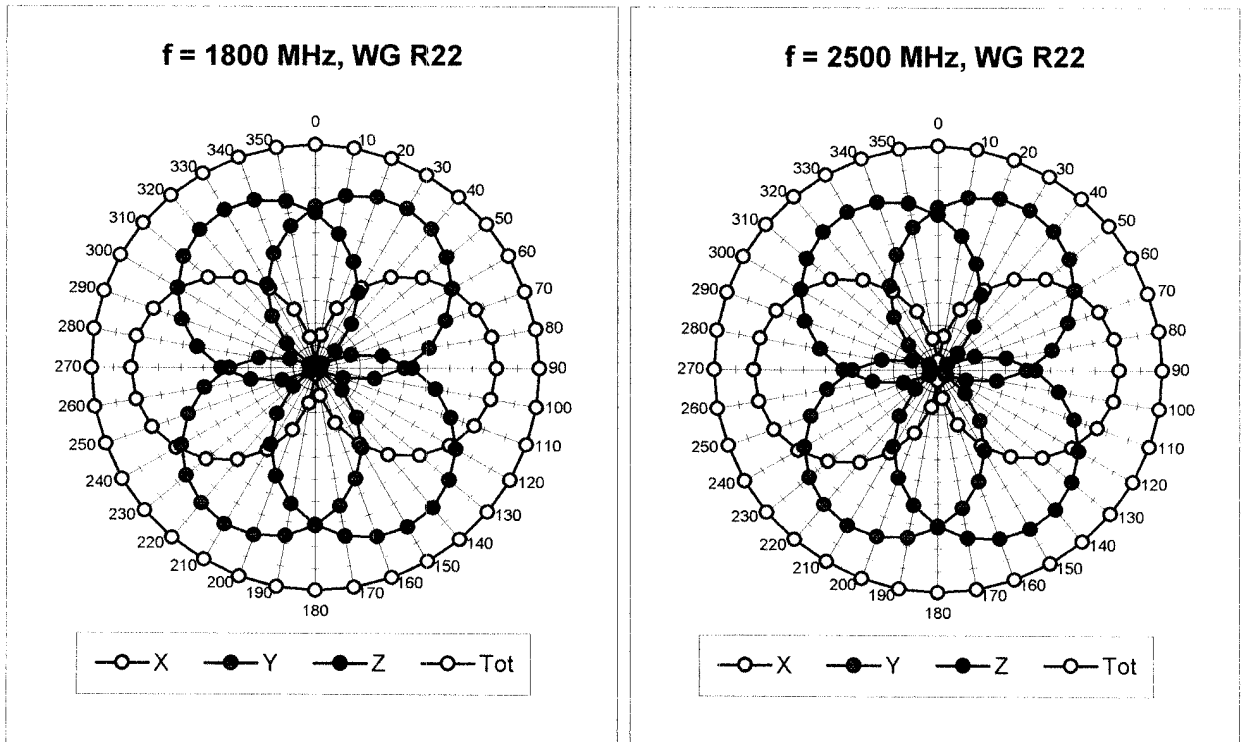

### Isotropy Error ( $\phi$ ), $\theta = 0^\circ$

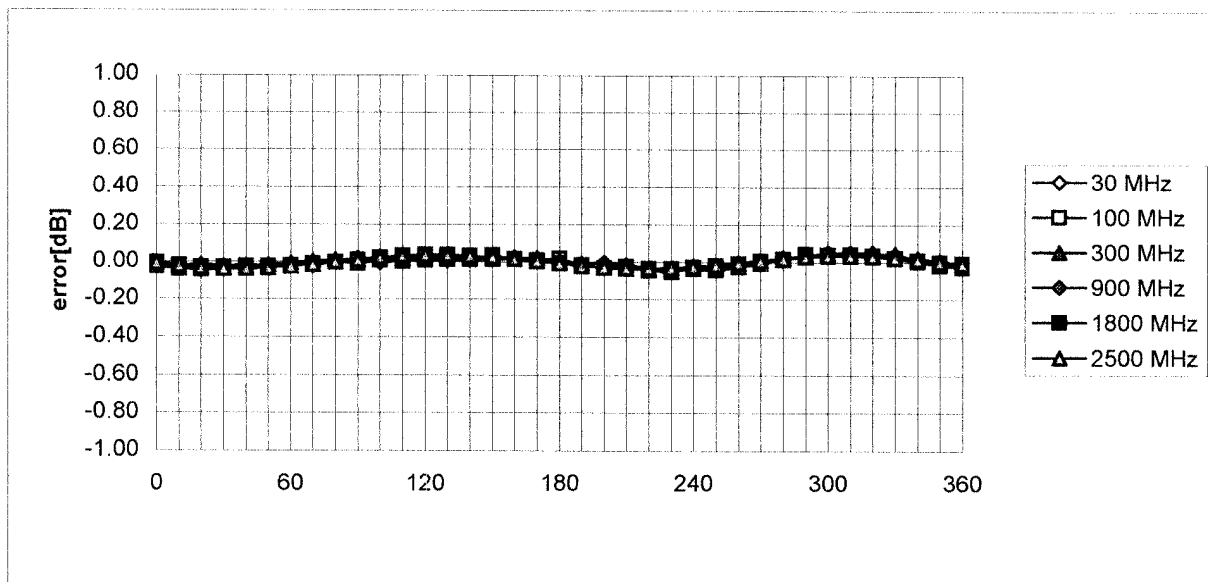

# Frequency Response of E-Field

( TEM-Cell:ifi110, Waveguide R22)

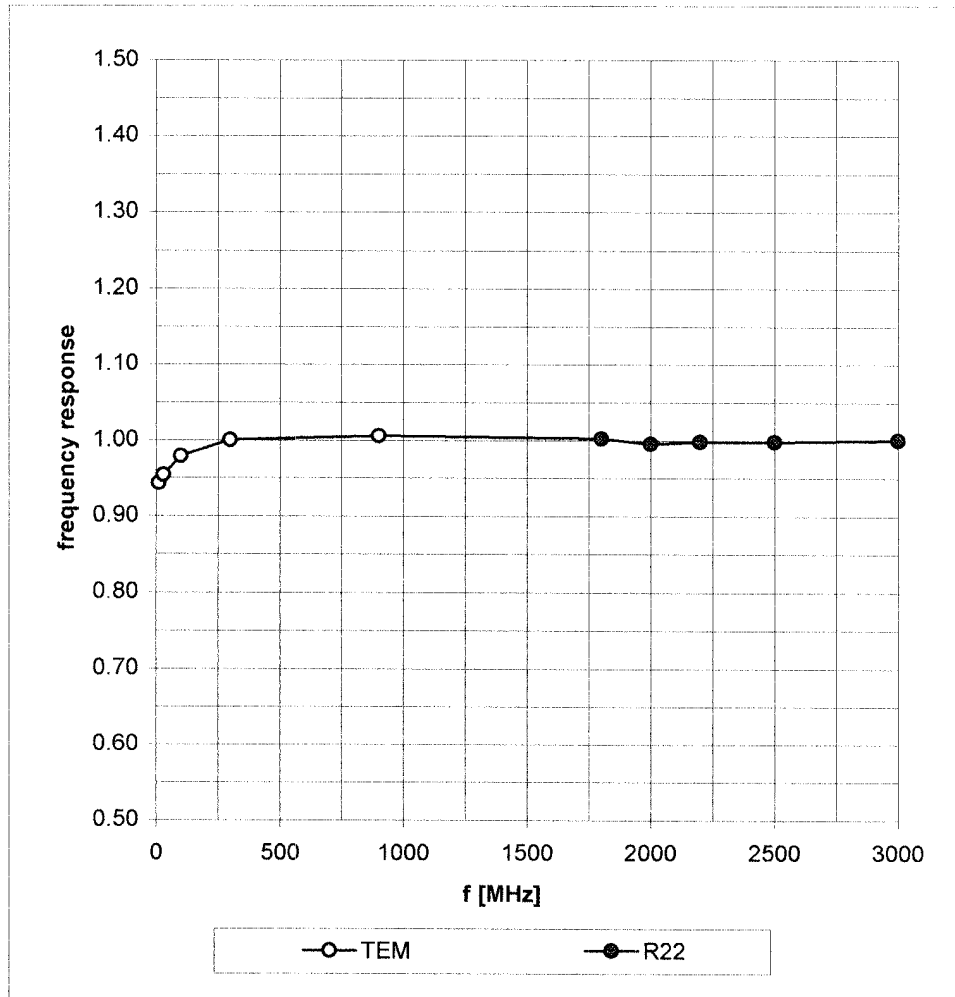



### Dynamic Range f(SAR<sub>brain</sub>) ( Waveguide R22 )

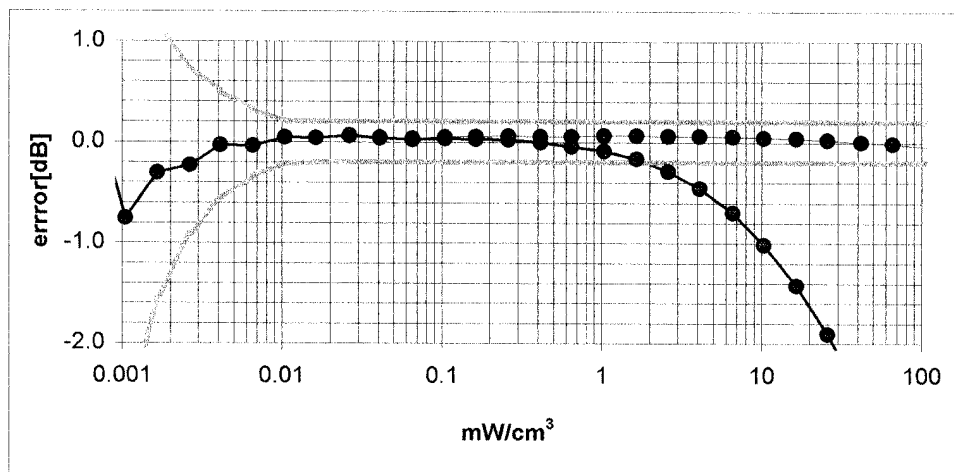
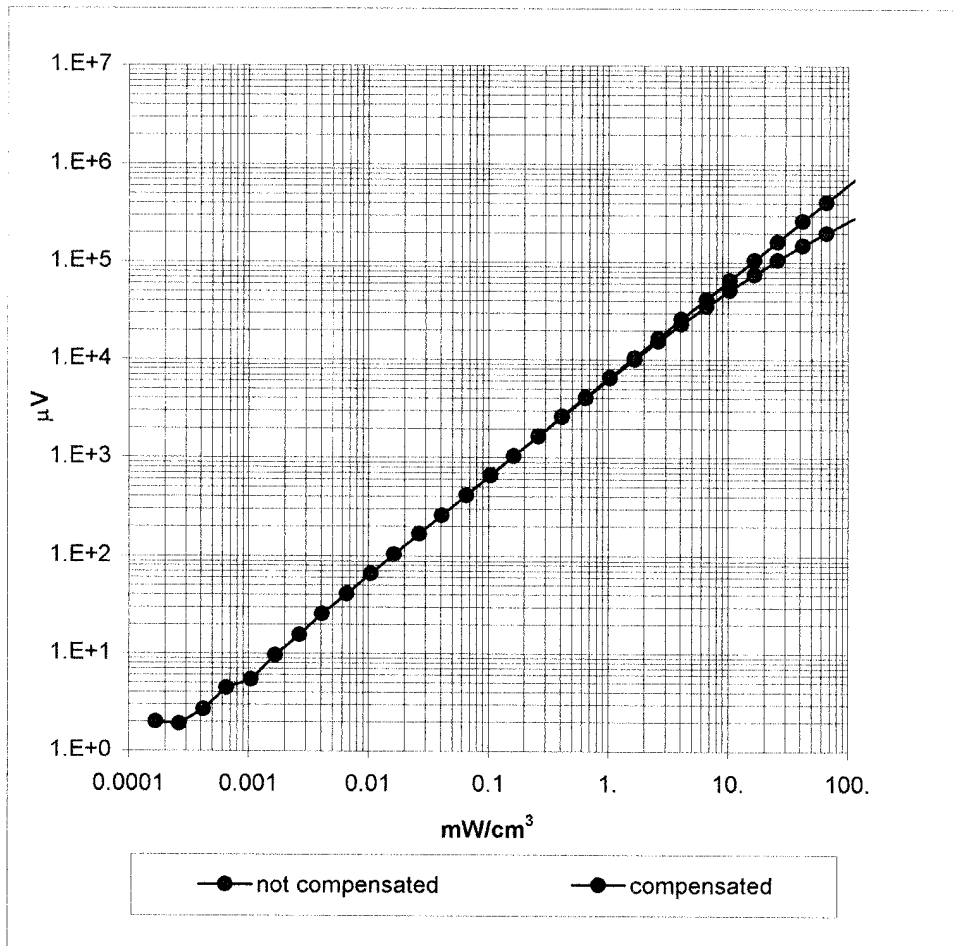

## Conversion Factor Assessment

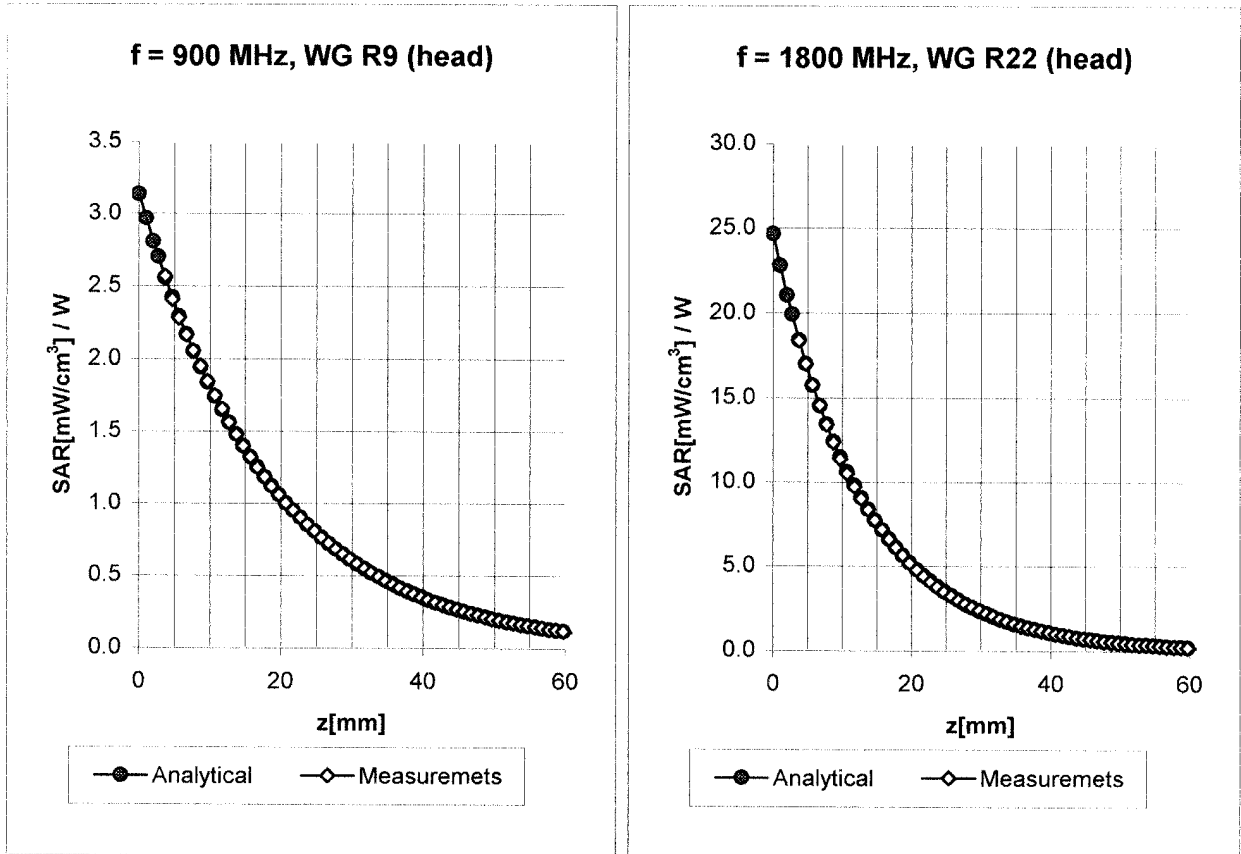

<b>Head</b>	<b>900 MHz</b>	$\epsilon_r = 41.5 \pm 5\%$	$\sigma = 0.97 \pm 5\% \text{ mho/m}$
<b>Head</b>	<b>835 MHz</b>	$\epsilon_r = 41.5 \pm 5\%$	$\sigma = 0.90 \pm 5\% \text{ mho/m}$
	ConvF X	<b>6.6</b> $\pm 9.5\%$ (k=2)	Boundary effect:
	ConvF Y	<b>6.6</b> $\pm 9.5\%$ (k=2)	Alpha <b>0.37</b>
	ConvF Z	<b>6.6</b> $\pm 9.5\%$ (k=2)	Depth <b>2.61</b>
<b>Head</b>	<b>1800 MHz</b>	$\epsilon_r = 40.0 \pm 5\%$	$\sigma = 1.40 \pm 5\% \text{ mho/m}$
<b>Head</b>	<b>1900 MHz</b>	$\epsilon_r = 40.0 \pm 5\%$	$\sigma = 1.40 \pm 5\% \text{ mho/m}$
	ConvF X	<b>5.2</b> $\pm 9.5\%$ (k=2)	Boundary effect:
	ConvF Y	<b>5.2</b> $\pm 9.5\%$ (k=2)	Alpha <b>0.50</b>
	ConvF Z	<b>5.2</b> $\pm 9.5\%$ (k=2)	Depth <b>2.73</b>

## Conversion Factor Assessment

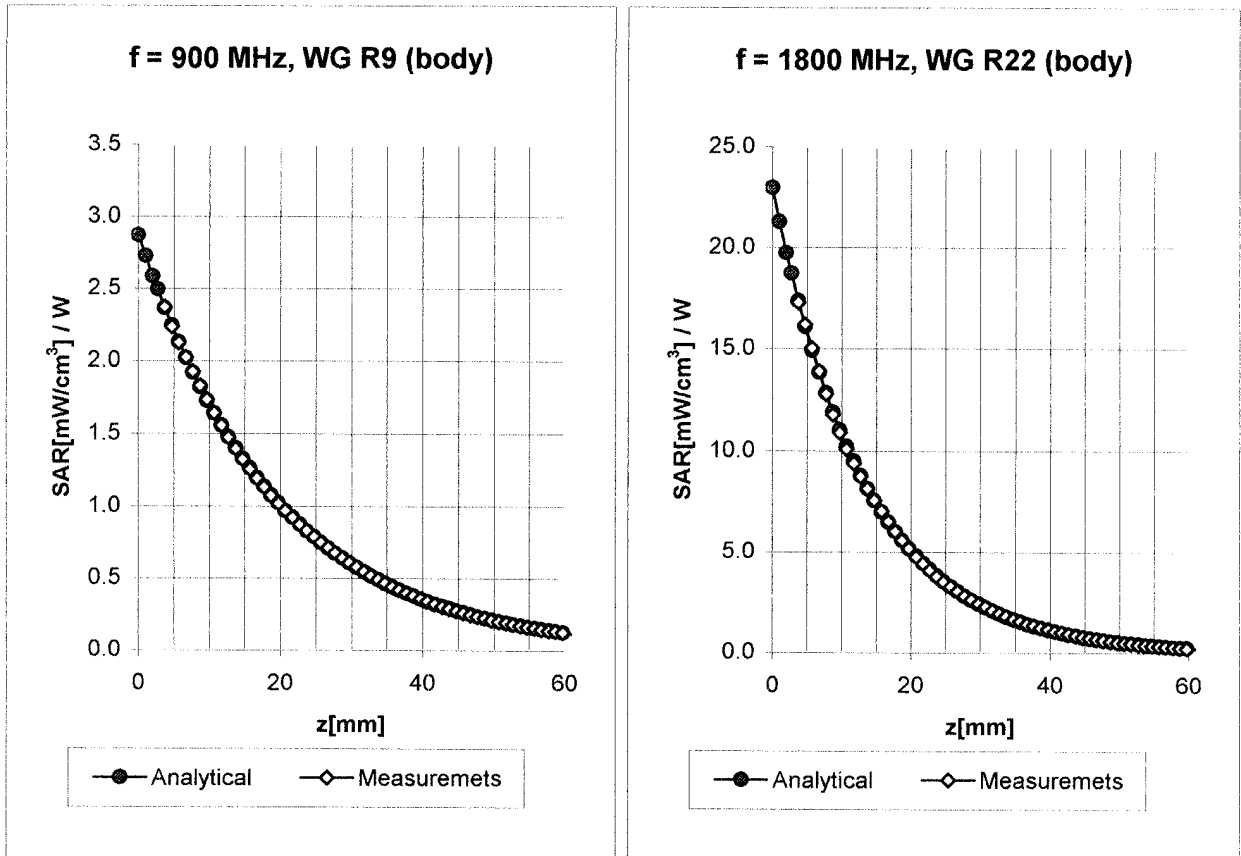

<b>Body</b>	<b>900 MHz</b>	$\epsilon_r = 55.0 \pm 5\%$	$\sigma = 1.05 \pm 5\% \text{ mho/m}$
<b>Body</b>	<b>835 MHz</b>	$\epsilon_r = 55.2 \pm 5\%$	$\sigma = 0.97 \pm 5\% \text{ mho/m}$
	ConvF X	<b>6.4</b> $\pm 9.5\%$ (k=2)	Boundary effect:
	ConvF Y	<b>6.4</b> $\pm 9.5\%$ (k=2)	Alpha <b>0.45</b>
	ConvF Z	<b>6.4</b> $\pm 9.5\%$ (k=2)	Depth <b>2.35</b>
<b>Body</b>	<b>1800 MHz</b>	$\epsilon_r = 53.3 \pm 5\%$	$\sigma = 1.52 \pm 5\% \text{ mho/m}$
<b>Body</b>	<b>1900 MHz</b>	$\epsilon_r = 53.3 \pm 5\%$	$\sigma = 1.52 \pm 5\% \text{ mho/m}$
	ConvF X	<b>4.9</b> $\pm 9.5\%$ (k=2)	Boundary effect:
	ConvF Y	<b>4.9</b> $\pm 9.5\%$ (k=2)	Alpha <b>0.60</b>
	ConvF Z	<b>4.9</b> $\pm 9.5\%$ (k=2)	Depth <b>2.59</b>

## Conversion Factor Assessment

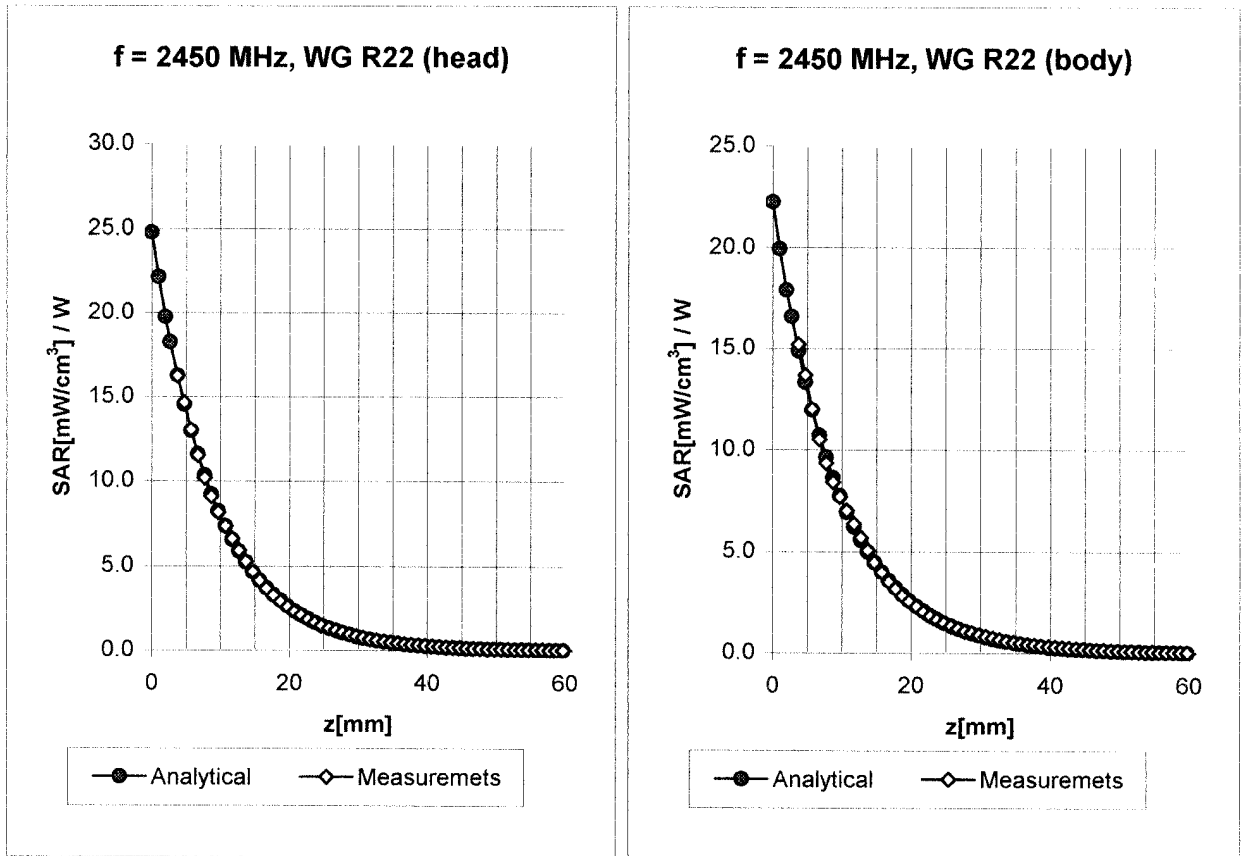

<b>Head</b>	<b>2450</b>	<b>MHz</b>	$\epsilon_r = 39.2 \pm 5\%$	$\sigma = 1.80 \pm 5\% \text{ mho/m}$
	ConvF X	<b>5.0</b>	$\pm 8.9\% (k=2)$	Boundary effect:
	ConvF Y	<b>5.0</b>	$\pm 8.9\% (k=2)$	Alpha <b>1.04</b>
	ConvF Z	<b>5.0</b>	$\pm 8.9\% (k=2)$	Depth <b>1.85</b>
<b>Body</b>	<b>2450</b>	<b>MHz</b>	$\epsilon_r = 52.7 \pm 5\%$	$\sigma = 1.95 \pm 5\% \text{ mho/m}$
	ConvF X	<b>4.6</b>	$\pm 8.9\% (k=2)$	Boundary effect:
	ConvF Y	<b>4.6</b>	$\pm 8.9\% (k=2)$	Alpha <b>1.20</b>
	ConvF Z	<b>4.6</b>	$\pm 8.9\% (k=2)$	Depth <b>1.60</b>

# Deviation from Isotropy in HSL

Error ( $\theta, \phi$ ),  $f = 900$  MHz

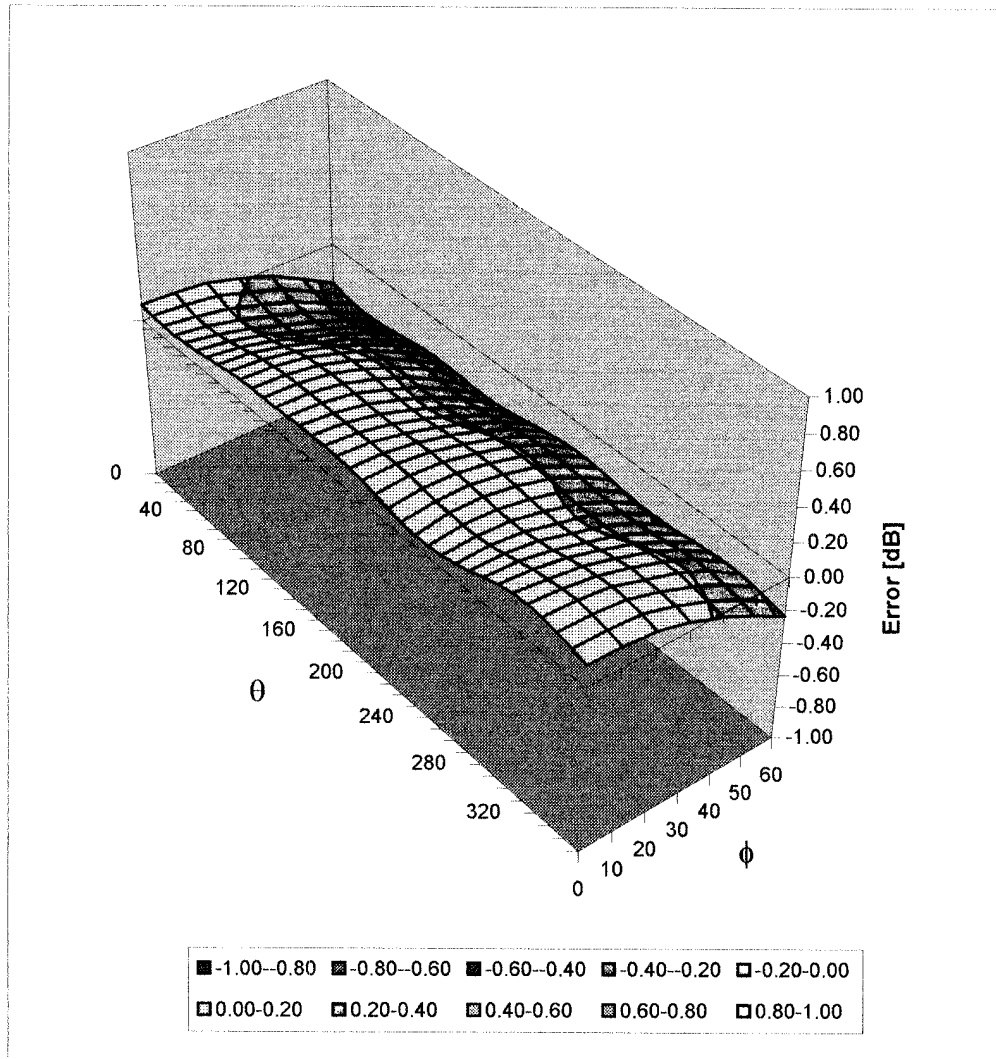

## Additional Conversion Factors for Dosimetric E-Field Probe

Type:	<b>ET3DV6</b>
Serial Number:	<b>1387</b>
Place of Assessment:	<b>Zurich</b>
Date of Assessment:	<b>February 28, 2003</b>
Probe Calibration Date:	<b>February 26, 2003</b>

Schmid & Partner Engineering AG hereby certifies that conversion factor(s) of this probe have been evaluated on the date indicated above. The assessment was performed using the FDTD numerical code SEMCAD of Schmid & Partner Engineering AG. Since the evaluation is coupled with measured conversion factors, it has to be recalculated yearly, i.e., following the re-calibration schedule of the probe. The uncertainty of the numerical assessment is based on the extrapolation from measured value at 900 MHz or at 1800 MHz.

Assessed by:

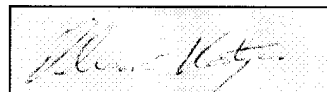

# Dosimetric E-Field Probe ET3DV6 SN:1387

Conversion factor ( $\pm$  standard deviation)

150 MHz	ConvF	$9.1 \pm 8\%$	$\epsilon_r = 52.3$ $\sigma = 0.76 \text{ mho/m}$ (head tissue)
300 MHz	ConvF	$7.9 \pm 8\%$	$\epsilon_r = 45.3$ $\sigma = 0.87 \text{ mho/m}$ (head tissue)
450 MHz	ConvF	$7.5 \pm 8\%$	$\epsilon_r = 43.5$ $\sigma = 0.87 \text{ mho/m}$ (head tissue)
150 MHz	ConvF	$8.8 \pm 8\%$	$\epsilon_r = 61.9$ $\sigma = 0.80 \text{ mho/m}$ (body tissue)
300 MHz	ConvF	$8.0 \pm 8\%$	$\epsilon_r = 58.2$ $\sigma = 0.92 \text{ mho/m}$ (body tissue)
450 MHz	ConvF	$7.7 \pm 8\%$	$\epsilon_r = 56.7$ $\sigma = 0.94 \text{ mho/m}$ (body tissue)

Test Report S/N:	102803-441K66
Test Date(s):	November 07, 2003
Test Type:	FCC/IC SAR Evaluation

## APPENDIX E - MEASURED FLUID DIELECTRIC PARAMETERS



# 300MHz System Performance Check

## Measured Fluid Dielectric Parameters (Brain)

November 07, 2003

Frequency	e'	e''
200.000000 MHz	49.9050	71.8544
210.000000 MHz	49.3900	69.0492
220.000000 MHz	48.9480	66.7559
230.000000 MHz	48.4932	64.4282
240.000000 MHz	48.0502	62.3450
250.000000 MHz	47.5290	60.4189
260.000000 MHz	47.0506	58.7984
270.000000 MHz	46.7002	57.4103
280.000000 MHz	46.4158	55.8907
290.000000 MHz	46.0648	54.5831
300.000000 MHz	45.8029	53.0316
310.000000 MHz	45.4124	51.8370
320.000000 MHz	45.1240	50.6802
330.000000 MHz	44.7631	49.5634
340.000000 MHz	44.4098	48.5866
350.000000 MHz	44.1001	47.6372
360.000000 MHz	43.7969	46.7284
370.000000 MHz	43.5348	45.8641
380.000000 MHz	43.2848	45.0999
390.000000 MHz	43.0064	44.2915
400.000000 MHz	42.7047	43.5485

# 150MHz DUT Evaluation (Face-held)

## Measured Fluid Dielectric Parameters (Brain)

November 07, 2003

Frequency	$\epsilon'$	$\epsilon''$
50.000000 MHz	65.4804	235.8393
60.000000 MHz	62.7326	199.8018
70.000000 MHz	62.3601	172.5951
80.000000 MHz	60.9158	153.1120
90.000000 MHz	59.4439	137.8638
100.000000 MHz	57.8863	125.9516
110.000000 MHz	57.2089	116.0539
120.000000 MHz	55.9485	107.8969
130.000000 MHz	55.3834	100.8010
140.000000 MHz	54.7095	94.8066
150.000000 MHz	54.0286	89.6632
160.000000 MHz	53.2980	85.3181
170.000000 MHz	52.8505	81.4159
180.000000 MHz	52.5310	77.6601
190.000000 MHz	51.9755	74.3779
200.000000 MHz	51.3710	71.5921
210.000000 MHz	50.8312	68.8502
220.000000 MHz	50.4699	66.4922
230.000000 MHz	49.8522	64.2885
240.000000 MHz	49.2866	62.2306
250.000000 MHz	48.8566	60.5422

# 150MHz DUT Evaluation (Body-worn)

## Measured Fluid Dielectric Parameters (Muscle)

November 07, 2003

Frequency	$\epsilon'$	$\epsilon''$
50.000000 MHz	68.9613	256.9659
60.000000 MHz	68.5739	215.8401
70.000000 MHz	67.0475	185.2377
80.000000 MHz	65.8775	164.0370
90.000000 MHz	64.8818	146.3008
100.000000 MHz	63.7786	133.2049
110.000000 MHz	63.1809	122.3806
120.000000 MHz	62.5740	113.6204
130.000000 MHz	62.1539	105.4909
140.000000 MHz	61.7530	98.6839
150.000000 MHz	61.4199	92.8773
160.000000 MHz	61.2141	87.8010
170.000000 MHz	60.7415	83.5256
180.000000 MHz	60.6639	79.3404
190.000000 MHz	60.3575	75.7995
200.000000 MHz	59.9229	72.6171
210.000000 MHz	59.6071	69.8596
220.000000 MHz	59.4078	67.2215
230.000000 MHz	58.9954	64.9732
240.000000 MHz	58.5464	62.8439
250.000000 MHz	58.2697	60.8632

Test Report S/N:	102803-441K66
Test Date(s):	November 07, 2003
Test Type:	FCC/IC SAR Evaluation

## APPENDIX F - SAR TEST SETUP & DUT PHOTOGRAPHS

**FACE-HELD SAR TEST SETUP PHOTOGRAPHS**  
2.5 cm Separation Distance from Front of Radio to Planar Phantom

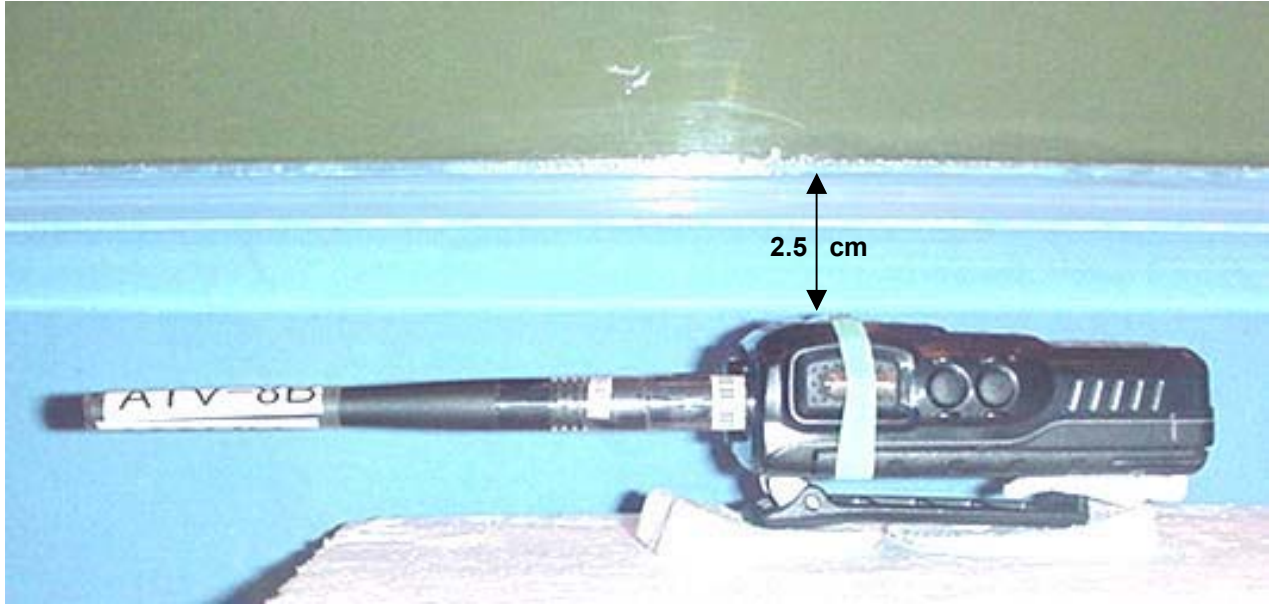

**BODY-WORN SAR TEST SETUP PHOTOGRAPHS**  
1.3 cm Belt-Clip Separation Distance to Planar Phantom  
(with Speaker-Microphone Accessory)

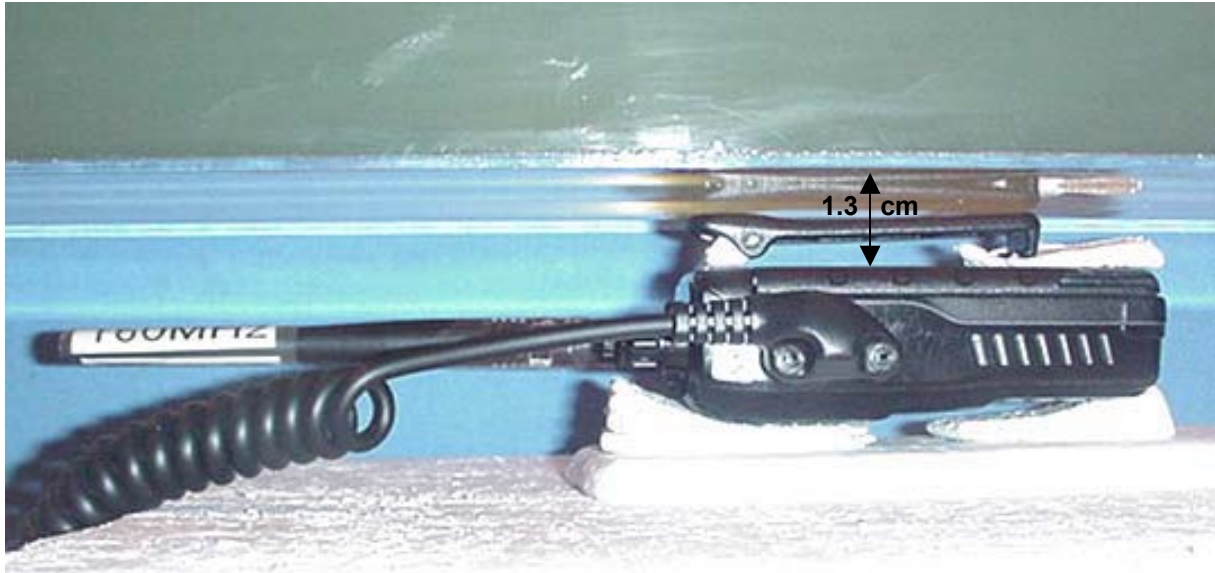

**DUT PHOTOGRAPHS**



with 146 MHz Whip Antenna



with 160 MHz Whip Antenna



with 174 MHz Whip Antenna

**DUT PHOTOGRAPHS**



with 146 MHz Whip Antenna & Speaker Microphone



with 160 MHz Whip Antenna & Speaker Microphone



with 174 MHz Whip Antenna & Speaker Microphone



**DUT PHOTOGRAPHS**



**with Belt-Clip Accessory**



**with Belt-Clip Accessory**

**DUT PHOTOGRAPHS**



**Radio without Battery Pack**



**NiCd Battery Pack**



**NiCd Battery Pack**



**146 MHz Whip Antenna**



**160 MHz Whip Antenna**



**174 MHz Whip Antenna**

**DUT PHOTOGRAPHS**



**Speaker-Microphone**



**Speaker-Microphone**



**Speaker-Microphone**



**Speaker-Microphone**