



CERTIFICATE OF COMPLIANCE

**Regulation : FCC Part 2, 22, 74, 90, 90.210
RSS-119 Issue 6(2000)**

Applicant	Testing Laboratory
VERTEX STANDARD CO.,LTD. 4-8-8 Nakameguro, Meguro-ku, Tokyo 153-8644, Japan Tel.: +81 3 5725 6122 Fax.: +81 3 5725 6225	Akzo Nobel K. K. Kashima No.1 Test site FCC Registration Number : 934283 IC File Number : IC-2065-1 1, Oaza Sunayama, Hasaki-machi, Kashima-gun Ibaraki-ken, 314-0255 Japan Tel.: +81 479 40 1097 Fax.: +81 479 46 1788 e-mail: info@akzoemc.co.jp URL: www.akzoemc.co.jp

Equipment type	Rack Mount Repeater
Trademark	Vertex Standard
Model(s)	VXR-9000U-A
Serial No.	5H000001
FCC ID	K6610444140
IC CN and UPN	511B-10444140
Measurement Method	ANSI/TIA/EIA-603B-2002 / RSS-119 Issue 6(2000)
Deviation from standard(s)	No deviation
Test Result	Complied
Report Number	ANKK-105166
Report issue date	July 22, 2005

This equipment has been shown to be capable of compliance with the applicable standard(s) as indicated in the test report.

I attest to the accuracy of data. All measurements reported herein were performed by me or were made under my supervision and are correct to the best of my knowledge and belief. I assume full responsibility for the completeness of these measurements and vouch for the qualifications of all persons taking them.

This test report shall not be reproduced partially, or in full, without the prior written approval of Akzo Nobel K. K. The results and statements contained in this report pertain only to the equipment evaluated.

Approved by _____

Takeshi Yamanaka / [Site Manager]

Tested by _____

Katsuya Uchida

TABLE OF CONTENTS

	Page
SECTION 1. GENERAL INFORMATION	3
SECTION 2. TEST AND MEASUREMENT DATA	4
SECTION 3. MEASUREMENT RESULT	5
SECTION 4. TEST DATA	
4.1 Carrier Output Power (Conducted)	6
4.2 Unwanted Emissions (Transmitter Conducted)	7
4.3 Field Strength of Spurious Radiation	9
4.4 Emission Masks (Occupied Bandwidth)	12
4.5 Transient Frequency Behavior	15
4.6 Audio Frequency Response / Audio Low Pass Filter (Voice Input)	18
4.7 Modulation Limiting	20
4.8 Frequency Stability (Temperature Variation)	23
4.9 Frequency Stability (Voltage Variation)	25
4.10 Receiver Spurious Emissions(Radiated)	26
SECTION 5. VALIDITY OF TEST REPORT	29
SECTION 6. DESCRIPTION OF TEST SITE	29
APPENDIX PHOTOGRAPHS	

SECTION 1. GENERAL INFORMATION

APPLICANT INFORMATION	
Company	: VERTEX STANDARD CO.,LTD.
Address	: 4-8-8 Nakameguro, Meguro-ku, Tokyo 153-8644, Japan
Attenuation	: Moto Kurihara Group Leader of Engineering Division
Telephone number	: +81 3 5725 6122
Fax number	: +81 3 5725 6225

DESCRIPTION OF TEST ITEM	
Kind of EUT	: Rack Mount Repeater
Condition of EUT	: Prototype
Type	: Table-top type
Trademark	: Vertex Standard
Model number	: VXR-9000U-A
Serial number	: 5H000001
Emission Designation	: 16K0F3E(Wide) / 11K0F3E(Narrow)
Frequency Range	: 400 to 430 MHz
Output Power	: 10 to 50 W (Continuously Variable)
Number of Channel	: 32
Channel Spacing	: 25 kHz (Wide) / 12.5 kHz (Narrow)
Antenna Impedance	: 50 Ω Norminal

TEST PERFORMED	
EUT Received	: June 27, 2005
Test started	: June 27, 2005
Test completed	: July 19, 2005
Temperature	: 21 to 26 degrees C
Humidity	: 42 to 61 %
Atmospheric	: 100.7 to 102.3 kpa
Voltage	: DC 13.6 V
Current	: 12A Maximum
Frequency	: None

TEST TRACABILITY	
Tracability to national standards of test result is achieved by means of calibration tractability to national or international standards.	

ABBREVIATIONS	
EUT = Equipment Under Test	Cal Exp. = Calibration Expire
D.R.G. Antenna = Double Rigid Guide Antenna	

SECTION 2. TEST AND MEASUREMENT DATA

All test and measurements indicated in this document were performed in accordance with the Code of Federal Regulations Title 47 Part 2, Sub-part J and Industry Canada as the following individual parts:

FCC RULE	TEST ITEM	Tested
Part 21	Domestic Public Fixed radio Services	N.A.
Part 22	Non Cellular	YES
Part 22	Public Mobile Services	N.A.
Part 22	Subpart H - Cellular Radiotelephone Service	N.A.
Part 22	Alternative technologies and auxiliary service	N.A.
Part 23	International Fixed Public Radiocommunication service	N.A.
Part 24	Personal Communications Services	N.A.
Part 74	Subpart H - Low Power Auxiliary Stations	YES
Part 80	Stations in the Maritime Services	N.A.
Part 80	Subpart E - general Technical Standards	N.A.
Part 80	Subpart F - Equipment Authorization for Compulsory Ships	N.A.
Part 80	Subpart K - Private Coast Stations and Marine Utility Stations	N.A.
Part 80	Subpart S - Compulsory radiotelephone Installations for Small Passenger Boats	N.A.
Part 80	Subpart T - Radiotelephone Installation Required for Vessels on the Great Lakes	N.A.
Part 80	Subpart U - Radiotelephone Installations Required by the Bridge-to-Bridge Act	N.A.
Part 80	Subpart V - Emergency Position Indicating Radiobeacons (EPIRB'S)	N.A.
Part 80	Subpart W - Global Maritime Distress and Safety System (GMDSS)	N.A.
Part 80	Subpart X - Voluntary Radio Installations	N.A.
Part 87	Aviation Services	N.A.
Part 90	Private Land Mobile radio Services	YES
Part 94	Private Operational - Fixed Microwave Service	N.A.
Part 95	Subpart A - General Mobile radio Service	N.A.
Part 95	Subpart C - Radio Control (R/C) radio Service	N.A.
Part 95	Subpart D - Citizens Band (CB) Radio Service	N.A.
Part 95	Subpart E -Family radio Service	N.A.
Part 95	Subpart F -Interactive Video and Data Service (IVDS)	N.A.
Part 97	Amateur Radio Service	N.A.
Part 101	Fixed Microwave Service	N.A.

IC RULE	TEST ITEM	Tested
RSS-119	Land Mobile and Fixed Radio Transmitters and Receivers	YES

SECTION 3. MEASUREMENT RESULT

FCC Part2	Part22	Part74	Part90	IC	TEST ITEM	RESULTS
2.1046 (a)	-	-		6.2	Carrier Output Power (Conducted)	PASS
2.1051	-	-	90.210	6.3	Unwanted Emissions (Transmitter Conducted)	PASS
2.1053 (a)	-	-	90.210	6.3	Field Strength of Spurious Radiation	PASS
2.1049 (c) (1)	22.359, 357 (a) (1)	74.1236	90.210	6.4	Emission Masks (Occupied Bandwidth)	PASS
-	-	-	90.214	6.5	Transient Frequency Behavior	PASS
2.1047 (a)	-	-	90.242 (b) (8)	6.6	Audio Low Pass Filter (Voice Input)	PASS
2.1047 (a)	-	-	-	6.6	Audio Frequency Response	PASS
2.1047 (b)	-	-	-	6.6	Modulation Limiting	PASS
2.1055 (a) (1)	22.355	74.1261 (b)	90.213 (a)	7	Frequency Stability (Temperature Variation)	PASS
2.1055 (d) (1)	22.355	74.1261 (b)	90.213 (a)	7	Frequency Stability (Voltage Variation)	PASS
-	-	-	-	8	Receiver Spurious Emissions	PASS

Limitation on Results

The test result of this report is effective equipment under test itself and under the test configuration described on the report.

This test report does not assure that whether the test result taken in other testing laboratory is compatible or reproducible to the test result on this report or not.

SECTION 4. TEST DATA

4.1 Carrier Output Power (Conducted)

REGULATIONS	: 47 CFR 2.1046 (a) / RSS-119 Section 6.2
TEST METHOD/GUIDE	: ANSI/TIA/EIA-603-1992, section 2.2.1.2 / RSS-119 Section 6.2

TEST PROCEDURE

- 1 The EUT and test equipment were set up as shown on the following page.
- 2 The EUT was conducted to a resistive coaxial attenuator of normal load impedance.

RF Power (dBm) = Power Meter reading (dBm) + Attenuator (dB) + Cable loss (dB)

RF Power (W) = 10^{(RF Power (dBm)/10)}/1000

TEST EQUIPMENTS

No.	Equipment	Manufacture	Model No.	Serial No.	Cal Exp.
1	Power Meter	Hewlett Packard	E4418B	GB38410265	Sep-05
2	Power Sensor	Hewlett Packard	8482A	2607A11551	Jan-06
3	Attenuator (30dB)	Weinschel	53-30-33	KX496	May-06
4	Attenuator (20dB)	Weinschel	40-20-34	AA5701	Jul-05
5	50Ω Termination	TME	CT-01	None	Jul-05
6	DC Power Supply	Kikusui	PAK20-36A	Z0605078	None
7	Digital Multi Meter	Sanwa	CD721	3215593	Apr-06

MEASUREMENT EQUIPMENT CONFIGURATION

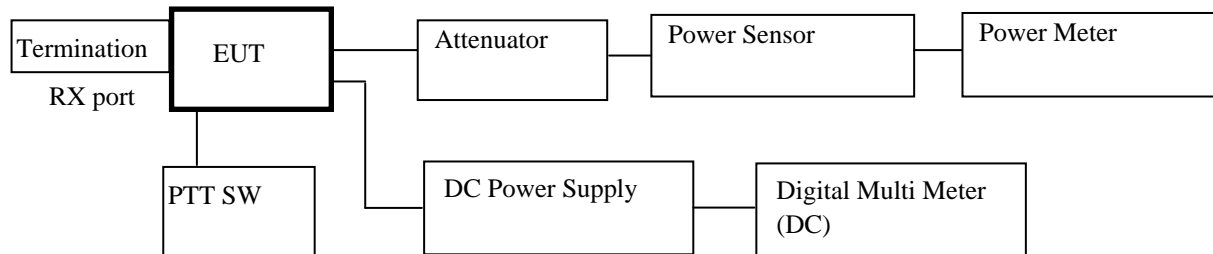

UNCERTAINTY

Measurement uncertainty is +/- 0.5dB (k = 2)

TEST RESULTS

Measured for the worst case

No.	Frequency (MHz)	Setting	RF Power (W)
1	400.00	Low High Power	50
2	415.00	Mid High Power	50
3	430.00	High High Power	50
4	400.00	Low Low Power	10
5	415.00	Mid Low Power	10
6	430.00	High Low Power	10

4.2 Unwanted Emissions (Transmitter Conducted)

REGULATIONS	: 47 CFR 2.1051, 90.210 / RSS-119 Section 6.3
TEST METHOD/GUIDE	: ANSI/TIA/EIA-603-1992, section 2.2.13.2 / RSS-119 Section 6.3

TEST PROCEDURE

- The EUT and test equipment were set up as shown on the following page.
- Modulate the transmitter with a 2.5 kHz sine wave at an input Level of 16 dB greater than that necessary to produce 50 % of rated system deviation.
- Adjust the spectrum analyzer for the following setting:
 - Resolution Bandwidth : 10 kHz (< 1 GHz), 1 MHz (> 1 GHz).
 - Video Bandwidth : 30 kHz (< 1 GHz), 3 MHz (> 1 GHz).
 - Sweep Speed : 50 msec.
 - Detector mode : Average
- The emissions were measured for the worst case as follows:
 - : within a band of frequencies defined by the carrier frequency plus and minus one channel.
 - : from the lowest frequency generated in the EUT and to at least the 10th harmonic of the carrier frequency, or 40 GHz, whichever is lower.

TEST EQUIPMENTS

No.	Equipment	Manufacture	Model No.	Serial No.	Cal Exp.
1	Audio Generator	ANRITSU	MG443B	1004468	Jul-05
2	Attenuator (30dB)	Weinschel	53-30-33	KX496	May-06
3	Attenuator (20dB)	Weinschel	40-20-34	AA5701	Jul-05
4	High Pass Filter	ANRITSU	MP526D	6200220657	Jun-05
5	Modulation Analyzer	Hewlett Packard	8901B	2806A01669	Sep-05
6	Signal Generator (100kHz-3000MHz)	Rohde & Schwarz	SMT03	841733/010	Jun-06
7	Synthesizer Signal Generator (2GHz-18GHz)	Hewlett Packard	8672A	2449A04106	Jan-06
8	Spectrum Analyzer	Agilent	E7403A	MY42000062	Jul-05
9	50Ω Termination	TME	CT-01	None	Jul-05
10	DC Power Supply	Kikusui	PAK20-36A	Z0605078	None
11	Digital Multi Meter	Sanwa	CD721	3040938	Apr-06

MEASUREMENT EQUIPMENT CONFIGURATION

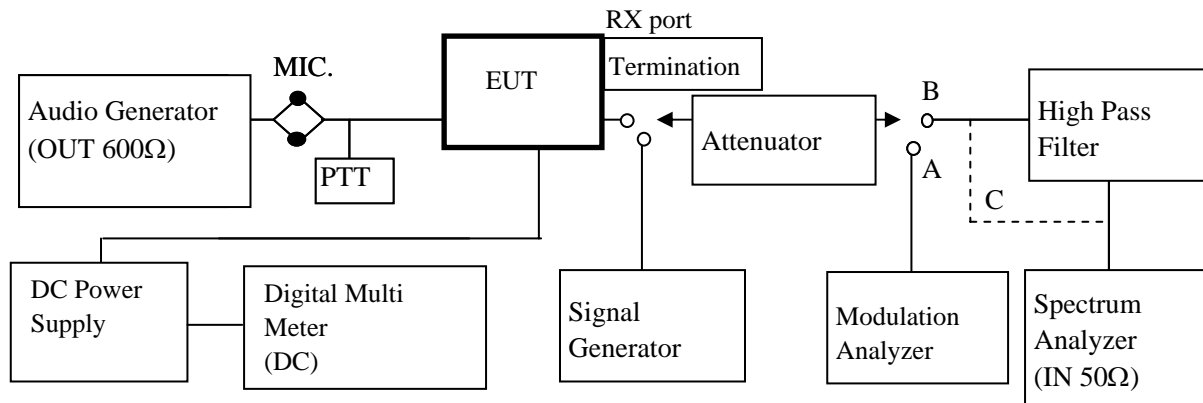

UNCERTAINTY

Measurement uncertainty is +/- 1.2 dB (k = 2)

TEST RESULTS

Measured for the worst case

State : High Power / Narrow Band Modulation

No.	Frequency (MHz)		Correct Level (dBm)	Emission Level (dBc)	Limit (dBc)	Margin (dB)
1	800.00	Low	-49.10	-96.09	-67.0	29.1
2	1200.00	Low	-35.60	-82.59	-67.0	15.6
3	1600.00	Low	-34.90	-81.89	-67.0	14.9
4	830.00	Mid	-48.90	-95.89	-67.0	28.9
5	1245.00	Mid	-35.10	-82.09	-67.0	15.1
6	1660.00	Mid	-34.10	-81.09	-67.0	14.1
7	860.00	High	-47.80	-94.79	-67.0	27.8
8	1290.00	High	-35.80	-82.79	-67.0	15.8
9	1720.00	High	-33.90	-80.89	-67.0	13.9

There is the margin of 20dB over except for the above points.

State : Low Power / Narrow Band Modulation

No.	Frequency (MHz)		Correct Level (dBm)	Emission Level (dBc)	Limit (dBc)	Margin (dB)
1	800.00	Low	-53.50	-93.50	-60.0	33.5
2	1200.00	Low	-36.10	-76.10	-60.0	16.1
3	1600.00	Low	-36.50	-76.50	-60.0	16.5
4	830.00	Mid	-56.20	-96.20	-60.0	36.2
5	1245.00	Mid	-35.70	-75.70	-60.0	15.7
6	1660.00	Mid	-34.30	-74.30	-60.0	14.3
7	860.00	High	-56.10	-96.10	-60.0	36.1
8	1290.00	High	-37.30	-77.30	-60.0	17.3
9	1720.00	High	-34.00	-74.00	-60.0	14.0

There is the margin of 20dB over except for the above points.

Mask D Limit (dBc) = $-(50+10\log(P))$

Correct Level (dBm) = Substitute SG Level (dBm)

Emission Level (dBc) = Correct Level (dBm) - $10\log(P*1000)$

P = Carrier Level (W)

4.3 Field Strength of Spurious Radiation

REGULATIONS	: 47 CFR 2.1053 (a), 90.210 / RSS-119 Section 6.2
TEST METHOD/GUIDE	: ANSI/TIA/EIA-603-1992, section 2.2.12.2 / RSS-119 Section 6.2

TEST PROCEDURE

- 1 The EUT and test equipment were set up as shown on the following page.
- 2 Adjust the spectrum analyzer for the following setting:
 - a) Resolution Bandwidth : 10 kHz (< 1 GHz), 1 MHz (> 1 GHz).
 - b) Video Bandwidth : 300 kHz (< 1 GHz), 3 MHz (> 1 GHz).
 - c) Sweep Speed : 50ms.
 - d) Detector mode : Positive Peak
- 3 The transmitter was placed on a wooden turntable, and it was transmitting into non-radiating load which was also placed on the turntable.
- 4 The measurement antenna was placed at a distance of 3 meters from the EUT. During the tests, the antenna height and polarization as well as EUT azimuth were varied in order to identify the maximum level of emissions from the EUT. The test was performed by placing the EUT on 3-orthogonal axis.
- 5 The frequency range up to tenth harmonic of the fundamental frequency was investigated.
- 6 Remove the EUT and replace it with substitution antenna. A signal generator was connected to the substitution antenna by a non-radiating cable. The absolute levels of the spurious emissions were measured by the substitution.
- 7 Spurious emissions in dB = 10 Log (TX power in Watts/0.001) – the absolute level
- 8 Spurious attenuation Wide Band Modulaion limit in dB = 43 + 10 Log10 (power out in Watts)
- 9 Spurious attenuation Narrow Band Modulaion limit in dB = 50 + 10 Log10 (power out in Watts)

TEST EQUIPMENTS

No.	Equipment	Manufacture	Model No.	Serial No.	Cal Exp.
1	Dipole Antenna(TX)	Schwarzbeck	UHA9105	None	Mar-06
2	D.R.G Antenna(TX)	Schwarzbeck	BBHA 9120 D	457	Apr-06
3	Tri-log Antenna(RX)	Schwarzbeck	VULB9167WP	106	Mar-06
4	D.R.G Antenna(RX)	Schwarzbeck	3115	9612-5044	Jul-05
5	Pre-Amplifier	Toyo Technica	TPA0118-30	0402	Sep-05
6	Step Attenuator	Hewlett Packard	8494B	2726A14513	Oct-05
7	Attenuator(6dB)	ANRITSU	MP720B	M57593	Oct-05
8	Attenuator(3dB)	Narda	3157845	4538	Sep-05
9	Spectrum Analyzer	Agilent	E7403A	MY42000062	Jul-05
10	Signal Generator (100kHz - 1500MHz)	Rohde & Schwars	SMT02	842477/016	May-06
11	Signal Generator (1GHz - 40GHz)	Rohde & Schwars	SMR40	834128/028	Sep-05
12	50Ω Termination	TME	CT-01	None	Jul-05
13	Dummy Load	BIRD	8401	6164	Feb-06
14	DC Power Supply	Daiwa	PS-3020	None	None
15	Digital Mlti Meter	Sanwa	CD721	3215593	Apr-06

MEASUREMENT EQUIPMENT CONFIGURATION

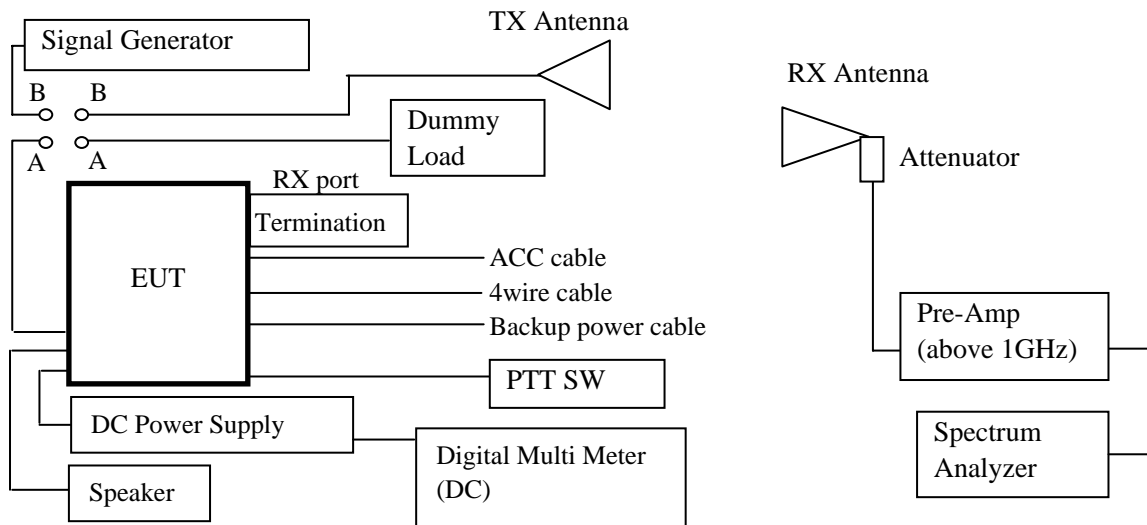

UNCERTAINTY

Measurement uncertainty is +/- 4.2dB (k = 2)

TEST RESULTS

Measured for the worst case

State : High Power / Narrow Band Modulation / 400.00 MHz

No	Frequency (MHz)	Pol	Reading Level (dBm)	SG Out Level (dBm)	Cable Loss (dB)	Antenna Gain (dBi)	Correct Level (dBm)	Emission Level (dBc)	Limit Level (dBc)	Margin (dB)
1	800.00	Hor.	-76.90	-34.70	2.16	2.15	-34.7	-81.7	-67.0	14.7
		Ver.	-70.05	-30.00	2.16	2.15	-30.0	-77.0	-67.0	10.0
2	1200.00	Hor.	-36.28	-39.95	1.62	7.39	-34.2	-81.2	-67.0	14.2
		Ver.	-32.48	-33.15	1.62	7.39	-27.4	-74.4	-67.0	7.4
3	1600.00	Hor.	-51.26	-52.30	1.87	9.39	-44.8	-91.8	-67.0	24.8
		Ver.	-50.60	-52.70	1.87	9.39	-45.2	-92.2	-67.0	25.2
4	2000.00	Hor.	-66.68	-62.90	2.10	10.33	-54.7	-101.7	-67.0	34.7
		Ver.	-60.11	-57.40	2.10	10.33	-49.2	-96.2	-67.0	29.2
5	2400.00	Hor.	-58.20	-57.80	2.32	10.55	-49.6	-96.6	-67.0	29.6
		Ver.	-59.20	-56.00	2.32	10.55	-47.8	-94.8	-67.0	27.8
6	2800.00	Hor.	-56.50	-55.00	2.52	11.19	-46.3	-93.3	-67.0	26.3
		Ver.	-54.36	-51.10	2.52	11.19	-42.4	-89.4	-67.0	22.4
7	3200.00	Hor.	-61.92	-58.50	2.70	11.99	-49.2	-96.2	-67.0	29.2
		Ver.	-60.44	-57.10	2.70	11.99	-47.8	-94.8	-67.0	27.8
8	3600.00	Hor.	-60.12	-56.80	2.92	12.60	-47.1	-94.1	-67.0	27.1
		Ver.	-60.23	-51.50	2.92	12.60	-41.8	-88.8	-67.0	21.8
9	4000.00	Hor.	-64.71	-60.60	3.17	12.55	-51.2	-98.2	-67.0	31.2
		Ver.	-61.60	-47.60	3.17	12.55	-38.2	-85.2	-67.0	18.2

There is the margin of 20dB over except for the above points.

Mask D Limit (dBc) = $-(50+10\text{Log}(P))$

Correct Level (dBm) = Substitute SG Level (dBm) + ANT Gain (dBi) - Cable loss (dB)

Emission Level (dBc) = Correct Level (dBm) - $10\text{Log}(P*1000)$

P = Carrier Level (W)

State : Low Power / Narrow Band Modulation / 400.00 MHz

No	Frequency (MHz)	Pol	Reading Level (dBm)	SG Out Level (dBm)	Cable Loss (dB)	Antenna Gain (dBi)	Correct Level (dBm)	Emission Level (dBc)	Limit Level (dBc)	Margin (dB)
1	800.00	Hor.	-79.32	-37.20	2.16	2.15	-37.2	-77.2	-60.0	17.2
		Ver.	-72.10	-32.20	2.16	2.15	-32.2	-72.2	-60.0	12.2
2	1200.00	Hor.	-43.43	-42.90	1.62	7.39	-37.1	-77.1	-60.0	17.1
		Ver.	-35.40	-36.10	1.62	7.39	-30.3	-70.3	-60.0	10.3
3	1600.00	Hor.	-48.79	-49.70	1.87	9.39	-42.2	-82.2	-60.0	22.2
		Ver.	-44.44	-47.10	1.87	9.39	-39.6	-79.6	-60.0	19.6
4	2000.00	Hor.	-65.62	-61.83	2.10	10.33	-53.6	-93.6	-60.0	33.6
		Ver.	-64.26	-61.55	2.10	10.33	-53.3	-93.3	-60.0	33.3
5	2400.00	Hor.	-62.15	-61.75	2.32	10.55	-53.5	-93.5	-60.0	33.5
		Ver.	-61.72	-58.52	2.32	10.55	-50.3	-90.3	-60.0	30.3
6	2800.00	Hor.	-57.74	-56.24	2.52	11.19	-47.6	-87.6	-60.0	27.6
		Ver.	-55.79	-52.53	2.52	11.19	-43.9	-83.9	-60.0	23.9
7	3200.00	Hor.	-65.35	-61.93	2.70	11.99	-52.6	-92.6	-60.0	32.6
		Ver.	-61.22	-57.88	2.70	11.99	-48.6	-88.6	-60.0	28.6
8	3600.00	Hor.	-65.02	-61.70	2.92	12.60	-52.0	-92.0	-60.0	32.0
		Ver.	-65.47	-56.74	2.92	12.60	-47.1	-87.1	-60.0	27.1
9	4000.00	Hor.	-63.61	-59.50	3.17	12.55	-50.1	-90.1	-60.0	30.1
		Ver.	-63.77	-49.77	3.17	12.55	-40.4	-80.4	-60.0	20.4

There is the margin of 20dB over except for the above points.

Mask D Limit (dBc) = $-(50+10\log(P))$

Correct Level (dBm) = Substitute SG Level (dBm) + ANT Gain (dBi) - Cable loss (dB)

Emission Level (dBc) = Correct Level (dBm) - $10\log(P*1000)$

P = Carrier Level (W)

4.4 Emission Masks (Occupied Bandwidth)

REGULATIONS	: 47 CFR 2.1049 (c) (1), 22.359, 357 (a) (1) , 74.1236 , 90.210 RSS-119 Section 6.4
TEST METHOD/GUIDE	: ANSI/TIA/EIA-603-1992, section 2.2.11.2 / RSS-119 Section 6.4

TEST PROCEDURE

- 1 The EUT and test equipment were set up as shown on the following page.
- 2 For EUT supporting audio modulation, the audio signal generator was adjusted to the frequency of maximum response and with output level set for +/- 2.5 kHz or +/- 1.25 kHz deviation (or 50 % modulation).
- 3 With level constant, the signal level was increased 16 dB.
For EUT supporting digital modulation, the digital modulation mode was operated to its maximum extent.
- 4 Adjust the spectrum analyzer for the following setting:
 - a) Resolution Bandwidth : 100 Hz (Nonmodulation and Narrow modulation), 300 Hz (Wide modulation).
 - b) Video Bandwidth : 100 Hz (Nonmodulation and Narrow band modulation), 3kHz(Wide band modulation).
 - c) Sweep Speed : 8 sec.
 - d) Sampling Time : 10 times
- 5 The occupied Bandwidth was measured with the Spectrum Analyzer controls set as shown on the test results.

TEST EQUIPMENTS

No.	Equipment	Manufacture	Model No.	Serial No.	Cal Exp.
1	Audio Generator	ANRITSU	MG443B	1004468	Jul-05
2	Attenuator (30dB)	Weinschel	53-30-33	KX496	May-06
3	Attenuator (20dB)	Weinschel	40-20-34	AA5701	Jul-05
4	Modulation Analyzer	Hewlett Packard	8901B	2806A01669	Sep-05
5	Spectrum Analyzer	Agilent	E7403A	MY42000062	Jul-05
6	DC Power Supply	Kikusui	PAK20-36A	Z0605078	None
7	50Ω Termination	TME	CT-01	None	Jul-05
8	Digital Multi Meter	Sanwa	CD721	3215593	Apr-06

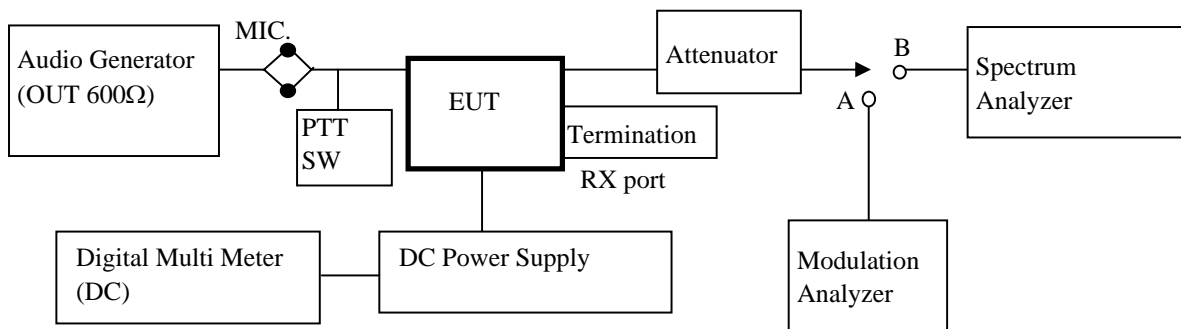

UNCERTAINTY

Measurement uncertainty is +/- 1.2dB (k = 2)

TEST RESULTS

Measured for the worst case

State : High Power / None Modulation:FM / 400.00 MHz

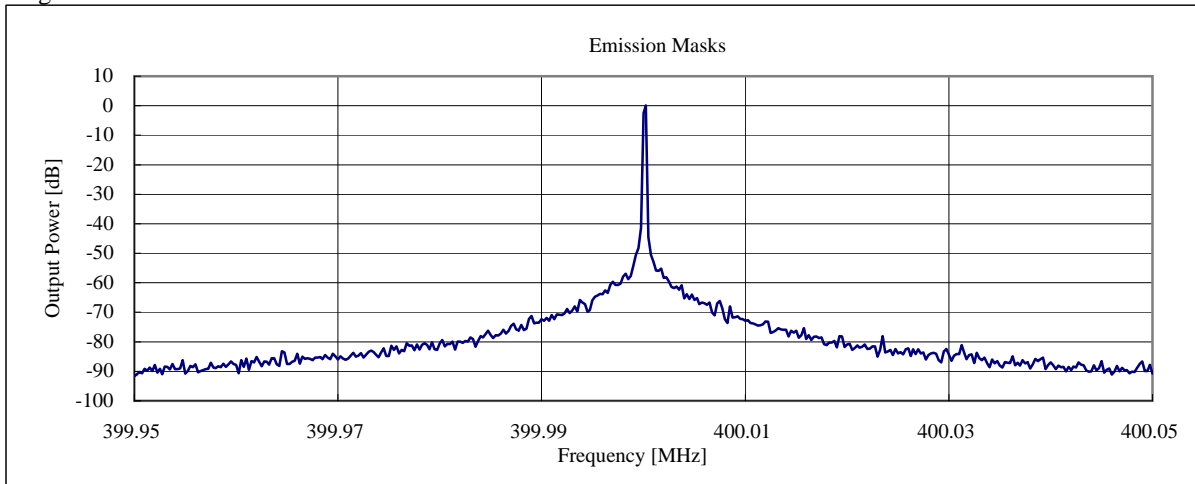

State : High Power / Narrow Band Modulation:FM / 400.00 MHz

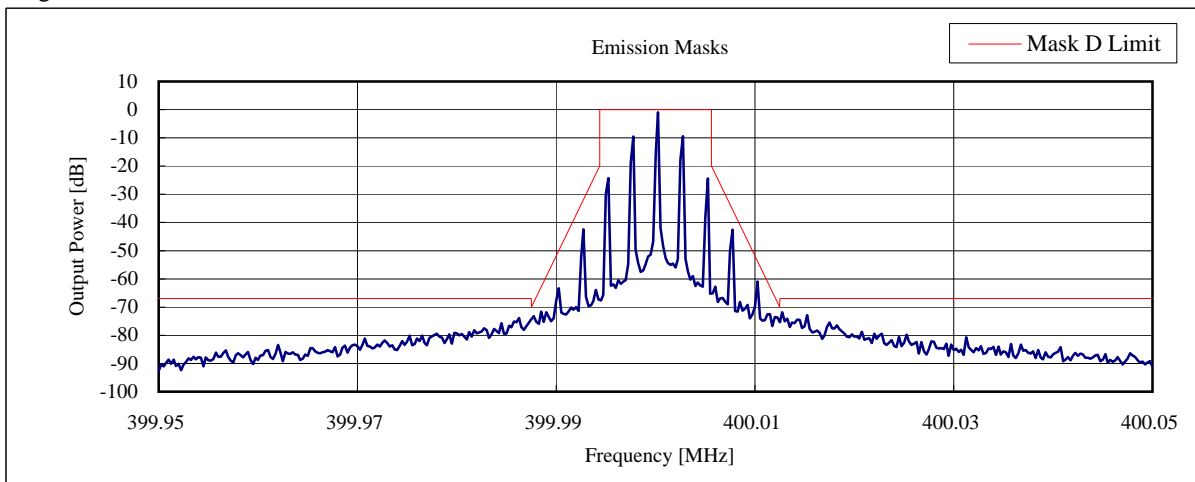

State : High Power / Wide Band Modulation:FM / 400.00 MHz

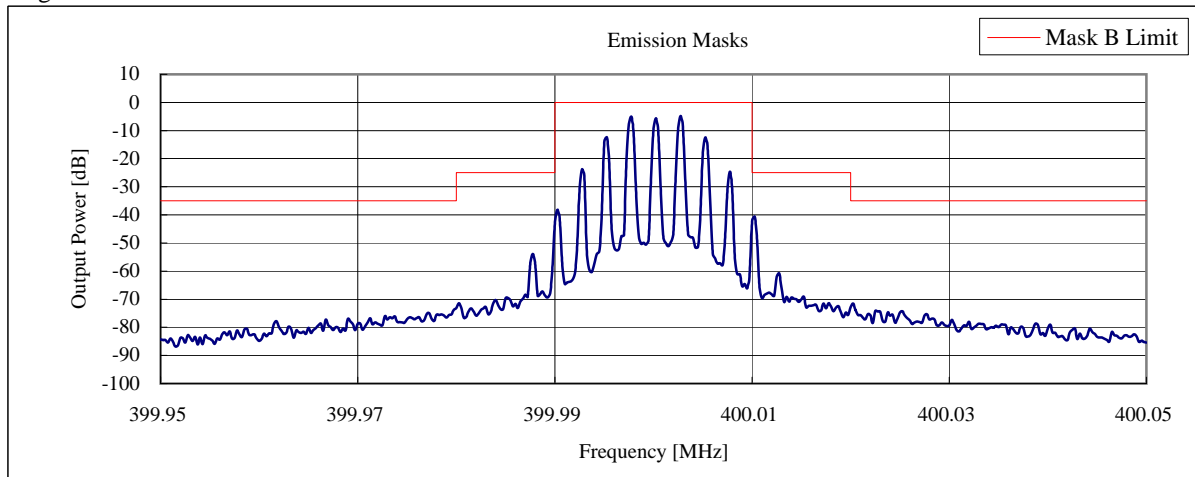

State : Low Power / None Modulation:FM / 400.00 MHz

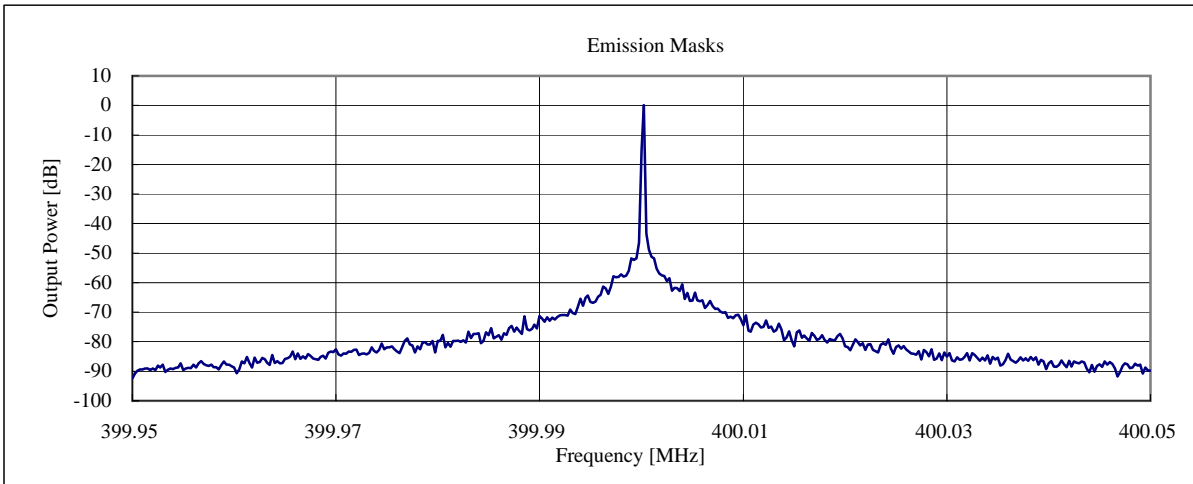

State : Low Power / Narrow Band Modulation:FM / 400.00 MHz

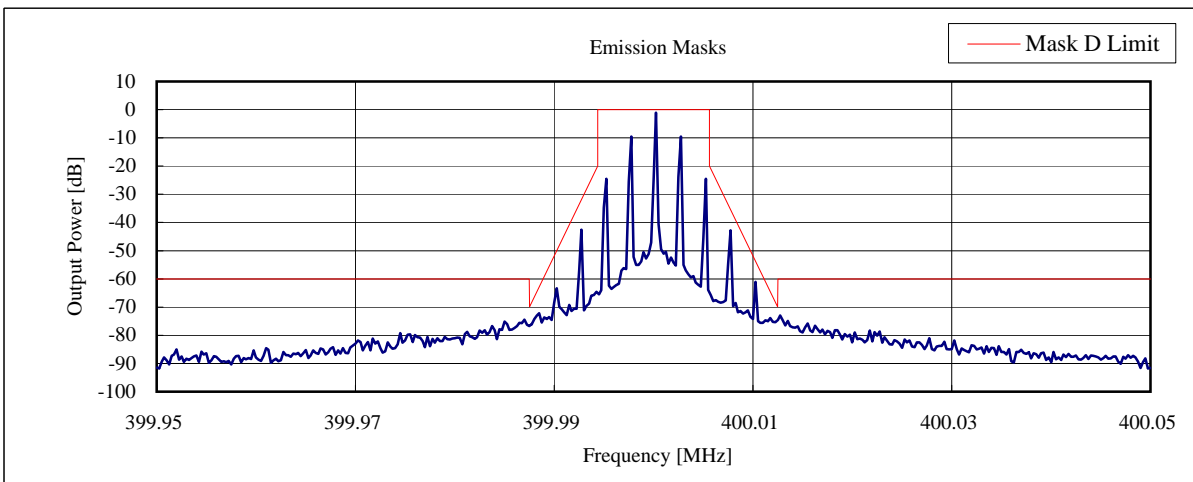

State : Low Power / Wide Band Modulation:FM / 400.00 MHz

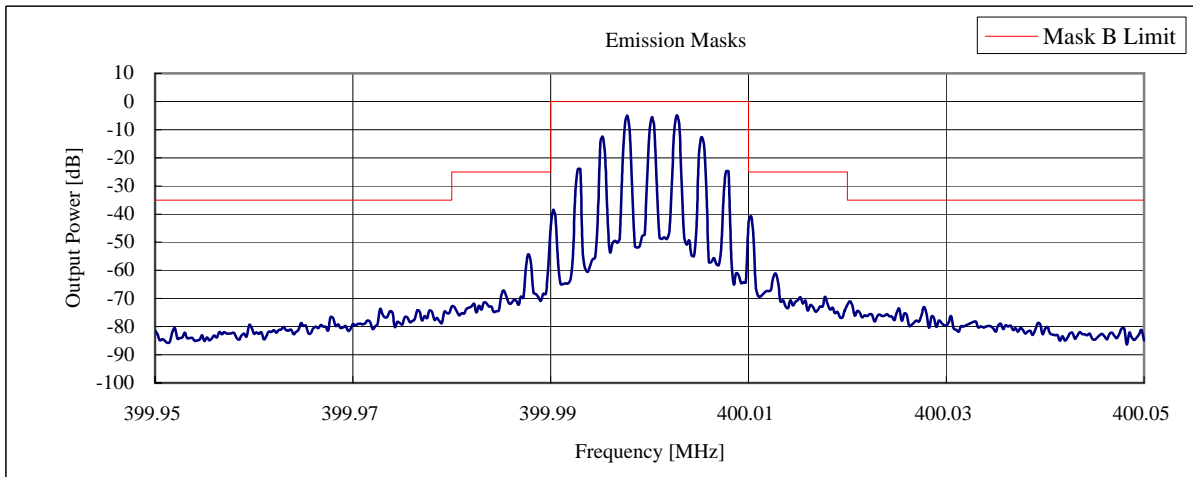

4.5 Transient Frequency Behavior

REGULATIONS	: 47 CFR 90.214 / RSS-119 Section 6.5
TEST METHOD/GUIDE	: ANSI/TIA/EIA-603-1992, section 2.2.19.3 / RSS-119 Section 6.5

TEST PROCEDURE

- 1 The EUT and test equipment were set up as shown on the following page.
- 2 The transmitter was turned on.
- 3 Sufficient attenuation was provided so that the transmitter carrier level measured at the output of the combiner was 40 dB below the maximum input level of the test receiver.
This level was recorded as step f.
- 4 The transmitter was turned off.
- 5 An RF signal generator (1) modulated with a 1 kHz tone at either 25 kHz or 12.5 kHz deviation, and set to the same frequency as the assigned transmitter frequency, (2) was adjusted to a level -20 dB below the level recorded for step f, as measured at the output of the combiner.
This level was then fixed for the remainder of the test and is recorded at step h.
- 6 The oscilloscope was setup using TIA/EIA-603B-2002 steps j and k as a guide, and to 10 msec./div.
- 7 The transmitter was turned on, and the level of the carrier at the output of the combiner was recorded as step l.
- 8 The carrier on-time as referenced in TIA/EIA-603B-2002 steps m, n, and o was captured and plotted.
- 9 The carrier off-time as referenced in TIA/EIA-603B-2002 steps p, q, r, and s was captured and plotted.

TEST EQUIPMENTS

No.	Equipment	Manufacture	Model No.	Serial No.	Cal Exp.
1	Signal Generator	Hewlett Packard	8657B	3247U03266	Feb-06
2	Oscilloscope	IWATSU-LeCroy	LT342	00922	Aug-05
3	Power Meter	Hewlett Packard	E4418B	GB38410265	Sep-05
4	Power Sensor	Hewlett Packard	8482A	2607A11551	Jan-06
5	Attenuator (30dB)	Weinschel	53-30-33	KX496	May-06
6	Modulation Analyzer	Hewlett Packard	8901B	2806A01669	Sep-05
7	Combiner(1)	ANRITSU	M89249	None	Jul-05
8	Combiner(2)	ANRITSU	M89249	None	Jul-05
9	Attenuator (3dB)	TME	CFA-20NPJ-3	679701	Aug-05
10	50Ω Termination	TME	CT-01	None	Jul-05
11	DC Power Supply	Kikusui	PAK20-36A	Z0605078	None
12	Digital Multi Meter	Sanwa	CD721	3040939	Apr-06

MEASUREMENT EQUIPMENT CONFIGURATION

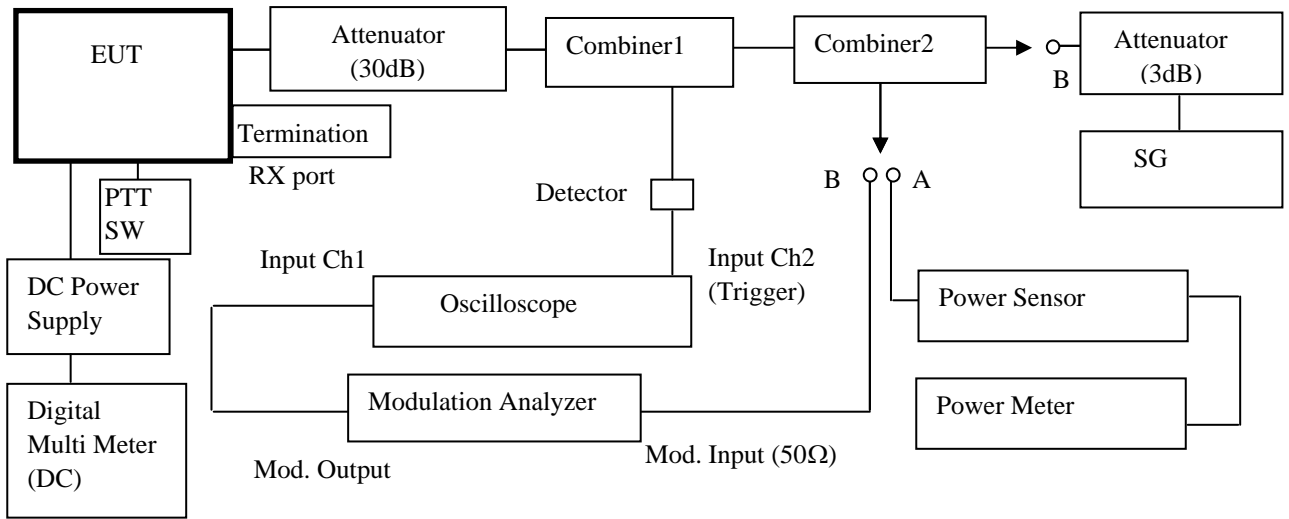

UNCERTAINTY

Measurement uncertainty is +/- 1.3dB (k = 2)

TEST RESULTS

Measured for the worst case

PTT: OFF-ON

State : High Power / Wide Band Modulation / 430.00 MHz

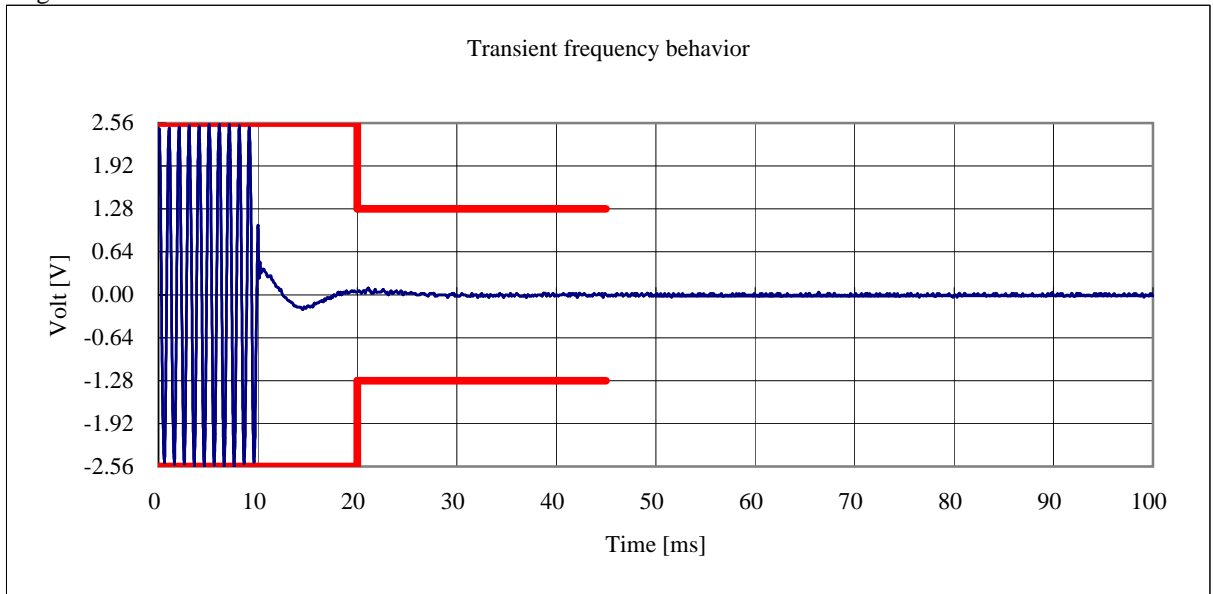

PTT: ON-OFF

State : High Power / Wide Band Modulation / 430.00 MHz

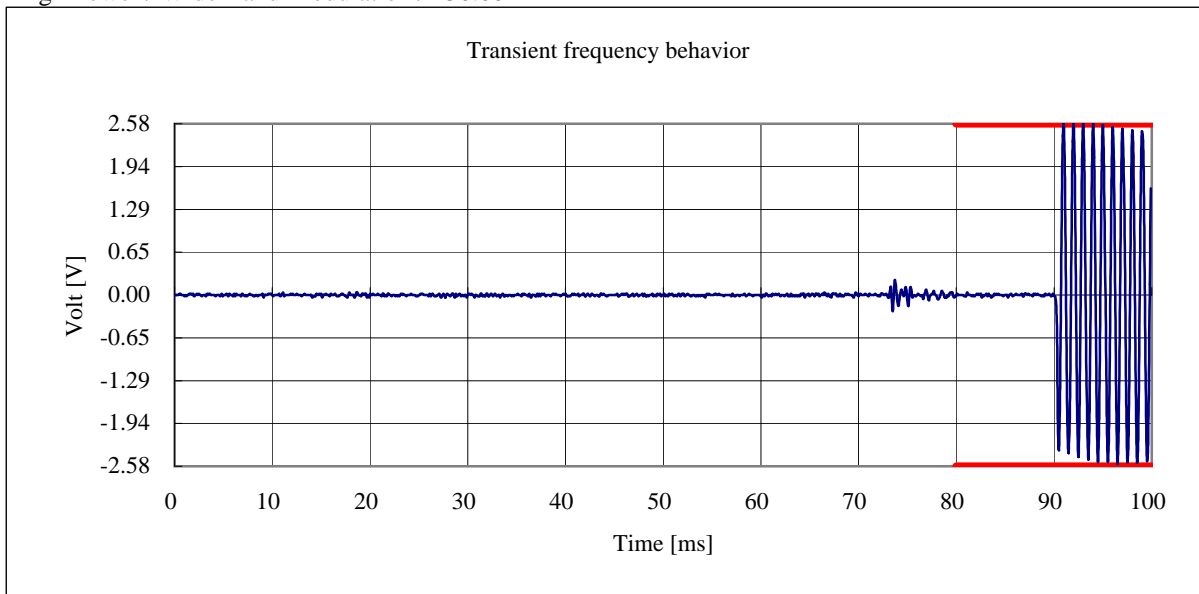

4.6 Audio Frequency Response / Audio Low Pass Filter (Voice Input)

REGULATIONS	: 47 CFR 2.1047 (a) / RSS-119 Section 6.6
TEST METHOD/GUIDE	: ANSI/TIA/EIA-603-1992, section 2.2.6.2.2, 3.2.6.2 / RSS-119 Section 6.6

TEST PROCEDURE

- 1 The EUT and test equipment were set up as shown on the following page.
- 2 Adjust the Modulation Analyzer for the following setting:
 - a) High-pass filter : 50 Hz
 - b) Low-pass filter : 15 kHz
 - c) Detector : positive peak
 - d) Function : FM
- 3 The audio signal input was adjusted to obtain 20 % modulation at 1 kHz, and this point was taken as the 0 dB reference level.
- 4 With input levels held constant and below limiting at all frequencies, the audio signal generator was varied from 300 Hz to 5 kHz.
- 5 The response in dB relative to 1 kHz was then measured, using the Modulation Analyzer.

TEST EQUIPMENTS

No.	Equipment	Manufacture	Model No.	Serial No.	Cal Exp.
1	Audio Generator	ANRITSU	MG443B	1004468	Jul-05
2	Attenuator (30dB)	Weinschel	53-30-33	KX496	May-06
3	Attenuator (20dB)	Weinschel	40-20-34	AA5701	Jul-05
4	50Ω Termination	TME	CT-01	None	Jul-05
5	Modulation Analyzer	Hewlett Packard	8901B	2806A01669	Sep-05
6	Digital Multi Meter (1)	Hewlett Packard	34401A	US36043517	Jul-05
7	DC Power Supply	Kikusui	PAK20-36A	Z0605078	None
8	Digital Multi Meter (2)	Sanwa	CD721	3215593	Apr-06

MEASUREMENT EQUIPMENT CONFIGURATION

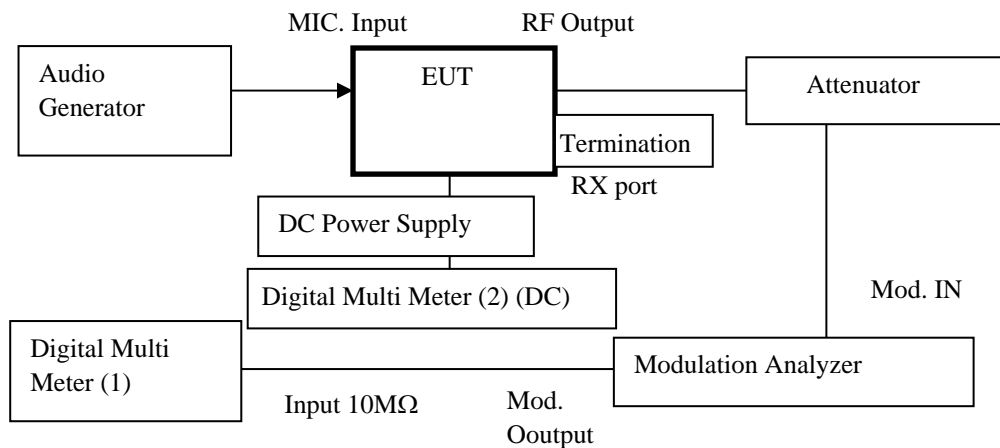

UNCERTAINTY

Measurement uncertainty is +/- 1.2dB (k = 2)

TEST RESULTS

Measured for the worst case

State : High Power / Wide Band Modulation / 430.00 MHz

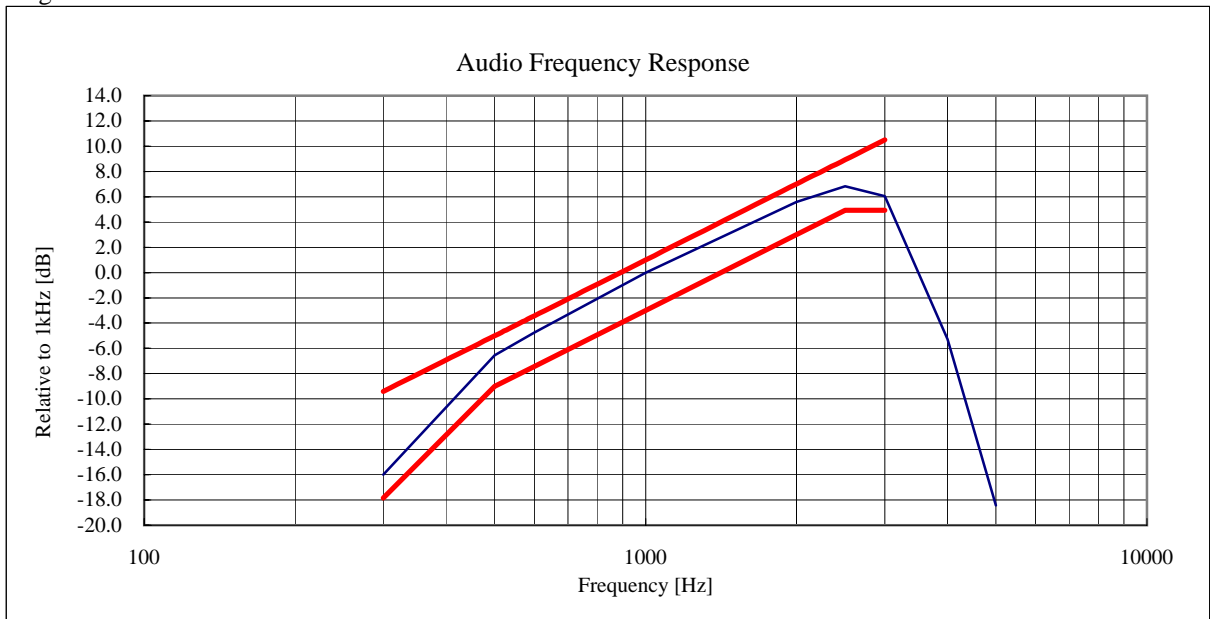

State : High Power / Narrow Band Modulation / 430.00 MHz

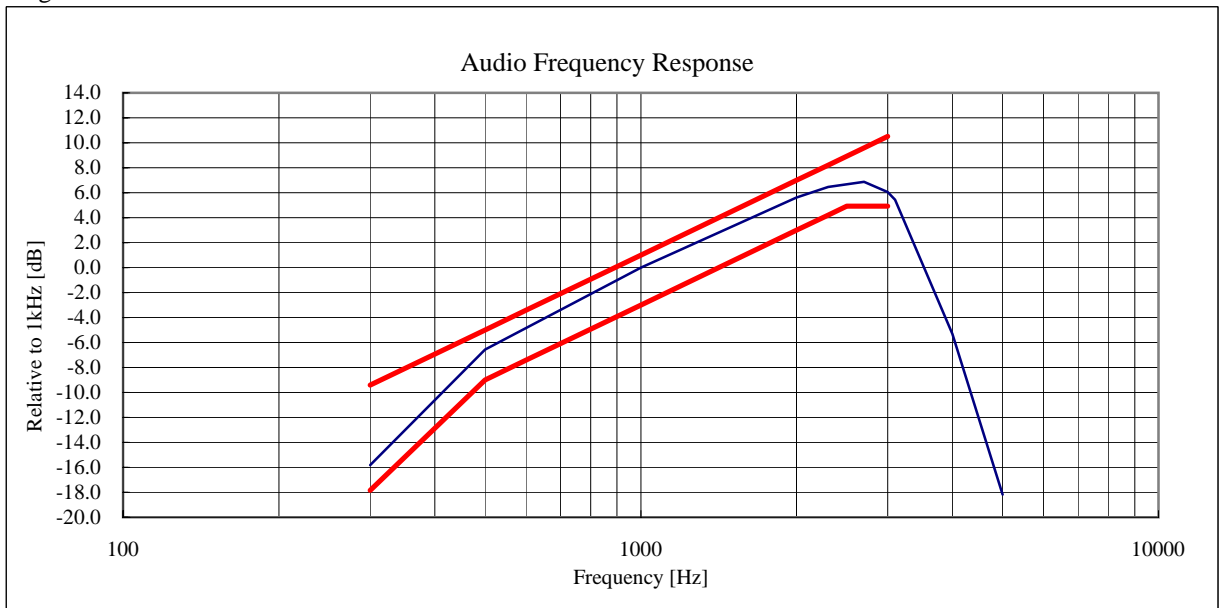

Note:

Audio Filter of the above result is substituted with the same structure as Audio Frequency Resonse.

On the transmission condition below 3kHz, Transceiver shows pre-emphasis condition of transmission function.

On the transmission condition above 3kHz, Transceiver shows Audio Low Pass Filter.

4.7 Modulation Limiting

REGULATIONS	: 47 CFR 2.1047 (b) / RSS-119 Section 6.6
TEST METHOD/GUIDE	: ANSI/TIA/EIA-603-1992, section 2.2.3.2, 1.3.4.4 / RSS-119 Section 6.6

TEST PROCEDURE

- 1 The EUT and test equipment were set up as shown on the following page.
- 2 Adjust the Modulation Analyzer for the following setting:
 - a) High-pass filter : off
 - b) Low-pass filter : 15 kHz
 - c) Detector : positive peak
 - d) Function : FM
- 3 Apply a 1kHz modulating signal to the transmitter from the audio generator, and adjust the level to obtain 60% of full rated system deviation.
- 4 Measure the modulation frequency that was showed on the Modulation Analyzer when the output levels of the Audio Generator were changed from -20 dB to +50 dB by 10 dB.
- 5 Set the output frequencies of the Audio Generator 300 Hz and 3 kHz, and repeat test procedure 4.
- 6 Set the the Detector of the Modulation Analyzer Negative Peak.
- 7 Repeat test procedure 4 and 5.

TEST EQUIPMENTS

No.	Equipment	Manufacture	Model No.	Serial No.	Cal Exp.
1	Audio Generator	ANRITSU	MG443B	1004468	Jul-05
2	Attenuator (30dB)	Weinschel	53-30-33	KX496	May-06
3	Attenuator (20dB)	Weinschel	40-20-34	AA5701	Jul-05
4	50Ω Termination	TME	CT-01	None	Jul-05
5	Modulation Analyzer	Hewlett Packard	8901B	2806A01669	Sep-05
6	DC Power Supply	Kikusui	PAK20-36A	Z0605078	None
7	Digital Multi Meter	Sanwa	CD721	3125593	Apr-06

MEASUREMENT EQUIPMENT CONFIGURATION

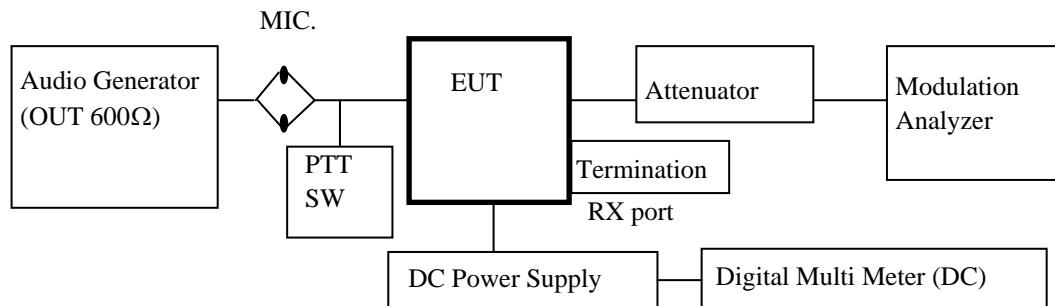

UNCERTAINTY

Measurement uncertainty is +/- 0.8dB (k = 2)

TEST RESULTS

Measured for the worst case

State : High Power / Wide Band Modulation / 415.00 MHz

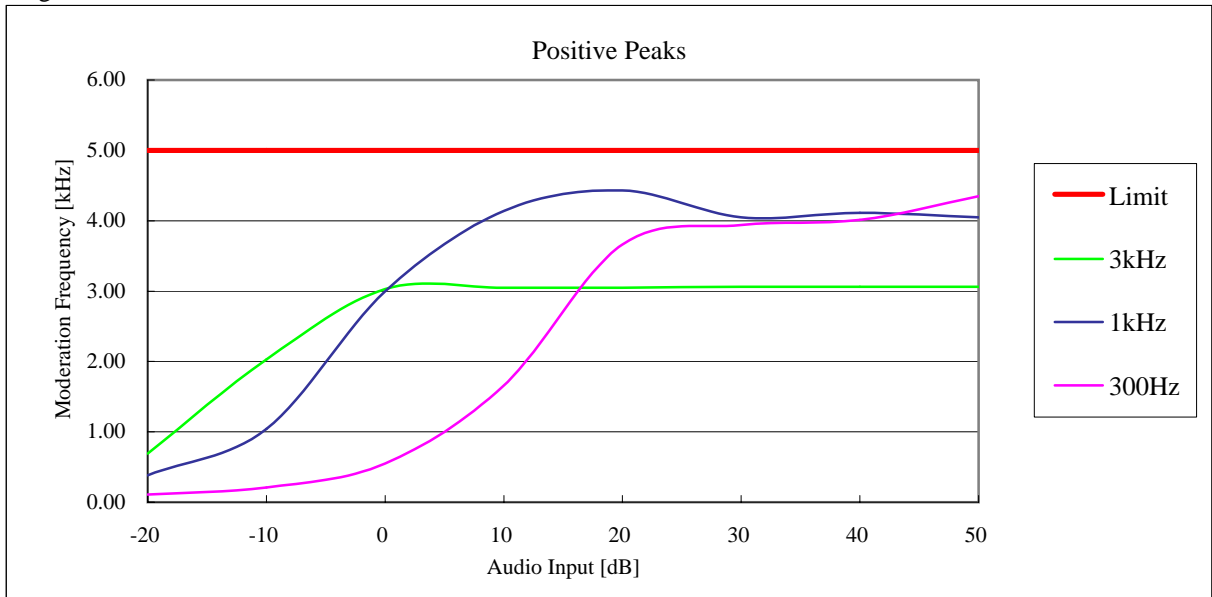

State : High Power / Wide Band Modulation / 415.00 MHz

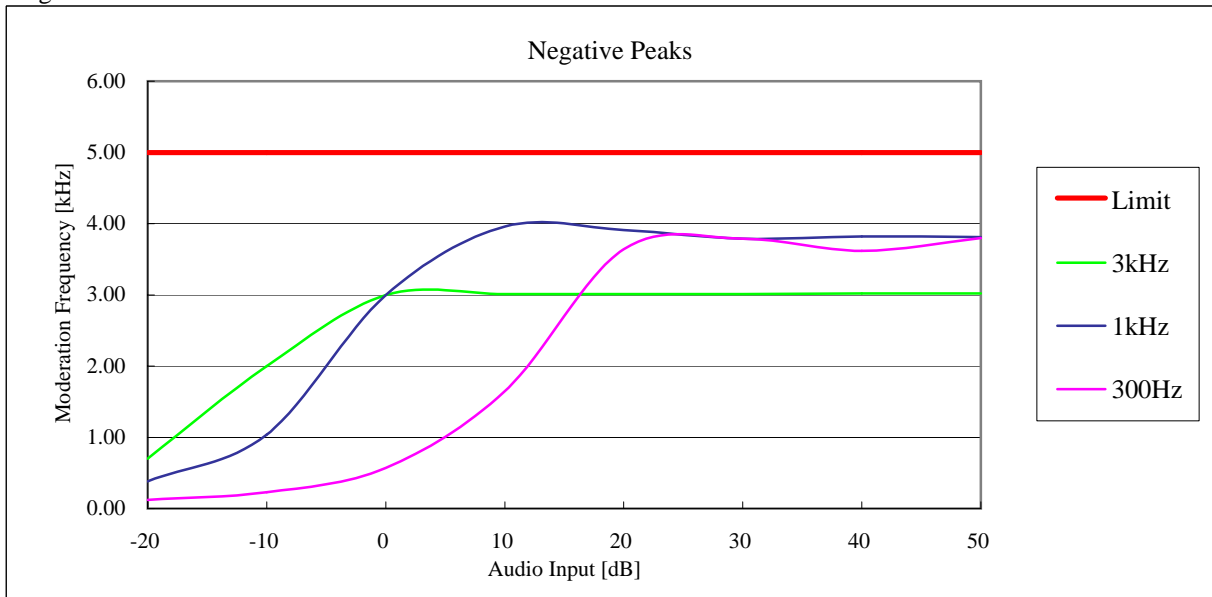

State : High Power / Narrow Band Modulation / 415.00 MHz

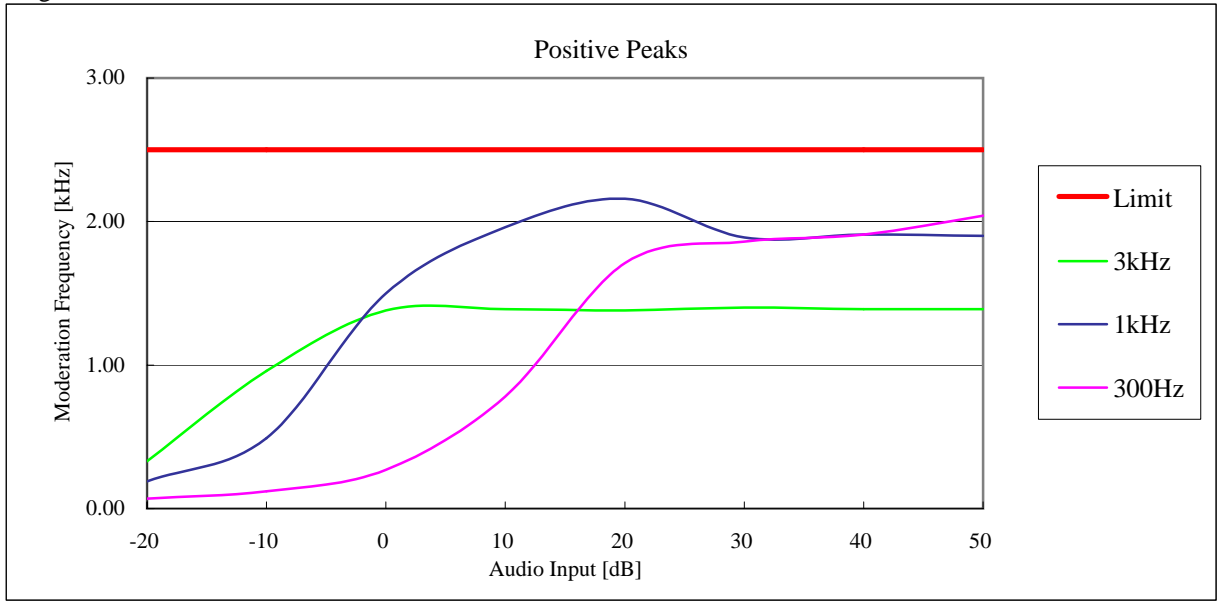

State : High Power / Narrow Band Modulation / 415.00 MHz

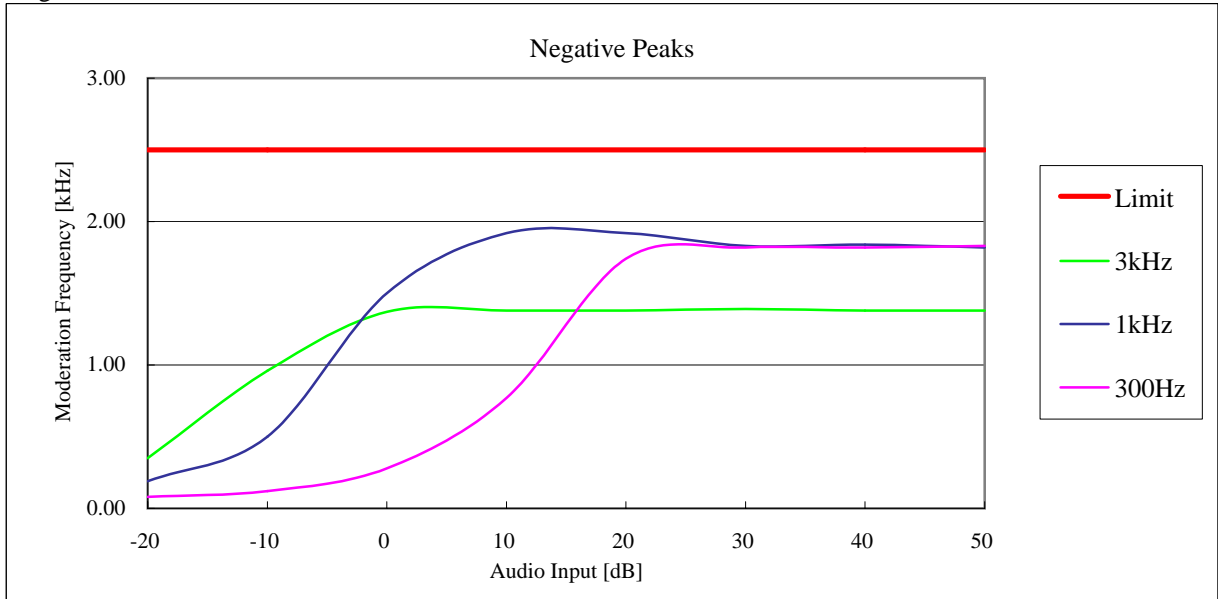

4.8 Frequency Stability (Temperature Variation)

REGULATIONS	: 47 CFR 2.1055 (a) (1), 22.355 , 74.1261 (b) , 90.213(a) RSS-119 Section 7
TEST METHOD/GUIDE	: ANSI/TIA/EIA-603-1992, section 2.2.2.2 / RSS-119 Section 7

TEST PROCEDURE

- 1 The EUT and test equipment were set up as shown on the following page.
- 2 Set the temperature -30 degrees C.
- 3 Leave the EUT for 1 hour after it became the temperature that was set up.
- 4 Make the EUT the transmitting state.
Two minutes later, measure the output frequency.
- 5 Make the EUT the receiving state.
- 6 Set the temperature 50 degrees C by 10 degrees C.
And repeat test procedure 3 to 5.

TEST EQUIPMENTS

No.	Equipment	Manufacture	Model No.	Serial No.	Cal Exp.
1	Spectram Analyzer	Hewlett Packard	E7403A	MY42000062	Jul-05
2	Attenuator (30dB)	Weinschel	53-30-33	KX496	May-06
3	Attenuator (20dB)	Weinschel	40-20-34	AA5701	Jul-05
4	50Ω Termination	TME	CT-01	None	Jul-05
5	DC Power Supply	Kikusui	PAK20-36A	Z0605078	None
6	Temperature Chamber	TABAI	PL-3F	5103661	None
7	Temperature Meter	SATO	PC-5000TRH-II	A14999972	Mar-06
8	Digital Multi Meter	Sanwa	CD721	3040939	Apr-06

MEASUREMENT EQUIPMENT CONFIGURATION

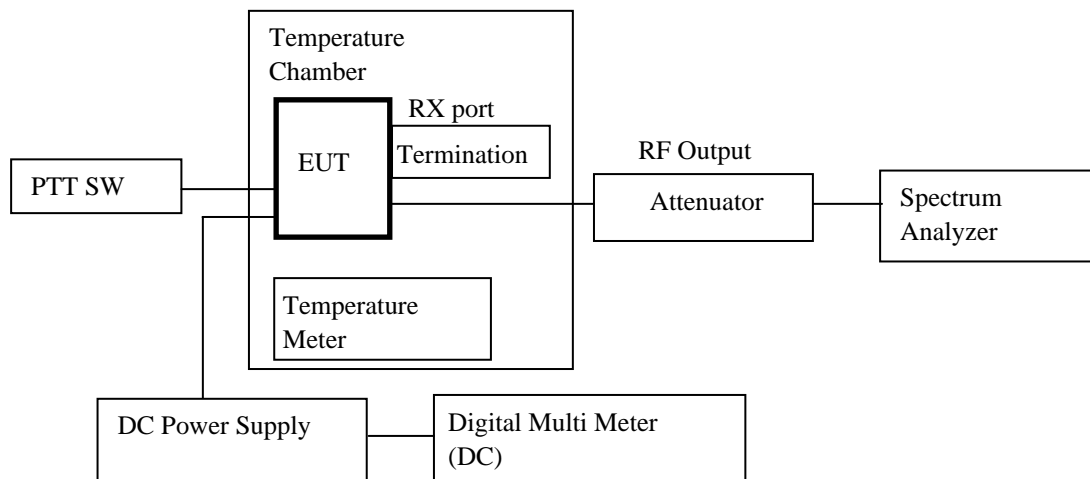

UNCERTAINTY

Measurement uncertainty is +/- 3.6%

TEST RESULTS

Measured for the worst case

State : High Power / Narrow Band Modulation / 430.00 MHz

No.	Temperature (Degree C)	Frequency (MHz)	47 CFR Deviation (ppm)	RSS Deviation (ppm)	Limit (ppm)
1	-30	430.000374	0.87	0.23	1.5
2	-20	430.000415	0.97	0.32	1.5
3	-10	430.000351	0.82	0.17	1.5
4	0	430.000309	0.72	0.08	1.5
5	10	430.000299	0.70	0.05	1.5
6	20	430.000276	0.64	0.00	1.5
7	30	430.000115	0.27	-0.37	1.5
8	40	430.000034	0.08	-0.56	1.5
9	50	429.999988	-0.03	-0.67	1.5

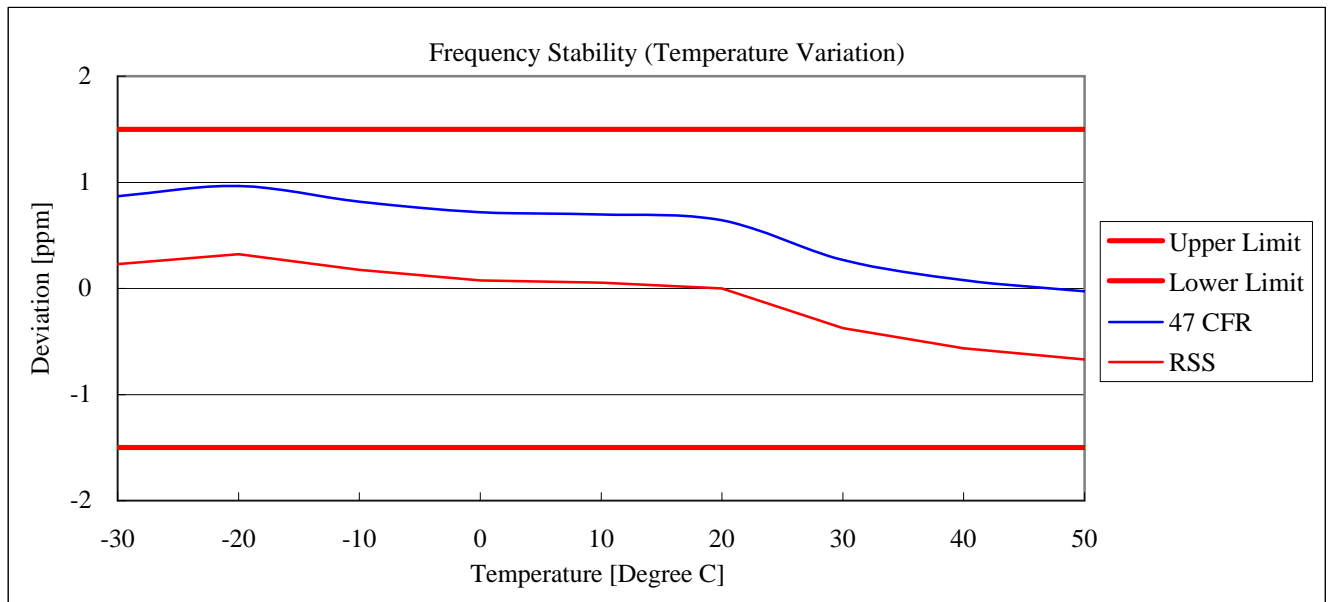

4.9 Frequency Stability (Voltage Variation)

REGULATIONS	: 47 CFR 2.1055 (d) (1), 22.355 , 74.1261 (b) , 90.213(a) RSS-119 Section 7
TEST METHOD/GUIDE	: ANSI/TIA/EIA-603-1992, section 2.2.2.2 / RSS-119 Section 7

TEST PROCEDURE

- 1 The EUT and test equipment were set up as shown on the following page.
- 2 The power supply voltage to the EUT was varied from 85 % to 115 % of the nominal value measured at the input to the EUT.

TEST EQUIPMENTS

No.	Equipment	Manufacture	Model No.	Serial No.	Cal Exp.
1	Spectrum Analyzer	Agilent	E7403A	MY42000062	Jul-05
2	Attenuator (30dB)	Weinschel	53-30-33	KX496	May-06
3	Attenuator (20dB)	Weinschel	40-20-34	AA5701	Jul-05
4	50Ω Termination	TME	CT-01	None	Jul-05
5	DC Power Supply	Kikusui	PAK20-36A	Z0605078	None
6	Digital Multi Meter	Sanwa	CD721	3215593	Apr-06

MEASUREMENT EQUIPMENT CONFIGURATION

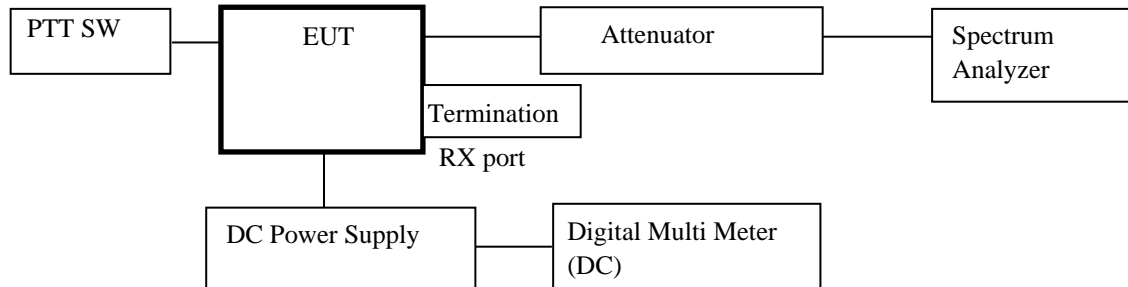

UNCERTAINTY

Measurement uncertainty is +/- 3.6%

TEST RESULTS

Measured for the worst case

State : High Power / Narrow Band Modulation / 430.00 MHz

No.	Diviation (%)	Voltage (V)	Frequency (MHz)	Deviation (ppm)	Limit (ppm)
1	85	11.6	430.000060	0.14	1.5
2	100	13.6	430.000063	0.15	1.5
3	115	15.6	430.000113	0.26	1.5

4.10 Receiver Spurious Emissions(Radiated)

REGULATIONS	: RSS-119, Section 8
TEST METHOD/GUIDE	: RSS-119, Section 8

TEST PROCEDURE

- 1 The EUT and test equipment were set up as shown on the following page.
- 2 Tabletop Equipment
EUT is placed on the wooden table, the top of which is 0.8meter above the metal ground plane(turntable).
- 3 Interconnecting Cables
Excess part of the interconnecting cables longer than 1 meter are bundled in the center.
Cables that hang closer than 40 cm to the ground plane is folded back and forth forming bundle 30 to 40 cm long,
- 4 Measuring Instruments
Measuring instruments list and their calibration schedule are shown on Measurement Equipment Configuration.
The brief description are as follows;
- 5 Antennas
The broadband Bi-cog antenna is used for measurement on the frequency range 30 – 1000 MHz.
The Double ridged guide antenna is used for frequency higher than 1000 MHz
- 6 Pre-amplifier
The broadband pre-amplifier is used for radiated emission measurement.
The signal to noise ratio is improved by using pre-amplifier.
- 7 Spectrum Analyzer
The spectrum analyzer is used for preliminary measurement of frequency range 30 – 1000 MHz, and also used for final measurement of higher than 1000 MHz (Resolution bandwidth : 1 MHz).
- 8 EMI Test Receiver
The Quasi-peak detector (IF bandwidth : 120 kHz) built in test receiver is used for final measurement of the frequency 30 – 1000 MHz.
The test receiver is complied with the specification of the CISPR publication 16.
- 9 Turntable
The turntable is capable for EUT weight and rotatable 0 to 360 degree horizontally by remote control in the test room.
- 10 Antenna Mast
The antenna mast is attachable to all antennas described on antenna height is adjustable 1 to 4 meters continuously by remote control at the test room, and antenna polarization is also changed by the remote control.
Preliminary Measurement
- 11 EUT is tested on all operating conditions.
The spectrum analyzer is set max-hold mode and swept during turntable was rotated 0 to 360 degree. Then spectrum chart are plotted out to find the worst emission conditions in configuration, operating mode, or ambient noise notation.

12 Final Measurement

The EUT operated in the condition where maximum emission is found in the preliminary test.

The turntable azimuth(EUT direction) and antenna height are adjusted the position so that maximum field strength is obtained for each frequency spectrum to be measured.

The equipment and cables are arranged or manipulated within the range of the test standard in the above condition.

When the uncertain result was obtained, the measurement is retried by using the half wave dipole antenna instead of the broadband antenna

TEST EQUIPMENTS

No.	Equipment	Manufacture	Model No.	Serial No.	Cal Exp.
1	Tri-log Antenna	Schwarzbeck	VULB9168	106	Mar-06
2	D.R.G Antenna	Schwarzbeck	BBHA 9120 D	475	Apr-06
3	Step Attenuator	Hewlett Packard	8464B	2726A14513	Oct-05
4	Pre-Amplifier	Hewlett Packard	8447D	1937A03130	Oct-05
5	Pre-Amplifier	TOYO	TPA0118-30	0402	Sep-05
6	Attenuator (6dB)	ANRITSU	MP721B	M57593	Oct-05
7	Attenuator (3dB)	Radiall	R411803121	None	Sep-05
8	Spectrum Analyzer	Agilent	E7403A	MY42000062	Jul-05
9	Test Receiver	Rohde & Schwarz	ESS	847151/012	Jan-06
10	50Ω Termination(1)	TME	CT-01	None	Jul-05
11	50Ω Termination(2)	TME	CT-03NP	None	Aug-05
12	DC Power Supply	Daiwa	PS-3020	None	None
13	Digital Multi Meter	Sanwa	CD721	3040939	Apr-06

MEASUREMENT EQUIPMENT CONFIGURATION

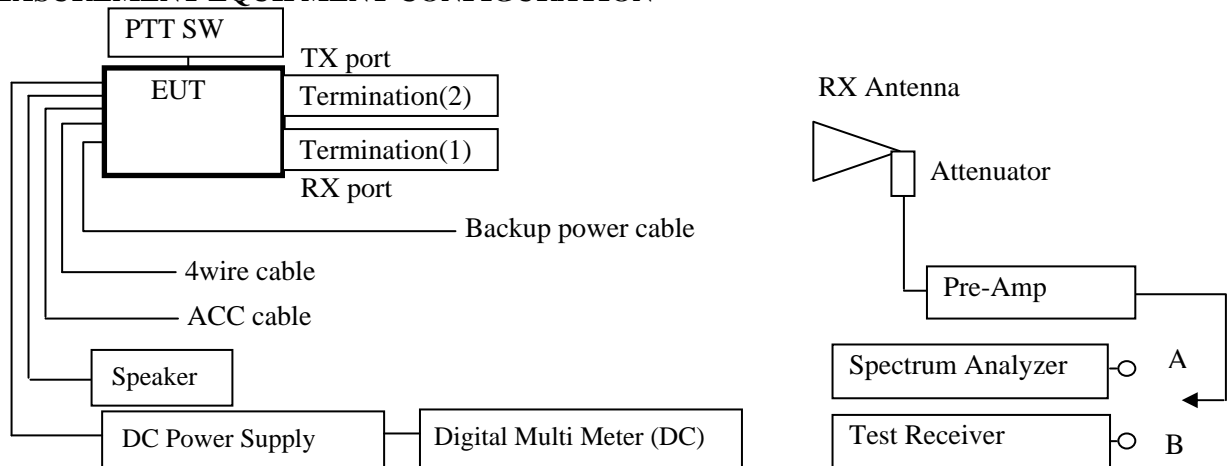

UNCERTAINTY

Measurement uncertainty is +/- 4.6dB (k = 2)

TEST RESULTS

Measured for the worst case

State : 430.00 MHz Receiver Condition

No.	Frequency (MHz)	Pol	Mode	Reading (dBuv)	Factor* (dB/m)	Emission (dBuV/m)	Limit (dBuV/m)	Margin (dB)
1	356.65	Hor.	QP	40.5	-3.1	37.4	46.0	8.6
		Ver.	QP	36.3	-3.1	33.2	46.0	12.8
2	430.06	Hor.	QP	36.5	-1.0	35.5	46.0	10.5
		Ver.	QP	36.7	-1.0	35.7	46.0	10.3
3	713.30	Hor.	QP	21.1	5.3	26.4	46.0	19.6
		Ver.	QP	21.2	5.3	26.5	46.0	19.5
4	860.12	Hor.	QP	22.0	8.9	30.9	46.0	15.1
		Ver.	QP	21.3	8.9	30.2	46.0	15.8
5	1069.95	Hor.	PK	42.2	-3.7	38.5	74.0	35.5
		Hor.	AV	35.1	-3.7	31.4	54.0	22.6
		Ver.	PK	40.4	-3.7	36.7	74.0	37.3
		Ver.	AV	35.8	-3.7	32.1	54.0	21.9
6	1426.60	Hor.	PK	48.6	-2.6	46.0	74.0	28.0
		Hor.	AV	45.5	-2.6	42.9	54.0	11.1
		Ver.	PK	53.9	-2.6	51.3	74.0	22.7
		Ver.	AV	51.5	-2.6	48.9	54.0	5.1
7	1783.25	Hor.	PK	42.3	-2.6	39.7	74.0	34.3
		Hor.	AV	34.6	-2.6	32.0	54.0	22.0
		Ver.	PK	42.8	-2.6	40.2	74.0	33.8
		Ver.	AV	38.2	-2.6	35.6	54.0	18.4
8	2580.36	Hor.	PK	40.7	0.1	40.8	74.0	33.2
		Hor.	AV	31.2	0.1	31.3	54.0	22.7
		Ver.	PK	39.0	0.1	39.1	74.0	34.9
		Ver.	AV	29.4	0.1	29.5	54.0	24.5
9	3010.40	Hor.	PK	38.6	1.0	39.6	74.0	34.4
		Hor.	AV	30.5	1.0	31.5	54.0	22.5
		Ver.	PK	40.4	1.0	41.4	74.0	32.6
		Ver.	AV	32.5	1.0	33.5	54.0	20.5
10	3870.52	Hor.	PK	41.6	2.2	43.8	74.0	30.2
		Hor.	AV	33.7	2.2	35.9	54.0	18.1
		Ver.	PK	42.3	2.2	44.5	74.0	29.5
		Ver.	AV	37.0	2.2	39.2	54.0	14.8

There is the margin of 20dB over except for the above points.

* Factor = Antenna, Antenna Pad, Cable, Preamp

Emission Level = Reading Level + Factor

Note:

- 1 Measurement distance is 3 metres.
- 2 Scanned frequency are 30 to 5000 MHz.
- 3 Maximum local oscillator frequency is 430.00MHz.
- 4 The EUT which was connected to an ACC cable was measured because the equipment which is connected to an ACC port for the digital forwarding did not exist.
- 5 The EUT which was connected to an 4-wire cable was measured because the equipment which is connected to an 4-wire port for the digital forwarding did not exist.

5. VALIDITY OF TEST REPORT

The test result of this report is effective for equipment under test itself and under the test configuration described on the report.

This test report does not assure that whether the test result taken in other testing laboratory is compatible or reproducible to the test result on this report or not.

Copying of this report without permission is prohibited.

6. DESCRIPTION OF TEST LABORATORY

ACCREDITATION		SCOPE	LAB. CODE
NVLAP	USA	EMC Testing	100290-0
NVLAP	USA	Calibration	100290-0
NVLAP	USA	Telecommunication	100290-0
VLAC	JAPAN	EMC Testing	VLAC-008
BSMI	TAIWAN	EMC Testing	SL2-IN-E-6008
NATA	AUSTRALIA	Calibration	13491
NATA	AUSTRALIA	Telecommunication	100290-0

AUTHORIZATION		SCOPE	LAB. CODE
NEMKO	NORWAY	EMC Testing	ELA107
ETL SEMKO JAPAN	SWEDEN	EMC Testing	9200202558R

FILING		SCOPE	LAB. CODE
FCC	USA	EMC Testing	934283
IC	CANADA	EMC Testing	IC-2065
IC	CANADA	Telecommunication	IC-2065
VCCI	JAPAN	EMC Testing	

Note 1 : NVLAP accreditation does not constitute any product endorsement by NVLAP or any agent of the U.S. Government.